

**GUMMIMETALLTEILE  
RUBBER - METAL - PARTS  
PIÈCES MÉTALLO - CAOUTCHOUC  
CZĘŚCI METALOWO - GUMOWE**



**OPTIMAL®**







### Radlagersätze

Wheel Bearing Kits  
Kits de Roulements de Roues  
Zestawy łożyskowe do kół

Art. Nr. **WBM-3000**



### Lenkungsteile

Steering and Suspension Parts  
Pièces de Direction et Suspension  
Elementy zawieszenia

Art. Nr. **WBM-3001A** European Cars  
Art. Nr. **WBM-3001B** Asian Cars



### Stoßdämpfer

Shock Absorbers  
Amortisseurs  
Amortyzatory

Art. Nr. **WBM-3002**



### Bremssysteme

Brake Systems  
Systèmes de Freinage  
Systemy hamulcowe

Art. Nr. **WBM-3003**



### Gummimetallteile

Rubber Metal Parts  
Pièces Caoutchouc-Métal  
Części metalowo-gumowe

Art. Nr. **WBM-3004**



### Spannrollensätze

Belt Tensioner Kits  
Kits de Distribution  
Zestawy paska rozrządu

Art. Nr. **WBM-3005**



### Wasserpumpen

Waterpumps  
Pompes à Eau  
Pompy wodne

Art. Nr. **WBM-3006**



### Gasfedern

Gas Springs  
Vérins à Gaz  
Sprężyny gazowe

Art. Nr. **WBM-3007**



### Sensoren Raddrehzahl

Sensors wheel speed  
Capteurs vitesse de roue  
Czujniki liczba obrotów koła

Art. Nr. **WBM-3008**

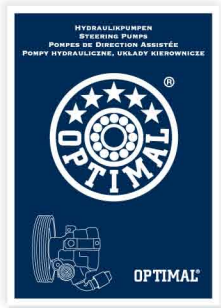

### Hydraulikpumpen

Steering Pumps  
Pompes de Direction Assistée  
Pompy hydrauliczne

Art. Nr. **WBM-3010**



### Fahrwerksfedern

Coil Springs  
Ressorts de Suspension  
Sprężyny zawieszenia

Art. Nr. **WBM-3011** Premium Line  
Art. Nr. **WBM-3011S** Standard Line

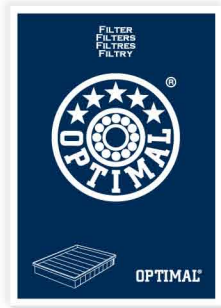

### Filter

Filters  
Filtres  
Filtry

Art. Nr. **WBM-3012**



### Ersatzteile für Kleintransporter

Parts for Light Commercial Vehicles  
Pièces de Recharge Véhicules  
Utilitaires Légers  
Części do samochodów dostawczych

Art. Nr. **WBM-3013**



### Bremsbackensätze

Brake Shoe Kits  
Jeu de Mâchoires de Frein  
Zestawy szczęk hamulcowych

Art. Nr. **WBM-3014**



### Ersatzteile für Elektro- und Hybridfahrzeuge

Parts for electric- and hybrid vehicles  
Pièce de rechange pour véhicules  
électrique et hybride

Art. Nr. **WBM-3015**



### Sensoren Motorsteuerung

Engine control sensors  
Capteurs pour commande moteur  
Czujniki układu sterowania silnika

Art. Nr. **WBM-3016**



Steering and Suspension Parts



Lenkungsteile





## I. Car Manufacturers:

ABARTH.....	1 - 1
ALFA ROMEO.....	2 - 11
AUDI.....	12 - 130
AUSTIN.....	131 - 131
AUTOBIANCHI.....	132 - 132
BMW.....	133 - 192
CHEVROLET.....	193 - 196
CHRYSLER.....	197 - 198
CITROËN.....	199 - 257
DACIA.....	258 - 261
DAEWOO.....	262 - 266
DAIHATSU.....	267 - 267
DODGE.....	268 - 268
FIAT.....	269 - 314
FORD.....	315 - 374
HONDA.....	375 - 382
HYUNDAI.....	383 - 390
JAGUAR.....	391 - 391
JEEP.....	392 - 392
KIA.....	393 - 397
LADA.....	398 - 398
LANCIA.....	399 - 407
LAND ROVER.....	408 - 408
MAZDA.....	409 - 415
MERCEDES-BENZ.....	416 - 497
MG.....	498 - 498
MINI.....	499 - 502
MITSUBISHI.....	503 - 508
NISSAN.....	509 - 520
OPEL.....	521 - 602
PEUGEOT.....	603 - 678
PORSCHE.....	679 - 681
RENAULT.....	682 - 755
ROVER.....	756 - 758
SAAB.....	759 - 764
SEAT.....	765 - 811
SKODA.....	812 - 849
SMART.....	850 - 852
SUBARU.....	853 - 854
SUZUKI.....	855 - 858
TALBOT.....	859 - 859
TOYOTA.....	860 - 875
VAUXHALL.....	876 - 931
VOLVO.....	932 - 960
VW.....	961 - 1129



## II. Comparison lists

ORIGINAL-NO. / OPTIMAL NO.....	A-1 - A-44
REFERENCE-NO./ OPTIMAL NO.....	B-1 - B-29

Dieser Katalog wurde mit großer Sorgfalt zusammengestellt.  
Dennoch kann für die darin gemachten Angaben und Hinweise keine Gewähr übernommen werden.  
Herstellernamen und -nummern sind nur zu Informationszwecken aufgeführt.

All data in the catalogue have been carefully checked.  
No liability, however, can be accepted for any errors.  
Original replacement numbers are for comparison reasons only.



	D	GB
	Vorderachse	Front Axle
	Hinterachse	Rear Axle
	Links	Left
	Rechts	Right
	Oben	Upper
	Unten	Lower
	Für Fahrzeuge mit Servolenkung	For vehicles with power steering
	Für Fahrzeuge ohne Servolenkung	For vehicles without power steering
	Für Fahrzeuge mit Klimaanlage	For vehicles with air conditioning
	Für Fahrzeuge ohne Klimaanlage	For vehicles without air conditioning
	Für Fahrzeuge mit ABS	For vehicles with ABS
	Für Fahrzeuge ohne ABS	For vehicles without ABS
	Für Fahrzeuge mit EDC	For vehicles with EDC
	Für Fahrzeuge ohne EDC	For vehicles without EDC
	Für Fahrzeuge mit Standard Fahrwerk	For vehicles with standard chassis
	Für Fahrzeuge mit Sportfahrwerk	For vehicles with sports suspension
	Für Fahrzeuge ohne Sportfahrwerk	For vehicles without sports suspension
	Für Fahrzeuge mit M-Technik	For vehicles with M-technics
	Für Fahrzeuge ohne M-Technik	For vehicles without M-technics
	Für Fahrzeuge mit verstärktem Fahrwerk	For vehicles with heavy duty suspension
	Für Fahrzeuge ohne verstärktes Fahrwerk	For vehicles without heavy duty suspension
	Für Fahrzeuge mit Schlechtwegeausführung	For vehicles with off-road suspension
	Für Fahrzeuge ohne Schlechtwegeausführung	For vehicles without off-road suspension
	Für Fahrzeuge mit Komfortfahrwerk	For vehicles with comfort suspension
	Für Fahrzeuge mit Luftfederung	For pneumatic suspension vehicles
	Für Fahrzeuge ohne Luftfederung	For vehicles without pneumatic suspension
	Für Fahrzeuge mit verstärkten Stoßdämpfern	For vehicles with reinforced shock absorbers
	Für Fahrzeuge mit Schlechtwegeausführung	For vehicles with increased spring tension
	Für Fahrzeuge ohne Schlechtwegeausführung	For vehicles without increased spring tension
	Für Fahrzeuge mit elektr. Dämpferregulierung	For vehicles with electronic suspension control
	Für Fahrzeuge ohne elektr. Dämpferregulierung	For vehicles without electronic suspension control
	Für Fahrzeuge mit erhöhter Bodenfreiheit	For vehicles with increased ground clearance
	Für Fahrzeuge mit tiefergelegtem Fahrwerk	For vehicles with lowered chassis
	Für Fahrzeuge ohne tiefergelegtes Fahrwerk	For vehicles without lowered chassis
	Für Fahrzeuge mit Niveauregulierung	For vehicles with ride height control
	Für Fahrzeuge ohne Niveauregulierung	For vehicles without ride height control
	Blattfederachse	Leaf spring axle
	Nutzlast	Payload
	für Fahrzeuge mit erhöhter Achslast	For vehicles with increased axle load
	Radstand [mm]	Wheelbase [mm]
	Für verkürzten Radstand	For shortened wheelbase
	Für verlängerten Radstand	For extended wheelbase
	Nicht für verlängerten Radstand	Not for extended wheelbase





D	GB
Einzelradaufhängung	Independent wheel suspension
Starrachse	Rigid axle
Für Fahrzeuge mit Stabilisator	For vehicles with stabiliser
Für Fahrzeuge ohne Stabilisator	For vehicles without stabilizer
Achsausführung	Axle Version
Für Fahrzeuge mit Einfachkabine	For vehicles with single cab
Für Fahrzeuge mit Doppelkabine	For vehicles with double-cab
Für Mietwagen	For rental vehicles
Für Taxifahrzeuge	For taxis
Nicht für Taxifahrzeuge	Not for taxis
Für gepanzerte Fahrzeuge	For armoured vehicles
Nicht für gepanzerte Fahrzeuge	Not for armoured vehicles
Schaltgetriebe	Manual Transmission
Automatikgetriebe	Automatic Transmission
Motorcode	Engine Code
Für Fahrzeuge mit Erdgasantrieb	For vehicles with a natural gas engine
Frontantrieb	Front Wheel Drive
Heckantrieb	Rear Wheel Drive
Allrad	All-wheel Drive
für Linkslenker	For Left-hand drive vehicles
für Rechtslenker	For right-hand drive vehicles
Türenanzahl 3	Number of Doors 3
Türenanzahl 4	Number of Doors 4
Türenanzahl 5	Number of Doors 5
Felge Lochzahl	Rim Hole Number
Anzahl der Zahnzacken	Numbers of teeth
Felgengröße	Rim Size
Mit Lager	With bearing(s)
Ohne Lager	Without bearing(s)
Mit Kugellager	With ball bearing
Ohne Kugellager	Without ball bearing
Mit Wälzlager	With anti-friction bearing
Ohne Wälzlager	Without anti-friction bearing
Mit Staubschutz	With dust cover
Fahrzeugproduktionsland Afrika	Vehicle Production Country Africa
Fahrzeugproduktionsland Südafrika	Vehicle Production Country South Africa
Fahrzeugproduktionsland Brasilien	Vehicle Production Country Brazil
Fahrzeugproduktionsland Japan	Vehicle Production Country Japan
Fahrzeugproduktionsland Rumänien	Vehicle Production Country Romania
Fahrzeugproduktionsland Großbritannien	Vehicle Production Country Great Britain
Länderausführung Afrika	Country Version Africa
Länderausführung Argentinien	Country Version Argentina
Länderausführung Australien	Country Version Australia



<del>AU</del>	Nicht für Länderausführung Australien	Not for country-spec. Model Australia
BE	Länderausführung Belgien	Country Version Belgium
CN	Länderausführung China	Country Version China
DE	Länderausführung Deutschland	Country Version Germany
ES	Länderausführung Spanien	Country Version Spain
<del>FR</del>	Nicht für Länderausführung Frankreich	Not for country-spec. Model France
IN	Länderausführung Indien	Country Version India
<del>IN</del>	Nicht für Länderausführung Indien	Not for country-spec. Model India
JP	Länderausführung Japan	Country Version Japan
<del>JP</del>	Nicht für Länderausführung Japan	Not for country-spec. Model Japan
ME	Länderausführung Nahen Osten	Country Version Middle East
<del>NZ</del>	Nicht für Länderausführung Neuseeland	Not for country-spec. Model New Zealand
RU	Länderausführung Russland	Country Version Russia
<del>SA</del>	Nicht für Länderausführung Saudi-Arabien	Not for country-spec. Model Saudi Arabia
TR	Länderausführung Türkei	Country Version Turkey
UE	Länderausführung Europa	Country Version Europe
USA	Länderausführung USA	Country Version USA
ZA	Länderausführung Südafrika	Country Version South Africa
<del>ZA</del>	Nicht für Länderausführung Südafrika	Not for country-spec. Model South Africa

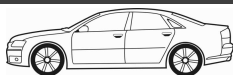

**Article Description****Article Nr.****Fitting Position**

<b>500 (312)</b>				<b>08/2008 →</b>	
Rubber Buffer, suspension	1.4 Abarth		<b>F8-7594</b>		H=228
<b>500 (312)</b>				<b>08/2008 →</b>	
Spring Cap	1.4 Abarth		<b>F8-6560</b>		
Rubber Buffer, suspension	1.4 Abarth		<b>F8-7484</b>		
<b>500C (312)</b>				<b>09/2009 →</b>	
Rubber Buffer, suspension	1.4 Abarth		<b>F8-7484</b>		
Rubber Buffer, suspension	1.4 Abarth		<b>F8-7594</b>		H=228
<b>GRANDE PUNTO (199)</b>				<b>12/2007 → 12/2012</b>	
Top Strut Mounting	All Models		<b>F8-7421</b>		
Spring Cap	All Models		<b>F8-7422</b>		
Top Strut Mounting	All Models		<b>F8-7423</b>		
Top Strut Mounting	All Models		<b>F8-7424</b>		
Protective Cap/Bellow, shock absorber	All Models		<b>F8-7663</b>		H=205
Control Arm-/Trailing Arm Bush	All Models		<b>F8-7995</b>		
<b>PUNTO (199)</b>				<b>07/2008 →</b>	
Protective Cap/Bellow, shock absorber	All Models		<b>F8-7663</b>		H=205
Control Arm-/Trailing Arm Bush	1.4 Abarth		<b>F8-7995</b>		
<b>STRADA (138A)</b>				<b>11/1981 → 12/1987</b>	
Anti-Friction Bearing	All Models		<b>F8-3017</b>		d=50; D=70
Top Strut Mounting	All Models		<b>F8-5927</b>		

<b>F8-3017</b>	<b>F8-5927</b>	<b>F8-6560</b>	<b>F8-7421</b>	<b>F8-7422</b>	<b>F8-7423</b>	<b>F8-7424</b>
Ref.Nr.: 4400895	Ref.Nr.: 7537167	Ref.Nr.: 46541086	Ref.Nr.: 51813225	Ref.Nr.: 344963	Ref.Nr.: 55701902	Ref.Nr.: 55703318
<b>F8-7484</b>	<b>F8-7594</b>	<b>F8-7663</b>				
Ref.Nr.: 51811829	Ref.Nr.: 1 639 562	Ref.Nr.: 344435				
			<b>F8-7995</b>			
			Ref.Nr.: 55700751			

Article Description				Article Nr.	Fitting Position	
<b>4C (960, 960_)</b>				<b>03/2013 →</b>		
Alternator Freewheel Clutch	All Models			<b>F5-1147</b>		
<b>6 (119)</b>				<b>04/1979 → 12/1986</b>		
Bellow, steering	All Models	with clamps;		<b>LM-10037S</b>		d1=12; d2=47; L [mm]=180
<b>33 (905)</b>				<b>05/1983 → 12/1993</b>		
Dust Cover Kit, shock absorber	All Models			<b>AK-735004</b>	⊕ ⊕	
Anti-Friction Bearing	1.2, 1.3, 1.5, 1.5 QV, 1.7 i.e.			<b>F8-3062</b>		H=14; d=62; D=90
Top Strut Mounting	1.2, 1.3, 1.3 i.e., 1.5, 1.5 4x4, 1.5 QV, 1.7, 1.7 i.e., 1.7 QV			<b>F8-5604</b>	⊕ ⊕	
<b>33 Sportwagon (905A)</b>				<b>01/1984 → 12/1989</b>		
Dust Cover Kit, shock absorber	All Models			<b>AK-735004</b>	⊕ ⊕	
Anti-Friction Bearing	1.5, 1.7			<b>F8-3062</b>		H=14; d=62; D=90
Top Strut Mounting	1.5, 1.5 4x4, 1.7, 1.7 i.e., 1.7 i.e. 4x4			<b>F8-5604</b>	⊕ ⊕	
<b>33 (907A)</b>				<b>01/1990 → 09/1994</b>		
Dust Cover Kit, shock absorber	1.4 i.e., 1.5, 1.5 i.e., 1.5 i.e., 1.7 16V, 1.7 16V 4x4, 1.7 i.e., 1.7 i.e. 4x4, 1.8 TD			<b>AK-735004</b>	⊕ ⊕	
Anti-Friction Bearing	1.4 i.e., 1.7 16V, 1.7 i.e.			<b>F8-3062</b>		H=14; d=62; D=90
Top Strut Mounting	1.4 4x4, 1.5			<b>F8-5604</b>	⊕ ⊕	
Top Strut Mounting	1.4 i.e., 1.5 i.e., 1.5 i.e., 1.7 16V, 1.7 16V 4x4, 1.7 i.e., 1.7 i.e. 4x4, 1.8 TD	ch.→5455777;		<b>F8-5604</b>	⊕ ⊕	
<b>33 Sportwagon (907B)</b>				<b>01/1990 → 09/1994</b>		
Dust Cover Kit, shock absorber	1.4 i.e., 1.4 i.e. 4x4, 1.5 i.e., 1.7 16V, 1.7 16V 4x4, 1.7 i.e., 1.7 i.e. 4x4			<b>AK-735004</b>	⊕ ⊕	
Anti-Friction Bearing	1.5 i.e.			<b>F8-3062</b>		H=14; d=62; D=90
Top Strut Mounting	1.4 i.e., 1.4 i.e. 4x4, 1.5 i.e., 1.7 16V, 1.7 16V 4x4, 1.7 i.e., 1.7 i.e. 4x4	ch.→5455777;		<b>F8-5604</b>	⊕ ⊕	
<b>75 (162B)</b>				<b>05/1985 → 12/1992</b>		
Control Arm-/Trailing Arm Bush	1.6, 1.8, 1.8 Turbo, 1.8 Turbo i.e., 2.0 T.S., 2.0 T.S., 2.0 TD, 2.4 TD, 2.5 V6, 2.5 V6 CAT, 3.0 V6	for OE: 60521240		<b>F8-6456</b>	⊕ ⊕	d=17; D=38
Control Arm-/Trailing Arm Bush	1.8			<b>F8-6456</b>	⊕ ⊕	d=17; D=38
Control Arm-/Trailing Arm Bush	2.0	for OE: 9943856		<b>F8-6456</b>	⊕ ⊕	d=17; D=38
Bellow, steering	1.6, 1.8, 1.8 Turbo, 1.8 Turbo i.e., 2.0, 2.0 T.S., 2.0 T.S., 2.0 TD, 2.5 V6 CAT, 3.0 V6	with clamps;		<b>LM-10037S</b>		d1=12; d2=47; L [mm]=180
Bellow, steering	2.0 T.S., 3.0 V6	04/1987 →; with clamps;		<b>LM-10037S</b>		d1=12; d2=47; L [mm]=180
Bellow, steering	2.4 TD	05/1989 →; with clamps;		<b>LM-10037S</b>		d1=12; d2=47; L [mm]=180

<b>AK-735004</b>	<b>F5-1147</b>	<b>F8-3062</b>	<b>F8-5604</b>	<b>F8-6456</b>	<b>LM-10037S</b>
Ref.Nr.:	Ref.Nr.: 77365271	Ref.Nr.: 60501446	Ref.Nr.: 40504729	Ref.Nr.: 60521240	Ref.Nr.: 60724154



**Article Description****Article Nr.****Fitting Position**

<b>90 (162)</b>			<b>10/1984 → 07/1987</b>		
Control Arm-/Trailing Arm Bush	All Models	for OE: 60521240	<b>F8-6456</b>		d=17; D=38
Bellow, steering	1.8	07/1985 →; with clamps;	<b>LM-10037S</b>		d1=12; d2=47; L [mm]=180
Bellow, steering	1.8, 2.0 i.e., 2.4 TD, 2.5 i.e. V6	with clamps;	<b>LM-10037S</b>		d1=12; d2=47; L [mm]=180
Bellow, steering	2.5 i.e. V6	with clamps;	<b>LM-10037S</b>		d1=12; d2=47; L [mm]=180
<b>145 (930)</b>			<b>07/1994 → 01/2001</b>		
Dust Cover Kit, shock absorber	1.4 i.e., 1.4 i.e. 16V T.S., 1.6 i.e., 1.6 i.e. 16V T.S., 1.7 i.e. 16V, 1.8 i.e. 16V, 1.8 i.e. 16V T.S., 1.9 JTD, 1.9 TD, 2.0 16V Quadrifoglio, 2.0 16V T.S.		<b>AK-735088</b>		
Dust Cover Kit, shock absorber	1.4 i.e., 1.4 i.e. 16V T.S., 1.6 i.e., 1.6 i.e. 16V T.S., 1.7 i.e. 16V, 1.8 i.e. 16V, 1.8 i.e. 16V T.S., 1.9 JTD, 1.9 TD, 2.0 16V Quadrifoglio, 2.0 16V T.S.		<b>AK-735337</b>		
Alternator Freewheel Clutch	1.4 i.e., 1.9 JTD		<b>F5-1123</b>		
Anti-Friction Bearing	1.4 i.e., 1.4 i.e. 16V T.S., 1.6 i.e., 1.6 i.e. 16V T.S., 1.7 i.e. 16V, 1.8 i.e. 16V T.S., 1.9 TD, 2.0 16V T.S.		<b>F8-3015</b>		H=48; d1=79; d2=84; D1=116; D2=128
Top Strut Mounting	1.4 i.e., 1.4 i.e. 16V T.S., 1.6 i.e., 1.6 i.e. 16V T.S., 1.7 i.e. 16V, 1.8 i.e. 16V, 1.8 i.e. 16V T.S., 1.9 JTD, 1.9 TD, 2.0 16V Quadrifoglio, 2.0 16V T.S.		<b>F8-5605</b>		
Top Strut Mounting	1.4 i.e., 1.4 i.e. 16V T.S., 1.6 i.e., 1.6 i.e. 16V T.S., 1.7 i.e. 16V, 1.8 i.e. 16V, 1.8 i.e. 16V T.S., 1.9 JTD, 1.9 TD, 2.0 16V Quadrifoglio, 2.0 16V T.S.		<b>F8-5606</b>		
Spring Cap	1.4 i.e., 1.4 i.e. 16V T.S., 1.6 i.e., 1.6 i.e. 16V T.S., 1.7 i.e. 16V, 1.8 i.e. 16V, 1.8 i.e. 16V T.S., 1.9 JTD, 1.9 TD, 2.0 16V Quadrifoglio, 2.0 16V T.S.		<b>F8-5956</b>		
Belt Pulley, crankshaft	1.9 JTD	Number of Ribs: 5; Parameter: 6PK; with screw set	<b>F8-6393</b>		D=169
Engine Mounting	1.4 i.e. 16V T.S.	AR33503	<b>F8-6631</b>		
Engine Mounting	1.6 i.e. 16V T.S.	AR67601	<b>F8-6631</b>		
Engine Mounting	1.8 i.e. 16V T.S.	AR67106	<b>F8-6631</b>		
Engine Mounting	1.8 i.e. 16V, 2.0 16V Quadrifoglio, 2.0 16V T.S.		<b>F8-6631</b>		
Engine Mounting	1.4 i.e. 16V T.S.		<b>F8-6632</b>		
Belt Pulley, crankshaft	1.9 TD		<b>F8-7863</b>		
Control Arm-/Trailing Arm Bush	1.4 i.e., 1.4 i.e. 16V T.S., 1.6 i.e., 1.6 i.e. 16V T.S., 1.7 i.e. 16V, 1.8 i.e. 16V, 1.8 i.e. 16V T.S., 1.9 JTD, 1.9 TD, 2.0 16V Quadrifoglio, 2.0 16V T.S.		<b>G9-530</b>		H=50; d=20; D=41
<b>146 (930)</b>			<b>12/1994 → 01/2001</b>		
Dust Cover Kit, shock absorber	1.4 i.e., 1.4 i.e. 16V T.S., 1.6 i.e., 1.6 i.e. 16V T.S., 1.7 i.e. 16V, 1.8 i.e. 16V T.S., 1.9 JTD, 1.9 TD, 2.0 16V Quadrifoglio, 2.0 16V T.S.		<b>AK-735088</b>		
Dust Cover Kit, shock absorber	1.4 i.e., 1.4 i.e. 16V T.S., 1.6 i.e., 1.6 i.e. 16V T.S., 1.7 i.e. 16V, 1.8 i.e. 16V T.S., 1.9 JTD, 1.9 TD, 2.0 16V Quadrifoglio, 2.0 16V T.S.		<b>AK-735337</b>		

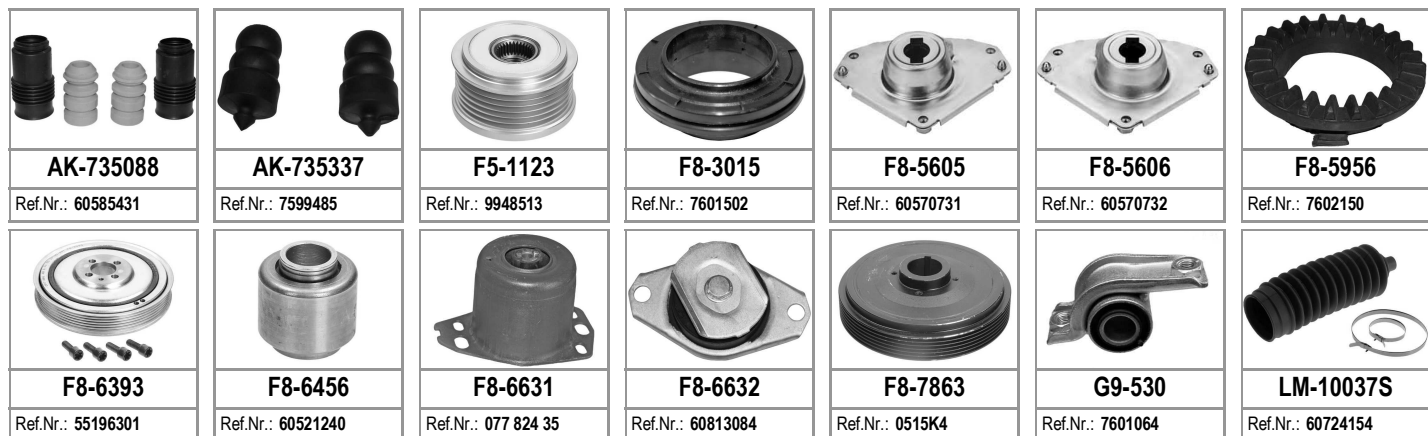

Article Description



Article Nr.

Fitting Position



146 (930)		12/1994 → 01/2001	
Alternator Freewheel Clutch	1.9 JTD		F5-1123
Anti-Friction Bearing	1.4 i.e., 1.4 i.e. 16V T.S., 1.6 i.e., 1.6 i.e. 16V T.S., 1.7 i.e. 16V, 1.8 i.e. 16V T.S., 1.9 TD, 2.0 16V T.S.		F8-3015
Top Strut Mounting	1.4 i.e. 16V T.S., 1.6 i.e. 16V T.S., 1.8 i.e. 16V T.S., 1.9 JTD, 1.9 TD, 2.0 16V Quadrifoglio		F8-5605
Top Strut Mounting	1.4 i.e., 1.6 i.e., 1.7 i.e. 16V	05/1995 →;	F8-5605
Top Strut Mounting	2.0 16V T.S.	02/1996 →;	F8-5605
Top Strut Mounting	1.4 i.e. 16V T.S., 1.6 i.e. 16V T.S., 1.8 i.e. 16V T.S., 1.9 JTD, 1.9 TD, 2.0 16V Quadrifoglio		F8-5606
Top Strut Mounting	1.4 i.e., 1.6 i.e., 1.7 i.e. 16V	05/1995 →;	F8-5606
Top Strut Mounting	2.0 16V T.S.	02/1996 →;	F8-5606
Spring Cap	1.4 i.e., 1.4 i.e. 16V T.S., 1.6 i.e., 1.6 i.e. 16V T.S., 1.7 i.e. 16V, 1.8 i.e. 16V T.S., 1.9 JTD, 1.9 TD, 2.0 16V Quadrifoglio, 2.0 16V T.S.		F8-5956
Belt Pulley, crankshaft	1.9 JTD	Number of Ribs: 5; Parameter: 6PK; with screw set	F8-6393
Engine Mounting	1.4 i.e. 16V T.S.	AR33503	F8-6631
Engine Mounting	1.6 i.e. 16V T.S.	AR67601	F8-6631
Engine Mounting	1.8 i.e. 16V T.S.	AR67106	F8-6631
Engine Mounting	1.8 i.e. 16V T.S., 2.0 16V Quadrifoglio, 2.0 16V T.S.		F8-6631
Engine Mounting	1.4 i.e. 16V T.S.		F8-6632
Belt Pulley, crankshaft	1.9 TD		F8-7863
Control Arm-/Trailing Arm Bush	1.4 i.e., 1.4 i.e. 16V T.S., 1.6 i.e., 1.6 i.e. 16V T.S., 1.7 i.e. 16V, 1.8 i.e. 16V T.S., 1.9 JTD, 1.9 TD, 2.0 16V Quadrifoglio, 2.0 16V T.S.		G9-530
147 (937)		01/2001 → 03/2010	
Dust Cover Kit, shock absorber	1.6 16V T.SPARK , 1.6 16V T.SPARK ECO , 1.9 JTD, 1.9 JTD 16V, 1.9 JTDM 16V, 1.9 JTDM 8V, 2.0 16V T.SPARK		AK-735066
Alternator Freewheel Clutch	1.9 JTD , 1.9 JTD 16V, 1.9 JTDM, 1.9 JTDM 16V, 1.9 JTDM 8V		F5-1123
Top Strut Mounting	1.6 16V T.SPARK , 1.6 16V T.SPARK ECO , 1.9 JTD, 1.9 JTD 16V, 1.9 JTDM, 1.9 JTDM 16V, 1.9 JTDM 8V, 2.0, 2.0 16V T.SPARK , 3.2 GTA		F8-6289
Belt Pulley, crankshaft	1.9 JTD 16V	Number of Ribs: 5; Parameter: 6PK; with screw set	F8-6393
Engine Mounting	2.0, 2.0 16V T.SPARK		F8-6631
Engine Mounting	3.2 GTA		F8-6914
Top Strut Mounting	1.6 16V T.SPARK , 1.6 16V T.SPARK ECO , 1.9 JTD, 1.9 JTD 16V, 1.9 JTDM, 1.9 JTDM 16V, 1.9 JTDM 8V, 2.0, 2.0 16V T.SPARK , 3.2 GTA		F8-7418

AK-735066	F5-1123	F8-3015	F8-5605	F8-5606	F8-5956	F8-6289
Ref.Nr.: 60650551	Ref.Nr.: 9948513	Ref.Nr.: 7601502	Ref.Nr.: 60570731	Ref.Nr.: 60570732	Ref.Nr.: 7602150	Ref.Nr.: 60625002
F8-6393	F8-6631	F8-6632	F8-6914	F8-7418	F8-7863	G9-530
Ref.Nr.: 55196301	Ref.Nr.: 077 824 35	Ref.Nr.: 60813084	Ref.Nr.: 60805971	Ref.Nr.: 46791956	Ref.Nr.: 0515K4	Ref.Nr.: 7601064
LM-10038S						
Ref.Nr.: 9947921						

**Article Description****Article Nr.****Fitting Position**

<b>147 (937)</b>				<b>01/2001 → 03/2010</b>	
Bellow, steering	1.6 16V T.SPARK , 1.6 16V T.SPARK ECO , 2.0 16V T.SPARK	ch.→3432087; with clamps	<b>LM-10038S</b>		d1=12; d2=61; L [mm]=210
Bellow, steering	1.9 JTD , 1.9 JTDM 8V, 2.0, 3.2 GTA	with clamps	<b>LM-10038S</b>		d1=12; d2=61; L [mm]=210
Bellow, steering	1.9 JTD 16V	ch.→3383829; with clamps	<b>LM-10038S</b>		d1=12; d2=61; L [mm]=210
<b>155 (167)</b>				<b>01/1992 → 12/1997</b>	
Dust Cover Kit, shock absorber	All Models		<b>AK-735088</b>		
Dust Cover Kit, shock absorber	All Models		<b>AK-735337</b>		
Anti-Friction Bearing	1.6 16V T.S. , 1.7 T.S. , 1.7 T.S. 16V, 1.8 T.S. , 1.8 T.S. Sport , 1.9 TD , 2.0 16V Turbo Q4 , 2.0 T.S. , 2.0 T.S. 16V , 2.5 TD , 2.5 V6		<b>F8-3015</b>		H=48; d1=79; d2=84; D1=116; D2=128
Top Strut Mounting	All Models		<b>F8-5605</b>		
Top Strut Mounting	All Models		<b>F8-5606</b>		
Spring Cap	All Models		<b>F8-5956</b>		
Engine Mounting	1.6 16V T.S. , 1.7 T.S. 16V, 2.0 16V Turbo Q4, 2.0 T.S. 16V		<b>F8-6631</b>		
Engine Mounting	1.7 T.S. , 1.8 T.S. , 1.8 T.S. Sport , 2.0 T.S. , 2.5 V6		<b>F8-6914</b>		
Belt Pulley, crankshaft	1.9 TD		<b>F8-7863</b>		
Control Arm-/Trailing Arm Bush	All Models		<b>G9-530</b>		H=50; d=20; D=41
Bellow, steering	2.0 T.S.	with clamps;	<b>LM-10060S</b>		d1=10; d2=48; L [mm]=170
<b>156 (932)</b>				<b>09/1997 → 09/2005</b>	
Dust Cover Kit, shock absorber	1.6 16V T.SPARK , 1.8 16V T.SPARK , 1.9 JTD , 1.9 JTD 16V, 2.0 16V T.SPARK , 2.0 JTS , 2.4 JTD		<b>AK-735066</b>		
Dust Cover Kit, shock absorber	1.6 16V T.SPARK , 1.8 16V T.SPARK , 1.9 JTD , 1.9 JTD 16V, 2.0 16V T.SPARK , 2.4 JTD, 2.5 V6 24V		<b>AK-735111</b>		
Alternator Freewheel Clutch	2.4 JTD		<b>F5-1108</b>		
Alternator Freewheel Clutch	1.9 JTD , 1.9 JTD 16V, 2.4 JTD		<b>F5-1123</b>		
Anti-Friction Bearing	1.6 16V T.SPARK , 1.8 16V T.SPARK , 1.9 JTD , 2.0 16V T.SPARK , 2.4 JTD , 2.5 V6 24V		<b>F8-3015</b>		H=48; d1=79; d2=84; D1=116; D2=128
Top Strut Mounting	1.6 16V T.SPARK , 1.8 16V T.SPARK , 1.9 JTD , 1.9 JTD 16V, 2.0 16V T.SPARK , 2.0 JTS , 2.4 JTD, 2.5 V6 24V , 3.2 GTA		<b>F8-6289</b>		
Top Strut Mounting	1.6 16V T.SPARK , 1.8 16V T.SPARK , 1.9 JTD , 1.9 JTD 16V, 2.0 16V T.SPARK , 2.0 JTS , 2.4 JTD, 2.5 V6 24V	ch.→0116246	<b>F8-6353</b>		
Top Strut Mounting	3.2 GTA		<b>F8-6353</b>		
Belt Pulley, crankshaft	1.9 JTD	Number of Ribs: 5; Parameter: 6PK; with screw set	<b>F8-6393</b>		D=169
Engine Mounting	1.6 16V T.SPARK	AR32103, AR32104, AR67601	<b>F8-6631</b>		
Engine Mounting	1.8 16V T.SPARK , 2.0 16V T.SPARK , 2.0 JTS		<b>F8-6631</b>		

<b>AK-735066</b>	<b>AK-735088</b>	<b>AK-735111</b>	<b>AK-735337</b>		<b>F5-1108</b>	<b>F5-1123</b>	<b>F8-3015</b>
Ref.Nr.: 60650551	Ref.Nr.: 60585431	Ref.Nr.:	Ref.Nr.: 7599485		Ref.Nr.: 46441617	Ref.Nr.: 9948513	Ref.Nr.: 7601502
<b>F8-5605</b>	<b>F8-5606</b>	<b>F8-5956</b>	<b>F8-6289</b>	<b>F8-6353</b>	<b>F8-6393</b>	<b>F8-6631</b>	
Ref.Nr.: 60570731	Ref.Nr.: 60570732	Ref.Nr.: 7602150	Ref.Nr.: 60625002	Ref.Nr.: 60613572	Ref.Nr.: 55196301	Ref.Nr.: 077 824 35	
<b>F8-6914</b>	<b>F8-7863</b>	<b>G9-530</b>	<b>LM-10038S</b>	<b>LM-10060S</b>			
Ref.Nr.: 60805971	Ref.Nr.: 0515K4	Ref.Nr.: 7601064	Ref.Nr.: 9947921	Ref.Nr.: 9938779			

<b>Article Description</b>			<b>Article Nr.</b>	<b>Fitting Position</b>	
----------------------------	--	--	--------------------	-------------------------	--

<b>156 (932)</b>			<b>09/1997 → 09/2005</b>		
Engine Mounting	2.5 V6 24V , 3.2 GTA		<b>F8-6914</b>		
Belt Pulley, crankshaft	2.4 JTD	Number of Ribs: 6	<b>F8-7087</b>		Belt Pulley Ø [mm]=181; Mounting points diam.[mm]=30; W=32
Bellow, steering	1.6 16V T.SPARK, 1.8 16V T.SPARK , 1.9 JTD , 1.9 JTD 16V, 2.0 JTS , 2.4 JTD , 2.5 V6 24V , 3.2 GTA	ch.→0648201; with clamps	<b>LM-10038S</b>		d1=12; d2=61; L [mm]=210
Bellow, steering	1.8 16V T.SPARK , 1.9 JTD , 2.0 16V T.SPARK , 2.0 Twin Spark, 2.4 JTD , 2.5 V6 24V	with clamps	<b>LM-10038S</b>		d1=12; d2=61; L [mm]=210
<b>156 Sportwagon (932)</b>			<b>01/2000 → 05/2006</b>		
Dust Cover Kit, shock absorber	1.6 16V T.SPARK , 1.8 16V T.SPARK , 1.9 JTD , 1.9 JTD 16V, 2.0 16V T.SPARK , 2.0 JTS , 2.4 JTD	not for equipment variant: Distinctive	<b>AK-735066</b>		
Dust Cover Kit, shock absorber	1.9 JTD 16V Q4		<b>AK-735066</b>		
Dust Cover Kit, shock absorber	1.6 16V T.SPARK , 1.8 16V T.SPARK , 1.9 JTD , 1.9 JTD 16V, 1.9 JTD 16V Q4, 2.0 16V T.SPARK , 2.4 JTD, 2.5 V6 24V		<b>AK-735111</b>		
Alternator Freewheel Clutch	1.9 JTD , 1.9 JTD 16V, 1.9 JTD 16V Q4, 2.4 JTD		<b>F5-1123</b>		
Top Strut Mounting	1.6 16V T.SPARK , 1.8 16V T.SPARK , 1.9 JTD , 1.9 JTD 16V, 2.0 16V T.SPARK , 2.0 JTS , 2.4 JTD, 2.5 V6 24V , 3.2 GTA		<b>F8-6289</b>		
Top Strut Mounting	1.6 16V T.SPARK , 1.8 16V T.SPARK , 1.9 JTD , 1.9 JTD 16V, 1.9 JTD 16V Q4, 2.0 16V T.SPARK , 2.0 JTS , 2.4 JTD , 2.5 V6 24V , 3.2 GTA		<b>F8-6353</b>		
Belt Pulley, crankshaft	1.9 JTD	Number of Ribs: 5; Parameter: 6PK; with screw set	<b>F8-6393</b>		D=169
Engine Mounting	1.6 16V T.SPARK.	AR32104, AR67601	<b>F8-6631</b>		
Engine Mounting	1.8 16V T.SPARK , 2.0 16V T.SPARK , 2.0 JTS		<b>F8-6631</b>		
Engine Mounting	2.5 V6 24V , 3.2 GTA		<b>F8-6914</b>		
Belt Pulley, crankshaft	2.4 JTD	Number of Ribs: 6	<b>F8-7087</b>		Belt Pulley Ø [mm]=181; Mounting points diam.[mm]=30; W=32
Bellow, steering	1.6 16V T.SPARK, 1.6 16V T.SPARK , 1.8 16V T.SPARK , 1.9 JTD , 1.9 JTD 16V, 1.9 JTD 16V Q4, 2.0, 2.0 JTS , 2.4 JTD , 2.5 V6 24V , 3.2 GTA	ch.→0648201; with clamps	<b>LM-10038S</b>		d1=12; d2=61; L [mm]=210
Bellow, steering	1.8 16V T.SPARK , 1.9 JTD , 2.0 16V T.SPARK , 2.4 JTD , 2.5 V6 24V	with clamps	<b>LM-10038S</b>		d1=12; d2=61; L [mm]=210
<b>159 (939)</b>			<b>09/2005 → 11/2011</b>		
Dust Cover Kit, shock absorber	1.8 MPI, 1.9 JTDM 16V, 1.9 JTDM 8V, 1.9 JTS, 2.2 JTS, 2.4 JTDM, 2.4 JTDM Q4, 3.2 JTS Q4		<b>AK-735314</b>		
Alternator Freewheel Clutch	2.4 JTDM, 2.4 JTDM Q4		<b>F5-1067</b>		
Alternator Freewheel Clutch	1.9 JTDM 16V, 1.9 JTDM 8V, 2.0 JTDM		<b>F5-1098</b>		
Alternator Freewheel Clutch	1.9 JTDM 16V, 1.9 JTDM 8V		<b>F5-1123</b>		
Alternator Freewheel Clutch	1.8 Tbi		<b>F5-1147</b>		

<b>AK-735066</b>	<b>AK-735111</b>	<b>AK-735314</b>	<b>F5-1067</b>	<b>F5-1098</b>	<b>F5-1123</b>	<b>F5-1147</b>
Ref.Nr.: 60650551	Ref.Nr.:	Ref.Nr.: 50707987	Ref.Nr.: 77364148	Ref.Nr.: 77364725	Ref.Nr.: 9948513	Ref.Nr.: 77365271
<b>F8-6289</b>	<b>F8-6353</b>	<b>F8-6393</b>	<b>F8-6437</b>	<b>F8-6631</b>	<b>F8-6914</b>	<b>F8-7087</b>
Ref.Nr.: 60625002	Ref.Nr.: 60613572	Ref.Nr.: 55196301	Ref.Nr.: 50706955	Ref.Nr.: 077 824 35	Ref.Nr.: 60805971	Ref.Nr.: 55184474
<b>LM-10038S</b>						
Ref.Nr.: 9947921						

**Article Description****Article Nr.****Fitting Position**

<b>159 (939)</b>			<b>09/2005 → 11/2011</b>		
Control Arm-/Trailing Arm Bush	1.8 MPI, 1.9 JTDM 16V, 1.9 JTDM 8V, 1.9 JTS, 2.2 JTS, 2.4 JTDM, 2.4 JTDM Q4, 3.2 JTS Q4		<b>F8-6437</b>		
Control Arm-/Trailing Arm Bush	1.8 MPI, 1.9 JTDM 16V, 1.9 JTDM 8V, 1.9 JTS, 2.2 JTS, 2.4 JTDM, 2.4 JTDM Q4, 3.2 JTS Q4		<b>F8-6438</b>		
Control Arm-/Trailing Arm Bush	1.8 MPI, 1.9 JTDM 16V, 1.9 JTDM 8V, 1.9 JTS, 2.2 JTS, 2.4 JTDM, 2.4 JTDM Q4, 3.2 JTS Q4		<b>F8-6457</b>		
Belt Pulley, crankshaft	2.4 JTDM, 2.4 JTDM Q4	Number of Ribs: 6	<b>F8-7087</b>		Belt Pulley Ø [mm]=181; Mounting points diam.[mm]=30; W=32
Top Strut Mounting	All Models		<b>F8-7419</b>		
Top Strut Mounting	All Models		<b>F8-7420</b>		
<b>159 Sportwagon (939)</b>			<b>03/2006 → 11/2011</b>		
Dust Cover Kit, shock absorber	1.8 MPI, 1.9 JTDM 16V, 1.9 JTDM 8V, 1.9 JTS, 2.2 JTS, 2.4 JTDM, 2.4 JTDM Q4, 3.2 JTS Q4		<b>AK-735314</b>		
Alternator Freewheel Clutch	2.4 JTDM, 2.4 JTDM Q4		<b>F5-1067</b>		
Alternator Freewheel Clutch	1.9 JTDM 16V, 1.9 JTDM 8V, 2.0 JTDM		<b>F5-1098</b>		
Alternator Freewheel Clutch	1.9 JTDM 16V, 1.9 JTDM 8V		<b>F5-1123</b>		
Alternator Freewheel Clutch	1.8 Tbi		<b>F5-1147</b>		
Control Arm-/Trailing Arm Bush	1.8 MPI, 1.9 JTDM 16V, 1.9 JTDM 8V, 1.9 JTS, 2.2 JTS, 2.4 JTDM, 2.4 JTDM Q4, 3.2 JTS Q4		<b>F8-6437</b>		
Control Arm-/Trailing Arm Bush	1.8 MPI, 1.9 JTDM 16V, 1.9 JTDM 8V, 1.9 JTS, 2.2 JTS, 2.4 JTDM, 2.4 JTDM Q4, 3.2 JTS Q4		<b>F8-6438</b>		
Control Arm-/Trailing Arm Bush	1.8 MPI, 1.9 JTDM 16V, 1.9 JTDM 8V, 1.9 JTS, 2.2 JTS, 2.4 JTDM, 2.4 JTDM Q4, 3.2 JTS Q4		<b>F8-6457</b>		
Belt Pulley, crankshaft	2.4 JTDM, 2.4 JTDM Q4	Number of Ribs: 6	<b>F8-7087</b>		Belt Pulley Ø [mm]=181; Mounting points diam.[mm]=30; W=32
Top Strut Mounting	All Models		<b>F8-7419</b>		
Top Strut Mounting	All Models		<b>F8-7420</b>		
<b>164 (164)</b>			<b>06/1987 → 09/1998</b>		
Dust Cover Kit, shock absorber	2.0, 2.0 T.S., 2.0 Turbo, 2.0 V6 Turbo, 2.5 TD, 2.5 V6, 3.0 24V, 3.0 24V Q4, 3.0 24V QV, 3.0 i.e. QV, 3.0 V6		<b>AK-735152</b>		
Anti-Friction Bearing	2.0 T.S., 2.0 V6 Turbo, 2.5 TD, 3.0 24V, 3.0 24V QV, 3.0 i.e. QV, 3.0 V6		<b>F8-3062</b>		H=14; d=62; D=90
Top Strut Mounting	2.0 T.S., 2.0 V6 Turbo, 2.5 TD, 2.5 V6, 3.0 24V, 3.0 24V Q4, 3.0 24V QV		<b>F8-5593</b>		
Top Strut Mounting	2.0, 2.0 T.S., 2.5 TD, 3.0 i.e. QV, 3.0 V6	10/1990 →;	<b>F8-5593</b>		
Top Strut Mounting	2.0, 2.0 T.S., 2.0 Turbo, 2.0 V6 Turbo, 2.5 TD, 3.0, 3.0 24V, 3.0 24V Q4, 3.0 24V QV, 3.0 All-wheel Drive, 3.0 i.e. QV, 3.0 V6		<b>F8-5603</b>		H=50; d=14; D=145
Top Strut Mounting	2.0, 2.0 T.S., 2.5 TD, 3.0 i.e. QV, 3.0 V6		<b>F8-5607</b>		





Article Description			Article Nr.	Fitting Position	
<b>06/1987 → 09/1998</b>					
<b>164 (164)</b>					
Mounting, axle beam	2.0 T.S.		F8-5640		
Bellow, steering	2.0 T.S. , 2.0 Turbo, 2.0 V6 Turbo, 2.5 TD , 3.0 24V , 3.0 24V Q4 , 3.0 24V QV , 3.0 V6	with clamps;	LM-10060S		d1=10; d2=48; L [mm]=170
<b>09/1998 → 06/2007</b>					
<b>166 (936)</b>					
Dust Cover Kit, shock absorber	2.0 T. Spark , 2.0 V6 , 2.4 JTD, 2.5 V6 24V , 3.0 V6 24V , 3.2 V6 24V		AK-735124		
Alternator Freewheel Clutch	2.4 JTD		F5-1123		
Top Strut Mounting	2.0 T. Spark , 2.0 V6 , 2.4 JTD, 2.5 V6 24V , 3.0 V6 24V , 3.2 V6 24V		F8-6289		
Belt Pulley, crankshaft	2.4 JTD	10/1998 →; Number of Ribs: 6	F8-7087		Belt Pulley Ø [mm]=181; Mounting points diam.[mm]=30; W=32
Belt Pulley, crankshaft	2.4 JTD	Number of Ribs: 6	F8-7087		Belt Pulley Ø [mm]=181; Mounting points diam.[mm]=30; W=32
Bellow, steering	2.0 T. Spark , 2.0 V6 , 2.4 JTD , 2.5 V6 24V , 3.0 V6 24V , 3.2 V6 24V	with clamps	LM-10038S		d1=12; d2=61; L [mm]=210
<b>06/1972 → 12/1984</b>					
<b>ALFASUD (901)</b>					
Dust Cover Kit, shock absorber	All Models	Universal	AK-735151		
Top Strut Mounting	1.2 , 1.2 ti , 1.3 SC/ti Super , 1.3 Super , 1.3 ti , 1.5 ti , 1.5 ti Sprint		F8-5604		
<b>09/1976 → 12/1989</b>					
<b>ALFASUD Sprint (902.A)</b>					
Dust Cover Kit, shock absorber	All Models	Universal	AK-735151		
Top Strut Mounting	1.4, 1.5 , 1.5 Veloce, 1.7, 1.7 i.e.		F8-5604		
<b>01/1978 → 12/1981</b>					
<b>ALFASUD Giardinetta (904)</b>					
Dust Cover Kit, shock absorber	All Models	Universal	AK-735151		
<b>07/1974 → 12/1984</b>					
<b>ALFETTA (116)</b>					
Control Arm-/Trailing Arm Bush	All Models		F8-6456		d=17; D=38
Bellow, steering	All Models	with clamps;	LM-10037S		d1=12; d2=47; L [mm]=180
Bellow, steering	1.6 , 1.8 , 2.0 , 2.0 TD	with clamps	LM-10062S		d1=10; d2=46; L [mm]=145
<b>01/1974 → 01/1986</b>					
<b>ALFETTA GT (116)</b>					
Control Arm-/Trailing Arm Bush	All Models		F8-6456		d=17; D=38
Bellow, steering	1.6, 2.0	with clamps;	LM-10037S		d1=12; d2=47; L [mm]=180
Bellow, steering	1.8	06/1974 →; with clamps;	LM-10037S		d1=12; d2=47; L [mm]=180
Bellow, steering	2.0	with clamps;	LM-10037S		d1=12; d2=47; L [mm]=180
Bellow, steering	All Models	with clamps	LM-10062S		d1=10; d2=46; L [mm]=145

<b>AK-735124</b>	<b>AK-735151</b>	<b>F5-1123</b>	<b>F8-5604</b>	<b>F8-5640</b>	<b>F8-6289</b>	<b>F8-6456</b>
Ref.Nr.:	Ref.Nr.:	Ref.Nr.: 9948513	Ref.Nr.: 40504729	Ref.Nr.: 82388242	Ref.Nr.: 60625002	Ref.Nr.: 60521240
<b>F8-7087</b>	<b>LM-10037S</b>	<b>LM-10038S</b>	<b>LM-10060S</b>	<b>LM-10062S</b>		
Ref.Nr.: 55184474	Ref.Nr.: 60724154	Ref.Nr.: 9947921	Ref.Nr.: 9938779	Ref.Nr.: 1568676		

**Article Description****Article Nr.****Fitting Position**

<b>ARNA (920)</b>			<b>03/1983 → 12/1986</b>		
Dust Cover Kit, shock absorber	All Models	Universal	<b>AK-735151</b>		
Control Arm-/Trailing Arm Bush	1.2, 1.3, 1.3 TI, 1.5		<b>F8-6456</b>		d=17; D=38
<b>BRERA (939)</b>			<b>01/2006 → 06/2010</b>		
Alternator Freewheel Clutch	2.4 JTDM 20V		<b>F5-1067</b>		
Alternator Freewheel Clutch	2.0 JTDM		<b>F5-1098</b>		
Alternator Freewheel Clutch	1.8 Tbi		<b>F5-1147</b>		
Control Arm-/Trailing Arm Bush	2.2 JTS, 2.4 JTDM 20V, 3.2 JTS Q4		<b>F8-6437</b>		
Control Arm-/Trailing Arm Bush	2.2 JTS, 2.4 JTDM 20V, 3.2 JTS Q4		<b>F8-6438</b>		
Control Arm-/Trailing Arm Bush	2.2 JTS, 2.4 JTDM 20V, 3.2 JTS Q4		<b>F8-6457</b>		
Belt Pulley, crankshaft	2.4 JTDM 20V	Number of Ribs: 6	<b>F8-7087</b>		Belt Pulley Ø [mm]=181; Mounting points diam.[mm]=30; W=32
Top Strut Mounting	All Models		<b>F8-7419</b>		
Top Strut Mounting	All Models		<b>F8-7420</b>		
<b>GIULIA (105_)</b>			<b>01/1974 → 12/1978</b>		
Control Arm-/Trailing Arm Bush	1300 Super, 1600 Super		<b>F8-6456</b>		d=17; D=38
<b>GIULIETTA (116)</b>			<b>10/1977 → 12/1985</b>		
Control Arm-/Trailing Arm Bush	All Models		<b>F8-6456</b>		d=17; D=38
Bellow, steering	All Models	with clamps;	<b>LM-10037S</b>		d1=12; d2=47; L [mm]=180
<b>GIULIETTA (940)</b>			<b>04/2010 →</b>		
Alternator Freewheel Clutch	1.6 JTDM, 1.8 Tbi, 2.0 JTDM		<b>F5-1072</b>		
Alternator Freewheel Clutch	1.8 Tbi		<b>F5-1147</b>		
<b>GT (937)</b>			<b>11/2003 → 09/2010</b>		
Dust Cover Kit, shock absorber	1.8 TS, 2.0 JTS		<b>AK-735066</b>		
Alternator Freewheel Clutch	1.9 JTD		<b>F5-1123</b>		
Top Strut Mounting	1.8 TS, 1.9 JTD, 2.0 JTS, 3.2 GTA		<b>F8-6289</b>		
Belt Pulley, crankshaft	1.9 JTD	Number of Ribs: 5; Parameter: 6PK; with screw set	<b>F8-6393</b>		D=169
Engine Mounting	3.2 GTA		<b>F8-6914</b>		
Top Strut Mounting	1.8 TS, 1.9 JTD, 2.0 JTS, 3.2 GTA		<b>F8-7418</b>		
Bellow, steering	1.8 TS, 1.9 JTD, 2.0 JTS, 3.2 GTA	with clamps	<b>LM-10038S</b>		d1=12; d2=61; L [mm]=210

<b>AK-735066</b>	<b>AK-735151</b>	<b>F5-1067</b>	<b>F5-1072</b>	<b>F5-1098</b>	<b>F5-1123</b>	<b>F5-1147</b>
Ref.Nr.: 60650551	Ref.Nr.:	Ref.Nr.: 77364148	Ref.Nr.: 30667067	Ref.Nr.: 77364725	Ref.Nr.: 9948513	Ref.Nr.: 77365271
<b>F8-6289</b>	<b>F8-6393</b>	<b>F8-6437</b>	<b>F8-6438</b>	<b>F8-6456</b>	<b>F8-6457</b>	<b>F8-6914</b>
Ref.Nr.: 60625002	Ref.Nr.: 55196301	Ref.Nr.: 50706955	Ref.Nr.: 50706954	Ref.Nr.: 60521240	Ref.Nr.:	Ref.Nr.: 60805971
<b>F8-7087</b>	<b>F8-7418</b>	<b>F8-7419</b>	<b>F8-7420</b>	<b>LM-10037S</b>	<b>LM-10038S</b>	
Ref.Nr.: 55184474	Ref.Nr.: 46791956	Ref.Nr.: 50705805	Ref.Nr.: 50704983	Ref.Nr.: 60724154	Ref.Nr.: 9947921	

Article Description



Article Nr.

Fitting Position



			01/1978 → 02/1987		
Control Arm-/Trailing Arm Bush	All Models		F8-6456		d=17; D=38
Bellow, steering	All Models	with clamps;	LM-10037S		d1=12; d2=47; L [mm]=180
GTV (916C_)			06/1995 → 10/2005		
Engine Mounting	1.8 16V , 2.0 JTS, 2.0 T.SPARK 16V		F8-6631		
Control Arm-/Trailing Arm Bush	1.8 16V , 2.0 T.SPARK 16V , 2.0 V6 Turbo , 3.0 V6 24V		G9-530		H=50; d=20; D=41
MITO (955)			09/2008 →		
Alternator Freewheel Clutch	1.3 JTDM		F5-1041		
Alternator Freewheel Clutch	1.3 JTDM		F5-1045		
Alternator Freewheel Clutch	1.6 JTDM		F5-1098		
Top Strut Mounting	1.3 JTDM, 1.4, 1.4 TB, 1.4 Turbo, 1.6 JTDM		F8-7421		
Spring Cap	1.3 JTDM, 1.4, 1.4 TB, 1.4 Turbo, 1.6 JTDM		F8-7422		
Top Strut Mounting	1.3 JTDM, 1.4, 1.4 TB, 1.4 Turbo, 1.6 JTDM		F8-7423		
Top Strut Mounting	1.3 JTDM, 1.4, 1.4 TB, 1.4 Turbo, 1.6 JTDM		F8-7424		
Protective Cap/Bellow, shock absorber	0.9, 1.3 JTDM, 1.4, 1.4 Bifuel, 1.4 TB, 1.4 Turbo, 1.6 JTDM		F8-7663		H=205
Control Arm-/Trailing Arm Bush	0.9, 1.3 JTDM, 1.4, 1.4 Bifuel, 1.4 TB, 1.4 Turbo, 1.6 JTDM		F8-7995		
RZ			01/1992 → 12/1994		
Control Arm-/Trailing Arm Bush	All Models		F8-6456		d=17; D=38
SPIDER (916S_ , 916_)			09/1994 → 04/2005		
Engine Mounting	1.8 16V , 2.0 JTS, 2.0 T.SPARK 16V		F8-6631		
Control Arm-/Trailing Arm Bush	1.8 16V , 2.0 T.SPARK 16V , 2.0 V6 Turbo , 3.0 V6 , 3.0 V6 24V		G9-530		H=50; d=20; D=41
SPIDER (939, 939_)			03/2006 → 06/2010		
Alternator Freewheel Clutch	2.4 JTDM		F5-1067		
Alternator Freewheel Clutch	2.0 JTDM		F5-1098		
Alternator Freewheel Clutch	1.8 TBi		F5-1147		
Control Arm-/Trailing Arm Bush	2.2 JTS, 2.4 JTDM, 3.2 JTS Q4		F8-6437		
Control Arm-/Trailing Arm Bush	2.2 JTS, 2.4 JTDM, 3.2 JTS Q4		F8-6438		
Control Arm-/Trailing Arm Bush	2.2 JTS, 2.4 JTDM, 3.2 JTS Q4		F8-6457		
Belt Pulley, crankshaft	2.4 JTDM	Number of Ribs: 6	F8-7087		Belt Pulley Ø [mm]=181; Mounting points diam.[mm]=30; W=32

F5-1041	F5-1045	F5-1067	F5-1098	F5-1147	F8-6437	F8-6438
Ref.Nr.: 77364723	Ref.Nr.: 77362721	Ref.Nr.: 77364148	Ref.Nr.: 77364725	Ref.Nr.: 77365271	Ref.Nr.: 50706955	Ref.Nr.: 50706954
F8-6456	F8-6457	F8-6631	F8-7087	F8-7419	F8-7421	F8-7422
Ref.Nr.: 60521240	Ref.Nr.:	Ref.Nr.: 077 824 35	Ref.Nr.: 55184474	Ref.Nr.: 50705805	Ref.Nr.: 51813225	Ref.Nr.: 344963
F8-7423	F8-7424	F8-7663	F8-7995	G9-530	LM-10037S	
Ref.Nr.: 55701902	Ref.Nr.: 55703318	Ref.Nr.: 344435	Ref.Nr.: 55700751	Ref.Nr.: 7601064	Ref.Nr.: 60724154	



Article Description

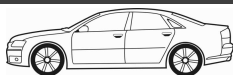

Article Nr.

Fitting Position



<b>SPIDER (939, 939_)</b>		<b>03/2006 → 06/2010</b>	
Top Strut Mounting	All Models	<b>F8-7419</b>	
Top Strut Mounting	All Models	<b>F8-7420</b>	
<b>SZ</b>		<b>09/1988 → 08/1994</b>	
Control Arm-/Trailing Arm Bush	All Models	<b>F8-6456</b>	d=17; D=38

<b>F8-6456</b>	<b>F8-7419</b>	<b>F8-7420</b>
Ref.Nr.: 60521240	Ref.Nr.: 50705805	Ref.Nr.: 50704983

Article Description

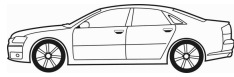

Article Nr.

Fitting Position



<b>50 (86)</b>		<b>08/1974 → 07/1978</b>	
Dust Cover Kit, shock absorber	0.8, 1.1, 1.3		AK-735014
Dust Cover Kit, shock absorber	1.1	08/1975 →	AK-735014
Dust Cover Kit, shock absorber	1.1, 1.3		AK-735027
Dust Cover Kit, shock absorber	1.1, 1.3		AK-735098
Flange, carburettor	1.1		F8-4013  H1=84; H2=95; d=36; τ [mm]=68
Control Arm-/Trailing Arm Bush	1.1, 1.3		F8-4042  H=44; d=10; D1=38; D2=42
Stabiliser Mounting	1.1, 1.3		F8-5132
Stabiliser Mounting	1.1, 1.3		F8-5148  d=16.5; D=125.24
Top Strut Mounting	All Models		F8-5738
<b>80 (80, 82, B1)</b>		<b>05/1972 → 07/1978</b>	
Dust Cover Kit, shock absorber	1.3, 1.5, 1.6, 1.6 GT, 1.6 GTE		AK-735002
Dust Cover Kit, shock absorber	1.3, 1.5, 1.6, 1.6 GT, 1.6 GTE		AK-735006
Dust Cover Kit, shock absorber	1.3, 1.5, 1.6, 1.6 GT, 1.6 GTE		AK-735027
Stabiliser Mounting	1.3, 1.5, 1.6, 1.6 GT, 1.6 GTE		F8-1029  H=42; Thick. [mm]=25; W=38
Engine Mounting	1.3, 1.5, 1.6, 1.6 GT, 1.6 GTE		F8-1031  H=47; d=10; D1=36; D2=52
Engine Mounting	1.3, 1.5, 1.6, 1.6 GT, 1.6 GTE		F8-3000  H=60; Thick. [mm]=66; W=89
Engine Mounting	1.3, 1.5, 1.6, 1.6 GT, 1.6 GTE		F8-3000  H=60; Thick. [mm]=66; W=89
Anti-Friction Bearing	1.3, 1.6, 1.6 GT, 1.6 GTE		F8-3036
Flange, carburettor	1.6	ch.82-62000001→; 01/1976 →	F8-3046  H=23
Mounting, radiator	1.3, 1.5, 1.6, 1.6 GT		F8-4011  H1=16; H2=38; D=30; Outer Thread [mm]=M8 x 1,25
Rubber Buffer, silencer	1.5		F8-4026  H=12; W=57, 60
Control Arm-/Trailing Arm Bush	1.3, 1.5, 1.6, 1.6 GT, 1.6 GTE		F8-4042  H=44; d=10; D1=38; D2=42
Bellow, driveshaft	1.6		F8-4080  H=95; D1=29; D2=96
Stabiliser Mounting	1.3, 1.5, 1.6, 1.6 GT, 1.6 GTE		F8-5225  d=19
Engine Mounting	1.3, 1.5, 1.6, 1.6 GT, 1.6 GTE		F8-5685  H=36; d=10; D=40.5
Top Strut Mounting	1.3, 1.5, 1.6, 1.6 GT, 1.6 GTE		F8-5905
<b>80 (81, 85, B2)</b>		<b>08/1978 → 08/1986</b>	
Dust Cover Kit, shock absorber	1.8	△	AK-732516
Dust Cover Kit, shock absorber	1.3, 1.6, 1.6 D, 1.6 GLE, 1.6 TD, 1.8, 1.8 CC quattro , 1.8 GTE, 1.8 GTE quattro , 1.9 CD-5S, 2.0, 2.0 quattro , 2.2, 2.2 quattro		AK-735002
Dust Cover Kit, shock absorber	1.3, 1.6, 1.6 D, 1.6 GLE, 1.6 TD, 1.8, 1.8 CC quattro , 1.8 GTE, 1.8 GTE quattro , 1.9 CD-5S, 2.0 quattro , 2.2 quattro		AK-735006

<b>AK-732516</b>	<b>AK-735002</b>	<b>AK-735006</b>	<b>AK-735014</b>	<b>AK-735027</b>	<b>AK-735098</b>	<b>F8-1029</b>
Ref.Nr.:	Ref.Nr.:	Ref.Nr.:	Ref.Nr.:	Ref.Nr.:	Ref.Nr.:	Ref.Nr.: 823411313A
<b>F8-1031</b>	<b>F8-3000</b>	<b>F8-3036</b>	<b>F8-3046</b>	<b>F8-4011</b>	<b>F8-4013</b>	<b>F8-4026</b>
Ref.Nr.: 811199415A	Ref.Nr.: 823199381B	Ref.Nr.: 377412335A	Ref.Nr.: 049129761	Ref.Nr.: 803121273	Ref.Nr.: 052129765A	Ref.Nr.: 817253147
<b>F8-4042</b>	<b>F8-4080</b>	<b>F8-5132</b>	<b>F8-5148</b>	<b>F8-5225</b>	<b>F8-5685</b>	<b>F8-5738</b>
Ref.Nr.: 823407181	Ref.Nr.: 113501149	Ref.Nr.: 861407183	Ref.Nr.: 861411313E	Ref.Nr.: 823411327B	Ref.Nr.: 811199419A	Ref.Nr.: 871412323A



**Article Description****Article Nr.****Fitting Position**

<b>80 (81, 85, B2)</b>			<b>08/1978 → 08/1986</b>		
Dust Cover Kit, shock absorber	1.3, 1.6, 1.6 D, 1.6 GLE, 1.6 TD, 1.8, 1.8 CC quattro , 1.8 GTE, 1.8 GTE quattro , 1.9 CD-5S, 2.0, 2.0 quattro , 2.2, 2.2 quattro		<b>AK-735027</b>		
Dust Cover Kit, shock absorber	1.3, 1.6, 1.6 D, 1.6 GLE, 1.6 TD, 1.8, 1.8 CC quattro , 1.8 GTE, 1.8 GTE quattro , 1.9 CD-5S, 2.0, 2.0 quattro , 2.2, 2.2 quattro		<b>AK-735098</b>		
Control Arm-/Trailing Arm Bush	1.3, 1.6, 1.6 GLE, 1.6 TD, 1.8, 1.8 GTE, 1.9 CD-5S	ch.81-D-077974 →;	<b>F8-1026</b>		H=44; d=10; D1=38; D2=48
Control Arm-/Trailing Arm Bush	1.3, 2.0, 2.2		<b>F8-1026</b>		H=44; d=10; D1=38; D2=48
Control Arm-/Trailing Arm Bush	1.6 D	ch.81-D-077974 →; 01/1983 →;	<b>F8-1026</b>		H=44; d=10; D1=38; D2=48
Control Arm-/Trailing Arm Bush	2.2 quattro	ch. → 81-D-077974	<b>F8-1026</b>		H=44; d=10; D1=38; D2=48
Top Strut Mounting	1.3, 1.6, 1.6 D, 1.6 GLE, 1.6 TD, 1.8, 1.8 CC quattro , 1.8 GTE, 1.8 GTE quattro , 1.9 CD-5S, 2.0, 2.0 quattro , 2.2, 2.2 quattro		<b>F8-1027</b>		H=37; d1=14; d2=20; D=76
Mounting, axle beam	1.3, 1.6, 1.6 D, 1.6 GLE, 1.6 TD, 1.8, 1.8 GTE, 1.9 CD-5S		<b>F8-1028</b>		H1=28; H2=38; d=12,2; D=41
Stabiliser Mounting	1.3, 1.6, 1.6 GLE, 1.6 TD, 1.8, 1.8 GTE, 1.9 CD-5S	ch.81-D-077974 →;	<b>F8-1029</b>		H=42; Thick. [mm]=25; W=38
Stabiliser Mounting	1.6 D	ch.81-D-077974 →; 01/1983 →;	<b>F8-1029</b>		H=42; Thick. [mm]=25; W=38
Stabiliser Mounting	1.8		<b>F8-1029</b>		H=42; Thick. [mm]=25; W=38
Engine Mounting	1.3, 1.6		<b>F8-1031</b>		H=47; d=10; D1=36; D2=52
Engine Mounting	1.6, 1.6 D, 1.6 GLE, 1.6 TD, 1.8, 1.8 CC quattro , 1.8 GTE, 1.8 GTE quattro , 1.9 CD-5S, 2.0 quattro , 2.2 quattro	ch. → 8A-N-200000	<b>F8-1031</b>		H=47; d=10; D1=36; D2=52
Engine Mounting	1.3, 1.6, 1.6 D, 1.6 GLE, 1.6 TD, 1.8, 1.8 GTE	ch. → 8C-P-053245	<b>F8-1032</b>		D=10; H=42; D1=38; D2=46
Engine Mounting	1.3		<b>F8-3000</b>		H=60; Thick. [mm]=66; W=89
Engine Mounting	1.3		<b>F8-3000</b>		H=60; Thick. [mm]=66; W=89
Engine Mounting	1.6, 1.6 D, 1.6 GLE, 1.6 TD, 1.8, 1.8 GTE		<b>F8-3000</b>		H=60; Thick. [mm]=66; W=89
Engine Mounting	1.6, 1.8, 1.8 GTE		<b>F8-3000</b>		H=60; Thick. [mm]=66; W=89
Anti-Friction Bearing	1.3, 1.6, 1.6 D, 1.6 GLE, 1.6 TD, 1.8, 1.8 CC quattro , 1.8 GTE, 1.8 GTE quattro , 1.9 CD-5S, 2.0, 2.0 quattro , 2.2, 2.2 quattro		<b>F8-3036</b>		
Flange, carburettor	1.6	01/1983 →	<b>F8-3044</b>		H=21
Flange, carburettor	1.8		<b>F8-3044</b>		H=21
Flange, carburettor	1.3	01/1984 →	<b>F8-3045</b>		H=21
Flange, carburettor	1.6, 1.8, 1.8 CC quattro		<b>F8-3045</b>		H=21
Flange, carburettor	1.6		<b>F8-3046</b>		H=23
Flange, carburettor	1.6, 1.8		<b>F8-3047</b>		H=24

<b>AK-735027</b>	<b>AK-735098</b>	<b>F8-1026</b>	<b>F8-1027</b>	<b>F8-1028</b>	<b>F8-1029</b>	<b>F8-1031</b>
Ref.Nr.:	Ref.Nr.:	Ref.Nr.: 811407181A	Ref.Nr.: 811412323D	Ref.Nr.: 811511247	Ref.Nr.: 823411313A	Ref.Nr.: 811199415A
<b>F8-1032</b>	<b>F8-3000</b>	<b>F8-3036</b>	<b>F8-3044</b>	<b>F8-3045</b>	<b>F8-3046</b>	<b>F8-3047</b>
Ref.Nr.: 811199419B	Ref.Nr.: 823199381B	Ref.Nr.: 377412335A	Ref.Nr.: 026129761A	Ref.Nr.: 027129761	Ref.Nr.: 049129761	Ref.Nr.: 050129761C
<b>F8-4009</b>						
Ref.Nr.: 431121273						

Article Description			Article Nr.	Fitting Position	
<b>80 (81, 85, B2)</b>			<b>08/1978 → 08/1986</b>		
Mounting, radiator	1.3	ch.→81-F-045000; 01/1982 →; *	<b>F8-4009</b>		H1=15; H2=37; D=39; Outer Thread [mm]=M8 x 1,50
Mounting, radiator	1.3, 1.6, 1.8	ch.→81-F-045000; for hot climate zones	<b>F8-4009</b>		H1=15; H2=37; D=39; Outer Thread [mm]=M8 x 1,50
Mounting, radiator	1.6	01/1982 →; *	<b>F8-4009</b>		H1=15; H2=37; D=39; Outer Thread [mm]=M8 x 1,50
Mounting, radiator	1.6 D, 1.6 GLE, 1.6 TD, 1.8, 1.8 GTE	ch.→81-F-045000	<b>F8-4009</b>		H1=15; H2=37; D=39; Outer Thread [mm]=M8 x 1,50
Mounting, radiator	1.6 TD	ch.81-F-045001→; ch.→81-F-045000, 81-H-299999; for hot climate zones	<b>F8-4009</b>		H1=15; H2=37; D=39; Outer Thread [mm]=M8 x 1,50
Mounting, radiator	1.8	ch.→81-F-045000;  DS	<b>F8-4009</b>		H1=15; H2=37; D=39; Outer Thread [mm]=M8 x 1,50
Mounting, radiator	1.8 CC quattro , 1.8 GTE quattro	ch.→81-F-045000, 85-F-045000	<b>F8-4009</b>		H1=15; H2=37; D=39; Outer Thread [mm]=M8 x 1,50
Mounting, radiator	2.0, 2.0 quattro , 2.2, 2.2 quattro		<b>F8-4009</b>		H1=15; H2=37; D=39; Outer Thread [mm]=M8 x 1,50
Mounting, radiator	1.3, 1.6, 1.6 GLE, 1.8, 1.8 CC quattro , 1.8 GTE quattro , 1.9 CD-5S, 2.0, 2.0 quattro , 2.2, 2.2 quattro		<b>F8-4011</b>		H1=16; H2=38; D=30; Outer Thread [mm]=M8 x 1,25
Mounting, radiator	1.6 TD	ch.→81-F-045000	<b>F8-4011</b>		H1=16; H2=38; D=30; Outer Thread [mm]=M8 x 1,25
Flange, carburettor	1.8		<b>F8-4012</b>		H=20; L=146; W=112
Rubber Buffer, silencer	1.3, 1.6, 1.6 D		<b>F8-4026</b>		H=12; W=57, 60
Clamp, silencer	1.8 CC quattro , 1.8 GTE quattro , 2.0 quattro , 2.2 quattro		<b>F8-4027</b>		H=17; W=53, 61
Mounting, automatic transmission	1.8 CC quattro , 1.8 GTE quattro , 2.0 quattro		<b>F8-4028</b>		H=42; D=11; D1=50; D2=80; T [mm]=94
Mounting, automatic transmission	2.2 quattro		<b>F8-4028</b>		H=42; D=11; D1=50; D2=80; T [mm]=94
Mounting, manual transmission	1.3, 1.6, 1.6 GLE	ch.81-A-173589→; 01/1980 →	<b>F8-4030</b>		H=50; d=14; D=84
Mounting, manual transmission	1.6, 1.6 D, 1.6 TD, 1.8, 1.8 GTE	ch.81-A-173589→	<b>F8-4030</b>		H=50; d=14; D=84
Control Arm-/Trailing Arm Bush	1.3, 1.6, 1.6 D, 1.6 TD, 1.9 CD-5S	01/1983 →	<b>F8-4043</b>		H=44; d=10; D1=37; D2=54
Control Arm-/Trailing Arm Bush	1.6, 1.8, 1.8 CC quattro , 1.8 GTE, 1.8 GTE quattro , 2.0, 2.0 quattro , 2.2 quattro		<b>F8-4043</b>		H=44; d=10; D1=37; D2=54
Rubber Buffer, suspension	1.3, 1.6, 1.6 D, 1.6 GLE, 1.6 TD, 1.8, 1.8 CC quattro , 1.8 GTE, 1.8 GTE quattro , 1.9 CD-5S, 2.0, 2.0 quattro , 2.2, 2.2 quattro		<b>F8-4062</b>		H=67; d1=20; d2=24; D=52
Protective Cap/Bellow, shock absorber	1.3, 1.6, 1.6 D, 1.6 GLE, 1.6 TD, 1.8, 1.8 GTE, 1.8 GTE quattro , 1.9 CD-5S, 2.0, 2.0 quattro , 2.2, 2.2 quattro		<b>F8-4065</b>		H=97; d1=46; d2=76
Protective Cap/Bellow, shock absorber	1.3, 1.6, 1.6 D, 1.6 GLE, 1.6 TD, 1.8, 1.8 GTE, 1.8 GTE quattro , 1.9 CD-5S, 2.0, 2.0 quattro , 2.2, 2.2 quattro		<b>F8-4065</b>		H=97; d1=46; d2=76
Bellow, steering	1.3, 1.6, 1.6 D, 1.6 GLE, 1.6 TD	ch.81-A0173589→	<b>F8-4073</b>		H=147; D=48

<b>F8-4009</b>	<b>F8-4011</b>	<b>F8-4012</b>	<b>F8-4026</b>	<b>F8-4027</b>	<b>F8-4028</b>	<b>F8-4030</b>
Ref.Nr.: 431121273	Ref.Nr.: 803121273	Ref.Nr.: 050129761D	Ref.Nr.: 817253147	Ref.Nr.: 171253147A	Ref.Nr.: 431399151D	Ref.Nr.: 811399151B
<b>F8-4043</b>	<b>F8-4062</b>	<b>F8-4065</b>	<b>F8-4073</b>			
Ref.Nr.: 8A0407181	Ref.Nr.: 811412131A	Ref.Nr.: 811412135A	Ref.Nr.: 811419831B			

**Article Description****Article Nr.****Fitting Position****80 (81, 85, B2)****08/1978 → 08/1986**

Bellow, steering	1.6, 1.8, 1.8 CC quattro , 1.8 GTE, 1.8 GTE quattro , 1.9 CD-5S, 2.0, 2.0 quattro , 2.2, 2.2 quattro		<b>F8-4073</b>		H=147; D=48
Bellow, driveshaft	1.3, 1.6, 1.6 D, 1.6 GLE, 1.6 TD, 1.8, 1.8 CC quattro , 1.8 GTE, 1.8 GTE quattro , 1.9 CD-5S		<b>F8-4080</b>		H=95; D1=29; D2=96
Rubber Buffer, suspension	1.3, 1.6, 1.6 D, 1.6 GLE, 1.6 TD, 1.8, 1.8 GTE, 1.9 CD-5S, 2.0, 2.2		<b>F8-4085</b>		H=84; d1=11; d2=15; D1=35; D2=48
Stabiliser Mounting	1.3, 1.6, 1.6 D, 1.6 GLE, 1.6 TD, 1.8, 1.8 GTE	ch.81-F-150000→; ch.→8A-L-038757	<b>F8-5081</b>		d=20
Stabiliser Mounting	1.3, 1.6, 1.6 D, 1.6 GLE, 1.6 TD, 1.8, 1.8 GTE, 1.9 CD-5S, 2.0, 2.2		<b>F8-5225</b>		d=19
Suspension, panhard rod	1.3, 1.6, 1.6 D, 1.6 GLE, 1.6 TD, 1.8, 1.8 GTE		<b>F8-5344</b>		d=12.2
Engine Mounting	1.3, 1.6, 1.6 D, 1.6 GLE, 1.6 TD, 1.8, 1.9 CD-5S, 2.0		<b>F8-5685</b>		H=36; d=10; D=40.5
Top Strut Mounting	1.3, 1.6, 1.6 D, 1.6 GLE, 1.6 TD, 1.8, 1.8 GTE, 1.9 CD-5S, 2.0, 2.2		<b>F8-5905</b>		
Engine Mounting	1.6 D	JK;	<b>F8-6834</b>		
Engine Mounting	1.6, 1.6 GLE, 1.6 TD, 1.8		<b>F8-6834</b>		
Engine Mounting	1.8 GTE quattro	Green	<b>F8-6834</b>		
Engine Mounting	1.9 CD-5S, 2.0	ch.81-C-000001→	<b>F8-6925</b>		
Engine Mounting	2.0 quattro , 2.2 quattro		<b>F8-6925</b>		
Engine Mounting	2.2	ch.81-C-000001→; ch.→81-B-200000	<b>F8-6925</b>		
Bellow, steering	1.3, 1.6, 1.6 D, 1.6 GLE, 1.6 TD	ch.81-A0173589→; with clamps	<b>LM-10026S</b>		d1=27; d2=45; L [mm]=150
Bellow, steering	1.3, 1.6, 2.2 quattro	ch.81-A-173589→; with clamps	<b>LM-10026S</b>		d1=27; d2=45; L [mm]=150
Bellow, steering	1.6, 1.8, 1.8 CC quattro , 1.8 GTE, 1.8 GTE quattro , 1.9 CD-5S, 2.0, 2.0 quattro , 2.2, 2.2 quattro	with clamps	<b>LM-10026S</b>		d1=27; d2=45; L [mm]=150

**80 (89, 89Q, 8A, B3)****06/1986 → 10/1991**

Dust Cover Kit, shock absorber	1.6, 1.6 D, 1.6 TD, 1.8, 1.8 E, 1.8 E quattro, 1.8 quattro, 1.8 S, 1.8 S quattro, 1.9 D, 2.0, 2.0 E, 2.0 E 16V, 2.0 E 16V quattro, 2.0 E quattro, 2.0 quattro		<b>AK-735002</b>		
Dust Cover Kit, shock absorber	1.6, 1.6 D, 1.6 TD, 1.8, 1.8 E, 1.8 S, 1.9 D, 2.0, 2.0 E, 2.0 E 16V		<b>AK-735006</b>		
Dust Cover Kit, shock absorber	1.6, 1.6 D, 1.6 TD, 1.8, 1.8 E, 1.8 E quattro, 1.8 quattro, 1.8 S, 1.8 S quattro, 1.9 D, 2.0, 2.0 E, 2.0 E 16V, 2.0 E 16V quattro, 2.0 E quattro, 2.0 quattro		<b>AK-735027</b>		
Dust Cover Kit, shock absorber	1.4, 1.6, 1.6 D, 1.6 TD, 1.8, 1.8 E, 1.8 E quattro, 1.8 quattro, 1.8 S, 1.8 S quattro, 1.9 D, 2.0, 2.0 E, 2.0 E 16V, 2.0 E 16V quattro, 2.0 E quattro, 2.0 quattro		<b>AK-735098</b>		
Control Arm-/Trailing Arm Bush	1.6, 1.6 D, 1.6 TD, 1.8, 1.8 E, 1.8 S, 1.9 D, 2.0, 2.0 E, 2.0 E 16V		<b>F8-1026</b>		H=44; d=10; D1=38; D2=48
Control Arm-/Trailing Arm Bush	1.8 E quattro, 1.8 quattro, 1.8 S quattro, 2.0 E 16V quattro, 2.0 E quattro, 2.0 quattro		<b>F8-1026</b>		H=44; d=10; D1=38; D2=48
Top Strut Mounting	1.4, 1.6, 1.6 D, 1.6 TD, 1.8, 1.8 E, 1.8 E quattro, 1.8 quattro, 1.8 S, 1.8 S quattro, 1.9 D, 2.0, 2.0 E, 2.0 E 16V, 2.0 E 16V quattro, 2.0 E quattro, 2.0 quattro		<b>F8-1027</b>		H=37; d1=14; d2=20; D=76

<b>AK-735002</b>	<b>AK-735006</b>	<b>AK-735027</b>	<b>AK-735098</b>	<b>F8-1026</b>	<b>F8-1027</b>	<b>F8-4073</b>
Ref.Nr.:	Ref.Nr.:	Ref.Nr.:	Ref.Nr.:	Ref.Nr.: 811407181A	Ref.Nr.: 811412323D	Ref.Nr.: 811419831B
<b>F8-4080</b>	<b>F8-4085</b>	<b>F8-5081</b>	<b>F8-5225</b>	<b>F8-5344</b>	<b>F8-5685</b>	<b>F8-5905</b>
Ref.Nr.: 113501149	Ref.Nr.: 811512131	Ref.Nr.: 811411327A	Ref.Nr.: 823411327B	Ref.Nr.: 431505172	Ref.Nr.: 811199419A	Ref.Nr.: 8A0512333
<b>F8-6834</b>	<b>F8-6925</b>	<b>LM-10026S</b>				
Ref.Nr.: 823199381C	Ref.Nr.: 443199381J	Ref.Nr.: 811419831B				

Article Description



Article Nr.

Fitting Position



<b>80 (89, 89Q, 8A, B3)</b>				<b>06/1986 → 10/1991</b>	
Top Strut Mounting	2.0 quattro	ch.89-H-300001→; ch.→8A-N-200000; ☞	<b>F8-1027</b>		H=37; d1=14; d2=20; D=76
Mounting, axle beam	1.6, 1.6 D, 1.6 TD, 1.8, 1.8 E, 1.8 S, 1.9 D, 2.0, 2.0 E, 2.0 E 16V		<b>F8-1028</b>		H1=28; H2=38; d=12,2; D=41
Stabiliser Mounting	1.6, 1.6 D, 1.8, 1.8 E, 1.8 S, 2.0 E	☞	<b>F8-1029</b>		H=42; Thick. [mm]=25; W=38
Stabiliser Mounting	1.9 D	ch.→8A-L-028757; ☞	<b>F8-1029</b>		H=42; Thick. [mm]=25; W=38
Engine Mounting	1.6, 1.6 D, 1.6 TD, 1.8, 1.8 E, 1.8 E quattro, 1.8 quattro, 1.8 S, 1.8 S quattro, 1.9 D, 2.0, 2.0 E, 2.0 E 16V, 2.0 E 16V quattro, 2.0 E quattro, 2.0 quattro		<b>F8-1031</b>		H=47; d=10; D1=36; D2=52
Engine Mounting	1.6, 1.6 D, 1.6 TD, 1.8, 1.8 E, 1.8 S, 2.0 E	ch.→8C-P-053245	<b>F8-1032</b>		D=10; H=42; D1=38; D2=46
Engine Mounting	1.6, 1.8, 1.8 E, 1.8 S	☞	<b>F8-3000</b>		H=60; Thick. [mm]=66; W=89
Anti-Friction Bearing	1.4, 1.6, 1.6 D, 1.6 TD, 1.8, 1.8 E, 1.8 E quattro, 1.8 quattro, 1.8 S, 1.8 S quattro, 1.9 D, 2.0, 2.0 E, 2.0 E 16V, 2.0 E 16V quattro, 2.0 E quattro, 2.0 quattro		<b>F8-3036</b>		
Flange, carburettor	1.6, 1.8, 1.8 S, 1.8 S quattro		<b>F8-3045</b>		H=21
Flange, carburettor	1.6		<b>F8-3047</b>		H=24
Flange, carburettor	1.8 S		<b>F8-3048</b>		H=27; d=40
Mounting, radiator	1.6 D, 1.6 TD, 1.9 D, 2.0 E 16V quattro		<b>F8-4009</b>		H1=15; H2=37; D=39; Outer Thread [mm]=M8 x 1,50
Mounting, radiator	1.6, 1.8, 1.8 E quattro, 1.8 quattro, 1.8 S, 1.8 S quattro, 2.0 E quattro, 2.0 quattro	for hot climate zones	<b>F8-4009</b>		H1=15; H2=37; D=39; Outer Thread [mm]=M8 x 1,50
Mounting, radiator	1.8, 1.8 E, 1.8 S, 2.0, 2.0 E	for hot climate zones; ☞	<b>F8-4009</b>		H1=15; H2=37; D=39; Outer Thread [mm]=M8 x 1,50
Mounting, radiator	1.6, 1.8, 1.8 E, 1.8 E quattro, 1.8 quattro, 1.8 S, 1.8 S quattro, 2.0, 2.0 E, 2.0 E quattro, 2.0 quattro		<b>F8-4011</b>		H1=16; H2=38; D=30; Outer Thread [mm]=M8 x 1,25
Flange, carburettor	1.8, 1.8 S, 1.8 S quattro		<b>F8-4012</b>		H=20; L=146; W=112
Engine Mounting	1.6, 1.8, 1.8 E, 1.8 S, 2.0, 2.0 E, 2.0 E 16V		<b>F8-4019</b>		H=47; d=26; D1=48; D2=67
Rubber Buffer, engine mounting	1.6 TD	ch.8A-M-240001→; 01/1991 →	<b>F8-4020</b>		H=47; d=26; D1=47; D2=70
Rubber Buffer, engine mounting	1.9 D		<b>F8-4020</b>		H=47; d=26; D1=47; D2=70
Clamp, silencer	1.6, 1.6 D, 1.6 TD, 1.8, 1.8 E, 1.8 E quattro, 1.8 quattro, 1.8 S, 1.8 S quattro, 1.9 D, 2.0, 2.0 E, 2.0 E 16V, 2.0 E quattro, 2.0 quattro		<b>F8-4027</b>		H=17; W=53, 61
Mounting, automatic transmission	1.6 TD	ch.→8A-N-200000	<b>F8-4028</b>		H=42; D=11; D1=50; D2=80; τ [mm]=94
Mounting, automatic transmission	1.8 E quattro, 1.8 quattro, 1.8 S quattro, 1.9 D		<b>F8-4028</b>		H=42; D=11; D1=50; D2=80; τ [mm]=94
Mounting, automatic transmission	2.0 E 16V quattro	☞	<b>F8-4028</b>		H=42; D=11; D1=50; D2=80; τ [mm]=94
Mounting, automatic transmission	2.0 E quattro, 2.0 quattro	ch.89-H-300001→	<b>F8-4028</b>		H=42; D=11; D1=50; D2=80; τ [mm]=94

<b>F8-1027</b>	<b>F8-1028</b>	<b>F8-1029</b>	<b>F8-1031</b>	<b>F8-1032</b>	<b>F8-3000</b>	<b>F8-3036</b>
Ref.Nr.: 811412323D	Ref.Nr.: 811511247	Ref.Nr.: 823411313A	Ref.Nr.: 811199415A	Ref.Nr.: 811199419B	Ref.Nr.: 823199381B	Ref.Nr.: 377412335A
<b>F8-3045</b>	<b>F8-3047</b>	<b>F8-3048</b>	<b>F8-4009</b>	<b>F8-4011</b>	<b>F8-4012</b>	<b>F8-4019</b>
Ref.Nr.: 027129761	Ref.Nr.: 050129761C	Ref.Nr.: 050129761B	Ref.Nr.: 431121273	Ref.Nr.: 803121273	Ref.Nr.: 050129761D	Ref.Nr.: 893199339
<b>F8-4020</b>	<b>F8-4027</b>	<b>F8-4028</b>	<b>F8-4031</b>			
Ref.Nr.: 893199339D	Ref.Nr.: 171253147A	Ref.Nr.: 431399151D	Ref.Nr.: 893399151A			

**Article Description****Article Nr.****Fitting Position**

<b>80 (89, 89Q, 8A, B3)</b>		<b>06/1986 → 10/1991</b>	
Mounting, automatic transmission	1.6, 1.6 D, 1.6 TD, 1.8, 1.8 E, 1.8 E quattro, 1.8 quattro, 1.8 S, 1.8 S quattro, 1.9 D, 2.0, 2.0 E, 2.0 E 16V, 2.0 E 16V quattro, 2.0 E quattro, 2.0 quattro	<b>F8-4031</b>	⊕
Control Arm-/Trailing Arm Bush	1.6, 1.6 D, 1.6 TD, 1.8, 1.8 E, 1.8 quattro, 1.8 S, 1.9 D, 2.0, 2.0 E, 2.0 E 16V	<b>F8-4043</b>	⊕ ⊕ ⊕
Control Arm-/Trailing Arm Bush	1.8 E quattro, 1.8 S quattro, 2.0 E quattro	ch.8A-L-038657→; 01/1990 →	<b>F8-4043</b>
Control Arm-/Trailing Arm Bush	2.0 E 16V quattro, 2.0 quattro	ch.8A-L-038657→	<b>F8-4043</b>
Stabiliser Mounting	1.6, 1.6 D, 1.6 TD, 1.8, 1.8 E, 1.8 E quattro, 1.8 quattro, 1.8 S, 1.8 S quattro, 1.9 D, 2.0, 2.0 E, 2.0 E 16V, 2.0 E 16V quattro, 2.0 E quattro, 2.0 quattro	<b>F8-4059</b>	⊕
Rubber Buffer, suspension	1.6, 1.6 D, 1.6 TD, 1.8, 1.8 E, 1.8 E quattro, 1.8 quattro, 1.8 S, 1.8 S quattro, 1.9 D, 2.0, 2.0 E, 2.0 E 16V, 2.0 E 16V quattro, 2.0 E quattro, 2.0 quattro	<b>F8-4062</b>	⊕
Protective Cap/Bellow, shock absorber	1.6, 1.6 D, 1.6 TD, 1.8, 1.8 E, 1.8 E quattro, 1.8 quattro, 1.8 S, 1.8 S quattro, 1.9 D, 2.0, 2.0 E, 2.0 E 16V, 2.0 E 16V quattro, 2.0 quattro	<b>F8-4065</b>	⊕
Bellow, steering	1.6, 1.6 D, 1.6 TD, 1.8, 1.8 E, 1.8 E quattro, 1.8 quattro, 1.8 S, 1.8 S quattro, 1.9 D, 2.0, 2.0 E, 2.0 E 16V, 2.0 E 16V quattro, 2.0 E quattro, 2.0 quattro	<b>F8-4073</b>	⊕ ⊕
Bellow, driveshaft	1.8, 1.8 E, 1.8 quattro, 1.8 S, 1.8 S quattro, 1.9 D, 2.0, 2.0 E quattro	<b>F8-4080</b>	⊕ ⊕ ⊕
Rubber Buffer, suspension	1.6, 1.6 D, 1.6 TD, 1.8, 1.8 E, 1.8 S, 1.9 D, 2.0, 2.0 E		<b>F8-4086</b>
Stabiliser Mounting	1.6, 1.6 D, 1.6 TD, 1.8, 1.8 E, 1.8 S, 1.9 D, 2.0, 2.0 E, 2.0 E 16V	ch.81-F-150000→; ch.→8A-L-038757	<b>F8-5081</b>
Suspension, panhard rod	1.6, 1.6 TD, 1.8, 1.8 E, 1.8 S, 1.9 D, 2.0, 2.0 E, 2.0 E 16V	<b>F8-5344</b>	⊕ ⊕ ⊕
Rubber Buffer, engine mounting	1.6 D, 1.6 TD	ch.→8A-M-240000	<b>F8-5524</b>
Top Strut Mounting	1.4, 1.6, 1.6 D, 1.6 TD, 1.8, 1.8 E, 1.8 S, 1.9 D, 2.0, 2.0 E, 2.0 E 16V	<b>F8-5905</b>	⊕ ⊕ ⊕ ⊕ ↓
Engine Mounting	2.0, 2.0 E, 2.0 E 16V	<b>F8-6212</b>	⊕
Engine Mounting	1.6, 1.8, 1.8 S		<b>F8-6834</b>
Bellow, steering	All Models	with clamps	<b>LM-10026S</b>
<b>80 (8C, B4)</b>		<b>09/1991 → 12/1994</b>	
Dust Cover Kit, shock absorber	1.6, 1.6 E, 1.9 TD, 1.9 TDI, 2.0, 2.0 E, 2.0 E 16V, 2.0 E 16V quattro, 2.0 E quattro, 2.3 E, 2.3 E quattro, 2.6, 2.6 quattro, 2.8, 2.8 quattro, S2 quattro	<b>AK-735002</b>	⊕ ⊕ ⊕
Dust Cover Kit, shock absorber	1.6, 1.6 E, 1.9 TD, 1.9 TDI, 2.0, 2.0 E, 2.0 E 16V, 2.0 E 16V quattro, 2.0 E quattro, 2.3 E, 2.3 E quattro, 2.6, 2.6 quattro, 2.8, 2.8 quattro, S2 quattro	<b>AK-735006</b>	⊕ ⊕ ⊕

<b>AK-735002</b>	<b>AK-735006</b>	<b>AK-735027</b>	<b>F8-4031</b>	<b>F8-4043</b>	<b>F8-4059</b>	<b>F8-4062</b>
Ref.Nr.:	Ref.Nr.:	Ref.Nr.:	Ref.Nr.: 893399151A	Ref.Nr.: 8A0407181	Ref.Nr.: 893411327C	Ref.Nr.: 811412131A
<b>F8-4065</b>	<b>F8-4073</b>	<b>F8-4080</b>	<b>F8-4086</b>	<b>F8-5081</b>	<b>F8-5344</b>	<b>F8-5524</b>
Ref.Nr.: 811412135A	Ref.Nr.: 811419831B	Ref.Nr.: 113501149	Ref.Nr.: 893512131	Ref.Nr.: 811411327A	Ref.Nr.: 431505172	Ref.Nr.: 893199339A
<b>F8-5905</b>	<b>F8-6212</b>	<b>F8-6834</b>	<b>LM-10026S</b>			
Ref.Nr.: 8A0512333	Ref.Nr.: 893399151	Ref.Nr.: 823199381C	Ref.Nr.: 811419831B			

<b>Article Description</b>			<b>Article Nr.</b>	<b>Fitting Position</b>	
----------------------------	--	--	--------------------	-------------------------	--

<b>80 (8C, B4)</b>		<b>09/1991 → 12/1994</b>		
Dust Cover Kit, shock absorber	1.6, 1.6 E, 1.9 TD, 1.9 TDI, 2.0, 2.0 E, 2.0 E 16V, 2.0 E 16V quattro, 2.0 E quattro, 2.3 E, 2.3 E quattro, 2.6, 2.6 quattro, 2.8, 2.8 quattro		AK-735027	
Dust Cover Kit, shock absorber	1.6, 1.6 E, 1.9 TD, 1.9 TDI, 2.0, 2.0 E, 2.0 E 16V, 2.0 E 16V quattro, 2.0 E quattro, 2.3 E, 2.3 E quattro		AK-735098	
Control Arm-/Trailing Arm Bush	1.6, 1.9 TD, 1.9 TDI, 2.0, 2.0 E, 2.0 E 16V, 2.3 E, 2.6, 2.8		F8-1026	H=44; d=10; D1=38; D2=48
Top Strut Mounting	1.6, 1.6 E, 1.9 TD, 1.9 TDI, 2.0, 2.0 E, 2.0 E 16V, 2.0 E 16V quattro, 2.0 E quattro, 2.0 quattro, 2.3 E, 2.3 E quattro, 2.6, 2.6 quattro, 2.8, 2.8 quattro, S2 quattro		F8-1027	H=37; d1=14; d2=20; D=76
Engine Mounting	1.6, 1.9 TD, 1.9 TDI, 2.0, 2.0 E, 2.0 E 16V, 2.0 E 16V quattro, 2.0 E quattro, 2.3 E, 2.3 E quattro, 2.6, 2.6 quattro, 2.8, 2.8 quattro	ch.→8A-N-200000	F8-1031	H=47; d=10; D1=36; D2=52
Engine Mounting	1.6, 1.6 E, 1.9 TD, 1.9 TDI, 2.0, 2.0 E, 2.0 E 16V, 2.3 E, 2.6, 2.8	ch.→8C-P-053245	F8-1032	D=10; H=42; D1=38; D2=46
Anti-Friction Bearing	1.6, 1.6 E, 1.9 TD, 1.9 TDI, 2.0, 2.0 E, 2.0 E 16V, 2.0 E 16V quattro, 2.0 E quattro, 2.3 E, 2.3 E quattro, 2.6, 2.6 quattro, 2.8, 2.8 quattro, S2 quattro		F8-3036	
Flange, carburettor	1.6		F8-3047	H=24
Flange, carburettor	1.6	01/1994 →	F8-3048	H=27; d=40
Flange, carburettor	2.0		F8-3048	H=27; d=40
Mounting, axle beam	1.6, 1.6 E, 1.9 TD, 1.9 TDI, 2.0, 2.0 E, 2.0 E 16V, 2.3 E, 2.6, 2.8		F8-3052	H=90; d=12; D1=57; D2=70
Control Arm-/Trailing Arm Bush	2.8	ch.8C-N-000352→; ch.→8C-N-175591	F8-3057	H=44; d=10; D1=44; D2=54
Control Arm-/Trailing Arm Bush	S2 quattro		F8-3057	H=44; d=10; D1=44; D2=54
Mounting, radiator	2.3 E		F8-4009	H1=15; H2=37; D=39; Outer Thread [mm]=M8 x 1,50
Mounting, radiator	1.6, 1.6 E, 1.9 TD, 1.9 TDI, 2.0, 2.0 E, 2.0 E 16V, 2.0 E 16V quattro, 2.0 E quattro, 2.3 E, 2.3 E quattro, 2.6, 2.6 quattro, 2.8, 2.8 quattro		F8-4010	H1=15; H2=44; D=40
Mounting, radiator	1.6, 1.6 E, 2.0, 2.0 E, 2.0 E quattro, 2.3 E, 2.3 E quattro, S2 quattro		F8-4011	H1=16; H2=38; D=30; Outer Thread [mm]=M8 x 1,25
Engine Mounting	1.6, 1.6 E, 2.0, 2.0 E, 2.0 E 16V, 2.6, 2.6 quattro, 2.8, 2.8 quattro		F8-4019	H=47; d=26; D1=48; D2=67
Rubber Buffer, engine mounting	1.9 TD, 1.9 TDI		F8-4020	H=47; d=26; D1=47; D2=70
Clamp, silencer	1.6, 1.6 E, 1.9 TD, 1.9 TDI, 2.0, 2.0 E, 2.0 E 16V, 2.3 E, 2.6, 2.8		F8-4027	H=17; W=53, 61
Clamp, silencer	2.0 E 16V quattro, 2.0 E quattro, 2.3 E quattro, 2.6 quattro, 2.8 quattro, S2 quattro	ch.8C-R-118706→; 12/1993 →	F8-4027	H=17; W=53, 61
Mounting, automatic transmission	1.9 TD, 1.9 TDI, 2.0, 2.0 E, 2.0 E quattro		F8-4028	H=42; D=11; D1=50; D2=80; τ [mm]=94

<b>AK-735027</b>	<b>AK-735098</b>	<b>F8-1026</b>	<b>F8-1027</b>	<b>F8-1031</b>	<b>F8-1032</b>	<b>F8-3036</b>
Ref.Nr.:	Ref.Nr.:	Ref.Nr.: 811407181A	Ref.Nr.: 811412323D	Ref.Nr.: 811199415A	Ref.Nr.: 811199419B	Ref.Nr.: 377412335A
<b>F8-3047</b>	<b>F8-3048</b>	<b>F8-3052</b>	<b>F8-3057</b>	<b>F8-4009</b>	<b>F8-4010</b>	<b>F8-4011</b>
Ref.Nr.: 050129761C	Ref.Nr.: 050129761B	Ref.Nr.: 8A0501541	Ref.Nr.: 893407181	Ref.Nr.: 431121273	Ref.Nr.: 8A0121273	Ref.Nr.: 803121273
<b>F8-4019</b>	<b>F8-4020</b>	<b>F8-4027</b>	<b>F8-4028</b>			
Ref.Nr.: 893199339	Ref.Nr.: 893199339D	Ref.Nr.: 171253147A	Ref.Nr.: 431399151D			

**Article Description****Article Nr.****Fitting Position**

<b>80 (8C, B4)</b>				<b>09/1991 → 12/1994</b>	
Mounting, automatic transmission	2.0 E 16V quattro, 2.3 E quattro			<b>F8-4028</b>	H=42; D=11; D1=50; D2=80; $\tau$ [mm]=94
Control Arm-/Trailing Arm Bush	1.6, 1.6 E, 1.9 TD, 1.9 TDI, 2.0, 2.0 E, 2.0 E 16V, 2.0 E 16V quattro, 2.0 E quattro, 2.3 E, 2.3 E quattro, 2.6 quattro, 2.8 quattro, S2 quattro			<b>F8-4043</b>	H=44; d=10; D1=37; D2=54
Control Arm-/Trailing Arm Bush	2.6	ch.8C-N-175592→		<b>F8-4043</b>	H=44; d=10; D1=37; D2=54
Control Arm-/Trailing Arm Bush	2.8	ch.8C-N-175592→; 01/1992 →		<b>F8-4043</b>	H=44; d=10; D1=37; D2=54
Stabiliser Mounting	1.6, 1.6 E, 1.9 TD, 1.9 TDI, 2.0, 2.0 E, 2.0 E 16V, 2.0 E 16V quattro, 2.0 E quattro, 2.3 E, 2.3 E quattro, 2.6, 2.6 quattro, 2.8, 2.8 quattro, S2 quattro			<b>F8-4059</b>	H=30; d=22
Rubber Buffer, suspension	1.6, 1.6 E, 2.0, 2.0 E, 2.0 E quattro			<b>F8-4062</b>	H=67; d1=20; d2=24; D=52
Protective Cap/Bellow, shock absorber	1.6 E, 1.9 TD, 1.9 TDI, 2.0, 2.0 E 16V, 2.0 E 16V quattro, 2.0 E quattro, 2.3 E, 2.3 E quattro, 2.6, 2.6 quattro, 2.8, 2.8 quattro, S2 quattro			<b>F8-4065</b>	H=97; d1=46; d2=76
Bellow, steering	1.6, 1.6 E, 1.9 TD, 1.9 TDI, 2.0, 2.0 E, 2.0 E 16V, 2.0 E 16V quattro, 2.0 E quattro, 2.3 E, 2.3 E quattro, 2.6, 2.6 quattro, 2.8, 2.8 quattro, S2 quattro			<b>F8-4073</b>	H=147; D=48
Engine Mounting	1.6, 1.6 E, 2.0 E, 2.0 E 16V, 2.3 E	ch.8C-P-053246→		<b>F8-5527</b>	d=12; L=42; D=38
Engine Mounting	1.9 TD, 1.9 TDI, 2.0	ch.8C-P-053246→;		<b>F8-5527</b>	d=12; L=42; D=38
Engine Mounting	1.6 E, 2.0, 2.0 E, 2.0 E 16V, 2.0 E quattro	ch.8C-P-053246→		<b>F8-5528</b>	d=12; D=39; Thick. [mm]=46
Engine Mounting	1.6, 1.9 TDI	ch.8C-P-050246, 8C-P-053246→		<b>F8-5528</b>	d=12; D=39; Thick. [mm]=46
Engine Mounting	1.9 TD	ch.8B-P-009001, 8C-P-050246→		<b>F8-5528</b>	d=12; D=39; Thick. [mm]=46
Engine Mounting	2.0 E 16V quattro, 2.8	ch.8C-N-190001→		<b>F8-5528</b>	d=12; D=39; Thick. [mm]=46
Engine Mounting	2.3 E quattro, 2.6 quattro, S2 quattro	ch.8C-P-053246, 8C-P-244764→		<b>F8-5528</b>	d=12; D=39; Thick. [mm]=46
Engine Mounting	2.3 E, 2.6	ch.8C-N-190001, 8C-P-053246→		<b>F8-5528</b>	d=12; D=39; Thick. [mm]=46
Engine Mounting	2.8 quattro	ch.8C-N-190001, 8C-P-244764→		<b>F8-5528</b>	d=12; D=39; Thick. [mm]=46
Engine Mounting	1.6, 1.6 E, 1.9 TD, 1.9 TDI, 2.0, 2.0 E, 2.0 E 16V, 2.0 E 16V quattro, 2.0 E quattro, 2.0 quattro			<b>F8-5529</b>	
Mounting, axle beam	2.0 E 16V quattro, 2.0 E quattro, 2.0 quattro, 2.3 E quattro, 2.6 quattro, 2.8 quattro, S2 quattro			<b>F8-5541</b>	d=12; D=58; W=35.8, 58
Belt Pulley, crankshaft	1.9 TD, 1.9 TDI	ch.8C-N-000001→; Number of Ribs: 5; Parameter: 6PK		<b>F8-5649</b>	H=31.5; d=30.02; Mounting points diam.[mm]=8.5; D1=161.5; D2=160.5
Top Strut Mounting	1.6, 1.6 E, 1.9 TD, 1.9 TDI, 2.0, 2.0 E, 2.0 E 16V, 2.3 E, 2.6, 2.8			<b>F8-5904</b>	
Top Strut Mounting	1.6, 1.6 E, 1.9 TD, 1.9 TDI, 2.0, 2.0 E, 2.0 E 16V, 2.3 E, 2.6, 2.8			<b>F8-5905</b>	
Repair Kit, suspension strut	1.6, 1.6 E, 1.9 TD, 1.9 TDI, 2.0, 2.0 E, 2.0 E 16V, 2.3 E, 2.6, 2.8			<b>F8-5906</b>	
Engine Mounting	1.9 TD, 1.9 TDI, 2.0	ch.8C-P-053246→		<b>F8-5934</b>	



Article Description



Article Nr.

Fitting Position



<b>80 (8C, B4)</b>			<b>09/1991 → 12/1994</b>		
Engine Mounting	2.6, 2.6 quattro, 2.8, 2.8 quattro		<b>F8-5934</b>		
Engine Mounting	2.0, 2.0 E, 2.0 E 16V, 2.3 E, 2.6		<b>F8-6212</b>		
Engine Mounting	1.6, 1.6 E, 1.9 TD, 1.9 TDI, 2.0, 2.0 E, 2.0 E 16V, 2.0 E 16V quattro, 2.0 E quattro, 2.0 quattro		<b>F8-6241</b>		
Engine Mounting	2.3 E	Blue;	<b>F8-6748</b>		
Engine Mounting	2.3 E	ch.8C-N-000001→; Green;	<b>F8-6749</b>		
Engine Mounting	2.3 E quattro, S2 quattro	ch.8C-N-000001→; Green;	<b>F8-6749</b>		
Engine Mounting	2.3 E, 2.3 E quattro, S2 quattro	ch.8C-N-000001→; Brown;	<b>F8-6750</b>		
Engine Mounting	2.3 E, 2.3 E quattro, S2 quattro	ch.8C-N-000001→; White;	<b>F8-6751</b>		
Control Arm-/Trailing Arm Bush	2.0 E 16V quattro, 2.0 E quattro, 2.3 E quattro, 2.6 quattro, 2.8 quattro, S2 quattro	for OE: 8A0505323A, 8A0505323B, 8A0505324B, 8D0505323A, 8D0505323B, 8D0505324B	<b>F8-7149</b>		
Control Arm-/Trailing Arm Bush	2.0 E 16V quattro, 2.0 E quattro, 2.0 quattro, 2.3 E quattro, 2.6 quattro, 2.8 quattro, S2 quattro		<b>F8-7921</b>		d=12
Engine Mounting	1.6, 1.6 E, 1.9 TD, 1.9 TDI, 2.0, 2.0 E, 2.0 E 16V		<b>F8-8180</b>		
Engine Mounting	2.0 E 16V quattro, 2.0 E quattro		<b>F8-8180</b>		
Bellow, steering	All Models	with clamps	<b>LM-10026S</b>		d1=27; d2=45; L [mm]=150
<b>80 Avant (8C, B4)</b>			<b>09/1991 → 01/1996</b>		
Dust Cover Kit, shock absorber	1.6 E, 1.9 TDI, 2.0, 2.0 E, 2.0 E 16V, 2.0 E 16V quattro, 2.3 E, 2.3 E quattro, 2.6, 2.6 quattro, 2.8, 2.8 quattro, RS2 quattro, S2 quattro		<b>AK-735002</b>		
Dust Cover Kit, shock absorber	1.9 TDI, 2.0, 2.0 E, 2.0 E 16V, 2.0 E 16V quattro, 2.3 E, 2.3 E quattro, 2.6, 2.8, 2.8 quattro, S2 quattro		<b>AK-735006</b>		
Dust Cover Kit, shock absorber	1.6 E, 1.9 TDI, 2.0, 2.0 E, 2.0 E 16V, 2.0 E 16V quattro, 2.3 E, 2.3 E quattro, 2.6, 2.6 quattro, 2.8, 2.8 quattro		<b>AK-735027</b>		
Dust Cover Kit, shock absorber	1.6 E, 1.9 TD, 1.9 TDI, 2.0, 2.0 E, 2.0 E 16V, 2.0 E 16V quattro, 2.3 E, 2.3 E quattro		<b>AK-735098</b>		
Top Strut Mounting	All Models		<b>F8-1027</b>		H=37; d1=14; d2=20; D=76
Engine Mounting	1.6 E, 1.9 TDI, 2.0, 2.0 E, 2.0 E 16V, 2.3 E, 2.6, 2.8	ch.→8C-P-053245	<b>F8-1032</b>		D=10; H=42; D1=38; D2=46
Anti-Friction Bearing	1.6 E, 1.9 TD, 1.9 TDI, 2.0, 2.0 E, 2.0 E 16V, 2.0 E 16V quattro, 2.3 E, 2.3 E quattro, 2.6, 2.6 quattro, 2.8, 2.8 quattro, RS2 quattro, S2 quattro		<b>F8-3036</b>		
Flange, carburettor	2.0		<b>F8-3048</b>		H=27; d=40
Mounting, axle beam	1.6 E, 1.9 TDI, 2.0, 2.0 E, 2.0 E 16V, 2.3 E, 2.6, 2.8		<b>F8-3052</b>		H=90; d=12; D1=57; D2=70
Control Arm-/Trailing Arm Bush	2.8	ch.8C-N-000352→; ch.→8C-N-175591	<b>F8-3057</b>		H=44; d=10; D1=44; D2=54
Control Arm-/Trailing Arm Bush	S2 quattro		<b>F8-3057</b>		H=44; d=10; D1=44; D2=54
Mounting, radiator	2.0, 2.0 E, 2.3 E, 2.3 E quattro, 2.8, S2 quattro		<b>F8-4011</b>		H1=16; H2=38; D=30; Outer Thread [mm]=M8 x 1,25





**Article Description****Article Nr.****Fitting Position**

<b>80 Avant (8C, B4)</b>				<b>09/1991 → 01/1996</b>	
Engine Mounting	1.6 E, 2.0, 2.0 E, 2.0 E 16V, 2.6, 2.6 quattro, 2.8, 2.8 quattro		<b>F8-4019</b>		H=47; d=26; D1=48; D2=67
Rubber Buffer, engine mounting	1.9 TDI		<b>F8-4020</b>		H=47; d=26; D1=47; D2=70
Clamp, silencer	1.6 E, 1.9 TDI, 2.0, 2.0 E, 2.0 E 16V, 2.3 E, 2.6, 2.8, RS2 quattro		<b>F8-4027</b>		H=17; W=53, 61
Clamp, silencer	2.0 E 16V quattro, 2.3 E quattro, 2.6 quattro, 2.8 quattro, S2 quattro	ch.8C-R-118706→; 12/1993 →	<b>F8-4027</b>		H=17; W=53, 61
Mounting, automatic transmission	1.9 TDI		<b>F8-4028</b>		H=42; D=11; D1=50; D2=80; T [mm]=94
Mounting, automatic transmission	2.0, 2.0 E, 2.0 E 16V, 2.0 E 16V quattro, 2.3 E, 2.3 E quattro		<b>F8-4028</b>		H=42; D=11; D1=50; D2=80; T [mm]=94
Control Arm-/Trailing Arm Bush	1.6 E, 1.9 TDI, 2.0, 2.0 E, 2.0 E 16V, 2.0 E 16V quattro, 2.3 E, 2.3 E quattro, 2.6 quattro, 2.8 quattro, S2 quattro		<b>F8-4043</b>	⊕ ⊕	H=44; d=10; D1=37; D2=54
Control Arm-/Trailing Arm Bush	2.6	ch.8C-N-175592→	<b>F8-4043</b>	⊕ ⊕	H=44; d=10; D1=37; D2=54
Control Arm-/Trailing Arm Bush	2.8	ch.8C-N-175592→; 01/1992 →	<b>F8-4043</b>	⊕ ⊕	H=44; d=10; D1=37; D2=54
Stabiliser Mounting	1.6 E, 1.9 TDI, 2.0, 2.0 E, 2.0 E 16V, 2.0 E 16V quattro, 2.3 E, 2.3 E quattro, 2.6, 2.6 quattro, 2.8, 2.8 quattro, RS2 quattro, S2 quattro		<b>F8-4059</b>		H=30; d=22
Protective Cap/Bellow, shock absorber	1.6 E, 1.9 TDI, 2.0 E, 2.3 E		<b>F8-4065</b>		H=97; d1=46; d2=76
Bellow, steering	1.6 E, 1.9 TD, 1.9 TDI, 2.0, 2.0 E, 2.0 E 16V, 2.0 E 16V quattro, 2.3 E, 2.3 E quattro, 2.6, 2.6 quattro, 2.8, 2.8 quattro, RS2 quattro, S2 quattro		<b>F8-4073</b>	⊕ ⊕	H=147; D=48
Engine Mounting	1.6 E, 2.0 E, 2.0 E 16V, 2.3 E	ch.8C-P-053246→	<b>F8-5527</b>	⊕ ⊕	d=12; L=42; D=38
Engine Mounting	1.9 TDI, 2.0	ch.8C-P-053246→;	<b>F8-5527</b>	⊕ ⊕	d=12; L=42; D=38
Engine Mounting	1.6 E, 2.0, 2.0 E 16V quattro	ch.8C-P-053246→	<b>F8-5528</b>	⊕ ⊕	d=12; D=39; Thick. [mm]=46
Engine Mounting	1.9 TDI	ch.8C-P-050246, 8G-P-001001→	<b>F8-5528</b>	⊕ ⊕	d=12; D=39; Thick. [mm]=46
Engine Mounting	2.0 E, 2.0 E 16V, 2.3 E, 2.6 quattro, 2.8 quattro, S2 quattro	ch.8C-P-053246, 8C-P-244764→	<b>F8-5528</b>	⊕ ⊕	d=12; D=39; Thick. [mm]=46
Engine Mounting	2.3 E quattro	ch.8C-P-244764→	<b>F8-5528</b>	⊕ ⊕	d=12; D=39; Thick. [mm]=46
Engine Mounting	2.6, RS2 quattro	ch.8C-N-190001, 8C-P-244764→	<b>F8-5528</b>	⊕ ⊕	d=12; D=39; Thick. [mm]=46
Engine Mounting	2.8	ch.8C-N-190001→	<b>F8-5528</b>	⊕ ⊕	d=12; D=39; Thick. [mm]=46
Engine Mounting	1.6 E, 1.9 TD, 1.9 TDI, 2.0, 2.0 E, 2.0 E 16V, 2.0 E 16V quattro, 2.0 quattro		<b>F8-5529</b>	⊕	
Mounting, axle beam	2.0 E 16V quattro, 2.0 quattro, 2.3 E quattro, 2.6 quattro, 2.8 quattro, S2 quattro		<b>F8-5541</b>	⊕ ⊕ ⊕ ↓	d=12; D=58; W=35.8, 58
Belt Pulley, crankshaft	1.9 TD, 1.9 TDI	ch.8C-N-000001→; Number of Ribs: 5; Parameter: 6PK	<b>F8-5649</b>		H=31.5; d=30.02; Mounting points diam.[mm]=8.5; D1=161.5; D2=160.5

<b>F8-4019</b>	<b>F8-4020</b>	<b>F8-4027</b>	<b>F8-4028</b>	<b>F8-4043</b>	<b>F8-4059</b>	<b>F8-4065</b>
Ref.Nr.: 893199339	Ref.Nr.: 893199339D	Ref.Nr.: 171253147A	Ref.Nr.: 431399151D	Ref.Nr.: 8A0407181	Ref.Nr.: 893411327C	Ref.Nr.: 811412135A
<b>F8-4073</b>	<b>F8-5527</b>	<b>F8-5528</b>	<b>F8-5529</b>	<b>F8-5541</b>	<b>F8-5649</b>	<b>F8-5904</b>
Ref.Nr.: 811419831B	Ref.Nr.: 8A0199419	Ref.Nr.: 8A0199415C	Ref.Nr.: 8A0199379E	Ref.Nr.: 4D0511523C	Ref.Nr.: 028105243T	Ref.Nr.: 8A0512335

Article Description



Article Nr.

Fitting Position



**80 Avant (8C, B4)**

09/1991 → 01/1996

Top Strut Mounting	1.6 E, 1.9 TD, 1.9 TDI, 2.0, 2.0 E, 2.0 E 16V, 2.3 E, 2.6, 2.8		F8-5904		
Top Strut Mounting	1.6 E, 1.9 TD, 1.9 TDI, 2.0, 2.0 E, 2.0 E 16V, 2.3 E, 2.6, 2.8		F8-5905		
Repair Kit, suspension strut	1.6 E, 1.9 TD, 1.9 TDI, 2.0, 2.0 E, 2.0 E 16V, 2.3 E, 2.6, 2.8		F8-5906		
Engine Mounting	1.9 TD, 1.9 TDI, 2.0	ch.8C-P-053246→	F8-5934		
Engine Mounting	2.6, 2.6 quattro, 2.8, 2.8 quattro		F8-5934		
Engine Mounting	2.0, 2.0 E, 2.0 E 16V, 2.3 E, 2.6		F8-6212		
Engine Mounting	1.6 E, 1.9 TD, 1.9 TDI, 2.0, 2.0 E, 2.0 E 16V, 2.0 E 16V quattro, 2.0 quattro		F8-6241		
Engine Mounting	2.3 E	Blue;	F8-6748		
Engine Mounting	2.3 E	ch.8C-N-000001→; Green;	F8-6749		
Engine Mounting	2.3 E quattro, S2 quattro	ch.8C-N-000001→; Green;	F8-6749		
Engine Mounting	RS2 quattro	Green;	F8-6749		
Engine Mounting	2.3 E, 2.3 E quattro, S2 quattro	ch.8C-N-000001→; Brown;	F8-6750		
Engine Mounting	RS2 quattro	Brown;	F8-6750		
Engine Mounting	2.3 E, 2.3 E quattro, S2 quattro	ch.8C-N-000001→; White;	F8-6751		
Engine Mounting	RS2 quattro	White;	F8-6751		
Control Arm-/Trailing Arm Bush	2.0 E 16V quattro, 2.3 E quattro, 2.6 quattro, 2.8 quattro, RS2 quattro, S2 quattro	for OE: 8A0505323A, 8A0505323B, 8A0505324B, 8D0505323A, 8D0505323B, 8D0505324B	F8-7149		
Control Arm-/Trailing Arm Bush	2.0 E 16V quattro, 2.0 quattro, 2.3 E quattro, 2.6 quattro, 2.8 quattro, RS2 quattro, S2 quattro		F8-7921		d=12
Engine Mounting	1.6 E, 1.9 TDI, 2.0, 2.0 E, 2.0 E 16V		F8-8180		
Engine Mounting	2.0 E 16V quattro		F8-8180		
Bellow, steering	All Models	with clamps	LM-10026S		d1=27; d2=45; L [mm]=150

**90 (81, 85, B2)**

08/1984 → 03/1987

Dust Cover Kit, shock absorber	1.6 TD, 2.0, 2.2, 2.2 E quattro		AK-735002		
Dust Cover Kit, shock absorber	2.0, 2.2		AK-735006		
Dust Cover Kit, shock absorber	1.6 TD, 2.0, 2.2, 2.2 E quattro		AK-735027		
Dust Cover Kit, shock absorber	1.6 TD, 2.0, 2.2, 2.2 E quattro		AK-735098		
Engine Mounting	2.0	01/1985 →;	F8-1020		H=97; D=114; T [mm]=145
Engine Mounting	2.0, 2.2		F8-1020		H=97; D=114; T [mm]=145
Engine Mounting	2.0, 2.2		F8-1020		H=97; D=114; T [mm]=145
Engine Mounting	2.0, 2.2		F8-1020		H=97; D=114; T [mm]=145
Engine Mounting	2.2		F8-1020		H=97; D=114; T [mm]=145
Engine Mounting	2.2 E quattro		F8-1020		H=97; D=114; T [mm]=145

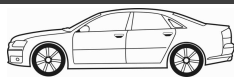

**Article Description****Article Nr.****Fitting Position**

<b>90 (81, 85, B2)</b>			<b>08/1984 → 03/1987</b>		
Engine Mounting	2.0, 2.2	01/1985 →;	<b>F8-1021</b>		H=97; D=114; $\tau$ [mm]=143
Engine Mounting	2.0, 2.2		<b>F8-1021</b>		H=97; D=114; $\tau$ [mm]=143
Engine Mounting	2.2 E quattro		<b>F8-1021</b>		H=97; D=114; $\tau$ [mm]=143
Control Arm-/Trailing Arm Bush	2.0, 2.2	ch.81-D-077974 →;	<b>F8-1026</b>		H=44; d=10; D1=38; D2=48
Top Strut Mounting	All Models		<b>F8-1027</b>		H=37; d1=14; d2=20; D=76
Mounting, axle beam	2.0, 2.2		<b>F8-1028</b>		H1=28; H2=38; d=12,2; D=41
Engine Mounting	2.0, 2.2	ch. → 8C-P-053245	<b>F8-1032</b>		D=10; H=42; D1=38; D2=46
Anti-Friction Bearing	1.6 TD, 2.0, 2.2, 2.2 E quattro		<b>F8-3036</b>		
Mounting, radiator	1.6 TD	ch. → 81-F-045000	<b>F8-4009</b>		H1=15; H2=37; D=39; Outer Thread [mm]=M8 x 1,50
Mounting, radiator	1.6 TD	ch.81-F-045001 →; ch. → 81-H-299999; for hot climate zones	<b>F8-4009</b>		H1=15; H2=37; D=39; Outer Thread [mm]=M8 x 1,50
Mounting, radiator	2.0, 2.0 quattro, 2.2, 2.2 E quattro		<b>F8-4009</b>		H1=15; H2=37; D=39; Outer Thread [mm]=M8 x 1,50
Mounting, radiator	1.6 TD, 2.0, 2.2, 2.2 E quattro		<b>F8-4011</b>		H1=16; H2=38; D=30; Outer Thread [mm]=M8 x 1,25
Clamp, silencer	2.2 E quattro		<b>F8-4027</b>		H=17; W=53, 61
Mounting, automatic transmission	2.0	ch. → 81-H-299999;	<b>F8-4028</b>		H=42; D=11; D1=50; D2=80; $\tau$ [mm]=94
Mounting, automatic transmission	2.0, 2.2	ch. → 81-H-299999;	<b>F8-4028</b>		H=42; D=11; D1=50; D2=80; $\tau$ [mm]=94
Mounting, automatic transmission	2.2, 2.2 E quattro		<b>F8-4028</b>		H=42; D=11; D1=50; D2=80; $\tau$ [mm]=94
Control Arm-/Trailing Arm Bush	2.0, 2.2, 2.2 E quattro		<b>F8-4043</b>		H=44; d=10; D1=37; D2=54
Rubber Buffer, suspension	1.6 TD, 2.0, 2.2, 2.2 E quattro		<b>F8-4062</b>		H=67; d1=20; d2=24; D=52
Protective Cap/Bellow, shock absorber	1.6 TD, 2.0, 2.2, 2.2 E quattro		<b>F8-4065</b>		H=97; d1=46; d2=76
Protective Cap/Bellow, shock absorber	1.6 TD, 2.0, 2.2, 2.2 E quattro		<b>F8-4065</b>		H=97; d1=46; d2=76
Bellow, steering	1.6 TD, 2.0, 2.2, 2.2 E quattro		<b>F8-4073</b>		H=147; D=48
Rubber Buffer, suspension	1.6 TD, 2.0, 2.2		<b>F8-4085</b>		H=84; d1=11; d2=15; D1=35; D2=48
Stabiliser Mounting	2.0, 2.2	ch.81-F-150000 →; ch. → 8A-L-038757	<b>F8-5081</b>		d=20
Suspension, panhard rod	2.0, 2.2		<b>F8-5344</b>		d=12,2
Engine Mounting	2.0, 2.2		<b>F8-5685</b>		H=36; d=10; D=40,5
Engine Mounting	2.2 E quattro	ch. → 81-H-299000, 85-H-299000	<b>F8-6925</b>		
Bellow, steering	All Models	with clamps	<b>LM-10026S</b>		d1=27; d2=45; L [mm]=150

<b>AK-735002</b>	<b>F8-1021</b>	<b>F8-1026</b>	<b>F8-1027</b>	<b>F8-1028</b>	<b>F8-1032</b>	<b>F8-3036</b>
Ref.Nr.:	Ref.Nr.: 443199382	Ref.Nr.: 811407181A	Ref.Nr.: 811412323D	Ref.Nr.: 811511247	Ref.Nr.: 811199419B	Ref.Nr.: 377412335A
<b>F8-4009</b>	<b>F8-4011</b>	<b>F8-4027</b>	<b>F8-4028</b>	<b>F8-4043</b>	<b>F8-4062</b>	<b>F8-4065</b>
Ref.Nr.: 431121273	Ref.Nr.: 803121273	Ref.Nr.: 171253147A	Ref.Nr.: 431399151D	Ref.Nr.: 8A0407181	Ref.Nr.: 811412131A	Ref.Nr.: 811412135A
<b>F8-4073</b>	<b>F8-4085</b>	<b>F8-5081</b>	<b>F8-5344</b>	<b>F8-5685</b>	<b>F8-6925</b>	<b>LM-10026S</b>
Ref.Nr.: 811419831B	Ref.Nr.: 811512131	Ref.Nr.: 811411327A	Ref.Nr.: 431505172	Ref.Nr.: 811199419A	Ref.Nr.: 443199381J	Ref.Nr.: 811419831B

Article Description			Article Nr.	Fitting Position	
---------------------	--	--	-------------	------------------	--

90 (89, 89Q, 8A, B3)			04/1987 → 09/1991		
Dust Cover Kit, shock absorber	1.6 TD, 2.0, 2.0 20 V, 2.0 20 V quattro, 2.2 E, 2.2 E quattro, 2.3 E, 2.3 E 20V, 2.3 E 20V quattro, 2.3 E quattro		AK-735002		
Dust Cover Kit, shock absorber	2.0, 2.2 E, 2.3 E, 2.3 E 20V		AK-735006		
Dust Cover Kit, shock absorber	1.6 TD, 2.0, 2.0 20 V, 2.0 20 V quattro, 2.2 E, 2.2 E quattro, 2.3 E, 2.3 E 20V, 2.3 E 20V quattro, 2.3 E quattro		AK-735027		
Dust Cover Kit, shock absorber	1.6 TD, 2.0, 2.0 20 V, 2.0 20 V quattro, 2.2 E, 2.2 E quattro, 2.3 E, 2.3 E 20V, 2.3 E 20V quattro, 2.3 E quattro		AK-735098		
Engine Mounting	2.0, 2.2 E, 2.2 E quattro, 2.3 E, 2.3 E 20V, 2.3 E 20V quattro, 2.3 E quattro		F8-1020		H=97; D=114; T [mm]=145
Engine Mounting	2.2 E quattro, 2.3 E 20V quattro, 2.3 E quattro		F8-1021		H=97; D=114; T [mm]=143
Top Strut Mounting	All Models		F8-1027		H=37; d1=14; d2=20; D=76
Mounting, axle beam	2.0, 2.2 E, 2.3 E, 2.3 E 20V		F8-1028		H1=28; H2=38; d=12.2; D=41
Engine Mounting	2.0, 2.2 E, 2.3 E, 2.3 E 20V	ch.→8C-P-053245	F8-1032		D=10; H=42; D1=38; D2=46
Anti-Friction Bearing	1.6 TD, 2.0, 2.0 20 V, 2.0 20 V quattro, 2.2 E, 2.2 E quattro, 2.3 E, 2.3 E 20V, 2.3 E 20V quattro, 2.3 E quattro		F8-3036		
Control Arm-/Trailing Arm Bush	2.3 E 20V		F8-3057		H=44; d=10; D1=44; D2=54
Control Arm-/Trailing Arm Bush	2.3 E 20V quattro	ch.89-J-373599→	F8-3057		H=44; d=10; D1=44; D2=54
Mounting, radiator	1.6 TD, 2.0 20 V quattro, 2.0 quattro, 2.2 E quattro, 2.3 E 20V quattro, 2.3 E quattro		F8-4009		H1=15; H2=37; D=39; Outer Thread [mm]=M8 x 1,50
Mounting, radiator	2.0, 2.0 20 V, 2.2 E, 2.3 E, 2.3 E 20V	ch.→8A-L-320000	F8-4009		H1=15; H2=37; D=39; Outer Thread [mm]=M8 x 1,50
Mounting, radiator	2.0, 2.0 20 V, 2.2 E, 2.3 E, 2.3 E 20V	ch.8A-L-320001→;  4-speed	F8-4009		H1=15; H2=37; D=39; Outer Thread [mm]=M8 x 1,50
Mounting, radiator	2.0, 2.2 E, 2.2 E quattro, 2.3 E, 2.3 E 20V, 2.3 E 20V quattro, 2.3 E quattro		F8-4011		H1=16; H2=38; D=30; Outer Thread [mm]=M8 x 1,25
Engine Mounting	2.0, 2.2 E, 2.2 E quattro, 2.3 E, 2.3 E 20V, 2.3 E 20V quattro, 2.3 E quattro	;	F8-4021		H=96; D=114; T [mm]=146
Clamp, silencer	1.6 TD, 2.0, 2.0 20 V, 2.2 E, 2.2 E quattro, 2.3 E, 2.3 E 20V, 2.3 E 20V quattro, 2.3 E quattro		F8-4027		H=17; W=53, 61
Mounting, automatic transmission	2.2 E, 2.2 E quattro, 2.3 E, 2.3 E 20V, 2.3 E 20V quattro, 2.3 E quattro		F8-4028		H=42; D=11; D1=50; D2=80; T [mm]=94
Mounting, automatic transmission	2.3 E	;	F8-4028		H=42; D=11; D1=50; D2=80; T [mm]=94
Control Arm-/Trailing Arm Bush	2.0, 2.2 E, 2.3 E, 2.3 E 20V		F8-4043		H=44; d=10; D1=37; D2=54
Control Arm-/Trailing Arm Bush	2.2 E quattro, 2.3 E quattro	ch.8A-L-038657→; 01/1990 →	F8-4043		H=44; d=10; D1=37; D2=54

<b>AK-735002</b>	<b>AK-735006</b>	<b>AK-735027</b>	<b>AK-735098</b>	<b>F8-1020</b>	<b>F8-1021</b>	<b>F8-1027</b>
Ref.Nr.:	Ref.Nr.:	Ref.Nr.:	Ref.Nr.:	Ref.Nr.: 443199379	Ref.Nr.: 443199382	Ref.Nr.: 811412323D
<b>F8-1028</b>	<b>F8-1032</b>	<b>F8-3036</b>	<b>F8-3057</b>	<b>F8-4009</b>	<b>F8-4011</b>	<b>F8-4021</b>
Ref.Nr.: 811511247	Ref.Nr.: 811199419B	Ref.Nr.: 377412335A	Ref.Nr.: 893407181	Ref.Nr.: 431121273	Ref.Nr.: 803121273	Ref.Nr.: 443199379E
<b>F8-4027</b>	<b>F8-4028</b>	<b>F8-4043</b>				
Ref.Nr.: 171253147A	Ref.Nr.: 431399151D	Ref.Nr.: 8A0407181				

**Article Description****Article Nr.****Fitting Position**

<b>90 (89, 89Q, 8A, B3)</b>			<b>04/1987 → 09/1991</b>		
Control Arm-/Trailing Arm Bush	2.3 E quattro	ch.89-J-351001→; 04/1990 →	<b>F8-4043</b>		H=44; d=10; D1=37; D2=54
Rubber Buffer, suspension	1.6 TD, 2.0, 2.0 20 V, 2.2 E, 2.2 E quattro, 2.3 E, 2.3 E 20V, 2.3 E 20V quattro, 2.3 E quattro		<b>F8-4062</b>		H=67; d1=20; d2=24; D=52
Protective Cap/Bellow, shock absorber	1.6 TD, 2.0, 2.2 E, 2.2 E quattro, 2.3 E, 2.3 E 20V, 2.3 E 20V quattro, 2.3 E quattro		<b>F8-4065</b>		H=97; d1=46; d2=76
Bellow, steering	1.6 TD, 2.0, 2.0 20 V, 2.2 E, 2.2 E quattro, 2.3 E, 2.3 E 20V, 2.3 E 20V quattro, 2.3 E quattro		<b>F8-4073</b>		H=147; D=48
Rubber Buffer, suspension	2.0, 2.2 E, 2.3 E		<b>F8-4086</b>		H=90; d1=9; d2=21; D1=67; D2=59
Stabiliser Mounting	2.0, 2.2 E, 2.3 E, 2.3 E 20V	ch.81-F-150000→; ch.→8A-L-038757	<b>F8-5081</b>		d=20
Suspension, panhard rod	2.0, 2.2 E, 2.3 E, 2.3 E 20V		<b>F8-5344</b>		d=12.2
Rubber Buffer, engine mounting	1.6 TD	ch.→8A-M-240000	<b>F8-5524</b>		d=26; L=47; D=68
Bellow, steering	All Models	with clamps	<b>LM-10026S</b>		d1=27; d2=45; L [mm]=150
<b>100 (43, C2)</b>			<b>06/1976 → 07/1982</b>		
Dust Cover Kit, shock absorber	All Models		<b>AK-735013</b>		
Control Arm-/Trailing Arm Bush	1.6, 1.9, 2.0 D, 2.1	ch.43-C-007001→	<b>F8-1017</b>		H=23; d=16; D=58
Control Arm-/Trailing Arm Bush	2.0		<b>F8-1017</b>		H=23; d=16; D=58
Control Arm-/Trailing Arm Bush	All Models		<b>F8-1018</b>		H1=31; H2=58; d=12; D1=21; D2=46
Mounting, axle beam	1.6, 1.9, 2.0 D, 2.1	ch.4392127796→	<b>F8-1019</b>		H1=33; H2=43; d=12; D=56
Engine Mounting	1.9, 2.1	01/1982 →	<b>F8-1020</b>		H=97; D=114; T [mm]=145
Mounting, axle bracket	2.0, 2.0 D, 2.1		<b>F8-1022</b>		H=57; d=12; D1=46; D2=62
Top Strut Mounting	1.6, 2.0 D, 2.1	01/1980 →;	<b>F8-1023</b>		H=26; d=17; D=58
Top Strut Mounting	1.9, 2.0		<b>F8-1023</b>		H=26; d=17; D=58
Mounting, axle bracket	1.6		<b>F8-3001</b>		H=52; d=12; D1=51; D2=69
Mounting, axle bracket	1.9, 2.0, 2.0 D, 2.1		<b>F8-3002</b>		H=51; d=12; D1=53; D2=67
Anti-Friction Bearing	All Models		<b>F8-3007</b>		H=15; d=81; D=102
Flange, carburettor	1.6	01/1978 →; Engine119264→	<b>F8-3046</b>		H=23
Flange, carburettor	2.1		<b>F8-3046</b>		H=23
Mounting, radiator	1.9, 2.0 D, 2.1		<b>F8-4009</b>		H1=15; H2=37; D=39; Outer Thread [mm]=M8 x 1,50
Engine Mounting	1.9		<b>F8-4021</b>		H=96; D=114; T [mm]=146
Engine Mounting	2.1	Engine054200→	<b>F8-4021</b>		H=96; D=114; T [mm]=146
Engine Mounting	2.1	Engine081137→	<b>F8-4021</b>		H=96; D=114; T [mm]=146
Rubber Buffer, silencer	2.0 D, 2.1		<b>F8-4026</b>		H=12; W=57, 60

<b>AK-735013</b>	<b>F8-1017</b>	<b>F8-1018</b>	<b>F8-1019</b>	<b>F8-1020</b>	<b>F8-1022</b>	<b>F8-1023</b>
Ref.Nr.:	Ref.Nr.: 431407181F	Ref.Nr.: 431407183A	Ref.Nr.: 431511247C	Ref.Nr.: 443199379	Ref.Nr.: 431399415B	Ref.Nr.: 443412377
<b>F8-3001</b>	<b>F8-3002</b>	<b>F8-3007</b>	<b>F8-3046</b>	<b>F8-4009</b>	<b>F8-4021</b>	<b>F8-4026</b>
Ref.Nr.: 443399419	Ref.Nr.: 431399419A	Ref.Nr.: 431412249D	Ref.Nr.: 049129761	Ref.Nr.: 431121273	Ref.Nr.: 443199379E	Ref.Nr.: 817253147
<b>F8-4028</b>	<b>F8-4043</b>	<b>F8-4062</b>	<b>F8-4065</b>	<b>F8-4073</b>	<b>F8-4086</b>	<b>F8-5081</b>
Ref.Nr.: 431399151D	Ref.Nr.: 8A0407181	Ref.Nr.: 811412131A	Ref.Nr.: 811412135A	Ref.Nr.: 811419831B	Ref.Nr.: 893512131	Ref.Nr.: 811411327A

Article Description



Article Nr.

Fitting Position



<b>100 (43, C2)</b>			<b>06/1976 → 07/1982</b>		
Mounting, automatic transmission	1.6, 1.9, 2.0, 2.1		<b>F8-4028</b>		H=42; D=11; D1=50; D2=80; T [mm]=94
Mounting, automatic transmission	2.0 D	ch.→81-H-299999;	<b>F8-4028</b>		H=42; D=11; D1=50; D2=80; T [mm]=94
Rubber Buffer, suspension	1.6, 1.9		<b>F8-4061</b>		H=63; d1=24; d2=27; D1=52; D2=62
Rubber Buffer, suspension	2.0 D, 2.1	08/1979 →	<b>F8-4061</b>		H=63; d1=24; d2=27; D1=52; D2=62
Protective Cap/Bellow, shock absorber	1.6, 2.0 D, 2.1	01/1980 →	<b>F8-4066</b>	⊕ ⊕	H=105; D1=69; D2=105
Protective Cap/Bellow, shock absorber	1.9		<b>F8-4066</b>	⊕ ⊕	H=105; D1=69; D2=105
Bellow, steering	All Models		<b>F8-4070</b>		L=530; D1=40; D2=48
Bellow, driveshaft	1.9		<b>F8-4080</b>	⊕ ⊕	H=95; D1=29; D2=96
Engine Mounting	2.0 D		<b>F8-6925</b>	⊕ ⊕	
<b>100 Avant (43, C2)</b>			<b>07/1977 → 02/1983</b>		
Dust Cover Kit, shock absorber	All Models		<b>AK-735013</b>	⊕ ⊕ ⊕	
Control Arm-/Trailing Arm Bush	1.6, 1.9, 2.0 D, 2.1	ch.43-C-007001→	<b>F8-1017</b>	⊕ ⊕ ⊕	H=23; d=16; D=58
Control Arm-/Trailing Arm Bush	2.0		<b>F8-1017</b>	⊕ ⊕ ⊕	H=23; d=16; D=58
Control Arm-/Trailing Arm Bush	All Models		<b>F8-1018</b>	⊕ ⊕ ⊕	H1=31; H2=58; d=12; D1=21; D2=46
Mounting, axle beam	All Models	ch.4392127796→	<b>F8-1019</b>	⊕ ⊕ ⊕	H1=33; H2=43; d=12; D=56
Engine Mounting	1.9, 2.1	01/1982 →	<b>F8-1020</b>	⊕ ⊕ ⊕	H=97; D=114; T [mm]=145
Mounting, axle bracket	2.0, 2.0 D, 2.1		<b>F8-1022</b>	⊕ ⊕ ⊕	H=57; d=12; D1=46; D2=62
Top Strut Mounting	1.6, 2.0, 2.0 D, 2.1	01/1980 →;	<b>F8-1023</b>	⊕ ⊕ ⊕	H=26; d=17; D=58
Top Strut Mounting	1.9		<b>F8-1023</b>	⊕ ⊕ ⊕	H=26; d=17; D=58
Mounting, axle bracket	1.6		<b>F8-3001</b>	⊕ ⊕ ⊕	H=52; d=12; D1=51; D2=69
Mounting, axle bracket	1.9, 2.0, 2.0 D, 2.1		<b>F8-3002</b>	⊕ ⊕ ⊕	H=51; d=12; D1=53; D2=67
Mounting, axle bracket	2.1	ch.→44-M-050000	<b>F8-3002</b>	⊕ ⊕ ⊕	H=51; d=12; D1=53; D2=67
Anti-Friction Bearing	All Models		<b>F8-3007</b>		H=15; d=81; D=102
Flange, carburettor	1.6	01/1978 →; Engine119264→	<b>F8-3046</b>		H=23
Flange, carburettor	2.1		<b>F8-3046</b>		H=23
Mounting, radiator	1.9, 2.0 D		<b>F8-4009</b>		H1=15; H2=37; D=39; Outer Thread [mm]=M8 x 1,50
Mounting, radiator	2.1	WB	<b>F8-4009</b>		H1=15; H2=37; D=39; Outer Thread [mm]=M8 x 1,50
Mounting, radiator	2.1	WC	<b>F8-4009</b>		H1=15; H2=37; D=39; Outer Thread [mm]=M8 x 1,50

<b>AK-735013</b>	<b>F8-1017</b>	<b>F8-1018</b>	<b>F8-1019</b>	<b>F8-1020</b>	<b>F8-1022</b>	<b>F8-1023</b>
Ref.Nr.:	Ref.Nr.: 431407181F	Ref.Nr.: 431407183A	Ref.Nr.: 431511247C	Ref.Nr.: 443199379	Ref.Nr.: 431399415B	Ref.Nr.: 443412377
<b>F8-3001</b>	<b>F8-3002</b>	<b>F8-3007</b>	<b>F8-3046</b>	<b>F8-4009</b>	<b>F8-4021</b>	<b>F8-4028</b>
Ref.Nr.: 443399419	Ref.Nr.: 431399419A	Ref.Nr.: 431412249D	Ref.Nr.: 049129761	Ref.Nr.: 431121273	Ref.Nr.: 443199379E	Ref.Nr.: 431399151D
<b>F8-4061</b>	<b>F8-4066</b>	<b>F8-4070</b>	<b>F8-4080</b>	<b>F8-6925</b>		
Ref.Nr.: 443412121A	Ref.Nr.: 431412175D	Ref.Nr.: 431419831	Ref.Nr.: 113501149	Ref.Nr.: 443199381J		

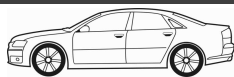
**Article Description****Article Nr.****Fitting Position**

<b>100 Avant (43, C2)</b>		<b>07/1977 → 02/1983</b>		
Engine Mounting	1.9		<b>F8-4021</b> ⊕ ⊕	H=96; D=114; τ [mm]=146
Engine Mounting	2.1	Engine020483→	<b>F8-4021</b> ⊕	H=96; D=114; τ [mm]=146
Engine Mounting	2.1	Engine081137→	<b>F8-4021</b> ⊕	H=96; D=114; τ [mm]=146
Rubber Buffer, silencer	1.6, 1.9, 2.0 D, 2.1		<b>F8-4026</b>	H=12; W=57, 60
Mounting, automatic transmission	1.6, 2.0 D, 2.1		<b>F8-4028</b>	H=42; D=11; D1=50; D2=80; τ [mm]=94
Mounting, automatic transmission	1.9		<b>F8-4028</b>	H=42; D=11; D1=50; D2=80; τ [mm]=94
Mounting, automatic transmission	2.0		<b>F8-4028</b>	H=42; D=11; D1=50; D2=80; τ [mm]=94
Mounting, automatic transmission	2.1		<b>F8-4028</b>	H=42; D=11; D1=50; D2=80; τ [mm]=94
Rubber Buffer, suspension	1.6, 2.0, 2.0 D, 2.1	08/1979 →	<b>F8-4061</b>	H=63; d1=24; d2=27; D1=52; D2=62
Rubber Buffer, suspension	1.9		<b>F8-4061</b>	H=63; d1=24; d2=27; D1=52; D2=62
Protective Cap/Bellow, shock absorber	1.6, 2.0, 2.0 D, 2.1	01/1980 →	<b>F8-4066</b> ⊕ ⊕	H=105; D1=69; D2=105
Protective Cap/Bellow, shock absorber	1.9		<b>F8-4066</b> ⊕ ⊕	H=105; D1=69; D2=105
Bellow, steering	All Models		<b>F8-4070</b>	L=530; D1=40; D2=48
Bellow, driveshaft	1.6		<b>F8-4080</b> ⊕ ⊕	H=95; D1=29; D2=96
Engine Mounting	2.0 D		<b>F8-6925</b> ⊕ ⊕	
<b>100 (44, 44Q, C3)</b>		<b>08/1982 → 07/1991</b>		
Dust Cover Kit, shock absorber	1.8, 1.8 CAT, 1.8 quattro, 1.8 quattro CAT, 1.9, 2.0, 2.0 CAT, 2.0 D, 2.0 D Turbo, 2.1, 2.2, 2.2 CAT, 2.2 E quattro, 2.2 E Turbo quattro, 2.2 quattro, 2.2 quattro CAT, 2.2 Turbo, 2.3 E, 2.3 E quattro, 2.3 quattro, 2.4 D, 2.5 TDI		<b>AK-735020</b> ⊕ ⊕	
Dust Cover Kit, shock absorber	1.8, 1.8 CAT, 1.9, 2.0, 2.0 CAT, 2.0 D, 2.0 D Turbo, 2.1, 2.2, 2.2 CAT, 2.2 Turbo, 2.3 E, 2.4 D, 2.5 TDI		<b>AK-735125</b> ⊕ ⊕	
Control Arm-/Trailing Arm Bush	1.8, 1.8 CAT, 1.8 quattro, 1.8 quattro CAT, 1.9, 2.0, 2.0 CAT, 2.0 D, 2.0 D Turbo, 2.1, 2.2, 2.2 CAT, 2.2 E quattro, 2.2 E Turbo quattro, 2.2 quattro, 2.2 quattro CAT, 2.2 Turbo, 2.3 E, 2.3 E quattro, 2.3 quattro, 2.4 D, 2.5 TDI		<b>F8-1017</b> ⊕ ⊕	H=23; d=16; D=58
Control Arm-/Trailing Arm Bush	1.8, 1.8 CAT, 1.8 quattro, 1.8 quattro CAT, 1.9, 2.0, 2.0 CAT, 2.0 D, 2.0 D Turbo, 2.1, 2.2, 2.2 CAT, 2.2 E quattro, 2.2 E Turbo quattro, 2.2 quattro, 2.2 quattro CAT, 2.2 Turbo, 2.3 E, 2.3 E quattro, 2.3 quattro, 2.4 D, 2.5 TDI		<b>F8-1018</b> ⊕ ⊕	H1=31; H2=58; d=12; D1=21; D2=46
Mounting, axle beam	1.8, 1.8 CAT, 1.9, 2.0, 2.0 CAT, 2.0 D, 2.0 D Turbo, 2.1, 2.2, 2.2 CAT, 2.2 Turbo, 2.3 E, 2.4 D, 2.5 TDI		<b>F8-1019</b> ⊕ ⊕	H1=33; H2=43; d=12; D=56

<b>AK-735020</b>	<b>AK-735125</b>	<b>F8-1017</b>	<b>F8-1018</b>	<b>F8-1019</b>	<b>F8-1020</b>	<b>F8-4021</b>
Ref.Nr.:	Ref.Nr.: 4A0512129	Ref.Nr.: 431407181F	Ref.Nr.: 431407183A	Ref.Nr.: 431511247C	Ref.Nr.: 443199379	Ref.Nr.: 443199379E
<b>F8-4026</b>	<b>F8-4028</b>	<b>F8-4061</b>	<b>F8-4066</b>	<b>F8-4070</b>	<b>F8-4080</b>	<b>F8-6925</b>
Ref.Nr.: 817253147	Ref.Nr.: 431399151D	Ref.Nr.: 443412121A	Ref.Nr.: 431412175D	Ref.Nr.: 431419831	Ref.Nr.: 113501149	Ref.Nr.: 443199381J

Article Description			Article Nr.	Fitting Position	
---------------------	--	--	-------------	------------------	--

100 (44, 44Q, C3)			08/1982 → 07/1991		
Engine Mounting	1.9, 2.0, 2.0 CAT, 2.1, 2.2, 2.2 E quattro, 2.2 E Turbo quattro, 2.2 quattro, 2.2 Turbo, 2.3 E, 2.3 E quattro		F8-1020		H=97; D=114; T [mm]=145
Engine Mounting	1.9, 2.0, 2.0 CAT, 2.1, 2.2, 2.2 E quattro, 2.2 E Turbo quattro, 2.2 quattro, 2.2 Turbo, 2.3 E		F8-1021		H=97; D=114; T [mm]=143
Engine Mounting	2.0 D, 2.0 D Turbo		F8-1021		H=97; D=114; T [mm]=143
Engine Mounting	2.3 E quattro		F8-1021		H=97; D=114; T [mm]=143
Mounting, axle bracket	1.9, 2.0, 2.0 CAT, 2.0 D, 2.0 D Turbo, 2.1, 2.2, 2.2 CAT, 2.2 E quattro, 2.2 E Turbo quattro, 2.2 quattro, 2.2 quattro CAT, 2.2 Turbo, 2.3 E, 2.3 E quattro, 2.3 quattro, 2.4 D, 2.5 TDI		F8-1022		H=57; d=12; D1=46; D2=62
Top Strut Mounting	1.8, 1.8 CAT, 1.8 quattro, 1.8 quattro CAT, 1.9, 2.0, 2.0 CAT, 2.0 D, 2.0 D Turbo, 2.1, 2.2, 2.2 E quattro, 2.2 E Turbo quattro, 2.2 quattro, 2.2 Turbo, 2.3 E, 2.3 E quattro, 2.4 D, 2.5 TDI		F8-1023		H=26; d=17; D=58
Mounting, axle bracket	1.8, 1.8 CAT, 1.8 quattro, 1.8 quattro CAT		F8-3001		H=52; d=12; D1=51; D2=69
Mounting, axle bracket	1.8 CAT, 1.8 quattro CAT, 1.9, 2.0, 2.0 CAT, 2.0 D, 2.0 D Turbo, 2.1, 2.2, 2.2 E Turbo quattro, 2.2 quattro, 2.2 Turbo, 2.3 E, 2.3 E quattro, 2.4 D, 2.5 TDI		F8-3002		H=51; d=12; D1=53; D2=67
Mounting, axle bracket	2.2 E quattro	ch.→44-M-050000	F8-3002		H=51; d=12; D1=53; D2=67
Stabiliser Mounting	1.8, 1.8 CAT, 1.8 quattro, 1.8 quattro CAT, 1.9, 2.0 CAT, 2.0 D Turbo, 2.1, 2.2, 2.2 CAT, 2.2 E quattro, 2.2 E Turbo quattro, 2.2 quattro, 2.2 quattro CAT, 2.3 E, 2.3 E quattro, 2.3 quattro, 2.4 D, 2.5 TDI	ch.→44-M-050000; for OE: 443 411 327	F8-3005		H=45; d=20; W=46
Stabiliser Mounting	1.8, 2.0, 2.0 D, 2.0 D Turbo, 2.2, 2.2 Turbo, 2.3 E	ch.44-H-180001→; ch.→44-M-050000; 07/1987 →; for OE: 443 411 327	F8-3005		H=45; d=20; W=46
Anti-Friction Bearing	All Models		F8-3007		H=15; d=81; D=102
Top Strut Mounting	1.8 quattro	ch.→44-M-050000;	F8-3010		H=33; d=10; D=79
Top Strut Mounting	1.8 quattro, 1.8 quattro CAT, 2.2 E quattro, 2.2 E Turbo quattro, 2.2 quattro, 2.3 E quattro		F8-3010		H=33; d=10; D=79
Top Strut Mounting	1.8, 1.8 CAT, 1.9, 2.0, 2.0 CAT, 2.0 D, 2.0 D Turbo, 2.1, 2.2, 2.2 Turbo, 2.3 E, 2.4 D, 2.5 TDI		F8-3010		H=33; d=10; D=79
Flange, carburettor	1.8		F8-3044		H=21
Flange, carburettor	1.8, 1.8 CAT, 1.8 quattro		F8-3045		H=21
Flange, carburettor	1.8, 1.8 CAT		F8-3047		H=24
Flange, carburettor	1.8 CAT, 1.8 quattro CAT	01/1988 →	F8-3048		H=27; d=40
Mounting, radiator	1.8	ch.44-J-200100→;  JW;	F8-4009		H1=15; H2=37; D=39; Outer Thread [mm]=M8 x 1,50
Mounting, radiator	1.8	ch.44-J-200100→;  NP;	F8-4009		H1=15; H2=37; D=39; Outer Thread [mm]=M8 x 1,50
Mounting, radiator	1.8, 1.8 CAT, 1.8 quattro, 1.8 quattro CAT	ch.44-J-200100→;	F8-4009		H1=15; H2=37; D=39; Outer Thread [mm]=M8 x 1,50

<b>F8-1020</b>	<b>F8-1021</b>	<b>F8-1022</b>	<b>F8-1023</b>	<b>F8-3001</b>	<b>F8-3002</b>	<b>F8-3005</b>
Ref.Nr.: 443199379	Ref.Nr.: 443199382	Ref.Nr.: 431399415B	Ref.Nr.: 443412377	Ref.Nr.: 443399419	Ref.Nr.: 431399419A	Ref.Nr.: 443411327
<b>F8-3007</b>	<b>F8-3010</b>	<b>F8-3044</b>	<b>F8-3045</b>	<b>F8-3047</b>	<b>F8-3048</b>	<b>F8-4009</b>
Ref.Nr.: 431412249D	Ref.Nr.: 443512331	Ref.Nr.: 026129761A	Ref.Nr.: 027129761	Ref.Nr.: 050129761C	Ref.Nr.: 050129761B	Ref.Nr.: 431121273



**Article Description****Article Nr.****Fitting Position****100 (44, 44Q, C3)****08/1982 → 07/1991**

Mounting, radiator	1.9, 2.0, 2.0 CAT, 2.0 D, 2.0 D Turbo, 2.1, 2.2, 2.2 E quattro, 2.2 E Turbo quattro, 2.2 quattro, 2.2 Turbo, 2.3 E, 2.3 E quattro, 2.4 D, 2.5 TDI		<b>F8-4009</b>		H1=15; H2=37; D=39; Outer Thread [mm]=M8 x 1,50
Mounting, radiator	1.8 quattro CAT	4B	<b>F8-4011</b>		H1=16; H2=38; D=30; Outer Thread [mm]=M8 x 1,25
Mounting, radiator	1.8, 1.8 CAT		<b>F8-4011</b>		H1=16; H2=38; D=30; Outer Thread [mm]=M8 x 1,25
Mounting, radiator	1.8, 1.8 quattro	PH	<b>F8-4011</b>		H1=16; H2=38; D=30; Outer Thread [mm]=M8 x 1,25
Flange, carburettor	1.8		<b>F8-4012</b>		H=20; L=146; W=112
Engine Mounting	2.4 D, 2.5 TDI		<b>F8-4019</b>		H=47; d=26; D1=48; D2=67
Engine Mounting	1.8	ch.→44-J-200099	<b>F8-4022</b>		H=60; d=11; D=89; τ [mm]=145
Engine Mounting	1.8, 1.8 CAT	ch.44-J-200100→;	<b>F8-4022</b>		H=60; d=11; D=89; τ [mm]=145
Rubber Buffer, silencer	2.2 E Turbo quattro, 2.2 quattro		<b>F8-4026</b>		H=12; W=57, 60
Mounting, automatic transmission	1.8 CAT, 1.8 quattro CAT, 2.0 CAT, 2.2 Turbo, 2.3 E, 2.5 TDI		<b>F8-4028</b>		H=42; D=11; D1=50; D2=80; τ [mm]=94
Mounting, automatic transmission	1.8, 1.8 quattro, 1.9, 2.0, 2.0 D, 2.1, 2.2, 2.2 E quattro, 2.2 E Turbo quattro, 2.2 quattro, 2.3 E quattro		<b>F8-4028</b>		H=42; D=11; D1=50; D2=80; τ [mm]=94
Mounting, automatic transmission	2.0 D Turbo		<b>F8-4028</b>		H=42; D=11; D1=50; D2=80; τ [mm]=94
Mounting, automatic transmission	2.0 D Turbo, 2.4 D		<b>F8-4028</b>		H=42; D=11; D1=50; D2=80; τ [mm]=94
Rubber Buffer, suspension	1.8 CAT, 1.8 quattro CAT	PH	<b>F8-4061</b>		H=63; d1=24; d2=27; D1=52; D2=62
Rubber Buffer, suspension	1.8, 1.8 quattro, 1.9, 2.0, 2.0 CAT, 2.0 D, 2.0 D Turbo, 2.1, 2.2, 2.2 CAT, 2.2 Turbo, 2.3 E, 2.3 E quattro, 2.4 D		<b>F8-4061</b>		H=63; d1=24; d2=27; D1=52; D2=62
Protective Cap/Bellow, shock absorber	1.8, 1.8 CAT, 1.8 quattro, 1.8 quattro CAT, 1.9, 2.0, 2.0 CAT, 2.0 D, 2.0 D Turbo, 2.1, 2.2, 2.2 E quattro, 2.2 E Turbo quattro, 2.2 quattro, 2.2 Turbo, 2.3 E, 2.3 E quattro, 2.4 D, 2.5 TDI		<b>F8-4066</b>		H=105; D1=69; D2=105
Bellow, steering	1.8, 1.8 CAT, 1.8 quattro, 1.8 quattro CAT, 1.9, 2.0, 2.0 CAT, 2.0 D, 2.0 D Turbo, 2.1, 2.2, 2.2 CAT, 2.2 E quattro, 2.2 E Turbo quattro, 2.2 quattro, 2.2 quattro CAT, 2.2 Turbo, 2.3 E, 2.3 E quattro, 2.3 quattro, 2.4 D, 2.5 TDI		<b>F8-4070</b>		L=530; D1=40; D2=48
Suspension, panhard rod	1.8, 1.8 CAT, 1.9, 2.0, 2.0 CAT, 2.0 D, 2.0 D Turbo, 2.1, 2.2, 2.2 Turbo, 2.3 E, 2.4 D, 2.5 TDI		<b>F8-5344</b>		d=12.2
Mounting, axle beam	1.8 quattro, 1.8 quattro CAT, 2.2 E quattro, 2.2 quattro	ch.44-G-073363→; 01/1986 →	<b>F8-5541</b>		d=12; D=58; W=35.8, 58
Mounting, axle beam	1.8 quattro, 2.2 E Turbo quattro, 2.3 E quattro	ch.44-G-073363→	<b>F8-5541</b>		d=12; D=58; W=35.8, 58
Mounting, axle bracket	2.4 D	ch.4A-M-000001→	<b>F8-5543</b>		H=60; D=55
Control Arm-/Trailing Arm Bush	1.8 quattro, 1.8 quattro CAT, 2.2 E quattro, 2.2 E Turbo quattro, 2.2 quattro, 2.2 quattro CAT, 2.3 E quattro, 2.3 quattro		<b>F8-5777</b>		H=23; d=14; D=44

<b>F8-4009</b>	<b>F8-4011</b>	<b>F8-4012</b>	<b>F8-4019</b>	<b>F8-4022</b>	<b>F8-4026</b>	<b>F8-4028</b>
Ref.Nr.: 431121273	Ref.Nr.: 803121273	Ref.Nr.: 050129761D	Ref.Nr.: 893199339	Ref.Nr.: 443199381	Ref.Nr.: 817253147	Ref.Nr.: 431399151D
<b>F8-4061</b>	<b>F8-4066</b>	<b>F8-4070</b>	<b>F8-5344</b>	<b>F8-5541</b>	<b>F8-5543</b>	<b>F8-5777</b>
Ref.Nr.: 443412121A	Ref.Nr.: 431412175D	Ref.Nr.: 431419831	Ref.Nr.: 431505172	Ref.Nr.: 4D0511523C	Ref.Nr.: 4A0399415	Ref.Nr.: 443511247D
<b>F8-6925</b>						
Ref.Nr.: 443199381J						

Article Description			Article Nr.	Fitting Position	
---------------------	--	--	-------------	------------------	--

100 (44, 44Q, C3)			08/1982 → 07/1991		
Engine Mounting	1.8	ch.44-H-084706, 44-J-200100→; ch.→44-J-200099, 44-M-050000; ⚙	F8-6925	⊕ ⊕	
Engine Mounting	1.8	ch.44-H-084706, 44-J-200100→; ch.→44-J-200099, 44-M-050000; ⚙ DS, JW, NP; ⚙	F8-6925	⊕ ⊕	
Engine Mounting	1.8 CAT	ch.44-J-200100→; ch.→44-M-050000; ⚙	F8-6925	⊕ ⊕	
Engine Mounting	2.0 D Turbo	ch.44-J-200100→; ch.→44-M-050000	F8-6925	⊕ ⊕	
Engine Mounting	2.0 D, 2.0 D Turbo	ch.44-H-084746→; ch.→44-G-300000; ⚙, ⚙	F8-6925	⊕ ⊕	

100 Avant (44, 44Q, C3)			08/1982 → 11/1990		
Dust Cover Kit, shock absorber	1.8, 1.8 CAT, 2.0, 2.0 D, 2.0 E, 2.0 E CAT, 2.0 TD, 2.1, 2.2, 2.2 CAT, 2.2 Turbo, 2.3, 2.4 D, 2.5 TDI		AK-735020	⊕ ⊕ ⊕	
Dust Cover Kit, shock absorber	1.8, 1.8 CAT, 1.9, 2.0, 2.0 D, 2.0 E, 2.0 E CAT, 2.0 TD, 2.1, 2.2, 2.2 CAT, 2.2 Turbo, 2.3, 2.4 D, 2.5 TDI		AK-735125	⊕ ⊕ ⊕	
Control Arm-/Trailing Arm Bush	1.8, 1.8 CAT, 1.8 quattro, 1.8 quattro CAT, 1.9, 2.0, 2.0 D, 2.0 E, 2.0 E CAT, 2.0 TD, 2.1, 2.2, 2.2 CAT, 2.2 E quattro, 2.2 quattro, 2.2 quattro CAT, 2.2 Turbo, 2.2 Turbo quattro, 2.3, 2.3 E quattro, 2.3 quattro, 2.4 D, 2.5 TDI		F8-1017	⊕ ⊕ ⊕	H=23; d=16; D=58
Control Arm-/Trailing Arm Bush	1.8, 1.8 CAT, 1.8 quattro, 1.8 quattro CAT, 1.9, 2.0, 2.0 D, 2.0 E, 2.0 E CAT, 2.0 TD, 2.1, 2.2, 2.2 CAT, 2.2 E quattro, 2.2 quattro, 2.2 quattro CAT, 2.2 Turbo, 2.2 Turbo quattro, 2.3, 2.3 E quattro, 2.3 quattro, 2.4 D, 2.5 TDI		F8-1018	⊕ ⊕ ⊕	H1=31; H2=58; d=12; D1=21; D2=46
Mounting, axle beam	1.8, 1.8 CAT, 1.9, 2.0, 2.0 D, 2.0 E, 2.0 E CAT, 2.0 TD, 2.1, 2.2, 2.2 CAT, 2.2 Turbo, 2.3, 2.4 D, 2.5 TDI		F8-1019	⊕ ⊕ ⊕	H1=33; H2=43; d=12; D=56
Engine Mounting	1.9, 2.0, 2.0 E, 2.0 E CAT, 2.1, 2.2, 2.2 E quattro, 2.2 quattro, 2.2 Turbo, 2.2 Turbo quattro, 2.3, 2.3 E quattro		F8-1020	⊕ ⊕ ⊕	H=97; D=114; T [mm]=145
Engine Mounting	1.9, 2.0, 2.0 E, 2.0 E CAT, 2.1, 2.2, 2.2 E quattro, 2.2 quattro, 2.2 Turbo, 2.2 Turbo quattro, 2.3	⚙	F8-1021	⊕ ⊕ ⊕	H=97; D=114; T [mm]=143
Engine Mounting	2.0 D, 2.0 TD	⚙	F8-1021	⊕ ⊕ ⊕	H=97; D=114; T [mm]=143
Engine Mounting	2.3 E quattro		F8-1021	⊕ ⊕ ⊕	H=97; D=114; T [mm]=143
Mounting, axle bracket	1.9, 2.0, 2.0 D, 2.0 E, 2.0 E CAT, 2.0 TD, 2.1, 2.2, 2.2 CAT, 2.2 E quattro, 2.2 quattro, 2.2 quattro CAT, 2.2 Turbo, 2.2 Turbo quattro, 2.3, 2.3 E quattro, 2.3 quattro, 2.4 D, 2.5 TDI		F8-1022	⊕ ⊕ ⊕	H=57; d=12; D1=46; D2=62
Top Strut Mounting	1.8, 1.8 CAT, 1.8 quattro, 1.8 quattro CAT, 1.9, 2.0, 2.0 D, 2.0 E, 2.0 E CAT, 2.0 TD, 2.1, 2.2, 2.2 E quattro, 2.2 quattro, 2.2 Turbo, 2.2 Turbo quattro, 2.3, 2.3 E quattro, 2.4 D, 2.5 TDI	⚙	F8-1023	⊕ ⊕ ⊕	H=26; d=17; D=58
Mounting, axle bracket	1.8, 1.8 CAT, 1.8 quattro, 1.8 quattro CAT	⚙	F8-3001	⊕ ⊕ ⊕	H=52; d=12; D1=51; D2=69
Mounting, axle bracket	1.8 CAT, 1.9, 2.2 quattro, 2.3 E quattro, 2.5 TDI	ch.→44-M-050000	F8-3002	⊕ ⊕ ⊕	H=51; d=12; D1=53; D2=67
Mounting, axle bracket	1.8 quattro CAT, 2.0, 2.0 D, 2.0 E, 2.0 E CAT, 2.0 TD, 2.1, 2.2, 2.2 E quattro, 2.2 Turbo, 2.2 Turbo quattro, 2.3, 2.4 D		F8-3002	⊕ ⊕ ⊕	H=51; d=12; D1=53; D2=67

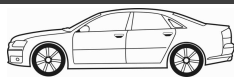

**Article Description****Article Nr.****Fitting Position**

<b>100 Avant (44, 44Q, C3)</b>		<b>08/1982 → 11/1990</b>		
Stabiliser Mounting	1.8, 1.8 CAT, 1.8 quattro, 1.8 quattro CAT, 1.9, 2.0, 2.0 D, 2.0 E, 2.0 E CAT, 2.0 TD, 2.1, 2.2, 2.2 CAT, 2.2 E quattro, 2.2 quattro, 2.2 quattro CAT, 2.2 Turbo, 2.2 Turbo quattro, 2.3, 2.3 E quattro, 2.3 quattro, 2.4 D, 2.5 TDI	ch.→44-M-050000; for OE: 443 411 327	<b>F8-3005</b>	H=45; d=20; W=46
Anti-Friction Bearing	All Models		<b>F8-3007</b>	H=15; d=81; D=102
Top Strut Mounting	1.8 quattro, 1.8 quattro CAT	ch.→44-M-050000;	<b>F8-3010</b>	H=33; d=10; D=79
Top Strut Mounting	1.8, 1.8 CAT, 1.9, 2.0, 2.0 D, 2.0 E, 2.0 E CAT, 2.0 TD, 2.1, 2.2, 2.2 Turbo, 2.3, 2.4 D, 2.5 TDI		<b>F8-3010</b>	H=33; d=10; D=79
Top Strut Mounting	2.2 E quattro, 2.2 quattro, 2.2 Turbo quattro, 2.3 E quattro		<b>F8-3010</b>	H=33; d=10; D=79
Flange, carburettor	1.8		<b>F8-3044</b>	H=21
Flange, carburettor	1.8, 1.8 CAT, 1.8 quattro		<b>F8-3045</b>	H=21
Flange, carburettor	1.8, 1.8 CAT		<b>F8-3047</b>	H=24
Flange, carburettor	1.8 CAT, 1.8 quattro CAT	01/1988 →	<b>F8-3048</b>	H=27; d=40
Mounting, radiator	1.8	ch.44-J-200100→;  JW;	<b>F8-4009</b>	H1=15; H2=37; D=39; Outer Thread [mm]=M8 x 1,50
Mounting, radiator	1.8	ch.44-J-200100→;  NP;	<b>F8-4009</b>	H1=15; H2=37; D=39; Outer Thread [mm]=M8 x 1,50
Mounting, radiator	1.8, 1.8 CAT, 1.8 quattro, 1.8 quattro CAT	ch.44-J-200100→;	<b>F8-4009</b>	H1=15; H2=37; D=39; Outer Thread [mm]=M8 x 1,50
Mounting, radiator	1.9, 2.0, 2.0 D, 2.0 E, 2.0 E CAT, 2.0 TD, 2.1, 2.2, 2.2 E quattro, 2.2 quattro, 2.2 Turbo, 2.2 Turbo quattro, 2.3, 2.3 E quattro, 2.4 D, 2.5 TDI		<b>F8-4009</b>	H1=15; H2=37; D=39; Outer Thread [mm]=M8 x 1,50
Mounting, radiator	1.8		<b>F8-4011</b>	H1=16; H2=38; D=30; Outer Thread [mm]=M8 x 1,25
Mounting, radiator	1.8 CAT, 1.8 quattro CAT	4B	<b>F8-4011</b>	H1=16; H2=38; D=30; Outer Thread [mm]=M8 x 1,25
Mounting, radiator	1.8, 1.8 quattro	PH	<b>F8-4011</b>	H1=16; H2=38; D=30; Outer Thread [mm]=M8 x 1,25
Flange, carburettor	1.8	01/1989 →	<b>F8-4012</b>	H=20; L=146; W=112
Engine Mounting	2.4 D, 2.5 TDI		<b>F8-4019</b>	H=47; d=26; D1=48; D2=67
Engine Mounting	1.8	ch.→44-J-200099	<b>F8-4022</b>	H=60; d=11; D=89; $\tau$ [mm]=145
Engine Mounting	1.8, 1.8 CAT	ch.44-J-200100→;	<b>F8-4022</b>	H=60; d=11; D=89; $\tau$ [mm]=145
Rubber Buffer, silencer	2.3		<b>F8-4026</b>	H=12; W=57, 60
Mounting, automatic transmission	1.8, 1.8 CAT, 2.2 Turbo, 2.3, 2.3 E quattro, 2.4 D		<b>F8-4028</b>	H=42; D=11; D1=50; D2=80; $\tau$ [mm]=94
Mounting, automatic transmission	1.8, 1.8 quattro, 1.8 quattro CAT, 1.9, 2.0 E, 2.1, 2.2, 2.2 E quattro, 2.2 quattro, 2.2 Turbo quattro		<b>F8-4028</b>	H=42; D=11; D1=50; D2=80; $\tau$ [mm]=94
Mounting, automatic transmission	2.0		<b>F8-4028</b>	H=42; D=11; D1=50; D2=80; $\tau$ [mm]=94
Mounting, automatic transmission	2.0 D	ch.→81-H-299999; ,	<b>F8-4028</b>	H=42; D=11; D1=50; D2=80; $\tau$ [mm]=94



Article Description



Article Nr.

Fitting Position



### 100 Avant (44, 44Q, C3)

08/1982 → 11/1990

Mounting, automatic transmission	2.0 E CAT, 2.0 TD, 2.5 TDI		<b>F8-4028</b>		H=42; D=11; D1=50; D2=80; T [mm]=94
Mounting, automatic transmission	2.0 TD	ch.→81-H-299999;	<b>F8-4028</b>		H=42; D=11; D1=50; D2=80; T [mm]=94
Rubber Buffer, suspension	1.8 quattro CAT	PH	<b>F8-4061</b>		H=63; d1=24; d2=27; D1=52; D2=62
Rubber Buffer, suspension	1.8, 1.8 CAT, 1.8 quattro, 1.9, 2.0, 2.0 D, 2.0 E, 2.0 E CAT, 2.0 TD, 2.1, 2.2, 2.2 CAT, 2.2 Turbo, 2.3, 2.3 E quattro, 2.4 D		<b>F8-4061</b>		H=63; d1=24; d2=27; D1=52; D2=62
Protective Cap/Bellow, shock absorber	1.8, 1.8 CAT, 1.8 quattro, 1.8 quattro CAT, 1.9, 2.0, 2.0 D, 2.0 E, 2.0 E CAT, 2.0 TD, 2.1, 2.2, 2.2 E quattro, 2.2 quattro, 2.2 Turbo, 2.2 Turbo quattro, 2.3, 2.3 E quattro, 2.4 D, 2.5 TDI		<b>F8-4066</b>		H=105; D1=69; D2=105
Bellow, steering	1.8, 1.8 CAT, 1.8 quattro, 1.8 quattro CAT, 1.9, 2.0, 2.0 D, 2.0 E, 2.0 E CAT, 2.0 TD, 2.1, 2.2, 2.2 CAT, 2.2 E quattro, 2.2 quattro, 2.2 quattro CAT, 2.2 Turbo, 2.2 Turbo quattro, 2.3, 2.3 E quattro, 2.3 quattro, 2.4 D, 2.5 TDI		<b>F8-4070</b>		L=530; D1=40; D2=48
Suspension, panhard rod	1.8, 1.8 CAT, 1.9, 2.0, 2.0 D, 2.0 E, 2.0 E CAT, 2.0 TD, 2.1, 2.2, 2.2 Turbo, 2.3, 2.4 D, 2.5 TDI		<b>F8-5344</b>		d=12.2
Mounting, axle beam	1.8 quattro, 1.8 quattro CAT, 2.2 E quattro, 2.2 quattro	ch.44-G-073363→; 01/1986 →	<b>F8-5541</b>		d=12; D=58; W=35.8, 58
Mounting, axle beam	1.8 quattro, 2.2 Turbo quattro, 2.3 E quattro	ch.44-G-073363→	<b>F8-5541</b>		d=12; D=58; W=35.8, 58
Control Arm-/Trailing Arm Bush	1.8 quattro, 1.8 quattro CAT, 2.2 E quattro, 2.2 quattro, 2.2 quattro CAT, 2.2 Turbo quattro, 2.3 E quattro, 2.3 quattro		<b>F8-5777</b>		H=23; d=14; D=44
Engine Mounting	1.8	ch.44-H-084706, 44-J-200100→; ch.→44-J-200099, 44-M-050000;	<b>F8-6925</b>		
Engine Mounting	1.8	ch.44-H-084706, 44-J-200100→; ch.→44-J-200099, 44-M-050000;  JW, NP;	<b>F8-6925</b>		
Engine Mounting	1.8 CAT	ch.44-J-200100→; ch.→44-M-050000;	<b>F8-6925</b>		
Engine Mounting	2.0 D	ch.44-G-300000, 44-H-084746→;	<b>F8-6925</b>		
Engine Mounting	2.0 TD	ch.44-H-084746→; ch.→44-G-300000;	<b>F8-6925</b>		
Engine Mounting	2.0 TD	ch.44-J-200100→; ch.→44-M-050000	<b>F8-6925</b>		

### 100 (4A, C4)

12/1990 → 07/1994

Dust Cover Kit, shock absorber	2.0, 2.0 E, 2.3 E, 2.4 D, 2.5 TDI, 2.6, 2.8 E		<b>AK-735020</b>		
Dust Cover Kit, shock absorber	2.0, 2.0 E, 2.0 E 16V, 2.3 E, 2.4 D, 2.5 TDI, 2.6, 2.8 E		<b>AK-735125</b>		
Control Arm-/Trailing Arm Bush	2.0, 2.0 E, 2.3 E, 2.4 D, 2.5 TDI, 2.6, 2.8 E		<b>F8-1024</b>		H1=21; H2=25; d=16; D=63
Mounting, axle bracket	2.0, 2.0 E, 2.0 E quattro, 2.3 E, 2.3 E quattro, 2.4 D, 2.5 TDI, 2.8 E, 2.8 E quattro	ch.→44-M-050000	<b>F8-3002</b>		H=51; d=12; D1=53; D2=67
Mounting, automatic transmission	2.3 E, 2.3 E quattro, 2.4 D, 2.5 TDI, 2.6, 2.6 quattro, 2.8 E, 2.8 E quattro	ch.4A-M-000001→	<b>F8-3003</b>		H=69; d=11; D=65

<b>AK-735020</b>	<b>AK-735125</b>	<b>F8-1024</b>	<b>F8-3002</b>	<b>F8-3003</b>	<b>F8-4028</b>	<b>F8-4061</b>
Ref.Nr.:	Ref.Nr.: 4A0512129	Ref.Nr.: 4A0407181A	Ref.Nr.: 431399419A	Ref.Nr.: 4A0399419E	Ref.Nr.: 431399151D	Ref.Nr.: 443412121A
<b>F8-4066</b>	<b>F8-4070</b>	<b>F8-5344</b>	<b>F8-5541</b>	<b>F8-5777</b>	<b>F8-6925</b>	
Ref.Nr.: 431412175D	Ref.Nr.: 431419831	Ref.Nr.: 431505172	Ref.Nr.: 4D0511523C	Ref.Nr.: 443511247D	Ref.Nr.: 443199381J	

**Article Description****Article Nr.****Fitting Position**

<b>100 (4A, C4)</b>				<b>12/1990 → 07/1994</b>	
Mounting, automatic transmission	S4 Turbo quattro		<b>F8-3003</b>		H=69; d=11; D=65
Mounting, automatic transmission	2.3 E, 2.3 E quattro, 2.4 D, 2.5 TDI, 2.6, 2.6 quattro, 2.8 E, 2.8 E quattro	ch.4A-M-000001→	<b>F8-3004</b>		H=69; d=11; D=65
Stabiliser Mounting	2.3 E quattro, 2.6 quattro, 2.8 E quattro	ch.4A-M-000001→; for OE: 4A0411327A	<b>F8-3006</b>		H=41; d=24; Thick. [mm]=66
Stabiliser Mounting	2.3 E, 2.4 D, 2.5 TDI, 2.6, 2.8 E	ch.4A-M-000001→; for OE: 4A0411327A;	<b>F8-3006</b>		H=41; d=24; Thick. [mm]=66
Stabiliser Mounting	2.6		<b>F8-3006</b>		H=41; d=24; Thick. [mm]=66
Anti-Friction Bearing	All Models	ch.4A-N-040000→	<b>F8-3008</b>		H=15; d=91; D=112
Top Strut Mounting	All Models	ch.4A-N-040000→;	<b>F8-3009</b>		H=41; d=17; D=73
Top Strut Mounting	2.0 E 16V quattro, 2.0 E quattro, 2.3 E quattro, 2.6 quattro, 2.8 E quattro		<b>F8-3010</b>		H=33; d=10; D=79
Top Strut Mounting	2.0, 2.0 E, 2.0 E 16V, 2.3 E, 2.4 D, 2.5 TDI, 2.6, 2.8 E		<b>F8-3010</b>		H=33; d=10; D=79
Mounting, automatic transmission	2.0, 2.0 E, 2.0 E quattro		<b>F8-3056</b>		H=70; d=11; D=65
Engine Mounting	2.3 E, 2.3 E quattro, 2.4 D, 2.5 TDI, S4 Turbo quattro		<b>F8-4019</b>		H=47; d=26; D1=48; D2=67
Engine Mounting	2.3 E, 2.3 E quattro, S4 Turbo quattro		<b>F8-4021</b>		H=96; D=114; τ [mm]=146
Rubber Buffer, silencer	2.5 TDI		<b>F8-4026</b>		H=12; W=57, 60
Mounting, automatic transmission	2.0 E quattro, 2.3 E quattro, 2.8 E quattro		<b>F8-4028</b>		H=42; D=11; D1=50; D2=80; τ [mm]=94
Mounting, automatic transmission	2.0, 2.0 E, 2.3 E, 2.8 E		<b>F8-4028</b>		H=42; D=11; D1=50; D2=80; τ [mm]=94
Mounting, automatic transmission	2.4 D, 2.5 TDI		<b>F8-4028</b>		H=42; D=11; D1=50; D2=80; τ [mm]=94
Mounting, automatic transmission	2.0, 2.0 E, 2.0 E quattro, 2.4 D, 2.5 TDI		<b>F8-4029</b>		H=125; d=9; Thick. [mm]=55; W=96
Protective Cap/Bellow, shock absorber	2.0, 2.0 E, 2.0 E quattro, 2.3 E, 2.3 E quattro, 2.4 D, 2.5 TDI, 2.6, 2.6 quattro, 2.8 E, 2.8 E quattro, S4 Turbo quattro, S4 V8 quattro		<b>F8-4066</b>		H=105; D1=69; D2=105
Bellow, steering	2.0, 2.0 E, 2.0 E 16V, 2.0 E 16V quattro, 2.0 E quattro, 2.3 E, 2.3 E quattro, 2.4 D, 2.5 TDI, 2.6, 2.6 quattro, 2.8 E, 2.8 E quattro, S4 Turbo quattro, S4 V8 quattro		<b>F8-4070</b>		L=530; D1=40; D2=48
Control Arm-/Trailing Arm Bush	2.0 E quattro, 2.3 E quattro, 2.8 E quattro, S4 Turbo quattro	01/1992 →	<b>F8-5306</b>		d=14; D=48; W=25
Control Arm-/Trailing Arm Bush	2.6 quattro, S4 V8 quattro		<b>F8-5306</b>		d=14; D=48; W=25
Mounting, axle beam	2.0, 2.0 E, 2.3 E, 2.4 D, 2.5 TDI, 2.8 E		<b>F8-5342</b>		
Suspension, panhard rod	2.0, 2.0 E, 2.3 E, 2.4 D, 2.5 TDI, 2.6, 2.8 E		<b>F8-5344</b>		d=12.2
Mounting, axle beam	2.0 E 16V quattro, 2.0 E quattro, 2.3 E quattro, 2.6 quattro, 2.8 E quattro		<b>F8-5541</b>		d=12; D=58; W=35.8, 58
Mounting, axle bracket	2.0 E 16V quattro, 2.0 E quattro, 2.3 E quattro, 2.6 quattro, 2.8 E quattro, S4 Turbo quattro, S4 V8 quattro		<b>F8-5543</b>		H=60; D=55

<b>F8-3003</b>	<b>F8-3004</b>	<b>F8-3006</b>	<b>F8-3008</b>	<b>F8-3009</b>	<b>F8-3010</b>	<b>F8-3056</b>
Ref.Nr.: 4A0399419E	Ref.Nr.: 4A0399420E	Ref.Nr.: 4A0411327A	Ref.Nr.: 4A0412249	Ref.Nr.: 4A0412377B	Ref.Nr.: 443512331	Ref.Nr.: 4A0399420
<b>F8-4019</b>	<b>F8-4021</b>	<b>F8-4026</b>	<b>F8-4028</b>	<b>F8-4029</b>	<b>F8-4066</b>	<b>F8-4070</b>
Ref.Nr.: 893199339	Ref.Nr.: 443199379E	Ref.Nr.: 817253147	Ref.Nr.: 431399151D	Ref.Nr.: 4A0399151D	Ref.Nr.: 431412175D	Ref.Nr.: 431419831
<b>F8-5306</b>	<b>F8-5342</b>	<b>F8-5344</b>	<b>F8-5541</b>	<b>F8-5543</b>		
Ref.Nr.: 4A0511247B	Ref.Nr.: 4A0511247	Ref.Nr.: 431505172	Ref.Nr.: 4D0511523C	Ref.Nr.: 4A0399415		

**Article Description**

**Article Nr.**
**Fitting Position**

<b>100 (4A, C4)</b>			<b>12/1990 → 07/1994</b>		
Mounting, axle bracket	2.0, 2.0 E, 2.0 E 16V, 2.3 E, 2.4 D, 2.5 TDI, 2.6, 2.8 E	ch.4A-M-000001→	<b>F8-5543</b>		H=60; D=55
Engine Mounting	2.0 E	Transmission Nr: CDS, CDT, CDU;	<b>F8-5544</b>		
Engine Mounting	2.0 E 16V quattro, 2.0 E quattro, 2.3 E quattro	Transmission Nr: CBD, CBE, CBF, CBL, CDE, CET, CEZ, CNT	<b>F8-5544</b>		
Engine Mounting	2.0, 2.0 E 16V, 2.3 E, 2.4 D, 2.5 TDI, 2.6, 2.8 E	Transmission Nr: CDS, CDT, CDU;  4-speed	<b>F8-5544</b>		
Engine Mounting	2.6 quattro, 2.8 E quattro, S4 V8 quattro	Transmission Nr: CBE, CBF, CBL, CDB, CDE, CET, CEZ, CNT	<b>F8-5544</b>		
Engine Mounting	2.0, 2.0 E, 2.0 E 16V, 2.0 E 16V quattro, 2.0 E quattro		<b>F8-5545</b>		
Engine Mounting	2.6, 2.6 quattro, 2.8 E, 2.8 E quattro		<b>F8-5546</b>		
Engine Mounting	2.6, 2.6 quattro, 2.8 E, 2.8 E quattro		<b>F8-5547</b>		
Rubber Buffer, suspension	2.0, 2.0 E, 2.0 E 16V, 2.0 E 16V quattro, 2.0 E quattro, 2.3 E, 2.3 E quattro, 2.4 D, 2.5 TDI, 2.6, 2.6 quattro, 2.8 E, 2.8 E quattro		<b>F8-5763</b>		H=90
Control Arm-/Trailing Arm Bush	2.0 E quattro, 2.3 E quattro, 2.8 E quattro		<b>F8-5777</b>		H=23; d=14; D=44
Control Arm-/Trailing Arm Bush	2.0 E 16V quattro, 2.0 E quattro, 2.3 E quattro, 2.6 quattro, 2.8 E quattro, S4 Turbo quattro, S4 V8 quattro		<b>F8-5778</b>		H=25; d=14; D=48
Top Strut Mounting	All Models	ch.4A-N-040000→;	<b>F8-7453</b>		
Control Arm-/Trailing Arm Bush	2.0, 2.0 E, 2.3 E, 2.4 D, 2.5 TDI, 2.6, 2.8 E		<b>G9-617</b>		H=32; d=15; D=55
<b>100 Avant (4A, C4)</b>			<b>12/1990 → 07/1994</b>		
Dust Cover Kit, shock absorber	2.0 E, 2.3 E, 2.4 D, 2.5 TDI, 2.6, 2.8 E		<b>AK-735020</b>		
Dust Cover Kit, shock absorber	2.0 E, 2.3 E, 2.4 D, 2.5 TDI, 2.6, 2.8 E		<b>AK-735125</b>		
Control Arm-/Trailing Arm Bush	2.0 E, 2.0 E quattro, 2.3 E, 2.3 E quattro, 2.4 D, 2.5 TDI, 2.6, 2.6 quattro, 2.8 E, 2.8 E quattro		<b>F8-1024</b>		H1=21; H2=25; d=16; D=63
Mounting, axle bracket	2.0 E, 2.0 E quattro, 2.3 E, 2.3 E quattro, 2.4 D, 2.5 TDI, 2.8 E, 2.8 E quattro	ch.→44-M-050000	<b>F8-3002</b>		H=51; d=12; D1=53; D2=67
Mounting, automatic transmission	2.3 E quattro, 2.6 quattro, 2.8 E quattro, S4 Turbo quattro		<b>F8-3003</b>		H=69; d=11; D=65
Mounting, automatic transmission	2.3 E, 2.4 D, 2.5 TDI, 2.6, 2.8 E	ch.4A-M-000001→	<b>F8-3003</b>		H=69; d=11; D=65
Mounting, automatic transmission	2.3 E, 2.3 E quattro, 2.4 D, 2.5 TDI, 2.6, 2.6 quattro, 2.8 E, 2.8 E quattro	ch.4A-M-000001→	<b>F8-3004</b>		H=69; d=11; D=65
Stabiliser Mounting	2.0 E	01/1993 →;	<b>F8-3006</b>		H=41; d=24; Thick. [mm]=66
Stabiliser Mounting	2.3 E, 2.3 E quattro, 2.4 D, 2.5 TDI, 2.6, 2.6 quattro, 2.8 E, 2.8 E quattro	ch.4A-M-000001→; for OE: 4A0411327A	<b>F8-3006</b>		H=41; d=24; Thick. [mm]=66
Stabiliser Mounting	2.6		<b>F8-3006</b>		H=41; d=24; Thick. [mm]=66
Anti-Friction Bearing	2.0 E, 2.0 E 16V, 2.0 E 16V quattro, 2.0 E quattro, 2.3 E, 2.3 E quattro, 2.4 D, 2.5 TDI, 2.6, 2.6 E quattro, 2.6 quattro, 2.8 E, 2.8 E quattro, S4 Turbo quattro, S4 V8 quattro	ch.4A-N-040000→	<b>F8-3008</b>		H=15; d=91; D=112

<b>AK-735020</b>	<b>AK-735125</b>	<b>F8-1024</b>	<b>F8-3002</b>	<b>F8-3003</b>	<b>F8-3004</b>	<b>F8-3006</b>
Ref.Nr.: <b>AK-735020</b>	Ref.Nr.: <b>4A0512129</b>	Ref.Nr.: <b>4A0407181A</b>	Ref.Nr.: <b>431399419A</b>	Ref.Nr.: <b>4A0399419E</b>	Ref.Nr.: <b>4A0399420E</b>	Ref.Nr.: <b>4A0411327A</b>
<b>F8-3008</b>	<b>F8-3009</b>	<b>F8-5543</b>	<b>F8-5544</b>	<b>F8-5545</b>	<b>F8-5546</b>	<b>F8-5547</b>
Ref.Nr.: <b>4A0412249</b>	Ref.Nr.: <b>4A0412377B</b>	Ref.Nr.: <b>4A0399415</b>	Ref.Nr.: <b>4A0399151C</b>	Ref.Nr.: <b>4A0199379C</b>	Ref.Nr.: <b>4A0199352A</b>	Ref.Nr.: <b>4A0199351B</b>
<b>F8-5763</b>	<b>F8-5777</b>	<b>F8-5778</b>	<b>F8-7453</b>	<b>G9-617</b>		
Ref.Nr.: <b>4A0412131</b>	Ref.Nr.: <b>443511247D</b>	Ref.Nr.: <b>4A0511249</b>	Ref.Nr.: <b>4A0412377A</b>	Ref.Nr.: <b>4A0407183D</b>		

**Article Description****Article Nr.****Fitting Position**

<b>100 Avant (4A, C4)</b>		<b>12/1990 → 07/1994</b>		
Top Strut Mounting	2.0 E, 2.0 E 16V, 2.0 E 16V quattro, 2.0 E quattro, 2.3 E, 2.3 E quattro, 2.4 D, 2.5 TDI, 2.6, 2.6 E quattro, 2.6 quattro, 2.8 E, 2.8 E quattro, S4 Turbo quattro, S4 V8 quattro	ch.4A-N-040000→;	<b>F8-3009</b>	H=41; d=17; D=73
Top Strut Mounting	2.0 E 16V quattro, 2.0 E quattro, 2.3 E quattro, 2.6 quattro, 2.8 E quattro		<b>F8-3010</b>	H=33; d=10; D=79
Top Strut Mounting	2.0 E, 2.0 E 16V, 2.3 E, 2.4 D, 2.5 TDI, 2.6, 2.8 E		<b>F8-3010</b>	H=33; d=10; D=79
Mounting, automatic transmission	2.0 E, 2.0 E quattro		<b>F8-3056</b>	H=70; d=11; D=65
Engine Mounting	2.3 E, 2.3 E quattro, 2.4 D, 2.5 TDI, S4 Turbo quattro		<b>F8-4019</b>	H=47; d=26; D1=48; D2=67
Engine Mounting	2.3 E, 2.3 E quattro, S4 Turbo quattro		<b>F8-4021</b>	H=96; D=114; T [mm]=146
Mounting, automatic transmission	2.0 E		<b>F8-4028</b>	H=42; D=11; D1=50; D2=80; T [mm]=94
Mounting, automatic transmission	2.0 E, 2.0 E quattro, 2.3 E, 2.4 D, 2.5 TDI, 2.8 E		<b>F8-4028</b>	H=42; D=11; D1=50; D2=80; T [mm]=94
Mounting, automatic transmission	2.3 E quattro, 2.8 E quattro		<b>F8-4028</b>	H=42; D=11; D1=50; D2=80; T [mm]=94
Mounting, automatic transmission	2.0 E, 2.0 E quattro, 2.5 TDI		<b>F8-4029</b>	H=125; d=9; Thick. [mm]=55; W=96
Mounting, automatic transmission	2.4 D		<b>F8-4029</b>	H=125; d=9; Thick. [mm]=55; W=96
Protective Cap/Bellow, shock absorber	2.0 E, 2.0 E quattro, 2.3 E, 2.3 E quattro, 2.4 D, 2.5 TDI, 2.6, 2.6 quattro, 2.8 E, 2.8 E quattro, S4 Turbo quattro, S4 V8 quattro		<b>F8-4066</b>	H=105; D1=69; D2=105
Bellow, steering	2.0 E, 2.0 E quattro, 2.3 E, 2.3 E quattro, 2.4 D, 2.5 TDI, 2.6, 2.6 quattro, 2.8 E, 2.8 E quattro, S4 Turbo quattro, S4 V8 quattro		<b>F8-4070</b>	L=530; D1=40; D2=48
Control Arm-/Trailing Arm Bush	2.0 E quattro, 2.3 E quattro, 2.8 E quattro, S4 Turbo quattro	01/1992 →	<b>F8-5306</b>	d=14; D=48; W=25
Control Arm-/Trailing Arm Bush	2.6 quattro, S4 V8 quattro		<b>F8-5306</b>	d=14; D=48; W=25
Mounting, axle beam	2.0 E, 2.3 E, 2.4 D, 2.5 TDI, 2.8 E		<b>F8-5342</b>	
Suspension, panhard rod	2.0 E, 2.3 E, 2.4 D, 2.5 TDI, 2.6, 2.8 E		<b>F8-5344</b>	d=12.2
Mounting, axle beam	2.0 E 16V quattro, 2.0 E quattro, 2.3 E quattro, 2.6 quattro, 2.8 E quattro		<b>F8-5541</b>	d=12; D=58; W=35.8, 58
Mounting, axle bracket	2.0 E 16V, 2.0 E 16V quattro, 2.0 E quattro, 2.3 E quattro, 2.6 quattro, 2.8 E quattro, S4 Turbo quattro, S4 V8 quattro		<b>F8-5543</b>	H=60; D=55
Mounting, axle bracket	2.0 E, 2.3 E, 2.4 D, 2.5 TDI, 2.6, 2.8 E	ch.4A-M-000001→	<b>F8-5543</b>	H=60; D=55
Engine Mounting	2.0 E quattro, 2.3 E quattro, 2.6 quattro, 2.8 E quattro, S4 V8 quattro	Transmission Nr: CBE, CBF, CBL, CDB, CDE, CET, CEZ, CNT	<b>F8-5544</b>	
Engine Mounting	2.0 E, 2.3 E, 2.4 D, 2.5 TDI, 2.6, 2.8 E	Transmission Nr: CDS, CDT, CDU;  4-speed	<b>F8-5544</b>	
Engine Mounting	2.0 E, 2.0 E 16V, 2.0 E 16V quattro, 2.0 E quattro		<b>F8-5545</b>	

<b>F8-3009</b>	<b>F8-3010</b>	<b>F8-3056</b>	<b>F8-4019</b>	<b>F8-4021</b>	<b>F8-4028</b>	<b>F8-4029</b>
Ref.Nr.: 4A0412377B	Ref.Nr.: 443512331	Ref.Nr.: 4A0399420	Ref.Nr.: 893199339	Ref.Nr.: 443199379E	Ref.Nr.: 431399151D	Ref.Nr.: 4A0399151D
<b>F8-4066</b>	<b>F8-4070</b>	<b>F8-5306</b>	<b>F8-5342</b>	<b>F8-5344</b>	<b>F8-5541</b>	<b>F8-5543</b>
Ref.Nr.: 431412175D	Ref.Nr.: 431419831	Ref.Nr.: 4A0511247B	Ref.Nr.: 4A0511247	Ref.Nr.: 431505172	Ref.Nr.: 4D0511523C	Ref.Nr.: 4A0399415
<b>F8-5544</b>	<b>F8-5545</b>	<b>F8-5546</b>				
Ref.Nr.: 4A0399151C	Ref.Nr.: 4A0199379C	Ref.Nr.: 4A0199352A				

Article Description



Article Nr.

Fitting Position



### 100 Avant (4A, C4)

12/1990 → 07/1994

Engine Mounting	2.6, 2.6 quattro, 2.8 E, 2.8 E quattro		F8-5546	⊕	
Engine Mounting	2.6, 2.6 quattro, 2.8 E, 2.8 E quattro		F8-5547	⊕	
Rubber Buffer, suspension	2.0 E, 2.0 E 16V, 2.0 E 16V quattro, 2.0 E quattro, 2.3 E, 2.3 E quattro, 2.4 D, 2.5 TDI, 2.6, 2.6 quattro, 2.8 E, 2.8 E quattro		F8-5763	🚗	H=90
Control Arm-/Trailing Arm Bush	2.0 E quattro, 2.3 E quattro, 2.8 E quattro		F8-5777	🚗 ⊕ ⊕	H=23; d=14; D=44
Control Arm-/Trailing Arm Bush	2.0 E quattro, 2.3 E quattro, 2.6 quattro, 2.8 E quattro, S4 Turbo quattro, S4 V8 quattro		F8-5778	🚗 ⊕ ⊕	H=25; d=14; D=48
Top Strut Mounting	2.0 E, 2.0 E 16V, 2.0 E 16V quattro, 2.0 E quattro, 2.3 E, 2.3 E quattro, 2.4 D, 2.5 TDI, 2.6, 2.6 E quattro, 2.6 quattro, 2.8 E, 2.8 E quattro, S4 Turbo quattro, S4 V8 quattro	ch.4A-N-040000→; 🚗	F8-7453	🚗 ⊕ ⊕	
Control Arm-/Trailing Arm Bush	2.0 E, 2.0 E quattro, 2.3 E, 2.3 E quattro, 2.4 D, 2.5 TDI, 2.6, 2.6 quattro, 2.8 E, 2.8 E quattro		G9-617	🚗 ⊕ ⊕	H=32; d=15; D=55

### 200 (43)

10/1979 → 09/1982

Dust Cover Kit, shock absorber	2.1 5 E, 2.1 5 T		AK-735013	🚗 ⊕ ⊕	
Control Arm-/Trailing Arm Bush	2.1 5 E, 2.1 5 T	ch.43-C-022303→	F8-1017	🚗 ⊕ ⊕	H=23; d=16; D=58
Control Arm-/Trailing Arm Bush	2.1 5 E, 2.1 5 T		F8-1018	🚗 ⊕ ⊕	H1=31; H2=58; d=12; D1=21; D2=46
Mounting, axle beam	2.1 5 E, 2.1 5 T		F8-1019	🚗 ⊕ ⊕	H1=33; H2=43; d=12; D=56
Mounting, axle bracket	2.1 5 E, 2.1 5 T		F8-1022	🚗 ⊕ ⊕	H=57; d=12; D1=46; D2=62
Top Strut Mounting	2.1 5 E, 2.1 5 T	🚗	F8-1023	🚗 ⊕ ⊕	H=26; d=17; D=58
Mounting, axle bracket	2.1 5 E, 2.1 5 T		F8-3002	🚗 ⊕ ⊕	H=51; d=12; D1=53; D2=67
Anti-Friction Bearing	2.1 5 E, 2.1 5 T		F8-3007	🚗	H=15; d=81; D=102
Mounting, radiator	2.1 5 E, 2.1 5 T		F8-4009		H1=15; H2=37; D=39; Outer Thread [mm]=M8 x 1,50
Engine Mounting	2.1 5 E	01/1980 →	F8-4021	⊕ ⊕	H=96; D=114; τ [mm]=146
Engine Mounting	2.1 5 T		F8-4021	⊕	H=96; D=114; τ [mm]=146
Mounting, automatic transmission	2.1 5 E, 2.1 5 T		F8-4028		H=42; D=11; D1=50; D2=80; τ [mm]=94
Bellow, steering	2.1 5 E, 2.1 5 T		F8-4070	🚗	L=530; D1=40; D2=48

### 200 (44, 44Q)

08/1983 → 12/1991

Dust Cover Kit, shock absorber	2.1 Turbo, 2.1 Turbo quattro, 2.2, 2.2 Turbo, 2.2 Turbo quattro		AK-735020	🚗 ⊕ ⊕	
Dust Cover Kit, shock absorber	2.1 5 E, 2.1 Turbo, 2.2, 2.2 Turbo, 2.3		AK-735125	🚗 ⊕ ⊕	
Control Arm-/Trailing Arm Bush	All Models		F8-1017	🚗 ⊕ ⊕	H=23; d=16; D=58
Control Arm-/Trailing Arm Bush	All Models		F8-1018	🚗 ⊕ ⊕	H1=31; H2=58; d=12; D1=21; D2=46

<b>AK-735013</b>	<b>AK-735020</b>	<b>AK-735125</b>	<b>F8-1017</b>	<b>F8-1018</b>	<b>F8-1019</b>	<b>F8-1022</b>
Ref.Nr.:	Ref.Nr.:	Ref.Nr.: 4A0512129	Ref.Nr.: 431407181F	Ref.Nr.: 431407183A	Ref.Nr.: 431511247C	Ref.Nr.: 431399415B
<b>F8-1023</b>	<b>F8-3002</b>	<b>F8-3007</b>	<b>F8-4009</b>	<b>F8-4021</b>	<b>F8-4028</b>	<b>F8-4070</b>
Ref.Nr.: 443412377	Ref.Nr.: 431399419A	Ref.Nr.: 431412249D	Ref.Nr.: 431121273	Ref.Nr.: 443199379E	Ref.Nr.: 431399151D	Ref.Nr.: 431419831
<b>F8-5546</b>	<b>F8-5547</b>	<b>F8-5763</b>	<b>F8-5777</b>	<b>F8-5778</b>	<b>F8-7453</b>	<b>G9-617</b>
Ref.Nr.: 4A0199352A	Ref.Nr.: 4A0199351B	Ref.Nr.: 4A0412131	Ref.Nr.: 443511247D	Ref.Nr.: 4A0511249	Ref.Nr.: 4A0412377A	Ref.Nr.: 4A0407183D



**Article Description****Article Nr.****Fitting Position**

<b>200 (44, 44Q)</b>			<b>08/1983 → 12/1991</b>		
Mounting, axle beam	2.1 5 E, 2.1 Turbo, 2.2, 2.2 Turbo, 2.3		<b>F8-1019</b>		H1=33; H2=43; d=12; D=56
Engine Mounting	2.1 5 E	01/1984 →	<b>F8-1020</b>		H=97; D=114; T [mm]=145
Engine Mounting	2.1 Turbo, 2.1 Turbo quattro, 2.2, 2.2 Turbo, 2.2 Turbo quattro		<b>F8-1020</b>		H=97; D=114; T [mm]=145
Engine Mounting	2.1 5 E	01/1984 →; *	<b>F8-1021</b>		H=97; D=114; T [mm]=143
Engine Mounting	2.1 Turbo, 2.1 Turbo quattro, 2.2, 2.2 Turbo, 2.2 Turbo quattro	ch.44-F-000237 →; *	<b>F8-1021</b>		H=97; D=114; T [mm]=143
Mounting, axle bracket	All Models		<b>F8-1022</b>		H=57; d=12; D1=46; D2=62
Top Strut Mounting	2.1 5 E, 2.1 Turbo, 2.1 Turbo quattro, 2.2, 2.2 Turbo, 2.2 Turbo quattro		<b>F8-1023</b>		H=26; d=17; D=58
Mounting, axle bracket	2.1 5 E, 2.1 Turbo, 2.1 Turbo quattro, 2.2, 2.2 20V Turbo quattro, 2.2 Turbo, 2.2 Turbo quattro		<b>F8-3002</b>		H=51; d=12; D1=53; D2=67
Mounting, axle bracket	2.2 Turbo	ch.→44-M-050000	<b>F8-3002</b>		H=51; d=12; D1=53; D2=67
Stabiliser Mounting	2.1 5 E, 2.1 Turbo quattro, 2.2, 2.2 20V Turbo quattro, 2.2 Turbo quattro, 2.3	ch.→44-M-050000; for OE: 443 411 327	<b>F8-3005</b>		H=45; d=20; W=46
Stabiliser Mounting	2.1 Turbo, 2.2 Turbo	ch.44-H-180001 →; ch.→44-M-050000; for OE: 443 411 327	<b>F8-3005</b>		H=45; d=20; W=46
Anti-Friction Bearing	All Models		<b>F8-3007</b>		H=15; d=81; D=102
Top Strut Mounting	2.1 5 E	01/1984 →; II	<b>F8-3010</b>		H=33; d=10; D=79
Top Strut Mounting	2.1 Turbo, 2.1 Turbo quattro, 2.2, 2.2 20V Turbo quattro, 2.2 Turbo, 2.2 Turbo quattro		<b>F8-3010</b>		H=33; d=10; D=79
Mounting, radiator	All Models		<b>F8-4009</b>		H1=15; H2=37; D=39; Outer Thread [mm]=M8 x 1,50
Engine Mounting	2.2 20V Turbo quattro	*	<b>F8-4019</b>		H=47; d=26; D1=48; D2=67
Rubber Buffer, silencer	2.2 Turbo quattro		<b>F8-4026</b>		H=12; W=57, 60
Mounting, automatic transmission	2.1 5 E, 2.1 Turbo, 2.2, 2.2 Turbo, 2.2 Turbo quattro		<b>F8-4028</b>		H=42; D=11; D1=50; D2=80; T [mm]=94
Mounting, automatic transmission	2.1 Turbo quattro, 2.2 20V Turbo quattro		<b>F8-4028</b>		H=42; D=11; D1=50; D2=80; T [mm]=94
Protective Cap/Bellow, shock absorber	2.1 Turbo, 2.1 Turbo quattro, 2.2	01/1985 →	<b>F8-4066</b>		H=105; D1=69; D2=105
Protective Cap/Bellow, shock absorber	2.2 20V Turbo quattro, 2.2 Turbo, 2.2 Turbo quattro		<b>F8-4066</b>		H=105; D1=69; D2=105
Bellow, steering	All Models		<b>F8-4070</b>		L=530; D1=40; D2=48
Suspension, panhard rod	2.1 5 E, 2.1 Turbo, 2.2, 2.2 Turbo		<b>F8-5344</b>		d=12.2
Mounting, axle beam	2.1 Turbo quattro, 2.2 Turbo quattro	ch.44-G-073363 →; 01/1986 →	<b>F8-5541</b>		d=12; D=58; W=35.8, 58
Mounting, axle beam	2.2 20V Turbo quattro, 2.2 Turbo quattro	ch.44-G-073363 →	<b>F8-5541</b>		d=12; D=58; W=35.8, 58
Control Arm-/Trailing Arm Bush	2.1 Turbo quattro, 2.2 20V Turbo quattro, 2.2 Turbo quattro		<b>F8-5777</b>		H=23; d=14; D=44
Control Arm-/Trailing Arm Bush	2.2 20V Turbo quattro, 2.2 Turbo quattro		<b>F8-5778</b>		H=25; d=14; D=48

<b>F8-1019</b>	<b>F8-1020</b>	<b>F8-1021</b>	<b>F8-1022</b>	<b>F8-1023</b>	<b>F8-3002</b>	<b>F8-3005</b>
Ref.Nr.: 431511247C	Ref.Nr.: 443199379	Ref.Nr.: 443199382	Ref.Nr.: 431399415B	Ref.Nr.: 443412377	Ref.Nr.: 431399419A	Ref.Nr.: 443411327
<b>F8-3007</b>	<b>F8-3010</b>	<b>F8-4009</b>	<b>F8-4019</b>	<b>F8-4026</b>	<b>F8-4028</b>	<b>F8-4066</b>
Ref.Nr.: 431412249D	Ref.Nr.: 443512331	Ref.Nr.: 431121273	Ref.Nr.: 893199339	Ref.Nr.: 817253147	Ref.Nr.: 431399151D	Ref.Nr.: 431412175D
<b>F8-4070</b>	<b>F8-5344</b>	<b>F8-5541</b>	<b>F8-5777</b>	<b>F8-5778</b>		
Ref.Nr.: 431419831	Ref.Nr.: 431505172	Ref.Nr.: 4D0511523C	Ref.Nr.: 443511247D	Ref.Nr.: 4A0511249		

Article Description			Article Nr.	Fitting Position	
---------------------	--	--	-------------	------------------	--

<b>200 Avant (44, 44Q)</b>			<b>09/1983 → 12/1991</b>		
Dust Cover Kit, shock absorber	2.2 Turbo		<b>AK-735020</b>		
Dust Cover Kit, shock absorber	2.2 Turbo, 2.3		<b>AK-735125</b>		
Control Arm-/Trailing Arm Bush	All Models		<b>F8-1017</b>		H=23; d=16; D=58
Control Arm-/Trailing Arm Bush	All Models		<b>F8-1018</b>		H1=31; H2=58; d=12; D1=21; D2=46
Mounting, axle beam	2.2 Turbo, 2.3		<b>F8-1019</b>		H1=33; H2=43; d=12; D=56
Engine Mounting	2.1 Turbo quattro, 2.2 Turbo quattro		<b>F8-1020</b>		H=97; D=114; T [mm]=145
Engine Mounting	2.1 Turbo quattro, 2.2 Turbo quattro	ch.44-F-000237→; *	<b>F8-1021</b>		H=97; D=114; T [mm]=143
Mounting, axle bracket	All Models		<b>F8-1022</b>		H=57; d=12; D1=46; D2=62
Top Strut Mounting	2.1 Turbo quattro, 2.2 Turbo quattro		<b>F8-1023</b>		H=26; d=17; D=58
Mounting, axle bracket	2.1 Turbo quattro, 2.2 20V Turbo quattro, 2.2 Turbo quattro		<b>F8-3002</b>		H=51; d=12; D1=53; D2=67
Stabiliser Mounting	All Models	ch.→44-M-050000; for OE: 443 411 327	<b>F8-3005</b>		H=45; d=20; W=46
Anti-Friction Bearing	All Models		<b>F8-3007</b>		H=15; d=81; D=102
Top Strut Mounting	2.1 Turbo quattro, 2.2 20V Turbo quattro, 2.2 Turbo, 2.2 Turbo quattro		<b>F8-3010</b>		H=33; d=10; D=79
Mounting, radiator	2.1 Turbo quattro	KG	<b>F8-4009</b>		H1=15; H2=37; D=39; Outer Thread [mm]=M8 x 1,50
Mounting, radiator	2.2 20V Turbo quattro, 2.2 Turbo, 2.2 Turbo quattro, 2.3		<b>F8-4009</b>		H1=15; H2=37; D=39; Outer Thread [mm]=M8 x 1,50
Mounting, radiator	2.1 Turbo quattro, 2.2 20V Turbo quattro, 2.2 Turbo quattro		<b>F8-4011</b>		H1=16; H2=38; D=30; Outer Thread [mm]=M8 x 1,25
Engine Mounting	2.2 20V Turbo quattro	*	<b>F8-4019</b>		H=47; d=26; D1=48; D2=67
Mounting, automatic transmission	2.1 Turbo quattro, 2.2 Turbo quattro		<b>F8-4028</b>		H=42; D=11; D1=50; D2=80; T [mm]=94
Mounting, automatic transmission	2.2 20V Turbo quattro		<b>F8-4028</b>		H=42; D=11; D1=50; D2=80; T [mm]=94
Protective Cap/Bellow, shock absorber	2.1 Turbo quattro, 2.2 Turbo quattro	01/1985 →	<b>F8-4066</b>		H=105; D1=69; D2=105
Protective Cap/Bellow, shock absorber	2.2 20V Turbo quattro, 2.2 Turbo quattro		<b>F8-4066</b>		H=105; D1=69; D2=105
Bellow, steering	All Models		<b>F8-4070</b>		L=530; D1=40; D2=48
Mounting, axle beam	2.1 Turbo quattro, 2.2 Turbo quattro	ch.44-G-073363→; 01/1986 →	<b>F8-5541</b>		d=12; D=58; W=35.8, 58
Mounting, axle beam	2.2 20V Turbo quattro, 2.2 Turbo quattro	ch.44-G-073363→	<b>F8-5541</b>		d=12; D=58; W=35.8, 58
Control Arm-/Trailing Arm Bush	2.1 Turbo quattro, 2.2 20V Turbo quattro, 2.2 Turbo quattro		<b>F8-5777</b>		H=23; d=14; D=44
Control Arm-/Trailing Arm Bush	2.2 20V Turbo quattro, 2.2 Turbo quattro		<b>F8-5778</b>		H=25; d=14; D=48
<b>A1 (8X1, 8XK, 8XF)</b>			<b>05/2010 →</b>		
Dust Cover Kit, shock absorber	1.2 TFSI, 1.4 TFSI, 1.6 TDI, 2.0 TDI		<b>AK-735410</b>		H=210

<b>AK-735020</b>	<b>AK-735125</b>	<b>AK-735410</b>	<b>F5-1004</b>	<b>F8-1017</b>	<b>F8-1018</b>	<b>F8-1019</b>
Ref.Nr.:	Ref.Nr.: 4A0512129	Ref.Nr.: 1J0412303	Ref.Nr.: 038903119T	Ref.Nr.: 431407181F	Ref.Nr.: 431407183A	Ref.Nr.: 431511247C
<b>F8-1020</b>	<b>F8-1021</b>	<b>F8-1022</b>	<b>F8-1023</b>	<b>F8-3002</b>	<b>F8-3005</b>	<b>F8-3007</b>
Ref.Nr.: 443199379	Ref.Nr.: 443199382	Ref.Nr.: 431399415B	Ref.Nr.: 443412377	Ref.Nr.: 431399419A	Ref.Nr.: 443411327	Ref.Nr.: 431412249D
<b>F8-3010</b>	<b>F8-4009</b>	<b>F8-4011</b>	<b>F8-4019</b>	<b>F8-4028</b>	<b>F8-4066</b>	<b>F8-4070</b>
Ref.Nr.: 443512331	Ref.Nr.: 431121273	Ref.Nr.: 803121273	Ref.Nr.: 893199339	Ref.Nr.: 431399151D	Ref.Nr.: 431412175D	Ref.Nr.: 431419831

**Article Description****Article Nr.****Fitting Position**

<b>A1 (8X1, 8XK, 8XF)</b>				<b>05/2010 →</b>	
Alternator Freewheel Clutch	1.6 TDI, 2.0 TDI, 2.0 TFSI quattro		<b>F5-1004</b>		
Alternator Freewheel Clutch	1.2 TFSI, 1.4 TFSI		<b>F5-1064</b>		
Anti-Friction Bearing	1.2 TFSI, 1.4 TFSI, 1.6 TDI, 2.0 TDI, 2.0 TFSI quattro		<b>F8-3039</b>		H=14; d1=14; D=45
Top Strut Mounting	1.2 TFSI, 1.4 TFSI, 1.6 TDI, 2.0 TDI, 2.0 TFSI quattro		<b>F8-4067</b>		H=53; d=26; D=82
Top Strut Mounting	1.2 TFSI, 1.4 TFSI, 1.6 TDI, 2.0 TDI	07/2013 →	<b>F8-5380</b>		
Rubber Buffer, suspension	1.2 TFSI, 1.4 TFSI, 1.6 TDI, 2.0 TDI		<b>F8-5381</b>		H=37; D=76
Protective Cap/Bellow, shock absorber	1.2 TFSI, 1.4 TFSI, 1.6 TDI, 2.0 TDI		<b>F8-5683</b>		H=210
Rubber Buffer, suspension	1.2 TFSI, 1.4 TFSI, 1.6 TDI, 2.0 TDI, 2.0 TFSI quattro	for OE: G31, G32;	<b>F8-5993</b>		H=83
Rubber Buffer, suspension	1.2 TFSI, 1.4 TFSI, 1.6 TDI, 2.0 TDI	for OE: G26, G27;	<b>F8-5996</b>		H=63
Rubber Buffer, suspension	1.2 TFSI, 1.4 TFSI, 1.6 TDI, 2.0 TDI	S line; for OE: G28, G29	<b>F8-5996</b>		H=63
Rubber Buffer, suspension	1.2 TFSI, 1.4 TFSI, 1.6 TDI, 2.0 TDI, 2.0 TFSI quattro	for OE: G22, G23;	<b>F8-5996</b>		H=63
Top Strut Mounting	1.2 TFSI, 1.4 TFSI, 1.6 TDI, 2.0 TDI		<b>F8-6040</b>		
Protective Cap/Bellow, shock absorber	1.2 TFSI, 1.4 TFSI, 1.6 TDI, 2.0 TDI		<b>F8-6044</b>		H=160
Top Strut Mounting	1.2 TFSI, 1.4 TFSI, 1.6 TDI, 2.0 TDI, 2.0 TFSI quattro		<b>F8-6280</b>		H=53; d=26; D=82
Belt Pulley, crankshaft	1.6 TDI, 2.0 TDI	Number of Ribs: 5; Parameter: 6PK	<b>F8-6572</b>		
Rubber Buffer, suspension	1.2 TFSI, 1.4 TFSI, 1.6 TDI, 2.0 TDI	for OE: 1JB;	<b>F8-6723</b>		H=124
Top Strut Mounting	1.2 TFSI, 1.4 TFSI, 1.6 TDI, 2.0 TDI, 2.0 TFSI quattro	for OE: 1J0412319C	<b>F8-7133</b>		
Rubber Buffer, suspension	2.0 TFSI quattro		<b>F8-7140</b>		H=133
Rubber Buffer, suspension	1.2 TFSI, 1.4 TFSI, 1.6 TDI, 2.0 TDI	for OE: UC0, UC2, UC3; Shape Round;	<b>F8-7601</b>		H=118
Top Strut Mounting	2.0 TFSI quattro		<b>F8-7603</b>		
Protective Cap/Bellow, shock absorber	2.0 TFSI quattro		<b>F8-7627</b>		H=178
Engine Mounting	1.2 TFSI		<b>F8-7951</b>		
Engine Mounting	1.6 TDI		<b>F8-7957</b>		
Control Arm-/Trailing Arm Bush	1.2 TFSI, 1.4 TFSI, 1.6 TDI, 2.0 TDI, 2.0 TFSI quattro		<b>F8-7978</b>		
Engine Mounting	1.0 TFSI		<b>F8-8164</b>		
Engine Mounting	1.2 TFSI, 1.6 TDI	7-speed	<b>F8-8173</b>		
Engine Mounting	1.4 TFSI	CAXA;  7-speed	<b>F8-8173</b>		
Control Arm-/Trailing Arm Bush	1.2 TFSI	12/2010 →;	<b>G9-649</b>		H1=25; H2=41; d=13; D=60
Control Arm-/Trailing Arm Bush	1.2 TFSI, 1.4 TFSI, 1.6 TDI, 2.0 TDI, 2.0 TFSI quattro		<b>G9-649</b>		H1=25; H2=41; d=13; D=60
Control Arm-/Trailing Arm Bush	1.6 TDI	07/2010 →;	<b>G9-649</b>		H1=25; H2=41; d=13; D=60

<b>F5-1004</b>	<b>F5-1064</b>	<b>F8-3039</b>	<b>F8-4067</b>	<b>F8-5380</b>	<b>F8-5381</b>	<b>F8-5683</b>
Ref.Nr.: 038903119T	Ref.Nr.: 03C903119D	Ref.Nr.: 357412249A	Ref.Nr.: 1J0412331B	Ref.Nr.: 1J0513353G	Ref.Nr.: 1J0512149B	Ref.Nr.: 357413175A
<b>F8-5993</b>	<b>F8-5996</b>	<b>F8-6040</b>	<b>F8-6044</b>	<b>F8-6280</b>	<b>F8-6572</b>	<b>F8-6723</b>
Ref.Nr.: 357412303F	Ref.Nr.: 1H0412303B	Ref.Nr.: 1J0513353D	Ref.Nr.: 3C0513425	Ref.Nr.: 6R0412249	Ref.Nr.: 038105243L	Ref.Nr.: 6Q0512131B
<b>F8-7133</b>	<b>F8-7140</b>	<b>F8-7601</b>	<b>F8-7603</b>	<b>F8-7627</b>	<b>F8-7951</b>	<b>F8-7957</b>
Ref.Nr.: 1J0412319C	Ref.Nr.: 3C0511359	Ref.Nr.: 1K0511353N	Ref.Nr.: 3C0513353	Ref.Nr.: 1K0513425D	Ref.Nr.: 6Q0199555AR	Ref.Nr.: 6R0199555

<b>Article Description</b>			<b>Article Nr.</b>	<b>Fitting Position</b>	
----------------------------	--	--	--------------------	-------------------------	--

<b>A1 (8X1, 8XK, 8XF)</b>			<b>05/2010 →</b>		
Control Arm-/Trailing Arm Bush	1.6 TDI, 2.0 TDI	<b>SP</b>	<b>G9-649</b>		H1=25; H2=41; d=13; D=60
<b>A1 Sportback (8XA, 8XF, 8XK)</b>			<b>09/2011 →</b>		
Dust Cover Kit, shock absorber	1.2 TFSI, 1.4 TFSI, 1.6 TDI, 2.0 TDI	<b>ST</b>	<b>AK-735410</b>		H=210
Alternator Freewheel Clutch	1.6 TDI, 2.0 TDI		<b>F5-1004</b>		
Alternator Freewheel Clutch	1.2 TFSI, 1.4 TFSI		<b>F5-1064</b>		
Anti-Friction Bearing	1.2 TFSI, 1.4 TFSI, 1.6 TDI, 2.0 TDI		<b>F8-3039</b>		H=14; d1=14; D=45
Top Strut Mounting	1.2 TFSI, 1.4 TFSI, 1.6 TDI, 2.0 TDI		<b>F8-4067</b>		H=53; d=26; D=82
Top Strut Mounting	1.2 TFSI, 1.4 TFSI, 1.6 TDI, 2.0 TDI	07/2013 →	<b>F8-5380</b>		
Rubber Buffer, suspension	1.2 TFSI, 1.4 TFSI, 1.6 TDI, 2.0 TDI		<b>F8-5381</b>		H=37; D=76
Protective Cap/Bellow, shock absorber	1.2 TFSI, 1.4 TFSI, 1.6 TDI, 2.0 TDI		<b>F8-5683</b>		H=210
Rubber Buffer, suspension	1.2 TFSI, 1.4 TFSI, 1.6 TDI, 2.0 TDI	for OE: G31, G32; <b>Δ</b>	<b>F8-5993</b>		H=83
Rubber Buffer, suspension	1.2 TFSI, 1.4 TFSI, 1.6 TDI, 2.0 TDI	for OE: G22, G23; <b>ST</b>	<b>F8-5996</b>		H=63
Rubber Buffer, suspension	1.2 TFSI, 1.4 TFSI, 1.6 TDI, 2.0 TDI	for OE: G26, G27; <b>SP</b>	<b>F8-5996</b>		H=63
Rubber Buffer, suspension	1.2 TFSI, 1.4 TFSI, 1.6 TDI, 2.0 TDI	S line; for OE: G28, G29	<b>F8-5996</b>		H=63
Top Strut Mounting	1.2 TFSI, 1.4 TFSI, 1.6 TDI, 2.0 TDI		<b>F8-6040</b>		
Protective Cap/Bellow, shock absorber	1.2 TFSI, 1.4 TFSI, 1.6 TDI, 2.0 TDI		<b>F8-6044</b>		H=160
Top Strut Mounting	1.2 TFSI, 1.4 TFSI, 1.6 TDI, 2.0 TDI		<b>F8-6280</b>		H=53; d=26; D=82
Belt Pulley, crankshaft	1.6 TDI, 2.0 TDI	Number of Ribs: 5; Parameter: 6PK	<b>F8-6572</b>		
Rubber Buffer, suspension	1.2 TFSI, 1.4 TFSI, 1.6 TDI, 2.0 TDI	for OE: 1JB; <b>Δ</b>	<b>F8-6723</b>		H=124
Top Strut Mounting	1.2 TFSI, 1.4 TFSI, 1.6 TDI, 2.0 TDI	for OE: 1J0412319C	<b>F8-7133</b>		
Rubber Buffer, suspension	1.2 TFSI, 1.4 TFSI, 1.6 TDI, 2.0 TDI	for OE: UC0, UC2, UC3; Shape Round; <b>SP, ST</b>	<b>F8-7601</b>		H=118
Engine Mounting	1.2 TFSI		<b>F8-7951</b>		
Engine Mounting	1.6 TDI		<b>F8-7957</b>		
Control Arm-/Trailing Arm Bush	1.2 TFSI, 1.4 TFSI, 1.6 TDI, 2.0 TDI		<b>F8-7978</b>		
Engine Mounting	1.0 TFSI		<b>F8-8164</b>		
Control Arm-/Trailing Arm Bush	1.2 TFSI, 1.4 TFSI, 1.6 TDI, 2.0 TDI	<b>Δ, ST</b>	<b>G9-649</b>		H1=25; H2=41; d=13; D=60
<b>A2 (8Z0)</b>			<b>02/2000 → 08/2005</b>		
Dust Cover Kit, shock absorber	All Models		<b>AK-735004</b>		
Dust Cover Kit, shock absorber	All Models		<b>AK-735095</b>		
Alternator Freewheel Clutch	1.2 TDI, 1.4 TDI		<b>F5-1004</b>		
Rubber Buffer, suspension	All Models		<b>F8-5381</b>		H=37; D=76

<b>AK-735004</b>	<b>AK-735095</b>	<b>AK-735410</b>	<b>F5-1004</b>	<b>F5-1064</b>	<b>F8-3039</b>	<b>F8-4067</b>
Ref.Nr.:	Ref.Nr.: 1J0512131B	Ref.Nr.: 1J0412303	Ref.Nr.: 038903119T	Ref.Nr.: 03C903119D	Ref.Nr.: 357412249A	Ref.Nr.: 1J0412331B
<b>F8-5380</b>	<b>F8-5381</b>	<b>F8-5526</b>	<b>F8-5683</b>	<b>F8-5993</b>	<b>F8-5996</b>	<b>F8-6040</b>
Ref.Nr.: 1J0513353G	Ref.Nr.: 1J0512149B	Ref.Nr.: 8D0121275	Ref.Nr.: 357413175A	Ref.Nr.: 357412303F	Ref.Nr.: 1H0412303B	Ref.Nr.: 1J0513353D
<b>F8-6044</b>	<b>F8-6280</b>	<b>F8-6572</b>	<b>F8-6723</b>	<b>F8-7133</b>	<b>F8-7601</b>	<b>F8-7951</b>
Ref.Nr.: 3C0513425	Ref.Nr.: 6R0412249	Ref.Nr.: 038105243L	Ref.Nr.: 6Q0512131B	Ref.Nr.: 1J0412319C	Ref.Nr.: 1K0511353N	Ref.Nr.: 6Q0199555AR

**Article Description****Article Nr.****Fitting Position**

<b>A2 (8Z0)</b>			<b>02/2000 → 08/2005</b>		
Mounting, radiator	1.2 TDI, 1.4, 1.4 TDI, 1.6 FSI		<b>F8-5526</b>		d=15; D=40; Thick. [mm]=25
Top Strut Mounting	All Models		<b>F8-5537</b>		
Top Strut Mounting	All Models		<b>F8-6040</b>		
Protective Cap/Bellow, shock absorber	1.2 TDI, 1.4, 1.4 TDI		<b>F8-6045</b>		
Top Strut Mounting	All Models		<b>F8-6281</b>		
Stabiliser Mounting	All Models	for OE: 8Z0411305M; Stabi. Diam. [mm]= 18	<b>F8-6462</b>		d=16
Anti-Friction Bearing	All Models		<b>F8-6569</b>		
Rubber Buffer, suspension	All Models	not for PR: G22	<b>F8-6723</b>		H=124
Engine Mounting	1.4, 1.6 FSI	ch.8Z-5-000 001→	<b>F8-6946</b>		
Engine Mounting	1.4 TDI		<b>F8-6947</b>		
Engine Mounting	1.4 TDI	ch.8Z-4-012701→;  BHC	<b>F8-6947</b>		
Engine Mounting	1.2 TDI	ch.8Z-5-000 001→	<b>F8-6948</b>		
Protective Cap/Bellow, shock absorber	All Models		<b>F8-7132</b>		H=190
Control Arm-/Trailing Arm Bush	1.4, 1.6 FSI	Aluminium	<b>F8-7447</b>		d1=18; d2=20; D=62; W=41
Control Arm-/Trailing Arm Bush	1.4 TDI	Aluminium	<b>F8-7448</b>		d1=18; d2=20; D=62; W=41
Rubber Buffer, suspension	1.2 TDI		<b>F8-7676</b>		H=56
Stabiliser Mounting	1.4, 1.4 TDI, 1.6 FSI		<b>F8-7914</b>		d=20,8
Belt Pulley, crankshaft	1.4 TDI	Number of Ribs: 5; Parameter: 6PK	<b>F8-8038</b>		
<b>A3 (8L1)</b>			<b>09/1996 → 05/2003</b>		
Dust Cover Kit, shock absorber	All Models		<b>AK-735039</b>		
Dust Cover Kit, shock absorber	1.6, 1.8, 1.8 T, 1.9 TDI		<b>AK-735095</b>		
Dust Cover Kit, shock absorber	All Models		<b>AK-735410</b>		H=210
Alternator Freewheel Clutch	All Models		<b>F5-1004</b>		
Alternator Freewheel Clutch	1.9 TDI		<b>F5-1009</b>		
Anti-Friction Bearing	All Models		<b>F8-3039</b>		H=14; d1=14; D=45
Top Strut Mounting	All Models		<b>F8-4067</b>		H=53; d=26; D=82
Bellow Set, steering	1.6, 1.8, 1.8 T, 1.8 T quattro, 1.9 TDI, S3 quattro	for OE: 1J0422831	<b>F8-4074</b>		H=125; D1=34; D2=39
Stabiliser Mounting	1.6, 1.9 TDI	01/2001 →; only in connection with: F8-6579; Stabi. Diam. [mm]= 19	<b>F8-5215</b>		d=17
Stabiliser Mounting	1.8	01/2001 →;  APG; only in connection with: F8-6579; Stabi. Diam. [mm]= 19	<b>F8-5215</b>		d=17
Stabiliser Mounting	1.8 T	01/2001 →;  AQA, AUM; only in connection with: F8-6579; Stabi. Diam. [mm]= 19	<b>F8-5215</b>		d=17

<b>AK-735039</b>	<b>AK-735095</b>	<b>AK-735410</b>	<b>F5-1004</b>	<b>F5-1009</b>	<b>F8-3039</b>	<b>F8-4067</b>
Ref.Nr.: 357413175A	Ref.Nr.: 1J0512131B	Ref.Nr.: 1J0412303	Ref.Nr.: 038903119T	Ref.Nr.: 038903119	Ref.Nr.: 357412249A	Ref.Nr.: 1J0412331B
<b>F8-4074</b>	<b>F8-5215</b>	<b>F8-5526</b>	<b>F8-5537</b>	<b>F8-6040</b>	<b>F8-6045</b>	<b>F8-6281</b>
Ref.Nr.: 171419832A	Ref.Nr.: 1J0411314B	Ref.Nr.: 8D0121275	Ref.Nr.: 6N0412331E	Ref.Nr.: 1J0513353D	Ref.Nr.: 1J0513425A	Ref.Nr.: 8Z0412331
<b>F8-6462</b>	<b>F8-6569</b>	<b>F8-6723</b>	<b>F8-6946</b>	<b>F8-6947</b>	<b>F8-6948</b>	<b>F8-7132</b>
Ref.Nr.: 6Q0411314L	Ref.Nr.: 6N0412249C	Ref.Nr.: 6Q0512131B	Ref.Nr.: 8Z0199167AS	Ref.Nr.: 8Z0199167AQ	Ref.Nr.: 8Z0199167AR	Ref.Nr.: 6N0413175A

**Article Description**

**Article Nr.**
**Fitting Position**

<b>A3 (8L1)</b>			<b>09/1996 → 05/2003</b>		
Stabiliser Mounting	1.8 T	AJQ, ARY, AUQ; only in connection with: F8-6579; Stabi. Diam. [mm]= 19	<b>F8-5215</b>		d=17
Stabiliser Mounting	1.8 T quattro	01/1997 →;  AGU, AQA; only in connection with: F8-6579; Stabi. Diam. [mm]= 19	<b>F8-5215</b>		d=17
Stabiliser Mounting	1.8 T quattro	AJQ; only in connection with: F8-6579; Stabi. Diam. [mm]= 19	<b>F8-5215</b>		d=17
Stabiliser Mounting	1.9 TDI	01/2001 →;  AHF; only in connection with: F8-6579; Stabi. Diam. [mm]= 19	<b>F8-5215</b>		d=17
Stabiliser Mounting	1.6, 1.8, 1.8 T, 1.9 TDI	only in connection with: F8-6579; Stabi. Diam. [mm]= 21	<b>F8-5221</b>	⊕ ⊕	d=19; D=20.7
Stabiliser Mounting	1.8 T quattro, 1.9 TDI quattro	ch.8L-X-140000→; only in connection with: F8-6579; Stabi. Diam. [mm]= 21	<b>F8-5221</b>	⊕ ⊕	d=19; D=20.7
Mounting, axle beam	1.6, 1.8, 1.8 T, 1.8 T quattro, 1.9 TDI		<b>F8-5340</b>	⊕ ⊕	H=90; d=12; D=72
Top Strut Mounting	1.6, 1.8, 1.8 T, 1.9 TDI		<b>F8-5380</b>	⊕ ⊕	
Rubber Buffer, suspension	1.6, 1.8, 1.8 T, 1.9 TDI		<b>F8-5381</b>	⊕ ⊕ ⊕ ↑	H=37; D=76
Stabiliser Mounting	All Models		<b>F8-5382</b>	⊕ ⊕ ⊕	D=14
Engine Mounting	1.6, 1.8, 1.8 T, 1.8 T quattro		<b>F8-5383</b>		
Mounting, manual transmission	1.6		<b>F8-5385</b>	⊕	
Engine Mounting	1.6		<b>F8-5386</b>	⊕	
Engine Mounting	1.8, 1.8 T, 1.8 T quattro, 1.9 TDI		<b>F8-5386</b>	⊕	
Mounting, automatic transmission	1.8 T quattro		<b>F8-5387</b>	⊕	
Mounting, automatic transmission	1.8, 1.8 T, 1.8 T quattro, 1.9 TDI		<b>F8-5387</b>	⊕	
Mounting, automatic transmission	S3 quattro	ch.→8L-Y-013167	<b>F8-5387</b>	⊕	
Engine Mounting	1.6		<b>F8-5390</b>	⊕	
Engine Mounting	1.8 T	5-speed	<b>F8-5404</b>	⊕	
Engine Mounting	1.8, 1.8 T quattro, 1.9 TDI		<b>F8-5404</b>	⊕	
Engine Mounting	1.9 TDI	01/2001 →	<b>F8-5404</b>	⊕	
Spring Cap	All Models		<b>F8-5580</b>	⊕ ⊕ ⊕ ↑	D=92
Belt Pulley, crankshaft	1.8, 1.8 T, 1.8 T quattro		<b>F8-5650</b>		
Protective Cap/Bellow, shock absorber	All Models		<b>F8-5683</b>	⊕ ⊕	H=210
Mounting, axle beam	All Models		<b>F8-5907</b>	⊕ ⊕	H=31; d1=18; d2=19; D1=65; D2=56
Rubber Buffer, suspension	1.6, 1.8, 1.8 T, 1.9 TDI	for OE: 1GE, 1GJ, G01, G02, G65;	<b>F8-5996</b>	⊕ ⊕	H=63
Rubber Buffer, suspension	1.6, 1.8, 1.8 T, 1.9 TDI	for OE: 1GN, G05;	<b>F8-5996</b>	⊕ ⊕	H=63
Rubber Buffer, suspension	1.8 T quattro, 1.9 TDI quattro	for OE: 1GF, 1GJ, G42, G68;	<b>F8-5996</b>	⊕ ⊕	H=63

<b>F8-5215</b>	<b>F8-5221</b>	<b>F8-5340</b>	<b>F8-5380</b>	<b>F8-5381</b>	<b>F8-5382</b>	<b>F8-5383</b>
Ref.Nr.: 1J0411314B	Ref.Nr.: 1J0411314R	Ref.Nr.: 6R0501541A	Ref.Nr.: 1J0513353G	Ref.Nr.: 1J0512149B	Ref.Nr.: 1J0411327	Ref.Nr.: 1J0199851AA
<b>F8-5385</b>	<b>F8-5386</b>	<b>F8-5387</b>	<b>F8-5390</b>	<b>F8-5404</b>	<b>F8-5580</b>	<b>F8-5650</b>
Ref.Nr.: 1J0199555AK	Ref.Nr.: 1J0199555AJ	Ref.Nr.: 1J0199555AH	Ref.Nr.: 1J0199262BE	Ref.Nr.: 1J0199262BF	Ref.Nr.: 1J0412341	Ref.Nr.: 06A105243E
<b>F8-5683</b>	<b>F8-5907</b>	<b>F8-5996</b>				
Ref.Nr.: 357413175A	Ref.Nr.: 1J0199429	Ref.Nr.: 1H0412303B				

**Article Description****Article Nr.****Fitting Position**

<b>A3 (8L1)</b>			<b>09/1996 → 05/2003</b>		
Rubber Buffer, suspension	1.8 T quattro, 1.9 TDI quattro	for OE: G89;	<b>F8-5996</b>		H=63
Rubber Buffer, suspension	S3 quattro	for OE: G93;	<b>F8-5996</b>		H=63
Rubber Buffer, suspension	1.6, 1.8, 1.8 T, 1.8 T quattro, 1.9 TDI		<b>F8-6007</b>		H=116
Rubber Buffer, suspension	All Models		<b>F8-6012</b>		H=143
Rubber Buffer, suspension	1.6, 1.8, 1.8 T, 1.8 T quattro, 1.9 TDI		<b>F8-6013</b>		H=128
Rubber Buffer, suspension	1.6, 1.8, 1.8 T, 1.9 TDI	for OE: 1GK, 1GL, G03, G66, G94;	<b>F8-6041</b>		H=53
Rubber Buffer, suspension	1.8 T quattro, 1.9 TDI quattro	for OE: 1GK, 1GL, 1GX, G43, G69, G95;	<b>F8-6041</b>		H=53
Rubber Buffer, suspension	S3 quattro	for OE: 1GQ, 1GS, G21;	<b>F8-6041</b>		H=53
Protective Cap/Bellow, shock absorber	1.6, 1.8, 1.8 T, 1.9 TDI	for OE: 1JM;	<b>F8-6044</b>		H=160
Protective Cap/Bellow, shock absorber	1.6, 1.8, 1.8 T, 1.9 TDI		<b>F8-6045</b>		
Protective Cap/Bellow, shock absorber	1.8 T quattro	AJQ	<b>F8-6045</b>		
Mounting, axle beam	1.6, 1.8, 1.8 T, 1.8 T quattro, 1.9 TDI		<b>F8-6076</b>		d=12; L=90; D=69
Mounting, axle beam	1.8 T quattro	AQA	<b>F8-6076</b>		d=12; L=90; D=69
Repair Set, axle beam	1.6, 1.8, 1.8 T, 1.8 T quattro, 1.9 TDI		<b>F8-6077</b>		H=90; D=69
Top Strut Mounting	All Models		<b>F8-6280</b>		H=53; d=26; D=82
Belt Pulley, crankshaft	1.9 TDI	01/2001 →; Number of Ribs: 5; Parameter: 6PK	<b>F8-6392</b>		H=47; d=30; D=143
Belt Pulley, crankshaft	1.9 TDI, 1.9 TDI quattro	Number of Ribs: 5; Parameter: 6PK	<b>F8-6392</b>		H=47; d=30; D=143
Belt Pulley, crankshaft	1.9 TDI	ch.8L-3-070001, 8L-31222001→; Number of Ribs: 5; Parameter: 6PK	<b>F8-6396</b>		H=41.6; d=30; Mounting points diam.[mm]=7, 8.6; D=139.7
Belt Pulley, crankshaft	1.9 TDI	ch.8L-3-070001, 8L-31222001→;  ALH; Number of Ribs: 5; Parameter: 6PK	<b>F8-6396</b>		H=41.6; d=30; Mounting points diam.[mm]=7, 8.6; D=139.7
Control Arm-/Trailing Arm Bush	1.6, 1.8, 1.8 T, 1.8 T quattro, 1.9 TDI, 1.9 TDI quattro	Aluminium	<b>F8-6424</b>		
Control Arm-/Trailing Arm Bush	1.6, 1.8, 1.8 T, 1.8 T quattro, 1.9 TDI, 1.9 TDI quattro	Aluminium	<b>F8-6425</b>		
Control Arm-/Trailing Arm Bush	S3 quattro		<b>F8-6464</b>		H=41; d=13.5; W=60
Control Arm-/Trailing Arm Bush	S3 quattro	ch.8L-Y-117501→	<b>F8-6464</b>		H=41; d=13.5; W=60
Bracket, stabilizer mounting	All Models		<b>F8-6579</b>		
Control Arm-/Trailing Arm Bush	S3 quattro		<b>F8-6775</b>		H=54; d=12; D=45
Control Arm-/Trailing Arm Bush	S3 quattro	ch.8L-Y-117501→;  AMK, APY	<b>F8-6775</b>		H=54; d=12; D=45
Engine Mounting	1.9 TDI, 1.9 TDI quattro		<b>F8-6960</b>		
Engine Mounting	S3 quattro		<b>F8-7033</b>		

<b>F8-5996</b>	<b>F8-6007</b>	<b>F8-6012</b>	<b>F8-6013</b>	<b>F8-6041</b>	<b>F8-6044</b>	<b>F8-6045</b>
Ref.Nr.: 1H0412303B	Ref.Nr.: 1J0512131C	Ref.Nr.: 1J0512131	Ref.Nr.: 1J0412131B	Ref.Nr.: 1J0412303	Ref.Nr.: 3C0513425	Ref.Nr.: 1J0513425A
<b>F8-6076</b>	<b>F8-6077</b>	<b>F8-6280</b>	<b>F8-6392</b>	<b>F8-6396</b>	<b>F8-6424</b>	<b>F8-6425</b>
Ref.Nr.: 1J0501541D	Ref.Nr.: 1J0501541DS	Ref.Nr.: 6R0412249	Ref.Nr.: 038105243	Ref.Nr.: 03G105243	Ref.Nr.: 1K0199232G	Ref.Nr.: 1K0199231J
<b>F8-6464</b>	<b>F8-6579</b>	<b>F8-6775</b>	<b>F8-6960</b>	<b>F8-7033</b>		
Ref.Nr.: 8N0407181B	Ref.Nr.: 1J0 411 336 C	Ref.Nr.: 8N0407182A	Ref.Nr.: 1J0199262P	Ref.Nr.: 8N0199555C		

**Article Description**

**Article Nr.**
**Fitting Position**

**A3 (8L1) 09/1996 → 05/2003**

Engine Mounting	S3 quattro	ch.8L-Y-013168→;  AMK, APY	<b>F8-7033</b>		
Mounting, axle bracket	1.8 T quattro, 1.9 TDI quattro, S3 quattro		<b>F8-7046</b>		H=55; d=16; D=52
Mounting, axle bracket	S3 quattro	AMK, APY	<b>F8-7046</b>		H=55; d=16; D=52
Top Strut Mounting	All Models	for OE: 1J0412319C	<b>F8-7133</b>		
Belt Pulley, crankshaft	1.9 TDI	ch.→8L-3070000, 8L-31-222000	<b>F8-7864</b>		
Belt Pulley, crankshaft	1.9 TDI	ch.→8L-3070000, 8L-31-222000;  ALH	<b>F8-7864</b>		
Belt Pulley, crankshaft	1.9 TDI	AGR	<b>F8-7864</b>		
Stabiliser Mounting	1.8 T quattro, 1.9 TDI quattro	ch.8L-X-140001→; for OE: 0AR	<b>F8-7901</b>		
Stabiliser Mounting	S3 quattro	ch.8L-Y-142001→; for OE: 0AN, 0AR	<b>F8-7901</b>		
Stabiliser Mounting	1.6, 1.8, 1.8 T, 1.9 TDI	ch.→8L-W-001701	<b>F8-7927</b>		d=18
Stabiliser Mounting	1.8 T quattro, 1.9 TDI quattro, S3 quattro		<b>F8-7927</b>		d=18
Control Arm-/Trailing Arm Bush	1.6, 1.8, 1.8 T, 1.8 T quattro, 1.9 TDI, 1.9 TDI quattro, S3 quattro		<b>F8-7978</b>		
Control Arm-/Trailing Arm Bush	All Models		<b>G9-648</b>		H=54; d=12; D1=33; D2=36
Control Arm-/Trailing Arm Bush	All Models		<b>G9-649</b>		H1=25; H2=41; d=13; D=60
Bellow, steering	All Models	with clamps;	<b>LM-10020S</b>		d1=16; d2=48; L [mm]=179
Bellow Set, drive shaft	1.8 T	ARZ; with clamps;	<b>MK-810160</b>		L=116
Bellow Set, drive shaft	1.8 T	AUQ; with clamps;	<b>MK-810160</b>		L=116
Bellow Set, drive shaft	1.9 TDI	ATD; with clamps;	<b>MK-810160</b>		L=116

**A3 (8P1) 05/2003 → 08/2012**

Alternator Freewheel Clutch	1.6, 1.6 E-Power, 1.6 TDI, 1.9 TDI, 2.0, 2.0 FSI, 2.0 TDI, 2.0 TDI 16V, 2.0 TDI 16V quattro, 2.0 TDI quattro, 2.0 TFSI, 2.0 TFSI quattro, 3.2 V6 quattro, S3 quattro		<b>F5-1004</b>		
Alternator Freewheel Clutch	1.8 TFSI, 1.8 TFSI quattro, 2.0 TFSI, 2.0 TFSI quattro		<b>F5-1044</b>		
Alternator Freewheel Clutch	1.2 TSI, 1.4 TFSI		<b>F5-1064</b>		
Alternator Freewheel Clutch	3.2 V6 quattro		<b>F5-1085</b>		
Stabiliser Mounting	1.6, 2.0 FSI, 2.0 TDI 16V		<b>F8-5382</b>		D=14
Control Arm-/Trailing Arm Bush	All Models		<b>F8-5633</b>		
Belt Pulley, crankshaft	2.0 FSI		<b>F8-5650</b>		
Protective Cap/Bellow, shock absorber	1.2 TSI, 1.4 TFSI, 1.6, 1.6 E-Power, 1.6 TDI, 1.8 T, 1.8 TFSI, 1.8 TFSI quattro, 1.9 TDI, 2.0, 2.0 FSI, 2.0 TDI, 2.0 TDI 16V, 2.0 TDI 16V quattro, 2.0 TDI quattro, 2.0 TFSI, 2.0 TFSI quattro, 3.2 V6 quattro, S3 quattro	for OE: UA6, UA7;	<b>F8-6044</b>		H=160
Protective Cap/Bellow, shock absorber	1.8 TFSI quattro	for OE: UB5;	<b>F8-6044</b>		H=160

<b>F5-1004</b>	<b>F5-1044</b>	<b>F5-1064</b>	<b>F5-1085</b>	<b>F8-5382</b>	<b>F8-5633</b>	<b>F8-5650</b>
Ref.Nr.: 038903119T	Ref.Nr.: 06B903119B	Ref.Nr.: 03C903119D	Ref.Nr.: 045903119A	Ref.Nr.: 1J0411327	Ref.Nr.: 1K0407182A	Ref.Nr.: 06A105243E
<b>F8-6044</b>	<b>F8-7033</b>	<b>F8-7046</b>	<b>F8-7133</b>	<b>F8-7864</b>	<b>F8-7901</b>	<b>F8-7927</b>
Ref.Nr.: 3C0513425	Ref.Nr.: 8N0199555C	Ref.Nr.: 1J0505145B	Ref.Nr.: 1J0412319C	Ref.Nr.: 038 105 243	Ref.Nr.: 1J0411314P	Ref.Nr.: 1J0411314AC
<b>F8-7978</b>	<b>G9-648</b>	<b>G9-649</b>	<b>LM-10020S</b>	<b>MK-810160</b>		
Ref.Nr.: 357407182F	Ref.Nr.: 357407182	Ref.Nr.: 1J0407181	Ref.Nr.: 1J0422831B	Ref.Nr.: 3D0 498 201		



**Article Description****Article Nr.****Fitting Position**

<b>A3 (8P1)</b>				<b>05/2003 → 08/2012</b>	
Protective Cap/Bellow, shock absorber	2.0 TDI 16V quattro, 2.0 TDI quattro, 2.0 TFSI quattro, 3.2 V6 quattro, S3 quattro	ch.8P-6A112110, 8P-6B013067→; for OE: UB5;	<b>F8-6044</b>		H=160
Top Strut Mounting	All Models		<b>F8-6284</b>		
Top Strut Mounting	1.4 TFSI, 1.6, 1.6 FSI, 1.8 T, 1.8 TFSI, 1.8 TFSI quattro, 1.9 TDI, 2.0, 2.0 FSI, 2.0 TDI, 2.0 TDI 16V, 2.0 TDI 16V quattro, 2.0 TDI quattro, 2.0 TFSI, 2.0 TFSI quattro, 3.2 V6 quattro	for OE: 1K0513353H; Shape Oval	<b>F8-6349</b>		
Belt Pulley, crankshaft	1.9 TDI, 2.0 TDI, 2.0 TDI 16V, 2.0 TDI 16V quattro, 2.0 TDI quattro	Number of Ribs: 5; Parameter: 6PK	<b>F8-6396</b>		H=41.6; d=30; Mounting points diam.[mm]=7, 8.6; D=139.7
Control Arm-/Trailing Arm Bush	1.4 TFSI, 1.6, 1.6 FSI, 1.6 TDI, 1.8 T, 1.8 TFSI, 1.8 TFSI quattro, 1.9 TDI, 2.0, 2.0 FSI, 2.0 TDI, 2.0 TDI 16V, 2.0 TDI 16V quattro, 2.0 TDI quattro, 2.0 TFSI, 2.0 TFSI quattro, 3.2 V6 quattro, S3 quattro	Aluminium	<b>F8-6424</b>		
Control Arm-/Trailing Arm Bush	1.4 TFSI, 1.6, 1.6 FSI, 1.6 TDI, 1.8 T, 1.8 TFSI, 1.8 TFSI quattro, 1.9 TDI, 2.0, 2.0 FSI, 2.0 TDI, 2.0 TDI 16V, 2.0 TDI 16V quattro, 2.0 TDI quattro, 2.0 TFSI, 2.0 TFSI quattro, 3.2 V6 quattro, S3 quattro	Aluminium	<b>F8-6425</b>		
Control Arm-/Trailing Arm Bush	1.4 TFSI, 1.6, 1.6 FSI, 1.6 TDI, 1.8 T, 1.8 TFSI, 1.8 TFSI quattro, 1.9 TDI, 2.0, 2.0 FSI, 2.0 TDI, 2.0 TDI 16V, 2.0 TDI 16V quattro, 2.0 TDI quattro, 2.0 TFSI, 2.0 TFSI quattro, 3.2 V6 quattro, S3 quattro		<b>F8-6463</b>		H=64; d=12; D=60
Engine Mounting	1.9 TDI		<b>F8-6528</b>		
Engine Mounting	2.0 TDI	Transmission Type: Dual-clutch transmission,	<b>F8-6528</b>		
Engine Mounting	2.0 TDI 16V	Transmission Type: Dual-clutch transmission,  6-speed	<b>F8-6528</b>		
Engine Mounting	2.0 TDI, 2.0 TDI 16V quattro, 2.0 TDI quattro		<b>F8-6528</b>		
Engine Mounting	2.0 TDI, 2.0 TDI quattro	BMN	<b>F8-6528</b>		
Engine Mounting	2.0 TFSI, 2.0 TFSI quattro	6-speed	<b>F8-6528</b>		
Engine Mounting	1.6 FSI		<b>F8-6531</b>		H=117.7; L=165; W=149
Anti-Friction Bearing	All Models		<b>F8-6569</b>		
Top Strut Mounting	All Models		<b>F8-6570</b>		
Belt Pulley, crankshaft	1.6 TDI	Number of Ribs: 5; Parameter: 6PK	<b>F8-6572</b>		
Belt Pulley, crankshaft	2.0 TDI	CFFA; Number of Ribs: 5; Parameter: 6PK	<b>F8-6572</b>		
Belt Pulley, crankshaft	2.0 TDI 16V	CFFB, CLJA; Number of Ribs: 5; Parameter: 6PK	<b>F8-6572</b>		
Belt Pulley, crankshaft	2.0 TDI 16V quattro	CFFB; Number of Ribs: 5; Parameter: 6PK	<b>F8-6572</b>		
Belt Pulley, crankshaft	2.0 TDI, 2.0 TDI quattro	CFGB; Number of Ribs: 5; Parameter: 6PK	<b>F8-6572</b>		
Bracket, stabilizer mounting	1.6 FSI	BAG, BLP	<b>F8-6579</b>		

<b>F8-6044</b>	<b>F8-6284</b>	<b>F8-6349</b>	<b>F8-6396</b>	<b>F8-6424</b>	<b>F8-6425</b>	<b>F8-6463</b>
Ref.Nr.: 3C0513425	Ref.Nr.: 6N0412249C	Ref.Nr.: 1K0513353H	Ref.Nr.: 03G105243	Ref.Nr.: 1K0199232G	Ref.Nr.: 1K0199231J	Ref.Nr.: 1K0505541B
<b>F8-6528</b>	<b>F8-6531</b>	<b>F8-6569</b>	<b>F8-6570</b>	<b>F8-6572</b>	<b>F8-6579</b>	
Ref.Nr.: 1K0 199 262 AT	Ref.Nr.: 1K0199262T	Ref.Nr.: 6N0412249C	Ref.Nr.: 1K0412331C	Ref.Nr.: 038105243L	Ref.Nr.: 1J0 411 336 C	

**Article Description**

**Article Nr.**
**Fitting Position**

<b>A3 (8P1)</b>			<b>05/2003 → 08/2012</b>		
Bracket, stabilizer mounting	1.6, 1.8 T, 1.9 TDI, 2.0 TDI, 2.0 TDI 16V, 2.0 TDI 16V quattro, 2.0 TDI quattro, 2.0 TFSI quattro		<b>F8-6579</b>		
Bracket, stabilizer mounting	2.0 FSI	AXW, BLR, BLX, BLY, BMB, BVY, BVZ	<b>F8-6579</b>		
Bracket, stabilizer mounting	2.0 TFSI	AXX	<b>F8-6579</b>		
Bracket, stabilizer mounting	3.2 V6 quattro	BDB, BMJ	<b>F8-6579</b>		
Control Arm-/Trailing Arm Bush	S3 quattro		<b>F8-6775</b>	⊕ ⊕	H=54; d=12; D=45
Engine Mounting	1.6		<b>F8-6988</b>	⊕	
Engine Mounting	1.8 TFSI, 1.8 TFSI quattro, 2.0 FSI, 2.0 TFSI, 2.0 TFSI quattro, S3 quattro		<b>F8-6989</b>	⊕	
Engine Mounting	3.2 V6 quattro	BDB, BMJ	<b>F8-7008</b>	⊕	
Rubber Buffer, suspension	1.6, 1.6 FSI, 1.9 TDI, 2.0 FSI, 2.0 TDI, 2.0 TDI 16V, 2.0 TFSI	ch.→8P-6A110320, 8P-6B011800; for OE: G35;	<b>F8-7131</b>	⊕ ⊕	H=70
Rubber Buffer, suspension	1.6, 1.9 TDI, 2.0 FSI	for OE: G35;	<b>F8-7131</b>	⊕ ⊕ ⊕	H=70
Protective Cap/Bellow, shock absorber	1.2 TSI, 1.4 TFSI, 1.6, 1.6 E-Power, 1.6 FSI, 1.6 TDI, 1.8 T, 1.8 TFSI, 1.8 TFSI quattro, 1.9 TDI, 2.0 FSI, 2.0 TDI, 2.0 TDI 16V, 2.0 TDI 16V quattro, 2.0 TDI quattro, 2.0 TFSI, 2.0 TFSI quattro, 3.2 V6 quattro, S3 quattro		<b>F8-7132</b>	⊕ ⊕ ⊕	H=190
Rubber Buffer, suspension	1.2 TSI, 1.4 TFSI, 1.6, 1.6 E-Power, 1.6 FSI, 1.6 TDI, 1.8 T, 1.8 TFSI, 1.8 TFSI quattro, 1.9 TDI, 2.0, 2.0 FSI, 2.0 TDI, 2.0 TDI 16V, 2.0 TDI 16V quattro, 2.0 TDI quattro, 2.0 TFSI, 2.0 TFSI quattro, 3.2 V6 quattro	for OE: UA0; Shape Oval;	<b>F8-7579</b>	⊕ ⊕	H=100
Rubber Buffer, suspension	1.2 TSI, 1.4 TFSI, 1.6, 1.6 E-Power, 1.6 FSI, 1.6 TDI, 1.8 T, 1.8 TFSI, 1.8 TFSI quattro, 1.9 TDI, 2.0, 2.0 FSI, 2.0 TDI, 2.0 TDI 16V, 2.0 TDI 16V quattro, 2.0 TDI quattro, 2.0 TFSI, 2.0 TFSI quattro, 3.2 V6 quattro	for OE: UA1, UA9; Shape Oval;	<b>F8-7579</b>	⊕ ⊕	H=100
Rubber Buffer, suspension	1.2 TSI, 1.4 TFSI, 1.6, 1.6 E-Power, 1.6 FSI, 1.6 TDI, 1.8 T, 1.8 TFSI, 1.8 TFSI quattro, 1.9 TDI, 2.0, 2.0 FSI, 2.0 TDI, 2.0 TDI 16V, 2.0 TDI 16V quattro, 2.0 TDI quattro, 2.0 TFSI, 2.0 TFSI quattro, 3.2 V6 quattro	for OE: UA2; Shape Oval;	<b>F8-7579</b>	⊕ ⊕	H=100
Rubber Buffer, suspension	1.2 TSI, 1.4 TFSI, 1.6, 1.6 E-Power, 1.6 FSI, 1.6 TDI, 1.8 T, 1.8 TFSI, 1.8 TFSI quattro, 1.9 TDI, 2.0, 2.0 FSI, 2.0 TDI, 2.0 TDI 16V, 2.0 TDI 16V quattro, 2.0 TDI quattro, 2.0 TFSI, 2.0 TFSI quattro, 3.2 V6 quattro	S line; for OE: UA3; Shape Oval	<b>F8-7579</b>	⊕ ⊕	H=100
Top Strut Mounting	1.2 TSI, 1.4 TFSI, 1.6, 1.6 E-Power, 1.6 FSI, 1.6 TDI, 1.8 T, 1.8 TFSI, 1.8 TFSI quattro, 1.9 TDI, 2.0, 2.0 FSI, 2.0 TDI, 2.0 TDI 16V, 2.0 TDI 16V quattro, 2.0 TDI quattro, 2.0 TFSI, 2.0 TFSI quattro, 3.2 V6 quattro, S3 quattro	for OE: 1K0513353R, 3C0513353C; Shape Round	<b>F8-7603</b>	⊕ ⊕	
Protective Cap/Bellow, shock absorber	1.2 TSI, 1.4 TFSI, 1.6, 1.6 E-Power, 1.6 TDI, 1.8 T, 1.8 TFSI, 1.8 TFSI quattro, 1.9 TDI, 2.0, 2.0 TDI, 2.0 TDI 16V, 2.0 TDI 16V quattro, 2.0 TDI quattro, 2.0 TFSI, 2.0 TFSI quattro, 3.2 V6 quattro	for OE: UA0; Shape Round;	<b>F8-7627</b>	⊕ ⊕	H=178

<b>F8-6579</b>	<b>F8-6775</b>	<b>F8-6988</b>	<b>F8-6989</b>	<b>F8-7008</b>	<b>F8-7131</b>	<b>F8-7132</b>
Ref.Nr.: 1J0 411 336 C	Ref.Nr.: 8N0407182A	Ref.Nr.: 1K0199262AL	Ref.Nr.: 1K0199262AM	Ref.Nr.: 1K0199262Q	Ref.Nr.: 1K0412303B	Ref.Nr.: 6N0413175A
<b>F8-7579</b>	<b>F8-7603</b>	<b>F8-7627</b>				
Ref.Nr.: 1K0 511 353 J	Ref.Nr.: 3C0513353	Ref.Nr.: 1K0513425D				

**Article Description****Article Nr.****Fitting Position**

<b>A3 (8P1)</b>		<b>05/2003 → 08/2012</b>			
Protective Cap/Bellow, shock absorber	1.2 TSI, 1.4 TFSI, 1.6, 1.6 E-Power, 1.6 TDI, 1.8 T, 1.8 TFSI, 1.8 TFSI quattro, 1.9 TDI, 2.0, 2.0 TDI, 2.0 TDI 16V, 2.0 TDI 16V quattro, 2.0 TDI quattro, 2.0 TFSI, 2.0 TFSI quattro, 3.2 V6 quattro	for OE: UA2; Shape Round;	<b>F8-7627</b>		H=178
Protective Cap/Bellow, shock absorber	1.2 TSI, 1.4 TFSI, 1.6, 1.6 E-Power, 1.6 TDI, 1.8 T, 1.8 TFSI, 1.8 TFSI quattro, 1.9 TDI, 2.0, 2.0 TDI, 2.0 TDI 16V, 2.0 TDI 16V quattro, 2.0 TDI quattro, 2.0 TFSI, 2.0 TFSI quattro, 3.2 V6 quattro	S line; for OE: UA3; Shape Round	<b>F8-7627</b>		H=178
Protective Cap/Bellow, shock absorber	1.2 TSI, 1.4 TFSI, 1.6, 1.6 E-Power, 1.6 TDI, 1.8 T, 1.8 TFSI, 1.9 TDI, 2.0, 2.0 TDI, 2.0 TDI 16V, 2.0 TFSI	for OE: UA1; Shape Round;	<b>F8-7627</b>		H=178
Protective Cap/Bellow, shock absorber	1.6 FSI, 2.0 FSI, 2.0 TDI	Shape Round	<b>F8-7627</b>		H=178
Protective Cap/Bellow, shock absorber	1.8 TFSI quattro, 2.0 TDI 16V quattro, 2.0 TDI quattro, 2.0 TFSI quattro, 3.2 V6 quattro	for OE: UA1, UA9; Shape Round;	<b>F8-7627</b>		H=178
Rubber Buffer, suspension	1.2 TSI, 1.4 TFSI, 1.6, 1.6 E-Power, 1.6 FSI, 1.6 TDI, 1.8 T, 1.8 TFSI, 1.8 TFSI quattro, 1.9 TDI, 2.0 FSI, 2.0 TDI, 2.0 TDI 16V, 2.0 TDI 16V quattro, 2.0 TDI quattro, 2.0 TFSI, 2.0 TFSI quattro, 3.2 V6 quattro, S3 quattro	for OE: G12;	<b>F8-7697</b>		H=55
Rubber Buffer, suspension	1.2 TSI, 1.4 TFSI, 1.6, 1.6 FSI, 1.6 TDI, 1.8 T, 1.8 TFSI, 1.8 TFSI quattro, 1.9 TDI, 2.0 FSI, 2.0 TDI, 2.0 TDI 16V, 2.0 TDI 16V quattro, 2.0 TDI quattro, 2.0 TFSI, 2.0 TFSI quattro, 3.2 V6 quattro, S3 quattro	ch.→8P-6A110320, 8P-6B011800; for OE: G38;	<b>F8-7697</b>		H=55
Rubber Buffer, suspension	1.2 TSI, 1.4 TFSI, 1.6, 1.6 FSI, 1.6 TDI, 1.8 T, 1.8 TFSI, 1.8 TFSI quattro, 1.9 TDI, 2.0 FSI, 2.0 TDI, 2.0 TDI 16V, 2.0 TDI 16V quattro, 2.0 TDI quattro, 2.0 TFSI, 2.0 TFSI quattro, 3.2 V6 quattro, S3 quattro	ch.8P-6B011800→; ch.→8P-6A110320; for OE: G32;	<b>F8-7697</b>		H=55
Rubber Buffer, suspension	1.2 TSI, 1.4 TFSI, 1.6, 1.6 TDI, 1.8 T, 1.8 TFSI, 2.0, 2.0 TDI, 2.0 TDI 16V, 2.0 TFSI	ch.8P-BA000001→; for OE: G17, G43; 2011→;	<b>F8-7831</b>		H=90
Rubber Buffer, suspension	1.6, 1.6 FSI, 1.8 T, 1.8 TFSI, 1.9 TDI, 2.0, 2.0 FSI, 2.0 TDI, 2.0 TDI 16V, 2.0 TFSI	ch.8P-4-130001→; for OE: G43; →2007;	<b>F8-7831</b>		H=90
Rubber Buffer, suspension	1.2 TSI, 1.4 TFSI, 1.6 TDI	for OE: G32, G38;	<b>F8-7832</b>		H=85
Rubber Buffer, suspension	1.2 TSI, 1.4 TFSI, 1.6, 1.6 TDI, 1.8 T, 1.8 TFSI, 1.9 TDI, 2.0, 2.0 TDI, 2.0 TDI 16V, 2.0 TFSI	ch.→8P-9B050000; for OE: G31; →2010;	<b>F8-7832</b>		H=85
Rubber Buffer, suspension	1.2 TSI, 1.4 TFSI, 1.6, 1.6 TDI, 1.8 T, 1.8 TFSI, 1.9 TDI, 2.0, 2.0 TDI, 2.0 TDI 16V, 2.0 TFSI	ch.→8P-9B050000; for OE: G37; →2010;	<b>F8-7832</b>		H=85
Rubber Buffer, suspension	1.6 FSI, 2.0 FSI, 2.0 TDI	for OE: G31;	<b>F8-7832</b>		H=85
Rubber Buffer, suspension	1.6 FSI, 2.0 FSI, 2.0 TDI	for OE: G37;	<b>F8-7832</b>		H=85
Rubber Buffer, suspension	1.6, 1.6 FSI, 1.8 T, 1.8 TFSI, 1.9 TDI, 2.0, 2.0 FSI, 2.0 TDI, 2.0 TDI 16V, 2.0 TFSI	ch.→8P-4-130000; for OE: G43;	<b>F8-7832</b>		H=85
Rubber Buffer, suspension	1.6, 1.6 FSI, 1.8 T, 1.8 TFSI, 1.9 TDI, 2.0, 2.0 FSI, 2.0 TDI, 2.0 TDI 16V, 2.0 TFSI	ch.8P-4-020901→; for OE: G32, G38;	<b>F8-7832</b>		H=85
Rubber Buffer, suspension	1.8 TFSI quattro, 2.0 TDI 16V quattro, 2.0 TDI quattro, 2.0 TFSI quattro	ch.→8P-9B050000; for OE: G44; →2010;	<b>F8-7832</b>		H=85
Rubber Buffer, suspension	1.8 TFSI quattro, 2.0 TDI 16V quattro, 2.0 TDI quattro, 2.0 TFSI quattro, 3.2 V6 quattro, S3 quattro	ch.→8P-9B050000; for OE: G33;	<b>F8-7832</b>		H=85



**Article Description**

**Article Nr.**
**Fitting Position**

<b>A3 (8P1)</b>			<b>05/2003 → 08/2012</b>		
Rubber Buffer, suspension	1.8 TFSI quattro, 2.0 TDI 16V quattro, 2.0 TDI quattro, 2.0 TFSI quattro, 3.2 V6 quattro, S3 quattro	ch.8P-7-081500→; ch.→8P-9B050000; for OE: G36; <b>SP</b>	<b>F8-7832</b>		H=85
Rubber Buffer, suspension	2.0 TDI quattro	ch.8P-7-081500→; <b>SP</b>	<b>F8-7832</b>		H=85
Rubber Buffer, suspension	2.0 TDI quattro, 3.2 V6 quattro	for OE: G44; <b>ST</b>	<b>F8-7832</b>		H=85
Rubber Buffer, suspension	1.2 TSI, 1.4 TFSI, 1.6 TDI, 1.8 T, 1.8 TFSI, 2.0, 2.0 TDI	for OE: G35; <b>ST</b>	<b>F8-7833</b>		H=86
Rubber Buffer, suspension	1.2 TSI, 1.4 TFSI, 1.6, 1.6 FSI, 1.6 TDI, 1.8 T, 1.8 TFSI, 1.9 TDI, 2.0, 2.0 FSI, 2.0 TDI, 2.0 TDI 16V, 2.0 TFSI	for OE: G20; <b>SP</b>	<b>F8-7833</b>		H=86
Rubber Buffer, suspension	1.4 TFSI, 1.6, 1.6 FSI, 1.6 TDI, 1.8 T, 1.8 TFSI, 1.9 TDI, 2.0, 2.0 FSI, 2.0 TDI, 2.0 TDI 16V, 2.0 TFSI	ch.8P-8A000001→; ch.→8P-9B050000; for OE: G43; 2008→; →2010; <b>ST</b>	<b>F8-7833</b>		H=86
Rubber Buffer, suspension	1.4 TFSI, 1.6, 1.6 TDI, 1.8 T, 1.8 TFSI, 1.9 TDI, 2.0, 2.0 TDI, 2.0 TDI 16V, 2.0 TFSI	ch.→8P-9B050000; for OE: G17; →2010; <b>ST</b>	<b>F8-7833</b>		H=86
Rubber Buffer, suspension	1.6 FSI, 2.0 FSI, 2.0 TDI	for OE: G17; <b>ST</b>	<b>F8-7833</b>		H=86
Rubber Buffer, suspension	1.6, 1.6 FSI, 1.9 TDI, 2.0 FSI, 2.0 TDI, 2.0 TDI 16V, 2.0 TFSI	ch.8P-6A110321, 8P-6B011801→; for OE: G35; <b>ST</b>	<b>F8-7833</b>		H=86
Rubber Buffer, suspension	1.2 TSI, 1.4 TFSI, 1.6, 1.6 E-Power, 1.6 FSI, 1.6 TDI, 1.8 T, 1.8 TFSI, 1.8 TFSI quattro, 1.9 TDI, 2.0, 2.0 FSI, 2.0 TDI, 2.0 TDI 16V, 2.0 TDI 16V quattro, 2.0 TDI quattro, 2.0 TFSI, 2.0 TFSI quattro, 3.2 V6 quattro	for OE: UA0; Shape Round; <b>ST</b>	<b>F8-7835</b>		H=75
Rubber Buffer, suspension	1.2 TSI, 1.4 TFSI, 1.6, 1.6 E-Power, 1.6 FSI, 1.6 TDI, 1.8 T, 1.8 TFSI, 1.8 TFSI quattro, 1.9 TDI, 2.0, 2.0 FSI, 2.0 TDI, 2.0 TDI 16V, 2.0 TDI 16V quattro, 2.0 TDI quattro, 2.0 TFSI, 2.0 TFSI quattro, 3.2 V6 quattro	for OE: UA1, UA9; Shape Round; <b>SP</b>	<b>F8-7835</b>		H=75
Rubber Buffer, suspension	1.2 TSI, 1.4 TFSI, 1.6, 1.6 E-Power, 1.6 FSI, 1.6 TDI, 1.8 T, 1.8 TFSI, 1.8 TFSI quattro, 1.9 TDI, 2.0, 2.0 FSI, 2.0 TDI, 2.0 TDI 16V, 2.0 TDI 16V quattro, 2.0 TDI quattro, 2.0 TFSI, 2.0 TFSI quattro, 3.2 V6 quattro	for OE: UA2; Shape Round; <b>Δ</b>	<b>F8-7835</b>		H=75
Rubber Buffer, suspension	1.2 TSI, 1.4 TFSI, 1.6, 1.6 E-Power, 1.6 FSI, 1.6 TDI, 1.8 T, 1.8 TFSI, 1.8 TFSI quattro, 1.9 TDI, 2.0, 2.0 FSI, 2.0 TDI, 2.0 TDI 16V, 2.0 TDI 16V quattro, 2.0 TDI quattro, 2.0 TFSI, 2.0 TFSI quattro, 3.2 V6 quattro	S line; for OE: UA3; Shape Round	<b>F8-7835</b>		H=75
Belt Pulley, crankshaft	1.8 TFSI, 1.8 TFSI quattro, 2.0 TFSI, 2.0 TFSI quattro	Number of Ribs: 5; Parameter: 6PK	<b>F8-7880</b>		D=143
Rubber Buffer, suspension	S3 quattro	for OE: UB5	<b>F8-7894</b>		
Control Arm-/Trailing Arm Bush	All Models		<b>F8-7902</b>		H=60; d=12; D=42
Control Arm-/Trailing Arm Bush	All Models		<b>F8-7907</b>		H=45; d=14; D=38
Control Arm-/Trailing Arm Bush	All Models		<b>F8-7908</b>		H=45; d=12; D=38
Control Arm-/Trailing Arm Bush	All Models		<b>F8-7909</b>		
Stabiliser Mounting	1.6, 1.6 FSI, 1.8 T, 1.8 TFSI, 1.9 TDI, 2.0, 2.0 FSI, 2.0 TDI, 2.0 TDI 16V, 2.0 TDI 16V quattro, 2.0 TDI quattro, 2.0 TFSI, 2.0 TFSI quattro, 3.2 V6 quattro, S3 quattro		<b>F8-7923</b>		d=20,7

<b>F8-7832</b>	<b>F8-7833</b>	<b>F8-7835</b>	<b>F8-7880</b>	<b>F8-7894</b>	<b>F8-7902</b>	<b>F8-7907</b>
Ref.Nr.: 1K0412303P	Ref.Nr.: 1K0412303T	Ref.Nr.: 1K0511353S	Ref.Nr.: 06H105243F	Ref.Nr.: 8J0511353F	Ref.Nr.: 1K0505171C	Ref.Nr.: 1K0505203A
<b>F8-7908</b>	<b>F8-7909</b>	<b>F8-7923</b>	<b>F8-7930</b>			
Ref.Nr.: 1K0505279A	Ref.Nr.: 1K0505553 A	Ref.Nr.: 1K0511327AR	Ref.Nr.: 1K0511327AP			

**Article Description****Article Nr.****Fitting Position**

<b>A3 (8P1)</b>			<b>05/2003 → 08/2012</b>		
Stabiliser Mounting	1.6, 1.6 FSI, 1.9 TDI, 2.0 FSI, 2.0 TDI, 2.0 TDI 16V, 2.0 TDI 16V quattro, 2.0 TDI quattro, 2.0 TFSI, 2.0 TFSI quattro, 3.2 V6 quattro		<b>F8-7930</b>		d=18,5
Engine Mounting	1.9 TDI		<b>F8-7958</b>		
Engine Mounting	1.4 TFSI	CAXC	<b>F8-7959</b>		
Engine Mounting	1.4 TFSI, 1.6		<b>F8-7960</b>		
Engine Mounting	1.6 FSI		<b>F8-7960</b>		
Engine Mounting	1.6, 2.0 FSI		<b>F8-7961</b>		
Engine Mounting	1.8 TFSI, 1.8 TFSI quattro	CDAA	<b>F8-7961</b>		
Engine Mounting	1.9 TDI, 2.0 TDI, 2.0 TDI 16V, 2.0 TDI 16V quattro, 2.0 TDI quattro		<b>F8-7962</b>		
Engine Mounting	2.0 TFSI, 2.0 TFSI quattro	6-speed	<b>F8-7962</b>		
Engine Mounting	1.2 TSI		<b>F8-7965</b>		
Engine Mounting	1.4 TFSI	CAXC;	<b>F8-7965</b>		
Engine Mounting	1.6	BGU, BSE, BSF, CCSA;	<b>F8-7965</b>		
Engine Mounting	1.6 FSI		<b>F8-7965</b>		
Engine Mounting	1.6	BGU, BSF;	<b>F8-7966</b>		
Engine Mounting	1.6	BSE;	<b>F8-7966</b>		
Engine Mounting	1.8 TFSI	BYT, BZB;  6-speed	<b>F8-7966</b>		
Engine Mounting	1.8 TFSI, 1.8 TFSI quattro	CDAA;  6-speed	<b>F8-7966</b>		
Engine Mounting	1.9 TDI, 2.0 FSI, 2.0 TDI, 2.0 TDI 16V, 2.0 TDI 16V quattro, 2.0 TDI quattro		<b>F8-7966</b>		
Engine Mounting	2.0 TFSI	AXX, BWA, CAWB	<b>F8-7966</b>		
Engine Mounting	2.0 TFSI	CCZA;  6-speed	<b>F8-7966</b>		
Engine Mounting	2.0 TFSI quattro	AXX, BWA	<b>F8-7966</b>		
Engine Mounting	2.0 TFSI, 2.0 TFSI quattro	BWA;  6-speed,  6-speed	<b>F8-7966</b>		
Engine Mounting	2.0 TFSI, 2.0 TFSI quattro	CCZA;  6-speed	<b>F8-7966</b>		
Engine Mounting	S3 quattro	BGU, BSF;  6-speed	<b>F8-7966</b>		
Engine Mounting	1.4 TFSI, 1.6, 2.0 TDI quattro, 2.0 TFSI quattro, 3.2 V6 quattro		<b>F8-7981</b>		
Engine Mounting	1.8 TFSI	BYT, BZB	<b>F8-7981</b>		
Engine Mounting	1.9 TDI	ch.→8P-8A-088000, 8P-8B-010500;  BKC, BXE	<b>F8-7981</b>		
Engine Mounting	2.0 FSI		<b>F8-7981</b>		
Engine Mounting	2.0 TDI	ch.→8P-6A-040000, 8P-6B-004250	<b>F8-7981</b>		
Engine Mounting	2.0 TDI, 2.0 TDI 16V, 2.0 TDI 16V quattro, 2.0 TDI quattro	ch.→8P-8A-088000, 8P-8B-010500	<b>F8-7981</b>		
Engine Mounting	2.0 TFSI	AXX, BWA, CAWB	<b>F8-7981</b>		

<b>F8-7930</b>	<b>F8-7958</b>	<b>F8-7959</b>	<b>F8-7960</b>	<b>F8-7961</b>	<b>F8-7962</b>	<b>F8-7965</b>
Ref.Nr.: 1K0511327AP	Ref.Nr.: 1K0199262AS	Ref.Nr.: 1K0199262CG	Ref.Nr.: 1K0199555L	Ref.Nr.: 1K0199555N	Ref.Nr.: 1K0199555Q	Ref.Nr.: 1K0199855BA
<b>F8-7966</b>	<b>F8-7981</b>	<b>F8-7982</b>				
Ref.Nr.: 1K0199855BB	Ref.Nr.: 1K0199867Q	Ref.Nr.: 1K0199868Q				

Article Description



Article Nr.

Fitting Position



<b>A3 (8P1)</b>			<b>05/2003 → 08/2012</b>		
Engine Mounting	1.2 TFSI, 1.4 TFSI, 1.6 FSI, 1.6 TDI, 1.8 TFSI, 1.8 TFSI quattro, 2.0 TDI, 2.0 TDI quattro, 2.0 TFSI, S3 quattro		<b>F8-7982</b>	↑	
Engine Mounting	1.6	BGU, BSE, BSF, CCSA	<b>F8-7982</b>	↑	
Engine Mounting	1.9 TDI	ch.8P-8A-088001, 8P-8B-010501→	<b>F8-7982</b>	↑	
Engine Mounting	2.0 FSI	AXW, BLR, BLX, BLY, BVY, BVZ	<b>F8-7982</b>	↑	
Engine Mounting	2.0 TDI 16V	BKD, CBAB, CFFB	<b>F8-7982</b>	↑	
Engine Mounting	2.0 TDI 16V quattro, 2.0 TDI quattro	for OE: TL4	<b>F8-7982</b>	↑	
Engine Mounting	2.0 TDI quattro	ch.→8P-6A-040000	<b>F8-7982</b>	↑	
Engine Mounting	2.0 TFSI quattro	AXX, BWA, CCZA	<b>F8-7982</b>	↑	
Engine Mounting	3.2 V6 quattro	ch.→8P-9A-000000	<b>F8-7982</b>	↑	
Engine Mounting	2.0 TDI 16V quattro, 2.0 TDI quattro		<b>F8-8152</b>	↔	
Engine Mounting	2.0, 2.0 TDI, 2.0 TDI 16V, 2.0 TDI quattro		<b>F8-8152</b>	↔	
<b>A3 Convertible (8P7)</b>			<b>04/2008 → 05/2013</b>		
Dust Cover Kit, shock absorber	All Models		<b>AK-735095</b>	↔	
Dust Cover Kit, shock absorber	1.2 TFSI, 1.6, 1.6 TDI, 1.8 TFSI, 1.9 TDI, 2.0 TDI, 2.0 TFSI	for OE: UA0, UA4;	<b>AK-735172</b>	↔	
Alternator Freewheel Clutch	1.6, 1.6 TDI, 1.9 TDI, 2.0 TDI		<b>F5-1004</b>		
Alternator Freewheel Clutch	1.8 TFSI, 2.0 TFSI		<b>F5-1044</b>		
Alternator Freewheel Clutch	1.2 TFSI, 1.4 TFSI		<b>F5-1064</b>		
Control Arm-/Trailing Arm Bush	All Models		<b>F8-5633</b>	↔	
Top Strut Mounting	All Models		<b>F8-6348</b>		
Belt Pulley, crankshaft	1.9 TDI, 2.0 TDI	Number of Ribs: 5; Parameter: 6PK	<b>F8-6396</b>		H=41.6; d=30; Mounting points diam.[mm]=7, 8.6; D=139.7
Control Arm-/Trailing Arm Bush	1.6, 1.6 TDI, 1.8 TFSI, 1.9 TDI, 2.0 TDI, 2.0 TFSI	Aluminium	<b>F8-6424</b>	↔	
Control Arm-/Trailing Arm Bush	1.6, 1.6 TDI, 1.8 TFSI, 1.9 TDI, 2.0 TDI, 2.0 TFSI	Aluminium	<b>F8-6425</b>	↔	
Control Arm-/Trailing Arm Bush	1.6, 1.6 TDI, 1.8 TFSI, 1.9 TDI, 2.0 TDI, 2.0 TFSI		<b>F8-6463</b>	↔	H=64; d=12; D=60
Anti-Friction Bearing	All Models		<b>F8-6569</b>		
Top Strut Mounting	All Models		<b>F8-6570</b>		
Belt Pulley, crankshaft	1.6 TDI	Number of Ribs: 5; Parameter: 6PK	<b>F8-6572</b>		
Belt Pulley, crankshaft	2.0 TDI	CFFA; Number of Ribs: 5; Parameter: 6PK	<b>F8-6572</b>		
Belt Pulley, crankshaft	2.0 TDI	CFFB; Number of Ribs: 5; Parameter: 6PK	<b>F8-6572</b>		
Engine Mounting	1.8 TFSI		<b>F8-6989</b>	↔	
Engine Mounting	2.0 TFSI	CCZA	<b>F8-6989</b>	↔	

<b>AK-735095</b>	<b>AK-735172</b>	<b>F5-1004</b>	<b>F5-1044</b>	<b>F5-1064</b>	<b>F8-5633</b>	<b>F8-6348</b>
Ref.Nr.: 1J0512131B	Ref.Nr.: 1K0511353M	Ref.Nr.: 038903119T	Ref.Nr.: 06B903119B	Ref.Nr.: 03C903119D	Ref.Nr.: 1K0407182A	Ref.Nr.: 1K0513353G
<b>F8-6396</b>	<b>F8-6424</b>	<b>F8-6425</b>	<b>F8-6463</b>	<b>F8-6569</b>	<b>F8-6570</b>	<b>F8-6572</b>
Ref.Nr.: 03G105243	Ref.Nr.: 1K0199232G	Ref.Nr.: 1K0199231J	Ref.Nr.: 1K0505541B	Ref.Nr.: 6N0412249C	Ref.Nr.: 1K0412331C	Ref.Nr.: 038105243L
<b>F8-6989</b>	<b>F8-7132</b>	<b>F8-7982</b>	<b>F8-8152</b>			
Ref.Nr.: 1K0199262AM	Ref.Nr.: 6N0413175A	Ref.Nr.: 1K0199868Q	Ref.Nr.: 1K0199555T			

**Article Description****Article Nr.****Fitting Position****A3 Convertible (8P7)****04/2008 → 05/2013**

Protective Cap/Bellow, shock absorber	All Models		<b>F8-7132</b>		H=190
Rubber Buffer, suspension	1.2 TFSI, 1.6, 1.6 TDI, 1.8 TFSI, 1.9 TDI, 2.0 TDI, 2.0 TFSI	for OE: UA0, UA4; <b>SP</b>	<b>F8-7576</b>		H=133
Rubber Buffer, suspension	All Models	for OE: UA1, UA5; Shape Round; <b>ST</b>	<b>F8-7601</b>		H=118
Protective Cap/Bellow, shock absorber	All Models		<b>F8-7640</b>		H=176
Rubber Buffer, suspension	1.2 TFSI, 1.4 TFSI, 1.6, 1.6 TDI, 1.8 TFSI, 1.9 TDI, 2.0 TDI, 2.0 TFSI	for OE: G26; <b>ST</b>	<b>F8-7832</b>		H=85
Rubber Buffer, suspension	1.2 TFSI, 1.4 TFSI, 1.6, 1.6 TDI, 1.8 TFSI, 1.9 TDI, 2.0 TDI, 2.0 TFSI	for OE: G27; <b>SP</b>	<b>F8-7832</b>		H=85
Belt Pulley, crankshaft	1.8 TFSI, 2.0 TFSI	Number of Ribs: 5; Parameter: 6PK	<b>F8-7880</b>		D=143
Control Arm-/Trailing Arm Bush	All Models		<b>F8-7902</b>		H=60; d=12; D=42
Control Arm-/Trailing Arm Bush	All Models		<b>F8-7907</b>		H=45; d=14; D=38
Control Arm-/Trailing Arm Bush	All Models		<b>F8-7908</b>		H=45; d=12; D=38
Control Arm-/Trailing Arm Bush	All Models		<b>F8-7909</b>		
Engine Mounting	1.4 TFSI		<b>F8-7959</b>		
Engine Mounting	1.4 TFSI, 1.6		<b>F8-7960</b>		
Engine Mounting	1.9 TDI	ch.8P-9-000001 →	<b>F8-7961</b>		
Engine Mounting	1.9 TDI	BLS, BXE;  6-speed	<b>F8-7962</b>		
Engine Mounting	2.0 TDI		<b>F8-7962</b>		
Engine Mounting	2.0 TFSI	6-speed	<b>F8-7962</b>		
Engine Mounting	1.2 TFSI		<b>F8-7965</b>		
Engine Mounting	1.8 TFSI	BZB	<b>F8-7966</b>		
Engine Mounting	1.8 TFSI	CDAA	<b>F8-7966</b>		
Engine Mounting	1.9 TDI, 2.0 TDI		<b>F8-7966</b>		
Engine Mounting	2.0 TFSI	CAWB;  6-speed	<b>F8-7966</b>		
Engine Mounting	2.0 TFSI	CCZA	<b>F8-7966</b>		
Engine Mounting	1.8 TFSI	BZB	<b>F8-7981</b>		
Engine Mounting	2.0 TFSI	CAWB	<b>F8-7981</b>		
Engine Mounting	1.2 TFSI, 1.4 TFSI, 1.6, 1.6 TDI, 2.0 TDI		<b>F8-7982</b>		
Engine Mounting	1.8 TFSI, 2.0 TFSI		<b>F8-7982</b>		
Control Arm-/Trailing Arm Bush	1.4 TFSI, 1.6		<b>F8-7991</b>		

<b>AK-735180</b>	<b>F8-7132</b>	<b>F8-7576</b>	<b>F8-7601</b>	<b>F8-7640</b>	<b>F8-7832</b>	<b>F8-7880</b>
Ref.Nr.: 1K0412303P	Ref.Nr.: 6N0413175A	Ref.Nr.: 1K0 511 353 M	Ref.Nr.: 1K0511353N	Ref.Nr.: 1K0513425A	Ref.Nr.: 1K0412303P	Ref.Nr.: 06H105243F
<b>F8-7902</b>	<b>F8-7907</b>	<b>F8-7908</b>	<b>F8-7909</b>	<b>F8-7959</b>	<b>F8-7960</b>	<b>F8-7961</b>
Ref.Nr.: 1K0505171C	Ref.Nr.: 1K0505203A	Ref.Nr.: 1K0505279A	Ref.Nr.: 1K0505553 A	Ref.Nr.: 1K0199262CG	Ref.Nr.: 1K0199555L	Ref.Nr.: 1K0199555N
<b>F8-7962</b>	<b>F8-7965</b>	<b>F8-7966</b>	<b>F8-7981</b>	<b>F8-7982</b>	<b>F8-7991</b>	
Ref.Nr.: 1K0199555Q	Ref.Nr.: 1K0199855BA	Ref.Nr.: 1K0199855BB	Ref.Nr.: 1K0199867Q	Ref.Nr.: 1K0199868Q	Ref.Nr.: 1K0407183G	

Article Description



Article Nr.

Fitting Position



### A3 Sportback (8PA)

09/2004 → 03/2013

Dust Cover Kit, shock absorber	1.6, 1.6 FSI, 1.8 TFSI, 1.9 TDI, 2.0, 2.0 FSI, 2.0 TDI, 2.0 TDI 16V, 2.0 TDI 16V quattro, 2.0 TDI quattro, 2.0 TFSI, 2.0 TFSI quattro, 3.2 V6 quattro		<b>AK-735180</b>		
Dust Cover Kit, shock absorber	1.6, 1.6 FSI, 1.8 TFSI, 1.9 TDI, 2.0, 2.0 FSI, 2.0 TDI, 2.0 TDI 16V, 2.0 TDI 16V quattro, 2.0 TDI quattro, 2.0 TFSI, 2.0 TFSI quattro, 3.2 V6 quattro		<b>AK-735181</b>		
Alternator Freewheel Clutch	1.6, 1.6 E-Power, 1.6 TDI, 1.9 TDI, 2.0, 2.0 FSI, 2.0 TDI, 2.0 TDI 16V, 2.0 TDI 16V quattro, 2.0 TDI quattro, 2.0 TFSI, 2.0 TFSI quattro, 3.2 V6 quattro, S3 quattro		<b>F5-1004</b>		
Alternator Freewheel Clutch	1.8 TFSI, 1.8 TFSI quattro, 2.0 TFSI, 2.0 TFSI quattro		<b>F5-1044</b>		
Alternator Freewheel Clutch	1.2 TSI, 1.4 TFSI		<b>F5-1064</b>		
Alternator Freewheel Clutch	3.2 V6 quattro		<b>F5-1085</b>		
Control Arm-/Trailing Arm Bush	All Models		<b>F8-5633</b>		
Belt Pulley, crankshaft	2.0 FSI		<b>F8-5650</b>		
Protective Cap/Bellow, shock absorber	1.2 TSI, 1.4 TFSI, 1.6, 1.6 E-Power, 1.6 FSI, 1.6 TDI, 1.8 TFSI, 1.8 TFSI quattro, 1.9 TDI, 2.0, 2.0 FSI, 2.0 TDI, 2.0 TDI 16V, 2.0 TDI 16V quattro, 2.0 TDI quattro, 2.0 TFSI, 2.0 TFSI quattro, 3.2 V6 quattro, S3 quattro	for OE: UA6, UA7;	<b>F8-6044</b>		H=160
Protective Cap/Bellow, shock absorber	1.8 TFSI quattro, S3 quattro	for OE: UB5;	<b>F8-6044</b>		H=160
Protective Cap/Bellow, shock absorber	2.0 TDI 16V quattro, 2.0 TDI quattro, 2.0 TFSI quattro	ch.8P-6A112110, 8P-6B013067→; for OE: UB5;	<b>F8-6044</b>		H=160
Protective Cap/Bellow, shock absorber	3.2 V6 quattro	ch.8P-6A112110, 8P-6B013067→; for OE: UA6, UA7, UB5;	<b>F8-6044</b>		H=160
Protective Cap/Bellow, shock absorber	RS3 quattro		<b>F8-6044</b>		H=160
Top Strut Mounting	All Models		<b>F8-6284</b>		
Top Strut Mounting	1.4 TFSI, 1.6, 1.6 FSI, 1.8 TFSI, 1.8 TFSI quattro, 1.9 TDI, 2.0, 2.0 FSI, 2.0 TDI, 2.0 TDI 16V, 2.0 TDI 16V quattro, 2.0 TDI quattro, 2.0 TFSI, 2.0 TFSI quattro, 3.2 V6 quattro	for OE: 1K0513353H; Shape Oval	<b>F8-6349</b>		
Belt Pulley, crankshaft	1.9 TDI, 2.0 TDI, 2.0 TDI 16V, 2.0 TDI 16V quattro, 2.0 TDI quattro	Number of Ribs: 5; Parameter: 6PK	<b>F8-6396</b>		H=41.6; d=30; Mounting points diam.[mm]=7, 8.6; D=139.7
Control Arm-/Trailing Arm Bush	1.4 TFSI, 1.6, 1.6 FSI, 1.6 TDI, 1.8 TFSI, 1.8 TFSI quattro, 1.9 TDI, 2.0, 2.0 FSI, 2.0 TDI, 2.0 TDI 16V, 2.0 TDI 16V quattro, 2.0 TDI quattro, 2.0 TFSI, 2.0 TFSI quattro, 3.2 V6 quattro	Aluminium	<b>F8-6424</b>		
Control Arm-/Trailing Arm Bush	1.4 TFSI, 1.6, 1.6 FSI, 1.6 TDI, 1.8 TFSI, 1.8 TFSI quattro, 1.9 TDI, 2.0, 2.0 FSI, 2.0 TDI, 2.0 TDI 16V, 2.0 TDI 16V quattro, 2.0 TDI quattro, 2.0 TFSI, 2.0 TFSI quattro, 3.2 V6 quattro	Aluminium	<b>F8-6425</b>		

<b>AK-735180</b>	<b>AK-735181</b>	<b>F5-1004</b>	<b>F5-1044</b>	<b>F5-1064</b>	<b>F5-1085</b>	<b>F8-5633</b>
Ref.Nr.: 1K0412303P	Ref.Nr.: 1K0511353J	Ref.Nr.: 038903119T	Ref.Nr.: 06B903119B	Ref.Nr.: 03C903119D	Ref.Nr.: 045903119A	Ref.Nr.: 1K0407182A
<b>F8-5650</b>	<b>F8-6044</b>	<b>F8-6284</b>	<b>F8-6349</b>	<b>F8-6396</b>	<b>F8-6424</b>	<b>F8-6425</b>
Ref.Nr.: 06A105243E	Ref.Nr.: 3C0513425	Ref.Nr.: 6N0412249C	Ref.Nr.: 1K0513353H	Ref.Nr.: 03G105243	Ref.Nr.: 1K0199232G	Ref.Nr.: 1K0199231J
<b>F8-6463</b>						
Ref.Nr.: 1K0505541B						



**Article Description****Article Nr.****Fitting Position**

<b>A3 Sportback (8PA)</b>				<b>09/2004 → 03/2013</b>	
Control Arm-/Trailing Arm Bush	1.4 TFSI, 1.6, 1.6 FSI, 1.6 TDI, 1.8 TFSI, 1.8 TFSI quattro, 1.9 TDI, 2.0, 2.0 FSI, 2.0 TDI, 2.0 TDI 16V, 2.0 TDI 16V quattro, 2.0 TDI quattro, 2.0 TFSI, 2.0 TFSI quattro, 3.2 V6 quattro, S3 quattro		<b>F8-6463</b>		H=64; d=12; D=60
Engine Mounting	2.0 TDI	AZV	<b>F8-6528</b>		
Engine Mounting	2.0 TDI 16V, 2.0 TDI 16V quattro	BKD	<b>F8-6528</b>		
Engine Mounting	2.0 TDI, 2.0 TDI quattro		<b>F8-6528</b>		
Engine Mounting	2.0 TDI, 2.0 TDI quattro	BMN	<b>F8-6528</b>		
Engine Mounting	1.6 FSI		<b>F8-6531</b>		H=117.7; L=165; W=149
Anti-Friction Bearing	All Models		<b>F8-6569</b>		
Top Strut Mounting	All Models		<b>F8-6570</b>		
Belt Pulley, crankshaft	1.6 TDI	Number of Ribs: 5; Parameter: 6PK	<b>F8-6572</b>		
Belt Pulley, crankshaft	2.0 TDI 16V	CFFB, CLJA; Number of Ribs: 5; Parameter: 6PK	<b>F8-6572</b>		
Belt Pulley, crankshaft	2.0 TDI 16V quattro	CFFB; Number of Ribs: 5; Parameter: 6PK	<b>F8-6572</b>		
Belt Pulley, crankshaft	2.0 TDI, 2.0 TDI quattro	CFGB; Number of Ribs: 5; Parameter: 6PK	<b>F8-6572</b>		
Engine Mounting	1.6		<b>F8-6988</b>		
Engine Mounting	1.8 TFSI, 1.8 TFSI quattro, 2.0 FSI, 2.0 TFSI, 2.0 TFSI quattro, S3 quattro		<b>F8-6989</b>		
Engine Mounting	3.2 V6 quattro	BMJ	<b>F8-7008</b>		
Rubber Buffer, suspension	1.6, 1.6 FSI, 1.9 TDI, 2.0 FSI, 2.0 TDI, 2.0 TDI 16V, 2.0 TFSI	ch.→8P-6A110320, 8P-6B011800; for OE: G35;	<b>F8-7131</b>		H=70
Rubber Buffer, suspension	1.6, 1.6 FSI, 2.0 FSI	for OE: G35;	<b>F8-7131</b>		H=70
Protective Cap/Bellow, shock absorber	1.2 TSI, 1.4 TFSI, 1.6, 1.6 E-Power, 1.6 FSI, 1.6 TDI, 1.8 TFSI, 1.8 TFSI quattro, 1.9 TDI, 2.0 FSI, 2.0 TDI, 2.0 TDI 16V, 2.0 TDI 16V quattro, 2.0 TDI quattro, 2.0 TFSI, 2.0 TFSI quattro, 3.2 V6 quattro, RS3 quattro, S3 quattro		<b>F8-7132</b>		H=190
Rubber Buffer, suspension	1.2 TSI, 1.4 TFSI, 1.6, 1.6 E-Power, 1.6 FSI, 1.6 TDI, 1.8 TFSI, 1.8 TFSI quattro, 1.9 TDI, 2.0, 2.0 FSI, 2.0 TDI, 2.0 TDI 16V, 2.0 TDI 16V quattro, 2.0 TDI quattro, 2.0 TFSI, 2.0 TFSI quattro, 3.2 V6 quattro	for OE: UA0; Shape Oval;	<b>F8-7579</b>		H=100
Rubber Buffer, suspension	1.2 TSI, 1.4 TFSI, 1.6, 1.6 E-Power, 1.6 FSI, 1.6 TDI, 1.8 TFSI, 1.8 TFSI quattro, 1.9 TDI, 2.0, 2.0 FSI, 2.0 TDI, 2.0 TDI 16V, 2.0 TDI 16V quattro, 2.0 TDI quattro, 2.0 TFSI, 2.0 TFSI quattro, 3.2 V6 quattro	for OE: UA1, UA9; Shape Oval;	<b>F8-7579</b>		H=100
Rubber Buffer, suspension	1.2 TSI, 1.4 TFSI, 1.6, 1.6 E-Power, 1.6 FSI, 1.6 TDI, 1.8 TFSI, 1.8 TFSI quattro, 1.9 TDI, 2.0, 2.0 FSI, 2.0 TDI, 2.0 TDI 16V, 2.0 TDI 16V quattro, 2.0 TDI quattro, 2.0 TFSI, 2.0 TFSI quattro, 3.2 V6 quattro	for OE: UA2; Shape Oval;	<b>F8-7579</b>		H=100

<b>F8-6463</b>	<b>F8-6528</b>	<b>F8-6531</b>	<b>F8-6569</b>	<b>F8-6570</b>	<b>F8-6572</b>	<b>F8-6988</b>
Ref.Nr.: 1K0505541B	Ref.Nr.: 1K0 199 262 AT	Ref.Nr.: 1K0199262T	Ref.Nr.: 6N0412249C	Ref.Nr.: 1K0412331C	Ref.Nr.: 038105243L	Ref.Nr.: 1K0199262AL
<b>F8-6989</b>	<b>F8-7008</b>	<b>F8-7131</b>	<b>F8-7132</b>	<b>F8-7579</b>		
Ref.Nr.: 1K0199262AM	Ref.Nr.: 1K0199262Q	Ref.Nr.: 1K0412303B	Ref.Nr.: 6N0413175A	Ref.Nr.: 1K0 511 353 J		

Article Description



Article Nr.

Fitting Position



### A3 Sportback (8PA)

09/2004 → 03/2013

Rubber Buffer, suspension	1.2 TSI, 1.4 TFSI, 1.6, 1.6 E-Power, 1.6 FSI, 1.6 TDI, 1.8 TFSI, 1.8 TFSI quattro, 1.9 TDI, 2.0, 2.0 FSI, 2.0 TDI, 2.0 TDI 16V, 2.0 TDI 16V quattro, 2.0 TDI quattro, 2.0 TFSI, 2.0 TFSI quattro, 3.2 V6 quattro	S line; for OE: UA3; Shape Oval	<b>F8-7579</b>		H=100
Top Strut Mounting	1.2 TSI, 1.4 TFSI, 1.6, 1.6 E-Power, 1.6 FSI, 1.6 TDI, 1.8 TFSI, 1.8 TFSI quattro, 1.9 TDI, 2.0, 2.0 FSI, 2.0 TDI, 2.0 TDI 16V, 2.0 TDI 16V quattro, 2.0 TDI quattro, 2.0 TFSI, 2.0 TFSI quattro, 3.2 V6 quattro, RS3 quattro, S3 quattro	for OE: 1K0513353R, 3C0513353C; Shape Round	<b>F8-7603</b>		
Protective Cap/Bellow, shock absorber	1.2 TSI, 1.4 TFSI, 1.6, 1.6 E-Power, 1.6 FSI, 1.6 TDI, 1.8 TFSI, 1.8 TFSI quattro, 1.9 TDI, 2.0, 2.0 FSI, 2.0 TDI, 2.0 TDI 16V, 2.0 TDI 16V quattro, 2.0 TDI quattro, 2.0 TFSI, 2.0 TFSI quattro, 3.2 V6 quattro	for OE: UA0; Shape Round; <b>ST</b>	<b>F8-7627</b>		H=178
Protective Cap/Bellow, shock absorber	1.2 TSI, 1.4 TFSI, 1.6, 1.6 E-Power, 1.6 FSI, 1.6 TDI, 1.8 TFSI, 1.8 TFSI quattro, 1.9 TDI, 2.0, 2.0 FSI, 2.0 TDI, 2.0 TDI 16V, 2.0 TDI 16V quattro, 2.0 TDI quattro, 2.0 TFSI, 2.0 TFSI quattro, 3.2 V6 quattro	for OE: UA2; Shape Round; <b>Δ</b>	<b>F8-7627</b>		H=178
Protective Cap/Bellow, shock absorber	1.2 TSI, 1.4 TFSI, 1.6, 1.6 E-Power, 1.6 FSI, 1.6 TDI, 1.8 TFSI, 1.8 TFSI quattro, 1.9 TDI, 2.0, 2.0 FSI, 2.0 TDI, 2.0 TDI 16V, 2.0 TDI 16V quattro, 2.0 TDI quattro, 2.0 TFSI, 2.0 TFSI quattro, 3.2 V6 quattro	S line; for OE: UA3; Shape Round	<b>F8-7627</b>		H=178
Protective Cap/Bellow, shock absorber	1.2 TSI, 1.4 TFSI, 1.6, 1.6 E-Power, 1.6 FSI, 1.6 TDI, 1.8 TFSI, 1.9 TDI, 2.0, 2.0 FSI, 2.0 TDI, 2.0 TDI 16V, 2.0 TFSI	for OE: UA1; Shape Round; <b>SP</b>	<b>F8-7627</b>		H=178
Protective Cap/Bellow, shock absorber	1.8 TFSI quattro, 2.0 TDI 16V quattro, 2.0 TDI quattro, 2.0 TFSI quattro, 3.2 V6 quattro	for OE: UA1, UA9; Shape Round; <b>SP</b>	<b>F8-7627</b>		H=178
Protective Cap/Bellow, shock absorber	2.0 TDI	Shape Round	<b>F8-7627</b>		H=178
Rubber Buffer, suspension	1.2 TSI, 1.4 TFSI, 1.6, 1.6 E-Power, 1.6 FSI, 1.6 TDI, 1.8 TFSI, 1.8 TFSI quattro, 1.9 TDI, 2.0 FSI, 2.0 TDI, 2.0 TDI 16V, 2.0 TDI 16V quattro, 2.0 TDI quattro, 2.0 TFSI, 2.0 TFSI quattro, 3.2 V6 quattro, RS3 quattro, S3 quattro	for OE: G12; <b>SP</b>	<b>F8-7697</b>		H=55
Rubber Buffer, suspension	1.2 TSI, 1.4 TFSI, 1.6, 1.6 FSI, 1.6 TDI, 1.8 TFSI, 1.8 TFSI quattro, 1.9 TDI, 2.0 FSI, 2.0 TDI, 2.0 TDI 16V, 2.0 TDI 16V quattro, 2.0 TDI quattro, 2.0 TFSI, 2.0 TFSI quattro, 3.2 V6 quattro, RS3 quattro, S3 quattro	ch.→8P-6A110320, 8P-6B011800; for OE: G38; <b>SP</b>	<b>F8-7697</b>		H=55
Rubber Buffer, suspension	1.2 TSI, 1.4 TFSI, 1.6, 1.6 FSI, 1.6 TDI, 1.8 TFSI, 1.8 TFSI quattro, 1.9 TDI, 2.0 FSI, 2.0 TDI, 2.0 TDI 16V, 2.0 TDI 16V quattro, 2.0 TDI quattro, 2.0 TFSI, 2.0 TFSI quattro, 3.2 V6 quattro, RS3 quattro, S3 quattro	ch.8P-6B011800→; ch.→8P-6A110320; for OE: G32; <b>SP</b>	<b>F8-7697</b>		H=55
Rubber Buffer, suspension	1.2 TSI, 1.4 TFSI, 1.6, 1.6 FSI, 1.6 TDI, 1.8 TFSI, 2.0, 2.0 FSI, 2.0 TDI, 2.0 TDI 16V, 2.0 TFSI	ch.8P-BA000001→; for OE: G17, G43; 2011→; <b>ST</b>	<b>F8-7831</b>		H=90
Rubber Buffer, suspension	1.6 TDI	for OE: G17, G43; 2011→; <b>ST</b>	<b>F8-7831</b>		H=90
Rubber Buffer, suspension	1.6, 1.6 FSI, 1.8 TFSI, 1.9 TDI, 2.0, 2.0 FSI, 2.0 TDI, 2.0 TDI 16V, 2.0 TFSI	ch.8P-4-130001→; for OE: G43; →2007; <b>ST</b>	<b>F8-7831</b>		H=90
Rubber Buffer, suspension	1.2 TSI, 1.4 TFSI, 1.6 TDI	for OE: G32, G38; <b>SP</b>	<b>F8-7832</b>		H=85



**Article Description****Article Nr.****Fitting Position**

<b>A3 Sportback (8PA)</b>		<b>09/2004 → 03/2013</b>			
Rubber Buffer, suspension	1.2 TSI, 1.4 TFSI, 1.6, 1.6 FSI, 1.6 TDI, 1.8 TFSI, 1.9 TDI, 2.0, 2.0 FSI, 2.0 TDI, 2.0 TDI 16V, 2.0 TFSI	ch.→8P-9B050000; for OE: G31; →2010; <b>ST</b>	<b>F8-7832</b>		H=85
Rubber Buffer, suspension	1.2 TSI, 1.4 TFSI, 1.6, 1.6 FSI, 1.6 TDI, 1.8 TFSI, 1.9 TDI, 2.0, 2.0 FSI, 2.0 TDI, 2.0 TDI 16V, 2.0 TFSI	ch.→8P-9B050000; for OE: G37; →2010; <b>ST</b>	<b>F8-7832</b>		H=85
Rubber Buffer, suspension	1.4 TFSI, 1.6, 1.6 FSI, 1.8 TFSI, 1.9 TDI, 2.0, 2.0 FSI, 2.0 TDI, 2.0 TDI 16V, 2.0 TFSI	ch.→8P-4-130000; for OE: G43; <b>ST</b>	<b>F8-7832</b>		H=85
Rubber Buffer, suspension	1.6, 1.6 FSI, 1.8 TFSI, 1.9 TDI, 2.0, 2.0 FSI, 2.0 TDI, 2.0 TDI 16V, 2.0 TFSI	ch.8P-4-020901→; for OE: G32, G38; <b>SP</b>	<b>F8-7832</b>		H=85
Rubber Buffer, suspension	1.8 TFSI quattro, 2.0 TDI 16V quattro, 2.0 TDI quattro, 2.0 TFSI quattro	ch.→8P-9B050000; for OE: G44; →2010; <b>ST</b>	<b>F8-7832</b>		H=85
Rubber Buffer, suspension	1.8 TFSI quattro, 2.0 TDI 16V quattro, 2.0 TDI quattro, 2.0 TFSI quattro, 3.2 V6 quattro, S3 quattro	ch.→8P-9B050000; for OE: G33; <b>SP</b>	<b>F8-7832</b>		H=85
Rubber Buffer, suspension	1.8 TFSI quattro, 2.0 TDI 16V quattro, 2.0 TDI quattro, 2.0 TFSI quattro, 3.2 V6 quattro, S3 quattro	ch.8P-7-081500→; ch.→8P-9B050000; for OE: G36; <b>SP</b>	<b>F8-7832</b>		H=85
Rubber Buffer, suspension	2.0 TDI	for OE: G31; <b>ST</b>	<b>F8-7832</b>		H=85
Rubber Buffer, suspension	2.0 TDI	for OE: G37; <b>ST</b>	<b>F8-7832</b>		H=85
Rubber Buffer, suspension	2.0 TDI quattro, 3.2 V6 quattro	for OE: G44; <b>ST</b>	<b>F8-7832</b>		H=85
Rubber Buffer, suspension	1.2 TSI, 1.4 TFSI, 1.6 TDI, 1.8 TFSI, 2.0, 2.0 TDI	for OE: G35; <b>ST</b>	<b>F8-7833</b>		H=86
Rubber Buffer, suspension	1.2 TSI, 1.4 TFSI, 1.6, 1.6 FSI, 1.6 TDI, 1.8 TFSI, 1.9 TDI, 2.0, 2.0 FSI, 2.0 TDI, 2.0 TDI 16V, 2.0 TFSI	for OE: G20; <b>SP</b>	<b>F8-7833</b>		H=86
Rubber Buffer, suspension	1.4 TFSI, 1.6, 1.6 FSI, 1.6 TDI, 1.8 TFSI, 1.9 TDI, 2.0, 2.0 FSI, 2.0 TDI, 2.0 TDI 16V, 2.0 TFSI	ch.→8P-9B050000; for OE: G17; →2010; <b>ST</b>	<b>F8-7833</b>		H=86
Rubber Buffer, suspension	1.4 TFSI, 1.6, 1.6 FSI, 1.6 TDI, 1.8 TFSI, 1.9 TDI, 2.0, 2.0 FSI, 2.0 TDI, 2.0 TDI 16V, 2.0 TFSI	ch.8P-8A000001→; ch.→8P-9B050000; for OE: G43; 2008→; →2010; <b>ST</b>	<b>F8-7833</b>		H=86
Rubber Buffer, suspension	1.6, 1.6 FSI, 1.9 TDI, 2.0 FSI, 2.0 TDI, 2.0 TDI 16V, 2.0 TFSI	ch.8P-6A110321, 8P-6B011801→; for OE: G35; <b>ST</b>	<b>F8-7833</b>		H=86
Rubber Buffer, suspension	2.0 TDI	for OE: G17; <b>ST</b>	<b>F8-7833</b>		H=86
Rubber Buffer, suspension	1.2 TSI, 1.4 TFSI, 1.6, 1.6 E-Power, 1.6 FSI, 1.6 TDI, 1.8 TFSI, 1.8 TFSI quattro, 1.9 TDI, 2.0, 2.0 FSI, 2.0 TDI, 2.0 TDI 16V, 2.0 TDI 16V quattro, 2.0 TDI quattro, 2.0 TFSI, 2.0 TFSI quattro, 3.2 V6 quattro	for OE: UA0; Shape Round; <b>ST</b>	<b>F8-7835</b>		H=75
Rubber Buffer, suspension	1.2 TSI, 1.4 TFSI, 1.6, 1.6 E-Power, 1.6 FSI, 1.6 TDI, 1.8 TFSI, 1.8 TFSI quattro, 1.9 TDI, 2.0, 2.0 FSI, 2.0 TDI, 2.0 TDI 16V, 2.0 TDI 16V quattro, 2.0 TDI quattro, 2.0 TFSI, 2.0 TFSI quattro, 3.2 V6 quattro	for OE: UA1, UA9; Shape Round; <b>SP</b>	<b>F8-7835</b>		H=75
Rubber Buffer, suspension	1.2 TSI, 1.4 TFSI, 1.6, 1.6 E-Power, 1.6 FSI, 1.6 TDI, 1.8 TFSI, 1.8 TFSI quattro, 1.9 TDI, 2.0, 2.0 FSI, 2.0 TDI, 2.0 TDI 16V, 2.0 TDI 16V quattro, 2.0 TDI quattro, 2.0 TFSI, 2.0 TFSI quattro, 3.2 V6 quattro	for OE: UA2; Shape Round; <b>Δ</b>	<b>F8-7835</b>		H=75
Rubber Buffer, suspension	1.2 TSI, 1.4 TFSI, 1.6, 1.6 E-Power, 1.6 FSI, 1.6 TDI, 1.8 TFSI, 1.8 TFSI quattro, 1.9 TDI, 2.0, 2.0 FSI, 2.0 TDI, 2.0 TDI 16V, 2.0 TDI 16V quattro, 2.0 TDI quattro, 2.0 TFSI, 2.0 TFSI quattro, 3.2 V6 quattro	S line; for OE: UA3; Shape Round	<b>F8-7835</b>		H=75
Belt Pulley, crankshaft	1.8 TFSI, 1.8 TFSI quattro, 2.0 TFSI, 2.0 TFSI quattro	Number of Ribs: 5; Parameter: 6PK	<b>F8-7880</b>		D=143



Article Description



Article Nr.

Fitting Position



### A3 Sportback (8PA)

09/2004 → 03/2013

Rubber Buffer, suspension	RS3 quattro, S3 quattro	for OE: UB5	<b>F8-7894</b>		
Control Arm-/Trailing Arm Bush	1.2 TFSI, 1.4 TFSI, 1.6, 1.6 E-Power, 1.6 FSI, 1.6 TDI, 1.8 TFSI, 1.8 TFSI quattro, 1.9 TDI, 2.0, 2.0 FSI, 2.0 TDI, 2.0 TDI 16V, 2.0 TDI 16V quattro, 2.0 TDI quattro, 2.0 TFSI, 2.0 TFSI quattro, 3.2 V6 quattro, S3 quattro		<b>F8-7902</b>		H=60; d=12; D=42
Control Arm-/Trailing Arm Bush	1.2 TFSI, 1.4 TFSI, 1.6, 1.6 E-Power, 1.6 FSI, 1.6 TDI, 1.8 TFSI, 1.8 TFSI quattro, 1.9 TDI, 2.0, 2.0 FSI, 2.0 TDI, 2.0 TDI 16V, 2.0 TDI 16V quattro, 2.0 TDI quattro, 2.0 TFSI, 2.0 TFSI quattro, 3.2 V6 quattro, S3 quattro		<b>F8-7907</b>		H=45; d=14; D=38
Control Arm-/Trailing Arm Bush	1.2 TFSI, 1.4 TFSI, 1.6, 1.6 E-Power, 1.6 FSI, 1.6 TDI, 1.8 TFSI, 1.8 TFSI quattro, 1.9 TDI, 2.0, 2.0 FSI, 2.0 TDI, 2.0 TDI 16V, 2.0 TDI 16V quattro, 2.0 TDI quattro, 2.0 TFSI, 2.0 TFSI quattro, 3.2 V6 quattro, S3 quattro		<b>F8-7908</b>		H=45; d=12; D=38
Control Arm-/Trailing Arm Bush	1.2 TFSI, 1.4 TFSI, 1.6, 1.6 E-Power, 1.6 FSI, 1.6 TDI, 1.8 TFSI, 1.8 TFSI quattro, 1.9 TDI, 2.0, 2.0 FSI, 2.0 TDI, 2.0 TDI 16V, 2.0 TDI 16V quattro, 2.0 TDI quattro, 2.0 TFSI, 2.0 TFSI quattro, 3.2 V6 quattro, S3 quattro		<b>F8-7909</b>		
Stabiliser Mounting	1.6, 1.6 FSI, 1.8 TFSI, 1.9 TDI, 2.0, 2.0 FSI, 2.0 TDI, 2.0 TDI 16V, 2.0 TDI 16V quattro, 2.0 TDI quattro, 2.0 TFSI, 2.0 TFSI quattro, 3.2 V6 quattro		<b>F8-7923</b>		d=20,7
Stabiliser Mounting	1.6, 1.6 FSI, 1.9 TDI, 2.0 FSI, 2.0 TDI, 2.0 TDI 16V, 2.0 TDI 16V quattro, 2.0 TDI quattro, 2.0 TFSI, 2.0 TFSI quattro		<b>F8-7930</b>		d=18,5
Engine Mounting	1.9 TDI		<b>F8-7958</b>		
Engine Mounting	1.4 TFSI	CAXC	<b>F8-7959</b>		
Engine Mounting	1.4 TFSI, 1.6		<b>F8-7960</b>		
Engine Mounting	1.6 FSI		<b>F8-7960</b>		
Engine Mounting	1.6, 2.0 FSI		<b>F8-7961</b>		
Engine Mounting	1.8 TFSI, 1.8 TFSI quattro	CDAA	<b>F8-7961</b>		
Engine Mounting	2.0 TFSI, 2.0 TFSI quattro	6-speed	<b>F8-7962</b>		
Engine Mounting	2.0, 2.0 TDI, 2.0 TDI 16V, 2.0 TDI 16V quattro, 2.0 TDI quattro		<b>F8-7962</b>		
Engine Mounting	1.2 TSI		<b>F8-7965</b>		
Engine Mounting	1.4 TFSI	CAXC;	<b>F8-7965</b>		
Engine Mounting	1.6	BGU, BSE, BSF, CCSA;	<b>F8-7965</b>		
Engine Mounting	1.6 FSI	BLF, BLP	<b>F8-7965</b>		
Engine Mounting	1.6	BGU, BSF;	<b>F8-7966</b>		
Engine Mounting	1.6	BSE;	<b>F8-7966</b>		
Engine Mounting	1.8 TFSI	BYT, BZB;  6-speed	<b>F8-7966</b>		

<b>F8-7894</b>	<b>F8-7902</b>	<b>F8-7907</b>	<b>F8-7908</b>	<b>F8-7909</b>	<b>F8-7923</b>	<b>F8-7930</b>
Ref.Nr.: 8J0511333F	Ref.Nr.: 1K0505171C	Ref.Nr.: 1K0505203A	Ref.Nr.: 1K0505279A	Ref.Nr.: 1K0505553 A	Ref.Nr.: 1K0511327AR	Ref.Nr.: 1K0511327AP
<b>F8-7958</b>	<b>F8-7959</b>	<b>F8-7960</b>	<b>F8-7961</b>	<b>F8-7962</b>	<b>F8-7965</b>	<b>F8-7966</b>
Ref.Nr.: 1K0199262AS	Ref.Nr.: 1K0199262CG	Ref.Nr.: 1K0199555L	Ref.Nr.: 1K0199555N	Ref.Nr.: 1K0199555Q	Ref.Nr.: 1K0199855BA	Ref.Nr.: 1K0199855BB



Article Description



Article Nr.

Fitting Position



**A3 Sportback (8PA)** 09/2004 → 03/2013

Engine Mounting	1.8 TFSI, 1.8 TFSI quattro	CDAA;  6-speed	<b>F8-7966</b>		
Engine Mounting	1.9 TDI, 2.0 FSI, 2.0 TDI, 2.0 TDI 16V, 2.0 TDI 16V quattro, 2.0 TDI quattro		<b>F8-7966</b>		
Engine Mounting	2.0 TFSI	AXX, BWA, CAWB	<b>F8-7966</b>		
Engine Mounting	2.0 TFSI quattro	AXX, BWA	<b>F8-7966</b>		
Engine Mounting	2.0 TFSI, 2.0 TFSI quattro	BWA;  6-speed,  6-speed	<b>F8-7966</b>		
Engine Mounting	2.0 TFSI, 2.0 TFSI quattro	CCZA;  6-speed	<b>F8-7966</b>		
Engine Mounting	2.0 TFSI, 2.0 TFSI quattro	CCZA;  6-speed	<b>F8-7966</b>		
Engine Mounting	S3 quattro	6-speed	<b>F8-7966</b>		
Engine Mounting	1.4 TFSI, 1.6, 2.0 TFSI quattro, 3.2 V6 quattro		<b>F8-7981</b>	↓	
Engine Mounting	1.8 TFSI	BYT, BZB	<b>F8-7981</b>	↓	
Engine Mounting	1.9 TDI	ch.→8P-8A-088000, 8P-8B-010500;  BKC, BXE	<b>F8-7981</b>	↓	
Engine Mounting	2.0 FSI		<b>F8-7981</b>	↓	
Engine Mounting	2.0 TDI	ch.→8P-6A-040000, 8P-6B-004250	<b>F8-7981</b>	↓	
Engine Mounting	2.0 TDI 16V, 2.0 TDI 16V quattro, 2.0 TDI quattro	ch.→8P-8A-088000, 8P-8B-010500	<b>F8-7981</b>	↓	
Engine Mounting	2.0 TFSI	AXX, BPY, BWA, CAWB, CBFA	<b>F8-7981</b>	↓	
Engine Mounting	1.2 TSI, 1.4 TFSI, 1.6 FSI, 1.6 TDI, 1.8 TFSI, 1.8 TFSI quattro, 2.0 TDI, 2.0 TFSI, RS3 quattro, S3 quattro		<b>F8-7982</b>	↑	
Engine Mounting	1.6	BGU, BSE, BSF, CCSA	<b>F8-7982</b>	↑	
Engine Mounting	1.9 TDI	ch.8P-8A-088001, 8P-8B-010501→	<b>F8-7982</b>	↑	
Engine Mounting	2.0 FSI	BLR, BLX, BLY, BVY, BVZ	<b>F8-7982</b>	↑	
Engine Mounting	2.0 TDI 16V	BKD, CBAB, CFFB	<b>F8-7982</b>	↑	
Engine Mounting	2.0 TDI 16V quattro, 2.0 TDI quattro	for OE: TL4	<b>F8-7982</b>	↑	
Engine Mounting	2.0 TDI quattro	ch.→8P-6A-040000	<b>F8-7982</b>	↑	
Engine Mounting	2.0 TFSI quattro	AXX, BWA, CCZA	<b>F8-7982</b>	↑	
Engine Mounting	3.2 V6 quattro	ch.→8P-9A-000000	<b>F8-7982</b>	↑	
Engine Mounting	S3 quattro	CDLA	<b>F8-7982</b>	↑	
Engine Mounting	2.0 TDI 16V quattro, 2.0 TDI quattro		<b>F8-8152</b>	⊕	
Engine Mounting	2.0, 2.0 TDI, 2.0 TDI 16V		<b>F8-8152</b>	⊕	

**A3 (8V1)** 04/2012 →

Rubber Buffer, suspension	1.2 TFSI, 1.4 TFSI, 1.6 TDI, 1.8 TFSI, 1.8 TFSI quattro, 2.0 TDI, 2.0 TDI quattro, S3 quattro	for OE: 2UC, G01, G02, G03, G04, G21, G22, G23, G24;	<b>F8-7131</b>	⊕ ⊕	H=70
Rubber Buffer, suspension	1.2 TFSI, 1.4 TFSI, 1.6 TDI, 1.8 TFSI, 1.8 TFSI quattro, 2.0 TDI, 2.0 TDI quattro	for OE: 2UA;	<b>F8-7174</b>	⊕ ⊕	H=80
Belt Pulley, crankshaft	S3 quattro	Number of Ribs: 5; Parameter: 6PK	<b>F8-7880</b>		D=143

<b>F8-7131</b>	<b>F8-7174</b>	<b>F8-7880</b>	<b>F8-7966</b>	<b>F8-7981</b>	<b>F8-7982</b>	<b>F8-8152</b>
Ref.Nr.: 1K0412303B	Ref.Nr.: 1K0412303M	Ref.Nr.: 06H105243F	Ref.Nr.: 1K0199855BB	Ref.Nr.: 1K0199867Q	Ref.Nr.: 1K0199868Q	Ref.Nr.: 1K0199555T

Article Description



Article Nr.

Fitting Position



### A3 Sportback (8VA)

09/2012 →

Rubber Buffer, suspension	1.4 TFSI, 1.8 TFSI, 2.0 TDI, 2.0 TDI quattro	for OE: 2UC, G01, G02, G03, G04, G21, G22, G23, G24; <b>SP</b>	<b>F8-7131</b>		H=70
Rubber Buffer, suspension	1.2 TFSI, 1.4 TFSI, 1.6 TDI, 1.8 TFSI, 1.8 TFSI quattro, 2.0 TDI, 2.0 TDI quattro	for OE: 2UA; <b>ST</b>	<b>F8-7174</b>		H=80
Belt Pulley, crankshaft	1.8 TFSI	Number of Ribs: 5; Parameter: 6PK	<b>F8-7880</b>		D=143

### A4 (8D2, B5)

11/1994 → 09/2001

Dust Cover Kit, shock absorber	1.6, 1.8, 1.8 T, 1.9 TDI, 2.4, 2.5 TDI, 2.6, 2.8		<b>AK-735040</b>		
Dust Cover Kit, shock absorber	1.6, 1.8, 1.8 quattro, 1.8 T, 1.8 T quattro, 1.9 TDI, 1.9 TDI quattro, 2.4, 2.4 quattro, 2.5 TDI, 2.5 TDI quattro, 2.6, 2.6 quattro, 2.8, 2.8 quattro		<b>AK-735101</b>		
Alternator Freewheel Clutch	1.6, 1.8, 1.8 quattro, 1.8 T, 1.8 T quattro		<b>F5-1002</b>		
Alternator Freewheel Clutch	1.6, 1.8, 1.8 quattro, 1.8 T, 1.8 T quattro, 1.9 TDI, 1.9 TDI quattro		<b>F5-1006</b>		
Alternator Freewheel Clutch	1.9 TDI, 1.9 TDI quattro		<b>F5-1008</b>		
Alternator Freewheel Clutch	1.6, 1.8		<b>F5-1044</b>		
Top Strut Mounting	All Models		<b>F8-3050</b>		H=37; d=12; D1=72; D2=86
Engine Mounting	1.6, 1.8, 1.8 quattro, 1.8 T, 1.8 T quattro		<b>F8-4019</b>		H=47; d=26; D1=48; D2=67
Engine Mounting	1.9 TDI	ch.→8D-T-100000; <b>MS</b>	<b>F8-4019</b>		H=47; d=26; D1=48; D2=67
Engine Mounting	1.9 TDI	ch.8D-T-100001→; 01/1996 →; <b>MS</b>	<b>F8-4019</b>		H=47; d=26; D1=48; D2=67
Engine Mounting	1.9 TDI quattro	ch.8D-T-100001→; <b>MS</b>	<b>F8-4019</b>		H=47; d=26; D1=48; D2=67
Control Arm-/Trailing Arm Bush	1.6	01/1995 →	<b>F8-4044</b>		H1=42; H2=50; d=12; D1=22; D2=40
Control Arm-/Trailing Arm Bush	1.6, 1.8 T, 1.8 T quattro, 1.9 TDI, 1.9 TDI quattro	for OE: 4D0407151E	<b>F8-4044</b>		H1=42; H2=50; d=12; D1=22; D2=40
Control Arm-/Trailing Arm Bush	1.8, 1.8 quattro, 1.8 T, 1.8 T quattro, 1.9 TDI, 1.9 TDI quattro, 2.4, 2.4 quattro, 2.5 TDI, 2.5 TDI quattro, 2.6, 2.6 quattro, 2.8, 2.8 quattro, S4 quattro		<b>F8-4044</b>		H1=42; H2=50; d=12; D1=22; D2=40
Control Arm-/Trailing Arm Bush	1.6	01/1995 →	<b>F8-4045</b>		H1=31; H2=60; d=12; D=50
Control Arm-/Trailing Arm Bush	1.6, 1.8 T, 1.8 T quattro, 1.9 TDI, 1.9 TDI quattro	for OE: 4D0407151E	<b>F8-4045</b>		H1=31; H2=60; d=12; D=50
Control Arm-/Trailing Arm Bush	1.8, 1.8 quattro, 1.8 T, 1.8 T quattro, 1.9 TDI, 1.9 TDI quattro, 2.4, 2.4 quattro, 2.5 TDI, 2.5 TDI quattro, 2.6, 2.6 quattro, 2.7 Bi Turbo quattro, 2.7 Turbo quattro, 2.8, 2.8 24V, 2.8 quattro, S4 quattro		<b>F8-4045</b>		H1=31; H2=60; d=12; D=50
Stabiliser Mounting	1.6, 1.8, 1.8 T, 1.9 TDI, 2.4, 2.5 TDI, 2.6, 2.8	<b>SP</b>	<b>F8-5063</b>		d=24.8; L=44
Stabiliser Mounting	1.6, 1.8, 1.8 quattro, 1.8 T, 1.8 T quattro, 1.9 TDI, 1.9 TDI quattro, 2.4, 2.4 quattro, 2.5 TDI, 2.5 TDI quattro, 2.6, 2.6 quattro, 2.8, 2.8 quattro, S4 quattro		<b>F8-5064</b>		H=44; d=27
Mounting, axle beam	1.6, 1.8, 1.8 T, 1.9 TDI, 2.4, 2.5 TDI, 2.6, 2.8		<b>F8-5343</b>		H=101; d1=12,3; D1=56,5
Rubber Buffer, engine mounting	2.4, 2.4 quattro, 2.6, 2.6 quattro, 2.8, 2.8 quattro		<b>F8-5524</b>		d=26; L=47; D=68



**Article Description****Article Nr.****Fitting Position**

<b>A4 (8D2, B5)</b>			<b>11/1994 → 09/2001</b>		
Mounting, radiator	1.6, 1.8, 1.8 quattro, 1.8 T, 1.8 T quattro, 1.9 TDI, 1.9 TDI quattro, 2.4, 2.4 quattro, 2.5 TDI, 2.5 TDI quattro, 2.6, 2.6 quattro, 2.8, 2.8 quattro, S4 quattro		<b>F8-5526</b>		d=15; D=40; Thick. [mm]=25
Engine Mounting	1.6, 1.8, 1.8 quattro, 1.8 T, 1.8 T quattro		<b>F8-5538</b>		
Control Arm-Trailing Arm Bush	1.6, 1.8, 1.8 T, 1.9 TDI, 2.4, 2.5 TDI, 2.6, 2.8	ch.8D-W-260130→	<b>F8-5542</b>		H=40; d=10; D=46
Control Arm-Trailing Arm Bush	1.8 quattro, 1.8 T quattro, 1.9 TDI quattro, 2.4 quattro, 2.5 TDI quattro, 2.6 quattro, 2.7 Bi Turbo quattro, 2.7 Turbo quattro, 2.8 quattro, S4 quattro	ch.8D-W-245001→	<b>F8-5542</b>		H=40; d=10; D=46
Engine Mounting	1.6, 1.8, 1.8 quattro, 1.8 T, 1.8 T quattro, 1.9 TDI, 1.9 TDI quattro		<b>F8-5565</b>		
Engine Mounting	2.4, 2.4 quattro, 2.6, 2.6 quattro, 2.8, 2.8 quattro		<b>F8-5567</b>		
Mounting, axle beam	1.6, 1.8, 1.8 T, 1.9 TDI, 2.4, 2.5 TDI, 2.6, 2.8		<b>F8-5573</b>		H=101; d=12.3; D=56.3
Mounting, automatic transmission	1.6, 1.8, 1.8 quattro, 1.8 T, 1.8 T quattro, 1.9 TDI	ch.8D-X-200001→	<b>F8-5574</b>		
Mounting, automatic transmission	1.6, 2.6 quattro	ch.8D-X-200001→; 02/1999 →	<b>F8-5574</b>		
Mounting, automatic transmission	1.6, 2.6 quattro	ch.8D-X-200001→; 02/1999 →	<b>F8-5574</b>		
Mounting, automatic transmission	1.8 T quattro	ch.8D-X-200001→;	<b>F8-5574</b>		
Mounting, automatic transmission	1.6, 1.8 T, 2.4 quattro, 2.8 quattro		<b>F8-5575</b>		H=72; D=71
Mounting, automatic transmission	1.8 quattro	ADR; Transmission Type: DJV	<b>F8-5575</b>		H=72; D=71
Mounting, automatic transmission	2.4	ch.4B-W-065001, 8D-W-080001, 8D-X-200001→; ch.→4B-W-065000;  5-speed	<b>F8-5575</b>		H=72; D=71
Mounting, automatic transmission	2.4 quattro	ch.8D-W-080001→; ch.→8D-W-080000;  AGA, ALF, APS	<b>F8-5575</b>		H=72; D=71
Mounting, automatic transmission	2.4, 2.6, 2.8	5-speed	<b>F8-5575</b>		H=72; D=71
Mounting, automatic transmission	2.5 TDI	AMX, APR, AQD; Transmission Type: CVT (Stepless)	<b>F8-5575</b>		H=72; D=71
Mounting, automatic transmission	2.5 TDI quattro	ch.8D-X-200001→; ch.→8D-W-080000	<b>F8-5575</b>		H=72; D=71
Mounting, automatic transmission	2.6 quattro	ch.8D-W-080001→; ch.→8D-W-080000	<b>F8-5575</b>		H=72; D=71
Mounting, automatic transmission	2.8 quattro	ch.8D-W-080001, 8D-X-200001→; ch.→8D-W-080000;  ACK, ALG, AMX, APR, AQD	<b>F8-5575</b>		H=72; D=71
Mounting, automatic transmission	2.4, 2.4 quattro, 2.5 TDI, 2.6, 2.6 quattro, 2.8, 2.8 quattro		<b>F8-5576</b>		

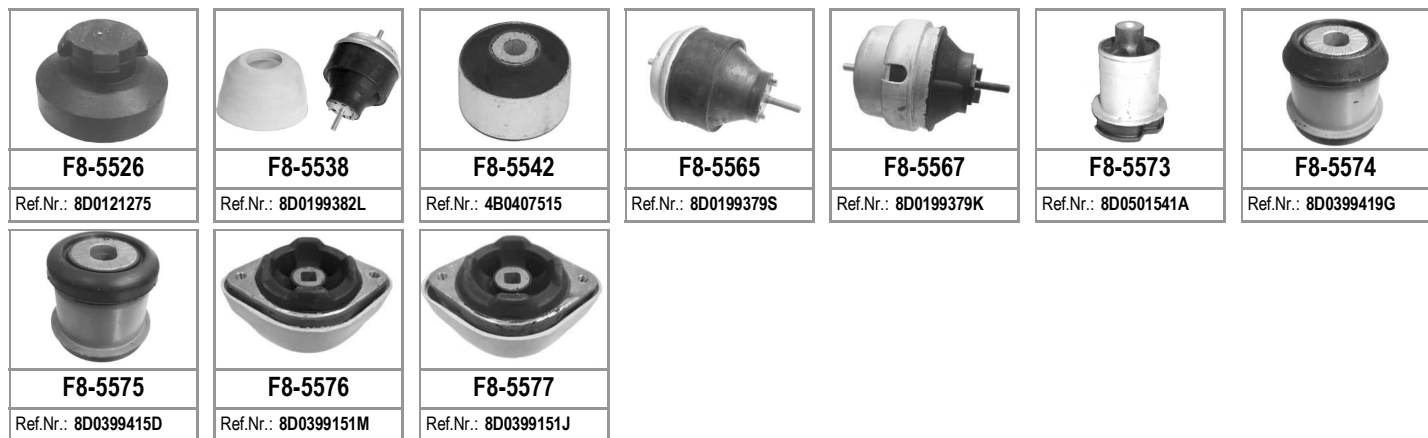

Article Description			Article Nr.	Fitting Position	
---------------------	--	--	-------------	------------------	--

A4 (8D2, B5)			11/1994 → 09/2001		
Mounting, automatic transmission	2.4, 2.4 quattro, 2.5 TDI, 2.5 TDI quattro, 2.6, 2.6 quattro, 2.7 Bi Turbo quattro, 2.7 Turbo quattro, S4 quattro		F8-5577	⊕ ⊕ ↓	
Mounting, automatic transmission	2.8, 2.8 quattro		F8-5577	⊕	
Mounting, automatic transmission	2.8, 2.8 quattro		F8-5577		
Mounting, manual transmission	1.8, 1.8 quattro, 1.8 T, 1.8 T quattro, 1.9 TDI, 1.9 TDI quattro, 2.8, 2.8 quattro		F8-5578	⊕	
Engine Mounting	1.6	ch.8D-V-058896→	F8-5579	⊕	
Engine Mounting	1.9 TDI, 1.9 TDI quattro		F8-5579	⊕	
Belt Pulley, crankshaft	1.9 TDI, 1.9 TDI quattro	ch.→8D1200000	F8-5654		
Rubber Buffer, suspension	1.6, 1.8, 1.8 T, 1.9 TDI, 2.4, 2.5 TDI, 2.6, 2.8	ch.→8D-X-199 999; <b>SP</b>	F8-5992	⊕ ⊕	H=112
Rubber Buffer, suspension	1.6, 1.8, 1.8 quattro, 1.8 T, 1.8 T quattro, 1.9 TDI, 1.9 TDI quattro, 2.4, 2.4 quattro, 2.5 TDI, 2.5 TDI quattro, 2.6, 2.6 quattro, 2.7 Turbo quattro, 2.8, 2.8 quattro, S4 quattro		F8-5994	⊕ ⊕	H=85
Rubber Buffer, suspension	1.6, 1.8, 1.8 quattro, 1.8 T, 1.8 T quattro, 1.9 TDI, 1.9 TDI quattro, 2.4, 2.4 quattro, 2.5 TDI, 2.5 TDI quattro, 2.6, 2.6 quattro, 2.7 Turbo quattro, 2.8, 2.8 quattro	<b>SP</b>	F8-6039	⊕ ⊕	H=77
Spring Cap	1.6, 1.8, 1.8 quattro, 1.8 T, 1.8 T quattro, 1.9 TDI, 1.9 TDI quattro, 2.4, 2.4 quattro, 2.5 TDI, 2.5 TDI quattro, 2.6, 2.6 quattro, 2.8, 2.8 quattro, S4 quattro	ch.→8D-W-012334	F8-6282		
Spring Cap	1.6, 1.8, 1.8 quattro, 1.8 T, 1.8 T quattro, 1.9 TDI, 1.9 TDI quattro, 2.4, 2.4 quattro, 2.5 TDI, 2.5 TDI quattro, 2.6, 2.6 quattro, 2.8, 2.8 quattro, S4 quattro	ch.8D-W-012335→	F8-6283		
Repair Kit, suspension strut	1.6, 1.8, 1.8 T, 1.9 TDI, 2.4, 2.5 TDI, 2.6, 2.8	ch.→8D-X-199999	F8-6346		
Top Strut Mounting	1.6, 1.8, 1.8 T, 1.9 TDI, 2.4, 2.5 TDI, 2.6, 2.8	ch.8D-X-200001→	F8-6347		
Belt Pulley, crankshaft	1.9 TDI	ch.8D-X-200001→; Number of Ribs: 7	F8-6391		
Belt Pulley, crankshaft	1.9 TDI quattro	ch.8D-X-200001→; Number of Ribs: 7; Type: ATJ	F8-6391		
Engine Mounting	2.5 TDI, 2.5 TDI quattro		F8-6530	⊕ ⊕	
Rubber Buffer, engine mounting	2.5 TDI, 2.5 TDI quattro	ch.→8D1200000	F8-6758		
Repair Kit, suspension strut	1.6, 1.8, 1.8 quattro, 1.8 T, 1.8 T quattro, 1.9 TDI, 1.9 TDI quattro, 2.4, 2.4 quattro, 2.5 TDI, 2.5 TDI quattro, 2.6, 2.6 quattro, 2.8, 2.8 quattro, S4 quattro	ch.→8D-W-012334	F8-7096		
Repair Kit, suspension strut	1.6, 1.8, 1.8 quattro, 1.8 T, 1.8 T quattro, 1.9 TDI, 1.9 TDI quattro, 2.4, 2.4 quattro, 2.5 TDI, 2.5 TDI quattro, 2.6, 2.6 quattro, 2.8, 2.8 quattro, S4 quattro	ch.8D-W-012335→	F8-7097		
Top Strut Mounting	1.6, 1.8, 1.8 T, 1.9 TDI, 2.4, 2.5 TDI, 2.6, 2.8	for OE: 8D0512333	F8-7100	↓	
Top Strut Mounting	1.6, 1.8, 1.8 T, 1.9 TDI, 2.4, 2.5 TDI, 2.6, 2.8	for OE: 8D0512335	F8-7101	↑	

<b>F8-5577</b>	<b>F8-5578</b>	<b>F8-5579</b>	<b>F8-5654</b>	<b>F8-5992</b>	<b>F8-5994</b>	<b>F8-6039</b>
Ref.Nr.: 8D0399151J	Ref.Nr.: 8D0399151H	Ref.Nr.: 8D0199382G	Ref.Nr.: 028105243Q	Ref.Nr.: 8D0512131	Ref.Nr.: 8D0412131F	Ref.Nr.: 8D0412131E
<b>F8-6282</b>	<b>F8-6283</b>	<b>F8-6346</b>	<b>F8-6347</b>	<b>F8-6391</b>	<b>F8-6530</b>	<b>F8-6758</b>
Ref.Nr.: 8D0412065	Ref.Nr.: 8D0412065E	Ref.Nr.: 8D0512335S	Ref.Nr.: 8D0512099A	Ref.Nr.: 038105243F	Ref.Nr.: 4B0 199 379 E	Ref.Nr.: 8D0199339E
<b>F8-7096</b>	<b>F8-7097</b>	<b>F8-7100</b>	<b>F8-7101</b>	<b>F8-7148</b>		
Ref.Nr.: 8D0412065	Ref.Nr.: 8D0412065D	Ref.Nr.: 8D0512333	Ref.Nr.: 8D0512335	Ref.Nr.: 4D0419831A		



**Article Description****Article Nr.****Fitting Position**

<b>A4 (8D2, B5)</b>		<b>11/1994 → 09/2001</b>			
Bellow, steering	1.8 T, 1.8 T quattro, 2.4, 2.4 quattro, 2.5 TDI, 2.5 TDI quattro, 2.6, 2.6 quattro, 2.8, 2.8 quattro, S4 quattro	for vehicles with steering damper	<b>F8-7148</b>		H=141; d1=65; d2=65
Control Arm-/Trailing Arm Bush	1.8 quattro, 1.8 T quattro, 1.9 TDI quattro, 2.4 quattro, 2.5 TDI quattro, 2.6 quattro, 2.8 quattro, S4 quattro	for OE: 8A0505323A, 8A0505323B, 8A0505324B, 8D0505323A, 8D0505323B, 8D0505324B	<b>F8-7149</b>		
Protective Cap/Bellow, shock absorber	1.6, 1.8, 1.8 quattro, 1.8 T, 1.8 T quattro, 1.9 TDI, 1.9 TDI quattro, 2.4, 2.4 quattro, 2.5 TDI, 2.5 TDI quattro, 2.6, 2.6 quattro, 2.8, 2.8 quattro, S4 quattro		<b>F8-7687</b>		H=80
Rubber Buffer, suspension	1.6, 1.8, 1.8 T, 1.9 TDI, 2.4, 2.5 TDI, 2.6, 2.8	ch.→8D-X-199 999;	<b>F8-7693</b>		H=127
Control Arm-/Trailing Arm Bush	1.6, 1.8, 1.8 quattro, 1.8 T, 1.8 T quattro, 1.9 TDI, 1.9 TDI quattro, 2.4, 2.4 quattro, 2.5 TDI, 2.5 TDI quattro, 2.6, 2.6 quattro, 2.8, 2.8 quattro	ch.8D-X-200001→; for OE: 1BV;	<b>F8-7796</b>		H=40; d=10; D=46,5
Control Arm-/Trailing Arm Bush	1.6, 1.8, 1.9 TDI, 1.9 TDI quattro, 2.8 24V	for OE: 1BV;	<b>F8-7796</b>		H=40; d=10; D=46,5
Control Arm-/Trailing Arm Bush	S4 quattro		<b>F8-7796</b>		H=40; d=10; D=46,5
Control Arm-/Trailing Arm Bush	1.8 quattro, 1.8 T quattro, 1.9 TDI quattro, 2.4 quattro, 2.5 TDI quattro, 2.6 quattro, 2.7 Bi Turbo quattro, 2.7 Turbo quattro, 2.8 quattro, S4 quattro		<b>F8-7924</b>		
Mounting, manual transmission	2.4, 2.5 TDI, 2.5 TDI quattro, 2.8, 2.8 24V		<b>F8-7971</b>		
Mounting, manual transmission	2.4, 2.8	ch.8D-X-200001→;	<b>F8-7971</b>		
Mounting, manual transmission	2.5 TDI	Transmission Nr: DQS, DSE, FRF;	<b>F8-7971</b>		
Mounting, manual transmission	2.5 TDI quattro	Transmission Nr: DQT;	<b>F8-7971</b>		
Mounting, automatic transmission	1.6	ch.8D-X-200 001→;  ANA;	<b>F8-8012</b>		H=66; D=71
Mounting, automatic transmission	1.8	ch.8D-X-200 001→;	<b>F8-8012</b>		H=66; D=71
Mounting, automatic transmission	1.8 T	ch.8D-X-200 001→;  APU;	<b>F8-8012</b>		H=66; D=71
Mounting, automatic transmission	1.9 TDI	AFN	<b>F8-8012</b>		H=66; D=71
Mounting, automatic transmission	1.8 T, 2.4, 2.4 quattro, 2.5 TDI, 2.5 TDI quattro, 2.6, 2.8, 2.8 quattro		<b>F8-8179</b>		
Suspension Kit	1.6, 1.8, 1.8 quattro, 1.8 T, 1.8 T quattro, 1.9 TDI, 1.9 TDI quattro, 2.4, 2.4 quattro, 2.5 TDI, 2.5 TDI quattro, 2.6, 2.6 quattro, 2.8, 2.8 quattro, S4 quattro	ch.8D-V-152088→	<b>G8-529</b>		
Control Arm-/Trailing Arm Bush	1.6	01/1995 →	<b>G9-615</b>		H1=66; H2=80; d=12; D=65
Control Arm-/Trailing Arm Bush	1.8, 1.8 quattro, 1.8 T, 1.8 T quattro, 1.9 TDI, 1.9 TDI quattro, 2.4, 2.4 quattro, 2.5 TDI, 2.5 TDI quattro, 2.6, 2.6 quattro, 2.8, 2.8 quattro, S4 quattro		<b>G9-615</b>		H1=66; H2=80; d=12; D=65
Control Arm-/Trailing Arm Bush	1.6	01/1995 →	<b>G9-616</b>		H1=26; H2=40; d=10; D1=24; D2=46

<b>F8-7148</b>	<b>F8-7149</b>	<b>F8-7687</b>	<b>F8-7693</b>	<b>F8-7796</b>	<b>F8-7924</b>	<b>F8-7971</b>
Ref.Nr.: 4D0419831A	Ref.Nr.: 8A0505185	Ref.Nr.: 4D0412137B	Ref.Nr.: 8D5512131F	Ref.Nr.: 8D0407515C	Ref.Nr.: 8D0505171	Ref.Nr.: 4B0399151M
<b>F8-8012</b>	<b>F8-8179</b>	<b>G8-529</b>	<b>G9-615</b>	<b>G9-616</b>		
Ref.Nr.: 8D0399415E	Ref.Nr.: 8D0399151R	Ref.Nr.: 8D0498998	Ref.Nr.: 4D0407183N	Ref.Nr.: 4D0407515		

Article Description



Article Nr.

Fitting Position



### A4 (8D2, B5)

11/1994 → 09/2001

Control Arm-/Trailing Arm Bush	1.6, 1.8, 1.8 quattro, 1.8 T, 1.8 T quattro, 1.9 TDI, 1.9 TDI quattro, 2.4, 2.4 quattro, 2.5 TDI, 2.5 TDI quattro, 2.6, 2.6 quattro, 2.8, 2.8 quattro, S4 quattro		G9-616		H1=26; H2=40; d=10; D1=24; D2=46
Bellow, steering	1.6, 1.8, 1.8 quattro, 1.8 T, 1.8 T quattro, 1.9 TDI, 1.9 TDI quattro, 2.4	ch.→8D-X-053000; ; with clamps;	LM-10005S		d1=18; d2=54; L [mm]=200
Bellow, steering	1.6, 1.8, 1.8 quattro, 1.8 T, 1.8 T quattro, 1.9 TDI, 1.9 TDI quattro, 2.4	ch.→8D-X-053000; ; with clamps;	LM-10005S		d1=18; d2=54; L [mm]=200
Bellow, steering	1.6, 1.8, 1.8 quattro, 1.8 T, 1.8 T quattro, 1.9 TDI, 1.9 TDI quattro, 2.6	ch.→8D-X-053000; ; with clamps;	LM-10005S		d1=18; d2=54; L [mm]=200
Bellow, steering	1.6, 1.8, 1.8 quattro, 1.8 T, 1.8 T quattro, 1.9 TDI, 1.9 TDI quattro, 2.6	ch.→8D-X-053000; ; with clamps;	LM-10005S		d1=18; d2=54; L [mm]=200
Bellow, steering	1.8	ch.→3B-XE376641, 3B-XP319680, 8D-X-053000; ; with clamps;	LM-10005S		d1=18; d2=54; L [mm]=200
Bellow, steering	1.8, 1.8 T	ch.→3B-XE376641, 3B-XP319680, 8D-X-053000; ; with clamps;	LM-10005S		d1=18; d2=54; L [mm]=200
Bellow, steering	1.8, 1.8 T	ch.→3B-XE376641, 3B-XP319680, 8D-X-053000; ; with clamps;	LM-10005S		d1=18; d2=54; L [mm]=200
Bellow, steering	2.4, 2.4 quattro, 2.5 TDI, 2.5 TDI quattro, 2.6, 2.6 quattro, 2.8, 2.8 quattro, S4 quattro	ch.→8D-X-053000; with clamps;	LM-10005S		d1=18; d2=54; L [mm]=200
Bellow, steering	2.8, 2.8 quattro	with clamps;	LM-10005S		d1=18; d2=54; L [mm]=200
Bellow, steering	1.6, 1.8, 1.8 quattro, 1.8 T, 1.8 T quattro, 1.9 TDI, 1.9 TDI quattro	ch.8D-X-053001→; ; with clamps;	LM-10021S		d1=20; d2=63; L [mm]=254
Bellow, steering	1.6, 1.8, 1.8 quattro, 1.8 T, 1.8 T quattro, 1.9 TDI, 1.9 TDI quattro	ch.8D-X-053001→; ; with clamps;	LM-10021S		d1=20; d2=63; L [mm]=254
Bellow, steering	1.6, 1.8, 1.8 quattro, 1.8 T, 1.8 T quattro, 1.9 TDI, 1.9 TDI quattro	ch.8D-X-053001→; ; with clamps;	LM-10021S		d1=20; d2=63; L [mm]=254
Bellow, steering	1.6, 1.8, 1.9 TDI, 1.9 TDI quattro	; with clamps;	LM-10021S		d1=20; d2=63; L [mm]=254
Bellow, steering	1.6, 1.8, 1.9 TDI, 1.9 TDI quattro	; with clamps;	LM-10021S		d1=20; d2=63; L [mm]=254
Bellow, steering	2.4, 2.4 quattro, 2.5 TDI, 2.5 TDI quattro, 2.6, 2.6 quattro, 2.7 Turbo quattro, 2.8, 2.8 quattro, S4 quattro	ch.8D-X-303810→; ; with clamps;	LM-10021S		d1=20; d2=63; L [mm]=254
Bellow, steering	2.4, 2.4 quattro, 2.5 TDI, 2.5 TDI quattro, 2.6, 2.6 quattro, 2.7 Turbo quattro, 2.8, 2.8 quattro, S4 quattro	ch.8D-Y-005049→; ; with clamps;	LM-10021S		d1=20; d2=63; L [mm]=254

### A4 Avant (8D5, B5)

11/1994 → 09/2001

Dust Cover Kit, shock absorber	1.6, 1.8, 1.8 T, 1.8 T quattro, 1.9 TDI, 2.5 TDI, 2.6, 2.8		AK-735040		
Dust Cover Kit, shock absorber	1.6, 1.8, 1.8 quattro, 1.8 T, 1.8 T quattro, 1.9 TDI, 1.9 TDI quattro, 2.4, 2.4 quattro, 2.5 TDI, 2.5 TDI quattro, 2.6, 2.6 quattro, 2.8, 2.8 quattro		AK-735101		
Alternator Freewheel Clutch	1.6, 1.8, 1.8 quattro, 1.8 T, 1.8 T quattro		F5-1002		
Alternator Freewheel Clutch	1.6, 1.8, 1.8 quattro, 1.8 T, 1.8 T quattro, 1.9 DUO, 1.9 TDI, 1.9 TDI quattro		F5-1006		
Alternator Freewheel Clutch	1.9 DUO, 1.9 TDI, 1.9 TDI quattro		F5-1008		
Alternator Freewheel Clutch	1.6		F5-1044		
Top Strut Mounting	All Models		F8-3050		H=37; d=12; D1=72; D2=86

<b>AK-735040</b>	<b>AK-735101</b>	<b>F5-1002</b>	<b>F5-1006</b>	<b>F5-1008</b>	<b>F5-1044</b>	<b>F8-3050</b>
Ref.Nr.: 357513425	Ref.Nr.: 4D0412137C	Ref.Nr.: 038903119P	Ref.Nr.: 038903119M	Ref.Nr.: 028903119AN	Ref.Nr.: 06B903119B	Ref.Nr.: 4D0412377D
<b>F8-4019</b>	<b>G9-616</b>	<b>LM-10005S</b>	<b>LM-10021S</b>			
Ref.Nr.: 893199339	Ref.Nr.: 4D0407515	Ref.Nr.: 4D0419831B	Ref.Nr.: 8D0419831K			

**Article Description****Article Nr.****Fitting Position**

<b>A4 Avant (8D5, B5)</b>			<b>11/1994 → 09/2001</b>	
Engine Mounting	1.6, 1.8, 1.8 quattro, 1.8 T, 1.8 T quattro		<b>F8-4019</b>	H=47; d=26; D1=48; D2=67
Engine Mounting	1.9 TDI	ch.→8D-T-100000;	<b>F8-4019</b>	H=47; d=26; D1=48; D2=67
Engine Mounting	1.9 TDI, 1.9 TDI quattro	ch.8D-T-100001→;	<b>F8-4019</b>	H=47; d=26; D1=48; D2=67
Control Arm-/Trailing Arm Bush	1.6	03/1996 →	<b>F8-4044</b>	H1=42; H2=50; d=12; D1=22; D2=40
Control Arm-/Trailing Arm Bush	1.6, 1.8 T, 1.8 T quattro, 1.9 TDI, 1.9 TDI quattro, 2.8, 2.8 quattro, RS4 quattro	for OE: 4D0407151E	<b>F8-4044</b>	H1=42; H2=50; d=12; D1=22; D2=40
Control Arm-/Trailing Arm Bush	1.8, 1.8 quattro, 1.8 T, 1.8 T quattro, 1.9 TDI, 1.9 TDI quattro, 2.4, 2.4 quattro, 2.5 TDI, 2.5 TDI quattro, 2.6, 2.6 quattro, 2.8, 2.8 quattro, S4 quattro		<b>F8-4044</b>	H1=42; H2=50; d=12; D1=22; D2=40
Control Arm-/Trailing Arm Bush	1.6	03/1996 →	<b>F8-4045</b>	H1=31; H2=60; d=12; D=50
Control Arm-/Trailing Arm Bush	1.6, 1.8 T, 1.8 T quattro, 1.9 TDI, 1.9 TDI quattro, 2.8, 2.8 quattro, RS4 quattro	for OE: 4D0407151E	<b>F8-4045</b>	H1=31; H2=60; d=12; D=50
Control Arm-/Trailing Arm Bush	1.8, 1.8 quattro, 1.8 T, 1.8 T quattro, 1.9 DUO, 1.9 TDI, 1.9 TDI quattro, 2.4, 2.4 quattro, 2.5 TDI, 2.5 TDI quattro, 2.6, 2.6 quattro, 2.8, 2.8 quattro, S4 quattro		<b>F8-4045</b>	H1=31; H2=60; d=12; D=50
Stabiliser Mounting	1.6, 1.8, 1.8 quattro, 1.8 T, 1.8 T quattro, 1.9 TDI, 1.9 TDI quattro, 2.4, 2.4 quattro, 2.5 TDI, 2.5 TDI quattro, 2.6, 2.6 quattro, 2.8, 2.8 quattro, S4 quattro		<b>F8-5064</b>	H=44; d=27
Mounting, axle beam	1.6, 1.8, 1.8 T, 1.9 TDI, 2.4, 2.5 TDI, 2.6, 2.8		<b>F8-5343</b>	H=101; d1=12.3; D1=56.5
Rubber Buffer, engine mounting	2.4, 2.4 quattro, 2.6, 2.6 quattro, 2.8, 2.8 quattro		<b>F8-5524</b>	d=26; L=47; D=68
Mounting, radiator	All Models		<b>F8-5526</b>	d=15; D=40; Thick. [mm]=25
Engine Mounting	1.6, 1.8, 1.8 quattro, 1.8 T, 1.8 T quattro		<b>F8-5538</b>	
Control Arm-/Trailing Arm Bush	1.6, 1.8, 1.8 T, 1.9 DUO, 1.9 TDI, 2.4, 2.5 TDI, 2.6, 2.8	ch.8D-W-260130→	<b>F8-5542</b>	H=40; d=10; D=46
Control Arm-/Trailing Arm Bush	1.8 quattro, 1.8 T quattro, 1.9 TDI quattro, 2.4 quattro, 2.5 TDI quattro, 2.6 quattro, 2.8 quattro, RS4 quattro, S4 quattro	ch.8D-W-245001→	<b>F8-5542</b>	H=40; d=10; D=46
Engine Mounting	1.6, 1.8, 1.8 quattro, 1.8 T, 1.8 T quattro, 1.9 DUO, 1.9 TDI, 1.9 TDI quattro		<b>F8-5565</b>	
Engine Mounting	2.4, 2.4 quattro, 2.6, 2.6 quattro, 2.8, 2.8 quattro		<b>F8-5567</b>	
Mounting, axle beam	1.6, 1.8, 1.8 T, 1.9 TDI, 2.4, 2.5 TDI, 2.6, 2.8		<b>F8-5573</b>	H=101; d=12.3; D=56.3
Mounting, automatic transmission	1.6, 1.8, 1.8 quattro, 1.8 T, 1.8 T quattro, 1.9 TDI	ch.8D-X-200001→	<b>F8-5574</b>	
Mounting, automatic transmission	1.8 T quattro	ch.8D-X-200001→;	<b>F8-5574</b>	
Mounting, automatic transmission	1.6, 1.8 T, 2.4 quattro, 2.5 TDI		<b>F8-5575</b>	H=72; D=71
Mounting, automatic transmission	1.8 quattro	ch.4B-W-056741→; ch.→4B-W-056740;  ADR; Transmission Type: DJV	<b>F8-5575</b>	H=72; D=71
Mounting, automatic transmission	1.8 T	ch.4B-W-056741→; ch.→4B-W-056740	<b>F8-5575</b>	H=72; D=71



Article Description



Article Nr.

Fitting Position



**A4 Avant (8D5, B5)**

11/1994 → 09/2001

Mounting, automatic transmission	2.4 quattro	ch.4B-W-056741, 8D-W-080001→; ch.→4B-W-056740, 8D-W-080000;  AGA, ALF, APS	<b>F8-5575</b>		H=72; D=71
Mounting, automatic transmission	2.4, 2.6, 2.8	5-speed	<b>F8-5575</b>		H=72; D=71
Mounting, automatic transmission	2.5 TDI quattro	Transmission Type: CVT (Stepless)	<b>F8-5575</b>		H=72; D=71
Mounting, automatic transmission	2.6 quattro	ch.→8D-W-080000	<b>F8-5575</b>		H=72; D=71
Mounting, automatic transmission	2.8 quattro	ch.4B-W-056741→; ch.→4B-W-056740;  APR, AQD	<b>F8-5575</b>		H=72; D=71
Mounting, automatic transmission	2.8 quattro	ch.8D-W-080001→; ch.→8D-W-080000;  ACK, ALG, AMX, APR, AQD;  5-speed	<b>F8-5575</b>		H=72; D=71
Mounting, automatic transmission	2.4, 2.4 quattro, 2.5 TDI, 2.6, 2.6 quattro, 2.8, 2.8 quattro		<b>F8-5576</b>		
Mounting, automatic transmission	2.4, 2.4 quattro, 2.5 TDI, 2.5 TDI quattro, 2.6, 2.6 quattro, RS4 quattro, S4 quattro		<b>F8-5577</b>		
Mounting, automatic transmission	2.8, 2.8 quattro		<b>F8-5577</b>		
Mounting, automatic transmission	2.8, 2.8 quattro		<b>F8-5577</b>		
Mounting, manual transmission	1.8, 1.8 quattro, 1.8 T, 1.8 T quattro, 1.9 TDI, 1.9 TDI quattro, 2.8, 2.8 quattro		<b>F8-5578</b>		
Engine Mounting	1.6	ch.8D-V-058896→	<b>F8-5579</b>		
Engine Mounting	1.9 DUO, 1.9 TDI, 1.9 TDI quattro		<b>F8-5579</b>		
Belt Pulley, crankshaft	1.9 TDI, 1.9 TDI quattro	ch.→8D1200000	<b>F8-5654</b>		
Rubber Buffer, suspension	1.6, 1.8, 1.8 T, 1.9 DUO, 1.9 TDI, 2.4, 2.5 TDI, 2.6, 2.8	ch.→8D-X-199 999;	<b>F8-5992</b>		H=112
Rubber Buffer, suspension	All Models		<b>F8-5994</b>		H=85
Rubber Buffer, suspension	1.6, 1.8, 1.8 quattro, 1.8 T, 1.8 T quattro, 1.9 DUO, 1.9 TDI, 1.9 TDI quattro, 2.4, 2.4 quattro, 2.5 TDI, 2.5 TDI quattro, 2.6, 2.6 quattro, 2.8, 2.8 quattro		<b>F8-6039</b>		H=77
Spring Cap	1.6, 1.8, 1.8 quattro, 1.8 T, 1.8 T quattro, 1.9 DUO, 1.9 TDI, 1.9 TDI quattro, 2.4, 2.4 quattro, 2.5 TDI, 2.5 TDI quattro, 2.6, 2.6 quattro, 2.8, 2.8 quattro, S4 quattro	ch.→8D-W-012334	<b>F8-6282</b>		
Spring Cap	1.6, 1.8, 1.8 quattro, 1.8 T, 1.8 T quattro, 1.9 DUO, 1.9 TDI, 1.9 TDI quattro, 2.4, 2.4 quattro, 2.5 TDI, 2.5 TDI quattro, 2.6, 2.6 quattro, 2.8, 2.8 quattro, RS4 quattro, S4 quattro	ch.8D-W-012335→	<b>F8-6283</b>		
Repair Kit, suspension strut	1.6, 1.8, 1.8 T, 1.9 DUO, 1.9 TDI, 2.4, 2.5 TDI, 2.6, 2.8	ch.→8D-X-199999	<b>F8-6346</b>		
Top Strut Mounting	1.6, 1.8, 1.8 T, 1.9 DUO, 1.9 TDI, 2.4, 2.6, 2.8	ch.8D-X-200001→	<b>F8-6347</b>		
Belt Pulley, crankshaft	1.9 TDI	ch.8D-X-200001→; Number of Ribs: 7	<b>F8-6391</b>		
Belt Pulley, crankshaft	1.9 TDI quattro	ch.8D-X-200001→; Number of Ribs: 7; Type: ATJ	<b>F8-6391</b>		



**Article Description****Article Nr.****Fitting Position**

<b>A4 Avant (8D5, B5)</b>			<b>11/1994 → 09/2001</b>		
Engine Mounting	2.5 TDI, 2.5 TDI quattro		<b>F8-6530</b>		
Rubber Buffer, engine mounting	2.5 TDI, 2.5 TDI quattro	ch.→8D1200000	<b>F8-6758</b>		
Rubber Buffer, engine mounting	RS4 quattro		<b>F8-6758</b>		
Repair Kit, suspension strut	1.6, 1.8, 1.8 quattro, 1.8 T, 1.8 T quattro, 1.9 DUO, 1.9 TDI, 1.9 TDI quattro, 2.4, 2.4 quattro, 2.5 TDI, 2.5 TDI quattro, 2.6, 2.6 quattro, 2.8, 2.8 quattro, S4 quattro	ch.→8D-W-012334	<b>F8-7096</b>		
Repair Kit, suspension strut	1.6, 1.8, 1.8 quattro, 1.8 T, 1.8 T quattro, 1.9 DUO, 1.9 TDI, 1.9 TDI quattro, 2.4, 2.4 quattro, 2.5 TDI, 2.5 TDI quattro, 2.6, 2.6 quattro, 2.8, 2.8 quattro	ch.8D-W-012335→; ch.→8E-1-000001	<b>F8-7097</b>		
Repair Kit, suspension strut	RS4 quattro, S4 quattro	ch.8D-W-012335→; ch.→8D-1-200000	<b>F8-7097</b>		
Top Strut Mounting	1.6, 1.8, 1.8 T, 1.9 DUO, 1.9 TDI, 2.4, 2.5 TDI, 2.6, 2.8	for OE: 8D0512333	<b>F8-7100</b>		
Top Strut Mounting	1.6, 1.8, 1.8 T, 1.9 DUO, 1.9 TDI, 2.4, 2.5 TDI, 2.6, 2.8	for OE: 8D0512335	<b>F8-7101</b>		
Bellow, steering	1.8 T, 1.8 T quattro, 2.4, 2.4 quattro, 2.5 TDI, 2.5 TDI quattro, 2.6, 2.6 quattro, 2.8, 2.8 quattro, S4 quattro	for vehicles with steering damper	<b>F8-7148</b>		H=141; d1=65; d2=65
Control Arm-/Trailing Arm Bush	1.8 quattro, 1.8 T quattro, 1.9 TDI quattro, 2.4 quattro, 2.5 TDI quattro, 2.6 quattro, 2.8 quattro, RS4 quattro, S4 quattro	for OE: 8A0505323A, 8A0505323B, 8A0505324B, 8D0505323A, 8D0505323B, 8D0505324B	<b>F8-7149</b>		
Rubber Buffer, suspension	1.6, 1.8, 1.8 T, 1.9 DUO, 1.9 TDI, 2.4, 2.5 TDI, 2.6, 2.8	ch.8D-X-200 000→; <b>ST</b>	<b>F8-7598</b>		H=134
Protective Cap/Bellow, shock absorber	All Models		<b>F8-7687</b>		H=80
Rubber Buffer, suspension	1.6, 1.8, 1.8 T, 1.9 DUO, 1.9 TDI, 2.4, 2.5 TDI, 2.6, 2.8	ch.→8D-X-199 999; <b>ST</b>	<b>F8-7693</b>		H=127
Control Arm-/Trailing Arm Bush	1.6, 1.8, 1.8 quattro, 1.8 T, 1.8 T quattro, 1.9 TDI, 1.9 TDI quattro, 2.4, 2.4 quattro, 2.5 TDI, 2.5 TDI quattro, 2.6, 2.6 quattro, 2.8, 2.8 quattro	ch.8D-X-200001→; for OE: 1BV; <b>SP</b>	<b>F8-7796</b>		H=40; d=10; D=46,5
Control Arm-/Trailing Arm Bush	1.9 TDI, 1.9 TDI quattro, 2.8, 2.8 quattro	for OE: 1BV; <b>SP</b>	<b>F8-7796</b>		H=40; d=10; D=46,5
Control Arm-/Trailing Arm Bush	RS4 quattro, S4 quattro		<b>F8-7796</b>		H=40; d=10; D=46,5
Stabiliser Mounting	RS4 quattro		<b>F8-7922</b>		d=29
Control Arm-/Trailing Arm Bush	1.8 quattro, 1.8 T quattro, 1.9 TDI quattro, 2.4 quattro, 2.5 TDI quattro, 2.6 quattro, 2.8 quattro, RS4 quattro, S4 quattro		<b>F8-7924</b>		
Mounting, manual transmission	2.4, 2.5 TDI, 2.5 TDI quattro, 2.8	5-speed	<b>F8-7971</b>		
Mounting, manual transmission	2.4, 2.8	ch.8D-X-200001→;	<b>F8-7971</b>		
Mounting, manual transmission	2.5 TDI	Transmission Nr: DQS, DSE, FRF;	<b>F8-7971</b>		
Mounting, manual transmission	2.5 TDI quattro	Transmission Nr: DQT;  6-speed	<b>F8-7971</b>		
Mounting, manual transmission	2.8		<b>F8-7971</b>		
Mounting, automatic transmission	1.6	ch.8D-X-200 001→;  ANA;  4-speed	<b>F8-8012</b>		H=66; D=71



Article Description

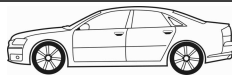

Article Nr.

Fitting Position



**A4 Avant (8D5, B5)**

11/1994 → 09/2001

Mounting, automatic transmission	1.8	ch.8D-X-200 001→; 5-speed	<b>F8-8012</b>		H=66; D=71
Mounting, automatic transmission	1.8 T	ch.8D-X-200 001→; AEB, APU; 5-speed	<b>F8-8012</b>		H=66; D=71
Mounting, automatic transmission	1.9 TDI	AFN	<b>F8-8012</b>		H=66; D=71
Mounting, automatic transmission	1.8 T, 2.4, 2.4 quattro, 2.5 TDI, 2.5 TDI quattro, 2.6, 2.8, 2.8 quattro		<b>F8-8179</b>		
Suspension Kit	1.6, 1.8, 1.8 quattro, 1.8 T, 1.8 T quattro, 1.9 TDI, 1.9 TDI quattro, 2.4, 2.4 quattro, 2.5 TDI, 2.5 TDI quattro, 2.6, 2.6 quattro, 2.8, 2.8 quattro, RS4 quattro, S4 quattro	ch.8D-V-152088→	<b>G8-529</b>		
Suspension Kit	1.8, 1.8 quattro	ch.8D-V-152088→; 01/1996 →	<b>G8-529</b>		
Control Arm-/Trailing Arm Bush	1.6	03/1996 →	<b>G9-615</b>		H1=66; H2=80; d=12; D=65
Control Arm-/Trailing Arm Bush	1.8, 1.8 quattro, 1.8 T, 1.8 T quattro, 1.9 TDI, 1.9 TDI quattro, 2.4, 2.4 quattro, 2.5 TDI, 2.5 TDI quattro, 2.6, 2.6 quattro, 2.8, 2.8 quattro, S4 quattro		<b>G9-615</b>		H1=66; H2=80; d=12; D=65
Control Arm-/Trailing Arm Bush	1.6	03/1996 →	<b>G9-616</b>		H1=26; H2=40; d=10; D1=24; D2=46
Control Arm-/Trailing Arm Bush	1.6, 1.8, 1.8 quattro, 1.8 T, 1.8 T quattro, 1.9 DUO, 1.9 TDI, 1.9 TDI quattro, 2.4, 2.4 quattro, 2.5 TDI, 2.5 TDI quattro, 2.6, 2.6 quattro, 2.8, 2.8 quattro, RS4 quattro, S4 quattro		<b>G9-616</b>		H1=26; H2=40; d=10; D1=24; D2=46
Control Arm-/Trailing Arm Bush	2.8, 2.8 quattro	for OE: 8D0407505B	<b>G9-616</b>		H1=26; H2=40; d=10; D1=24; D2=46
Bellow, steering	1.6, 1.8, 1.8 quattro, 1.8 T, 1.8 T quattro, 1.9 DUO, 1.9 TDI, 1.9 TDI quattro, 2.4	ch.→8D-X-053000; with clamps;	<b>LM-10005S</b>		d1=18; d2=54; L [mm]=200
Bellow, steering	1.6, 1.8, 1.8 quattro, 1.8 T, 1.8 T quattro, 1.9 DUO, 1.9 TDI, 1.9 TDI quattro, 2.4	ch.→8D-X-053000; with clamps;	<b>LM-10005S</b>		d1=18; d2=54; L [mm]=200
Bellow, steering	1.6, 1.8, 1.8 quattro, 1.8 T, 1.8 T quattro, 1.9 DUO, 1.9 TDI, 1.9 TDI quattro, 2.6	ch.→8D-X-053000; with clamps;	<b>LM-10005S</b>		d1=18; d2=54; L [mm]=200
Bellow, steering	1.6, 1.8, 1.8 quattro, 1.8 T, 1.8 T quattro, 1.9 DUO, 1.9 TDI, 1.9 TDI quattro, 2.6	ch.→8D-X-053000; with clamps;	<b>LM-10005S</b>		d1=18; d2=54; L [mm]=200
Bellow, steering	2.4, 2.4 quattro, 2.5 TDI, 2.5 TDI quattro, 2.6, 2.6 quattro, 2.8, 2.8 quattro, S4 quattro	ch.→8D-X-053000; with clamps;	<b>LM-10005S</b>		d1=18; d2=54; L [mm]=200
Bellow, steering	2.8, 2.8 quattro	with clamps;	<b>LM-10005S</b>		d1=18; d2=54; L [mm]=200
Bellow, steering	1.6, 1.8, 1.8 quattro, 1.8 T, 1.8 T quattro, 1.9 DUO, 1.9 TDI, 1.9 TDI quattro	ch.8D-X-053001→; with clamps;	<b>LM-10021S</b>		d1=20; d2=63; L [mm]=254
Bellow, steering	1.6, 1.8, 1.8 quattro, 1.8 T, 1.8 T quattro, 1.9 DUO, 1.9 TDI, 1.9 TDI quattro	ch.8D-X-053001→; with clamps;	<b>LM-10021S</b>		d1=20; d2=63; L [mm]=254
Bellow, steering	1.6, 1.9 TDI, 1.9 TDI quattro, RS4 quattro	with clamps;	<b>LM-10021S</b>		d1=20; d2=63; L [mm]=254
Bellow, steering	1.6, 1.9 TDI, 1.9 TDI quattro, RS4 quattro	with clamps;	<b>LM-10021S</b>		d1=20; d2=63; L [mm]=254
Bellow, steering	2.4, 2.4 quattro, 2.5 TDI, 2.5 TDI quattro, 2.6, 2.6 quattro, 2.8, 2.8 quattro, S4 quattro	ch.8D-X-303810→; with clamps;	<b>LM-10021S</b>		d1=20; d2=63; L [mm]=254

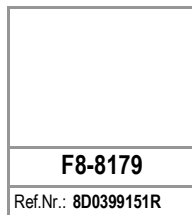

**Article Description****Article Nr.****Fitting Position**

<b>A4 Avant (8D5, B5)</b>				<b>11/1994 → 09/2001</b>	
Bellow, steering	2.4, 2.4 quattro, 2.5 TDI, 2.5 TDI quattro, 2.6, 2.6 quattro, 2.8, 2.8 quattro, S4 quattro	ch.8D-Y-005049→;  with clamps;	<b>LM-10021S</b>		d1=20; d2=63; L [mm]=254
<b>A4 (8E2, B6)</b>				<b>11/2000 → 12/2004</b>	
Dust Cover Kit, shock absorber	1.6, 1.8 T, 1.8 T quattro, 1.9 TDI, 1.9 TDI quattro, 2.0, 2.0 FSI, 2.4, 2.5 TDI, 2.5 TDI quattro, 3.0, 3.0 quattro	not for equipment variant: 1BA	<b>AK-735101</b>		
Alternator Freewheel Clutch	1.9 TDI, 1.9 TDI quattro		<b>F5-1004</b>		
Alternator Freewheel Clutch	1.9 TDI, 1.9 TDI quattro		<b>F5-1006</b>		
Alternator Freewheel Clutch	1.6, 1.8 T, 1.8 T quattro, 2.0, 2.0 FSI		<b>F5-1044</b>		
Control Arm-/Trailing Arm Bush	All Models		<b>F8-4045</b>		H1=31; H2=60; d=12; D=50
Mounting, radiator	1.6, 1.8 T, 1.8 T quattro, 1.9 TDI, 1.9 TDI quattro, 2.0, 2.0 FSI, 2.4, 2.5 TDI, 2.5 TDI quattro, 3.0, 3.0 quattro, S4 quattro		<b>F8-5526</b>		d=15; D=40; Thick. [mm]=25
Control Arm-/Trailing Arm Bush	1.6, 1.8 T, 1.8 T quattro, 1.9 TDI, 1.9 TDI quattro, 2.0, 2.0 FSI, 2.4, 2.5 TDI, 2.5 TDI quattro, 3.0, 3.0 quattro, S4 quattro	not for PR: 1BV	<b>F8-5542</b>		H=40; d=10; D=46
Control Arm-/Trailing Arm Bush	1.8 T	BFB; not for PR: 1BV	<b>F8-5542</b>		H=40; d=10; D=46
Engine Mounting	2.4		<b>F8-5567</b>		
Mounting, automatic transmission	1.9 TDI		<b>F8-5574</b>		
Mounting, automatic transmission	1.9 TDI	ch.4B-1-039836→;  4-speed	<b>F8-5574</b>		
Mounting, automatic transmission	1.9 TDI	AVF; Transmission Type: CVT (Stepless)	<b>F8-5574</b>		
Mounting, automatic transmission	1.9 TDI, 1.9 TDI quattro	Transmission Type: CVT (Stepless)	<b>F8-5574</b>		
Mounting, automatic transmission	1.6, 1.9 TDI		<b>F8-5575</b>		H=72; D=71
Mounting, automatic transmission	1.8 T	ch.8E-4-000000→; Transmission Type: CVT (Stepless)	<b>F8-5575</b>		H=72; D=71
Mounting, automatic transmission	1.8 T, 2.0, 2.0 FSI, 2.5 TDI, 3.0	Transmission Type: CVT (Stepless)	<b>F8-5575</b>		H=72; D=71
Mounting, automatic transmission	1.9 TDI, 2.4, 3.0	ch.→8E-3-500000; Transmission Type: CVT (Stepless)	<b>F8-5575</b>		H=72; D=71
Mounting, automatic transmission	2.4		<b>F8-5575</b>		H=72; D=71
Belt Pulley, crankshaft	1.8 T, 1.8 T quattro, 2.0, 2.0 FSI		<b>F8-5650</b>		
Rubber Buffer, suspension	1.6, 1.8 T, 1.8 T quattro, 1.9 TDI, 1.9 TDI quattro, 2.0, 2.0 FSI, 2.4, 2.5 TDI, 2.5 TDI quattro, 3.0, 3.0 quattro		<b>F8-5994</b>		H=85
Rubber Buffer, suspension	1.6, 1.8 T, 1.8 T quattro, 1.9 TDI, 2.0, 2.5 TDI quattro, 3.0, 3.0 quattro		<b>F8-6001</b>		H=134
Rubber Buffer, suspension	1.6, 1.8 T, 1.8 T quattro, 1.9 TDI, 1.9 TDI quattro, 2.0, 2.5 TDI quattro, 3.0, 3.0 quattro		<b>F8-6003</b>		H=103.5



Article Description			Article Nr.	Fitting Position	
---------------------	--	--	-------------	------------------	--

A4 (8E2, B6)			11/2000 → 12/2004		
Rubber Buffer, suspension	1.6, 1.8 T, 1.8 T quattro, 1.9 TDI, 1.9 TDI quattro, 2.0, 2.5 TDI quattro, 3.0, 3.0 quattro	△	F8-6005		H=134
Control Arm-/Trailing Arm Bush	All Models		F8-6151		d=12; D=40; W=37
Top Strut Mounting	All Models		F8-6352		
Belt Pulley, crankshaft	1.9 TDI, 1.9 TDI quattro	ch.→8E-3-410000; Number of Ribs: 7	F8-6391		
Belt Pulley, crankshaft	1.9 TDI	ch.8E-3-410001→; ch.→8E-5-400000; Number of Ribs: 5; Parameter: 6PK	F8-6396		H=41.6; d=30; Mounting points diam.[mm]=7, 8.6; D=139.7
Belt Pulley, crankshaft	1.9 TDI, 1.9 TDI quattro	ch.8E-3-410001→; Number of Ribs: 5; Parameter: 6PK	F8-6396		H=41.6; d=30; Mounting points diam.[mm]=7, 8.6; D=139.7
Mounting, automatic transmission	1.8 T quattro, 1.9 TDI quattro, 2.5 TDI quattro	ch.8E-4-293001→	F8-6737		
Mounting, automatic transmission	3.0 quattro	ch.8E-4-293001→;  5-speed	F8-6737		
Mounting, automatic transmission	S4 quattro	ch.8E-4-293001→;  6-speed	F8-6737		
Mounting, automatic transmission	3.0 quattro	ch.8E-4-293001→;	F8-6738		
Mounting, automatic transmission	S4 quattro	ch.8E-4-293001→;	F8-6738		
Engine Mounting	2.4	ch.→8E-5-400000	F8-6892		
Engine Mounting	2.4	ch.→8E-5-400000;	F8-6892		
Engine Mounting	3.0	ch.8E-1-000001→; ch.→8E-5-400000	F8-6892		
Engine Mounting	3.0 quattro	ch.8E-1-000001→; ch.→8E-5-400000;	F8-6892		
Engine Mounting	2.4	ch.8E-5-400001→;	F8-6961		
Engine Mounting	2.4, 3.0, 3.0 quattro	ch.8E-5-400001→	F8-6961		
Engine Mounting	3.0 quattro	ch.8E-5-400001→;	F8-6961		
Top Strut Mounting	All Models		F8-7451		
Rubber Buffer, suspension	1.9 TDI, 1.9 TDI quattro, 2.0 FSI, 2.4, 2.5 TDI, 2.5 TDI quattro, 3.0, 3.0 quattro	for OE: 1BA; ☆	F8-7577		H=94
Rubber Buffer, suspension	S4 quattro		F8-7577		H=94
Rubber Buffer, engine mounting	1.6, 1.8 T, 1.8 T quattro, 1.9 TDI, 1.9 TDI quattro, 2.0, 2.0 FSI, 3.0, 3.0 quattro	ch.→8E-5-400000	F8-7599		
Rubber Buffer, engine mounting	1.8 T, 1.8 T quattro, 2.4, 2.5 TDI, 2.5 TDI quattro, 3.0, 3.0 quattro, S4 quattro		F8-7599		
Rubber Buffer, engine mounting	2.5 TDI	ch.→8E-5-400000;	F8-7599		
Protective Cap/Bellow, shock absorber	All Models		F8-7682		H=160
Protective Cap/Bellow, shock absorber	All Models		F8-7687		H=80

<b>F8-6005</b>	<b>F8-6151</b>	<b>F8-6352</b>	<b>F8-6391</b>	<b>F8-6396</b>	<b>F8-6737</b>	<b>F8-6738</b>
Ref.Nr.: 4B0512131N	Ref.Nr.: 8E0407181B	Ref.Nr.: 4F0513353B	Ref.Nr.: 038105243F	Ref.Nr.: 03G105243	Ref.Nr.: 8E0599125J	Ref.Nr.: 8E0599125K
<b>F8-6892</b>	<b>F8-6961</b>	<b>F8-7451</b>	<b>F8-7577</b>	<b>F8-7599</b>	<b>F8-7682</b>	<b>F8-7687</b>
Ref.Nr.: 8E0199379F	Ref.Nr.: 8E0199379AF	Ref.Nr.: 8E0412377C	Ref.Nr.: 8D0 412 131 H	Ref.Nr.: 8E0 199 339	Ref.Nr.: 8E0512137E	Ref.Nr.: 4D0412137B
<b>F8-7796</b>						
Ref.Nr.: 8D0407515C						

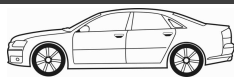

**Article Description****Article Nr.****Fitting Position**

<b>A4 (8E2, B6)</b>		<b>11/2000 → 12/2004</b>		
Control Arm-/Trailing Arm Bush	1.6, 1.8 T, 1.8 T quattro, 1.9 TDI, 1.9 TDI quattro, 2.0, 2.0 FSI, 2.4, 2.5 TDI, 2.5 TDI quattro, 3.0, 3.0 quattro	for OE: 1BV;	<b>F8-7796</b>	H=40; d=10; D=46,5
Control Arm-/Trailing Arm Bush	S4 quattro		<b>F8-7796</b>	H=40; d=10; D=46,5
Protective Cap/Bellow, shock absorber	1.6, 1.8 T, 1.8 T quattro, 1.9 TDI, 1.9 TDI quattro, 2.0, 2.0 FSI, 2.4, 2.5 TDI, 2.5 TDI quattro, 3.0, 3.0 quattro	for OE: 1BR;	<b>F8-7802</b>	H=156
Stabiliser Mounting	All Models		<b>F8-7922</b>	d=29
Engine Mounting	1.9 TDI, 1.9 TDI quattro		<b>F8-7969</b>	
Mounting, manual transmission	3.0	ch.→8E-2-350000;	<b>F8-7971</b>	
Stabiliser Mounting	1.6, 1.8 T, 1.8 T quattro, 1.9 TDI, 1.9 TDI quattro, 2.0, 2.0 FSI, 2.4, 2.5 TDI, 2.5 TDI quattro, 3.0, 3.0 quattro, S4 quattro		<b>F8-7979</b>	
Mounting, automatic transmission	1.8 T	ch.→8E-3-500 000;  BFB;	<b>F8-8012</b>	H=66; D=71
Mounting, automatic transmission	2.4	ch.→8E-3-500 000;	<b>F8-8012</b>	H=66; D=71
Control Arm-/Trailing Arm Bush	1.6, 1.8 T, 1.8 T quattro, 1.9 TDI, 1.9 TDI quattro, 2.0, 2.0 FSI, 2.4, 2.5 TDI, 2.5 TDI quattro, 3.0, 3.0 quattro, S4 quattro		<b>F8-8133</b>	H=60; d=12; D=46
Engine Mounting	1.6, 1.8 T, 1.8 T quattro, 1.9 TDI, 2.0, 2.0 FSI		<b>F8-8143</b>	
Mounting, automatic transmission	3.0 quattro		<b>F8-8179</b>	
Control Arm-/Trailing Arm Bush	1.8 T, 1.8 T quattro, 1.9 TDI, 2.0, 2.5 TDI quattro, 3.0, 3.0 quattro		<b>G9-616</b>	H1=26; H2=40; d=10; D1=24; D2=46
Bellow Set, drive shaft	1.8 T	not for transmission type: ENN, FPS, FTW; with clamps	<b>MK-810160</b>	L=116
Bellow Set, drive shaft	1.8 T, 1.8 T quattro, 1.9 TDI, 1.9 TDI quattro, 2.0 FSI, 2.5 TDI	with clamps	<b>MK-810160</b>	L=116
Bellow Set, drive shaft	2.0	with clamps; Transmission Type: FJP	<b>MK-810160</b>	L=116
Bellow Set, drive shaft	2.4	ch.→8E-3-390000; with clamps	<b>MK-810160</b>	L=116
Bellow Set, drive shaft	2.5 TDI quattro	AKE; with clamps	<b>MK-810160</b>	L=116
Bellow Set, drive shaft	3.0	AVK; with clamps	<b>MK-810160</b>	L=116
Bellow Set, drive shaft	3.0 quattro	with clamps;	<b>MK-810160</b>	L=116
<b>A4 Avant (8E5, B6)</b>		<b>10/2000 → 12/2004</b>		
Dust Cover Kit, shock absorber	1.6, 1.8 T, 1.8 T quattro, 1.9 TDI, 1.9 TDI quattro, 2.0, 2.0 FSI, 2.4, 2.5 TDI, 2.5 TDI quattro, 3.0, 3.0 quattro	not for equipment variant: 1BA	<b>AK-735101</b>	
Alternator Freewheel Clutch	1.9 TDI, 1.9 TDI quattro		<b>F5-1004</b>	
Alternator Freewheel Clutch	1.9 TDI, 1.9 TDI quattro		<b>F5-1006</b>	
Alternator Freewheel Clutch	1.6, 1.8 T, 1.8 T quattro, 2.0, 2.0 FSI		<b>F5-1044</b>	
Control Arm-/Trailing Arm Bush	All Models		<b>F8-4045</b>	H1=31; H2=60; d=12; D=50

<b>AK-735101</b>	<b>F5-1004</b>	<b>F5-1006</b>	<b>F5-1044</b>	<b>F8-4045</b>	<b>F8-5526</b>	<b>F8-7796</b>
Ref.Nr.: 4D0412137C	Ref.Nr.: 038903119T	Ref.Nr.: 038903119M	Ref.Nr.: 06B903119B	Ref.Nr.: 4D0407182E	Ref.Nr.: 8D0121275	Ref.Nr.: 8D0407515C
<b>F8-7802</b>	<b>F8-7922</b>	<b>F8-7969</b>	<b>F8-7971</b>	<b>F8-7979</b>	<b>F8-8012</b>	<b>F8-8133</b>
Ref.Nr.: 4B0512137B	Ref.Nr.: 4D0411327J	Ref.Nr.: 8E0199382K	Ref.Nr.: 4B0399151M	Ref.Nr.: 4B0511327	Ref.Nr.: 8D0399415E	Ref.Nr.: 8E0505203D
<b>F8-8143</b>	<b>F8-8179</b>	<b>G9-616</b>	<b>MK-810160</b>			
Ref.Nr.: 8E0399105HB	Ref.Nr.: 8D0399151R	Ref.Nr.: 4D0407515	Ref.Nr.: 3D0 498 201			

Article Description



Article Nr.

Fitting Position



## A4 Avant (8E5, B6)

10/2000 → 12/2004

Mounting, radiator	All Models		<b>F8-5526</b>		d=15; D=40; Thick. [mm]=25
Control Arm-/Trailing Arm Bush	1.6, 1.8 T, 1.8 T quattro, 1.9 TDI, 1.9 TDI quattro, 2.0, 2.0 FSI, 2.4, 2.5 TDI, 2.5 TDI quattro, 3.0, 3.0 quattro, S4 quattro	not for PR: 1BV	<b>F8-5542</b>		H=40; d=10; D=46
Control Arm-/Trailing Arm Bush	1.9 TDI	AVF; not for PR: 1BV	<b>F8-5542</b>		H=40; d=10; D=46
Engine Mounting	2.4		<b>F8-5567</b>		
Mounting, automatic transmission	1.9 TDI	ch.3B-X-700001→	<b>F8-5574</b>		
Mounting, automatic transmission	1.9 TDI	Transmission Type: CVT (Stepless)	<b>F8-5574</b>		
Mounting, automatic transmission	1.9 TDI, 1.9 TDI quattro		<b>F8-5574</b>		
Mounting, automatic transmission	1.6, 1.9 TDI		<b>F8-5575</b>		H=72; D=71
Mounting, automatic transmission	1.8 T, 2.0 FSI, 2.5 TDI, 3.0	Transmission Type: CVT (Stepless)	<b>F8-5575</b>		H=72; D=71
Mounting, automatic transmission	1.9 TDI	ch.→8E-3-500000	<b>F8-5575</b>		H=72; D=71
Mounting, automatic transmission	2.0	ch.8D-X-200001→; ch.→8D-W-080000; Transmission Type: CVT (Stepless)	<b>F8-5575</b>		H=72; D=71
Mounting, automatic transmission	2.4		<b>F8-5575</b>		H=72; D=71
Mounting, automatic transmission	2.4, 3.0	ch.→8E-3-500000; Transmission Type: CVT (Stepless)	<b>F8-5575</b>		H=72; D=71
Belt Pulley, crankshaft	1.8 T, 1.8 T quattro, 2.0 FSI		<b>F8-5650</b>		
Rubber Buffer, suspension	1.6, 1.8 T, 1.8 T quattro, 1.9 TDI, 1.9 TDI quattro, 2.0, 2.0 FSI, 2.4, 2.5 TDI, 2.5 TDI quattro, 3.0, 3.0 quattro		<b>F8-5994</b>		H=85
Rubber Buffer, suspension	1.6, 1.8 T, 1.9 TDI, 2.0, 3.0		<b>F8-6001</b>		H=134
Rubber Buffer, suspension	1.6, 1.8 T, 1.9 TDI, 2.0, 3.0		<b>F8-6003</b>		H=103.5
Rubber Buffer, suspension	1.6, 1.8 T, 1.8 T quattro, 1.9 TDI, 1.9 TDI quattro, 2.0, 3.0, 3.0 quattro		<b>F8-6005</b>		H=134
Control Arm-/Trailing Arm Bush	1.6, 1.8 T, 1.8 T quattro, 1.9 TDI, 1.9 TDI quattro, 2.0, 2.0 FSI, 2.4, 2.5 TDI, 2.5 TDI quattro, 3.0, 3.0 quattro, S4 quattro		<b>F8-6151</b>		d=12; D=40; W=37
Top Strut Mounting	All Models		<b>F8-6352</b>		
Belt Pulley, crankshaft	1.9 TDI, 1.9 TDI quattro	ch.→8E-3-410000; Number of Ribs: 7	<b>F8-6391</b>		
Belt Pulley, crankshaft	1.9 TDI	ch.8E-3-410001→; ch.→8E-5-400000; Number of Ribs: 5; Parameter: 6PK	<b>F8-6396</b>		H=41.6; d=30; Mounting points diam.[mm]=7, 8.6; D=139.7
Belt Pulley, crankshaft	1.9 TDI, 1.9 TDI quattro	ch.8E-3-410001→; Number of Ribs: 5; Parameter: 6PK	<b>F8-6396</b>		H=41.6; d=30; Mounting points diam.[mm]=7, 8.6; D=139.7
Mounting, automatic transmission	1.8 T quattro, 1.9 TDI quattro, 2.5 TDI quattro, 3.0 quattro	ch.8E-4-293001→	<b>F8-6737</b>		

<b>F8-5526</b>	<b>F8-5542</b>	<b>F8-5567</b>	<b>F8-5574</b>	<b>F8-5575</b>	<b>F8-5650</b>	<b>F8-5994</b>
Ref.Nr.: 8D0121275	Ref.Nr.: 4B0407515	Ref.Nr.: 8D0199379K	Ref.Nr.: 8D0399419G	Ref.Nr.: 8D0399415D	Ref.Nr.: 06A105243E	Ref.Nr.: 8D0412131F
<b>F8-6001</b>	<b>F8-6003</b>	<b>F8-6005</b>	<b>F8-6151</b>	<b>F8-6352</b>	<b>F8-6391</b>	<b>F8-6396</b>
Ref.Nr.: 3B0512131H	Ref.Nr.: 4B0512131B	Ref.Nr.: 4B0512131N	Ref.Nr.: 8E0407181B	Ref.Nr.: 4F0513353B	Ref.Nr.: 038105243F	Ref.Nr.: 03G105243
<b>F8-6737</b>						
Ref.Nr.: 8E0599125J						

**Article Description****Article Nr.****Fitting Position**

<b>A4 Avant (8E5, B6)</b>				<b>10/2000 → 12/2004</b>	
Mounting, automatic transmission	S4 quattro	ch.8E-4-293001 →;  6-speed	<b>F8-6737</b>		
Engine Mounting	2.4	ch.→8E-5-400000;	<b>F8-6892</b>		
Engine Mounting	2.4, 3.0	ch.→8E-5-400000	<b>F8-6892</b>		
Engine Mounting	3.0 quattro	ch.→8E-5-400000;  AVN	<b>F8-6892</b>		
Engine Mounting	2.4	ch.8E-5-400001 →;	<b>F8-6961</b>		
Engine Mounting	2.4, 3.0, 3.0 quattro	ch.8E-5-400001 →	<b>F8-6961</b>		
Engine Mounting	3.0 quattro	ch.8E-5-400001 →;  AVN	<b>F8-6961</b>		
Top Strut Mounting	All Models		<b>F8-7451</b>		
Rubber Buffer, suspension	1.9 TDI, 1.9 TDI quattro, 2.0 FSI, 2.4, 2.5 TDI, 2.5 TDI quattro, 3.0, 3.0 quattro	for OE: 1BA;	<b>F8-7577</b>		H=94
Rubber Buffer, suspension	S4 quattro		<b>F8-7577</b>		H=94
Rubber Buffer, engine mounting	1.6, 1.8 T, 1.8 T quattro, 1.9 TDI, 1.9 TDI quattro, 2.0, 2.0 FSI, 3.0, 3.0 quattro	ch.→8E-5-400000	<b>F8-7599</b>		
Rubber Buffer, engine mounting	1.8 T, 1.8 T quattro, 2.4, 2.5 TDI, 2.5 TDI quattro, 3.0, 3.0 quattro, S4 quattro		<b>F8-7599</b>		
Rubber Buffer, engine mounting	1.9 TDI	ch.→8E-5-400000;  AVF	<b>F8-7599</b>		
Rubber Buffer, engine mounting	2.5 TDI	ch.→8E-5-400000;  BCZ, BDG	<b>F8-7599</b>		
Protective Cap/Bellow, shock absorber	All Models		<b>F8-7682</b>		H=160
Protective Cap/Bellow, shock absorber	1.6, 1.8 T, 1.8 T quattro, 1.9 TDI, 1.9 TDI quattro, 2.0, 2.0 FSI, 2.4, 2.5 TDI, 2.5 TDI quattro, 3.0, 3.0 quattro, S4 quattro		<b>F8-7687</b>		H=80
Control Arm-/Trailing Arm Bush	1.6, 1.8 T, 1.8 T quattro, 1.9 TDI, 1.9 TDI quattro, 2.0, 2.0 FSI, 2.4, 2.5 TDI, 2.5 TDI quattro, 3.0, 3.0 quattro	S Line; for OE: 1BV;	<b>F8-7796</b>		H=40; d=10; D=46,5
Control Arm-/Trailing Arm Bush	S4 quattro		<b>F8-7796</b>		H=40; d=10; D=46,5
Protective Cap/Bellow, shock absorber	1.6, 1.8 T, 1.8 T quattro, 1.9 TDI, 1.9 TDI quattro, 2.0, 2.0 FSI, 2.4, 2.5 TDI, 2.5 TDI quattro, 3.0, 3.0 quattro	for OE: 1BR;	<b>F8-7802</b>		H=156
Stabiliser Mounting	1.6, 1.8 T, 1.8 T quattro, 1.9 TDI, 1.9 TDI quattro, 2.0, 2.0 FSI, 2.4, 2.5 TDI, 2.5 TDI quattro, 3.0, 3.0 quattro, S4 quattro		<b>F8-7922</b>		d=29
Engine Mounting	1.9 TDI, 1.9 TDI quattro		<b>F8-7969</b>		
Mounting, manual transmission	2.5 TDi, 3.0	ch.→8E-2-350000;  5-speed	<b>F8-7971</b>		
Stabiliser Mounting	1.6, 1.8 T, 1.8 T quattro, 1.9 TDI, 1.9 TDI quattro, 2.0, 2.0 FSI, 2.4, 2.5 TDI, 2.5 TDI quattro, 3.0, 3.0 quattro, S4 quattro		<b>F8-7979</b>		
Mounting, automatic transmission	1.8 T	ch.→8E-3-500 000;  5-speed	<b>F8-8012</b>		H=66; D=71
Mounting, automatic transmission	2.4	ch.→8E-3-500 001;  5-speed	<b>F8-8012</b>		H=66; D=71

<b>F8-6737</b>	<b>F8-6892</b>	<b>F8-6961</b>	<b>F8-7451</b>	<b>F8-7577</b>	<b>F8-7599</b>	<b>F8-7682</b>
Ref.Nr.: 8E0599125J	Ref.Nr.: 8E0199379F	Ref.Nr.: 8E0199379AF	Ref.Nr.: 8E0412377C	Ref.Nr.: 8D0 412 131 H	Ref.Nr.: 8E0 199 339	Ref.Nr.: 8E0512137E
<b>F8-7687</b>	<b>F8-7796</b>	<b>F8-7802</b>	<b>F8-7922</b>	<b>F8-7969</b>	<b>F8-7971</b>	<b>F8-7979</b>
Ref.Nr.: 4D0412137B	Ref.Nr.: 8D0407515C	Ref.Nr.: 4B0512137B	Ref.Nr.: 4D0411327J	Ref.Nr.: 8E0199382K	Ref.Nr.: 4B0399151M	Ref.Nr.: 4B0511327
<b>F8-8012</b>	<b>F8-8133</b>					
Ref.Nr.: 8D0399415E	Ref.Nr.: 8E0505203D					

<b>Article Description</b>			<b>Article Nr.</b>	<b>Fitting Position</b>	
----------------------------	--	--	--------------------	-------------------------	--

<b>A4 Avant (8E5, B6)</b>			<b>10/2000 → 12/2004</b>		
Control Arm-/Trailing Arm Bush	1.6, 1.8 T, 1.8 T quattro, 1.9 TDI, 1.9 TDI quattro, 2.0, 2.0 FSI, 2.4, 2.5 TDI, 2.5 TDI quattro, 3.0, 3.0 quattro, S4 quattro		<b>F8-8133</b>		H=60; d=12; D=46
Engine Mounting	1.6, 1.8 T, 1.8 T quattro, 1.9 TDI, 2.0, 2.0 FSI		<b>F8-8143</b>		
Mounting, automatic transmission	3.0 quattro		<b>F8-8179</b>		
Bellow Set, drive shaft	1.8 T	not for transmission type: ENN, FPS, FTW; with clamps	<b>MK-810160</b>		L=116
Bellow Set, drive shaft	1.8 T, 1.8 T quattro, 1.9 TDI, 1.9 TDI quattro, 2.0 FSI, 2.5 TDI	with clamps	<b>MK-810160</b>		L=116
Bellow Set, drive shaft	2.0	with clamps; Transmission Type: FJP	<b>MK-810160</b>		L=116
Bellow Set, drive shaft	2.4	ch.→8E-3-390000; with clamps	<b>MK-810160</b>		L=116
Bellow Set, drive shaft	2.5 TDI quattro	AKE; with clamps	<b>MK-810160</b>		L=116
Bellow Set, drive shaft	3.0 quattro	with clamps;	<b>MK-810160</b>		L=116
<b>A4 (8EC, B7)</b>			<b>11/2004 → 06/2008</b>		
Dust Cover Kit, shock absorber	1.6, 1.8 T, 1.8 T quattro, 1.9 TDI, 2.0, 2.0 TDI, 2.0 TDI 16V, 2.0 TFSI, 2.0 TFSI quattro, 2.5 TDI, 3.0 TDI quattro, 3.2 FSI, 3.2 FSI quattro	not for equipment variant: 1BA	<b>AK-735101</b>		
Alternator Freewheel Clutch	1.9 TDI, 2.0 TDI, 2.0 TDI 16V, 2.0 TDI quattro		<b>F5-1004</b>		
Alternator Freewheel Clutch	1.9 TDI		<b>F5-1006</b>		
Alternator Freewheel Clutch	1.6, 1.8 T, 1.8 T quattro, 2.0, 2.0 TFSI, 2.0 TFSI quattro		<b>F5-1044</b>		
Control Arm-/Trailing Arm Bush	All Models		<b>F8-4045</b>		H1=31; H2=60; d=12; D=50
Mounting, automatic transmission	1.9 TDI		<b>F8-5575</b>		H=72; D=71
Belt Pulley, crankshaft	1.8 T, 2.0		<b>F8-5650</b>		
Rubber Buffer, suspension	1.6, 1.8 T, 1.8 T quattro, 1.9 TDI, 2.0, 2.0 FSI, 2.0 TDI, 2.0 TDI 16V, 2.0 TDI quattro, 2.0 TFSI, 2.0 TFSI quattro, 2.5 TDI, 2.7 TDI, 3.0, 3.0 quattro, 3.0 TDI quattro, 3.2 FSI, 3.2 FSI quattro		<b>F8-5994</b>		H=85
Control Arm-/Trailing Arm Bush	All Models		<b>F8-6151</b>		d=12; D=40; W=37
Top Strut Mounting	All Models		<b>F8-6352</b>		
Belt Pulley, crankshaft	1.9 TDI	ch.→8E-3-410000; Number of Ribs: 7	<b>F8-6391</b>		
Belt Pulley, crankshaft	1.9 TDI	ch.8E-3-410001-; Number of Ribs: 5; Parameter: 6PK	<b>F8-6396</b>		H=41.6; d=30; Mounting points diam.[mm]=7, 8.6; D=139.7
Belt Pulley, crankshaft	2.0 TDI, 2.0 TDI 16V, 2.0 TDI quattro	Number of Ribs: 5; Parameter: 6PK	<b>F8-6396</b>		H=41.6; d=30; Mounting points diam.[mm]=7, 8.6; D=139.7
Control Arm-/Trailing Arm Bush	All Models		<b>F8-6580</b>		d=12.1; L=80; D=65
Mounting, automatic transmission	1.8 T quattro, 2.0 TDI quattro, 2.0 TFSI quattro, 3.0 quattro, 3.0 TDI quattro, 3.2 FSI quattro, S4 quattro		<b>F8-6737</b>		

<b>AK-735101</b>	<b>F5-1004</b>	<b>F5-1006</b>	<b>F5-1044</b>	<b>F8-4045</b>	<b>F8-5575</b>	<b>F8-5650</b>
Ref.Nr.: 4D0412137C	Ref.Nr.: 038903119T	Ref.Nr.: 038903119M	Ref.Nr.: 06B903119B	Ref.Nr.: 4D0407182E	Ref.Nr.: 8D0399415D	Ref.Nr.: 06A105243E
<b>F8-5994</b>	<b>F8-6151</b>	<b>F8-6352</b>	<b>F8-6391</b>	<b>F8-6396</b>	<b>F8-6580</b>	<b>F8-6737</b>
Ref.Nr.: 8D0412131F	Ref.Nr.: 8E0407181B	Ref.Nr.: 4F0513353B	Ref.Nr.: 038105243F	Ref.Nr.: 03G105243	Ref.Nr.: 4F0407183C	Ref.Nr.: 8E0599125J
<b>F8-8133</b>	<b>F8-8143</b>	<b>F8-8179</b>	<b>MK-810160</b>			
Ref.Nr.: 8E0505203D	Ref.Nr.: 8E0399105HB	Ref.Nr.: 8D0399151R	Ref.Nr.: 3D0 498 201			

**Article Description****Article Nr.****Fitting Position**

<b>A4 (8EC, B7)</b>		<b>11/2004 → 06/2008</b>			
Mounting, automatic transmission	1.8 T quattro, 2.0 TFSI quattro, 3.0 quattro, 3.0 TDI quattro	6-speed	<b>F8-6737</b>		
Mounting, automatic transmission	RS4 quattro		<b>F8-6738</b>		
Mounting, automatic transmission	S4 quattro	ch.8E-4-293001 →;  6-speed	<b>F8-6738</b>		
Engine Mounting	3.2 FSI, 3.2 FSI quattro	6-speed	<b>F8-6961</b>		
Top Strut Mounting	All Models		<b>F8-7451</b>		
Rubber Buffer, suspension	1.9 TDI, 2.0 TDI, 2.0 TDI 16V, 2.0 TDI quattro, 2.0 TFSI, 2.0 TFSI quattro, 2.5 TDI, 2.7 TDI, 3.0, 3.0 quattro, 3.0 TDI quattro, 3.2 FSI, 3.2 FSI quattro	for OE: 1BA; ☆	<b>F8-7577</b>		H=94
Rubber Buffer, suspension	1.6, 1.8 T, 1.8 T quattro, 1.9 TDI, 2.0, 2.0 FSI, 2.0 TDI, 2.0 TDI 16V, 2.0 TDI quattro, 2.0 TFSI, 2.0 TFSI quattro, 2.5 TDI, 2.7 TDI, 3.0, 3.0 quattro, 3.0 TDI quattro, 3.2 FSI, 3.2 FSI quattro	for OE: 1BA;	<b>F8-7578</b>		H=146
Protective Cap/Bellow, shock absorber	All Models		<b>F8-7682</b>		H=160
Protective Cap/Bellow, shock absorber	All Models		<b>F8-7687</b>		H=80
Rubber Buffer, suspension	All Models	ch.8E-5-400001 →;	<b>F8-7707</b>		H=100
Control Arm-/Trailing Arm Bush	1.6, 1.8 T, 1.8 T quattro, 1.9 TDI, 2.0, 2.0 FSI, 2.0 TDI, 2.0 TDI 16V, 2.0 TDI quattro, 2.0 TFSI, 2.0 TFSI quattro, 2.5 TDI, 2.7 TDI, 3.0, 3.0 quattro, 3.0 TDI quattro, 3.2 FSI, 3.2 FSI quattro		<b>F8-7796</b>		H=40; d=10; D=46,5
Control Arm-/Trailing Arm Bush	RS4 quattro, S4 quattro	ch.→8E-5-600000	<b>F8-7796</b>		H=40; d=10; D=46,5
Protective Cap/Bellow, shock absorber	1.6, 1.8 T, 1.8 T quattro, 1.9 TDI, 2.0, 2.0 TDI, 2.0 TDI 16V, 2.0 TDI quattro, 2.0 TFSI, 2.0 TFSI quattro, 2.5 TDI, 2.7 TDI, 3.0 TDI quattro, 3.2 FSI, 3.2 FSI quattro	for OE: 1BR;	<b>F8-7802</b>		H=156
Stabiliser Mounting	1.6, 1.8 T, 1.8 T quattro, 1.9 TDI, 2.0, 2.0 TDI, 2.0 TDI 16V, 2.0 TDI quattro, 2.0 TFSI, 2.0 TFSI quattro, 2.5 TDI, 2.7 TDI, 3.0, 3.0 quattro, 3.0 TDI quattro, 3.2 FSI, 3.2 FSI quattro, RS4 quattro, S4 quattro		<b>F8-7922</b>		d=29
Engine Mounting	1.9 TDI, 2.0 TDI, 2.0 TDI 16V, 2.0 TDI quattro		<b>F8-7969</b>		
Mounting, manual transmission	3.0 TDI quattro	6-speed	<b>F8-7971</b>		
Stabiliser Mounting	1.6, 1.8 T, 1.8 T quattro, 1.9 TDI, 2.0, 2.0 TDI, 2.0 TDI 16V, 2.0 TDI quattro, 2.0 TFSI, 2.0 TFSI quattro, 2.5 TDI, 2.7 TDI, 3.0, 3.0 quattro, 3.0 TDI quattro, 3.2 FSI, 3.2 FSI quattro	Stabi. Diam. [mm]= 16	<b>F8-7979</b>		
Engine Mounting	1.6, 1.8 T, 1.9 TDI, 2.0		<b>F8-8143</b>		
Engine Mounting	1.6, 1.8 T, 1.8 T quattro, 2.0, 2.0 TFSI, 2.0 TFSI quattro		<b>F8-8171</b>		
Bellow Set, drive shaft	1.8 T	with clamps	<b>MK-810160</b>		L=116
Bellow Set, drive shaft	2.0	with clamps; Transmission Type: FJP	<b>MK-810160</b>		L=116

<b>F8-6737</b>	<b>F8-6738</b>	<b>F8-6961</b>	<b>F8-7451</b>	<b>F8-7577</b>	<b>F8-7578</b>	<b>F8-7682</b>
Ref.Nr.: 8E0599125J	Ref.Nr.: 8E0599125K	Ref.Nr.: 8E0199379AF	Ref.Nr.: 8E0412377C	Ref.Nr.: 8D0 412 131 H	Ref.Nr.: 4F0 512 131	Ref.Nr.: 8E0512137E
<b>F8-7687</b>	<b>F8-7707</b>	<b>F8-7796</b>	<b>F8-7802</b>	<b>F8-7922</b>	<b>F8-7969</b>	<b>F8-7971</b>
Ref.Nr.: 4D0412137B	Ref.Nr.: 4F0512131A	Ref.Nr.: 8D0407515C	Ref.Nr.: 4B0512137B	Ref.Nr.: 4D0411327J	Ref.Nr.: 8E0199382K	Ref.Nr.: 4B0399151M
<b>F8-7979</b>	<b>F8-8143</b>	<b>F8-8171</b>	<b>MK-810160</b>			
Ref.Nr.: 4B0511327	Ref.Nr.: 8E0399105HB	Ref.Nr.: 8E0199382J	Ref.Nr.: 3D0 498 201			

**Article Description**

**Article Nr.**
**Fitting Position**

**A4 Avant (8ED, B7)**
**11/2004 → 06/2008**

Alternator Freewheel Clutch	1.9 TDI, 2.0 TDI, 2.0 TDI 16V, 2.0 TDI quattro		<b>F5-1004</b>		
Alternator Freewheel Clutch	1.9 TDI		<b>F5-1006</b>		
Alternator Freewheel Clutch	1.6, 1.8 T, 1.8 T quattro, 2.0, 2.0 TFSI, 2.0 TFSI quattro		<b>F5-1044</b>		
Control Arm-/Trailing Arm Bush	All Models		<b>F8-4045</b>		H1=31; H2=60; d=12; D=50
Mounting, automatic transmission	1.9 TDI		<b>F8-5575</b>		H=72; D=71
Belt Pulley, crankshaft	1.8 T, 2.0		<b>F8-5650</b>		
Rubber Buffer, suspension	1.6, 1.8 T, 1.8 T quattro, 1.9 TDI, 2.0, 2.0 FSi, 2.0 TDI, 2.0 TDI 16V, 2.0 TDI quattro, 2.0 TFSI, 2.0 TFSI quattro, 2.5 TDI, 2.7 TDI, 3.0, 3.0 quattro, 3.0 TDI quattro, 3.2 FSI, 3.2 FSI quattro		<b>F8-5994</b>		H=85
Control Arm-/Trailing Arm Bush	All Models		<b>F8-6151</b>		d=12; D=40; W=37
Top Strut Mounting	All Models		<b>F8-6352</b>		
Belt Pulley, crankshaft	1.9 TDI	ch.→8E-3-410000; Number of Ribs: 7	<b>F8-6391</b>		
Belt Pulley, crankshaft	1.9 TDI	ch.8E-3-410001→; Number of Ribs: 5; Parameter: 6PK	<b>F8-6396</b>		H=41.6; d=30; Mounting points diam.[mm]=7, 8.6; D=139.7
Belt Pulley, crankshaft	2.0 TDI, 2.0 TDI 16V, 2.0 TDI quattro	Number of Ribs: 5; Parameter: 6PK	<b>F8-6396</b>		H=41.6; d=30; Mounting points diam.[mm]=7, 8.6; D=139.7
Control Arm-/Trailing Arm Bush	All Models		<b>F8-6580</b>		d=12.1; L=80; D=65
Mounting, automatic transmission	1.8 T quattro, 2.0 TDI quattro, 2.0 TFSI quattro, 3.0 quattro, 3.0 TDI quattro, 3.2 FSI quattro, S4 quattro		<b>F8-6737</b>		
Mounting, automatic transmission	1.8 T quattro, 2.0 TFSI quattro, 3.0 quattro, 3.0 TDI quattro	6-speed	<b>F8-6737</b>		
Mounting, automatic transmission	RS4 quattro		<b>F8-6738</b>		
Mounting, automatic transmission	S4 quattro	01/2005 →;  6-speed	<b>F8-6738</b>		
Engine Mounting	3.2 FSI, 3.2 FSI quattro	6-speed	<b>F8-6961</b>		
Top Strut Mounting	All Models		<b>F8-7451</b>		
Rubber Buffer, suspension	1.9 TDI, 2.0 TDI, 2.0 TDI 16V, 2.0 TDI quattro, 2.0 TFSI, 2.0 TFSI quattro, 2.5 TDI, 2.7 TDI, 3.0, 3.0 quattro, 3.0 TDI quattro, 3.2 FSI, 3.2 FSI quattro	for OE: 1BA;	<b>F8-7577</b>		H=94
Rubber Buffer, suspension	1.6, 1.8 T, 1.8 T quattro, 1.9 TDI, 2.0, 2.0 FSi, 2.0 TDI, 2.0 TDI 16V, 2.0 TDI quattro, 2.0 TFSI, 2.0 TFSI quattro, 2.5 TDI, 2.7 TDI, 3.0, 3.0 quattro, 3.0 TDI quattro, 3.2 FSI, 3.2 FSI quattro	for OE: 1BA;	<b>F8-7578</b>		H=146
Protective Cap/Bellow, shock absorber	2.0 TFSI		<b>F8-7681</b>		H=100
Protective Cap/Bellow, shock absorber	All Models		<b>F8-7682</b>		H=160

<b>F5-1004</b>	<b>F5-1006</b>	<b>F5-1044</b>	<b>F8-4045</b>	<b>F8-5575</b>	<b>F8-5650</b>	<b>F8-5994</b>
Ref.Nr.: 038903119T	Ref.Nr.: 038903119M	Ref.Nr.: 06B903119B	Ref.Nr.: 4D0407182E	Ref.Nr.: 8D0399415D	Ref.Nr.: 06A105243E	Ref.Nr.: 8D0412131F
<b>F8-6151</b>	<b>F8-6352</b>	<b>F8-6391</b>	<b>F8-6396</b>	<b>F8-6580</b>	<b>F8-6737</b>	<b>F8-6738</b>
Ref.Nr.: 8E0407181B	Ref.Nr.: 4F0513353B	Ref.Nr.: 038105243F	Ref.Nr.: 03G105243	Ref.Nr.: 4F0407183C	Ref.Nr.: 8E0599125J	Ref.Nr.: 8E0599125K
<b>F8-6961</b>	<b>F8-7451</b>	<b>F8-7577</b>	<b>F8-7578</b>	<b>F8-7681</b>	<b>F8-7682</b>	<b>F8-7687</b>
Ref.Nr.: 8E0199379AF	Ref.Nr.: 8E0412377C	Ref.Nr.: 8D0 412 131 H	Ref.Nr.: 4F0 512 131	Ref.Nr.: 8K0412137A	Ref.Nr.: 8E0512137E	Ref.Nr.: 4D0412137B

**Article Description****Article Nr.****Fitting Position**

<b>A4 Avant (8ED, B7)</b>			<b>11/2004 → 06/2008</b>		
Protective Cap/Bellow, shock absorber	All Models		<b>F8-7687</b>		H=80
Rubber Buffer, suspension	2.0 TFSI	for OE: 1BA	<b>F8-7704</b>		H=145
Rubber Buffer, suspension	1.6, 1.8 T, 1.8 T quattro, 1.9 TDI, 2.0, 2.0 FSI, 2.0 TDI, 2.0 TDI 16V, 2.0 TDI quattro, 2.0 TFSI, 2.0 TFSI quattro, 2.5 TDI, 2.7 TDI, 3.0, 3.0 quattro, 3.0 TDI quattro, 3.2 FSI, 3.2 FSI quattro, S4 quattro	ch.8E-5-400001→; <b>SP</b>	<b>F8-7707</b>		H=100
Rubber Buffer, suspension	2.0 TDI, 2.0 TDI quattro, 2.0 TFSI, 2.0 TFSI quattro, 2.7 TDI, 3.0 TDI quattro, RS4 quattro	<b>SP</b>	<b>F8-7707</b>		H=100
Control Arm-/Trailing Arm Bush	1.6, 1.8 T, 1.8 T quattro, 1.9 TDI, 2.0, 2.0 FSI, 2.0 TDI, 2.0 TDI 16V, 2.0 TDI quattro, 2.0 TFSI, 2.0 TFSI quattro, 2.5 TDI, 2.7 TDI, 3.0, 3.0 quattro, 3.0 TDI quattro, 3.2 FSI, 3.2 FSI quattro		<b>F8-7796</b>		H=40; d=10; D=46,5
Control Arm-/Trailing Arm Bush	RS4 quattro, S4 quattro	ch.→8E-5-600000	<b>F8-7796</b>		H=40; d=10; D=46,5
Protective Cap/Bellow, shock absorber	1.6, 1.8 T, 1.8 T quattro, 1.9 TDI, 2.0, 2.0 TDI, 2.0 TDI 16V, 2.0 TDI quattro, 2.0 TFSI, 2.0 TFSI quattro, 2.5 TDI, 2.7 TDI, 3.0 TDI quattro, 3.2 FSI, 3.2 FSI quattro	for OE: 1BR;	<b>F8-7802</b>		H=156
Stabiliser Mounting	1.6, 1.8 T, 1.8 T quattro, 1.9 TDI, 2.0, 2.0 TDI, 2.0 TDI 16V, 2.0 TDI quattro, 2.0 TFSI, 2.0 TFSI quattro, 2.5 TDI, 2.7 TDI, 3.0, 3.0 quattro, 3.0 TDI quattro, 3.2 FSI, 3.2 FSI quattro, RS4 quattro, S4 quattro		<b>F8-7922</b>		d=29
Engine Mounting	1.9 TDI, 2.0 TDI, 2.0 TDI 16V, 2.0 TDI quattro		<b>F8-7969</b>		
Mounting, manual transmission	3.0 TDI quattro	6-speed	<b>F8-7971</b>		
Stabiliser Mounting	1.6, 1.8 T, 1.8 T quattro, 1.9 TDI, 2.0, 2.0 TDI, 2.0 TDI 16V, 2.0 TDI quattro, 2.0 TFSI, 2.0 TFSI quattro, 2.5 TDI, 2.7 TDI, 3.0, 3.0 quattro, 3.0 TDI quattro, 3.2 FSI, 3.2 FSI quattro	Stabi. Diam. [mm]= 16	<b>F8-7979</b>		
Engine Mounting	1.6, 1.8 T, 1.9 TDI, 2.0		<b>F8-8143</b>		
Engine Mounting	1.6, 1.8 T, 1.8 T quattro, 2.0, 2.0 TFSI, 2.0 TFSI quattro		<b>F8-8171</b>		
Bellow Set, drive shaft	2.0	with clamps; Transmission Type: FJP	<b>MK-810160</b>		L=116
<b>A4 Convertible (8H7, B6, 8HE, B7)</b>			<b>04/2002 → 03/2009</b>		
Dust Cover Kit, shock absorber	1.8 T, 1.8 T quattro, 2.0, 2.4, 2.5 TDI, 3.0, 3.0 quattro		<b>AK-735101</b>		
Alternator Freewheel Clutch	2.0 TDI		<b>F5-1004</b>		
Alternator Freewheel Clutch	1.8, 1.8 T, 1.8 T quattro, 2.0, 2.0 TFSI 16V, 2.0 TFSI quattro		<b>F5-1044</b>		
Control Arm-/Trailing Arm Bush	1.8, 1.8 T, 1.8 T quattro, 2.0, 2.0 TDI, 2.0 TFSI 16V, 2.0 TFSI quattro, 2.4, 2.5 TDI, 2.7 TDI, 3.0, 3.0 quattro, 3.0 TDI quattro, 3.2 FSI, 3.2 FSI quattro, RS4 quattro, S4 quattro		<b>F8-4045</b>		H1=31; H2=60; d=12; D=50
Control Arm-/Trailing Arm Bush	1.8 T, 1.8 T quattro, 2.0, 3.0 quattro	ch.→8H-5-014475; for OE: 1BA, 1BE; <b>SP, ST</b>	<b>F8-5542</b>		H=40; d=10; D=46
Control Arm-/Trailing Arm Bush	2.4, 2.5 TDI, 3.0		<b>F8-5542</b>		H=40; d=10; D=46

<b>AK-735101</b>	<b>F5-1004</b>	<b>F5-1044</b>	<b>F8-4045</b>	<b>F8-5542</b>	<b>F8-5650</b>	<b>F8-7687</b>
Ref.Nr.: 4D0412137C	Ref.Nr.: 038903119T	Ref.Nr.: 06B903119B	Ref.Nr.: 4D0407182E	Ref.Nr.: 4B0407515	Ref.Nr.: 06A105243E	Ref.Nr.: 4D0412137B
<b>F8-7704</b>	<b>F8-7707</b>	<b>F8-7796</b>	<b>F8-7802</b>	<b>F8-7922</b>	<b>F8-7969</b>	<b>F8-7971</b>
Ref.Nr.: 8K0512131H	Ref.Nr.: 4F0512131A	Ref.Nr.: 8D0407515C	Ref.Nr.: 4B0512137B	Ref.Nr.: 4D0411327J	Ref.Nr.: 8E0199382K	Ref.Nr.: 4B0399151M
<b>F8-7979</b>	<b>F8-8143</b>	<b>F8-8171</b>	<b>MK-810160</b>			
Ref.Nr.: 4B0511327	Ref.Nr.: 8E0399105HB	Ref.Nr.: 8E0199382J	Ref.Nr.: 3D0 498 201			

Article Description



Article Nr.

Fitting Position



**A4 Convertible (8H7, B6, 8HE, B7)**

04/2002 → 03/2009

Belt Pulley, crankshaft	1.8 T, 2.0		<b>F8-5650</b>		
Rubber Buffer, suspension	1.8 T, 1.8 T quattro, 2.0, 2.0 TDI, 2.0 TFSI 16V, 2.0 TFSi quattro, 2.4, 2.5 TDI, 2.7 TDI, 3.0, 3.0 quattro, 3.0 TDI quattro, 3.2 FSI, 3.2 FSI quattro		<b>F8-5994</b>		H=85
Control Arm-/Trailing Arm Bush	1.8 T, 1.8 T quattro, 2.0, 2.0 TDI, 2.0 TFSI 16V, 2.0 TFSi quattro, 2.4, 2.5 TDI, 2.7 TDI, 3.0, 3.0 quattro, 3.0 TDI quattro, 3.2 FSI, 3.2 FSI quattro		<b>F8-6151</b>		d=12; D=40; W=37
Top Strut Mounting	1.8, 1.8 T, 1.8 T quattro, 2.0, 2.0 TDI, 2.0 TFSI 16V, 2.0 TFSi quattro, 2.4, 2.5 TDI, 2.7 TDI, 3.0, 3.0 quattro, 3.0 TDI quattro, 3.2 FSI, 3.2 FSI quattro, RS4 quattro, S4 quattro		<b>F8-6352</b>		
Control Arm-/Trailing Arm Bush	2.0 TDI, 2.0 TFSI 16V, 3.0 TDI quattro		<b>F8-6580</b>		d=12.1; L=80; D=65
Mounting, automatic transmission	1.8 T quattro, 3.0 TDI quattro, 3.2 FSI quattro	01/2007 →;	<b>F8-6737</b>		
Mounting, automatic transmission	1.8 T quattro, 3.0 TDI quattro, 3.2 FSI quattro	01/2007 →;	<b>F8-6737</b>		
Mounting, automatic transmission	3.0 quattro	ch.8H-4-028051 →;  5-speed	<b>F8-6737</b>		
Mounting, automatic transmission	S4 quattro	ch.8H-4-028051 →;  6-speed	<b>F8-6737</b>		
Mounting, automatic transmission	1.8 T quattro, 3.0 quattro, S4 quattro	ch.8H-4-028051 →;  6-speed	<b>F8-6738</b>		
Mounting, automatic transmission	RS4 quattro		<b>F8-6738</b>		
Engine Mounting	2.4	ch. →8E-5-012800;	<b>F8-6892</b>		
Engine Mounting	2.4	ch. →BE-5-012800	<b>F8-6892</b>		
Engine Mounting	3.0, 3.0 quattro	ch. →8E-5-012800	<b>F8-6892</b>		
Engine Mounting	2.4		<b>F8-6961</b>		
Engine Mounting	2.4, 3.0, 3.0 quattro		<b>F8-6961</b>		
Top Strut Mounting	1.8, 1.8 T, 1.8 T quattro, 2.0, 2.0 TDI, 2.0 TFSI 16V, 2.0 TFSi quattro, 2.4, 2.5 TDI, 2.7 TDI, 3.0, 3.0 quattro, 3.0 TDI quattro, 3.2 FSI, 3.2 FSI quattro, RS4 quattro, S4 quattro		<b>F8-7451</b>		
Rubber Buffer, suspension	RS4 quattro, S4 quattro		<b>F8-7577</b>		H=94
Rubber Buffer, engine mounting	1.8 T, 1.8 T quattro, 2.0, 2.4, 2.5 TDI, 3.0, 3.0 quattro, S4 quattro		<b>F8-7599</b>		
Protective Cap/Bellow, shock absorber	1.8, 1.8 T, 1.8 T quattro, 2.0, 2.0 TDI, 2.0 TFSI 16V, 2.0 TFSi quattro, 2.4, 2.5 TDI, 2.7 TDI, 3.0, 3.0 quattro, 3.0 TDI quattro, 3.2 FSI, 3.2 FSI quattro, RS4 quattro, S4 quattro		<b>F8-7682</b>		H=160
Protective Cap/Bellow, shock absorber	1.8 T, 1.8 T quattro, 2.0, 2.0 TDI, 2.0 TFSI 16V, 2.4, 2.5 TDI, 2.7 TDI, 3.0, 3.0 quattro, 3.0 TDI quattro, 3.2 FSI, 3.2 FSI quattro, RS4 quattro, S4 quattro		<b>F8-7687</b>		H=80

<b>F8-5650</b>	<b>F8-5994</b>	<b>F8-6151</b>	<b>F8-6352</b>	<b>F8-6580</b>	<b>F8-6737</b>	<b>F8-6738</b>
Ref.Nr.: 06A105243E	Ref.Nr.: 8D0412131F	Ref.Nr.: 8E0407181B	Ref.Nr.: 4F0513353B	Ref.Nr.: 4F0407183C	Ref.Nr.: 8E0599125J	Ref.Nr.: 8E0599125K
<b>F8-6892</b>	<b>F8-6961</b>	<b>F8-7451</b>	<b>F8-7577</b>	<b>F8-7599</b>	<b>F8-7682</b>	<b>F8-7687</b>
Ref.Nr.: 8E0199379F	Ref.Nr.: 8E0199379AF	Ref.Nr.: 8E0412377C	Ref.Nr.: 8D0 412 131 H	Ref.Nr.: 8E0 199 339	Ref.Nr.: 8E0512137E	Ref.Nr.: 4D0412137B
<b>F8-7707</b>						
Ref.Nr.: 4F0512131A						

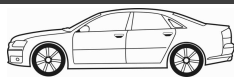

**Article Description****Article Nr.****Fitting Position**

<b>A4 Convertible (8H7, B6, 8HE, B7)</b>				<b>04/2002 → 03/2009</b>	
Rubber Buffer, suspension	1.8 T, 2.0 TDI, 2.0 TFSI 16V, 2.7 TDI, 3.0 TDI quattro, 3.2 FSI, 3.2 FSI quattro	<b>SP, ST</b>	<b>F8-7707</b>		H=100
Rubber Buffer, suspension	S4 quattro	ch.8E-5-400001 →; <b>SP</b>	<b>F8-7707</b>		H=100
Control Arm-/Trailing Arm Bush	1.8	ch.8H-5-014476 →; <b>ST</b>	<b>F8-7796</b>	⊕ ⊕ ↑	H=40; d=10; D=46,5
Control Arm-/Trailing Arm Bush	1.8	for OE: 1BD, 1BV; <b>SP</b>	<b>F8-7796</b>	⊕ ⊕ ↑	H=40; d=10; D=46,5
Control Arm-/Trailing Arm Bush	1.8 T, 1.8 T quattro, 2.4, 3.0, 3.0 quattro	ch.8H-5-014476 →; for OE: 1BA, 1BE	<b>F8-7796</b>	⊕ ⊕ ↑	H=40; d=10; D=46,5
Control Arm-/Trailing Arm Bush	1.8 T, 1.8 T quattro, 2.4, 3.0, 3.0 quattro	for OE: 1BD, 1BV	<b>F8-7796</b>	⊕ ⊕ ↑	H=40; d=10; D=46,5
Control Arm-/Trailing Arm Bush	2.0, 2.0 TDI, 2.0 TFSI 16V, 2.0 TFSI quattro, 2.7 TDI, 3.0 TDI quattro, 3.2 FSI, 3.2 FSI quattro, RS4 quattro, S4 quattro		<b>F8-7796</b>	⊕ ⊕ ↑	H=40; d=10; D=46,5
Control Arm-/Trailing Arm Bush	2.5 TDI	ch.8H-5-014476 →;  BCZ; for OE: 1BA, 1BE	<b>F8-7796</b>	⊕ ⊕ ↑	H=40; d=10; D=46,5
Control Arm-/Trailing Arm Bush	2.5 TDI	ch.8H-5-014476 →;  BDG; for OE: 1BA, 1BE	<b>F8-7796</b>	⊕ ⊕ ↑	H=40; d=10; D=46,5
Control Arm-/Trailing Arm Bush	2.5 TDI	BCZ; for OE: 1BD, 1BV	<b>F8-7796</b>	⊕ ⊕ ↑	H=40; d=10; D=46,5
Control Arm-/Trailing Arm Bush	2.5 TDI	BDG; for OE: 1BD, 1BV	<b>F8-7796</b>	⊕ ⊕ ↑	H=40; d=10; D=46,5
Stabiliser Mounting	1.8 T, 1.8 T quattro, 2.0, 2.0 TDI, 2.0 TFSI 16V, 2.4, 2.5 TDI, 2.7 TDI, 3.0, 3.0 quattro, 3.0 TDI quattro, 3.2 FSI, 3.2 FSI quattro, RS4 quattro, S4 quattro		<b>F8-7922</b>	⊕ ⊕	d=29
Engine Mounting	2.0 TDI		<b>F8-7969</b>	⊕	
Stabiliser Mounting	1.8 T, 1.8 T quattro, 2.0, 2.0 TDI, 2.4, 2.5 TDI, 3.0, 3.0 quattro, 3.0 TDI quattro, 3.2 FSI, 3.2 FSI quattro, S4 quattro		<b>F8-7979</b>	⊕ ⊕	
Control Arm-/Trailing Arm Bush	1.8, 1.8 T, 1.8 T quattro, 2.0, 2.0 TDI, 2.0 TFSI 16V, 2.0 TFSI quattro, 2.4, 2.5 TDI, 2.7 TDI, 3.0, 3.0 quattro, 3.0 TDI quattro, 3.2 FSI, 3.2 FSI quattro, RS4 quattro, S4 quattro		<b>F8-8133</b>	⊕ ⊕	H=60; d=12; D=46
Engine Mounting	1.8 T, 1.8 T quattro, 2.0		<b>F8-8143</b>		
Engine Mounting	1.8 T, 1.8 T quattro, 2.0		<b>F8-8171</b>	⊕	
Mounting, automatic transmission	3.0 quattro		<b>F8-8179</b>	⊕ ⊕	
Bellow Set, drive shaft	1.8 T, 3.0	with clamps	<b>MK-810160</b>		L=116
Bellow Set, drive shaft	2.4, 2.5 TDI	ch. → 8E-3-390000; with clamps	<b>MK-810160</b>		L=116
Bellow Set, drive shaft	2.5 TDI	with clamps; , CVT (Stepless)	<b>MK-810160</b>		L=116
<b>A4 (8K2, B8)</b>				<b>11/2007 → 12/2015</b>	
Alternator Freewheel Clutch	2.0 TDI, 2.0 TDI quattro		<b>F5-1085</b>		
Alternator Freewheel Clutch	2.7 TDI, 3.0 TDI, 3.0 TDI quattro		<b>F5-1140</b>		

<b>F5-1085</b>	<b>F5-1140</b>	<b>F5-1146</b>	<b>F8-7707</b>	<b>F8-7796</b>	<b>F8-7922</b>	<b>F8-7969</b>
Ref.Nr.: 045903119A	Ref.Nr.: 059903119L	Ref.Nr.: 06E903119Q	Ref.Nr.: 4F0512131A	Ref.Nr.: 8D0407515C	Ref.Nr.: 4D0411327J	Ref.Nr.: 8E0199382K
<b>F8-7979</b>	<b>F8-8133</b>	<b>F8-8143</b>	<b>F8-8171</b>	<b>F8-8179</b>	<b>MK-810160</b>	
Ref.Nr.: 4B0511327	Ref.Nr.: 8E0505203D	Ref.Nr.: 8E0399105HB	Ref.Nr.: 8E0199382J	Ref.Nr.: 8D0399151R	Ref.Nr.: 3D0 498 201	

Article Description



Article Nr.

Fitting Position



**A4 (8K2, B8)**

11/2007 → 12/2015

Alternator Freewheel Clutch	3.0 TFSI quattro, 3.2 FSI, 3.2 FSI quattro, S4 quattro		<b>F5-1146</b>		
Belt Pulley, crankshaft	2.0 TDI	Number of Ribs: 5; Parameter: 6PK	<b>F8-6396</b>		H=41.6; d=30; Mounting points diam.[mm]=7, 8.6; D=139.7
Belt Pulley, crankshaft	2.0 TDI	CGLC; Number of Ribs: 5; Parameter: 6PK	<b>F8-6572</b>		
Belt Pulley, crankshaft	2.0 TDI	CGLD; Number of Ribs: 5; Parameter: 6PK	<b>F8-6572</b>		
Belt Pulley, crankshaft	2.0 TDI	CJCA, CMFA; Number of Ribs: 5; Parameter: 6PK	<b>F8-6572</b>		
Belt Pulley, crankshaft	2.0 TDI	CJCB; Number of Ribs: 5; Parameter: 6PK	<b>F8-6572</b>		
Belt Pulley, crankshaft	2.0 TDI quattro	Number of Ribs: 5; Parameter: 6PK	<b>F8-6572</b>		
Belt Pulley, crankshaft	2.0 TDI quattro	CJCA; Number of Ribs: 5; Parameter: 6PK	<b>F8-6572</b>		
Control Arm-/Trailing Arm Bush	1.8 TFSI, 1.8 TFSI quattro, 2.0 TDI, 2.0 TDi quattro, 2.0 TFSI, 2.0 TFSI flexible fuel, 2.0 TFSI flexible fuel quattro, 2.0 TFSI quattro, 2.7 TDI, 3.0 TDI quattro, 3.2 FSI, 3.2 FSI quattro, S4 quattro		<b>F8-6582</b>		
Control Arm-/Trailing Arm Bush	1.8 TFSI, 1.8 TFSI quattro, 2.0 TDI, 2.0 TDi quattro, 2.0 TFSI, 2.0 TFSI flexible fuel, 2.0 TFSI flexible fuel quattro, 2.0 TFSI quattro, 2.7 TDI, 3.0 TDI quattro, 3.2 FSI, 3.2 FSI quattro, S4 quattro		<b>F8-6784</b>		H=45; d=12.2; D=43.8
Top Strut Mounting	1.8 TFSI, 1.8 TFSI quattro, 2.0 TDI, 2.0 TDI quattro, 2.0 TFSI, 2.0 TFSI flexible fuel, 2.0 TFSI flexible fuel quattro, 2.0 TFSI quattro, 2.7 TDI, 3.0 TDI, 3.0 TDI quattro, 3.0 TFSI quattro, 3.2 FSI, 3.2 FSI quattro, S4 quattro		<b>F8-7452</b>		
Protective Cap/Bellow, shock absorber	1.8 TFSI, 1.8 TFSI quattro, 2.0 TDI, 2.0 TDi quattro, 2.0 TFSI, 2.0 TFSI flexible fuel, 2.0 TFSI flexible fuel quattro, 2.0 TFSI quattro, 2.7 TDI, 3.0 TDI quattro, 3.0 TFSI quattro, 3.2 FSI, 3.2 FSI quattro, S4 quattro		<b>F8-7681</b>		H=100
Protective Cap/Bellow, shock absorber	1.8 TFSI, 1.8 TFSI quattro, 2.0 TDI, 2.0 TDi quattro, 2.0 TFSI, 2.0 TFSI flexible fuel, 2.0 TFSI flexible fuel quattro, 2.0 TFSI quattro, 2.7 TDI, 3.0 TDI, 3.0 TDI quattro, 3.0 TFSI quattro, 3.2 FSI, 3.2 FSI quattro, S4 quattro	for OE: 1BA, 1BD, 1BE, 1BV;	<b>F8-7682</b>		H=160
Rubber Buffer, suspension	1.8 TFSI, 1.8 TFSI quattro, 2.0 TDI, 2.0 TDi quattro, 2.0 TFSI, 2.0 TFSI flexible fuel, 2.0 TFSI flexible fuel quattro, 2.0 TFSI quattro, 2.7 TDI, 3.0 TDI quattro, 3.2 FSI, 3.2 FSI quattro, S4 quattro	for OE: 1BA;	<b>F8-7704</b>		H=145
Rubber Buffer, suspension	2.0 TDI	for OE: 1BA	<b>F8-7704</b>		H=145
Rubber Buffer, suspension	1.8 TFSI, 1.8 TFSI quattro, 2.0 TDI, 2.0 TDi quattro, 2.0 TFSI, 2.0 TFSI flexible fuel, 2.0 TFSI flexible fuel quattro, 2.0 TFSI quattro, 2.7 TDI, 3.0 TDI, 3.0 TDI quattro, 3.0 TFSI quattro, 3.2 FSI, 3.2 FSI quattro, S4 quattro	for OE: 1BA, 1BR;	<b>F8-7715</b>		H=81



**Article Description****Article Nr.****Fitting Position**

<b>A4 (8K2, B8)</b>		<b>11/2007 → 12/2015</b>		
Rubber Buffer, suspension	1.8 TFSI, 1.8 TFSI quattro, 2.0 TDI, 2.0 TDi quattro, 2.0 TFSI, 2.0 TFSI flexible fuel, 2.0 TFSI flexible fuel quattro, 2.0 TFSI quattro, 2.7 TDI, 3.0 TDI, 3.0 TDI quattro, 3.0 TFSI quattro, 3.2 FSI, 3.2 FSI quattro, S4 quattro	for OE: 1BD, 1BE; <b>SP</b>	<b>F8-7716</b>	H=72
Rubber Buffer, suspension	1.8 TFSI, 1.8 TFSI quattro, 2.0 TDI, 2.0 TDi quattro, 2.0 TFSI, 2.0 TFSI flexible fuel, 2.0 TFSI flexible fuel quattro, 2.0 TFSI quattro, 2.7 TDI, 3.0 TDI, 3.0 TDI quattro, 3.0 TFSI quattro, 3.2 FSI, 3.2 FSI quattro, S4 quattro	for OE: 1BV; <b>SP</b>	<b>F8-7717</b>	H=66
Rubber Buffer, suspension	1.8 TFSI, 1.8 TFSI quattro, 2.0 TDI, 2.0 TDi quattro, 2.0 TFSI, 2.0 TFSI quattro, 2.7 TDI, 3.0 TDI, 3.0 TDI quattro, 3.2 FSI, 3.2 FSI quattro, S4 quattro	for OE: 1BL;	<b>F8-7717</b>	H=66
Rubber Buffer, suspension	1.8 TFSI, 1.8 TFSI quattro, 2.0 TDI, 2.0 TDi quattro, 2.0 TFSI, 2.0 TFSI flexible fuel, 2.0 TFSI flexible fuel quattro, 2.0 TFSI quattro, 2.7 TDI, 3.0 TDI, 3.0 TDI quattro, 3.0 TFSI quattro, 3.2 FSI, 3.2 FSI quattro, S4 quattro	for OE: 1BD, 1BE; <b>SP</b>	<b>F8-7718</b>	H=118
Rubber Buffer, suspension	1.8 TFSI, 1.8 TFSI quattro, 2.0 TDI, 2.0 TDi quattro, 2.0 TFSI, 2.0 TFSI flexible fuel, 2.0 TFSI flexible fuel quattro, 2.0 TFSI quattro, 2.7 TDI, 3.0 TDI, 3.0 TDI quattro, 3.0 TFSI quattro, 3.2 FSI, 3.2 FSI quattro, S4 quattro	for OE: 1BV; <b>SP</b>	<b>F8-7719</b>	H=110
Rubber Buffer, suspension	1.8 TFSI, 1.8 TFSI quattro, 2.0 TDI, 2.0 TDi quattro, 2.0 TFSI, 2.0 TFSI quattro, 2.7 TDI, 3.0 TDI, 3.0 TDI quattro, 3.2 FSI, 3.2 FSI quattro, S4 quattro	for OE: 1BL;	<b>F8-7719</b>	H=110
Top Strut Mounting	1.8 TFSI, 1.8 TFSI quattro, 2.0 TDI, 2.0 TDi quattro, 2.0 TFSI, 2.0 TFSI flexible fuel, 2.0 TFSI flexible fuel quattro, 2.0 TFSI quattro, 2.7 TDI, 3.0 TDI, 3.0 TDI quattro, 3.0 TFSI quattro, 3.2 FSI, 3.2 FSI quattro, S4 quattro	not for PR: 1BL;	<b>F8-7742</b>	
Protective Cap/Bellow, shock absorber	1.8 TFSI, 1.8 TFSI quattro, 2.0 TDI, 2.0 TDi quattro, 2.0 TFSI, 2.0 TFSI flexible fuel, 2.0 TFSI flexible fuel quattro, 2.0 TFSI quattro, 2.7 TDI, 3.0 TDI, 3.0 TDI quattro, 3.0 TFSI quattro, 3.2 FSI, 3.2 FSI quattro, S4 quattro	for OE: 1BR;	<b>F8-7802</b>	H=156
Protective Cap/Bellow, shock absorber	1.8 TFSI, 1.8 TFSI quattro, 2.0 TDI, 2.0 TDi quattro, 2.0 TFSI, 2.0 TFSI flexible fuel, 2.0 TFSI flexible fuel quattro, 2.0 TFSI quattro, 2.7 TDI, 3.0 TDI, 3.0 TDI quattro, 3.0 TFSI quattro, 3.2 FSI, 3.2 FSI quattro, S4 quattro	for OE: 1BL;	<b>F8-7814</b>	
Rubber Buffer, suspension	All Models	for OE: 1BR;	<b>F8-7839</b>	H=128
Rubber Buffer, suspension	1.8 TFSI, 1.8 TFSI quattro, 2.0 TDI, 2.0 TDi quattro, 2.0 TFSI, 2.0 TFSI flexible fuel, 2.0 TFSI flexible fuel quattro, 2.0 TFSI quattro, 3.0 TDI, 3.0 TDI quattro, 3.0 TFSI quattro	for OE: 1BL;	<b>F8-7840</b>	

<b>F8-7716</b>	<b>F8-7717</b>	<b>F8-7718</b>	<b>F8-7719</b>	<b>F8-7742</b>	<b>F8-7802</b>	<b>F8-7814</b>
Ref.Nr.: 8K0412131F	Ref.Nr.: 8K0412131G	Ref.Nr.: 8K0512131B	Ref.Nr.: 8K0512131D	Ref.Nr.: 8K0412377A	Ref.Nr.: 4B0512137B	Ref.Nr.: 8K0512137A
<b>F8-7839</b>	<b>F8-7840</b>					
Ref.Nr.: 8K0512131J	Ref.Nr.: 8F0512131E					

<b>Article Description</b>			<b>Article Nr.</b>	<b>Fitting Position</b>	
----------------------------	--	--	--------------------	-------------------------	--

<b>A4 (8K2, B8)</b>			<b>11/2007 → 12/2015</b>		
Rubber Buffer, suspension	1.8 TFSI, 1.8 TFSI quattro, 2.0 TDI, 2.0 TDi quattro, 2.0 TFSI, 2.7 TDI, 3.0 TDI quattro, 3.2 FSI, 3.2 FSI quattro, S4 quattro	06/2009 →; for OE: 1BL; ⚡	<b>F8-7840</b>		
Rubber Buffer, suspension	1.8 TFSI, 1.8 TFSI quattro, 2.0 TDI, 2.0 TDi quattro, 2.0 TFSI, 2.0 TFSI flexible fuel, 2.0 TFSI flexible fuel quattro, 2.0 TFSI quattro, 3.0 TDI, 3.0 TDI quattro, 3.0 TFSI quattro	for OE: 1BL; ⚡	<b>F8-7841</b>		H=77
Rubber Buffer, suspension	1.8 TFSI, 1.8 TFSI quattro, 2.0 TDI, 2.0 TDi quattro, 2.0 TFSI, 2.0 TFSI quattro, 2.7 TDI, 3.0 TDI quattro, 3.2 FSI, 3.2 FSI quattro, S4 quattro	11/2009 →; for OE: 1BL; ⚡	<b>F8-7841</b>		H=77
Belt Pulley, crankshaft	1.8 TFSI, 1.8 TFSI quattro, 2.0 TFSI, 2.0 TFSI flexible fuel, 2.0 TFSI flexible fuel quattro, 2.0 TFSI quattro	Number of Ribs: 5; Parameter: 6PK	<b>F8-7880</b>		D=143
Control Arm-/Trailing Arm Bush	1.8 TFSI, 1.8 TFSI quattro, 2.0 TDI, 2.0 TFSI, 2.0 TFSI quattro, 2.7 TDI, 3.0 TDI quattro, 3.2 FSI quattro, S4 quattro		<b>F8-7941</b>		
Engine Mounting	2.0 TDI, 2.0 TDI quattro		<b>F8-7969</b>		
Control Arm-/Trailing Arm Bush	1.8 TFSI, 1.8 TFSI quattro, 2.0 TDI, 2.0 TDi quattro, 2.0 TFSI, 2.0 TFSI flexible fuel, 2.0 TFSI flexible fuel quattro, 2.0 TFSI quattro, 2.7 TDI, 3.0 TDI quattro, 3.2 FSI, 3.2 FSI quattro, S4 quattro	05/2010 →; ⚡, ST	<b>F8-7999</b>		H=80; d=13; D=75
Control Arm-/Trailing Arm Bush	1.8 TFSI, 1.8 TFSI quattro, 2.0 TDI, 2.0 TDi quattro, 2.0 TFSI, 2.0 TFSI quattro, 2.7 TDI, 3.0 TDI quattro, 3.2 FSI, 3.2 FSI quattro	11/2008 →; ⚡	<b>F8-7999</b>		H=80; d=13; D=75
Control Arm-/Trailing Arm Bush	2.0 TDI quattro, 2.0 TFSI flexible fuel, 2.0 TFSI flexible fuel quattro, S4 quattro	⚡	<b>F8-7999</b>		H=80; d=13; D=75
Control Arm-/Trailing Arm Bush	1.8 TFSI, 1.8 TFSI quattro, 2.0 TDI, 2.0 TDi quattro, 2.0 TFSI, 2.0 TFSI flexible fuel, 2.0 TFSI flexible fuel quattro, 2.0 TFSI quattro, 2.7 TDI, 3.0 TDI quattro, 3.2 FSI, 3.2 FSI quattro, S4 quattro		<b>F8-8073</b>		

<b>A4 Allroad (8KH, B8)</b>			<b>04/2009 →</b>		
Alternator Freewheel Clutch	2.0 TDI quattro		<b>F5-1085</b>		
Alternator Freewheel Clutch	3.0 TDI quattro		<b>F5-1140</b>		
Belt Pulley, crankshaft	2.0 TDI quattro	Number of Ribs: 5; Parameter: 6PK	<b>F8-6572</b>		
Belt Pulley, crankshaft	2.0 TDI quattro	CGLD; Number of Ribs: 5; Parameter: 6PK	<b>F8-6572</b>		
Belt Pulley, crankshaft	2.0 TDI quattro	CJCA; Number of Ribs: 5; Parameter: 6PK	<b>F8-6572</b>		
Belt Pulley, crankshaft	2.0 TDI quattro	CJCB; Number of Ribs: 5; Parameter: 6PK	<b>F8-6572</b>		
Control Arm-/Trailing Arm Bush	2.0 TDI quattro, 2.0 TFSI quattro, 3.0 TDI quattro		<b>F8-6582</b>		
Control Arm-/Trailing Arm Bush	2.0 TDI quattro, 2.0 TFSI quattro, 3.0 TDI quattro		<b>F8-6784</b>		H=45; d=12.2; D=43.8
Top Strut Mounting	2.0 TDI quattro, 2.0 TFSI quattro, 3.0 TDI quattro		<b>F8-7452</b>		

<b>F5-1085</b>	<b>F5-1140</b>	<b>F8-6572</b>	<b>F8-6582</b>	<b>F8-6784</b>	<b>F8-7452</b>	<b>F8-7681</b>
Ref.Nr.: 045903119A	Ref.Nr.: 059903119L	Ref.Nr.: 038105243L	Ref.Nr.: 8K0407182A	Ref.Nr.: 4E0407181B	Ref.Nr.: 8K0513353D	Ref.Nr.: 8K0412137A
<b>F8-7840</b>	<b>F8-7841</b>	<b>F8-7880</b>	<b>F8-7941</b>	<b>F8-7969</b>	<b>F8-7999</b>	<b>F8-8073</b>
Ref.Nr.: 8F0512131E	Ref.Nr.: 8F0412131	Ref.Nr.: 06H105243F	Ref.Nr.: 8K0407183A	Ref.Nr.: 8E0199382K	Ref.Nr.: 8K0407183D	Ref.Nr.: 8K0501530N



Article Description



Article Nr.

Fitting Position



<b>A4 Allroad (8KH, B8)</b>			<b>04/2009 →</b>		
Protective Cap/Bellow, shock absorber	2.0 TDI quattro, 2.0 TFSI quattro, 3.0 TDI quattro		<b>F8-7681</b>		H=100
Rubber Buffer, suspension	2.0 TDI quattro, 2.0 TFSI quattro, 3.0 TDI quattro		<b>F8-7704</b>		H=145
Rubber Buffer, suspension	2.0 TDI quattro, 2.0 TFSI quattro, 3.0 TDI quattro		<b>F8-7715</b>		H=81
Top Strut Mounting	2.0 TDI quattro, 2.0 TFSI quattro, 3.0 TDI quattro		<b>F8-7742</b>		
Protective Cap/Bellow, shock absorber	2.0 TDI quattro, 2.0 TFSI quattro, 3.0 TDI quattro		<b>F8-7802</b>		H=156
Belt Pulley, crankshaft	2.0 TFSI quattro	Number of Ribs: 5; Parameter: 6PK	<b>F8-7880</b>		D=143
Control Arm-/Trailing Arm Bush	2.0 TDI quattro, 2.0 TFSI quattro, 3.0 TDI quattro		<b>F8-7941</b>		
Engine Mounting	2.0 TDI quattro		<b>F8-7969</b>		
Control Arm-/Trailing Arm Bush	2.0 TDI quattro, 2.0 TFSI quattro, 3.0 TDI quattro	11/2009 →	<b>F8-7999</b>		H=80; d=13; D=75
Control Arm-/Trailing Arm Bush	2.0 TDI quattro, 2.0 TFSI quattro, 3.0 TDI quattro		<b>F8-8073</b>		
<b>A4 Avant (8K5, B8)</b>			<b>11/2007 → 12/2015</b>		
Alternator Freewheel Clutch	2.0 TDI, 2.0 TDI quattro		<b>F5-1085</b>		
Alternator Freewheel Clutch	2.7 TDI, 3.0 TDI, 3.0 TDI quattro		<b>F5-1140</b>		
Alternator Freewheel Clutch	3.0 TFSI quattro, 3.2 FSI, 3.2 FSI quattro, S4 quattro		<b>F5-1146</b>		
Belt Pulley, crankshaft	2.0 TDI	CGLD; Number of Ribs: 5; Parameter: 6PK	<b>F8-6572</b>		
Belt Pulley, crankshaft	2.0 TDI	CJCA, CMFA; Number of Ribs: 5; Parameter: 6PK	<b>F8-6572</b>		
Belt Pulley, crankshaft	2.0 TDI	CJCB; Number of Ribs: 5; Parameter: 6PK	<b>F8-6572</b>		
Belt Pulley, crankshaft	2.0 TDI quattro	CJCA; Number of Ribs: 5; Parameter: 6PK	<b>F8-6572</b>		
Belt Pulley, crankshaft	2.0 TDI, 2.0 TDI quattro	Number of Ribs: 5; Parameter: 6PK	<b>F8-6572</b>		
Control Arm-/Trailing Arm Bush	1.8 TFSI, 1.8 TFSI quattro, 2.0 TDI, 2.0 TDI quattro, 2.0 TFSI, 2.0 TFSI flexible fuel, 2.0 TFSI flexible fuel quattro, 2.0 TFSI quattro, 2.7 TDI, 3.0 TDI, 3.0 TDI quattro, 3.0 TFSI quattro, 3.2 FSI, 3.2 FSI quattro, RS4 quattro, S4 quattro		<b>F8-6582</b>		
Control Arm-/Trailing Arm Bush	1.8 TFSI, 1.8 TFSI quattro, 2.0 TDI, 2.0 TDI quattro, 2.0 TFSI, 2.0 TFSI flexible fuel, 2.0 TFSI flexible fuel quattro, 2.0 TFSI quattro, 2.7 TDI, 3.0 TDI, 3.0 TDI quattro, 3.0 TFSI quattro, 3.2 FSI, 3.2 FSI quattro, S4 quattro		<b>F8-6784</b>		H=45; d=12.2; D=43.8
Top Strut Mounting	1.8 TFSI, 1.8 TFSI quattro, 2.0 TDI, 2.0 TDI quattro, 2.0 TFSI, 2.0 TFSI flexible fuel, 2.0 TFSI flexible fuel quattro, 2.0 TFSI quattro, 2.7 TDI, 3.0 TDI, 3.0 TDI quattro, 3.0 TFSI quattro, 3.2 FSI, 3.2 FSI quattro, S4 quattro		<b>F8-7452</b>		

<b>F5-1085</b>	<b>F5-1140</b>	<b>F5-1146</b>	<b>F8-6572</b>	<b>F8-6582</b>	<b>F8-6784</b>	<b>F8-7452</b>
Ref.Nr.: 045903119A	Ref.Nr.: 059903119L	Ref.Nr.: 06E903119Q	Ref.Nr.: 038105243L	Ref.Nr.: 8K0407182A	Ref.Nr.: 4E0407181B	Ref.Nr.: 8K0513353D
<b>F8-7681</b>	<b>F8-7704</b>	<b>F8-7715</b>	<b>F8-7742</b>	<b>F8-7802</b>	<b>F8-7880</b>	<b>F8-7941</b>
Ref.Nr.: 8K0412137A	Ref.Nr.: 8K0512131H	Ref.Nr.: 8K0412131E	Ref.Nr.: 8K0412377A	Ref.Nr.: 4B0512137B	Ref.Nr.: 06H105243F	Ref.Nr.: 8K0407183A
<b>F8-7969</b>	<b>F8-7999</b>	<b>F8-8073</b>				
Ref.Nr.: 8E0199382K	Ref.Nr.: 8K0407183D	Ref.Nr.: 8K0501530N				

Article Description



Article Nr.

Fitting Position



**A4 Avant (8K5, B8)**

11/2007 → 12/2015

Protective Cap/Bellow, shock absorber	1.8 TFSI, 1.8 TFSI quattro, 2.0 TDI, 2.0 TDI quattro, 2.0 TFSI, 2.0 TFSI flexible fuel, 2.0 TFSI flexible fuel quattro, 2.0 TFSI quattro, 2.7 TDI, 3.0 TDI, 3.0 TDI quattro, 3.0 TFSI quattro, 3.2 FSI, 3.2 FSI quattro, S4 quattro		<b>F8-7681</b>		H=100
Protective Cap/Bellow, shock absorber	1.8 TFSI, 1.8 TFSI quattro, 2.0 TDI, 2.0 TDI quattro, 2.0 TFSI, 2.0 TFSI flexible fuel, 2.0 TFSI flexible fuel quattro, 2.0 TFSI quattro, 2.7 TDI, 3.0 TDI, 3.0 TDI quattro, 3.0 TFSI quattro, 3.2 FSI, 3.2 FSI quattro, S4 quattro	for OE: 1BA, 1BD, 1BE, 1BV; <b>SP</b> , <b>ST</b>	<b>F8-7682</b>		H=160
Rubber Buffer, suspension	1.8 TFSI, 1.8 TFSI quattro, 2.0 TDI, 2.0 TDI quattro, 2.0 TFSI, 2.0 TFSI flexible fuel, 2.0 TFSI flexible fuel quattro, 2.0 TFSI quattro, 2.7 TDI, 3.0 TDI, 3.0 TDI quattro, 3.2 FSI, 3.2 FSI quattro, S4 quattro	for OE: 1BA; <b>ST</b>	<b>F8-7704</b>		H=145
Rubber Buffer, suspension	2.0 TDI	for OE: 1BA	<b>F8-7704</b>		H=145
Rubber Buffer, suspension	1.8 TFSI, 1.8 TFSI quattro, 2.0 TDI, 2.0 TDI quattro, 2.0 TFSI, 2.0 TFSI flexible fuel, 2.0 TFSI flexible fuel quattro, 2.0 TFSI quattro, 2.7 TDI, 3.0 TDI, 3.0 TDI quattro, 3.0 TFSI quattro, 3.2 FSI, 3.2 FSI quattro, S4 quattro	for OE: 1BA, 1BR; ☆, △, <b>ST</b>	<b>F8-7715</b>		H=81
Rubber Buffer, suspension	1.8 TFSI, 1.8 TFSI quattro, 2.0 TDI, 2.0 TDI quattro, 2.0 TFSI, 2.0 TFSI flexible fuel, 2.0 TFSI flexible fuel quattro, 2.0 TFSI quattro, 2.7 TDI, 3.0 TDI, 3.0 TDI quattro, 3.0 TFSI quattro, 3.2 FSI, 3.2 FSI quattro, S4 quattro	for OE: 1BD, 1BE; <b>SP</b>	<b>F8-7716</b>		H=72
Rubber Buffer, suspension	1.8 TFSI, 1.8 TFSI quattro, 2.0 TDI, 2.0 TDI quattro, 2.0 TFSI, 2.0 TFSI flexible fuel, 2.0 TFSI flexible fuel quattro, 2.0 TFSI quattro, 2.7 TDI, 3.0 TDI, 3.0 TDI quattro, 3.0 TFSI quattro, 3.2 FSI, 3.2 FSI quattro, S4 quattro	for OE: 1BV; <b>SP</b>	<b>F8-7717</b>		H=66
Rubber Buffer, suspension	1.8 TFSI, 1.8 TFSI quattro, 2.0 TDI, 2.0 TDI quattro, 2.0 TFSI, 2.0 TFSI quattro, 2.7 TDI, 3.0 TDI, 3.0 TDI quattro, 3.2 FSI, 3.2 FSI quattro, S4 quattro	for OE: 1BL; †	<b>F8-7717</b>		H=66
Rubber Buffer, suspension	1.8 TFSI, 1.8 TFSI quattro, 2.0 TDI, 2.0 TDI quattro, 2.0 TFSI, 2.0 TFSI flexible fuel, 2.0 TFSI flexible fuel quattro, 2.0 TFSI quattro, 2.7 TDI, 3.0 TDI, 3.0 TDI quattro, 3.0 TFSI quattro, 3.2 FSI, 3.2 FSI quattro, S4 quattro	for OE: 1BD, 1BE; <b>SP</b>	<b>F8-7718</b>		H=118
Rubber Buffer, suspension	RS4 quattro		<b>F8-7718</b>		H=118
Rubber Buffer, suspension	1.8 TFSI, 1.8 TFSI quattro, 2.0 TDI, 2.0 TDI quattro, 2.0 TFSI, 2.0 TFSI flexible fuel, 2.0 TFSI flexible fuel quattro, 2.0 TFSI quattro, 2.7 TDI, 3.0 TDI, 3.0 TDI quattro, 3.0 TFSI quattro, 3.2 FSI, 3.2 FSI quattro, S4 quattro	for OE: 1BV; <b>SP</b>	<b>F8-7719</b>		H=110
Rubber Buffer, suspension	1.8 TFSI, 1.8 TFSI quattro, 2.0 TDI, 2.0 TDI quattro, 2.0 TFSI, 2.0 TFSI quattro, 2.7 TDI, 3.0 TDI, 3.0 TDI quattro, 3.2 FSI, 3.2 FSI quattro, S4 quattro	for OE: 1BL; †	<b>F8-7719</b>		H=110

<b>F8-7681</b>	<b>F8-7682</b>	<b>F8-7704</b>	<b>F8-7715</b>	<b>F8-7716</b>	<b>F8-7717</b>	<b>F8-7718</b>
Ref.Nr.: 8K0412137A	Ref.Nr.: 8E0512137E	Ref.Nr.: 8K0512131H	Ref.Nr.: 8K0412131E	Ref.Nr.: 8K0412131F	Ref.Nr.: 8K0412131G	Ref.Nr.: 8K0512131B
<b>F8-7719</b>	<b>F8-7742</b>					
Ref.Nr.: 8K0512131D	Ref.Nr.: 8K0412377A					

**Article Description****Article Nr.****Fitting Position**

<b>A4 Avant (8K5, B8)</b>		<b>11/2007 → 12/2015</b>	
Top Strut Mounting	1.8 TFSI, 1.8 TFSI quattro, 2.0 TDI, 2.0 TDI quattro, 2.0 TFSI, 2.0 TFSI flexible fuel, 2.0 TFSI flexible fuel quattro, 2.0 TFSI quattro, 2.7 TDI, 3.0 TDI, 3.0 TDI quattro, 3.0 TFSI quattro, 3.2 FSI, 3.2 FSI quattro, S4 quattro	not for PR: 1BL; ✖	<b>F8-7742</b>
Protective Cap/Bellow, shock absorber	1.8 TFSI, 1.8 TFSI quattro, 2.0 TDI, 2.0 TDI quattro, 2.0 TFSI, 2.0 TFSI flexible fuel, 2.0 TFSI flexible fuel quattro, 2.0 TFSI quattro, 2.7 TDI, 3.0 TDI, 3.0 TDI quattro, 3.0 TFSI quattro, 3.2 FSI, 3.2 FSI quattro, S4 quattro	for OE: 1BR; ▲	<b>F8-7802</b>
Protective Cap/Bellow, shock absorber	1.8 TFSI, 1.8 TFSI quattro, 2.0 TDI, 2.0 TDI quattro, 2.0 TFSI, 2.0 TFSI flexible fuel, 2.0 TFSI flexible fuel quattro, 2.0 TFSI quattro, 2.7 TDI, 3.0 TDI, 3.0 TDI quattro, 3.0 TFSI quattro, 3.2 FSI, 3.2 FSI quattro, RS4 quattro, S4 quattro	for OE: 1BL; ↗	<b>F8-7814</b>
Rubber Buffer, suspension	1.8 TFSI, 1.8 TFSI quattro, 2.0 TDI, 2.0 TDI quattro, 2.0 TFSI, 2.0 TFSI flexible fuel, 2.0 TFSI flexible fuel quattro, 2.0 TFSI quattro, 2.7 TDI, 3.0 TDI, 3.0 TDI quattro, 3.0 TFSI quattro, 3.2 FSI, 3.2 FSI quattro, S4 quattro	for OE: 1BR; ▲	<b>F8-7839</b>
Rubber Buffer, suspension	1.8 TFSI, 1.8 TFSI quattro, 2.0 TDI, 2.0 TDI quattro, 2.0 TFSI, 2.0 TFSI flexible fuel, 2.0 TFSI flexible fuel quattro, 2.0 TFSI quattro, 2.7 TDI, 3.0 TDI, 3.0 TDI quattro, 3.0 TFSI quattro, RS4 quattro	for OE: 1BL; ↗	<b>F8-7840</b>
Rubber Buffer, suspension	1.8 TFSI, 1.8 TFSI quattro, 2.0 TDI, 2.0 TDI quattro, 2.0 TFSI, 2.0 TFSI quattro, 2.7 TDI, 3.0 TDI quattro, 3.2 FSI, 3.2 FSI quattro, S4 quattro	06/2009 →; for OE: 1BL; ↗	<b>F8-7840</b>
Rubber Buffer, suspension	1.8 TFSI, 1.8 TFSI quattro, 2.0 TDI, 2.0 TDI quattro, 2.0 TFSI, 2.0 TFSI flexible fuel, 2.0 TFSI flexible fuel quattro, 2.0 TFSI quattro, 2.7 TDI, 3.0 TDI quattro, 3.0 TFSI quattro, RS4 quattro	for OE: 1BL; ↗	<b>F8-7841</b>
Rubber Buffer, suspension	1.8 TFSI, 1.8 TFSI quattro, 2.0 TDI, 2.0 TDI quattro, 2.0 TFSI, 2.0 TFSI quattro, 2.7 TDI, 3.0 TDI quattro, 3.2 FSI, 3.2 FSI quattro, S4 quattro	11/2009 →; for OE: 1BL; ↗	<b>F8-7841</b>
Belt Pulley, crankshaft	1.8 TFSI, 1.8 TFSI quattro, 2.0 TFSI, 2.0 TFSI flexible fuel, 2.0 TFSI flexible fuel quattro, 2.0 TFSI quattro	Number of Ribs: 5; Parameter: 6PK	<b>F8-7880</b>
Control Arm-/Trailing Arm Bush	1.8 TFSI, 1.8 TFSI quattro, 2.0 TDI, 2.0 TDI quattro, 2.0 TFSI, 2.0 TFSI quattro, 2.7 TDI, 3.0 TDI quattro, 3.2 FSI quattro, S4 quattro		<b>F8-7941</b>
Engine Mounting	2.0 TDI, 2.0 TDI quattro		<b>F8-7969</b>
Control Arm-/Trailing Arm Bush	1.8 TFSI, 1.8 TFSI quattro, 2.0 TDI, 2.0 TDI quattro, 2.0 TFSI, 2.0 TFSI flexible fuel, 2.0 TFSI flexible fuel quattro, 2.0 TFSI quattro, 2.7 TDI, 3.0 TDI quattro, 3.2 FSI, 3.2 FSI quattro, S4 quattro	05/2010 →; ✖, ST	<b>F8-7999</b>
Control Arm-/Trailing Arm Bush	1.8 TFSI, 1.8 TFSI quattro, 2.0 TDI, 2.0 TDI quattro, 2.0 TFSI, 2.0 TFSI quattro, 2.7 TDI, 3.0 TDI quattro, 3.2 FSI, 3.2 FSI quattro	11/2008 →; ✖	<b>F8-7999</b>

<b>F8-7742</b>	<b>F8-7802</b>	<b>F8-7814</b>	<b>F8-7839</b>	<b>F8-7840</b>	<b>F8-7841</b>	<b>F8-7880</b>
Ref.Nr.: 8K0412377A	Ref.Nr.: 4B0512137B	Ref.Nr.: 8K0512137A	Ref.Nr.: 8K0512131J	Ref.Nr.: 8F0512131E	Ref.Nr.: 8F0412131	Ref.Nr.: 06H105243F
<b>F8-7941</b>	<b>F8-7969</b>	<b>F8-7999</b>				
Ref.Nr.: 8K0407183A	Ref.Nr.: 8E0199382K	Ref.Nr.: 8K0407183D				

<b>Article Description</b>			<b>Article Nr.</b>	<b>Fitting Position</b>	
----------------------------	--	--	--------------------	-------------------------	--

<b>A4 Avant (8K5, B8)</b>		<b>11/2007 → 12/2015</b>		
Control Arm-/Trailing Arm Bush	2.0 TFSI flexible fuel, 2.0 TFSI flexible fuel quattro, S4 quattro		<b>F8-7999</b>	H=80; d=13; D=75
Control Arm-/Trailing Arm Bush	1.8 TFSI, 1.8 TFSI quattro, 2.0 TDI, 2.0 TDI quattro, 2.0 TFSI, 2.0 TFSI flexible fuel, 2.0 TFSI flexible fuel quattro, 2.0 TFSI quattro, 2.7 TDI, 3.0 TDI quattro, 3.2 FSI, 3.2 FSI quattro, S4 quattro		<b>F8-8073</b>	
<b>A5 (8T3)</b>		<b>06/2007 →</b>		
Alternator Freewheel Clutch	2.0 TDI, 2.0 TDI quattro		<b>F5-1085</b>	
Alternator Freewheel Clutch	2.7 TDI, 3.0 TDI, 3.0 TDI quattro		<b>F5-1140</b>	
Alternator Freewheel Clutch	3.0 TFSI quattro, 3.2 FSI, 3.2 FSI quattro, S5 quattro		<b>F5-1146</b>	
Belt Pulley, crankshaft	2.0 TDI, 2.0 TDI quattro	Number of Ribs: 5; Parameter: 6PK	<b>F8-6396</b>	H=41.6; d=30; Mounting points diam.[mm]=7, 8.6; D=139.7
Belt Pulley, crankshaft	2.0 TDI	CGLD; Number of Ribs: 5; Parameter: 6PK	<b>F8-6572</b>	
Belt Pulley, crankshaft	2.0 TDI, 2.0 TDI quattro	Number of Ribs: 5; Parameter: 6PK	<b>F8-6572</b>	
Control Arm-/Trailing Arm Bush	1.8 TFSI, 2.0 TDI, 2.0 TDI quattro, 2.0 TFSI, 2.0 TFSI quattro, 2.7 TDI, 3.0 TDI, 3.0 TDI quattro, 3.0 TFSI quattro, 3.2 FSI, 3.2 FSI quattro, RS 5 quattro, S5 quattro		<b>F8-6582</b>	
Control Arm-/Trailing Arm Bush	1.8 TFSI, 2.0 TDI, 2.0 TDI quattro, 2.0 TFSI, 2.0 TFSI quattro, 2.7 TDI, 3.0 TDI, 3.0 TDI quattro, 3.0 TFSI quattro, 3.2 FSI, 3.2 FSI quattro, RS 5 quattro, S5 quattro		<b>F8-6784</b>	H=45; d=12.2; D=43.8
Top Strut Mounting	1.8 TFSI, 2.0 TDI, 2.0 TDI quattro, 2.0 TFSI, 2.0 TFSI quattro, 2.7 TDI, 3.0 TDI, 3.0 TDI quattro, 3.2 FSI, 3.2 FSI quattro, RS 5 quattro, S5 quattro		<b>F8-7452</b>	
Protective Cap/Bellow, shock absorber	1.8 TFSI, 2.0 TDI, 2.0 TDI quattro, 2.0 TFSI, 2.0 TFSI quattro, 2.7 TDI, 3.0 TDI, 3.0 TDI quattro, 3.0 TFSI quattro, 3.2 FSI, 3.2 FSI quattro, S5 quattro		<b>F8-7681</b>	H=100
Protective Cap/Bellow, shock absorber	RS 5 quattro	for OE: 2MS	<b>F8-7681</b>	H=100
Protective Cap/Bellow, shock absorber	1.8 TFSI, 2.0 TDI, 2.0 TDI quattro, 2.0 TFSI, 2.0 TFSI quattro, 2.7 TDI, 3.0 TDI, 3.0 TDI quattro, 3.0 TFSI quattro, 3.2 FSI, 3.2 FSI quattro, S5 quattro	for OE: 1BA, 1BD, 1BE, 1BV;	<b>F8-7682</b>	H=160
Rubber Buffer, suspension	1.8 TFSI, 2.0 TDI, 2.0 TDI quattro, 2.0 TFSI, 2.0 TFSI quattro, 2.7 TDI, 3.0 TDI, 3.0 TDI quattro, 3.2 FSI, 3.2 FSI quattro, S5 quattro	for OE: 1BB;	<b>F8-7704</b>	H=145
Rubber Buffer, suspension	S5 quattro	for OE: 1BB	<b>F8-7704</b>	H=145
Rubber Buffer, suspension	1.8 TFSI, 2.0 TDI, 2.0 TDI quattro, 2.0 TFSI, 2.0 TFSI quattro, 2.7 TDI, 3.0 TDI, 3.0 TDI quattro, 3.0 TFSI quattro, 3.2 FSI, 3.2 FSI quattro, S5 quattro	for OE: 1BA, 1BD, 1BE, 1BV;	<b>F8-7716</b>	H=72
Rubber Buffer, suspension	RS 5 quattro	for OE: 2MS;	<b>F8-7716</b>	H=72
Rubber Buffer, suspension	1.8 TFSI, 2.0 TDI, 2.0 TDI quattro, 2.0 TFSI, 2.0 TFSI quattro, 2.7 TDI, 3.0 TDI, 3.0 TDI quattro, 3.2 FSI, 3.2 FSI quattro, RS 5 quattro, S5 quattro	for OE: 1BL;	<b>F8-7717</b>	H=66

<b>F5-1085</b>	<b>F5-1140</b>	<b>F5-1146</b>	<b>F8-6396</b>	<b>F8-6572</b>	<b>F8-6582</b>	<b>F8-6784</b>
Ref.Nr.: 045903119A	Ref.Nr.: 059903119L	Ref.Nr.: 06E903119Q	Ref.Nr.: 03G105243	Ref.Nr.: 038105243L	Ref.Nr.: 8K0407182A	Ref.Nr.: 4E0407181B
<b>F8-7452</b>	<b>F8-7681</b>	<b>F8-7682</b>	<b>F8-7704</b>	<b>F8-7716</b>	<b>F8-7717</b>	<b>F8-7718</b>
Ref.Nr.: 8K0513353D	Ref.Nr.: 8K0412137A	Ref.Nr.: 8E0512137E	Ref.Nr.: 8K0512131H	Ref.Nr.: 8K0412131F	Ref.Nr.: 8K0412131G	Ref.Nr.: 8K0512131B
<b>F8-7999</b>	<b>F8-8073</b>					
Ref.Nr.: 8K0407183D	Ref.Nr.: 8K0501530N					



**Article Description****Article Nr.****Fitting Position**

<b>A5 (8T3)</b>				<b>06/2007 →</b>	
Rubber Buffer, suspension	1.8 TFSI, 2.0 TDI, 2.0 TDI quattro, 2.0 TFSI, 2.0 TFSI quattro, 2.7 TDI, 3.0 TDI, 3.0 TDI quattro, 3.0 TFSI quattro, 3.2 FSI, 3.2 FSI quattro, S5 quattro	for OE: 1BA, 1BD, 1BE, 1BV;	<b>F8-7718</b>		H=118
Rubber Buffer, suspension	RS 5 quattro	for OE: 1BE, 1BV	<b>F8-7718</b>		H=118
Rubber Buffer, suspension	1.8 TFSI, 2.0 TDI, 2.0 TDI quattro, 2.0 TFSI, 2.0 TFSI quattro, 2.7 TDI, 3.0 TDI quattro, 3.2 FSI, 3.2 FSI quattro, S5 quattro	for OE: 1BL;	<b>F8-7719</b>		H=110
Top Strut Mounting	1.8 TFSI, 2.0 TDI, 2.0 TDI quattro, 2.0 TFSI, 2.0 TFSI quattro, 2.7 TDI, 3.0 TDI quattro, 3.2 FSI, 3.2 FSI quattro, S5 quattro	not for PR: 1BL;	<b>F8-7742</b>		
Top Strut Mounting	RS 5 quattro		<b>F8-7742</b>		
Protective Cap/Bellow, shock absorber	1.8 TFSI, 2.0 TDI, 2.0 TDI quattro, 2.0 TFSI, 2.0 TFSI quattro, 2.7 TDI, 3.0 TDI, 3.0 TDI quattro, 3.0 TFSI quattro, 3.2 FSI, 3.2 FSI quattro	for OE: 1BB;	<b>F8-7802</b>		H=156
Protective Cap/Bellow, shock absorber	1.8 TFSI, 2.0 TDI, 2.0 TDI quattro, 2.0 TFSI, 2.0 TFSI quattro, 2.7 TDI, 3.0 TDI, 3.0 TDI quattro, 3.0 TFSI quattro, 3.2 FSI, 3.2 FSI quattro	for OE: 1BB;	<b>F8-7813</b>		H=167
Protective Cap/Bellow, shock absorber	1.8 TFSI, 2.0 TDI, 2.0 TDI quattro, 2.0 TFSI, 2.0 TFSI quattro, 2.7 TDI, 3.0 TDI, 3.0 TDI quattro, 3.0 TFSI quattro, 3.2 FSI, 3.2 FSI quattro, RS 5 quattro, S5 quattro	for OE: 1BL;	<b>F8-7814</b>		
Rubber Buffer, suspension	1.8 TFSI, 2.0 TDI, 2.0 TDI quattro, 2.0 TFSI, 2.0 TFSI quattro, 2.7 TDI, 3.0 TDI quattro, 3.2 FSI, 3.2 FSI quattro, S5 quattro	06/2009 →; for OE: 1BL;	<b>F8-7840</b>		
Rubber Buffer, suspension	2.0 TDI, 2.0 TDI quattro, 2.0 TFSI, 2.0 TFSI quattro, 3.0 TDI, 3.0 TDI quattro, 3.0 TFSI quattro, RS 5 quattro, S5 quattro	for OE: 1BL;	<b>F8-7840</b>		
Rubber Buffer, suspension	1.8 TFSI, 2.0 TDI, 2.0 TDI quattro, 2.0 TFSI, 2.0 TFSI quattro, 2.7 TDI, 3.0 TDI quattro, 3.2 FSI, 3.2 FSI quattro, S5 quattro	11/2009 →; for OE: 1BL;	<b>F8-7841</b>		H=77
Rubber Buffer, suspension	2.0 TDI, 2.0 TDI quattro, 2.0 TFSI, 2.0 TFSI quattro, 3.0 TDI, 3.0 TDI quattro, 3.0 TFSI quattro, RS 5 quattro, S5 quattro	for OE: 1BL;	<b>F8-7841</b>		H=77
Belt Pulley, crankshaft	1.8 TFSI, 2.0 TFSI, 2.0 TFSI quattro	Number of Ribs: 5; Parameter: 6PK	<b>F8-7880</b>		D=143
Control Arm-/Trailing Arm Bush	1.8 TFSI, 2.0 TFSI, 2.0 TFSI quattro, 2.7 TDI, 3.0 TDI quattro, 3.2 FSI, 3.2 FSI quattro, S5 quattro		<b>F8-7941</b>		
Control Arm-/Trailing Arm Bush	1.8 TFSI, 2.0 TDI, 2.0 TDI quattro, 2.0 TFSI quattro, 3.0 TDI, 3.0 TDI quattro, 3.0 TFSI quattro, RS 5 quattro, S5 quattro		<b>F8-7999</b>		H=80; d=13; D=75
Control Arm-/Trailing Arm Bush	1.8 TFSI, 2.0 TDI, 2.0 TDI quattro, 2.0 TFSI, 2.0 TFSI quattro, 2.7 TDI, 3.0 TDI quattro, 3.2 FSI, 3.2 FSI quattro, S5 quattro	07/2009 →	<b>F8-7999</b>		H=80; d=13; D=75
Control Arm-/Trailing Arm Bush	1.8 TFSI, 2.0 TDI, 2.0 TDI quattro, 2.0 TFSI, 2.0 TFSI quattro, 2.7 TDI, 3.0 TDI quattro, 3.2 FSI, 3.2 FSI quattro, RS 5 quattro, S5 quattro		<b>F8-8073</b>		

<b>F5-1085</b>	<b>F8-7718</b>	<b>F8-7719</b>	<b>F8-7742</b>	<b>F8-7802</b>	<b>F8-7813</b>	<b>F8-7814</b>
Ref.Nr.: 045903119A	Ref.Nr.: 8K0512131B	Ref.Nr.: 8K0512131D	Ref.Nr.: 8K0412377A	Ref.Nr.: 4B0512137B	Ref.Nr.: 4G0512137A	Ref.Nr.: 8K0512137A
<b>F8-7840</b>	<b>F8-7841</b>	<b>F8-7880</b>	<b>F8-7941</b>	<b>F8-7999</b>	<b>F8-8073</b>	
Ref.Nr.: 8F0512131E	Ref.Nr.: 8F0412131	Ref.Nr.: 06H105243F	Ref.Nr.: 8K0407183A	Ref.Nr.: 8K0407183D	Ref.Nr.: 8K0501530N	

Article Description



Article Nr.

Fitting Position



**A5 Convertible (8F7)**

03/2009 →

Alternator Freewheel Clutch	2.0 TDI, 2.0 TDI quattro		<b>F5-1085</b>		
Alternator Freewheel Clutch	2.7 TDI, 3.0 TDI, 3.0 TDI quattro		<b>F5-1140</b>		
Alternator Freewheel Clutch	3.0 TFSI quattro, 3.2 FSI, 3.2 FSI quattro, S5 quattro		<b>F5-1146</b>		
Belt Pulley, crankshaft	2.0 TDI	Number of Ribs: 5; Parameter: 6PK	<b>F8-6396</b>		H=41.6; d=30; Mounting points diam.[mm]=7, 8.6; D=139.7
Belt Pulley, crankshaft	2.0 TDI	CGLD; Number of Ribs: 5; Parameter: 6PK	<b>F8-6572</b>		
Belt Pulley, crankshaft	2.0 TDI, 2.0 TDI quattro	Number of Ribs: 5; Parameter: 6PK	<b>F8-6572</b>		
Control Arm-/Trailing Arm Bush	1.8 TFSI, 2.0 TDI, 2.0 TDI quattro, 2.0 TFSI, 2.0 TFSI quattro, 2.7 TDI, 3.0 TDI, 3.0 TDI quattro, 3.0 TFSI quattro, 3.2 FSI, 3.2 FSI quattro, RS 5 quattro, S5 quattro		<b>F8-6582</b>		
Control Arm-/Trailing Arm Bush	1.8 TFSI, 2.0 TDI, 2.0 TDI quattro, 2.0 TFSI, 2.0 TFSI quattro, 2.7 TDI, 3.0 TDI, 3.0 TDI quattro, 3.0 TFSI quattro, 3.2 FSI, 3.2 FSI quattro, S5 quattro		<b>F8-6784</b>		H=45; d=12.2; D=43.8
Top Strut Mounting	1.8 TFSI, 2.0 TDI, 2.0 TFSI, 2.0 TFSI quattro, 2.7 TDI, 3.0 TDI, 3.0 TDI quattro, 3.2 FSI, 3.2 FSI quattro, S5 quattro		<b>F8-7452</b>		
Protective Cap/Bellow, shock absorber	1.8 TFSI, 2.0 TDI, 2.0 TDI quattro, 2.0 TFSI, 2.0 TFSI quattro, 2.7 TDI, 3.0 TDI, 3.0 TDI quattro, 3.0 TFSI quattro, 3.2 FSI, 3.2 FSI quattro, S5 quattro		<b>F8-7681</b>		H=100
Protective Cap/Bellow, shock absorber	1.8 TFSI, 2.0 TDI, 2.0 TFSI, 2.0 TFSI quattro, 2.7 TDI, 3.0 TDI quattro, 3.2 FSI, 3.2 FSI quattro, S5 quattro	for OE: 1BA, 1BD, 1BE, 1BV; →2012; <b>SP, ST</b>	<b>F8-7682</b>		H=160
Rubber Buffer, suspension	2.7 TDI, 3.0 TDI	for OE: 1BB	<b>F8-7704</b>		H=145
Rubber Buffer, suspension	1.8 TFSI, 2.0 TDI, 2.0 TDI quattro, 2.0 TFSI, 2.0 TFSI quattro, 2.7 TDI, 3.0 TDI, 3.0 TDI quattro, 3.0 TFSI quattro, 3.2 FSI, 3.2 FSI quattro, S5 quattro	for OE: 1BA, 1BD, 1BE, 1BV; <b>SP, ST</b>	<b>F8-7716</b>		H=72
Rubber Buffer, suspension	1.8 TFSI, 2.0 TDI, 2.0 TDI quattro, 2.0 TFSI, 2.0 TFSI quattro, 2.7 TDI, 3.0 TDI, 3.0 TDI quattro, 3.0 TFSI quattro, 3.2 FSI, 3.2 FSI quattro, S5 quattro	for OE: 1BA, 1BD, 1BE, 1BV; <b>SP, ST</b>	<b>F8-7718</b>		H=118
Top Strut Mounting	1.8 TFSI, 2.0 TDI, 2.0 TFSI, 2.0 TFSI quattro, 2.7 TDI, 3.0 TDI, 3.0 TDI quattro, 3.2 FSI, 3.2 FSI quattro, S5 quattro	not for PR: 1BL;	<b>F8-7742</b>		
Protective Cap/Bellow, shock absorber	1.8 TFSI, 2.0 TDI, 2.0 TDI quattro, 2.0 TFSI, 2.0 TFSI quattro, 2.7 TDI, 3.0 TDI, 3.0 TDI quattro, 3.0 TFSI quattro, 3.2 FSI, 3.2 FSI quattro, RS 5 quattro, S5 quattro	for OE: 1BL;	<b>F8-7814</b>		
Rubber Buffer, suspension	1.8 TFSI, 2.0 TDI, 2.0 TDI quattro, 2.0 TFSI, 2.0 TFSI quattro, 2.7 TDI, 3.0 TDI, 3.0 TDI quattro, 3.0 TFSI quattro, 3.2 FSI, 3.2 FSI quattro, RS 5 quattro, S5 quattro	for OE: 1BL;	<b>F8-7840</b>		
Rubber Buffer, suspension	1.8 TFSI, 2.0 TDI, 2.0 TDI quattro, 2.0 TFSI, 2.0 TFSI quattro, 2.7 TDI, 3.0 TDI, 3.0 TDI quattro, 3.0 TFSI quattro, 3.2 FSI, 3.2 FSI quattro, RS 5 quattro, S5 quattro	for OE: 1BL;	<b>F8-7841</b>		H=77



**Article Description****Article Nr.****Fitting Position**

<b>A5 Convertible (8F7)</b>			<b>03/2009 →</b>		
Belt Pulley, crankshaft	1.8 TFSI, 2.0 TFSI, 2.0 TFSI quattro	Number of Ribs: 5; Parameter: 6PK	<b>F8-7880</b>		D=143
Control Arm-/Trailing Arm Bush	2.0 TDI, 2.0 TFSI, 2.7 TDI, 3.0 TDI quattro, 3.2 FSI, S5 quattro		<b>F8-7941</b>		
Control Arm-/Trailing Arm Bush	1.8 TFSI, 2.0 TDI, 2.0 TDI quattro, 3.0 TDI, 3.0 TDI quattro, 3.0 TFSI quattro		<b>F8-7999</b>		H=80; d=13; D=75
Control Arm-/Trailing Arm Bush	1.8 TFSI, 2.0 TDI, 2.0 TFSI, 2.0 TFSI quattro, 2.7 TDI, 3.0 TDI quattro, 3.2 FSI, 3.2 FSI quattro, S5 quattro	05/2010 →; ☆, <b>ST</b>	<b>F8-7999</b>		H=80; d=13; D=75
Control Arm-/Trailing Arm Bush	1.8 TFSI, 2.0 TDI, 2.0 TFSI, 2.0 TFSI quattro, 2.7 TDI, 3.0 TDI quattro, 3.2 FSI, 3.2 FSI quattro, S5 quattro	☆	<b>F8-7999</b>		H=80; d=13; D=75
Control Arm-/Trailing Arm Bush	1.8 TFSI, 2.0 TDI, 2.0 TDI quattro, 2.0 TFSI, 2.0 TFSI quattro, 2.7 TDI, 3.0 TDI, 3.0 TDI quattro, 3.0 TFSI quattro, 3.2 FSI, 3.2 FSI quattro, S5 quattro		<b>F8-8073</b>		
<b>A5 Sportback (8TA)</b>			<b>09/2009 →</b>		
Alternator Freewheel Clutch	2.0 TDI, 2.0 TDI quattro		<b>F5-1085</b>		
Alternator Freewheel Clutch	2.7 TDI, 3.0 TDI, 3.0 TDI quattro		<b>F5-1140</b>		
Alternator Freewheel Clutch	3.0 TFSI quattro, 3.2 FSI quattro, S5 quattro		<b>F5-1146</b>		
Belt Pulley, crankshaft	2.0 TDI	Number of Ribs: 5; Parameter: 6PK	<b>F8-6396</b>		H=41.6; d=30; Mounting points diam.[mm]=7, 8.6; D=139.7
Belt Pulley, crankshaft	2.0 TDI	CGLD; Number of Ribs: 5; Parameter: 6PK	<b>F8-6572</b>		
Belt Pulley, crankshaft	2.0 TDI	CJCA, CMFA; Number of Ribs: 5; Parameter: 6PK	<b>F8-6572</b>		
Belt Pulley, crankshaft	2.0 TDI	CJCB; Number of Ribs: 5; Parameter: 6PK	<b>F8-6572</b>		
Belt Pulley, crankshaft	2.0 TDI, 2.0 TDI quattro	Number of Ribs: 5; Parameter: 6PK	<b>F8-6572</b>		
Control Arm-/Trailing Arm Bush	1.8 TFSI, 2.0 TDI, 2.0 TDI quattro, 2.0 TFSI, 2.0 TFSI quattro, 2.7 TDI, 3.0 TDI, 3.0 TDI quattro, 3.0 TFSI quattro, 3.2 FSI quattro, S5 quattro		<b>F8-6582</b>		
Control Arm-/Trailing Arm Bush	1.8 TFSI, 2.0 TDI, 2.0 TDI quattro, 2.0 TFSI, 2.0 TFSI quattro, 2.7 TDI, 3.0 TDI, 3.0 TDI quattro, 3.0 TFSI quattro, 3.2 FSI quattro, S5 quattro		<b>F8-6784</b>		H=45; d=12.2; D=43.8
Top Strut Mounting	1.8 TFSI, 2.0 TDI, 2.0 TDI quattro, 2.0 TFSI, 2.0 TFSI quattro, 2.7 TDI, 3.0 TDI quattro, 3.2 FSI quattro, S5 quattro		<b>F8-7452</b>		
Protective Cap/Bellow, shock absorber	1.8 TFSI, 2.0 TDI, 2.0 TDI quattro, 2.0 TFSI, 2.0 TFSI quattro, 2.7 TDI, 3.0 TDI, 3.0 TDI quattro, 3.0 TFSI quattro, 3.2 FSI quattro, S5 quattro		<b>F8-7681</b>		H=100
Protective Cap/Bellow, shock absorber	1.8 TFSI, 2.0 TDI, 2.0 TDI quattro, 2.0 TFSI, 2.0 TFSI quattro, 2.7 TDI, 3.0 TDI, 3.0 TDI quattro, 3.0 TFSI quattro, 3.2 FSI quattro, S5 quattro	for OE: 1BA, 1BD, 1BE, 1BV; <b>SP</b> , <b>ST</b>	<b>F8-7682</b>		H=160
Rubber Buffer, suspension	1.8 TFSI, 2.0 TDI, 2.0 TDI quattro, 2.0 TFSI, 2.0 TFSI quattro, 2.7 TDI, 3.0 TDI, 3.0 TDI quattro, 3.2 FSI quattro, S5 quattro	for OE: 1BB; <b>Δ</b>	<b>F8-7704</b>		H=145

<b>F5-1085</b>	<b>F5-1140</b>	<b>F5-1146</b>	<b>F8-6396</b>	<b>F8-6572</b>	<b>F8-6582</b>	<b>F8-6784</b>
Ref.Nr.: 045903119A	Ref.Nr.: 059903119L	Ref.Nr.: 06E903119Q	Ref.Nr.: 03G105243	Ref.Nr.: 038105243L	Ref.Nr.: 8K0407182A	Ref.Nr.: 4E0407181B
<b>F8-7452</b>	<b>F8-7681</b>	<b>F8-7682</b>	<b>F8-7704</b>	<b>F8-7715</b>	<b>F8-7880</b>	<b>F8-7941</b>
Ref.Nr.: 8K0513353D	Ref.Nr.: 8K0412137A	Ref.Nr.: 8E0512137E	Ref.Nr.: 8K0512131H	Ref.Nr.: 8K0412131E	Ref.Nr.: 06H105243F	Ref.Nr.: 8K0407183A
<b>F8-7999</b>	<b>F8-8073</b>					
Ref.Nr.: 8K0407183D	Ref.Nr.: 8K0501530N					

Article Description



Article Nr.

Fitting Position



### A5 Sportback (8TA)

09/2009 →

Rubber Buffer, suspension	1.8 TFSI, 2.0 TDI, 2.0 TDI quattro, 2.0 TFSI, 2.0 TFSI quattro, 2.7 TDI, 3.0 TDI, 3.0 TDI quattro, 3.0 TFSI quattro, 3.2 FSI quattro, S5 quattro	for OE: 1BB;	<b>F8-7715</b>		H=81
Rubber Buffer, suspension	1.8 TFSI, 2.0 TDI, 2.0 TDI quattro, 2.0 TFSI, 2.0 TFSI quattro, 2.7 TDI, 3.0 TDI, 3.0 TDI quattro, 3.0 TFSI quattro, 3.2 FSI quattro, S5 quattro	for OE: 1BA, 1BD, 1BE;	<b>F8-7716</b>		H=72
Rubber Buffer, suspension	1.8 TFSI, 2.0 TDI, 2.0 TDI quattro, 2.0 TFSI, 2.0 TFSI quattro, 2.7 TDI, 3.0 TDI, 3.0 TDI quattro, 3.0 TFSI quattro, 3.2 FSI quattro, S5 quattro	for OE: 1BV;	<b>F8-7717</b>		H=66
Rubber Buffer, suspension	1.8 TFSI, 2.0 TDI, 2.0 TDI quattro, 2.0 TFSI, 2.0 TFSI quattro, 2.7 TDI, 3.0 TDI, 3.0 TDI quattro, 3.0 TFSI quattro, 3.2 FSI quattro, S5 quattro	for OE: 1BA, 1BD, 1BE, 1BV;	<b>F8-7718</b>		H=118
Rubber Buffer, suspension	1.8 TFSI	for OE: 1BL;	<b>F8-7719</b>		H=110
Top Strut Mounting	1.8 TFSI, 2.0 TDI, 2.0 TDI quattro, 2.0 TFSI, 2.0 TFSI quattro, 2.7 TDI, 3.0 TDI, 3.0 TDI quattro, 3.2 FSI quattro, S5 quattro	not for PR: 1BL;	<b>F8-7742</b>		
Protective Cap/Bellow, shock absorber	1.8 TFSI, 2.0 TDI, 2.0 TDI quattro, 2.0 TFSI, 2.0 TFSI quattro, 2.7 TDI, 3.0 TDI, 3.0 TDI quattro, 3.0 TFSI quattro, 3.2 FSI quattro	for OE: 1BB;	<b>F8-7802</b>		H=156
Protective Cap/Bellow, shock absorber	1.8 TFSI, 2.0 TDI, 2.0 TDI quattro, 2.0 TFSI, 2.0 TFSI quattro, 2.7 TDI, 3.0 TDI, 3.0 TDI quattro, 3.0 TFSI quattro, 3.2 FSI quattro	for OE: 1BB;	<b>F8-7813</b>		H=167
Protective Cap/Bellow, shock absorber	1.8 TFSI, 2.0 TDI, 2.0 TDI quattro, 2.0 TFSI, 2.0 TFSI quattro, 2.7 TDI, 3.0 TDI, 3.0 TDI quattro, 3.0 TFSI quattro, 3.2 FSI quattro, S5 quattro	for OE: 1BL;	<b>F8-7814</b>		
Rubber Buffer, suspension	1.8 TFSI, 2.0 TDI, 2.0 TDI quattro, 2.0 TFSI, 2.0 TFSI quattro, 2.7 TDI, 3.0 TDI, 3.0 TDI quattro, 3.0 TFSI quattro, 3.2 FSI quattro, S5 quattro	for OE: 1BL;	<b>F8-7840</b>		
Rubber Buffer, suspension	1.8 TFSI, 2.0 TDI, 2.0 TDI quattro, 2.0 TFSI, 2.0 TFSI quattro, 2.7 TDI, 3.0 TDI, 3.0 TDI quattro, 3.0 TFSI quattro, 3.2 FSI quattro, S5 quattro	for OE: 1BL;	<b>F8-7841</b>		H=77
Belt Pulley, crankshaft	1.8 TFSI, 2.0 TFSI, 2.0 TFSI quattro	Number of Ribs: 5; Parameter: 6PK	<b>F8-7880</b>		D=143
Control Arm-/Trailing Arm Bush	1.8 TFSI, 2.0 TDI, 2.0 TDI quattro, 2.0 TFSI, 2.0 TFSI quattro, 2.7 TDI, 3.0 TDI, 3.0 TDI quattro, 3.0 TFSI quattro, 3.2 FSI quattro, S5 quattro		<b>F8-7999</b>		H=80; d=13; D=75
Control Arm-/Trailing Arm Bush	1.8 TFSI, 2.0 TDI, 2.0 TDI quattro, 2.0 TFSI, 2.0 TFSI quattro, 2.7 TDI, 3.0 TDI, 3.0 TDI quattro, 3.2 FSI quattro, S5 quattro		<b>F8-8073</b>		

### A6 (4A, C4)

06/1994 → 10/1997

Dust Cover Kit, shock absorber	1.8, 1.9 TDI, 2.0, 2.0 16V, 2.3, 2.5 TDI, 2.6, 2.8		<b>AK-735020</b>		
Dust Cover Kit, shock absorber	1.8, 1.9 TDI, 2.0, 2.0 16V, 2.3, 2.5 TDI, 2.6, 2.8		<b>AK-735125</b>		
Control Arm-/Trailing Arm Bush	1.8, 1.8 quattro, 1.9 TDI, 2.0, 2.0 16V, 2.0 16V quattro, 2.3, 2.3 quattro, 2.5 TDI, 2.5 TDI quattro, 2.6, 2.6 quattro, 2.8, 2.8 quattro, S6 4.2 quattro, S6 Turbo quattro		<b>F8-1024</b>		H1=21; H2=25; d=16; D=63

<b>AK-735020</b>	<b>AK-735125</b>	<b>F8-1024</b>	<b>F8-3003</b>	<b>F8-7715</b>	<b>F8-7716</b>	<b>F8-7717</b>
Ref.Nr.: <b>AK-735020</b>	Ref.Nr.: <b>4A0512129</b>	Ref.Nr.: <b>4A0407181A</b>	Ref.Nr.: <b>4A0399419E</b>	Ref.Nr.: <b>8K0412131E</b>	Ref.Nr.: <b>8K0412131F</b>	Ref.Nr.: <b>8K0412131G</b>
<b>F8-7718</b>	<b>F8-7719</b>	<b>F8-7742</b>	<b>F8-7802</b>	<b>F8-7813</b>	<b>F8-7814</b>	<b>F8-7840</b>
Ref.Nr.: <b>8K0512131B</b>	Ref.Nr.: <b>8K0512131D</b>	Ref.Nr.: <b>8K0412377A</b>	Ref.Nr.: <b>4B0512137B</b>	Ref.Nr.: <b>4G0512137A</b>	Ref.Nr.: <b>8K0512137A</b>	Ref.Nr.: <b>8F0512131E</b>
<b>F8-7841</b>	<b>F8-7880</b>	<b>F8-7999</b>	<b>F8-8073</b>			
Ref.Nr.: <b>8F0412131</b>	Ref.Nr.: <b>06H105243F</b>	Ref.Nr.: <b>8K0407183D</b>	Ref.Nr.: <b>8K0501530N</b>			

**Article Description****Article Nr.****Fitting Position**

<b>A6 (4A, C4)</b>		<b>06/1994 → 10/1997</b>	
Mounting, automatic transmission	2.3, 2.3 quattro, 2.5 TDI, 2.5 TDI quattro, 2.6, 2.6 quattro, 2.8, 2.8 quattro, S6 Turbo quattro		<b>F8-3003</b>
Mounting, automatic transmission	2.3, 2.3 quattro, 2.5 TDI, 2.5 TDI quattro, 2.6, 2.6 quattro, 2.8, 2.8 quattro, S6 Turbo quattro		<b>F8-3004</b>
Stabiliser Mounting	1.8, 1.8 quattro, 1.9 TDI, 2.0, 2.0 16V, 2.0 16V quattro, 2.3, 2.3 quattro, 2.5 TDI, 2.5 TDI quattro, 2.6, 2.6 quattro, 2.8, 2.8 quattro, S6 4.2 quattro, S6 Plus quattro, S6 Turbo quattro	for OE: 4A0411327A; ;	<b>F8-3006</b>
Stabiliser Mounting	2.6		<b>F8-3006</b>
Anti-Friction Bearing	All Models		<b>F8-3008</b>
Top Strut Mounting	All Models		<b>F8-3009</b>
Top Strut Mounting	1.8 quattro, 2.0 16V quattro, 2.3 quattro, 2.5 TDI quattro, 2.6 quattro, 2.8 quattro, S6 4.2 quattro, S6 Plus quattro, S6 Turbo quattro		<b>F8-3010</b>
Top Strut Mounting	1.8, 1.9 TDI, 2.0, 2.0 16V, 2.3, 2.4, 2.5 TDI, 2.6, 2.8		<b>F8-3010</b>
Mounting, automatic transmission	1.8, 1.9 TDI, 2.0, 2.0 16V, 2.8 quattro		<b>F8-3056</b>
Engine Mounting	2.0 16V		<b>F8-4019</b>
Engine Mounting	2.0 16V quattro, 2.3, 2.3 quattro, 2.5 TDI, S6 Turbo quattro		<b>F8-4019</b>
Rubber Buffer, engine mounting	1.8, 1.8 quattro, 1.9 TDI		<b>F8-4020</b>
Engine Mounting	2.3, 2.3 quattro		<b>F8-4021</b>
Engine Mounting	S6 Turbo quattro	01/1996 →;	<b>F8-4021</b>
Rubber Buffer, silencer	2.3, 2.6		<b>F8-4026</b>
Mounting, automatic transmission	1.8 quattro, 2.0 16V quattro, 2.3		<b>F8-4029</b>
Mounting, automatic transmission	1.8, 1.9 TDI, 2.0, 2.0 16V, 2.5 TDI		<b>F8-4029</b>
Protective Cap/Bellow, shock absorber	1.8, 1.8 quattro, 1.9 TDI, 2.0, 2.0 16V, 2.0 16V quattro, 2.3, 2.3 quattro, 2.5 TDI, 2.5 TDI quattro, 2.6, 2.6 quattro, 2.8, 2.8 quattro, S6 4.2 quattro, S6 Plus quattro, S6 Turbo quattro		<b>F8-4066</b>
Bellow, steering	1.8, 1.8 quattro, 1.9 TDI, 2.0, 2.0 16V, 2.0 16V quattro, 2.3, 2.3 quattro, 2.5 TDI, 2.5 TDI quattro, 2.6, 2.6 quattro, 2.8, 2.8 quattro, S6 4.2 quattro, S6 Plus quattro, S6 Turbo quattro		<b>F8-4070</b>
Belt Pulley, crankshaft	2.5 TDI, 2.5 TDI quattro		<b>F8-5202</b>
Belt Pulley, crankshaft	2.5 TDI, 2.5 TDI quattro	with fastening material	<b>F8-5202K1</b>
Control Arm-/Trailing Arm Bush	1.8 quattro, 2.0 16V quattro, 2.3 quattro, 2.5 TDI quattro, 2.6 quattro, 2.8 quattro, S6 4.2 quattro, S6 Plus quattro, S6 Turbo quattro		<b>F8-5306</b>
Mounting, axle beam	1.8, 1.9 TDI, 2.0, 2.0 16V, 2.3, 2.5 TDI		<b>F8-5342</b>



**Article Description**

**Article Nr.**
**Fitting Position**

<b>A6 (4A, C4)</b>		<b>06/1994 → 10/1997</b>	
Suspension, panhard rod	1.8, 1.9 TDI, 2.0, 2.0 16V, 2.3, 2.5 TDI, 2.6, 2.8		<b>F8-5344</b>
Mounting, radiator	1.8, 1.8 quattro, 1.9 TDI, 2.0, 2.0 16V, 2.0 16V quattro, 2.3, 2.3 quattro, 2.5 TDI, 2.5 TDI quattro, 2.6, 2.6 quattro, 2.8, 2.8 quattro, S6 4.2 quattro, S6 Plus quattro, S6 Turbo quattro		<b>F8-5526</b>
Mounting, axle beam	1.8 quattro, 2.0 16V quattro, 2.3 quattro, 2.5 TDI quattro, 2.6 quattro, 2.8 quattro, S6 4.2 quattro, S6 Turbo quattro		<b>F8-5541</b>
Mounting, axle bracket	1.8, 1.8 quattro, 2.0, 2.0 16V quattro, 2.4, 2.5 TDI quattro, 2.6, 2.8, 2.8 quattro, S6 4.2 quattro, S6 Plus quattro		<b>F8-5543</b>
Mounting, axle bracket	1.9 TDI, 2.0, 2.0 16V, 2.3, 2.3 quattro, 2.5 TDI, 2.6, 2.8	01/1995 →	<b>F8-5543</b>
Mounting, axle bracket	2.6 quattro, S6 Turbo quattro	ch.4A-M-000001→	<b>F8-5543</b>
Engine Mounting	1.8 quattro	Transmission Nr: CBL, CYT, DET, DPG, DPH;	<b>F8-5544</b>
Engine Mounting	2.0 16V quattro, 2.3 quattro, 2.5 TDI quattro, 2.6 quattro, 2.8 quattro	Transmission Nr: CBL, CYT, DET, DPG, DPH, DPJ	<b>F8-5544</b>
Engine Mounting	1.8, 1.8 quattro, 1.9 TDI, 2.0, 2.0 16V, 2.0 16V quattro		<b>F8-5545</b>
Engine Mounting	2.6, 2.6 quattro, 2.8, 2.8 quattro		<b>F8-5546</b>
Engine Mounting	2.6, 2.6 quattro, 2.8, 2.8 quattro		<b>F8-5547</b>
Mounting, radiator	1.8, 1.8 quattro, 1.9 TDI, 2.0, 2.0 16V, 2.0 16V quattro, 2.3, 2.3 quattro, 2.5 TDI, 2.5 TDI quattro, 2.6, 2.6 quattro, 2.8, 2.8 quattro, S6 4.2 quattro, S6 Plus quattro, S6 Turbo quattro		<b>F8-5548</b>
Belt Pulley, crankshaft	1.9 TDI	Number of Ribs: 5; Parameter: 6PK	<b>F8-5649</b>
Rubber Buffer, suspension	1.8, 1.8 quattro, 1.9 TDI, 2.0, 2.0 16V, 2.0 16V quattro, 2.3, 2.3 quattro, 2.4, 2.5 TDI, 2.5 TDI quattro, 2.6, 2.6 quattro, 2.8, 2.8 quattro		<b>F8-5763</b>
Control Arm-/Trailing Arm Bush	1.8 quattro, 2.0 16V quattro, 2.3 quattro, 2.5 TDI quattro, 2.6 quattro, 2.8 quattro, S6 4.2 quattro, S6 Plus quattro, S6 Turbo quattro		<b>F8-5778</b>
Engine Mounting	1.9 TDI	Green	<b>F8-6747</b>
Top Strut Mounting	All Models		<b>F8-7453</b>
Control Arm-/Trailing Arm Bush	1.8, 1.8 quattro, 1.9 TDI, 2.0, 2.0 16V, 2.0 16V quattro, 2.3, 2.3 quattro, 2.5 TDI, 2.5 TDI quattro, 2.6, 2.6 quattro, 2.8, 2.8 quattro		<b>G9-617</b>
Control Arm-/Trailing Arm Bush	S6 4.2 quattro, S6 Turbo quattro	01/1996 →	<b>G9-617</b>
<b>A6 Avant (4A, C4)</b>		<b>06/1994 → 12/1997</b>	
Dust Cover Kit, shock absorber	1.8, 1.9 TDI, 2.0, 2.0 16V, 2.3, 2.5 TDI, 2.6, 2.8		<b>AK-735020</b>
Dust Cover Kit, shock absorber	1.8, 1.9 TDI, 2.0, 2.0 16V, 2.3, 2.5 TDI, 2.6, 2.8		<b>AK-735125</b>

<b>AK-735020</b>	<b>AK-735125</b>	<b>F8-1024</b>	<b>F8-5344</b>	<b>F8-5526</b>	<b>F8-5541</b>	<b>F8-5543</b>
Ref.Nr.: <b>AK-735020</b>	Ref.Nr.: <b>4A0512129</b>	Ref.Nr.: <b>4A0407181A</b>	Ref.Nr.: <b>431505172</b>	Ref.Nr.: <b>8D0121275</b>	Ref.Nr.: <b>4D0511523C</b>	Ref.Nr.: <b>4A0399415</b>
<b>F8-5544</b>	<b>F8-5545</b>	<b>F8-5546</b>	<b>F8-5547</b>	<b>F8-5548</b>	<b>F8-5649</b>	<b>F8-5763</b>
Ref.Nr.: <b>4A0399151C</b>	Ref.Nr.: <b>4A0199379C</b>	Ref.Nr.: <b>4A0199352A</b>	Ref.Nr.: <b>4A0199351B</b>	Ref.Nr.: <b>4A0018977</b>	Ref.Nr.: <b>028105243T</b>	Ref.Nr.: <b>4A0412131</b>
<b>F8-5778</b>	<b>F8-6747</b>	<b>F8-7453</b>	<b>G9-617</b>			
Ref.Nr.: <b>4A0511249</b>	Ref.Nr.: <b>4A0199379G</b>	Ref.Nr.: <b>4A0412377A</b>	Ref.Nr.: <b>4A0407183D</b>			

**Article Description****Article Nr.****Fitting Position**

<b>A6 Avant (4A, C4)</b>		<b>06/1994 → 12/1997</b>		
Control Arm-/Trailing Arm Bush	1.8, 1.8 quattro, 1.9 TDI, 2.0, 2.0 16V, 2.0 16V quattro, 2.3, 2.3 quattro, 2.5 TDI, 2.5 TDI quattro, 2.6, 2.6 quattro, 2.8, 2.8 quattro, S6 4.2 quattro, S6 Plus quattro, S6 Turbo quattro		<b>F8-1024</b>	H1=21; H2=25; d=16; D=63
Mounting, automatic transmission	2.3, 2.3 quattro, 2.5 TDI, 2.5 TDI quattro, 2.6, 2.6 quattro, 2.8, 2.8 quattro, S6 Turbo quattro		<b>F8-3003</b>	H=69; d=11; D=65
Mounting, automatic transmission	2.3, 2.3 quattro, 2.5 TDI, 2.5 TDI quattro, 2.6, 2.6 quattro, 2.8, 2.8 quattro, S6 Turbo quattro		<b>F8-3004</b>	H=69; d=11; D=65
Stabiliser Mounting	1.8, 1.8 quattro, 1.9 TDI, 2.0, 2.0 16V, 2.0 16V quattro, 2.3, 2.3 quattro, 2.5 TDI, 2.5 TDI quattro, 2.6, 2.6 quattro, 2.8, 2.8 quattro, S6 4.2 quattro, S6 Plus quattro, S6 Turbo quattro	for OE: 4A0411327A;	<b>F8-3006</b>	H=41; d=24; Thick. [mm]=66
Stabiliser Mounting	2.6		<b>F8-3006</b>	H=41; d=24; Thick. [mm]=66
Anti-Friction Bearing	All Models		<b>F8-3008</b>	H=15; d=91; D=112
Top Strut Mounting	All Models		<b>F8-3009</b>	H=41; d=17; D=73
Top Strut Mounting	1.8 quattro, 2.0 16V quattro, 2.3 quattro, 2.5 TDI quattro, 2.6 quattro, 2.8 quattro, S6 4.2 quattro, S6 Plus quattro, S6 Turbo quattro		<b>F8-3010</b>	H=33; d=10; D=79
Top Strut Mounting	1.8, 1.9 TDI, 2.0, 2.0 16V, 2.3, 2.4, 2.5 TDI, 2.6, 2.8		<b>F8-3010</b>	H=33; d=10; D=79
Mounting, automatic transmission	1.8, 1.9 TDI, 2.0, 2.0 16V, 2.8 quattro		<b>F8-3056</b>	H=70; d=11; D=65
Engine Mounting	2.0 16V		<b>F8-4019</b>	H=47; d=26; D1=48; D2=67
Engine Mounting	2.0 16V quattro, 2.3, 2.3 quattro, 2.5 TDI, S6 Turbo quattro		<b>F8-4019</b>	H=47; d=26; D1=48; D2=67
Rubber Buffer, engine mounting	1.8, 1.8 quattro, 1.9 TDI		<b>F8-4020</b>	H=47; d=26; D1=47; D2=70
Engine Mounting	2.3, 2.3 quattro		<b>F8-4021</b>	H=96; D=114; $\tau$ [mm]=146
Engine Mounting	S6 Turbo quattro	01/1996 →;	<b>F8-4021</b>	H=96; D=114; $\tau$ [mm]=146
Mounting, automatic transmission	1.8, 1.8 quattro, 1.9 TDI, 2.0, 2.0 16V, 2.0 16V quattro, 2.5 TDI		<b>F8-4029</b>	H=125; d=9; Thick. [mm]=55; W=96
Mounting, automatic transmission	2.3, 2.5 TDI		<b>F8-4029</b>	H=125; d=9; Thick. [mm]=55; W=96
Protective Cap/Bellow, shock absorber	1.8, 1.8 quattro, 1.9 TDI, 2.0, 2.0 16V, 2.0 16V quattro, 2.3, 2.3 quattro, 2.5 TDI, 2.5 TDI quattro, 2.6, 2.6 quattro, 2.8, 2.8 quattro, S6 4.2 quattro, S6 Plus quattro, S6 Turbo quattro		<b>F8-4066</b>	H=105; D1=69; D2=105
Bellow, steering	1.8, 1.8 quattro, 1.9 TDI, 2.0, 2.0 16V, 2.0 16V quattro, 2.3, 2.3 quattro, 2.5 TDI, 2.5 TDI quattro, 2.6, 2.6 quattro, 2.8, 2.8 quattro, S6 4.2 quattro, S6 Plus quattro, S6 Turbo quattro		<b>F8-4070</b>	L=530; D1=40; D2=48
Belt Pulley, crankshaft	2.5 TDI, 2.5 TDI quattro		<b>F8-5202</b>	H=57.6; d=18.55; D=188
Belt Pulley, crankshaft	2.5 TDI, 2.5 TDI quattro	with fastening material	<b>F8-5202K1</b>	H=57.6; d=18.55; D=188

<b>F8-1024</b>	<b>F8-3003</b>	<b>F8-3004</b>	<b>F8-3006</b>	<b>F8-3008</b>	<b>F8-3009</b>	<b>F8-3010</b>
Ref.Nr.: 4A0407181A	Ref.Nr.: 4A0399419E	Ref.Nr.: 4A0399420E	Ref.Nr.: 4A0411327A	Ref.Nr.: 4A0412249	Ref.Nr.: 4A0412377B	Ref.Nr.: 443512331
<b>F8-3056</b>	<b>F8-4019</b>	<b>F8-4020</b>	<b>F8-4021</b>	<b>F8-4029</b>	<b>F8-4066</b>	<b>F8-4070</b>
Ref.Nr.: 4A0399420	Ref.Nr.: 893199339	Ref.Nr.: 893199339D	Ref.Nr.: 443199379E	Ref.Nr.: 4A0399151D	Ref.Nr.: 431412175D	Ref.Nr.: 431419831
<b>F8-5202</b>	<b>F8-5202K1</b>	<b>F8-5306</b>				
Ref.Nr.: 074105251T	Ref.Nr.: 74105251N	Ref.Nr.: 4A0511247B				

Article Description



Article Nr.

Fitting Position



### A6 Avant (4A, C4)

06/1994 → 12/1997

Control Arm-/Trailing Arm Bush	1.8 quattro, 2.0 16V quattro, 2.3 quattro, 2.5 TDI quattro, 2.6 quattro, 2.8 quattro, S6 4.2 quattro, S6 Plus quattro, S6 Turbo quattro		F8-5306		d=14; D=48; W=25
Mounting, axle beam	1.8, 1.9 TDI, 2.0, 2.0 16V, 2.3, 2.5 TDI		F8-5342		
Suspension, panhard rod	1.8, 1.9 TDI, 2.0, 2.0 16V, 2.3, 2.5 TDI, 2.6, 2.8		F8-5344		d=12.2
Mounting, radiator	All Models		F8-5526		d=15; D=40; Thick. [mm]=25
Mounting, axle beam	1.8 quattro, 2.0 16V quattro, 2.3 quattro, 2.5 TDI quattro, 2.6 quattro, 2.8 quattro, S6 4.2 quattro, S6 Turbo quattro		F8-5541		d=12; D=58; W=35.8, 58
Mounting, axle bracket	1.8, 1.8 quattro, 2.0, 2.0 16V, 2.3 quattro, 2.4, 2.5 TDI quattro, 2.6, 2.6 quattro, 2.8, 2.8 quattro, S6 4.2 quattro, S6 Plus quattro, S6 Turbo quattro		F8-5543		H=60; D=55
Mounting, axle bracket	1.9 TDI, 2.3, 2.5 TDI	01/1995 →	F8-5543		H=60; D=55
Mounting, axle bracket	2.0, 2.0 16V quattro, 2.5 TDI, 2.6, 2.8 quattro	ch.4A-M-000001→	F8-5543		H=60; D=55
Engine Mounting	1.8 quattro, 2.0 16V quattro, 2.3 quattro, 2.5 TDI quattro, 2.6 quattro, 2.8 quattro	Transmission Nr: CBL, CYT, DET, DPG, DPH, DPJ	F8-5544		
Engine Mounting	1.8, 1.8 quattro, 1.9 TDI, 2.0, 2.0 16V, 2.0 16V quattro		F8-5545		
Engine Mounting	2.6, 2.6 quattro, 2.8, 2.8 quattro		F8-5546		
Engine Mounting	2.6, 2.6 quattro, 2.8, 2.8 quattro		F8-5547		
Mounting, radiator	All Models		F8-5548		
Belt Pulley, crankshaft	1.9 TDI	Number of Ribs: 5; Parameter: 6PK	F8-5649		H=31.5; d=30.02; Mounting points diam.[mm]=8.5; D1=161.5; D2=160.5
Rubber Buffer, suspension	1.8, 1.8 quattro, 1.9 TDI, 2.0, 2.0 16V, 2.0 16V quattro, 2.3, 2.3 quattro, 2.4, 2.5 TDI, 2.5 TDI quattro, 2.6, 2.6 quattro, 2.8, 2.8 quattro		F8-5763		H=90
Control Arm-/Trailing Arm Bush	1.8 quattro, 2.0 16V quattro, 2.3 quattro, 2.5 TDI quattro, 2.6 quattro, 2.8 quattro, S6 4.2 quattro, S6 Plus quattro, S6 Turbo quattro		F8-5778		H=25; d=14; D=48
Engine Mounting	1.9 TDI	Green	F8-6747		
Top Strut Mounting	All Models		F8-7453		
Control Arm-/Trailing Arm Bush	1.8, 1.8 quattro, 1.9 TDI, 2.0, 2.0 16V, 2.0 16V quattro, 2.3, 2.3 quattro, 2.5 TDI, 2.5 TDI quattro, 2.6, 2.6 quattro, 2.8, 2.8 quattro, S6 Plus quattro		G9-617		H=32; d=15; D=55
Control Arm-/Trailing Arm Bush	S6 4.2 quattro, S6 Turbo quattro	01/1996 →	G9-617		H=32; d=15; D=55

### A6 (4B2, C5)

01/1997 → 01/2005

Dust Cover Kit, shock absorber	1.8, 1.8 T, 1.8 T quattro, 1.9 TDI, 2.0, 2.4, 2.4 quattro, 2.5 TDI, 2.5 TDI quattro, 2.7 T, 2.7 T quattro, 2.8, 2.8 quattro, 3.0, 3.0 quattro		AK-735101		
Dust Cover Kit, shock absorber	1.8, 1.8 T, 1.9 TDI, 2.0, 2.4, 2.5 TDI, 2.7 T, 2.8, 3.0		AK-735127		
Alternator Freewheel Clutch	1.8, 1.8 T, 1.8 T quattro		F5-1002		

<b>AK-735101</b>	<b>AK-735127</b>	<b>F5-1002</b>	<b>F5-1006</b>	<b>F8-5306</b>	<b>F8-5342</b>	<b>F8-5344</b>
Ref.Nr.: 4D0412137C	Ref.Nr.:	Ref.Nr.: 038903119P	Ref.Nr.: 038903119M	Ref.Nr.: 4A0511247B	Ref.Nr.: 4A0511247	Ref.Nr.: 431505172
<b>F8-5526</b>	<b>F8-5541</b>	<b>F8-5543</b>	<b>F8-5544</b>	<b>F8-5545</b>	<b>F8-5546</b>	<b>F8-5547</b>
Ref.Nr.: 8D0121275	Ref.Nr.: 4D0511523C	Ref.Nr.: 4A0399415	Ref.Nr.: 4A0399151C	Ref.Nr.: 4A0199379C	Ref.Nr.: 4A0199352A	Ref.Nr.: 4A0199351B
<b>F8-5548</b>	<b>F8-5649</b>	<b>F8-5763</b>	<b>F8-5778</b>	<b>F8-6747</b>	<b>F8-7453</b>	<b>G9-617</b>
Ref.Nr.: 4A0018977	Ref.Nr.: 028105243T	Ref.Nr.: 4A0412131	Ref.Nr.: 4A0511249	Ref.Nr.: 4A0199379G	Ref.Nr.: 4A0412377A	Ref.Nr.: 4A0407183D



**Article Description****Article Nr.****Fitting Position**

<b>A6 (4B2, C5)</b>			<b>01/1997 → 01/2005</b>		
Alternator Freewheel Clutch	1.8 T, 1.8 T quattro, 1.9 TDI		<b>F5-1006</b>		
Alternator Freewheel Clutch	1.9 TDI		<b>F5-1008</b>		
Alternator Freewheel Clutch	1.8, 1.8 T, 1.8 T quattro		<b>F5-1012</b>		
Alternator Freewheel Clutch	2.0		<b>F5-1044</b>		
Top Strut Mounting	All Models		<b>F8-3050</b>		H=37; d=12; D1=72; D2=86
Engine Mounting	1.8 T, 1.9 TDI, 2.4		<b>F8-4019</b>		H=47; d=26; D1=48; D2=67
Control Arm-/Trailing Arm Bush	1.8 T, 1.8 T quattro, 2.4, 2.4 quattro, 2.5 TDI, 2.5 TDI quattro, 2.7 T quattro, 2.8 quattro, 3.7, 3.7 quattro, 4.2 quattro, S6 quattro	for OE: 4D0407151E	<b>F8-4044</b>	   	H1=42; H2=50; d=12; D1=22; D2=40
Control Arm-/Trailing Arm Bush	1.8, 1.8 T, 1.9 TDI, 2.4, 2.5 TDI, 2.8	01/1998 →	<b>F8-4044</b>	   	H1=42; H2=50; d=12; D1=22; D2=40
Control Arm-/Trailing Arm Bush	2.7 T		<b>F8-4044</b>	   	H1=42; H2=50; d=12; D1=22; D2=40
Control Arm-/Trailing Arm Bush	1.8 T, 1.8 T quattro, 2.4, 2.4 quattro, 2.5 TDI, 2.5 TDI quattro, 2.7 T quattro, 2.8 quattro, 3.7, 3.7 quattro, 4.2 quattro, S6 quattro	for OE: 4D0407151E	<b>F8-4045</b>	   	H1=31; H2=60; d=12; D=50
Control Arm-/Trailing Arm Bush	1.8, 1.8 T, 1.9 TDI, 2.4, 2.5 TDI, 2.8	01/1998 →	<b>F8-4045</b>	   	H1=31; H2=60; d=12; D=50
Control Arm-/Trailing Arm Bush	1.8, 1.9 TDI, 2.0, 2.4, 2.4 quattro, 2.5 TDI, 2.7, 2.7 quattro, 2.7 T, 2.7 T quattro, 2.8, 2.8 quattro, 3.0, 3.0 quattro		<b>F8-4045</b>	   	H1=31; H2=60; d=12; D=50
Stabiliser Mounting	1.8, 1.8 T, 1.9 TDI, 2.4, 2.5 TDI, 2.7 T, 2.8		<b>F8-5064</b>	 	H=44; d=27
Rubber Buffer, engine mounting	2.5 TDI, 2.5 TDI quattro		<b>F8-5524</b>		d=26; L=47; D=68
Mounting, radiator	1.8, 1.8 T, 1.8 T quattro, 1.9 TDI, 2.0, 2.4, 2.4 quattro, 2.5 TDI, 2.5 TDI quattro, 2.7 T, 2.7 T quattro, 2.8, 2.8 quattro, 3.0, 3.0 quattro, 3.7, 3.7 quattro, 4.2 quattro, RS6 quattro, S6 quattro		<b>F8-5526</b>		d=15; D=40; Thick. [mm]=25
Engine Mounting	1.8, 1.8 T, 1.8 T quattro		<b>F8-5538</b>		
Control Arm-/Trailing Arm Bush	1.8, 1.8 T, 1.8 T quattro, 1.9 TDI, 2.4, 2.4 quattro, 2.5 TDI, 2.5 TDI quattro, 2.8, 2.8 quattro	ch.4B-X-000001→; 08/1998 →	<b>F8-5542</b>	   	H=40; d=10; D=46
Control Arm-/Trailing Arm Bush	1.8, 1.9 TDI, 2.0, 2.4, 2.4 quattro, 2.5 TDI, 2.5 TDI quattro, 2.7 T, 2.7 T quattro, 2.8, 3.0, 3.0 quattro, 3.7, 4.2 quattro, RS6 quattro, S6 quattro		<b>F8-5542</b>	   	H=40; d=10; D=46
Control Arm-/Trailing Arm Bush	2.4 quattro, 2.8 quattro, 3.0 quattro, 3.7 quattro	not for PR: 1BV;	<b>F8-5542</b>	   	H=40; d=10; D=46
Control Arm-/Trailing Arm Bush	2.5 TDI	BAU	<b>F8-5542</b>	   	H=40; d=10; D=46
Control Arm-/Trailing Arm Bush	2.8	ATX	<b>F8-5542</b>	   	H=40; d=10; D=46
Mounting, radiator	1.8, 1.8 T, 1.8 T quattro, 1.9 TDI, 2.0, 2.4, 2.4 quattro, 2.5 TDI, 2.5 TDI quattro, 2.7 T, 2.7 T quattro, 2.8, 2.8 quattro, 3.0, 3.0 quattro, 3.7, 3.7 quattro, 4.2 quattro, RS6 quattro, S6 quattro		<b>F8-5548</b>		

<b>F5-1006</b>	<b>F5-1008</b>	<b>F5-1012</b>	<b>F5-1044</b>	<b>F8-3050</b>	<b>F8-4019</b>	<b>F8-4044</b>
Ref.Nr.: 038903119M	Ref.Nr.: 028903119AN	Ref.Nr.: 058903119C	Ref.Nr.: 06B903119B	Ref.Nr.: 4D0412377D	Ref.Nr.: 893199339	Ref.Nr.: 4D0407181H
<b>F8-4045</b>	<b>F8-5064</b>	<b>F8-5524</b>	<b>F8-5526</b>	<b>F8-5538</b>	<b>F8-5542</b>	<b>F8-5548</b>
Ref.Nr.: 4D0407182E	Ref.Nr.: 4D0411327F	Ref.Nr.: 893199339A	Ref.Nr.: 8D0121275	Ref.Nr.: 8D0199382L	Ref.Nr.: 4B0407515	Ref.Nr.: 4A0018977
<b>F8-5565</b>						
Ref.Nr.: 8D0199379S						

**Article Description**

**Article Nr.**
**Fitting Position**

**A6 (4B2, C5)**

01/1997 → 01/2005

Engine Mounting	1.8, 1.8 T, 1.8 T quattro		<b>F8-5565</b>		
Engine Mounting	2.4, 2.4 quattro, 2.5 TDI, 2.5 TDI quattro, 2.8, 2.8 quattro, 3.0, 3.0 quattro		<b>F8-5567</b>		
Top Strut Mounting	1.8, 1.8 T, 1.9 TDI, 2.0, 2.4, 2.5 TDI, 2.7, 2.7 T, 2.8, 3.0, 3.7		<b>F8-5572</b>		
Mounting, automatic transmission	1.8	ch.4B-1-039836, 4B-Y-062561→;  AQE, ARH;  4-speed	<b>F8-5574</b>		
Mounting, automatic transmission	1.8	ch.4B-Y-062561→	<b>F8-5574</b>		
Mounting, automatic transmission	1.8 T	ch.4B-Y-062561→; 05/2000 →;  AWT; Transmission Type: CVT (Stepless)	<b>F8-5574</b>		
Mounting, automatic transmission	1.8, 1.8 T quattro	ch.4B-Y-062561→; 06/2001 →;  AWT;  4-speed,  5-speed	<b>F8-5574</b>		
Mounting, automatic transmission	1.8, 1.8 T quattro	ch.4B-Y-062561→; 06/2001 →;  AWT;  4-speed,  5-speed	<b>F8-5574</b>		
Mounting, automatic transmission	1.8, 1.9 TDI	ch.4B-2-150001, 4B-Y-062561→; Transmission Type: CVT (Stepless)	<b>F8-5574</b>		
Mounting, automatic transmission	1.9 TDI	ch.4B-1-039836, 4B-Y-062561→;  4-speed	<b>F8-5574</b>		
Mounting, automatic transmission	1.9 TDI	ch.4B-1-039836→	<b>F8-5574</b>		
Mounting, automatic transmission	1.9 TDI	ch.4B-1-039836→;  4-speed	<b>F8-5574</b>		
Mounting, automatic transmission	2.0	Transmission Type: CVT (Stepless)	<b>F8-5574</b>		
Mounting, automatic transmission	S6 quattro		<b>F8-5574</b>		
Mounting, automatic transmission	2.4	ch.→4B-W-065000; ; Transmission Type: CVT (Stepless)	<b>F8-5575</b>		H=72; D=71
Mounting, automatic transmission	2.4	ch.4B-W-056741→; ch.→4B-W-056740;  AML; Transmission Type: DJV	<b>F8-5575</b>		H=72; D=71
Mounting, automatic transmission	2.4	ch.4B-W-065001→; ch.→4B-W-065000;  AGA	<b>F8-5575</b>		H=72; D=71
Mounting, automatic transmission	2.4	ch.4B-W-065001→; ch.→4B-W-065000;  AJG, AMM, APZ; Transmission Type: CVT (Stepless)	<b>F8-5575</b>		H=72; D=71
Mounting, automatic transmission	2.4 quattro	ch.4B-W-056741, 4B-W-065001→; ch.→4B-W-056740, 4B-W-065000	<b>F8-5575</b>		H=72; D=71
Mounting, automatic transmission	2.4 quattro, 2.7 T quattro, 3.0 quattro	ch.→4B-5-050000	<b>F8-5575</b>		H=72; D=71
Mounting, automatic transmission	2.4 quattro, 2.8, 2.8 quattro	ch.4B-W-065001→; ch.→4B-W-065000	<b>F8-5575</b>		H=72; D=71
Mounting, automatic transmission	2.4 quattro, S6 quattro	ch.4B-W-056741→; ch.→4B-W-056740	<b>F8-5575</b>		H=72; D=71

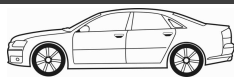

**Article Description****Article Nr.****Fitting Position**

<b>A6 (4B2, C5)</b>			<b>01/1997 → 01/2005</b>		
Mounting, automatic transmission	2.4, 2.5 TDI, 3.0	ch.→4B-5-050000; Transmission Type: CVT (Stepless)	<b>F8-5575</b>		H=72; D=71
Mounting, automatic transmission	2.5 TDI	AKE	<b>F8-5575</b>		H=72; D=71
Mounting, automatic transmission	2.5 TDI quattro	ch.4B-W-065001→; ch.→4B-W-050000, 4B-W-065000; Transmission Type: CVT (Stepless)	<b>F8-5575</b>		H=72; D=71
Mounting, automatic transmission	2.5 TDI quattro	AKE, BAU, BDH	<b>F8-5575</b>		H=72; D=71
Mounting, automatic transmission	2.5 TDI, 2.8		<b>F8-5575</b>		H=72; D=71
Mounting, automatic transmission	2.7 T	Transmission Type: CVT (Stepless)	<b>F8-5575</b>		H=72; D=71
Mounting, automatic transmission	2.7 T quattro	ch.4B-W-065001→; ch.→4B-W-065000;	<b>F8-5575</b>		H=72; D=71
Mounting, automatic transmission	2.8	ch.4B-W-065001→; ch.→4B-W-065000;  ACK, ALG, APR, AQD	<b>F8-5575</b>		H=72; D=71
Mounting, automatic transmission	4.2 quattro	ch.4B-W-056741→; ch.→4B-W-056740;  ARS, ASG	<b>F8-5575</b>		H=72; D=71
Mounting, automatic transmission	2.4, 2.4 quattro, 2.8	ch.→4B-X-100000;	<b>F8-5576</b>		
Mounting, automatic transmission	2.4, 2.4 quattro, 2.7 T quattro, 2.8, 2.8 quattro	ch.→4BX100001	<b>F8-5577</b>		
Mounting, manual transmission	1.8, 1.8 T, 1.8 T quattro		<b>F8-5578</b>		
Engine Mounting	1.9 TDI		<b>F8-5579</b>		
Belt Pulley, crankshaft	2.0		<b>F8-5650</b>		
Belt Pulley, crankshaft	1.9 TDI		<b>F8-5654</b>		
Rubber Buffer, suspension	1.8, 1.8 T, 1.8 T quattro, 1.9 TDI, 2.0, 2.4, 2.4 quattro, 2.5 TDI, 2.5 TDI quattro, 2.7 T, 2.7 T quattro, 2.8, 2.8 quattro, 3.0, 3.0 quattro, 3.7, 3.7 quattro, 4.2 quattro, S6 quattro		<b>F8-5994</b>		H=85
Rubber Buffer, suspension	1.8, 1.8 T, 1.9 TDI, 2.4, 2.5 TDI, 2.7 T, 2.8		<b>F8-6001</b>		H=134
Rubber Buffer, suspension	1.8, 1.8 T, 1.9 TDI, 2.4, 2.5 TDI, 2.7 T, 2.8		<b>F8-6003</b>		H=103.5
Rubber Buffer, suspension	1.8, 1.8 T, 1.8 T quattro, 1.9 TDI, 2.4, 2.4 quattro, 2.5 TDI, 2.5 TDI quattro, 2.7 T, 2.7 T quattro, 2.8, 2.8 quattro		<b>F8-6005</b>		H=134
Rubber Buffer, suspension	1.8, 1.8 T, 1.8 T quattro, 1.9 TDI, 2.0, 2.4, 2.4 quattro, 2.5 TDI, 2.5 TDI quattro, 2.7 T, 2.7 T quattro, 2.8, 2.8 quattro, 3.0, 3.0 quattro, 3.7, 3.7 quattro, 4.2 quattro, S6 quattro		<b>F8-6039</b>		H=77
Spring Cap	All Models		<b>F8-6283</b>		
Repair Kit, suspension strut	1.8, 1.8 T, 1.9 TDI, 2.0, 2.4, 2.5 TDI, 2.7, 2.7 T, 2.8, 3.0, 3.7		<b>F8-6344</b>		
Belt Pulley, crankshaft	1.9 TDI	Number of Ribs: 7	<b>F8-6391</b>		

<b>F8-5575</b>	<b>F8-5576</b>	<b>F8-5577</b>	<b>F8-5578</b>	<b>F8-5579</b>	<b>F8-5650</b>	<b>F8-5654</b>
Ref.Nr.: 8D0399415D	Ref.Nr.: 8D0399151M	Ref.Nr.: 8D0399151J	Ref.Nr.: 8D0399151H	Ref.Nr.: 8D0199382G	Ref.Nr.: 06A105243E	Ref.Nr.: 028105243Q
<b>F8-5994</b>	<b>F8-6001</b>	<b>F8-6003</b>	<b>F8-6005</b>	<b>F8-6039</b>	<b>F8-6283</b>	<b>F8-6344</b>
Ref.Nr.: 8D0412131F	Ref.Nr.: 3B0512131H	Ref.Nr.: 4B0512131B	Ref.Nr.: 4B0512131N	Ref.Nr.: 8D0412131E	Ref.Nr.: 8D0412065E	Ref.Nr.: 8E0513353B
<b>F8-6391</b>	<b>F8-6430</b>					
Ref.Nr.: 038105243F	Ref.Nr.: 4B0501522E					

Article Description



Article Nr.

Fitting Position



A6 (4B2, C5)				01/1997 → 01/2005	
Mounting, axle beam	1.8	AJP, AQE, ARH; Paired article nr: F8-6431	<b>F8-6430</b>		
Mounting, axle beam	1.8 T	AEB, ANB, APU, ARK, AWT; Paired article nr: F8-6431	<b>F8-6430</b>		
Mounting, axle beam	1.8, 1.8 T, 1.9 TDI, 2.0, 2.4, 2.5 TDI, 2.7 T, 2.8, 3.0, 3.7	Paired article nr: F8-6431	<b>F8-6430</b>		
Mounting, axle beam	2.5 TDI	AKE, BAU, BDH; Paired article nr: F8-6431	<b>F8-6430</b>		
Mounting, axle beam	2.8	ATX; Paired article nr: F8-6431	<b>F8-6430</b>		
Mounting, axle beam	1.8	AJP, AQE, ARH; Paired article nr: F8-6430	<b>F8-6431</b>		
Mounting, axle beam	1.8 T	AEB, ANB, APU, ARK, AWT; Paired article nr: F8-6430	<b>F8-6431</b>		
Mounting, axle beam	1.8, 1.8 T, 1.9 TDI, 2.0, 2.4, 2.5 TDI, 2.7 T, 2.8, 3.0, 3.7	Paired article nr: F8-6430	<b>F8-6431</b>		
Mounting, axle beam	2.5 TDI	AKE, BAU, BDH; Paired article nr: F8-6430	<b>F8-6431</b>		
Mounting, axle beam	2.8	ATX; Paired article nr: F8-6430	<b>F8-6431</b>		
Mounting, automatic transmission	1.8, 1.8 T, 1.8 T quattro, 1.9 TDI, 2.0, 2.4, 2.4 quattro, 2.5 TDI, 2.5 TDI quattro, 2.7 T, 2.7 T quattro, 2.8, 2.8 quattro, 3.0, 3.0 quattro, 3.7, 3.7 quattro, 4.2 quattro, RS6 quattro, S6 quattro		<b>F8-6470</b>		
Mounting, automatic transmission	1.8, 1.8 T, 1.9 TDI, 2.0, 2.4, 2.5 TDI, 2.7 T, 2.8, 3.0, 3.7		<b>F8-6471</b>		
Engine Mounting	2.5 TDI, 2.5 TDI quattro		<b>F8-6530</b>		
Rubber Buffer, engine mounting	2.7 T, 2.7 T quattro	ch.→4B-5-050000	<b>F8-6758</b>		
Repair Kit, suspension strut	All Models		<b>F8-7097</b>		
Bellow, steering	2.4, 2.4 quattro, 2.5 TDI, 2.5 TDI quattro, 2.7 T, 2.7 T quattro, 2.8, 2.8 quattro, 3.0, 3.0 quattro	for vehicles with steering damper	<b>F8-7148</b>		H=141; d1=65; d2=65
Rubber Buffer, suspension	1.8, 1.8 T, 1.8 T quattro, 1.9 TDI, 2.0, 2.4, 2.4 quattro, 2.5 TDI, 2.5 TDI quattro, 2.7 T, 2.7 T quattro, 2.8, 2.8 quattro, 3.0, 3.0 quattro, 3.7, 3.7 quattro, 4.2 quattro	for OE: 1BA, 1BG; ;	<b>F8-7577</b>		H=94
Rubber Buffer, engine mounting	2.0, 3.0, 3.0 quattro		<b>F8-7599</b>		
Protective Cap/Bellow, shock absorber	1.8, 1.8 T, 1.8 T quattro, 1.9 TDI, 2.0, 2.4, 2.4 quattro, 2.5 TDI, 2.5 TDI quattro, 2.7 T, 2.7 T quattro, 2.8, 2.8 quattro, 3.0, 3.0 quattro, 3.7, 3.7 quattro, 4.2 quattro, RS6 quattro, S6 quattro		<b>F8-7687</b>		H=80
Control Arm-/Trailing Arm Bush	2.4, 2.4 quattro, 2.5 TDI, 2.5 TDI quattro, 2.7 T, 2.7 T quattro, 2.8, 2.8 quattro	ch.4B-2-000001→; for OE: 1BJ;	<b>F8-7796</b>		H=40; d=10; D=46,5
Control Arm-/Trailing Arm Bush	2.4, 2.4 quattro, 2.5 TDI, 2.5 TDI quattro, 2.7 T, 2.7 T quattro, 2.8, 2.8 quattro	ch.4B-2-000001→; S line; for OE: 1BV;	<b>F8-7796</b>		H=40; d=10; D=46,5
Control Arm-/Trailing Arm Bush	2.4, 2.4 quattro, 2.5 TDI, 2.7, 2.7 quattro, 2.7 T quattro, 3.0, 3.0 quattro	for OE: 1BJ;	<b>F8-7796</b>		H=40; d=10; D=46,5

<b>F8-6430</b>	<b>F8-6431</b>	<b>F8-6470</b>	<b>F8-6471</b>	<b>F8-6530</b>	<b>F8-6758</b>	<b>F8-7097</b>
Ref.Nr.: 4B0501522E	Ref.Nr.: 4B0501521D	Ref.Nr.: 4B0 399 151 AA	Ref.Nr.: 4B0 399 151 P	Ref.Nr.: 4B0 199 379 E	Ref.Nr.: 8D0199339E	Ref.Nr.: 8D0412065D
<b>F8-7148</b>	<b>F8-7577</b>	<b>F8-7599</b>	<b>F8-7687</b>	<b>F8-7796</b>		
Ref.Nr.: 4D0419831A	Ref.Nr.: 8D0 412 131 H	Ref.Nr.: 8E0 199 339	Ref.Nr.: 4D0412137B	Ref.Nr.: 8D0407515C		

**Article Description****Article Nr.****Fitting Position**

<b>A6 (4B2, C5)</b>		<b>01/1997 → 01/2005</b>		
Control Arm-/Trailing Arm Bush	2.4, 2.4 quattro, 2.5 TDI, 2.7, 2.7 quattro, 2.7 T quattro, 3.0, 3.0 quattro	S Line; for OE: 1BV; <b>SP</b>	<b>F8-7796</b>	H=40; d=10; D=46,5
Control Arm-/Trailing Arm Bush	RS6 quattro, S6 quattro		<b>F8-7796</b>	H=40; d=10; D=46,5
Protective Cap/Bellow, shock absorber	1.8, 1.8 T, 1.9 TDI, 2.0, 2.4, 2.5 TDI, 2.7 T, 2.8, 3.0		<b>F8-7802</b>	H=156
Mounting, manual transmission	1.8 T, 2.4, 2.5 TDI, 2.7 T, 2.8, 3.7	ch.4B-Y-045 001→;  5-speed	<b>F8-7971</b>	
Mounting, manual transmission	1.9 TDI, 2.0, 2.4, 2.4 quattro, 2.5 TDI, 2.5 TDI quattro, 2.7, 2.7 T quattro, 2.8, 3.0	5-speed	<b>F8-7971</b>	
Stabiliser Mounting	1.8, 1.8 T, 1.8 T quattro, 1.9 TDI, 2.4, 2.4 quattro, 2.5 TDI, 2.5 TDI quattro, 2.7 T, 2.7 T quattro, 2.8, 2.8 quattro	ch.4B-2-031501→; Stabi. Diam. [mm]=16; <b>SP</b>	<b>F8-7979</b>	
Stabiliser Mounting	1.9 TDI, 2.0, 2.4, 2.4 quattro, 2.5 TDI, 2.7 T quattro, 3.0, 3.0 quattro	Stabi. Diam. [mm]= 16; <b>SP</b>	<b>F8-7979</b>	
Mounting, automatic transmission	1.8		<b>F8-8012</b>	H=66; D=71
Mounting, automatic transmission	1.8 T	ch.F4B-W-065 741→;  AEB, ANB, APU	<b>F8-8012</b>	H=66; D=71
Mounting, automatic transmission	2.4	ch.F4B-W-065 001→;  AGA;  5-speed	<b>F8-8012</b>	H=66; D=71
Mounting, automatic transmission	2.4	ch.F4B-W-065 741→;  5-speed	<b>F8-8012</b>	H=66; D=71
Mounting, automatic transmission	2.5 TDI	ch.F4B-W-065 001→;  AKN;  6-speed	<b>F8-8012</b>	H=66; D=71
Mounting, automatic transmission	1.8 T, 2.0, 2.4, 2.4 quattro, 2.8, 2.8 quattro		<b>F8-8179</b>	
Control Arm-/Trailing Arm Bush	1.8, 1.8 T, 1.8 T quattro, 1.9 TDI, 2.4, 2.4 quattro, 2.5 TDI, 2.5 TDI quattro, 2.7 T quattro, 2.8, 2.8 quattro	01/1998 →	<b>G9-615</b>	H1=66; H2=80; d=12; D=65
Control Arm-/Trailing Arm Bush	2.7 T		<b>G9-615</b>	H1=66; H2=80; d=12; D=65
Control Arm-/Trailing Arm Bush	1.8 T, 1.8 T quattro, 2.4, 2.4 quattro, 2.5 TDI, 2.5 TDI quattro, 2.7 T quattro, 2.8 quattro, 3.7, 3.7 quattro, 4.2 quattro, S6 quattro	for OE: 8D0407505B	<b>G9-616</b>	H1=26; H2=40; d=10; D1=24; D2=46
Control Arm-/Trailing Arm Bush	1.8, 1.8 T quattro, 1.9 TDI, 2.7 T, 2.8		<b>G9-616</b>	H1=26; H2=40; d=10; D1=24; D2=46
Control Arm-/Trailing Arm Bush	1.8, 1.8 T, 1.9 TDI, 2.4, 2.5 TDI, 2.8	01/1998 →	<b>G9-616</b>	H1=26; H2=40; d=10; D1=24; D2=46
Bellow, steering	1.8, 1.8 T, 1.8 T quattro, 1.9 TDI, 2.0, 2.4, 2.4 quattro, 2.5 TDI, 2.5 TDI quattro, 2.7, 2.7 quattro, 2.7 T, 2.7 T quattro, 2.8, 3.0, 3.0 quattro, 3.7, 3.7 quattro, RS6 quattro, S6 quattro	; with clamps;	<b>LM-10021S</b>	d1=20; d2=63; L [mm]=254
Bellow, steering	1.8, 1.8 T, 1.8 T quattro, 1.9 TDI, 2.0, 2.4, 2.4 quattro, 2.5 TDI, 2.5 TDI quattro, 2.7, 2.7 quattro, 2.7 T, 2.7 T quattro, 2.8, 3.0, 3.0 quattro, 3.7, 3.7 quattro, RS6 quattro, S6 quattro	; with clamps;	<b>LM-10021S</b>	d1=20; d2=63; L [mm]=254

<b>F8-7796</b>	<b>F8-7802</b>	<b>F8-7971</b>	<b>F8-7979</b>	<b>F8-8012</b>	<b>F8-8179</b>	<b>G9-615</b>
Ref.Nr.: 8D0407515C	Ref.Nr.: 4B0512137B	Ref.Nr.: 4B0399151M	Ref.Nr.: 4B0511327	Ref.Nr.: 8D0399415E	Ref.Nr.: 8D0399151R	Ref.Nr.: 4D0407183N
<b>G9-616</b>	<b>LM-10021S</b>					
Ref.Nr.: 4D0407515	Ref.Nr.: 8D0419831K					

Article Description



Article Nr.

Fitting Position



### A6 (4B2, C5)

01/1997 → 01/2005

Bellow, steering	2.4, 2.4 quattro, 2.5 TDI, 2.5 TDI quattro, 2.7 T quattro, 2.8, 2.8 quattro	ch.4B-X-090001→;  with clamps;	<b>LM-10021S</b>		d1=20; d2=63; L [mm]=254
Bellow, steering	2.4, 2.4 quattro, 2.5 TDI, 2.5 TDI quattro, 2.7 T quattro, 2.8, 2.8 quattro	ch.4B-X-090001→;  with clamps;	<b>LM-10021S</b>		d1=20; d2=63; L [mm]=254
Bellow Set, drive shaft	2.4	06/2000 →;  AMM; with clamps;	<b>MK-810160</b>		L=116
Bellow Set, drive shaft	2.4	06/2000 →;  ASM; with clamps;	<b>MK-810160</b>		L=116
Bellow Set, drive shaft	2.5 TDI	with clamps; Transmission Type: CVT (Stepless)	<b>MK-810160</b>		L=116
Bellow Set, drive shaft	RS6 quattro	with clamps	<b>MK-810160</b>		L=116

### A6 Avant (4B5, C5)

12/1997 → 01/2005

Dust Cover Kit, shock absorber	1.8, 1.8 T, 1.8 T quattro, 1.9 TDI, 2.0, 2.4, 2.4 quattro, 2.5 TDI, 2.5 TDI quattro, 2.7 T, 2.7 T quattro, 2.8, 2.8 quattro, 3.0, 3.0 quattro		<b>AK-735101</b>		
Dust Cover Kit, shock absorber	1.8, 1.8 T, 1.9 TDI, 2.0, 2.4, 2.5 TDI, 2.7 T, 2.8, 3.0		<b>AK-735127</b>		
Alternator Freewheel Clutch	1.8, 1.8 T, 1.8 T quattro		<b>F5-1002</b>		
Alternator Freewheel Clutch	1.8 T, 1.8 T quattro, 1.9 TDI		<b>F5-1006</b>		
Alternator Freewheel Clutch	1.9 TDI		<b>F5-1008</b>		
Alternator Freewheel Clutch	1.8, 1.8 T, 1.8 T quattro		<b>F5-1012</b>		
Alternator Freewheel Clutch	2.0		<b>F5-1044</b>		
Top Strut Mounting	All Models		<b>F8-3050</b>		H=37; d=12; D1=72; D2=86
Engine Mounting	1.8 T, 2.4		<b>F8-4019</b>		H=47; d=26; D1=48; D2=67
Control Arm-/Trailing Arm Bush	1.8 T, 1.8 T quattro, 2.4, 2.4 quattro, 2.5 TDI, 2.5 TDI quattro, 2.7 T quattro, 2.8 quattro, 3.7, 3.7 quattro, 4.2 quattro, S6 quattro	for OE: 4D0407151E	<b>F8-4044</b>		H1=42; H2=50; d=12; D1=22; D2=40
Control Arm-/Trailing Arm Bush	1.8, 1.8 T, 1.9 TDI, 2.4, 2.5 TDI, 2.8	01/1998 →	<b>F8-4044</b>		H1=42; H2=50; d=12; D1=22; D2=40
Control Arm-/Trailing Arm Bush	2.7 T		<b>F8-4044</b>		H1=42; H2=50; d=12; D1=22; D2=40
Control Arm-/Trailing Arm Bush	1.8 T, 1.8 T quattro, 2.4, 2.4 quattro, 2.5 TDI, 2.5 TDI quattro, 2.7 T quattro, 2.8 quattro, 3.7, 3.7 quattro, 4.2 quattro, S6 quattro	for OE: 4D0407151E	<b>F8-4045</b>		H1=31; H2=60; d=12; D=50
Control Arm-/Trailing Arm Bush	1.8, 1.8 T, 1.9 TDI, 2.4, 2.5 TDI, 2.8	01/1998 →	<b>F8-4045</b>		H1=31; H2=60; d=12; D=50
Control Arm-/Trailing Arm Bush	1.8, 1.9 TDI, 2.0, 2.4, 2.4 quattro, 2.5 TDI, 2.7 T, 2.7 T quattro, 2.8, 3.0, 3.0 quattro		<b>F8-4045</b>		H1=31; H2=60; d=12; D=50
Stabiliser Mounting	1.8, 1.8 T, 2.4, 2.5 TDI, 2.7 T		<b>F8-5064</b>		H=44; d=27
Rubber Buffer, engine mounting	2.5 TDI, 2.5 TDI quattro		<b>F8-5524</b>		d=26; L=47; D=68
Mounting, radiator	All Models		<b>F8-5526</b>		d=15; D=40; Thick. [mm]=25
Engine Mounting	1.8, 1.8 T, 1.8 T quattro		<b>F8-5538</b>		

<b>AK-735101</b>	<b>AK-735127</b>	<b>F5-1002</b>	<b>F5-1006</b>	<b>F5-1008</b>	<b>F5-1012</b>	<b>F5-1044</b>
Ref.Nr.: 4D0412137C	Ref.Nr.:	Ref.Nr.: 038903119P	Ref.Nr.: 038903119M	Ref.Nr.: 028903119AN	Ref.Nr.: 058903119C	Ref.Nr.: 06B903119B
<b>F8-3050</b>	<b>F8-4019</b>	<b>F8-4044</b>	<b>F8-4045</b>	<b>F8-5064</b>	<b>F8-5524</b>	<b>F8-5526</b>
Ref.Nr.: 4D0412377D	Ref.Nr.: 893199339	Ref.Nr.: 4D0407181H	Ref.Nr.: 4D0407182E	Ref.Nr.: 4D0411327F	Ref.Nr.: 893199339A	Ref.Nr.: 8D0121275
<b>F8-5538</b>	<b>F8-5542</b>	<b>LM-10021S</b>	<b>MK-810160</b>			
Ref.Nr.: 8D0199382L	Ref.Nr.: 4B0407515	Ref.Nr.: 8D0419831K	Ref.Nr.: 3D0 498 201			

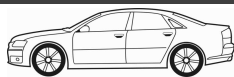
**Article Description**

**Article Nr.**
**Fitting Position**

<b>A6 Avant (4B5, C5)</b>			<b>12/1997 → 01/2005</b>		
Control Arm-/Trailing Arm Bush	1.8 T	ch.4B-X-000001→	<b>F8-5542</b>		H=40; d=10; D=46
Control Arm-/Trailing Arm Bush	1.8, 1.8 T, 1.8 T quattro, 1.9 TDI, 2.4, 2.4 quattro, 2.5 TDI, 2.5 TDI quattro, 2.8, 2.8 quattro	ch.4B-X-000001→; 08/1998 →	<b>F8-5542</b>		H=40; d=10; D=46
Control Arm-/Trailing Arm Bush	1.9 TDI, 2.0, 2.4, 2.5 TDI, 2.7 T, 2.7 T quattro, 2.8, 3.0, 3.0 quattro, 3.7, 4.2 quattro, RS6 plus quattro, RS6 quattro, S6 quattro		<b>F8-5542</b>		H=40; d=10; D=46
Control Arm-/Trailing Arm Bush	2.4 quattro, 2.5 TDI quattro, 3.7 quattro	not for PR: 1BV;	<b>F8-5542</b>		H=40; d=10; D=46
Mounting, radiator	All Models		<b>F8-5548</b>		
Engine Mounting	1.8, 1.8 T, 1.8 T quattro		<b>F8-5565</b>		
Engine Mounting	2.4, 2.4 quattro, 2.5 TDI, 2.5 TDI quattro, 2.7 T, 2.7 T quattro, 2.8, 2.8 quattro, 3.0, 3.0 quattro		<b>F8-5567</b>		
Top Strut Mounting	1.8, 1.8 T, 1.9 TDI, 2.0, 2.4, 2.5 TDI, 2.7 T, 2.8, 3.0, 3.7		<b>F8-5572</b>		
Mounting, automatic transmission	1.8	ch.4B-1-039836, 4B-Y-062561→;  AQE, ARH;  4-speed	<b>F8-5574</b>		
Mounting, automatic transmission	1.8	ch.4B-Y-062561→;  4-speed	<b>F8-5574</b>		
Mounting, automatic transmission	1.8 T	ch.4B-Y-062561→; 05/2000 →;  AWT; Transmission Type: CVT (Stepless)	<b>F8-5574</b>		
Mounting, automatic transmission	1.8 T	ch.4B-Y-062561→; 11/1999 →;  5-speed	<b>F8-5574</b>		
Mounting, automatic transmission	1.8 T	ch.4B-Y-062561→; 11/1999 →;  ANB, APU;  5-speed	<b>F8-5574</b>		
Mounting, automatic transmission	1.8 T quattro, S6 quattro		<b>F8-5574</b>		
Mounting, automatic transmission	1.8, 1.9 TDI	ch.4B-2-150001, 4B-Y-062561→; Transmission Type: CVT (Stepless)	<b>F8-5574</b>		
Mounting, automatic transmission	1.9 TDI	ch.4B-1-039836, 4B-Y-062561→;  4-speed	<b>F8-5574</b>		
Mounting, automatic transmission	1.9 TDI	ch.4B-1-039836→;  4-speed	<b>F8-5574</b>		
Mounting, automatic transmission	2.0	Transmission Type: CVT (Stepless)	<b>F8-5574</b>		
Mounting, automatic transmission	2.4	ch.→4B-W-065000; Transmission Type: CVT (Stepless)	<b>F8-5575</b>		H=72; D=71
Mounting, automatic transmission	2.4	ch.4B-W-065001→; ch.→4B-W-065000;  AJG, AMM, APZ	<b>F8-5575</b>		H=72; D=71
Mounting, automatic transmission	2.4	ch.4B-W-065001→; ch.→4B-W-065000;  AML	<b>F8-5575</b>		H=72; D=71
Mounting, automatic transmission	2.4 quattro, 2.5 TDI, 2.8	ch.4B-W-065001→; ch.→4B-W-065000	<b>F8-5575</b>		H=72; D=71
Mounting, automatic transmission	2.4 quattro, 2.7 T quattro, 3.0 quattro	ch.→4B-5-050000	<b>F8-5575</b>		H=72; D=71

<b>F8-5542</b>	<b>F8-5548</b>	<b>F8-5565</b>	<b>F8-5567</b>	<b>F8-5572</b>	<b>F8-5574</b>	<b>F8-5575</b>
Ref.Nr.: 4B0407515	Ref.Nr.: 4A0018977	Ref.Nr.: 8D0199379S	Ref.Nr.: 8D0199379K	Ref.Nr.: 8E0513353B	Ref.Nr.: 8D0399419G	Ref.Nr.: 8D0399415D

Article Description			Article Nr.	Fitting Position	
---------------------	--	--	-------------	------------------	--

<b>A6 Avant (4B5, C5)</b>			<b>12/1997 → 01/2005</b>		
Mounting, automatic transmission	2.4, 2.4 quattro, S6 quattro	ch.4B-W-056741→; ch.→4B-W-056740	<b>F8-5575</b>		H=72; D=71
Mounting, automatic transmission	2.4, 2.5 TDI	ch.→4B-5-050000; Transmission Type: CVT (Stepless)	<b>F8-5575</b>		H=72; D=71
Mounting, automatic transmission	2.5 TDI	AKE, APR	<b>F8-5575</b>		H=72; D=71
Mounting, automatic transmission	2.5 TDI quattro	ch.4B-W-056741→; ch.→4B-W-056740; Transmission Type: CVT (Stepless)	<b>F8-5575</b>		H=72; D=71
Mounting, automatic transmission	2.5 TDI quattro	AKE, APR, BAU, BDH	<b>F8-5575</b>		H=72; D=71
Mounting, automatic transmission	2.7 T	Transmission Type: CVT (Stepless)	<b>F8-5575</b>		H=72; D=71
Mounting, automatic transmission	2.7 T quattro, 2.8 quattro	ch.4B-W-065001→; ch.→4B-W-065000; Transmission Type: CVT (Stepless)	<b>F8-5575</b>		H=72; D=71
Mounting, automatic transmission	2.8	ch.4B-W-065001→; ch.→4B-W-065000;  ACK, ALG, APR, AQD	<b>F8-5575</b>		H=72; D=71
Mounting, automatic transmission	3.0	ch.4B-W-065001→; ch.→4B-W-050000, 4B-W-065000; Transmission Type: CVT (Stepless)	<b>F8-5575</b>		H=72; D=71
Mounting, automatic transmission	4.2 quattro	ch.4B-W-056741→; ch.→4B-W-056740;  ARS, ASG	<b>F8-5575</b>		H=72; D=71
Mounting, automatic transmission	2.4, 2.4 quattro, 2.8	ch.→4B-X-100000;	<b>F8-5576</b>		
Mounting, automatic transmission	2.4, 2.4 quattro, 2.7 T quattro, 2.8, 2.8 quattro	ch.→4BX100001	<b>F8-5577</b>		
Mounting, manual transmission	1.8, 1.8 T, 1.8 T quattro		<b>F8-5578</b>		
Engine Mounting	1.9 TDI		<b>F8-5579</b>		
Belt Pulley, crankshaft	2.0		<b>F8-5650</b>		
Belt Pulley, crankshaft	1.9 TDI		<b>F8-5654</b>		
Rubber Buffer, suspension	1.8, 1.8 T, 1.8 T quattro, 1.9 TDI, 2.0, 2.4, 2.4 quattro, 2.5 TDI, 2.5 TDI quattro, 2.7 T, 2.7 T quattro, 2.8, 2.8 quattro, 3.0, 3.0 quattro, 3.7, 3.7 quattro, 4.2 quattro		<b>F8-5994</b>		H=85
Rubber Buffer, suspension	1.8, 1.8 T, 1.9 TDI, 2.4, 2.5 TDI, 2.7 T, 2.8		<b>F8-6001</b>		H=134
Rubber Buffer, suspension	1.8, 1.8 T, 1.9 TDI, 2.4, 2.5 TDI, 2.7 T, 2.8		<b>F8-6003</b>		H=103.5
Rubber Buffer, suspension	1.8, 1.8 T, 1.8 T quattro, 1.9 TDI, 2.4, 2.4 quattro, 2.5 TDI, 2.5 TDI quattro, 2.7 T, 2.7 T quattro, 2.8, 2.8 quattro		<b>F8-6005</b>		H=134
Rubber Buffer, suspension	1.8, 1.8 T, 1.8 T quattro, 1.9 TDI, 2.0, 2.4, 2.4 quattro, 2.5 TDI, 2.5 TDI quattro, 2.7 T, 2.7 T quattro, 2.8, 2.8 quattro, 3.0, 3.0 quattro, 3.7, 3.7 quattro, 4.2 quattro, S6 quattro		<b>F8-6039</b>		H=77
Spring Cap	All Models		<b>F8-6283</b>		
Repair Kit, suspension strut	1.8, 1.8 T, 1.9 TDI, 2.0, 2.4, 2.5 TDI, 2.7 T, 2.8, 3.0, 3.7		<b>F8-6344</b>		

<b>F8-5575</b>	<b>F8-5576</b>	<b>F8-5577</b>	<b>F8-5578</b>	<b>F8-5579</b>	<b>F8-5650</b>	<b>F8-5654</b>
Ref.Nr.: 8D0399415D	Ref.Nr.: 8D0399151M	Ref.Nr.: 8D0399151J	Ref.Nr.: 8D0399151H	Ref.Nr.: 8D0199382G	Ref.Nr.: 06A105243E	Ref.Nr.: 028105243Q
<b>F8-5994</b>	<b>F8-6001</b>	<b>F8-6003</b>	<b>F8-6005</b>	<b>F8-6039</b>	<b>F8-6283</b>	<b>F8-6344</b>
Ref.Nr.: 8D0412131F	Ref.Nr.: 3B0512131H	Ref.Nr.: 4B0512131B	Ref.Nr.: 4B0512131N	Ref.Nr.: 8D0412131E	Ref.Nr.: 8D0412065E	Ref.Nr.: 8E0513353B
<b>F8-6391</b>						
Ref.Nr.: 038105243F						



**Article Description****Article Nr.****Fitting Position**

<b>A6 Avant (4B5, C5)</b>			<b>12/1997 → 01/2005</b>	
Belt Pulley, crankshaft	1.9 TDI	Number of Ribs: 7	<b>F8-6391</b>	
Mounting, axle beam	1.8, 1.8 T, 1.9 TDI, 2.0, 2.4, 2.5 TDI, 2.7 T, 2.8, 3.0, 3.7	Paired article nr: F8-6431	<b>F8-6430</b>	
Mounting, axle beam	1.8, 1.8 T, 1.9 TDI, 2.0, 2.4, 2.5 TDI, 2.7 T, 2.8, 3.0, 3.7	Paired article nr: F8-6430	<b>F8-6431</b>	
Mounting, automatic transmission	All Models		<b>F8-6470</b>	
Mounting, automatic transmission	1.8, 1.8 T, 1.9 TDI, 2.0, 2.4, 2.5 TDI, 2.7 T, 2.8, 3.0, 3.7		<b>F8-6471</b>	
Engine Mounting	2.5 TDI, 2.5 TDI quattro		<b>F8-6530</b>	
Rubber Buffer, engine mounting	2.7 T, 2.7 T quattro	ch.→4B-5-050000	<b>F8-6758</b>	
Repair Kit, suspension strut	All Models		<b>F8-7097</b>	
Bellow, steering	2.4, 2.4 quattro, 2.5 TDI, 2.5 TDI quattro, 2.7 T, 2.7 T quattro, 2.8, 2.8 quattro, 3.0, 3.0 quattro	for vehicles with steering damper	<b>F8-7148</b>	
Rubber Buffer, suspension	1.8, 1.8 T, 1.8 T quattro, 1.9 TDI, 2.0, 2.4, 2.4 quattro, 2.5 TDI, 2.5 TDI quattro, 2.7 T, 2.7 T quattro, 2.8, 2.8 quattro, 3.0, 3.0 quattro, 3.7, 3.7 quattro, 4.2 quattro	for OE: 1BA, 1BG; <b>ST</b> ; <b>II</b>	<b>F8-7577</b>	
Rubber Buffer, engine mounting	2.0, 3.0, 3.0 quattro		<b>F8-7599</b>	
Protective Cap/Bellow, shock absorber	All Models		<b>F8-7687</b>	
Control Arm-/Trailing Arm Bush	2.4, 2.4 quattro, 2.5 TDI, 2.5 TDI quattro, 2.7 T, 2.7 T quattro, 2.8, 2.8 quattro	ch.4B-2-000001→; for OE: 1BJ; <b>Ø</b>	<b>F8-7796</b>	
Control Arm-/Trailing Arm Bush	2.4, 2.4 quattro, 2.5 TDI, 2.5 TDI quattro, 2.7 T, 2.7 T quattro, 2.8, 2.8 quattro	ch.4B-2-000001→; S line; for OE: 1BV; <b>SP</b>	<b>F8-7796</b>	
Control Arm-/Trailing Arm Bush	2.4, 2.4 quattro, 2.5 TDI, 2.7 T quattro, 3.0, 3.0 quattro	for OE: 1BJ; <b>Ø</b>	<b>F8-7796</b>	
Control Arm-/Trailing Arm Bush	2.4, 2.4 quattro, 2.5 TDI, 2.7 T quattro, 3.0, 3.0 quattro	S line; for OE: 1BV; <b>SP</b>	<b>F8-7796</b>	
Control Arm-/Trailing Arm Bush	RS6 plus quattro, RS6 quattro, S6 quattro		<b>F8-7796</b>	
Protective Cap/Bellow, shock absorber	1.8, 1.8 T, 1.9 TDI, 2.0, 2.4, 2.5 TDI, 2.7 T, 2.8, 3.0	<b>Δ</b>	<b>F8-7802</b>	
Mounting, manual transmission	1.8 T, 2.4, 2.7 T, 2.8, 3.7	ch.4B-Y-045 001→; <b>5</b> 5-speed	<b>F8-7971</b>	
Mounting, manual transmission	1.9 TDI, 2.0, 2.4, 2.4 quattro, 2.5 TDI, 2.5 TDI quattro, 2.7 T quattro, 3.0	<b>5</b> 5-speed	<b>F8-7971</b>	
Stabiliser Mounting	1.8, 1.8 T, 1.8 T quattro, 1.9 TDI, 2.4, 2.4 quattro, 2.5 TDI, 2.5 TDI quattro, 2.7 T, 2.7 T quattro, 2.8, 2.8 quattro	ch.4B-2-031501→; Stabi. Diam. [mm]=16; <b>SP</b>	<b>F8-7979</b>	
Stabiliser Mounting	1.9 TDI, 2.0, 2.4, 2.4 quattro, 2.5 TDI, 2.7 T quattro, 3.0, 3.0 quattro	Stabi. Diam. [mm]=16; <b>SP</b>	<b>F8-7979</b>	
Mounting, automatic transmission	1.8		<b>F8-8012</b>	
Mounting, automatic transmission	1.8 T	ch.F4B-W-065 741→; <b>5</b> AEB, ANB, APU	<b>F8-8012</b>	

<b>F8-6391</b>	<b>F8-6430</b>	<b>F8-6431</b>	<b>F8-6470</b>	<b>F8-6471</b>	<b>F8-6530</b>	<b>F8-6758</b>
Ref.Nr.: 038105243F	Ref.Nr.: 4B0501522E	Ref.Nr.: 4B0501521D	Ref.Nr.: 4B0 399 151 AA	Ref.Nr.: 4B0 399 151 P	Ref.Nr.: 4B0 199 379 E	Ref.Nr.: 8D0199339E
<b>F8-7097</b>	<b>F8-7148</b>	<b>F8-7577</b>	<b>F8-7599</b>	<b>F8-7687</b>	<b>F8-7796</b>	<b>F8-7802</b>
Ref.Nr.: 8D0412065D	Ref.Nr.: 4D0419831A	Ref.Nr.: 8D0 412 131 H	Ref.Nr.: 8E0 199 339	Ref.Nr.: 4D0412137B	Ref.Nr.: 8D0407515C	Ref.Nr.: 4B0512137B
<b>F8-7971</b>	<b>F8-7979</b>	<b>F8-8012</b>				
Ref.Nr.: 4B0399151M	Ref.Nr.: 4B0511327	Ref.Nr.: 8D0399415E				

Article Description



Article Nr.

Fitting Position



### A6 Avant (4B5, C5)

12/1997 → 01/2005

Mounting, automatic transmission	2.4	ch.F4B-W-065 001→;  AGA;  5-speed	<b>F8-8012</b>		H=66; D=71
Mounting, automatic transmission	2.4	ch.F4B-W-065 741→;  5-speed	<b>F8-8012</b>		H=66; D=71
Mounting, automatic transmission	2.5 TDI	ch.F4B-W-065 001→;  AKN;  6-speed	<b>F8-8012</b>		H=66; D=71
Mounting, automatic transmission	1.8 T, 2.0, 2.4, 2.4 quattro, 2.8, 2.8 quattro		<b>F8-8179</b>		
Control Arm-/Trailing Arm Bush	1.8, 1.8 T, 1.8 T quattro, 1.9 TDI, 2.4, 2.4 quattro, 2.5 TDI, 2.5 TDI quattro, 2.7 T quattro, 2.8, 2.8 quattro	01/1998 →	<b>G9-615</b>		H1=66; H2=80; d=12; D=65
Control Arm-/Trailing Arm Bush	2.7 T		<b>G9-615</b>		H1=66; H2=80; d=12; D=65
Control Arm-/Trailing Arm Bush	1.8 T quattro, 2.4 quattro, 2.5 TDI quattro, 2.7 T quattro, 2.8 quattro	ch.4B-W-180001→; 01/1998 →	<b>G9-616</b>		H1=26; H2=40; d=10; D1=24; D2=46
Control Arm-/Trailing Arm Bush	1.8 T, 1.8 T quattro, 2.4, 2.5 TDI, 2.5 TDI quattro, 3.7, 3.7 quattro, 4.2 quattro, S6 quattro	for OE: 8D0407505B	<b>G9-616</b>		H1=26; H2=40; d=10; D1=24; D2=46
Control Arm-/Trailing Arm Bush	1.8, 1.8 T, 1.9 TDI, 2.4, 2.5 TDI, 2.8	01/1998 →	<b>G9-616</b>		H1=26; H2=40; d=10; D1=24; D2=46
Control Arm-/Trailing Arm Bush	1.8, 1.9 TDI, 2.7 T, 2.8		<b>G9-616</b>		H1=26; H2=40; d=10; D1=24; D2=46
Bellow, steering	1.8, 1.8 T, 1.8 T quattro, 1.9 TDI, 2.0, 2.4, 2.4 quattro, 2.5 TDI, 2.5 TDI quattro, 2.7 T, 2.7 T quattro, 2.8, 3.0, 3.0 quattro, 3.7, 3.7 quattro, RS6 plus quattro, RS6 quattro, S6 quattro	; with clamps;	<b>LM-10021S</b>		d1=20; d2=63; L [mm]=254
Bellow, steering	1.8, 1.8 T, 1.8 T quattro, 1.9 TDI, 2.0, 2.4, 2.4 quattro, 2.5 TDI, 2.5 TDI quattro, 2.7 T, 2.7 T quattro, 2.8, 3.0, 3.0 quattro, 3.7, 3.7 quattro, RS6 plus quattro, RS6 quattro, S6 quattro	; with clamps;	<b>LM-10021S</b>		d1=20; d2=63; L [mm]=254
Bellow, steering	2.4, 2.4 quattro, 2.5 TDI, 2.5 TDI quattro, 2.7 T quattro, 2.8, 2.8 quattro	ch.4B-X-090001→; ; with clamps;	<b>LM-10021S</b>		d1=20; d2=63; L [mm]=254
Bellow, steering	2.4, 2.4 quattro, 2.5 TDI, 2.5 TDI quattro, 2.7 T quattro, 2.8, 2.8 quattro	ch.4B-X-090001→; ; with clamps;	<b>LM-10021S</b>		d1=20; d2=63; L [mm]=254
Bellow Set, drive shaft	2.4	06/2000 →;  AMM; with clamps;	<b>MK-810160</b>		L=116
Bellow Set, drive shaft	2.4	06/2000 →;  ASM; with clamps;	<b>MK-810160</b>		L=116
Bellow Set, drive shaft	2.5 TDI	with clamps; Transmission Type: CVT (Stepless)	<b>MK-810160</b>		L=116
Bellow Set, drive shaft	RS6 quattro	with clamps	<b>MK-810160</b>		L=116

### A6 (4F2, C6)

05/2004 → 03/2011

Alternator Freewheel Clutch	2.0 TDI		<b>F5-1004</b>		
Alternator Freewheel Clutch	2.0 TFSI		<b>F5-1044</b>		
Alternator Freewheel Clutch	2.0 TDI		<b>F5-1085</b>		
Alternator Freewheel Clutch	2.7 TDI, 2.7 TDI quattro, 3.0 TDI quattro		<b>F5-1140</b>		

<b>F5-1004</b>	<b>F5-1044</b>	<b>F5-1085</b>	<b>F5-1140</b>	<b>F5-1149</b>	<b>F8-8012</b>	<b>F8-8179</b>
Ref.Nr.: 038903119T	Ref.Nr.: 06B903119B	Ref.Nr.: 045903119A	Ref.Nr.: 059903119L	Ref.Nr.: 06E903119R	Ref.Nr.: 8D0399415E	Ref.Nr.: 8D0399151R
<b>G9-615</b>	<b>G9-616</b>	<b>LM-10021S</b>	<b>MK-810160</b>			
Ref.Nr.: 4D0407183N	Ref.Nr.: 4D0407515	Ref.Nr.: 8D0419831K	Ref.Nr.: 3D0 498 201			

**Article Description****Article Nr.****Fitting Position**

<b>A6 (4F2, C6)</b>				<b>05/2004 → 03/2011</b>	
Alternator Freewheel Clutch	2.8 FSI, 2.8 FSI quattro, 3.0 TFSI quattro, 3.2 FSI, 3.2 FSI quattro		<b>F5-1149</b>		
Mounting, automatic transmission	2.4		<b>F8-5576</b>		
Rubber Buffer, suspension	2.0 TDI, 2.0 TFSI, 2.4, 2.4 quattro, 2.7 TDI, 2.7 TDI quattro, 2.8 FSI, 2.8 FSI quattro, 3.0, 3.0 quattro, 3.0 TDI, 3.0 TDI quattro, 3.0 TFSI quattro, 3.2 FSI, 3.2 FSI quattro, 4.2 FSI quattro, 4.2 quattro		<b>F8-5994</b>		H=85
Top Strut Mounting	2.0 TDI, 2.0 TFSI, 2.4, 2.4 quattro, 2.7 TDI, 2.7 TDI quattro, 2.8 FSI, 2.8 FSI quattro, 3.0, 3.0 quattro, 3.0 TDI, 3.0 TDI quattro, 3.0 TFSI quattro, 3.2 FSI, 3.2 FSI quattro, 4.2 FSI quattro, 4.2 quattro, S6 quattro		<b>F8-6352</b>		
Belt Pulley, crankshaft	2.0 TDI	Number of Ribs: 5; Parameter: 6PK	<b>F8-6396</b>		H=41.6; d=30; Mounting points diam.[mm]=7, 8.6; D=139.7
Mounting, axle beam	2.0 TDI	BLB; Paired article nr: F8-6431	<b>F8-6430</b>		
Mounting, axle beam	2.0 TDI	BNA; Paired article nr: F8-6431	<b>F8-6430</b>		
Mounting, axle beam	2.4, 2.7 TDI, 3.0, 3.2 FSI	Paired article nr: F8-6431	<b>F8-6430</b>		
Mounting, axle beam	2.0 TDI	BLB; Paired article nr: F8-6430	<b>F8-6431</b>		
Mounting, axle beam	2.0 TDI	BNA; Paired article nr: F8-6430	<b>F8-6431</b>		
Mounting, axle beam	2.4, 2.7 TDI, 3.0, 3.2 FSI	Paired article nr: F8-6430	<b>F8-6431</b>		
Engine Mounting	2.0 TDI	Operating Mode: Electric	<b>F8-6534</b>		Outer Thread 1 [mm]=M10 x 1,50 RHT M; Outer Thread 2 [mm]=M10 x 1,50 RHT M
Control Arm-/Trailing Arm Bush	2.0 TDI, 2.0 TFSI, 2.4, 2.4 quattro, 2.7 TDI, 2.7 TDI quattro, 2.8 FSI, 2.8 FSI quattro, 3.0, 3.0 quattro, 3.0 TDI, 3.0 TDI quattro, 3.0 TFSI quattro, 3.2 FSI, 3.2 FSI quattro, 4.2 FSI quattro, 4.2 quattro, RS6 quattro, S6 quattro		<b>F8-6580</b>		d=12.1; L=80; D=65
Engine Mounting	2.0 TDI	Yellow; with cap	<b>F8-6742</b>		
Engine Mounting	2.0 TDI	Yellow;  BNA, BRF; with cap	<b>F8-6742</b>		
Engine Mounting	2.0 TFSI	ch.4F-6-065001 →; Yellow; with cap; Transmission Type: CVT (Stepless)	<b>F8-6742</b>		
Engine Mounting	2.4, 2.4 quattro, 2.8 FSI, 2.8 FSI quattro, 3.0, 3.0 quattro, 3.2 FSI quattro	Green; with cap	<b>F8-6743</b>		
Engine Mounting	2.8 FSI, 2.8 FSI quattro	Green; with cap; Transmission Type: CVT (Stepless),  6-speed	<b>F8-6743</b>		
Engine Mounting	3.2 FSI, 3.2 FSI quattro	ch.4F-5-087151 →; Green; with cap;  6-speed	<b>F8-6743</b>		
Engine Mounting	3.2 FSI, 3.2 FSI quattro	ch.4F-6-000001 →; Green; with cap; Transmission Type: CVT (Stepless)	<b>F8-6743</b>		
Engine Mounting	2.0 TFSI	with cap	<b>F8-6744</b>		
Engine Mounting	2.4, 2.4 quattro, 3.0 quattro	Red; with cap	<b>F8-6745</b>		

<b>F5-1149</b>	<b>F8-5576</b>	<b>F8-5994</b>	<b>F8-6352</b>	<b>F8-6396</b>	<b>F8-6430</b>	<b>F8-6431</b>
Ref.Nr.: 06E903119R	Ref.Nr.: 8D0399151M	Ref.Nr.: 8D0412131F	Ref.Nr.: 4F0513353B	Ref.Nr.: 03G105243	Ref.Nr.: 4B0501522E	Ref.Nr.: 4B0501521D
<b>F8-6534</b>	<b>F8-6580</b>	<b>F8-6742</b>	<b>F8-6743</b>	<b>F8-6744</b>	<b>F8-6745</b>	
Ref.Nr.: 4F0199379AS	Ref.Nr.: 4F0407183C	Ref.Nr.: 4F0199382AS	Ref.Nr.: 4F0199379AP	Ref.Nr.: 4F0199379AQ	Ref.Nr.: 4F0199382AQ	

## Article Description



Article Nr.

Fitting Position



A6 (4F2, C6)			05/2004 → 03/2011		
Engine Mounting	2.8 FSI, 2.8 FSI quattro	Red; with cap; Transmission Type: CVT (Stepless), 6-speed	F8-6745		
Engine Mounting	3.2 FSI, 3.2 FSI quattro	ch.4F-5-087151→; Red; with cap; 6-speed	F8-6745		
Engine Mounting	3.2 FSI, 3.2 FSI quattro	ch.4F-6-000001→; Red; with cap; Transmission Type: CVT (Stepless)	F8-6745		
Engine Mounting	2.0 TFSI	ch.→4F-6-065000; Violet; with cap;	F8-6746		
Control Arm-/Trailing Arm Bush	All Models		F8-6784		H=45; d=12.2; D=43.8
Top Strut Mounting	2.0 TDI, 2.0 TFSI, 2.4, 2.4 quattro, 2.7 TDI, 2.7 TDI quattro, 2.8 FSI, 2.8 FSI quattro, 3.0, 3.0 quattro, 3.0 TDI, 3.0 TDI quattro, 3.0 TFSI quattro, 3.2 FSI, 3.2 FSI quattro, 4.2 FSI quattro, 4.2 quattro, RS6 quattro, S6 quattro		F8-7454		
Rubber Buffer, suspension	2.0 TDI, 2.0 TFSI, 2.4, 2.4 quattro, 2.7 TDI, 2.7 TDI quattro, 2.8 FSI, 2.8 FSI quattro, 3.0, 3.0 quattro, 3.0 TDI, 3.0 TDI quattro, 3.2 FSI, 3.2 FSI quattro, 4.2 FSI quattro, 4.2 quattro, S6 quattro	for OE: 1BA, 1BR;	F8-7577		H=94
Rubber Buffer, suspension	2.0 TDI, 2.7 TDI, 2.7 TDI quattro, 2.8 FSI, 2.8 FSI quattro, 3.0 TDI quattro, 3.0 TFSI quattro	for OE: 1BA, 1BB, 1BR;	F8-7577		H=94
Rubber Buffer, suspension	3.0 TFSI quattro		F8-7577		H=94
Rubber Buffer, suspension	2.0 TDI, 2.0 TFSI, 2.4, 2.4 quattro, 2.7 TDI, 2.7 TDI quattro, 2.8 FSI, 2.8 FSI quattro, 3.0, 3.0 quattro, 3.0 TDI, 3.0 TDI quattro, 3.2 FSI, 3.2 FSI quattro, 4.2 FSI quattro, 4.2 quattro, RS6 quattro, S6 quattro	for OE: 1BA;	F8-7578		H=146
Rubber Buffer, engine mounting	2.0 TDI	BLB	F8-7599		
Rubber Buffer, engine mounting	2.0 TDI	BNA	F8-7599		
Rubber Buffer, engine mounting	2.4, 2.4 quattro, 2.7 TDI, 3.0, 3.0 quattro, 3.0 TDI quattro, 4.2 quattro		F8-7599		
Rubber Buffer, engine mounting	2.7 TDI	BSG	F8-7599		
Rubber Buffer, engine mounting	3.0 TDI quattro	BNG	F8-7599		
Rubber Buffer, engine mounting	3.2 FSI, 3.2 FSI quattro	AUK	F8-7599		
Protective Cap/Bellow, shock absorber	All Models		F8-7682		H=160
Protective Cap/Bellow, shock absorber	2.0 TDI, 2.0 TFSI, 2.4, 2.4 quattro, 2.7 TDI, 2.7 TDI quattro, 2.8 FSI, 2.8 FSI quattro, 3.0, 3.0 quattro, 3.0 TDI, 3.0 TDI quattro, 3.0 TFSI quattro, 3.2 FSI, 3.2 FSI quattro, 4.2 FSI quattro, 4.2 quattro, S6 quattro		F8-7687		H=80

<b>F8-6745</b>	<b>F8-6746</b>	<b>F8-6784</b>	<b>F8-7454</b>	<b>F8-7577</b>	<b>F8-7578</b>	<b>F8-7599</b>
Ref.Nr.: 4F0199382AQ	Ref.Nr.: 4F0199382BJ	Ref.Nr.: 4E0407181B	Ref.Nr.: 4F0412377B	Ref.Nr.: 8D0 412 131 H	Ref.Nr.: 4F0 512 131	Ref.Nr.: 8E0 199 339
<b>F8-7682</b>	<b>F8-7687</b>	<b>F8-7707</b>				
Ref.Nr.: 8E0512137E	Ref.Nr.: 4D0412137B	Ref.Nr.: 4F0512131A				

**Article Description****Article Nr.****Fitting Position**

<b>A6 (4F2, C6)</b>		<b>05/2004 → 03/2011</b>		
Rubber Buffer, suspension	2.0 TDI, 2.0 TFSI, 2.4, 2.4 quattro, 2.7 TDI, 2.7 TDI quattro, 2.8 FSI, 2.8 FSI quattro, 3.0, 3.0 quattro, 3.0 TDI, 3.0 TDI quattro, 3.2 FSI, 3.2 FSI quattro, 4.2 FSI quattro, 4.2 quattro, S6 quattro		<b>F8-7707</b>	H=100
Control Arm-/Trailing Arm Bush	All Models		<b>F8-7795</b>	
Control Arm-/Trailing Arm Bush	2.0 TDI, 2.0 TFSI, 2.4, 2.4 quattro, 2.7 TDI, 2.7 TDI quattro, 2.8 FSI, 2.8 FSI quattro, 3.0, 3.0 quattro, 3.0 TDI, 3.0 TDI quattro, 3.0 TFSI quattro, 3.2 FSI, 3.2 FSI quattro		<b>F8-7796</b>	H=40; d=10; D=46,5
Control Arm-/Trailing Arm Bush	3.0 TDI quattro	BNG	<b>F8-7796</b>	H=40; d=10; D=46,5
Control Arm-/Trailing Arm Bush	4.2 FSI quattro, 4.2 quattro, RS6 quattro, S6 quattro	for OE: 1BA, 1BB, 1BE, 1BK, 1BR, 1BV, 1BY	<b>F8-7796</b>	H=40; d=10; D=46,5
Protective Cap/Bellow, shock absorber	2.0 TDI, 2.0 TFSI, 2.4, 2.4 quattro, 2.7 TDI, 2.7 TDI quattro, 2.8 FSI, 2.8 FSI quattro, 3.0 quattro, 3.0 TDI quattro, 3.0 TFSI quattro, 3.2 FSI, 3.2 FSI quattro	for OE: 1BB, 1BR;	<b>F8-7802</b>	H=156
Protective Cap/Bellow, shock absorber	2.0 TDI, 2.0 TFSI, 2.4, 2.4 quattro, 2.7 TDI, 2.7 TDI quattro, 2.8 FSI, 2.8 FSI quattro, 3.0 quattro, 3.0 TDI quattro, 3.0 TFSI quattro, 3.2 FSI, 3.2 FSI quattro	for OE: 1BK;	<b>F8-7802</b>	H=156
Rubber Buffer, suspension	RS6 quattro		<b>F8-7844</b>	
Rubber Buffer, suspension	S6 quattro	for OE: 1BD;	<b>F8-7844</b>	
Stabiliser Mounting	2.0 TDI, 2.0 TFSI, 2.4, 2.4 quattro, 2.7 TDI, 2.7 TDI quattro, 2.8 FSI, 2.8 FSI quattro, 3.0, 3.0 quattro, 3.0 TDI, 3.0 TDI quattro, 3.2 FSI, 3.2 FSI quattro, 4.2 FSI quattro, 4.2 quattro, RS6 quattro, S6 quattro		<b>F8-7922</b>	d=29
Engine Mounting	3.0 TDI quattro		<b>F8-7970</b>	
Mounting, manual transmission	2.0 TDI	ch.→4F-5-200000;  BLB; Transmission Type: CVT (Stepless)	<b>F8-7972</b>	
Mounting, manual transmission	2.0 TDI	ch.→4F-5-200000;  BNA; Transmission Type: CVT (Stepless)	<b>F8-7972</b>	
Mounting, manual transmission	2.0 TFSI	BPJ	<b>F8-7972</b>	
Mounting, manual transmission	2.4, 2.4 quattro, 2.8 FSI, 2.8 FSI quattro, 3.0, 3.0 quattro, 3.2 FSI, 3.2 FSI quattro, 4.2 FSI quattro, 4.2 quattro		<b>F8-7972</b>	
Mounting, axle beam	2.0 TDI, 2.0 TFSI, 2.4, 2.4 quattro, 2.7 TDI, 2.7 TDI quattro, 2.8 FSI, 2.8 FSI quattro, 3.0, 3.0 quattro, 3.0 TDI, 3.0 TDI quattro, 3.0 TFSI quattro, 3.2 FSI, 3.2 FSI quattro, 4.2 FSI quattro, 4.2 quattro		<b>F8-7997</b>	
Mounting, axle beam	2.0 TDI, 2.0 TFSI, 2.4, 2.4 quattro, 2.7 TDI, 2.7 TDI quattro, 2.8 FSI, 2.8 FSI quattro, 3.0, 3.0 quattro, 3.0 TDI quattro, 3.0 TFSI quattro, 3.2 FSI, 3.2 FSI quattro, 4.2 FSI quattro, 4.2 quattro, RS6 quattro		<b>F8-8132</b>	H=80; D=58

<b>F8-7707</b>	<b>F8-7795</b>	<b>F8-7796</b>	<b>F8-7802</b>	<b>F8-7844</b>	<b>F8-7922</b>	<b>F8-7970</b>
Ref.Nr.: 4F0512131A	Ref.Nr.: 4E0407182B	Ref.Nr.: 8D0407515C	Ref.Nr.: 4B0512137B	Ref.Nr.: 4F0512131D	Ref.Nr.: 4D0411327J	Ref.Nr.: 4F0199379BL
<b>F8-7972</b>	<b>F8-7997</b>	<b>F8-8132</b>	<b>F8-8133</b>			
Ref.Nr.: 4F0399151AM	Ref.Nr.: 4F0399419E	Ref.Nr.: 4F0399415B	Ref.Nr.: 8E0505203D			

**Article Description**

**Article Nr.**
**Fitting Position**

**A6 (4F2, C6)**
**05/2004 → 03/2011**

Control Arm-/Trailing Arm Bush	2.0 TDI, 2.0 TFSI, 2.4, 2.4 quattro, 2.7 TDI, 2.7 TDI quattro, 2.8 FSI, 2.8 FSI quattro, 3.0, 3.0 quattro, 3.0 TDI, 3.0 TDI quattro, 3.0 TFSI quattro, 3.2 FSI, 3.2 FSI quattro, 4.2 FSI quattro, 4.2 quattro		<b>F8-8133</b>		H=60; d=12; D=46
Mounting, automatic transmission	4.2 FSI quattro, 4.2 quattro, RS6 quattro, S6 quattro		<b>F8-8191</b>		
Suspension Kit	2.0 TDI, 2.0 TFSI, 2.4, 2.4 quattro, 2.7 TDI, 2.7 TDI quattro, 2.8 FSI, 2.8 FSI quattro, 3.0, 3.0 quattro, 3.0 TDI, 3.0 TDI quattro, 3.0 TFSI quattro, 3.2 FSI, 3.2 FSI quattro, 4.2 FSI quattro, 4.2 quattro, RS6 quattro, S6 quattro		<b>G8-562</b>		

**A6 Allroad (4FH, C6)**
**05/2006 → 08/2011**

Alternator Freewheel Clutch	3.0 TDI quattro		<b>F5-1140</b>		
Alternator Freewheel Clutch	3.0 TFSI quattro		<b>F5-1149</b>		
Top Strut Mounting	2.7 TDI quattro, 3.0 TDI quattro, 3.2 FSI quattro, 4.2 FSI quattro		<b>F8-6352</b>		
Control Arm-/Trailing Arm Bush	All Models		<b>F8-6580</b>		d=12.1; L=80; D=65
Engine Mounting	3.2 FSI quattro	Green; with cap;	<b>F8-6743</b>		
Engine Mounting	3.2 FSI quattro	Red; with cap;	<b>F8-6745</b>		
Control Arm-/Trailing Arm Bush	All Models		<b>F8-6784</b>		H=45; d=12.2; D=43.8
Rubber Buffer, suspension	2.7 TDI quattro, 3.0 TDI quattro, 3.2 FSI quattro, 4.2 FSI quattro	for OE: 1BA;	<b>F8-7578</b>		H=146
Rubber Buffer, engine mounting	3.0 TFSI quattro, 3.2 FSI quattro, 4.2 FSI quattro		<b>F8-7599</b>		
Control Arm-/Trailing Arm Bush	All Models		<b>F8-7795</b>		
Control Arm-/Trailing Arm Bush	All Models		<b>F8-7796</b>		H=40; d=10; D=46,5
Protective Cap/Bellow, shock absorber	All Models	for OE: 1BY;	<b>F8-7802</b>		H=156
Stabiliser Mounting	2.7 TDI quattro, 3.0 TDI quattro, 3.2 FSI quattro, 4.2 FSI quattro		<b>F8-7922</b>		d=29
Engine Mounting	3.0 TDI quattro		<b>F8-7970</b>		
Mounting, axle beam	All Models		<b>F8-7997</b>		
Mounting, axle beam	All Models		<b>F8-8132</b>		H=80; D=58
Control Arm-/Trailing Arm Bush	All Models		<b>F8-8133</b>		H=60; d=12; D=46
Mounting, automatic transmission	4.2 FSI quattro		<b>F8-8191</b>		
Suspension Kit	All Models		<b>G8-562</b>		

<b>F5-1004</b>	<b>F5-1140</b>	<b>F5-1149</b>	<b>F8-6352</b>	<b>F8-6580</b>	<b>F8-6743</b>	<b>F8-6745</b>
Ref.Nr.: 038903119T	Ref.Nr.: 059903119L	Ref.Nr.: 06E903119R	Ref.Nr.: 4F0513353B	Ref.Nr.: 4F0407183C	Ref.Nr.: 4F0199379AP	Ref.Nr.: 4F0199382AQ
<b>F8-6784</b>	<b>F8-7578</b>	<b>F8-7599</b>	<b>F8-7795</b>	<b>F8-7796</b>	<b>F8-7802</b>	<b>F8-7922</b>
Ref.Nr.: 4E0407181B	Ref.Nr.: 4F0 512 131	Ref.Nr.: 8E0 199 339	Ref.Nr.: 4E0407182B	Ref.Nr.: 8D0407515C	Ref.Nr.: 4B0512137B	Ref.Nr.: 4D0411327J
<b>F8-7970</b>	<b>F8-7997</b>	<b>F8-8132</b>	<b>F8-8133</b>	<b>F8-8191</b>	<b>G8-562</b>	
Ref.Nr.: 4F0199379BL	Ref.Nr.: 4F0399419E	Ref.Nr.: 4F0399415B	Ref.Nr.: 8E0505203D	Ref.Nr.: 4F0399151AP	Ref.Nr.: 4F0498998	

**Article Description****Article Nr.****Fitting Position**

<b>A6 Avant (4F5, C6)</b>		<b>03/2005 → 08/2011</b>	
Alternator Freewheel Clutch	2.0 TDI		<b>F5-1004</b>
Alternator Freewheel Clutch	2.0 TFSI		<b>F5-1044</b>
Alternator Freewheel Clutch	2.0 TDI		<b>F5-1085</b>
Alternator Freewheel Clutch	2.7 TDI, 2.7 TDI quattro, 3.0 TDI quattro		<b>F5-1140</b>
Alternator Freewheel Clutch	2.8 FSI, 2.8 FSI quattro, 3.0 TFSI quattro		<b>F5-1149</b>
Mounting, automatic transmission	2.4, 2.4 quattro		<b>F8-5576</b>
Mounting, manual transmission	2.0 TFSI		<b>F8-5578</b>
Rubber Buffer, suspension	2.0 TDI, 2.0 TFSI, 2.4, 2.4 quattro, 2.7 TDI, 2.7 TDI quattro, 2.8 FSI, 2.8 FSI quattro, 3.0, 3.0 quattro, 3.0 TDI, 3.0 TDI quattro, 3.0 TFSI quattro, 3.2 FSI, 3.2 FSI quattro, 4.2 FSI quattro, 4.2 quattro		<b>F8-5994</b>
Top Strut Mounting	2.0 TDI, 2.0 TFSI, 2.4, 2.4 quattro, 2.7 TDI, 2.7 TDI quattro, 2.8 FSI, 2.8 FSI quattro, 3.0 quattro, 3.0 TDI, 3.0 TDI quattro, 3.0 TFSI quattro, 3.2 FSI, 3.2 FSI quattro, 4.2 FSI quattro, 4.2 quattro, S6 quattro		<b>F8-6352</b>
Belt Pulley, crankshaft	2.0 TDI	Number of Ribs: 5; Parameter: 6PK	<b>F8-6396</b>
Mounting, axle beam	2.0 TDI	BLB; Paired article nr: F8-6431	<b>F8-6430</b>
Mounting, axle beam	2.0 TDI	BNA; Paired article nr: F8-6431	<b>F8-6430</b>
Mounting, axle beam	2.4, 2.7 TDI, 3.0, 3.2 FSI	Paired article nr: F8-6431	<b>F8-6430</b>
Mounting, axle beam	2.0 TDI	BLB; Paired article nr: F8-6430	<b>F8-6431</b>
Mounting, axle beam	2.0 TDI	BNA; Paired article nr: F8-6430	<b>F8-6431</b>
Mounting, axle beam	2.4, 2.7 TDI, 3.0, 3.2 FSI	Paired article nr: F8-6430	<b>F8-6431</b>
Engine Mounting	2.0 TDI	Operating Mode: Electric	<b>F8-6534</b>
Control Arm-/Trailing Arm Bush	2.0 TDI, 2.0 TFSI, 2.4, 2.4 quattro, 2.7 TDI, 2.7 TDI quattro, 2.8 FSI, 2.8 FSI quattro, 3.0 quattro, 3.0 TDI, 3.0 TDI quattro, 3.0 TFSI quattro, 3.2 FSI, 3.2 FSI quattro, 4.2 FSI quattro, 4.2 quattro, RS6 quattro, S6 quattro		<b>F8-6580</b>
Engine Mounting	2.0 TDI	Yellow; with cap	<b>F8-6742</b>
Engine Mounting	2.0 TDI	Yellow;  BNA, BRF; with cap	<b>F8-6742</b>
Engine Mounting	2.0 TFSI	ch.4F-6-065001 →; Yellow; with cap; Transmission Type: CVT (Stepless)	<b>F8-6742</b>
Engine Mounting	2.4, 2.4 quattro, 2.8 FSI, 2.8 FSI quattro, 3.0, 3.0 quattro	Green; with cap	<b>F8-6743</b>
Engine Mounting	2.8 FSI, 2.8 FSI quattro	Green; with cap; Transmission Type: CVT (Stepless),  6-speed	<b>F8-6743</b>
Engine Mounting	3.2 FSI, 3.2 FSI quattro	ch.4F-5-087151 →; Green; with cap;  6-speed	<b>F8-6743</b>

<b>F5-1004</b>	<b>F5-1044</b>	<b>F5-1085</b>		<b>F5-1140</b>	<b>F5-1149</b>	<b>F8-5576</b>	<b>F8-5578</b>
Ref.Nr.: 038903119T	Ref.Nr.: 06B903119B	Ref.Nr.: 045903119A		Ref.Nr.: 059903119L	Ref.Nr.: 06E903119R	Ref.Nr.: 8D0399151M	Ref.Nr.: 8D0399151H
<b>F8-5994</b>	<b>F8-6352</b>	<b>F8-6396</b>	<b>F8-6430</b>	<b>F8-6431</b>	<b>F8-6534</b>	<b>F8-6580</b>	
Ref.Nr.: 8D0412131F	Ref.Nr.: 4F0513353B	Ref.Nr.: 03G105243	Ref.Nr.: 4B0501522E	Ref.Nr.: 4B0501521D	Ref.Nr.: 4F0199379AS	Ref.Nr.: 4F0407183C	
<b>F8-6742</b>	<b>F8-6743</b>						
Ref.Nr.: 4F0199382AS	Ref.Nr.: 4F0199379AP						

Article Description



Article Nr.

Fitting Position



**A6 Avant (4F5, C6)**

03/2005 → 08/2011

Engine Mounting	3.2 FSI, 3.2 FSI quattro	ch.4F-6-023321→; Green; with cap; Transmission Type: CVT (Stepless)	<b>F8-6743</b>		
Engine Mounting	2.0 TFSI	with cap	<b>F8-6744</b>		
Engine Mounting	2.4, 2.4 quattro, 3.0, 3.0 quattro	Red; with cap	<b>F8-6745</b>		
Engine Mounting	2.8 FSI, 2.8 FSI quattro	Red; with cap; Transmission Type: CVT (Stepless),  6-speed	<b>F8-6745</b>		
Engine Mounting	3.2 FSI	ch.4F-5-087151→; Red; with cap;  6-speed	<b>F8-6745</b>		
Engine Mounting	3.2 FSI, 3.2 FSI quattro	ch.4F-6-023321→; Red; with cap; Transmission Type: CVT (Stepless)	<b>F8-6745</b>		
Engine Mounting	2.0 TFSI	ch.→4F-6-065000; Violet; with cap;	<b>F8-6746</b>		
Control Arm-/Trailing Arm Bush	All Models		<b>F8-6784</b>		H=45; d=12.2; D=43.8
Top Strut Mounting	2.0 TDI, 2.0 TFSI, 2.4, 2.4 quattro, 2.7 TDI, 2.7 TDI quattro, 2.8 FSI, 2.8 FSI quattro, 3.0 quattro, 3.0 TDI, 3.0 TDI quattro, 3.0 TFSI quattro, 3.2 FSI, 3.2 FSI quattro, 4.2 FSI quattro, 4.2 quattro, RS6 quattro, S6 quattro		<b>F8-7454</b>		
Rubber Buffer, suspension	2.0 TDI, 2.0 TFSI, 2.4, 2.4 quattro, 2.7 TDI, 2.7 TDI quattro, 2.8 FSI, 2.8 FSI quattro, 3.0, 3.0 quattro, 3.0 TDI, 3.0 TDI quattro, 3.2 FSI, 3.2 FSI quattro, 4.2 FSI quattro, 4.2 quattro, S6 quattro	for OE: 1BA, 1BR;	<b>F8-7577</b>		H=94
Rubber Buffer, suspension	2.0 TDI, 2.7 TDI, 2.7 TDI quattro, 2.8 FSI, 2.8 FSI quattro, 3.0 TDI quattro, 3.0 TFSI quattro	for OE: 1BA, 1BB, 1BR;	<b>F8-7577</b>		H=94
Rubber Buffer, suspension	3.0 TFSI quattro		<b>F8-7577</b>		H=94
Rubber Buffer, suspension	2.0 TDI, 2.0 TFSI, 2.4, 2.4 quattro, 2.7 TDI, 2.7 TDI quattro, 2.8 FSI, 2.8 FSI quattro, 3.0, 3.0 quattro, 3.0 TDI, 3.0 TDI quattro, 3.2 FSI, 3.2 FSI quattro, 4.2 FSI quattro, 4.2 quattro, RS6 quattro, S6 quattro	for OE: 1BA;	<b>F8-7578</b>		H=146
Rubber Buffer, engine mounting	2.0 TDI	BLB	<b>F8-7599</b>		
Rubber Buffer, engine mounting	2.0 TDI	BNA	<b>F8-7599</b>		
Rubber Buffer, engine mounting	2.4, 2.4 quattro, 2.7 TDI, 3.0, 3.0 quattro, 3.0 TDI quattro, 3.2 FSI, 3.2 FSI quattro, 4.2 quattro		<b>F8-7599</b>		
Rubber Buffer, engine mounting	2.7 TDI	BSG	<b>F8-7599</b>		
Rubber Buffer, engine mounting	3.0 TDI quattro	BNG	<b>F8-7599</b>		
Protective Cap/Bellow, shock absorber	All Models		<b>F8-7682</b>		H=160
Protective Cap/Bellow, shock absorber	2.0 TDI, 2.0 TFSI, 2.4, 2.4 quattro, 2.7 TDI, 2.7 TDI quattro, 2.8 FSI, 2.8 FSI quattro, 3.0, 3.0 quattro, 3.0 TDI, 3.0 TDI quattro, 3.0 TFSI quattro, 3.2 FSI, 3.2 FSI quattro, 4.2 FSI quattro, 4.2 quattro, S6 quattro		<b>F8-7687</b>		H=80





**Article Description****Article Nr.****Fitting Position**

<b>A6 Avant (4F5, C6)</b>		<b>03/2005 → 08/2011</b>		
Rubber Buffer, suspension	2.0 TDI, 2.0 TFSI, 2.4, 2.4 quattro, 2.7 TDI, 2.7 TDI quattro, 2.8 FSI, 2.8 FSI quattro, 3.0, 3.0 quattro, 3.0 TDI, 3.0 TDI quattro, 3.2 FSI, 3.2 FSI quattro, 4.2 FSI quattro, 4.2 quattro, S6 quattro	<b>SP</b>	<b>F8-7707</b>	H=100
Control Arm-/Trailing Arm Bush	All Models		<b>F8-7795</b>	
Control Arm-/Trailing Arm Bush	2.0 TDI, 2.0 TFSI, 2.4, 2.4 quattro, 2.7 TDI, 2.7 TDI quattro, 2.8 FSI, 2.8 FSI quattro, 3.0, 3.0 quattro, 3.0 TDI, 3.0 TDI quattro, 3.0 TFSI quattro, 3.2 FSI, 3.2 FSI quattro		<b>F8-7796</b>	H=40; d=10; D=46,5
Control Arm-/Trailing Arm Bush	3.0 TDI quattro	BNG	<b>F8-7796</b>	H=40; d=10; D=46,5
Control Arm-/Trailing Arm Bush	3.0 TDI quattro	CDYA	<b>F8-7796</b>	H=40; d=10; D=46,5
Control Arm-/Trailing Arm Bush	4.2 FSI quattro, 4.2 quattro, RS6 quattro, S6 quattro	for OE: 1BA, 1BB, 1BE, 1BK, 1BR, 1BV, 1BY	<b>F8-7796</b>	H=40; d=10; D=46,5
Protective Cap/Bellow, shock absorber	2.0 TDI, 2.0 TFSI, 2.4, 2.4 quattro, 2.7 TDI, 2.7 TDI quattro, 2.8 FSI, 2.8 FSI quattro, 3.0, 3.0 quattro, 3.0 TDI quattro, 3.0 TFSI quattro, 3.2 FSI, 3.2 FSI quattro	for OE: 1BB, 1BR;	<b>F8-7802</b>	H=156
Protective Cap/Bellow, shock absorber	2.0 TDI, 2.0 TFSI, 2.4, 2.4 quattro, 2.7 TDI, 2.7 TDI quattro, 2.8 FSI, 2.8 FSI quattro, 3.0, 3.0 quattro, 3.0 TDI quattro, 3.0 TFSI quattro, 3.2 FSI, 3.2 FSI quattro	for OE: 1BK;	<b>F8-7802</b>	H=156
Rubber Buffer, suspension	RS6 quattro		<b>F8-7844</b>	
Rubber Buffer, suspension	S6 quattro	for OE: 1BD; <b>SP</b>	<b>F8-7844</b>	
Stabiliser Mounting	2.0 TDI, 2.0 TFSI, 2.4, 2.4 quattro, 2.7 TDI, 2.7 TDI quattro, 2.8 FSI, 2.8 FSI quattro, 3.0, 3.0 quattro, 3.0 TDI, 3.0 TDI quattro, 3.2 FSI, 3.2 FSI quattro, 4.2 FSI quattro, 4.2 quattro		<b>F8-7922</b>	d=29
Engine Mounting	3.0 TDI quattro		<b>F8-7970</b>	
Mounting, manual transmission	2.0 TDI	ch.→4F-5-200000;  BLB; Transmission Type: CVT (Stepless)	<b>F8-7972</b>	
Mounting, manual transmission	2.0 TDI	ch.→4F-5-200000;  BNA; Transmission Type: CVT (Stepless)	<b>F8-7972</b>	
Mounting, manual transmission	2.0 TFSI, 2.4, 2.4 quattro, 2.8 FSI, 2.8 FSI quattro, 3.0, 3.0 quattro, 3.2 FSI, 3.2 FSI quattro, 4.2 FSI quattro, 4.2 quattro		<b>F8-7972</b>	
Mounting, axle beam	2.0 TDI, 2.0 TFSI, 2.4, 2.4 quattro, 2.7 TDI, 2.7 TDI quattro, 2.8 FSI, 2.8 FSI quattro, 3.0, 3.0 quattro, 3.0 TDI, 3.0 TDI quattro, 3.0 TFSI quattro, 3.2 FSI, 3.2 FSI quattro, 4.2 FSI quattro, 4.2 quattro		<b>F8-7997</b>	
Mounting, axle beam	2.0 TDI, 2.0 TFSI, 2.4, 2.4 quattro, 2.7 TDI, 2.7 TDI quattro, 2.8 FSI, 2.8 FSI quattro, 3.0, 3.0 quattro, 3.0 TDI, 3.0 TDI quattro, 3.0 TFSI quattro, 3.2 FSI, 3.2 FSI quattro, 4.2 FSI quattro, 4.2 quattro, RS6 quattro		<b>F8-8132</b>	H=80; D=58

<b>F8-7707</b>	<b>F8-7795</b>	<b>F8-7796</b>	<b>F8-7802</b>	<b>F8-7844</b>	<b>F8-7922</b>	<b>F8-7970</b>
Ref.Nr.: 4F0512131A	Ref.Nr.: 4E0407182B	Ref.Nr.: 8D0407515C	Ref.Nr.: 4B0512137B	Ref.Nr.: 4F0512131D	Ref.Nr.: 4D0411327J	Ref.Nr.: 4F0199379BL
<b>F8-7972</b>	<b>F8-7997</b>	<b>F8-8132</b>	<b>F8-8133</b>			
Ref.Nr.: 4F0399151AM	Ref.Nr.: 4F0399419E	Ref.Nr.: 4F0399415B	Ref.Nr.: 8E0505203D			

Article Description



Article Nr.

Fitting Position



### A6 Avant (4F5, C6)

03/2005 → 08/2011

Control Arm-/Trailing Arm Bush	2.0 TDI, 2.0 TFSI, 2.4, 2.4 quattro, 2.7 TDI, 2.7 TDI quattro, 2.8 FSI, 2.8 FSI quattro, 3.0 quattro, 3.0 TDI, 3.0 TDI quattro, 3.0 TFSI quattro, 3.2 FSI, 3.2 FSI quattro, 4.2 FSI quattro, 4.2 quattro, RS6 quattro, S6 quattro		F8-8133		H=60; d=12; D=46
Mounting, automatic transmission	4.2 FSI quattro, 4.2 quattro, RS6 quattro, S6 quattro		F8-8191		
Suspension Kit	2.0 TDI, 2.0 TFSI, 2.4, 2.4 quattro, 2.7 TDI, 2.7 TDI quattro, 2.8 FSI, 2.8 FSI quattro, 3.0 quattro, 3.0 TDI, 3.0 TDI quattro, 3.0 TFSI quattro, 3.2 FSI, 3.2 FSI quattro, 4.2 FSI quattro, 4.2 quattro, RS6 quattro, S6 quattro		G8-562		

### A6 (4G2, C7, 4GC)

11/2010 → 04/2015

Alternator Freewheel Clutch	2.0 TDI		F5-1085		
Alternator Freewheel Clutch	3.0 TDI, 3.0 TDI quattro		F5-1140		
Belt Pulley, crankshaft	2.0 TDI	Number of Ribs: 5; Parameter: 6PK	F8-6572		
Control Arm-/Trailing Arm Bush	2.0 TDI, 2.0 TFSI, 2.0 TFSI hybrid, 2.8 FSI, 2.8 FSI quattro, 3.0 TDI, 3.0 TDI quattro, 3.0 TFSI quattro		F8-6582		
Control Arm-/Trailing Arm Bush	2.0 TDI, 2.0 TFSI, 2.0 TFSI hybrid, 2.8 FSI, 2.8 FSI quattro, 3.0 TDI, 3.0 TDI quattro, 3.0 TFSI quattro, S6 quattro		F8-6784		H=45; d=12.2; D=43.8
Top Strut Mounting	2.0 TDI, 2.8 FSI, 2.8 FSI quattro, 3.0 TDI, 3.0 TDI quattro, 3.0 TFSI quattro		F8-7451		
Protective Cap/Bellow, shock absorber	2.0 TDI, 2.0 TFSI, 2.0 TFSI hybrid, 2.8 FSI, 2.8 FSI quattro, 3.0 TDI, 3.0 TDI quattro, 3.0 TFSI quattro, S6 quattro		F8-7681		H=100
Rubber Buffer, suspension	2.0 TDI, 2.0 TFSI, 2.0 TFSI hybrid, 2.8 FSI, 2.8 FSI quattro, 3.0 TDI, 3.0 TDI quattro, 3.0 TFSI quattro	for OE: 1BA;	F8-7704		H=145
Rubber Buffer, suspension	2.0 TDI, 2.0 TFSI, 2.0 TFSI hybrid, 2.8 FSI, 2.8 FSI quattro, 3.0 TDI, 3.0 TDI quattro, 3.0 TFSI quattro, S6 quattro	for OE: 1BR;	F8-7715		H=81
Rubber Buffer, suspension	2.0 TDI, 2.0 TFSI, 2.0 TFSI hybrid, 2.8 FSI, 2.8 FSI quattro, 3.0 TDI, 3.0 TDI quattro, 3.0 TFSI quattro, S6 quattro	for OE: 1BE, 1BV;	F8-7716		H=72
Rubber Buffer, suspension	2.0 TDI, 2.0 TFSI, 2.0 TFSI hybrid, 2.8 FSI, 2.8 FSI quattro, 3.0 TDI, 3.0 TDI quattro, 3.0 TFSI quattro, S6 quattro	for OE: 1BE, 1BV;	F8-7718		H=118
Protective Cap/Bellow, shock absorber	2.0 TDI, 2.0 TFSI, 2.0 TFSI hybrid, 2.8 FSI, 2.8 FSI quattro, 3.0 TDI, 3.0 TDI quattro, 3.0 TFSI quattro	for OE: 1BR;	F8-7813		H=167
Protective Cap/Bellow, shock absorber	2.0 TDI, 2.0 TFSI, 2.0 TFSI hybrid, 2.8 FSI, 2.8 FSI quattro, 3.0 TDI, 3.0 TDI quattro, 3.0 TFSI quattro, S6 quattro	for OE: 1BK, 1BS, 2MB;	F8-7814		
Rubber Buffer, suspension	2.0 TDI, 2.0 TFSI, 2.0 TFSI hybrid, 2.8 FSI, 2.8 FSI quattro, 3.0 TDI, 3.0 TDI quattro, 3.0 TFSI quattro	for OE: 1BR;	F8-7839		H=128

<b>F5-1085</b>	<b>F5-1140</b>	<b>F8-6572</b>	<b>F8-6582</b>	<b>F8-6784</b>	<b>F8-7451</b>	<b>F8-7681</b>
Ref.Nr.: 045903119A	Ref.Nr.: 059903119L	Ref.Nr.: 038105243L	Ref.Nr.: 8K0407182A	Ref.Nr.: 4E0407181B	Ref.Nr.: 8E0412377C	Ref.Nr.: 8K0412137A
<b>F8-7704</b>	<b>F8-7715</b>	<b>F8-7716</b>	<b>F8-7718</b>	<b>F8-7813</b>	<b>F8-7814</b>	<b>F8-7839</b>
Ref.Nr.: 8K0512131H	Ref.Nr.: 8K0412131E	Ref.Nr.: 8K0412131F	Ref.Nr.: 8K0512131B	Ref.Nr.: 4G0512137A	Ref.Nr.: 8K0512137A	Ref.Nr.: 8K0512131J
<b>F8-7842</b>	<b>F8-8133</b>	<b>F8-8191</b>	<b>G8-562</b>			
Ref.Nr.: 4G0412131	Ref.Nr.: 8E0505203D	Ref.Nr.: 4F0399151AP	Ref.Nr.: 4F0498998			

**Article Description****Article Nr.****Fitting Position****A6 (4G2, C7, 4GC) 11/2010 → 04/2015**

Rubber Buffer, suspension	2.0 TDI, 2.0 TFSI, 2.0 TFSI hybrid, 2.8 FSI, 2.8 FSI quattro, 3.0 TDI, 3.0 TDI quattro, 3.0 TFSI quattro, S6 quattro	for OE: 1BA;	<b>F8-7842</b>		H=90
Rubber Buffer, suspension	2.0 TDI, 2.0 TFSI, 2.0 TFSI hybrid, 2.8 FSI, 2.8 FSI quattro, 3.0 TDI, 3.0 TDI quattro, 3.0 TFSI quattro, S6 quattro	for OE: 1BK;	<b>F8-7843</b>		H=120
Rubber Buffer, suspension	2.0 TDI, 2.0 TFSI, 2.0 TFSI hybrid, 2.8 FSI, 2.8 FSI quattro, 3.0 TDI, 3.0 TDI quattro, 3.0 TFSI quattro, S6 quattro	for OE: 1BS;	<b>F8-7843</b>		H=120
Rubber Buffer, suspension	2.0 TDI, 2.0 TFSI, 2.0 TFSI hybrid, 2.8 FSI, 2.8 FSI quattro, 3.0 TDI, 3.0 TDI quattro, 3.0 TFSI quattro, S6 quattro	for OE: 2MB;	<b>F8-7843</b>		H=120
Belt Pulley, crankshaft	2.0 TFSI, 2.0 TFSI hybrid, 2.0 TFSI quattro	Number of Ribs: 5; Parameter: 6PK	<b>F8-7880</b>		D=143
Engine Mounting	3.0 TDI, 3.0 TDI quattro		<b>F8-7970</b>		
Control Arm-/Trailing Arm Bush	2.0 TDI, 2.0 TFSI, 2.0 TFSI hybrid, 2.8 FSI, 2.8 FSI quattro, 3.0 TDI, 3.0 TDI quattro, 3.0 TFSI quattro, S6 quattro		<b>F8-8073</b>		

**A6 Allroad (4GH, 4GJ) 01/2012 →**

Alternator Freewheel Clutch	3.0 TDI quattro		<b>F5-1140</b>		
Control Arm-/Trailing Arm Bush	3.0 TDI quattro, 3.0 TFSI quattro		<b>F8-6582</b>		
Control Arm-/Trailing Arm Bush	3.0 TDI quattro, 3.0 TFSI quattro		<b>F8-6784</b>		H=45; d=12.2; D=43.8
Protective Cap/Bellow, shock absorber	3.0 TDI quattro, 3.0 TFSI quattro	for OE: 1BY;	<b>F8-7814</b>		
Rubber Buffer, suspension	3.0 TDI quattro, 3.0 TFSI quattro	for OE: 1BY;	<b>F8-7843</b>		H=120
Mounting, axle beam	3.0 TDI quattro, 3.0 TFSI quattro		<b>F8-8132</b>		H=80; D=58

**A6 Avant (4G5, C7, 4GD) 05/2011 → 04/2015**

Alternator Freewheel Clutch	2.0 TDI		<b>F5-1085</b>		
Alternator Freewheel Clutch	3.0 TDI, 3.0 TDI quattro		<b>F5-1140</b>		
Belt Pulley, crankshaft	2.0 TDI	Number of Ribs: 5; Parameter: 6PK	<b>F8-6572</b>		
Control Arm-/Trailing Arm Bush	2.0 TDI, 2.0 TFSI, 2.8 FSI, 2.8 FSI quattro, 3.0 TDI, 3.0 TDI quattro, 3.0 TFSI quattro, RS6 quattro		<b>F8-6582</b>		
Control Arm-/Trailing Arm Bush	2.0 TDI, 2.0 TFSI, 2.8 FSI, 2.8 FSI quattro, 3.0 TDI, 3.0 TDI quattro, 3.0 TFSI quattro, S6 quattro		<b>F8-6784</b>		H=45; d=12.2; D=43.8
Protective Cap/Bellow, shock absorber	2.0 TDI, 2.0 TFSI, 2.8 FSI, 2.8 FSI quattro, 3.0 TDI, 3.0 TDI quattro, 3.0 TFSI quattro, S6 quattro		<b>F8-7681</b>		H=100
Rubber Buffer, suspension	2.0 TDI, 2.0 TFSI, 2.8 FSI, 2.8 FSI quattro, 3.0 TDI, 3.0 TDI quattro, 3.0 TFSI quattro	for OE: 1BA;	<b>F8-7704</b>		H=145
Rubber Buffer, suspension	2.0 TDI, 2.0 TFSI, 2.8 FSI, 2.8 FSI quattro, 3.0 TDI, 3.0 TDI quattro, 3.0 TFSI quattro, S6 quattro	for OE: 1BR;	<b>F8-7715</b>		H=81
Rubber Buffer, suspension	2.0 TDI, 2.0 TFSI, 2.8 FSI, 2.8 FSI quattro, 3.0 TDI, 3.0 TDI quattro, 3.0 TFSI quattro, S6 quattro	for OE: 1BE, 1BV;	<b>F8-7716</b>		H=72

<b>F5-1085</b>	<b>F5-1140</b>	<b>F8-6572</b>	<b>F8-6582</b>	<b>F8-6784</b>	<b>F8-7681</b>	<b>F8-7704</b>
Ref.Nr.: 045903119A	Ref.Nr.: 059903119L	Ref.Nr.: 038105243L	Ref.Nr.: 8K0407182A	Ref.Nr.: 4E0407181B	Ref.Nr.: 8K0412137A	Ref.Nr.: 8K0512131H
<b>F8-7715</b>	<b>F8-7716</b>	<b>F8-7718</b>	<b>F8-7814</b>	<b>F8-7842</b>	<b>F8-7843</b>	<b>F8-7880</b>
Ref.Nr.: 8K0412131E	Ref.Nr.: 8K0412131F	Ref.Nr.: 8K0512131B	Ref.Nr.: 8K0512137A	Ref.Nr.: 4G0412131	Ref.Nr.: 4G0512131D	Ref.Nr.: 06H105243F
<b>F8-7970</b>	<b>F8-8073</b>	<b>F8-8132</b>				
Ref.Nr.: 4F0199379BL	Ref.Nr.: 8K0501530N	Ref.Nr.: 4F0399415B				

**Article Description**

**Article Nr.**
**Fitting Position**

**A6 Avant (4G5, C7, 4GD)**
**05/2011 → 04/2015**

Rubber Buffer, suspension	2.0 TDI, 2.0 TFSI, 2.8 FSI, 2.8 FSI quattro, 3.0 TDI, 3.0 TDI quattro, 3.0 TFSI quattro, S6 quattro	for OE: 1BE, 1BV; <b>SP</b>	<b>F8-7718</b>		H=118
Protective Cap/Bellow, shock absorber	2.0 TDI, 2.0 TFSI, 2.8 FSI, 2.8 FSI quattro, 3.0 TDI, 3.0 TDI quattro, 3.0 TFSI quattro	for OE: 1BR; <b>Δ</b>	<b>F8-7813</b>		H=167
Protective Cap/Bellow, shock absorber	2.0 TDI, 2.0 TFSI, 2.8 FSI, 2.8 FSI quattro, 3.0 TDI, 3.0 TDI quattro, 3.0 TFSI quattro, S6 quattro	for OE: 1BK, 1BS, 2MB; <b>≡</b> ; <b>↗</b>	<b>F8-7814</b>		
Rubber Buffer, suspension	2.0 TDI, 2.0 TFSI, 2.8 FSI, 2.8 FSI quattro, 3.0 TDI, 3.0 TDI quattro, 3.0 TFSI quattro	for OE: 1BR; <b>Δ</b>	<b>F8-7839</b>		H=128
Rubber Buffer, suspension	2.0 TDI, 2.0 TFSI, 2.8 FSI, 2.8 FSI quattro, 3.0 TDI, 3.0 TDI quattro, 3.0 TFSI quattro, RS6 quattro, S6 quattro	for OE: 1BA; <b>ST</b>	<b>F8-7842</b>		H=90
Rubber Buffer, suspension	2.0 TDI, 2.0 TFSI, 2.8 FSI, 2.8 FSI quattro, 3.0 TDI, 3.0 TDI quattro, 3.0 TFSI quattro, S6 quattro	for OE: 1BK; <b>≡</b> ; <b>↗</b> ; <b>ST</b>	<b>F8-7843</b>		H=120
Rubber Buffer, suspension	2.0 TDI, 2.0 TFSI, 2.8 FSI, 2.8 FSI quattro, 3.0 TDI, 3.0 TDI quattro, 3.0 TFSI quattro, S6 quattro	for OE: 1BS; <b>≡</b> ; <b>↗</b> ; <b>Δ</b>	<b>F8-7843</b>		H=120
Rubber Buffer, suspension	2.0 TDI, 2.0 TFSI, 2.8 FSI, 2.8 FSI quattro, 3.0 TDI, 3.0 TDI quattro, 3.0 TFSI quattro, S6 quattro	for OE: 2MB; <b>≡</b> ; <b>↗</b> ; <b>SP</b>	<b>F8-7843</b>		H=120
Rubber Buffer, suspension	RS6 quattro	for OE: 2MA; <b>≡</b> ; <b>↗</b>	<b>F8-7843</b>		H=120
Belt Pulley, crankshaft	2.0 TFSI	Number of Ribs: 5; Parameter: 6PK	<b>F8-7880</b>		D=143
Control Arm-/Trailing Arm Bush	2.0 TDI, 2.0 TFSI, 2.8 FSI, 2.8 FSI quattro, 3.0 TDI, 3.0 TDI quattro, 3.0 TFSI quattro, S6 quattro		<b>F8-8073</b>		
Control Arm-/Trailing Arm Bush	1.8 TFSI, 2.0 TDI, 2.0 TDI quattro, 2.0 TFSI, 2.0 TFSI quattro, 2.8 FSI, 2.8 FSI quattro, 3.0 TDI, 3.0 TDI quattro, 3.0 TFSI quattro, RS6 quattro, S6 quattro	ch.4G-D-040568, FC-D-040568-→; Prod. date →01.07.2013	<b>F8-8090</b>		

**A7 Sportback (4GA, 4GF)**
**10/2010 →**

Alternator Freewheel Clutch	3.0 TDI, 3.0 TDI quattro		<b>F5-1140</b>		
Control Arm-/Trailing Arm Bush	2.8 FSI, 2.8 FSI quattro, 3.0 TDI, 3.0 TDI quattro, 3.0 TFSI quattro, RS7 quattro		<b>F8-6582</b>		
Control Arm-/Trailing Arm Bush	2.8 FSI, 2.8 FSI quattro, 3.0 TDI, 3.0 TDI quattro, 3.0 TFSI quattro, S7 quattro		<b>F8-6784</b>		H=45; d=12.2; D=43.8
Top Strut Mounting	2.8 FSI quattro, 3.0 TDI, 3.0 TDI quattro, 3.0 TFSI quattro		<b>F8-7451</b>		
Protective Cap/Bellow, shock absorber	2.8 FSI, 2.8 FSI quattro, 3.0 TDI, 3.0 TDI quattro, 3.0 TFSI quattro		<b>F8-7681</b>		H=100
Rubber Buffer, suspension	2.8 FSI, 2.8 FSI quattro, 3.0 TDI, 3.0 TDI quattro, 3.0 TFSI quattro	for OE: 1BA; <b>ST</b>	<b>F8-7704</b>		H=145
Rubber Buffer, suspension	2.8 FSI, 2.8 FSI quattro, 3.0 TDI, 3.0 TDI quattro, 3.0 TFSI quattro	for OE: 1BA, 1BB; <b>Δ</b> , <b>ST</b>	<b>F8-7715</b>		H=81
Rubber Buffer, suspension	2.8 FSI, 2.8 FSI quattro, 3.0 TDI, 3.0 TDI quattro, 3.0 TFSI quattro	for OE: 1BE, 1BV; <b>SP</b>	<b>F8-7716</b>		H=72
Rubber Buffer, suspension	2.8 FSI, 2.8 FSI quattro, 3.0 TDI, 3.0 TDI quattro, 3.0 TFSI quattro, S7 quattro	for OE: 1BE, 1BV; <b>SP</b>	<b>F8-7718</b>		H=118
Protective Cap/Bellow, shock absorber	2.8 FSI, 2.8 FSI quattro, 3.0 TDI, 3.0 TDI quattro, 3.0 TFSI quattro	for OE: 1BB; <b>Δ</b>	<b>F8-7813</b>		H=167

<b>F5-1140</b>	<b>F8-6582</b>	<b>F8-6784</b>	<b>F8-7451</b>	<b>F8-7681</b>	<b>F8-7704</b>	<b>F8-7715</b>
Ref.Nr.: 059903119L	Ref.Nr.: 8K0407182A	Ref.Nr.: 4E0407181B	Ref.Nr.: 8E0412377C	Ref.Nr.: 8K0412137A	Ref.Nr.: 8K0512131H	Ref.Nr.: 8K0412131E
<b>F8-7716</b>	<b>F8-7718</b>	<b>F8-7813</b>	<b>F8-7814</b>	<b>F8-7839</b>	<b>F8-7842</b>	<b>F8-7843</b>
Ref.Nr.: 8K0412131F	Ref.Nr.: 8K0512131B	Ref.Nr.: 4G0512137A	Ref.Nr.: 8K0512137A	Ref.Nr.: 8K0512131J	Ref.Nr.: 4G0412131	Ref.Nr.: 4G0512131D
<b>F8-7880</b>	<b>F8-8073</b>	<b>F8-8090</b>				
Ref.Nr.: 06H105243F	Ref.Nr.: 8K0501530N	Ref.Nr.: 4H0407183B				

**Article Description****Article Nr.****Fitting Position**

<b>A7 Sportback (4GA, 4GF)</b>			<b>10/2010 →</b>		
Protective Cap/Bellow, shock absorber	2.8 FSI, 2.8 FSI quattro, 3.0 TDI, 3.0 TDI quattro, 3.0 TFSI quattro, S7 quattro	for OE: 1BK, 1BS, 2MB;	<b>F8-7814</b>		
Rubber Buffer, suspension	2.8 FSI, 2.8 FSI quattro, 3.0 TDI, 3.0 TDI quattro, 3.0 TFSI quattro	for OE: 1BB;	<b>F8-7839</b>		H=128
Rubber Buffer, suspension	2.8 FSI, 2.8 FSI quattro, 3.0 TDI, 3.0 TDI quattro, 3.0 TFSI quattro, S7 quattro	for OE: 1BK;	<b>F8-7843</b>		H=120
Rubber Buffer, suspension	2.8 FSI, 2.8 FSI quattro, 3.0 TDI, 3.0 TDI quattro, 3.0 TFSI quattro, S7 quattro	for OE: 1BS;	<b>F8-7843</b>		H=120
Rubber Buffer, suspension	2.8 FSI, 2.8 FSI quattro, 3.0 TDI, 3.0 TDI quattro, 3.0 TFSI quattro, S7 quattro	for OE: 2MB;	<b>F8-7843</b>		H=120
Rubber Buffer, suspension	RS7 quattro	for OE: 2MA;	<b>F8-7843</b>		H=120
Control Arm-/Trailing Arm Bush	2.8 FSI, 2.8 FSI quattro, 3.0 TDI, 3.0 TDI quattro, 3.0 TFSI quattro		<b>F8-8073</b>		
<b>A8 (4D2, 4D8)</b>			<b>03/1994 → 09/2002</b>		
Alternator Freewheel Clutch	2.8, 2.8 quattro		<b>F5-1043</b>		
Top Strut Mounting	2.5 TDI, 2.5 TDI quattro, 2.8, 2.8 quattro, 3.3 TDI quattro, 3.7, 3.7 quattro, 4.2 quattro, 6.0 W12 quattro, S 8 quattro		<b>F8-3050</b>		H=37; d=12; D1=72; D2=86
Control Arm-/Trailing Arm Bush	2.5 TDI quattro, 2.8 quattro, 3.7 quattro, S 8 quattro	ch.4D-S-002701→	<b>F8-4044</b>		H1=42; H2=50; d=12; D1=22; D2=40
Control Arm-/Trailing Arm Bush	2.5 TDI, 2.8	ch.4D-T-002701→	<b>F8-4044</b>		H1=42; H2=50; d=12; D1=22; D2=40
Control Arm-/Trailing Arm Bush	2.8 quattro, 4.2 quattro	ch.4D-S-002701→; 01/1995 →	<b>F8-4044</b>		H1=42; H2=50; d=12; D1=22; D2=40
Control Arm-/Trailing Arm Bush	2.8, 3.7	ch.4D-T-002701→; 01/1996 →	<b>F8-4044</b>		H1=42; H2=50; d=12; D1=22; D2=40
Control Arm-/Trailing Arm Bush	3.3 TDI quattro, 3.7, 3.7 quattro, 4.2 quattro, S 8 quattro	for OE: 4D0407151E	<b>F8-4044</b>		H1=42; H2=50; d=12; D1=22; D2=40
Control Arm-/Trailing Arm Bush	2.5 TDI, 2.5 TDI quattro, 2.8, 2.8 quattro, 3.7, 3.7 quattro, 4.2 quattro, 6.0 W12 quattro, S 8 quattro		<b>F8-4045</b>		H1=31; H2=60; d=12; D=50
Control Arm-/Trailing Arm Bush	3.3 TDI quattro, 3.7, 3.7 quattro, 4.2 quattro, S 8 quattro	for OE: 4D0407151E	<b>F8-4045</b>		H1=31; H2=60; d=12; D=50
Stabiliser Mounting	2.5 TDI quattro, 2.8 quattro		<b>F8-5063</b>		d=24.8; L=44
Stabiliser Mounting	2.5 TDI, 2.8	ch.4D-V-003001→;	<b>F8-5063</b>		d=24.8; L=44
Stabiliser Mounting	2.8	ch.4D-V-003001→; 01/1997 →;	<b>F8-5063</b>		d=24.8; L=44
Stabiliser Mounting	2.5 TDI quattro, 2.8 quattro, 3.7 quattro, 4.2 quattro, S 8 quattro		<b>F8-5064</b>		H=44; d=27
Stabiliser Mounting	2.5 TDI, 2.8	ch.4D-V-003001→	<b>F8-5064</b>		H=44; d=27
Stabiliser Mounting	2.8, 3.7	ch.4D-V-003001→; 01/1997 →	<b>F8-5064</b>		H=44; d=27
Control Arm-/Trailing Arm Bush	2.5 TDI, 2.5 TDI quattro, 2.8, 2.8 quattro, 3.3 TDI quattro, 3.7, 3.7 quattro, 4.2 quattro, 6.0 W12 quattro, S 8 quattro		<b>F8-5471</b>		

<b>F5-1043</b>	<b>F8-3050</b>	<b>F8-4044</b>	<b>F8-4045</b>	<b>F8-5063</b>	<b>F8-5064</b>	<b>F8-5471</b>
Ref.Nr.: 078903119G	Ref.Nr.: 4D0412377D	Ref.Nr.: 4D0407181H	Ref.Nr.: 4D0407182E	Ref.Nr.: 4D0411327G	Ref.Nr.: 4D0411327F	Ref.Nr.: 4D0407516C
<b>F8-6042</b>	<b>F8-7814</b>	<b>F8-7839</b>	<b>F8-7843</b>	<b>F8-8073</b>		
Ref.Nr.: 4D0412131C	Ref.Nr.: 8K0512137A	Ref.Nr.: 8K0512131J	Ref.Nr.: 4G0512131D	Ref.Nr.: 8K0501530N		

Article Description



Article Nr.

Fitting Position



### A8 (4D2, 4D8)

03/1994 → 09/2002

Rubber Buffer, suspension	2.5 TDI, 2.5 TDI quattro, 2.8, 2.8 quattro, 3.3 TDI quattro, 3.7, 3.7 quattro, 4.2 quattro, 6.0 W12 quattro		<b>F8-6042</b>		H=92
Spring Cap	2.5 TDI, 2.5 TDI quattro, 2.8, 2.8 quattro, 3.7, 3.7 quattro, 4.2 quattro, S 8 quattro	ch.4D-X-005001→; ch.→4D-X-005500	<b>F8-6283</b>		
Bellow, steering	2.5 TDI, 2.5 TDI quattro, 2.8, 2.8 quattro, 3.3 TDI quattro, 3.7, 3.7 quattro, 4.2 quattro, S 8 quattro	for vehicles with steering damper	<b>F8-7148</b>		H=141; d1=65; d2=65
Protective Cap/Bellow, shock absorber	2.5 TDI, 2.5 TDI quattro, 2.8, 2.8 quattro, 3.3 TDI quattro, 3.7, 3.7 quattro, 4.2 quattro, 6.0 W12 quattro, S 8 quattro		<b>F8-7687</b>		H=80
Control Arm-/Trailing Arm Bush	6.0 W12 quattro	<b>SP</b>	<b>F8-7796</b>		H=40; d=10; D=46,5
Control Arm-/Trailing Arm Bush	S 8 quattro		<b>F8-7796</b>		H=40; d=10; D=46,5
Suspension Kit	2.5 TDI, 2.5 TDI quattro, 2.8, 2.8 quattro, 3.3 TDI quattro, 3.7, 3.7 quattro, 4.2 quattro, 6.0 W12 quattro, S 8 quattro	ch.4D-V-004000→	<b>G8-529</b>		
Control Arm-/Trailing Arm Bush	2.5 TDI, 2.5 TDI quattro, 2.8, 2.8 quattro, 3.7, 3.7 quattro, 4.2 quattro, S 8 quattro		<b>G9-615</b>		H1=66; H2=80; d=12; D=65
Control Arm-/Trailing Arm Bush	2.5 TDI, 2.5 TDI quattro, 2.8, 2.8 quattro, 3.7, 3.7 quattro, 4.2 quattro, S 8 quattro		<b>G9-616</b>		H1=26; H2=40; d=10; D1=24; D2=46
Control Arm-/Trailing Arm Bush	3.3 TDI quattro, 3.7, 3.7 quattro, 4.2 quattro, S 8 quattro	for OE: 4D0407505B	<b>G9-616</b>		H1=26; H2=40; d=10; D1=24; D2=46
Bellow, steering	2.5 TDI, 2.5 TDI quattro, 2.8, 2.8 quattro, 3.7, 3.7 quattro, 4.2 quattro, S 8 quattro	ch.→4D-X-004999; ; with clamps; for vehicles with steering damper	<b>LM-10093S</b>		d1=64; d2=64; L [mm]=158
Bellow, steering	2.5 TDI, 2.5 TDI quattro, 2.8, 2.8 quattro, 3.7, 3.7 quattro, 4.2 quattro, S 8 quattro	ch.→4D-X-004999; ; with clamps; for vehicles with steering damper	<b>LM-10093S</b>		d1=64; d2=64; L [mm]=158
Bellow, steering	2.8, 2.8 quattro, 3.7 quattro, 4.2 quattro	; with clamps; for vehicles with steering damper	<b>LM-10093S</b>		d1=64; d2=64; L [mm]=158
Bellow, steering	2.8, 2.8 quattro, 3.7 quattro, 4.2 quattro	; with clamps; for vehicles with steering damper	<b>LM-10093S</b>		d1=64; d2=64; L [mm]=158
Bellow Set, drive shaft	2.5 TDI	with clamps	<b>MK-810160</b>		L=116

### A8 (4E )

10/2002 → 07/2010

Alternator Freewheel Clutch	2.8 FSI, 3.2 FSI, 3.2 FSI quattro, 4.2 TDI quattro		<b>F5-1140</b>		
Rubber Buffer, suspension	2.8 FSI, 3.0, 3.0 quattro, 3.0 TDI quattro, 3.2 FSI, 3.2 FSI quattro, 4.2 quattro, 4.2 TDI quattro, 6.0 W12 quattro, S8 quattro		<b>F8-5994</b>		H=85
Control Arm-/Trailing Arm Bush	All Models		<b>F8-6784</b>		H=45; d=12.2; D=43.8
Rubber Buffer, engine mounting	3.0, 3.0 quattro, 3.0 TDI quattro, 3.2 FSI, 3.2 FSI quattro		<b>F8-7599</b>		
Control Arm-/Trailing Arm Bush	All Models		<b>F8-7795</b>		
Control Arm-/Trailing Arm Bush	2.8 FSI	ch.→4E-8-014200	<b>F8-7796</b>		H=40; d=10; D=46,5

<b>F5-1140</b>	<b>F8-5994</b>	<b>F8-6042</b>	<b>F8-6283</b>	<b>F8-6784</b>	<b>F8-7148</b>	<b>F8-7599</b>
Ref.Nr.: 059903119L	Ref.Nr.: 8D0412131F	Ref.Nr.: 4D0412131C	Ref.Nr.: 8D0412065E	Ref.Nr.: 4E0407181B	Ref.Nr.: 4D0419831A	Ref.Nr.: 8E0 199 339
<b>F8-7687</b>	<b>F8-7795</b>	<b>F8-7796</b>	<b>G8-529</b>	<b>G9-615</b>	<b>G9-616</b>	<b>LM-10093S</b>
Ref.Nr.: 4D0412137B	Ref.Nr.: 4E0407182B	Ref.Nr.: 8D0407515C	Ref.Nr.: 8D0498998	Ref.Nr.: 4D0407183N	Ref.Nr.: 4D0407515	Ref.Nr.: 4D0419831A
<b>MK-810160</b>						
Ref.Nr.: 3D0 498 201						

**Article Description****Article Nr.****Fitting Position**

<b>A8 (4E_)</b>		<b>10/2002 → 07/2010</b>		
Control Arm-/Trailing Arm Bush	2.8 FSI, 3.0 quattro, 3.0 TDI quattro, 3.2 FSI, 3.2 FSI quattro, 4.2 FSI quattro, 4.2 TDI quattro, 6.0 W12 quattro, S8 quattro	for OE: 1BK, 2MA	<b>F8-7796</b>	H=40; d=10; D=46,5
Control Arm-/Trailing Arm Bush	3.0, 3.7 quattro, 4.0 TDI quattro, 4.2 quattro	ch.→4E-4-012700	<b>F8-7796</b>	H=40; d=10; D=46,5
Control Arm-/Trailing Arm Bush	3.0, 3.7 quattro, 4.0 TDI quattro, 4.2 quattro	ch.4E-4-012701→; for OE: 1BK, 2MA	<b>F8-7796</b>	H=40; d=10; D=46,5
Control Arm-/Trailing Arm Bush	3.0, 3.0 TDI quattro, 3.7 quattro, 4.2 quattro		<b>F8-8117</b>	H=80; d=12,2; D=75
Control Arm-/Trailing Arm Bush	3.2 FSI, 3.2 FSI quattro, 4.0 TDI quattro, 4.2 TDI quattro, 6.0 W12 quattro	ch.→4E-7-013420	<b>F8-8117</b>	H=80; d=12,2; D=75
<b>A8 (4H_)</b>		<b>11/2009 →</b>		
Alternator Freewheel Clutch	3.0 TDI, 3.0 TDI quattro		<b>F5-1140</b>	
Control Arm-/Trailing Arm Bush	2.0 TFSI hybrid, 3.0 TDI, 3.0 TDI quattro, 3.0 TFSI quattro, 4.0 TFSI quattro, 4.2 FSI quattro, 4.2 TDI quattro, 6.3 W12 quattro, S8 quattro		<b>F8-6784</b>	H=45; d=12,2; D=43,8
Belt Pulley, crankshaft	2.0 TFSI hybrid	Number of Ribs: 5; Parameter: 6PK	<b>F8-7880</b>	D=143
Control Arm-/Trailing Arm Bush	2.0 TFSI hybrid, 3.0 TDI, 3.0 TDI quattro, 3.0 TFSI quattro, 4.0 TFSI quattro, 4.2 FSI quattro, 4.2 TDI quattro, 6.3 W12 quattro, S8 quattro		<b>F8-8073</b>	
Mounting, stabilizer coupling rod	2.0 TFSI hybrid, 2.5 TFSI, 3.0 TDI, 3.0 TDI quattro, 3.0 TFSI quattro, 4.0 TFSI quattro, 4.2 FSI quattro, 4.2 TDI quattro, 6.3 W12 quattro, S8 quattro		<b>F8-8089</b>	
<b>ALLROAD (4BH, C5)</b>		<b>05/2000 → 08/2005</b>		
Control Arm-/Trailing Arm Bush	2.5 TDI quattro, 2.7 quattro, 2.7 T quattro	ch.→4B-3-030000	<b>F8-4045</b>	H1=31; H2=60; d=12; D=50
Control Arm-/Trailing Arm Bush	2.5 TDI quattro, 2.7 T quattro, 4.2 V8 quattro		<b>F8-5542</b>	H=40; d=10; D=46
Engine Mounting	2.5 TDI quattro		<b>F8-6530</b>	
Rubber Buffer, engine mounting	4.2 V8 quattro		<b>F8-7599</b>	
Stabiliser Mounting	2.5 TDI quattro, 2.7 T quattro, 4.2 V8 quattro		<b>F8-7922</b>	d=29
Mounting, axle beam	All Models		<b>F8-8132</b>	H=80; D=58
Bellow Set, drive shaft	2.5 TDI quattro, 2.7 T quattro, 4.2 V8 quattro	with clamps	<b>MK-810160</b>	L=116
<b>CABRIOLET (8G7, B4)</b>		<b>05/1991 → 08/2000</b>		
Dust Cover Kit, shock absorber	1.8, 1.9 TDI, 2.0 16V, 2.0 E, 2.3 E, 2.6, 2.8		<b>AK-735002</b>	
Dust Cover Kit, shock absorber	1.8, 1.9 TDI, 2.0 16V, 2.0 E, 2.3 E, 2.6, 2.8		<b>AK-735027</b>	
Top Strut Mounting	All Models		<b>F8-1027</b>	H=37; d1=14; d2=20; D=76
Mounting, axle beam	1.8, 1.9 TDI, 2.0 16V, 2.0 E, 2.3 E, 2.6, 2.8		<b>F8-1028</b>	H1=28; H2=38; d=12,2; D=41
Engine Mounting	2.3 E	ch.→8G-P-001000;	<b>F8-1032</b>	D=10; H=42; D1=38; D2=46
Anti-Friction Bearing	All Models		<b>F8-3036</b>	

<b>AK-735002</b>	<b>AK-735027</b>	<b>F5-1140</b>	<b>F8-1027</b>	<b>F8-1028</b>	<b>F8-1032</b>	<b>F8-3036</b>	
Ref.Nr.:	Ref.Nr.:	Ref.Nr.: 059903119L	Ref.Nr.: 811412323D	Ref.Nr.: 811511247	Ref.Nr.: 811199419B	Ref.Nr.: 377412335A	
<b>F8-3057</b>	<b>F8-4045</b>	<b>F8-5542</b>	<b>F8-6530</b>	<b>F8-6784</b>	<b>F8-7599</b>	<b>F8-7796</b>	
Ref.Nr.: 893407181	Ref.Nr.: 4D0407182E	Ref.Nr.: 4B0407515	Ref.Nr.: 4B0 199 379 E	Ref.Nr.: 4E0407181B	Ref.Nr.: 8E0 199 339	Ref.Nr.: 8D0407515C	
<b>F8-7880</b>	<b>F8-7922</b>	<b>F8-8073</b>	<b>F8-8089</b>	<b>F8-8117</b>	<b>F8-8132</b>	<b>MK-810160</b>	
Ref.Nr.: 06H105243F	Ref.Nr.: 4D0411327J	Ref.Nr.: 8K0501530N	Ref.Nr.: 4H6411317A	Ref.Nr.: 4E0407183H	Ref.Nr.: 4F0399415B	Ref.Nr.: 3D0 498 201	

Article Description



Article Nr.

Fitting Position



**CABRIOLET (8G7, B4)**

05/1991 → 08/2000

Control Arm-/Trailing Arm Bush	2.3 E	ch.→8GN001533	<b>F8-3057</b>		H=44; d=10; D1=44; D2=54
Control Arm-/Trailing Arm Bush	2.6, 2.8	ch.→8G-R-003924	<b>F8-3057</b>		H=44; d=10; D1=44; D2=54
Mounting, radiator	2.3 E		<b>F8-4009</b>		H1=15; H2=37; D=39; Outer Thread [mm]=M8 x 1,50
Engine Mounting	1.8, 2.0 16V, 2.0 E, 2.6, 2.8		<b>F8-4019</b>		H=47; d=26; D1=48; D2=67
Rubber Buffer, engine mounting	1.9 TDI		<b>F8-4020</b>		H=47; d=26; D1=47; D2=70
Clamp, silencer	1.8, 1.9 TDI, 2.0 16V, 2.0 E, 2.3 E		<b>F8-4027</b>		H=17; W=53, 61
Mounting, automatic transmission	1.8		<b>F8-4028</b>		H=42; D=11; D1=50; D2=80; T [mm]=94
Mounting, automatic transmission	1.9 TDI, 2.0 E		<b>F8-4028</b>		H=42; D=11; D1=50; D2=80; T [mm]=94
Mounting, automatic transmission	2.0 16V		<b>F8-4028</b>		H=42; D=11; D1=50; D2=80; T [mm]=94
Control Arm-/Trailing Arm Bush	1.8, 1.9 TDI, 2.0 16V, 2.0 E	ch.8G-N-001534→	<b>F8-4043</b>		H=44; d=10; D1=37; D2=54
Control Arm-/Trailing Arm Bush	2.3 E	ch.8G-N-001534→; 01/1992 →	<b>F8-4043</b>		H=44; d=10; D1=37; D2=54
Control Arm-/Trailing Arm Bush	2.6		<b>F8-4043</b>		H=44; d=10; D1=37; D2=54
Control Arm-/Trailing Arm Bush	2.6, 2.8	ch.8G-R-003925→; 01/1994 →	<b>F8-4043</b>		H=44; d=10; D1=37; D2=54
Bellow, steering	All Models		<b>F8-4073</b>		H=147; D=48
Engine Mounting	1.8, 1.9 TDI, 2.0 16V, 2.0 E		<b>F8-5527</b>		d=12; L=42; D=38
Engine Mounting	2.3 E	ch.8G-P-001001→; 01/1993 →	<b>F8-5527</b>		d=12; L=42; D=38
Engine Mounting	1.9 TDI	ch.8C-P-050246→	<b>F8-5528</b>		d=12; D=39; Thick. [mm]=46
Engine Mounting	2.0 16V, 2.8	ch.8C-P-244764→	<b>F8-5528</b>		d=12; D=39; Thick. [mm]=46
Engine Mounting	2.0 E	ch.8C-N-190001, 8C-P-244764→	<b>F8-5528</b>		d=12; D=39; Thick. [mm]=46
Engine Mounting	2.3 E	ch.8C-P-050246, 8G-P-001001→	<b>F8-5528</b>		d=12; D=39; Thick. [mm]=46
Engine Mounting	2.6	ch.8C-P-053246, 8C-P-244764→	<b>F8-5528</b>		d=12; D=39; Thick. [mm]=46
Engine Mounting	2.6	ch.8C-P-053246, 8G-P-001001→	<b>F8-5528</b>		d=12; D=39; Thick. [mm]=46
Engine Mounting	1.8, 1.9 TDI, 2.0 16V, 2.0 E		<b>F8-5529</b>		
Belt Pulley, crankshaft	1.9 TDI	Number of Ribs: 5; Parameter: 6PK	<b>F8-5649</b>		H=31.5; d=30.02; Mounting points diam.[mm]=8.5; D1=161.5; D2=160.5
Engine Mounting	2.6, 2.8	Number of Cylinders: 6	<b>F8-5934</b>		
Engine Mounting	2.0 16V, 2.0 E, 2.3 E		<b>F8-6212</b>		
Engine Mounting	1.9 TDI, 2.0 16V, 2.0 E		<b>F8-6241</b>		
Engine Mounting	2.3 E	Blue;	<b>F8-6748</b>		





**Article Description****Article Nr.****Fitting Position**

<b>CABRIOLET (8G7, B4)</b>				<b>05/1991 → 08/2000</b>	
Engine Mounting	2.3 E	Green;	<b>F8-6749</b>		
Engine Mounting	2.3 E	Brown;	<b>F8-6750</b>		
Engine Mounting	2.3 E	White;	<b>F8-6751</b>		
Engine Mounting	1.8, 1.9 TDI, 2.0 16V, 2.0 E		<b>F8-8180</b>		
Bellow, steering	All Models	with clamps	<b>LM-10026S</b>		d1=27; d2=45; L [mm]=150
<b>COUPE (81, 85)</b>				<b>07/1980 → 10/1988</b>	
Dust Cover Kit, shock absorber	1.6, 1.8, 1.8 GT, 1.9, 2.0, 2.1 GT, 2.2 GT, 2.2 quattro, 2.3		<b>AK-735002</b>		
Dust Cover Kit, shock absorber	1.6, 1.8, 1.8 GT, 1.9, 2.0, 2.1 GT, 2.2 GT, 2.3		<b>AK-735006</b>		
Dust Cover Kit, shock absorber	1.6, 1.8, 1.8 GT, 1.9, 2.0, 2.1 GT, 2.2 GT, 2.3		<b>AK-735027</b>		
Dust Cover Kit, shock absorber	1.6, 1.8, 1.8 GT, 1.9, 2.0, 2.1 GT, 2.2 GT, 2.2 quattro, 2.3, 2.3 quattro		<b>AK-735098</b>		
Engine Mounting	1.9, 2.1 GT, 2.2 GT		<b>F8-1020</b>		H=97; D=114; τ [mm]=145
Engine Mounting	2.0	01/1985 →;	<b>F8-1020</b>		H=97; D=114; τ [mm]=145
Engine Mounting	2.0		<b>F8-1020</b>		H=97; D=114; τ [mm]=145
Engine Mounting	2.0		<b>F8-1020</b>		H=97; D=114; τ [mm]=145
Engine Mounting	2.2 GT	ch.85-F-150001 →;	<b>F8-1020</b>		H=97; D=114; τ [mm]=145
Engine Mounting	2.2 GT, 2.3		<b>F8-1020</b>		H=97; D=114; τ [mm]=145
Engine Mounting	2.2 quattro, 2.3 quattro		<b>F8-1020</b>		H=97; D=114; τ [mm]=145
Engine Mounting	2.0, 2.2 GT	ch.85-F-150001 →; 01/1985 →;	<b>F8-1021</b>		H=97; D=114; τ [mm]=143
Engine Mounting	2.2 quattro, 2.3 quattro		<b>F8-1021</b>		H=97; D=114; τ [mm]=143
Engine Mounting	2.3	ch.85-F-150001 →;	<b>F8-1021</b>		H=97; D=114; τ [mm]=143
Control Arm-/Trailing Arm Bush	1.6, 1.8 GT		<b>F8-1026</b>		H=44; d=10; D1=38; D2=48
Control Arm-/Trailing Arm Bush	1.8, 1.8 GT, 1.9, 2.1 GT, 2.2 GT	ch.→85-D-079180	<b>F8-1026</b>		H=44; d=10; D1=38; D2=48
Top Strut Mounting	1.6, 1.8, 1.8 GT, 1.9, 2.0, 2.1 GT, 2.2 GT, 2.2 quattro, 2.3, 2.3 quattro		<b>F8-1027</b>		H=37; d1=14; d2=20; D=76
Mounting, axle beam	1.8, 1.8 GT, 1.9, 2.0, 2.1 GT, 2.2 GT, 2.3		<b>F8-1028</b>		H1=28; H2=38; d=12.2; D=41
Stabiliser Mounting	1.8 GT, 2.2 GT, 2.3		<b>F8-1029</b>		H=42; Thick. [mm]=25; W=38
Engine Mounting	1.8 GT		<b>F8-1031</b>		H=47; d=10; D1=36; D2=52
Engine Mounting	1.8 GT, 2.0, 2.2 GT, 2.3	ch.85-G-060581 →; ch.→8B-P-001000	<b>F8-1032</b>		D=10; H=42; D1=38; D2=46
Engine Mounting	1.8, 1.8 GT		<b>F8-3000</b>		H=60; Thick. [mm]=66; W=89
Anti-Friction Bearing	All Models		<b>F8-3036</b>		
Flange, carburettor	1.8 GT	01/1983 →	<b>F8-3044</b>		H=21
Flange, carburettor	1.8 GT		<b>F8-3045</b>		H=21
Flange, carburettor	1.8 GT		<b>F8-3047</b>		H=24



Article Description			Article Nr.	Fitting Position	
<b>COUPE (81, 85)</b>					<b>07/1980 → 10/1988</b>
Mounting, radiator	1.6, 1.8	for hot climate zones; ☼	<b>F8-4009</b>		H1=15; H2=37; D=39; Outer Thread [mm]=M8 x 1,50
Mounting, radiator	1.8 GT	ch.→85-F-045000;  DS	<b>F8-4009</b>		H1=15; H2=37; D=39; Outer Thread [mm]=M8 x 1,50
Mounting, radiator	1.9, 2.0, 2.1 GT, 2.2 GT, 2.2 quattro, 2.3, 2.3 quattro		<b>F8-4009</b>		H1=15; H2=37; D=39; Outer Thread [mm]=M8 x 1,50
Mounting, radiator	2.1 GT	KE	<b>F8-4009</b>		H1=15; H2=37; D=39; Outer Thread [mm]=M8 x 1,50
Mounting, radiator	1.8, 1.9, 2.0, 2.1 GT, 2.2 GT, 2.2 quattro, 2.3, 2.3 quattro		<b>F8-4011</b>		H1=16; H2=38; D=30; Outer Thread [mm]=M8 x 1,25
Rubber Buffer, silencer	1.8 GT, 2.2 GT		<b>F8-4026</b>		H=12; W=57, 60
Clamp, silencer	2.2 quattro, 2.3 quattro		<b>F8-4027</b>		H=17; W=53, 61
Mounting, automatic transmission	2.2 quattro		<b>F8-4028</b>		H=42; D=11; D1=50; D2=80; T [mm]=94
Mounting, automatic transmission	2.2 quattro, 2.3 quattro		<b>F8-4028</b>		H=42; D=11; D1=50; D2=80; T [mm]=94
Mounting, manual transmission	1.8, 1.8 GT		<b>F8-4030</b>		H=50; d=14; D=84
Control Arm-/Trailing Arm Bush	1.8, 1.8 GT, 1.9, 2.0, 2.1 GT, 2.2 quattro, 2.3 quattro		<b>F8-4043</b>		H=44; d=10; D1=37; D2=54
Control Arm-/Trailing Arm Bush	2.2 GT, 2.3	ch.85-D-079181→	<b>F8-4043</b>		H=44; d=10; D1=37; D2=54
Control Arm-/Trailing Arm Bush	2.2 quattro	01/1985 →	<b>F8-4043</b>		H=44; d=10; D1=37; D2=54
Rubber Buffer, suspension	1.6, 1.8, 1.8 GT, 1.9, 2.0, 2.1 GT, 2.2 GT, 2.2 quattro, 2.3, 2.3 quattro		<b>F8-4062</b>		H=67; d1=20; d2=24; D=52
Protective Cap/Bellow, shock absorber	1.8, 1.8 GT, 1.9, 2.0, 2.2 GT, 2.2 quattro		<b>F8-4065</b>		H=97; d1=46; d2=76
Bellow, steering	1.6, 1.8, 1.8 GT, 1.9, 2.0, 2.1 GT, 2.2 GT, 2.2 quattro, 2.3, 2.3 quattro		<b>F8-4073</b>		H=147; D=48
Rubber Buffer, suspension	1.6, 1.8, 1.8 GT, 1.9, 2.0, 2.1 GT, 2.2 GT, 2.3		<b>F8-4085</b>		H=84; d1=11; d2=15; D1=35; D2=48
Suspension, panhard rod	1.8, 1.8 GT, 1.9, 2.0, 2.1 GT, 2.2 GT, 2.3		<b>F8-5344</b>		d=12.2
Engine Mounting	2.3		<b>F8-5528</b>		d=12; D=39; Thick. [mm]=46
Engine Mounting	1.6, 1.8, 1.8 GT, 1.9, 2.0, 2.1 GT, 2.2 GT		<b>F8-5685</b>		H=36; d=10; D=40.5
Bellow, steering	All Models	with clamps	<b>LM-10026S</b>		d1=27; d2=45; L [mm]=150
<b>COUPE (89, 8B)</b>					<b>10/1988 → 12/1996</b>
Dust Cover Kit, shock absorber	1.8, 2.0, 2.0 16 V, 2.0 20 V quattro, 2.2 quattro, 2.3, 2.3 20V, 2.3 20V quattro, 2.3 quattro, 2.6, 2.6 quattro, 2.8, 2.8 quattro, S2 quattro		<b>AK-735002</b>		
Dust Cover Kit, shock absorber	1.8, 2.0, 2.0 16 V, 2.0 20 V quattro, 2.2 quattro, 2.3, 2.3 20V, 2.3 20V quattro, 2.3 quattro, 2.6, 2.6 quattro, 2.8, 2.8 quattro		<b>AK-735027</b>		

<b>AK-735002</b>	<b>AK-735027</b>	<b>AK-735098</b>	<b>F8-4009</b>	<b>F8-4011</b>	<b>F8-4026</b>	<b>F8-4027</b>
Ref.Nr.:	Ref.Nr.:	Ref.Nr.:	Ref.Nr.: 431121273	Ref.Nr.: 803121273	Ref.Nr.: 817253147	Ref.Nr.: 171253147A
<b>F8-4028</b>	<b>F8-4030</b>	<b>F8-4043</b>	<b>F8-4062</b>	<b>F8-4065</b>	<b>F8-4073</b>	<b>F8-4085</b>
Ref.Nr.: 431399151D	Ref.Nr.: 811399151B	Ref.Nr.: 8A0407181	Ref.Nr.: 811412131A	Ref.Nr.: 811412135A	Ref.Nr.: 811419831B	Ref.Nr.: 811512131
<b>F8-5344</b>	<b>F8-5528</b>	<b>F8-5685</b>	<b>LM-10026S</b>			
Ref.Nr.: 431505172	Ref.Nr.: 8A0199415C	Ref.Nr.: 811199419A	Ref.Nr.: 811419831B			

**Article Description****Article Nr.****Fitting Position**

<b>COUPE (89, 8B)</b>			<b>10/1988 → 12/1996</b>		
Dust Cover Kit, shock absorber	1.8, 2.0, 2.0 16 V, 2.0 20 V, 2.0 20 V quattro, 2.2 quattro, 2.3, 2.3 20V, 2.3 20V quattro, 2.3 quattro, 2.6, 2.8		<b>AK-735098</b>		
Engine Mounting	2.3, 2.3 20V, 2.3 20V quattro		<b>F8-1020</b>		H=97; D=114; T [mm]=145
Engine Mounting	S2 quattro		<b>F8-1020</b>		H=97; D=114; T [mm]=145
Engine Mounting	2.2 quattro, 2.3 20V quattro, 2.3 quattro, S2 quattro		<b>F8-1021</b>		H=97; D=114; T [mm]=143
Top Strut Mounting	1.8, 2.0, 2.0 16 V, 2.0 20 V, 2.0 20 V quattro, 2.2 quattro, 2.3, 2.3 20V, 2.3 20V quattro, 2.3 quattro, 2.6, 2.6 quattro, 2.8, 2.8 quattro, S2 quattro		<b>F8-1027</b>		H=37; d1=14; d2=20; D=76
Mounting, axle beam	1.8, 2.0, 2.0 16 V, 2.3, 2.3 20V, 2.6, 2.8		<b>F8-1028</b>		H1=28; H2=38; d=12,2; D=41
Engine Mounting	1.8, 2.0, 2.8		<b>F8-1031</b>		H=47; d=10; D1=36; D2=52
Engine Mounting	1.8, 2.0, 2.0 16 V, 2.3, 2.3 20V, 2.6, 2.8	ch.85-G-060581→; ch.→8B-P-001000	<b>F8-1032</b>		D=10; H=42; D1=38; D2=46
Engine Mounting	2.0		<b>F8-3000</b>		H=60; Thick. [mm]=66; W=89
Anti-Friction Bearing	All Models		<b>F8-3036</b>		
Control Arm-/Trailing Arm Bush	2.8	ch.8B-N-000256→; ch.→8B-N-009191	<b>F8-3057</b>		H=44; d=10; D1=44; D2=54
Control Arm-/Trailing Arm Bush	S2 quattro		<b>F8-3057</b>		H=44; d=10; D1=44; D2=54
Mounting, radiator	1.8, 2.0	for hot climate zones;	<b>F8-4009</b>		H1=15; H2=37; D=39; Outer Thread [mm]=M8 x 1,50
Mounting, radiator	2.0 20 V quattro, 2.2 quattro, 2.3 20V quattro, 2.3 quattro		<b>F8-4009</b>		H1=15; H2=37; D=39; Outer Thread [mm]=M8 x 1,50
Mounting, radiator	2.0 20 V, 2.3, 2.3 20V	ch.→8B-L-027000;	<b>F8-4009</b>		H1=15; H2=37; D=39; Outer Thread [mm]=M8 x 1,50
Mounting, radiator	2.0 20 V, 2.3, 2.3 20V	ch.8B-L-027001→;	<b>F8-4009</b>		H1=15; H2=37; D=39; Outer Thread [mm]=M8 x 1,50
Mounting, radiator	1.8, 2.0, 2.2 quattro, 2.3, 2.3 20V, 2.3 20V quattro, 2.3 quattro, 2.6 quattro, 2.8 quattro, S2 quattro		<b>F8-4011</b>		H1=16; H2=38; D=30; Outer Thread [mm]=M8 x 1,25
Engine Mounting	1.8, 2.0, 2.0 16 V, 2.6, 2.6 quattro, 2.8, 2.8 quattro		<b>F8-4019</b>		H=47; d=26; D1=48; D2=67
Engine Mounting	2.2 quattro, 2.3, 2.3 20V, 2.3 20V quattro, 2.3 quattro		<b>F8-4021</b>		H=96; D=114; T [mm]=146
Clamp, silencer	1.8, 2.0, 2.0 16 V, 2.0 20 V quattro, 2.2 quattro, 2.3, 2.3 20V, 2.3 20V quattro, 2.3 quattro, 2.6, 2.6 quattro, 2.8, 2.8 quattro, S2 quattro		<b>F8-4027</b>		H=17; W=53, 61
Mounting, automatic transmission	1.8, 2.0		<b>F8-4028</b>		H=42; D=11; D1=50; D2=80; T [mm]=94
Mounting, automatic transmission	2.0 16 V, 2.3 20V quattro		<b>F8-4028</b>		H=42; D=11; D1=50; D2=80; T [mm]=94
Mounting, automatic transmission	2.2 quattro, 2.3 quattro		<b>F8-4028</b>		H=42; D=11; D1=50; D2=80; T [mm]=94
Control Arm-/Trailing Arm Bush	1.8, 2.0, 2.0 16 V, 2.0 20 V quattro, 2.2 quattro, 2.3, 2.3 20V, 2.3 20V quattro, 2.3 quattro, 2.6 quattro, 2.8 quattro, S2 quattro		<b>F8-4043</b>		H=44; d=10; D1=37; D2=54

<b>AK-735098</b>	<b>F8-1020</b>	<b>F8-1021</b>	<b>F8-1027</b>	<b>F8-1028</b>	<b>F8-1031</b>	<b>F8-1032</b>
Ref.Nr.:	Ref.Nr.: 443199379	Ref.Nr.: 443199382	Ref.Nr.: 811412323D	Ref.Nr.: 811511247	Ref.Nr.: 811199415A	Ref.Nr.: 811199419B
<b>F8-3000</b>	<b>F8-3036</b>	<b>F8-3057</b>	<b>F8-4009</b>	<b>F8-4011</b>	<b>F8-4019</b>	<b>F8-4021</b>
Ref.Nr.: 823199381B	Ref.Nr.: 377412335A	Ref.Nr.: 893407181	Ref.Nr.: 431121273	Ref.Nr.: 803121273	Ref.Nr.: 893199339	Ref.Nr.: 443199379E
<b>F8-4027</b>	<b>F8-4028</b>	<b>F8-4043</b>				
Ref.Nr.: 171253147A	Ref.Nr.: 431399151D	Ref.Nr.: 8A0407181				

**Article Description**

**Article Nr.**
**Fitting Position**

**COUPE (89, 8B)**
**10/1988 → 12/1996**

Control Arm-/Trailing Arm Bush	2.6	ch.8B-N-009192→	<b>F8-4043</b>		H=44; d=10; D1=37; D2=54
Control Arm-/Trailing Arm Bush	2.8	ch.8B-N-009192→; 01/1992 →	<b>F8-4043</b>		H=44; d=10; D1=37; D2=54
Rubber Buffer, suspension	2.0 20 V quattro		<b>F8-4062</b>		H=67; d1=20; d2=24; D=52
Rubber Buffer, suspension	2.2 quattro, 2.3 20V quattro, 2.3 quattro	ch.→8B-M-020000	<b>F8-4062</b>		H=67; d1=20; d2=24; D=52
Protective Cap/Bellow, shock absorber	2.2 quattro, 2.3, 2.3 20V, 2.3 20V quattro		<b>F8-4065</b>		H=97; d1=46; d2=76
Bellow, steering	1.8, 2.0, 2.0 16 V, 2.0 20 V quattro, 2.2 quattro, 2.3, 2.3 20V, 2.3 20V quattro, 2.3 quattro, 2.6, 2.6 quattro, 2.8, 2.8 quattro, S2 quattro		<b>F8-4073</b>		H=147; D=48
Suspension, panhard rod	1.8, 2.0, 2.0 16 V, 2.3, 2.3 20V, 2.6, 2.8		<b>F8-5344</b>		d=12.2
Engine Mounting	2.0 16 V, 2.3	ch.8B-P-001001→	<b>F8-5527</b>		d=12; L=42; D=38
Engine Mounting	2.0 16 V, 2.3		<b>F8-5528</b>		d=12; D=39; Thick. [mm]=46
Engine Mounting	2.3, 2.6, 2.8	ch.8B-N-024001→	<b>F8-5528</b>		d=12; D=39; Thick. [mm]=46
Engine Mounting	2.6 quattro	ch.8B-P-009001→	<b>F8-5528</b>		d=12; D=39; Thick. [mm]=46
Engine Mounting	2.8 quattro	ch.8B-P-009001, 8C-P-050246→	<b>F8-5528</b>		d=12; D=39; Thick. [mm]=46
Engine Mounting	2.0	ch.8B-N-000001→;  ABK;	<b>F8-5529</b>		
Engine Mounting	2.0 16 V		<b>F8-5529</b>		
Engine Mounting	2.6, 2.6 quattro, 2.8, 2.8 quattro	ch.8B-P-000001→	<b>F8-5934</b>		
Engine Mounting	2.0, 2.0 16 V, 2.0 20 V, 2.3, 2.3 20V		<b>F8-6212</b>		
Engine Mounting	2.0, 2.0 16 V		<b>F8-6241</b>		
Engine Mounting	2.3	ch.8B-N-000001→; Blue;	<b>F8-6748</b>		
Engine Mounting	2.0 20 V quattro, 2.2 quattro, 2.3 20V quattro, 2.3 quattro, S2 quattro	ch.8B-N-000001→; Green;	<b>F8-6749</b>		
Engine Mounting	2.3	ch.8B-N-000001→; Green;	<b>F8-6749</b>		
Engine Mounting	2.0 20 V quattro, 2.2 quattro, 2.3, 2.3 20V quattro, 2.3 quattro, S2 quattro	ch.8B-N-000001→; Brown;	<b>F8-6750</b>		
Engine Mounting	2.0 20 V quattro, 2.2 quattro, 2.3, 2.3 20V quattro, 2.3 quattro, S2 quattro	ch.8B-N-000001→; White;	<b>F8-6751</b>		
Engine Mounting	2.0	ch.8B-N-000001→;  ABK;	<b>F8-8180</b>		
Engine Mounting	2.0 16 V		<b>F8-8180</b>		
Bellow, steering	All Models	with clamps	<b>LM-10026S</b>		d1=27; d2=45; L [mm]=150

**Q3 (8U)**
**06/2011 →**

Alternator Freewheel Clutch	2.0 TDI, 2.0 TDI quattro		<b>F5-1004</b>		
Control Arm-/Trailing Arm Bush	2.0 TDI, 2.0 TDI quattro, 2.0 TFSI quattro		<b>F8-5633</b>		
Protective Cap/Bellow, shock absorber	2.0 TDI, 2.0 TDI quattro, 2.0 TFSI quattro	for OE: 1JT;	<b>F8-6044</b>		H=160

<b>F5-1004</b>	<b>F8-4043</b>	<b>F8-4062</b>	<b>F8-4065</b>	<b>F8-4073</b>	<b>F8-5344</b>	<b>F8-5527</b>
Ref.Nr.: 038903119T	Ref.Nr.: 8A0407181	Ref.Nr.: 811412131A	Ref.Nr.: 811412135A	Ref.Nr.: 811419831B	Ref.Nr.: 431505172	Ref.Nr.: 8A0199419
<b>F8-5528</b>	<b>F8-5529</b>	<b>F8-5633</b>	<b>F8-5934</b>	<b>F8-6044</b>	<b>F8-6212</b>	<b>F8-6241</b>
Ref.Nr.: 8A0199415C	Ref.Nr.: 8A0199379E	Ref.Nr.: 1K0407182A	Ref.Nr.: 8A0199419A	Ref.Nr.: 3C0513425	Ref.Nr.: 893399151	Ref.Nr.: 8A0199382A
<b>F8-6748</b>	<b>F8-6749</b>	<b>F8-6750</b>	<b>F8-6751</b>	<b>F8-8180</b>	<b>LM-10026S</b>	
Ref.Nr.: 8A0199379C	Ref.Nr.: 8A0199381	Ref.Nr.: 8A0199382C	Ref.Nr.: 8A0199382D	Ref.Nr.: 8A0199382B	Ref.Nr.: 811419831B	

**Article Description****Article Nr.****Fitting Position**

<b>Q3 (8U)</b>			<b>06/2011 →</b>		
Protective Cap/Bellow, shock absorber	2.0 TDI, 2.0 TDI quattro, 2.0 TFSI quattro	for OE: UA0, UA1; <b>SP</b> , <b>ST</b>	<b>F8-6044</b>		H=160
Protective Cap/Bellow, shock absorber	2.0 TDI, 2.0 TDI quattro, 2.0 TFSI quattro	S line; for OE: UC3; <b>SP</b>	<b>F8-6044</b>		H=160
Top Strut Mounting	2.0 TDI, 2.0 TDI quattro, 2.0 TFSI quattro, RS 2.5 quattro		<b>F8-6284</b>		
Anti-Friction Bearing	2.0 TDI, 2.0 TDI quattro, 2.0 TFSI quattro		<b>F8-6569</b>		
Top Strut Mounting	2.0 TDI, 2.0 TDI quattro, 2.0 TFSI quattro	for OE: G05, G09, G11;	<b>F8-6570</b>		
Belt Pulley, crankshaft	2.0 TDI, 2.0 TDI quattro	Number of Ribs: 5; Parameter: 6PK	<b>F8-6572</b>		
Protective Cap/Bellow, shock absorber	2.0 TDI, 2.0 TDI quattro, 2.0 TFSI quattro		<b>F8-7132</b>		H=190
Top Strut Mounting	2.0 TDI, 2.0 TDI quattro, 2.0 TFSI quattro, RS 2.5 quattro		<b>F8-7603</b>		
Rubber Buffer, suspension	2.0 TDI, 2.0 TDI quattro, 2.0 TFSI quattro	for OE: UA0; <b>ST</b>	<b>F8-7836</b>		H=143
Rubber Buffer, suspension	2.0 TDI, 2.0 TDI quattro, 2.0 TFSI quattro	for OE: UA1; <b>SP</b>	<b>F8-7836</b>		H=143
Belt Pulley, crankshaft	2.0 TFSI quattro	Number of Ribs: 5; Parameter: 6PK	<b>F8-7880</b>		D=143
Control Arm-/Trailing Arm Bush	1.4 TFSI, 2.0 TDI, 2.0 TDI quattro, 2.0 TFSI quattro		<b>F8-7909</b>		
Engine Mounting	1.4 TFSI, 2.0 TDI, 2.0 TDI quattro, 2.0 TFSI quattro, RS 2.5 quattro		<b>F8-7982</b>		
Engine Mounting	2.0 TDI	CFFB	<b>F8-7982</b>		
Control Arm-/Trailing Arm Bush	2.0 TDI, 2.0 TDI quattro, 2.0 TFSI quattro, RS 2.5 quattro		<b>F8-7991</b>		
<b>Q5 (8R)</b>			<b>11/2008 →</b>		
Dust Cover Kit, shock absorber	2.0 TDI, 2.0 TDI quattro, 2.0 TFSI hybrid quattro, 2.0 TFSI quattro, 3.0 TDI quattro, 3.0 TFSI quattro, 3.2 FSI quattro	for OE: 1BA, 1BV; <b>SP</b> , <b>ST</b>	<b>AK-735449</b>		
Dust Cover Kit, shock absorber	SQ5 quattro	for OE: 2MT; <b>ST</b>	<b>AK-735449</b>		
Dust Cover Kit, shock absorber	2.0 TDI, 2.0 TDI quattro, 2.0 TFSI quattro, 3.0 TDI quattro, 3.2 FSI quattro	for OE: 1BA, 1BV;	<b>AK-735450</b>		
Alternator Freewheel Clutch	2.0 TDI, 2.0 TDI quattro		<b>F5-1085</b>		
Alternator Freewheel Clutch	3.0 TDI quattro, SQ5 quattro		<b>F5-1140</b>		
Alternator Freewheel Clutch	3.2 FSI quattro		<b>F5-1146</b>		
Belt Pulley, crankshaft	2.0 TDI quattro	Number of Ribs: 5; Parameter: 6PK	<b>F8-6396</b>		H=41.6; d=30; Mounting points diam.[mm]=7, 8.6; D=139.7
Belt Pulley, crankshaft	2.0 TDI	Number of Ribs: 5; Parameter: 6PK	<b>F8-6572</b>		
Belt Pulley, crankshaft	2.0 TDI quattro	CGLA; Number of Ribs: 5; Parameter: 6PK	<b>F8-6572</b>		
Belt Pulley, crankshaft	2.0 TDI quattro	CGLB, CMGA; Number of Ribs: 5; Parameter: 6PK	<b>F8-6572</b>		

<b>AK-735449</b>	<b>AK-735450</b>	<b>F5-1085</b>	<b>F5-1140</b>	<b>F5-1146</b>	<b>F8-6044</b>	<b>F8-6284</b>
Ref.Nr.: 8K0412137A	Ref.Nr.: 4B0512137B	Ref.Nr.: 045903119A	Ref.Nr.: 059903119L	Ref.Nr.: 06E903119Q	Ref.Nr.: 3C0513425	Ref.Nr.: 6N0412249C
<b>F8-6396</b>	<b>F8-6569</b>	<b>F8-6570</b>	<b>F8-6572</b>	<b>F8-7132</b>	<b>F8-7603</b>	<b>F8-7836</b>
Ref.Nr.: 03G105243	Ref.Nr.: 6N0412249C	Ref.Nr.: 1K0412331C	Ref.Nr.: 038105243L	Ref.Nr.: 6N0413175A	Ref.Nr.: 3C0513353	Ref.Nr.: 1T0511359
<b>F8-7880</b>	<b>F8-7909</b>	<b>F8-7982</b>	<b>F8-7991</b>			
Ref.Nr.: 06H105243F	Ref.Nr.: 1K0505553 A	Ref.Nr.: 1K0199868Q	Ref.Nr.: 1K0407183G			

Article Description



Article Nr.

Fitting Position



**Q5 (8R)**

11/2008 →

Belt Pulley, crankshaft	2.0 TDI quattro	CJCA; Number of Ribs: 5; Parameter: 6PK	<b>F8-6572</b>		
Belt Pulley, crankshaft	2.0 TDI quattro	CJC B; Number of Ribs: 5; Parameter: 6PK	<b>F8-6572</b>		
Control Arm-/Trailing Arm Bush	2.0 TDI quattro, 2.0 TFSI quattro, 3.0 TDI quattro, 3.2 FSI quattro		<b>F8-6582</b>	⊕ ⊕ ⊕ ↓	
Control Arm-/Trailing Arm Bush	2.0 TDI, 2.0 TDI quattro, 2.0 TFSI hybrid quattro, 2.0 TFSI quattro, 3.0 TDI quattro, 3.2 FSI quattro		<b>F8-6784</b>	⊕ ⊕ ⊕ ↓	H=45; d=12.2; D=43.8
Top Strut Mounting	2.0 TDI, 2.0 TDI quattro, 2.0 TFSI hybrid quattro, 2.0 TFSI quattro, 3.0 TDI quattro, 3.0 TFSI quattro, 3.2 FSI quattro, SQ5 quattro		<b>F8-7452</b>	⊕ ⊕	
Protective Cap/Bellow, shock absorber	2.0 TDI, 2.0 TDI quattro, 2.0 TFSI hybrid quattro, 2.0 TFSI quattro, 3.0 TDI quattro, 3.0 TFSI quattro, 3.2 FSI quattro, SQ5 quattro		<b>F8-7681</b>		H=100
Rubber Buffer, suspension	2.0 TDI	for OE: 1BV;	<b>F8-7704</b>		H=145
Rubber Buffer, suspension	2.0 TDI quattro, 2.0 TFSI quattro, 3.0 TDI quattro, 3.2 FSI quattro	for OE: 1BA, 1BV;	<b>F8-7704</b>		H=145
Rubber Buffer, suspension	2.0 TFSI hybrid quattro	for OE: 1BA;	<b>F8-7704</b>		H=145
Rubber Buffer, suspension	SQ5 quattro		<b>F8-7715</b>		H=81
Top Strut Mounting	2.0 TDI, 2.0 TDI quattro, 2.0 TFSI hybrid quattro, 2.0 TFSI quattro, 3.0 TDI quattro, 3.0 TFSI quattro, 3.2 FSI quattro, SQ5 quattro	not for PR: 1BL;	<b>F8-7742</b>	⊕ ⊕	
Rubber Buffer, suspension	2.0 TDI, 2.0 TDI quattro, 2.0 TFSI hybrid quattro, 2.0 TFSI quattro, 3.0 TDI quattro, 3.0 TFSI quattro, 3.2 FSI quattro	for OE: 1BA, 1BV;	<b>F8-7801</b>		H=97
Rubber Buffer, suspension	SQ5 quattro	for OE: 2MT;	<b>F8-7801</b>		H=97
Protective Cap/Bellow, shock absorber	2.0 TDI quattro, 2.0 TFSI quattro, 3.0 TDI quattro, 3.2 FSI quattro	for OE: 1BA, 1BV;	<b>F8-7802</b>		H=156
Protective Cap/Bellow, shock absorber	2.0 TDI	for OE: 1BA, 1BV, 2MF;	<b>F8-7813</b>		H=167
Protective Cap/Bellow, shock absorber	2.0 TDI quattro, 2.0 TFSI quattro, 3.0 TDI quattro, 3.0 TFSI quattro	for OE: 1BA, 1BV;	<b>F8-7813</b>		H=167
Protective Cap/Bellow, shock absorber	2.0 TDI quattro, 2.0 TFSI quattro, 3.0 TDI quattro, 3.2 FSI quattro	08/2009 →; for OE: 1BA, 1BV;	<b>F8-7813</b>		H=167
Protective Cap/Bellow, shock absorber	2.0 TFSI hybrid quattro		<b>F8-7813</b>		H=167
Protective Cap/Bellow, shock absorber	SQ5 quattro	for OE: 1BD	<b>F8-7813</b>		H=167
Protective Cap/Bellow, shock absorber	2.0 TDI, 2.0 TDI quattro, 2.0 TFSI hybrid quattro, 2.0 TFSI quattro, 3.0 TDI quattro, 3.0 TFSI quattro, 3.2 FSI quattro, SQ5 quattro	for OE: 1BL;	<b>F8-7814</b>		
Rubber Buffer, suspension	2.0 TDI, 2.0 TDI quattro, 2.0 TFSI hybrid quattro, 2.0 TFSI quattro, 3.0 TDI quattro, 3.0 TFSI quattro, 3.2 FSI quattro, SQ5 quattro	for OE: 2MF;	<b>F8-7844</b>	⊕ ⊕	Lowering ca. [mm]=25
Belt Pulley, crankshaft	2.0 TFSI hybrid quattro, 2.0 TFSI quattro	Number of Ribs: 5; Parameter: 6PK	<b>F8-7880</b>		D=143

<b>F8-6572</b>	<b>F8-6582</b>	<b>F8-6784</b>	<b>F8-7452</b>	<b>F8-7681</b>	<b>F8-7704</b>	<b>F8-7715</b>
Ref.Nr.: 038105243L	Ref.Nr.: 8K0407182A	Ref.Nr.: 4E0407181B	Ref.Nr.: 8K0513353D	Ref.Nr.: 8K0412137A	Ref.Nr.: 8K0512131H	Ref.Nr.: 8K0412131E
<b>F8-7742</b>	<b>F8-7801</b>	<b>F8-7802</b>	<b>F8-7813</b>	<b>F8-7814</b>	<b>F8-7844</b>	<b>F8-7880</b>
Ref.Nr.: 8K0412377A	Ref.Nr.: 8R0412131D	Ref.Nr.: 4B0512137B	Ref.Nr.: 4G0512137A	Ref.Nr.: 8K0512137A	Ref.Nr.: 4F0512131D	Ref.Nr.: 06H105243F
<b>F8-7941</b>						
Ref.Nr.: 8K0407183A						

**Article Description****Article Nr.****Fitting Position**

<b>Q5 (8R)</b>			<b>11/2008 →</b>		
Control Arm-/Trailing Arm Bush	2.0 TDI quattro, 2.0 TFSI quattro, 3.0 TDI quattro		<b>F8-7941</b>		
Control Arm-/Trailing Arm Bush	2.0 TDI quattro, 2.0 TFSI quattro, 3.0 TDI quattro, 3.2 FSI quattro	07/2009 →	<b>F8-7999</b>		H=80; d=13; D=75
Control Arm-/Trailing Arm Bush	2.0 TDI, 2.0 TDI quattro, 2.0 TFSI quattro, 3.0 TDI quattro, 3.0 TFSI quattro, SQ5 quattro		<b>F8-7999</b>		H=80; d=13; D=75
Control Arm-/Trailing Arm Bush	2.0 TDI, 2.0 TDI quattro, 2.0 TFSI hybrid quattro, 2.0 TFSI quattro, 3.0 TDI quattro, 3.2 FSI quattro		<b>F8-8073</b>		
<b>Q7 (4L)</b>			<b>03/2006 → 08/2015</b>		
Dust Cover Kit, shock absorber	3.0 TDI, 3.0 TFSI, 3.6 FSI, 4.2 FSI, 4.2 TDI, 6.0 TDI	for OE: 1BA, 1BW;	<b>AK-735182</b>		
Dust Cover Kit, shock absorber	3.0 TDI, 3.6 FSI, 4.2 FSI, 4.2 TDI		<b>AK-735183</b>		
Dust Cover Kit, shock absorber	3.0 TDI, 3.0 TFSI, 3.6 FSI, 4.2 FSI, 4.2 TDI, 6.0 TDI	for OE: 1BK, 2MB;	<b>AK-735190</b>		
Dust Cover Kit, shock absorber	3.0 TDI, 3.0 TFSI, 3.6 FSI, 4.2 FSI, 4.2 TDI, 6.0 TDI	for OE: 1BK, 2MB;	<b>AK-735191</b>		
Dust Cover Kit, shock absorber	3.0 TDI, 4.2 TDI	for OE: 1BK;	<b>AK-735191</b>		
Alternator Freewheel Clutch	3.0 TDI, 4.2 TDI, 6.0 TDI		<b>F5-1140</b>		
Control Arm-/Trailing Arm Bush	3.0 TDI, 3.6 FSI, 4.2 FSI, 4.2 TDI		<b>F8-5301</b>		d=14.2; L=74; D=46,5
Control Arm-/Trailing Arm Bush	3.0 TDI, 3.6 FSI, 4.2 FSI, 4.2 TDI		<b>F8-6705</b>		H=43; d=10; D=40
Control Arm-/Trailing Arm Bush	3.0 TDI, 3.6 FSI, 4.2 FSI, 4.2 TDI		<b>F8-6706</b>		D=60.05
Control Arm-/Trailing Arm Bush	3.0 TDI, 3.6 FSI, 4.2 FSI, 4.2 TDI, 6.0 TDI		<b>F8-6707</b>		
Rubber Buffer, suspension	3.0 TDI, 3.0 TFSI, 3.6 FSI, 4.2 FSI, 4.2 TDI, 6.0 TDI	for OE: 1BA, 1BW;	<b>F8-7803</b>		H=78
Protective Cap/Bellow, shock absorber	3.0 TDI, 3.0 TFSI, 3.6 FSI, 4.2 FSI, 4.2 TDI, 6.0 TDI	for OE: 1BA, 1BM, 1BV, 1BW;	<b>F8-7804</b>		H=214
Protective Cap/Bellow, shock absorber	3.0 TDI, 3.0 TFSI, 3.6 FSI, 4.2 FSI, 4.2 TDI, 6.0 TDI	for OE: 1BA, 1BM, 1BV, 1BW;	<b>F8-7804</b>		H=214
Rubber Buffer, suspension	3.0 TDI, 3.0 TFSI, 3.6 FSI, 4.2 FSI, 4.2 TDI, 6.0 TDI	for OE: 1BK, 2MB;	<b>F8-7805</b>		H=64
Protective Cap/Bellow, shock absorber	3.0 TDI, 3.0 TFSI, 3.6 FSI, 4.2 FSI, 4.2 TDI, 6.0 TDI	for OE: 1BK, 2MB;	<b>F8-7806</b>		H=180
Protective Cap/Bellow, shock absorber	3.0 TDI, 3.0 TFSI, 3.6 FSI, 4.2 FSI, 4.2 TDI, 6.0 TDI	for OE: 1BK, 2MB;	<b>F8-7806</b>		H=180
Rubber Buffer, suspension	3.0 TDI, 3.0 TFSI, 3.6 FSI, 4.2 FSI, 4.2 TDI, 6.0 TDI	for OE: 1BA, 1BM, 1BV, 1BW;	<b>F8-7807</b>		H=90
Rubber Buffer, suspension	3.0 TDI, 3.0 TFSI, 3.6 FSI, 4.2 FSI, 4.2 TDI, 6.0 TDI	for OE: 1BK, 2MB;	<b>F8-7808</b>		H=76
Rubber Buffer, suspension	3.0 TDI, 4.2 TDI	for OE: 1BK;	<b>F8-7808</b>		H=76
Control Arm-/Trailing Arm Bush	3.0 TDI, 3.0 TFSI, 4.2 TDI, 6.0 TDI		<b>F8-7875</b>		D=72
Control Arm-/Trailing Arm Bush	3.0 TDI, 3.6 FSI, 4.2 FSI	ch.4L-8-053 605→	<b>F8-7875</b>		D=72
Mounting, axle beam	3.0 TDI, 3.0 TFSI, 3.6 FSI, 4.2 FSI, 4.2 TDI, 6.0 TDI		<b>F8-8131</b>		H=62; d=23; D=93

<b>AK-735182</b>	<b>AK-735183</b>	<b>AK-735190</b>	<b>AK-735191</b>	<b>F5-1140</b>	<b>F8-5301</b>	<b>F8-6705</b>
Ref.Nr.: 7L0412137	Ref.Nr.: 7L0498137	Ref.Nr.: 7L0412303A	Ref.Nr.: 7L0498137	Ref.Nr.: 059903119L	Ref.Nr.: 95534324301	Ref.Nr.: 7L0407077
<b>F8-6706</b>	<b>F8-6707</b>	<b>F8-7803</b>	<b>F8-7804</b>	<b>F8-7805</b>	<b>F8-7806</b>	<b>F8-7807</b>
Ref.Nr.: 7L0407182C	Ref.Nr.: 7L0407183A	Ref.Nr.: 7L8412303	Ref.Nr.: 7L0412137	Ref.Nr.: 7L0412303A	Ref.Nr.: 7L0498137	Ref.Nr.: 7L0512131B
<b>F8-7808</b>	<b>F8-7875</b>	<b>F8-7941</b>	<b>F8-7999</b>	<b>F8-8073</b>	<b>F8-8131</b>	<b>LM-10100S</b>
Ref.Nr.: 7L0512131C	Ref.Nr.: 7L0407182D	Ref.Nr.: 8K0407183A	Ref.Nr.: 8K0407183D	Ref.Nr.: 8K0501530N	Ref.Nr.: 7L0499035A	Ref.Nr.: 32106765782

Article Description



Article Nr.

Fitting Position



<b>Q7 (4L)</b>			<b>03/2006 → 08/2015</b>	
Bellow, steering	3.0 TDI, 3.0 TFSI, 3.6 FSI, 4.2 FSI, 4.2 TDI, 6.0 TDI	with clamps	<b>LM-10100S</b>	d1=15.5; d2=66; L [mm]=195
<b>QUATTRO (85)</b>			<b>07/1980 → 07/1991</b>	
Dust Cover Kit, shock absorber	2.1 20V Turbo, 2.1 Turbo		<b>AK-735002</b>	
Engine Mounting	2.1 20V Turbo, 2.1 Turbo	ch.85-H-900041→; 01/1987 →;	<b>F8-1020</b>	H=97; D=114; T [mm]=145
Engine Mounting	2.2 20V, 2.2 Turbo	ch.85-H-900041→;	<b>F8-1020</b>	H=97; D=114; T [mm]=145
Engine Mounting	2.1 20V Turbo, 2.1 Turbo	ch.85-H-900401→; 01/1987 →;	<b>F8-1021</b>	H=97; D=114; T [mm]=143
Engine Mounting	2.2 20V, 2.2 Turbo	ch.85-H-900401→;	<b>F8-1021</b>	H=97; D=114; T [mm]=143
Control Arm-/Trailing Arm Bush	2.1 Turbo		<b>F8-1026</b>	H=44; d=10; D1=38; D2=48
Top Strut Mounting	2.1 Turbo, 2.2 Turbo		<b>F8-1027</b>	H=37; d1=14; d2=20; D=76
Anti-Friction Bearing	2.1 Turbo, 2.2 20V, 2.2 Turbo		<b>F8-3036</b>	
Mounting, radiator	2.1 20V Turbo		<b>F8-4009</b>	H1=15; H2=37; D=39; Outer Thread [mm]=M8 x 1,50
Mounting, radiator	2.1 Turbo, 2.2 20V, 2.2 Turbo		<b>F8-4011</b>	H1=16; H2=38; D=30; Outer Thread [mm]=M8 x 1,25
Clamp, silencer	2.1 20V Turbo, 2.1 Turbo, 2.2 Turbo		<b>F8-4027</b>	H=17; W=53, 61
Mounting, automatic transmission	2.1 Turbo, 2.2 20V, 2.2 Turbo		<b>F8-4028</b>	H=42; D=11; D1=50; D2=80; T [mm]=94
Control Arm-/Trailing Arm Bush	2.1 20V Turbo, 2.1 Turbo, 2.2 20V, 2.2 Turbo		<b>F8-4043</b>	H=44; d=10; D1=37; D2=54
Bellow, steering	2.1 20V Turbo, 2.1 Turbo, 2.2 20V, 2.2 Turbo		<b>F8-4073</b>	H=147; D=48
Bellow, steering	2.1 20V Turbo, 2.1 quattro, 2.1 Turbo, 2.2 20V, 2.2 quattro, 2.2 Turbo	with clamps	<b>LM-10026S</b>	d1=27; d2=45; L [mm]=150
Bellow, steering	2.2 quattro	HY; with clamps	<b>LM-10026S</b>	d1=27; d2=45; L [mm]=150
<b>SUPER 90</b>			<b>09/1966 → 08/1971</b>	
Dust Cover Kit, shock absorber	All Models		<b>AK-735002</b>	
<b>TT (8N3)</b>			<b>10/1998 → 06/2006</b>	
Dust Cover Kit, shock absorber	All Models	<b>ST</b>	<b>AK-735410</b>	H=210
Dust Cover Kit, shock absorber	1.8 T	<b>ST</b>	<b>AK-735411</b>	
Alternator Freewheel Clutch	All Models		<b>F5-1004</b>	
Anti-Friction Bearing	All Models		<b>F8-3039</b>	H=14; d1=14; D=45
Top Strut Mounting	All Models		<b>F8-4067</b>	H=53; d=26; D=82
Top Strut Mounting	1.8 T		<b>F8-5380</b>	
Rubber Buffer, suspension	1.8 T		<b>F8-5381</b>	H=37; D=76
Spring Cap	All Models		<b>F8-5580</b>	D=92
Belt Pulley, crankshaft	1.8 T, 1.8 T quattro		<b>F8-5650</b>	

<b>AK-735002</b>	<b>AK-735410</b>	<b>AK-735411</b>	<b>F5-1004</b>	<b>F8-1020</b>	<b>F8-1021</b>	<b>F8-1026</b>
Ref.Nr.:	Ref.Nr.: 1J0412303	Ref.Nr.: 1J0512131C	Ref.Nr.: 038903119T	Ref.Nr.: 443199379	Ref.Nr.: 443199382	Ref.Nr.: 811407181A
<b>F8-1027</b>	<b>F8-3036</b>	<b>F8-3039</b>	<b>F8-4009</b>	<b>F8-4011</b>	<b>F8-4027</b>	<b>F8-4028</b>
Ref.Nr.: 811412323D	Ref.Nr.: 377412335A	Ref.Nr.: 357412249A	Ref.Nr.: 431121273	Ref.Nr.: 803121273	Ref.Nr.: 171253147A	Ref.Nr.: 431399151D
<b>F8-4043</b>	<b>F8-4067</b>	<b>F8-4073</b>	<b>F8-5380</b>	<b>F8-5381</b>	<b>F8-5580</b>	<b>F8-5650</b>
Ref.Nr.: 8A0407181	Ref.Nr.: 1J0412331B	Ref.Nr.: 811419831B	Ref.Nr.: 1J0513353G	Ref.Nr.: 1J0512149B	Ref.Nr.: 1J0412341	Ref.Nr.: 06A105243E



**Article Description****Article Nr.****Fitting Position**

<b>TT (8N3)</b>			<b>10/1998 → 06/2006</b>		
Protective Cap/Bellow, shock absorber	All Models		<b>F8-5683</b>		H=210
Rubber Buffer, suspension	All Models	for OE: G78, G98; <b>SP</b>	<b>F8-5996</b>		H=63
Rubber Buffer, suspension	1.8 T	<b>SP</b>	<b>F8-6007</b>		H=116
Rubber Buffer, suspension	1.8 T, 1.8 T quattro	for OE: G17, G97	<b>F8-6041</b>		H=53
Rubber Buffer, suspension	1.8 T, 1.8 T quattro	for OE: G17, G97; <b>SP</b>	<b>F8-6041</b>		H=53
Protective Cap/Bellow, shock absorber	1.8 T		<b>F8-6045</b>		
Mounting, axle beam	1.8 T		<b>F8-6076</b>		d=12; L=90; D=69
Mounting, axle beam	1.8 T	APP	<b>F8-6076</b>		d=12; L=90; D=69
Repair Set, axle beam	1.8 T		<b>F8-6077</b>		H=90; D=69
Repair Set, axle beam	1.8 T	APP	<b>F8-6077</b>		H=90; D=69
Top Strut Mounting	All Models		<b>F8-6280</b>		H=53; d=26; D=82
Control Arm-/Trailing Arm Bush	1.8 T, 1.8 T quattro	ch.8N-Y-060001-→; for OE: 8N0407151D, 8N0407152D	<b>F8-6464</b>		H=41; d=13.5; W=60
Control Arm-/Trailing Arm Bush	1.8 T, 1.8 T quattro, 3.2 VR6 quattro	for OE: 8N0407151D, 8N0407152D	<b>F8-6464</b>		H=41; d=13.5; W=60
Bracket, stabilizer mounting	1.8 T	AJQ, APP, ARY, AUQ	<b>F8-6579</b>		
Bracket, stabilizer mounting	1.8 T quattro	AJQ, ARY	<b>F8-6579</b>		
Bracket, stabilizer mounting	1.8 T quattro	APX, BAM	<b>F8-6579</b>		
Bracket, stabilizer mounting	1.8 T, 1.8 T quattro, 3.2 VR6 quattro		<b>F8-6579</b>		
Control Arm-/Trailing Arm Bush	1.8 T	ch.8L-Y-060001-→;  AJQ, APP, ARY, AUQ, AWP	<b>F8-6775</b>		H=54; d=12; D=45
Control Arm-/Trailing Arm Bush	1.8 T, 1.8 T quattro, 3.2 VR6 quattro	ch.8L-Y-060001-→	<b>F8-6775</b>		H=54; d=12; D=45
Engine Mounting	1.8 T		<b>F8-7033</b>		
Engine Mounting	1.8 T	AJQ, APP, ARY, AUQ;	<b>F8-7033</b>		
Engine Mounting	1.8 T quattro	AJQ, ARY;	<b>F8-7033</b>		
Engine Mounting	1.8 T quattro	APX, BAM;	<b>F8-7033</b>		
Mounting, axle bracket	1.8 T quattro		<b>F8-7046</b>		H=55; d=16; D=52
Mounting, axle bracket	1.8 T quattro	AJQ, ARY;  6-speed,  6-speed	<b>F8-7046</b>		H=55; d=16; D=52
Mounting, axle bracket	1.8 T quattro	APX, BAM;  6-speed,  6-speed	<b>F8-7046</b>		H=55; d=16; D=52
Mounting, axle bracket	3.2 VR6 quattro	6-speed,  6-speed	<b>F8-7046</b>		H=55; d=16; D=52
Top Strut Mounting	All Models	for OE: 1J0412319C	<b>F8-7133</b>		
Stabiliser Mounting	1.8 T	ch.→8N-2-070000;  APP	<b>F8-7901</b>		
Stabiliser Mounting	1.8 T	ch.→8N-2-070000;  ATC	<b>F8-7901</b>		
Stabiliser Mounting	1.8 T quattro	ch.→8N-2-070000;  APX	<b>F8-7901</b>		

<b>F8-5683</b>	<b>F8-5996</b>	<b>F8-6007</b>	<b>F8-6041</b>	<b>F8-6045</b>	<b>F8-6076</b>	<b>F8-6077</b>
Ref.Nr.: 357413175A	Ref.Nr.: 1H0412303B	Ref.Nr.: 1J0512131C	Ref.Nr.: 1J0412303	Ref.Nr.: 1J0513425A	Ref.Nr.: 1J0501541D	Ref.Nr.: 1J0501541DS
<b>F8-6280</b>	<b>F8-6464</b>	<b>F8-6579</b>	<b>F8-6775</b>	<b>F8-7033</b>	<b>F8-7046</b>	<b>F8-7133</b>
Ref.Nr.: 6R0412249	Ref.Nr.: 8N0407181B	Ref.Nr.: 1J0 411 336 C	Ref.Nr.: 8N0407182A	Ref.Nr.: 8N0199555C	Ref.Nr.: 1J0505145B	Ref.Nr.: 1J0412319C
<b>F8-7901</b>						
Ref.Nr.: 1J0411314P						

Article Description



Article Nr.

Fitting Position



<b>TT (8N3)</b>			<b>10/1998 → 06/2006</b>		
Stabiliser Mounting	1.8 T, 1.8 T quattro	ch.→8N-2-070000;  AJQ	<b>F8-7901</b>		
Stabiliser Mounting	All Models		<b>F8-7927</b>		d=18
Control Arm-/Trailing Arm Bush	1.8 T, 1.8 T quattro	ch.→8N-Y-060000	<b>F8-7978</b>		
Control Arm-/Trailing Arm Bush	1.8 T, 1.8 T quattro	ch.→8N-Y-060000	<b>G9-648</b>		H=54; d=12; D1=33; D2=36
Control Arm-/Trailing Arm Bush	1.8 T, 1.8 T quattro		<b>G9-649</b>		H1=25; H2=41; d=13; D=60
Bellow, steering	1.8 T	AJQ, APP, ARY, AUQ, AWP; with clamps;	<b>LM-10020S</b>		d1=16; d2=48; L [mm]=179
Bellow, steering	1.8 T, 1.8 T quattro, 3.2 VR6 quattro	with clamps;	<b>LM-10020S</b>		d1=16; d2=48; L [mm]=179
<b>TT Roadster (8N9)</b>			<b>10/1999 → 06/2006</b>		
Dust Cover Kit, shock absorber	1.8 T, 1.8 T quattro, 3.2 VR6 quattro	<b>ST</b>	<b>AK-735410</b>		H=210
Dust Cover Kit, shock absorber	1.8 T	<b>ST</b>	<b>AK-735411</b>		
Alternator Freewheel Clutch	1.8 T, 1.8 T quattro, 3.2 VR6 quattro		<b>F5-1004</b>		
Anti-Friction Bearing	1.8 T, 1.8 T quattro, 3.2 VR6 quattro		<b>F8-3039</b>		H=14; d1=14; D=45
Top Strut Mounting	1.8 T, 1.8 T quattro, 3.2 VR6 quattro		<b>F8-4067</b>		H=53; d=26; D=82
Top Strut Mounting	1.8 T		<b>F8-5380</b>		
Rubber Buffer, suspension	1.8 T		<b>F8-5381</b>		H=37; D=76
Spring Cap	1.8 T, 1.8 T quattro, 3.2 VR6 quattro		<b>F8-5580</b>		D=92
Belt Pulley, crankshaft	1.8 T, 1.8 T quattro		<b>F8-5650</b>		
Protective Cap/Bellow, shock absorber	1.8 T, 1.8 T quattro, 3.2 VR6 quattro		<b>F8-5683</b>		H=210
Rubber Buffer, suspension	1.8 T, 1.8 T quattro, 3.2 VR6 quattro	for OE: G78, G98; <b>SP</b>	<b>F8-5996</b>		H=63
Rubber Buffer, suspension	1.8 T	<b>SP</b>	<b>F8-6007</b>		H=116
Rubber Buffer, suspension	1.8 T, 1.8 T quattro	for OE: G17, G97	<b>F8-6041</b>		H=53
Rubber Buffer, suspension	1.8 T, 1.8 T quattro	for OE: G17, G97; <b>SP</b>	<b>F8-6041</b>		H=53
Protective Cap/Bellow, shock absorber	1.8 T		<b>F8-6045</b>		
Mounting, axle beam	1.8 T		<b>F8-6076</b>		d=12; L=90; D=69
Mounting, axle beam	1.8 T	AJQ	<b>F8-6076</b>		d=12; L=90; D=69
Repair Set, axle beam	1.8 T		<b>F8-6077</b>		H=90; D=69
Repair Set, axle beam	1.8 T	AUQ	<b>F8-6077</b>		H=90; D=69
Top Strut Mounting	1.8 T, 1.8 T quattro, 3.2 VR6 quattro		<b>F8-6280</b>		H=53; d=26; D=82
Control Arm-/Trailing Arm Bush	1.8 T, 1.8 T quattro	ch.8N-Y-060001→; for OE: 8N0407151D, 8N0407152D	<b>F8-6464</b>		H=41; d=13,5; W=60
Control Arm-/Trailing Arm Bush	1.8 T, 1.8 T quattro, 3.2 VR6 quattro	for OE: 8N0407151D, 8N0407152D	<b>F8-6464</b>		H=41; d=13,5; W=60

<b>AK-735410</b>	<b>AK-735411</b>	<b>F5-1004</b>	<b>F8-3039</b>	<b>F8-4067</b>	<b>F8-5380</b>	<b>F8-5381</b>
Ref.Nr.: 1J0412303	Ref.Nr.: 1J0512131C	Ref.Nr.: 038903119T	Ref.Nr.: 357412249A	Ref.Nr.: 1J0412331B	Ref.Nr.: 1J0513353G	Ref.Nr.: 1J0512149B
<b>F8-5580</b>	<b>F8-5650</b>	<b>F8-5683</b>	<b>F8-5996</b>	<b>F8-6007</b>	<b>F8-6041</b>	<b>F8-6045</b>
Ref.Nr.: 1J0412341	Ref.Nr.: 06A105243E	Ref.Nr.: 357413175A	Ref.Nr.: 1H0412303B	Ref.Nr.: 1J0512131C	Ref.Nr.: 1J0412303	Ref.Nr.: 1J0513425A
<b>F8-6076</b>	<b>F8-6077</b>	<b>F8-6280</b>	<b>F8-6464</b>	<b>F8-6579</b>	<b>F8-7901</b>	<b>F8-7927</b>
Ref.Nr.: 1J0501541D	Ref.Nr.: 1J0501541DS	Ref.Nr.: 6R0412249	Ref.Nr.: 8N0407181B	Ref.Nr.: 1J0 411 336 C	Ref.Nr.: 1J0411314P	Ref.Nr.: 1J0411314AC

**Article Description****Article Nr.****Fitting Position**

<b>TT Roadster (8N9)</b>				<b>10/1999 → 06/2006</b>	
Bracket, stabilizer mounting	1.8 T	AJQ, APP, AUQ	<b>F8-6579</b>		
Bracket, stabilizer mounting	1.8 T quattro	AJQ, ARY	<b>F8-6579</b>		
Bracket, stabilizer mounting	1.8 T quattro	APX, BAM	<b>F8-6579</b>		
Bracket, stabilizer mounting	1.8 T, 1.8 T quattro, 3.2 VR6 quattro		<b>F8-6579</b>		
Control Arm-/Trailing Arm Bush	1.8 T	ch.8L-Y-060001 →;  AJQ, APP, AUQ, AWP	<b>F8-6775</b>		H=54; d=12; D=45
Control Arm-/Trailing Arm Bush	1.8 T, 1.8 T quattro, 3.2 VR6 quattro	ch.8L-Y-060001 →	<b>F8-6775</b>		H=54; d=12; D=45
Engine Mounting	1.8 T		<b>F8-7033</b>		
Engine Mounting	1.8 T	AJQ, APP, AUQ;	<b>F8-7033</b>		
Engine Mounting	1.8 T quattro	AJQ, ARY;	<b>F8-7033</b>		
Engine Mounting	1.8 T quattro	APX, BAM;	<b>F8-7033</b>		
Mounting, axle bracket	1.8 T quattro	AJQ, ARY;  6-speed,  6-speed	<b>F8-7046</b>		H=55; d=16; D=52
Mounting, axle bracket	1.8 T quattro	APX, BAM;  6-speed,  6-speed	<b>F8-7046</b>		H=55; d=16; D=52
Mounting, axle bracket	3.2 VR6 quattro	6-speed,  6-speed	<b>F8-7046</b>		H=55; d=16; D=52
Top Strut Mounting	1.8 T, 1.8 T quattro, 3.2 VR6 quattro	for OE: 1J0412319C	<b>F8-7133</b>		
Stabiliser Mounting	1.8 T	ch.→8N-2-070000;  APP	<b>F8-7901</b>		
Stabiliser Mounting	1.8 T quattro	ch.→8N-2-070000;  APX	<b>F8-7901</b>		
Stabiliser Mounting	1.8 T, 1.8 T quattro	ch.→8N-2-070000;  AJQ	<b>F8-7901</b>		
Stabiliser Mounting	1.8 T, 1.8 T quattro, 3.2 VR6 quattro		<b>F8-7927</b>		d=18
Control Arm-/Trailing Arm Bush	1.8 T, 1.8 T quattro	ch.→8N-Y-060000	<b>F8-7978</b>		
Control Arm-/Trailing Arm Bush	1.8 T, 1.8 T quattro	ch.→8N-Y-060000	<b>G9-648</b>		H=54; d=12; D1=33; D2=36
Control Arm-/Trailing Arm Bush	1.8 T, 1.8 T quattro		<b>G9-649</b>		H1=25; H2=41; d=13; D=60
Bellow, steering	1.8 T	AJQ, APP, AUQ, AWP; with clamps;	<b>LM-10020S</b>		d1=16; d2=48; L [mm]=179
Bellow, steering	1.8 T quattro	AJQ, ARY; with clamps;	<b>LM-10020S</b>		d1=16; d2=48; L [mm]=179
Bellow, steering	1.8 T, 1.8 T quattro, 3.2 VR6 quattro	with clamps;	<b>LM-10020S</b>		d1=16; d2=48; L [mm]=179

<b>TT (8J3)</b>				<b>08/2006 → 06/2014</b>	
Alternator Freewheel Clutch	2.0 quattro, 2.0 TDI quattro, 2.0 TFSI, 2.0 TFSI quattro, 3.2 V6 quattro		<b>F5-1004</b>		
Alternator Freewheel Clutch	1.8 TFSI, 2.0 TFSI, 2.0 TFSI quattro		<b>F5-1044</b>		
Alternator Freewheel Clutch	3.2 V6 quattro		<b>F5-1085</b>		
Control Arm-/Trailing Arm Bush	All Models		<b>F8-5633</b>		
Protective Cap/Bellow, shock absorber	1.8 TFSI, 2.0 TFSI, 2.5 TFSI quattro		<b>F8-6044</b>		H=160

<b>F5-1004</b>	<b>F5-1044</b>	<b>F5-1085</b>	<b>F8-5633</b>	<b>F8-6044</b>	<b>F8-6579</b>	<b>F8-6775</b>
Ref.Nr.: 038903119T	Ref.Nr.: 06B903119B	Ref.Nr.: 045903119A	Ref.Nr.: 1K0407182A	Ref.Nr.: 3C0513425	Ref.Nr.: 1J0 411 336 C	Ref.Nr.: 8N0407182A
<b>F8-7033</b>	<b>F8-7046</b>	<b>F8-7133</b>	<b>F8-7901</b>	<b>F8-7927</b>	<b>F8-7978</b>	<b>G9-648</b>
Ref.Nr.: 8N0199555C	Ref.Nr.: 1J0505145B	Ref.Nr.: 1J0412319C	Ref.Nr.: 1J0411314P	Ref.Nr.: 1J0411314AC	Ref.Nr.: 357407182F	Ref.Nr.: 357407182
<b>G9-649</b>	<b>LM-10020S</b>					
Ref.Nr.: 1J0407181	Ref.Nr.: 1J0422831B					

**Article Description**

**Article Nr.**
**Fitting Position**

<b>TT (8J3)</b>		<b>08/2006 → 06/2014</b>	
Protective Cap/Bellow, shock absorber	2.0 quattro, 2.0 TDI quattro, 2.0 TFSI quattro, 3.2 V6 quattro	for OE: 1BL, 1BQ;	<b>F8-6044</b>
Protective Cap/Bellow, shock absorber	2.0 quattro, 2.0 TDI quattro, 2.0 TFSI quattro, 3.2 V6 quattro	for OE: 1BV; <b>SP</b>	<b>F8-6044</b>
Mounting, axle beam	2.0 TFSI	BWA	<b>F8-6076</b>
Repair Set, axle beam	2.0 TFSI	BWA	<b>F8-6077</b>
Top Strut Mounting	1.8 TFSI, 2.0 quattro, 2.0 TDI quattro, 2.0 TFSI, 2.0 TFSI quattro, 2.5 TFSI quattro, 3.2 V6 quattro		<b>F8-6284</b>
Control Arm-/Trailing Arm Bush	1.8 TFSI, 2.0 quattro, 2.0 TDI quattro, 2.0 TFSI, 2.0 TFSI quattro, 2.5 TFSI quattro, 3.2 V6 quattro		<b>F8-6463</b>
Anti-Friction Bearing	All Models		<b>F8-6569</b>
Top Strut Mounting	1.8 TFSI, 2.0 quattro, 2.0 TDI quattro, 2.0 TFSI, 2.0 TFSI quattro, 2.5 TFSI quattro, 3.2 V6 quattro		<b>F8-6570</b>
Top Strut Mounting	2.5 TFSI quattro	for OE: 1BQ;	<b>F8-6570</b>
Belt Pulley, crankshaft	2.0 TDI quattro	CFGB; Number of Ribs: 5; Parameter: 6PK	<b>F8-6572</b>
Engine Mounting	2.0 TFSI	BPY, BWA	<b>F8-6989</b>
Engine Mounting	3.2 V6 quattro		<b>F8-7008</b>
Protective Cap/Bellow, shock absorber	All Models		<b>F8-7132</b>
Top Strut Mounting	All Models		<b>F8-7603</b>
Protective Cap/Bellow, shock absorber	2.0 quattro, 2.0 TDI quattro, 2.0 TFSI quattro, 3.2 V6 quattro	for OE: 1BA; <b>ST</b>	<b>F8-7682</b>
Engine Mounting	1.8 TFSI, 2.0 quattro, 2.0 TDI quattro, 2.0 TFSI, 2.0 TFSI quattro	Aluminium	<b>F8-7851</b>
Belt Pulley, crankshaft	1.8 TFSI, 2.0 quattro, 2.0 TFSI, 2.0 TFSI quattro	Number of Ribs: 5; Parameter: 6PK	<b>F8-7880</b>
Rubber Buffer, suspension	1.8 TFSI, 2.0 TFSI	for OE: 1BA, 1BV; <b>SP</b> , <b>ST</b>	<b>F8-7894</b>
Rubber Buffer, suspension	2.0 quattro, 2.0 TDI quattro, 2.0 TFSI quattro, 3.2 V6 quattro	for OE: 1BV; <b>SP</b>	<b>F8-7894</b>
Rubber Buffer, suspension	2.5 TFSI quattro	for OE: 1BD	<b>F8-7894</b>
Rubber Buffer, suspension	2.0 quattro, 2.0 TDI quattro, 2.0 TFSI quattro, 3.2 V6 quattro	for OE: 1BA; <b>ST</b>	<b>F8-7895</b>
Engine Mounting	1.8 TFSI, 2.0 quattro, 2.0 TFSI, 2.0 TFSI quattro, 2.5 TFSI quattro, 3.2 V6 quattro		<b>F8-7982</b>
Engine Mounting	2.0 TFSI	BPY, BWA, CCTA, CCZA	<b>F8-7982</b>
Engine Mounting	2.0 TFSI quattro	CCZA	<b>F8-7982</b>
<b>TT Roadster (8J9)</b>		<b>03/2007 → 06/2014</b>	
Alternator Freewheel Clutch	2.0 quattro, 2.0 TDI quattro, 2.0 TFSI, 2.0 TFSI quattro, 3.2 V6 quattro		<b>F5-1004</b>
Alternator Freewheel Clutch	1.8 TFSI, 2.0 TFSI, 2.0 TFSI quattro		<b>F5-1044</b>
Alternator Freewheel Clutch	3.2 V6 quattro		<b>F5-1085</b>



**Article Description****Article Nr.****Fitting Position**

<b>TT Roadster (8J9)</b>				<b>03/2007 → 06/2014</b>	
Control Arm-/Trailing Arm Bush	All Models		<b>F8-5633</b>		
Protective Cap/Bellow, shock absorber	1.8 TFSI, 2.0 TFSI, 2.5 TFSI quattro		<b>F8-6044</b>		H=160
Protective Cap/Bellow, shock absorber	2.0 quattro, 2.0 TDI quattro, 2.0 TFSI quattro, 3.2 V6 quattro	for OE: 1BL, 1BQ;	<b>F8-6044</b>		H=160
Protective Cap/Bellow, shock absorber	2.0 quattro, 2.0 TDI quattro, 2.0 TFSI quattro, 3.2 V6 quattro	for OE: 1BV;	<b>F8-6044</b>		H=160
Mounting, axle beam	2.0 TFSI	BWA	<b>F8-6076</b>		d=12; L=90; D=69
Repair Set, axle beam	2.0 TFSI	BWA	<b>F8-6077</b>		H=90; D=69
Top Strut Mounting	All Models		<b>F8-6284</b>		
Control Arm-/Trailing Arm Bush	1.8 TFSI, 2.0 quattro, 2.0 TDI quattro, 2.0 TFSI, 2.0 TFSI quattro, 2.5 TFSI quattro, 3.2 V6 quattro		<b>F8-6463</b>		H=64; d=12; D=60
Anti-Friction Bearing	All Models		<b>F8-6569</b>		
Top Strut Mounting	All Models		<b>F8-6570</b>		
Belt Pulley, crankshaft	2.0 TDI quattro	CFGB; Number of Ribs: 5; Parameter: 6PK	<b>F8-6572</b>		
Engine Mounting	3.2 V6 quattro		<b>F8-7008</b>		
Protective Cap/Bellow, shock absorber	All Models		<b>F8-7132</b>		H=190
Top Strut Mounting	All Models		<b>F8-7603</b>		
Protective Cap/Bellow, shock absorber	2.0 quattro, 2.0 TDI quattro, 2.0 TFSI quattro, 3.2 V6 quattro	for OE: 1BA;	<b>F8-7682</b>		H=160
Engine Mounting	1.8 TFSI, 2.0 quattro, 2.0 TDI quattro, 2.0 TFSI, 2.0 TFSI quattro	Aluminium	<b>F8-7851</b>		
Belt Pulley, crankshaft	1.8 TFSI, 2.0 TFSI, 2.0 TFSI quattro	Number of Ribs: 5; Parameter: 6PK	<b>F8-7880</b>		D=143
Rubber Buffer, suspension	1.8 TFSI, 2.0 TFSI	for OE: 1BA, 1BV; ,	<b>F8-7894</b>		
Rubber Buffer, suspension	2.0 quattro, 2.0 TDI quattro, 2.0 TFSI quattro, 3.2 V6 quattro	for OE: 1BV;	<b>F8-7894</b>		
Rubber Buffer, suspension	2.5 TFSI quattro	for OE: 1BD	<b>F8-7894</b>		
Rubber Buffer, suspension	2.0 quattro, 2.0 TDI quattro, 2.0 TFSI quattro, 3.2 V6 quattro	for OE: 1BA;	<b>F8-7895</b>		
Engine Mounting	1.8 TFSI, 2.0 quattro, 2.0 TFSI, 2.0 TFSI quattro, 2.5 TFSI quattro, 3.2 V6 quattro		<b>F8-7982</b>		
Engine Mounting	2.0 TFSI	BPY, BWA, CCTA, CCZA	<b>F8-7982</b>		
<b>V8 (44_, 4C_)</b>				<b>10/1988 → 02/1994</b>	
Control Arm-/Trailing Arm Bush	3.6 quattro		<b>F8-1017</b>		H=23; d=16; D=58
Control Arm-/Trailing Arm Bush	4.2 quattro	ch.→4C-M-020000	<b>F8-1017</b>		H=23; d=16; D=58
Control Arm-/Trailing Arm Bush	All Models		<b>F8-1018</b>		H1=31; H2=58; d=12; D1=21; D2=46











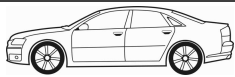

<b>F8-1017</b>	<b>F8-1018</b>	<b>F8-1022</b>	<b>F8-5633</b>	<b>F8-6044</b>	<b>F8-6076</b>	<b>F8-6077</b>
Ref.Nr.: 431407181F	Ref.Nr.: 431407183A	Ref.Nr.: 431399415B	Ref.Nr.: 1K0407182A	Ref.Nr.: 3C0513425	Ref.Nr.: 1J0501541D	Ref.Nr.: 1J0501541DS
<b>F8-6284</b>	<b>F8-6463</b>	<b>F8-6569</b>	<b>F8-6570</b>	<b>F8-6572</b>	<b>F8-7008</b>	<b>F8-7132</b>
Ref.Nr.: 6N0412249C	Ref.Nr.: 1K0505541B	Ref.Nr.: 6N0412249C	Ref.Nr.: 1K0412331C	Ref.Nr.: 038105243L	Ref.Nr.: 1K0199262Q	Ref.Nr.: 6N0413175A
<b>F8-7603</b>	<b>F8-7682</b>	<b>F8-7851</b>	<b>F8-7880</b>	<b>F8-7894</b>	<b>F8-7895</b>	<b>F8-7982</b>
Ref.Nr.: 3C0513353	Ref.Nr.: 8E0512137E	Ref.Nr.: 3C0199855A	Ref.Nr.: 06H105243F	Ref.Nr.: 8J0511353F	Ref.Nr.: 8J0511353G	Ref.Nr.: 1K0199868Q

<b>Article Description</b>			<b>Article Nr.</b>	<b>Fitting Position</b>	
----------------------------	--	--	--------------------	-------------------------	--

<b>V8 (44_, 4C_) 10/1988 → 02/1994</b>				
Mounting, axle bracket	All Models	<b>F8-1022</b>	H=57; d=12; D1=46; D2=62	
Anti-Friction Bearing	All Models	<b>F8-3007</b>	H=15; d=81; D=102	
Mounting, radiator	3.6 quattro	<b>F8-4011</b>	H1=16; H2=38; D=30; Outer Thread [mm]=M8 x 1,25	
Protective Cap/Bellow, shock absorber	All Models	<b>F8-4066</b>	H=105; D1=69; D2=105	
Bellow, steering	All Models	<b>F8-4070</b>	L=530; D1=40; D2=48	
Control Arm-/Trailing Arm Bush	3.6 quattro, 4.2 quattro	<b>F8-5306</b>	d=14; D=48; W=25	
Mounting, axle beam	All Models	<b>F8-5541</b>	d=12; D=58; W=35.8, 58	
Control Arm-/Trailing Arm Bush	All Models	<b>F8-5777</b>	H=23; d=14; D=44	
Control Arm-/Trailing Arm Bush	All Models	<b>F8-5778</b>	H=25; d=14; D=48	
<b>A3 Limousine (8VS) 05/2013 →</b>				
Alternator Freewheel Clutch	1.6 TDI	<b>F5-1085</b>		
Rubber Buffer, suspension	1.2 TFSI, 1.4 TFSI, 1.6 TDI, 1.8 TFSI, 1.8 TFSI quattro, 2.0 TDI, 2.0 TDI quattro, S3 quattro	for OE: 2UC, G01, G02, G03, G04, G21, G22, G23, G24; <b>SP</b>	<b>F8-7131</b>	H=70
Rubber Buffer, suspension	1.2 TFSI, 1.4 TFSI, 1.6 TDI, 1.8 TFSI, 1.8 TFSI quattro, 2.0 TDI, 2.0 TDI quattro	for OE: 2UA; <b>ST</b>	<b>F8-7174</b>	H=80
<b>A5 QUATTRO [USA] Coupe 01/2008 → 12/2008</b>				
Control Arm-/Trailing Arm Bush	3.2 quattro	<b>F8-7999</b>	H=80; d=13; D=75	
<b>Q7 [USA] Sport Utility 01/2007 → 12/2010</b>				
Dust Cover Kit, shock absorber	All Models	for OE: 1BA, 1BW; ; ; <b>ST</b>	<b>AK-735182</b>	
Dust Cover Kit, shock absorber	All Models	for OE: 1BK, 2MB; ;	<b>AK-735190</b>	
Dust Cover Kit, shock absorber	All Models	for OE: 1BK, 2MB; ;	<b>AK-735191</b>	
Rubber Buffer, suspension	All Models	for OE: 1BA, 1BW; ; <b>ST</b>	<b>F8-7803</b>	H=78
Protective Cap/Bellow, shock absorber	3.6 24V AWD, 4.2 32V AWD	for OE: 1BA, 1BM, 1BV, 1BW; ; ; <b>SP</b> , <b>ST</b>	<b>F8-7804</b>	H=214
Protective Cap/Bellow, shock absorber	3.6 24V AWD, 4.2 32V AWD	for OE: 1BA, 1BM, 1BV, 1BW; ; ; <b>SP</b> , <b>ST</b>	<b>F8-7804</b>	H=214
Rubber Buffer, suspension	All Models	for OE: 1BK, 2MB; ;	<b>F8-7805</b>	H=64
Protective Cap/Bellow, shock absorber	3.6 24V AWD, 4.2 32V AWD	for OE: 1BK, 2MB; ;	<b>F8-7806</b>	H=180
Protective Cap/Bellow, shock absorber	3.6 24V AWD, 4.2 32V AWD	for OE: 1BK, 2MB; ;	<b>F8-7806</b>	H=180
Rubber Buffer, suspension	All Models	for OE: 1BA, 1BW; ; <b>ST</b>	<b>F8-7807</b>	H=90
Rubber Buffer, suspension	All Models	for OE: 1BK, 2MB; ;	<b>F8-7808</b>	H=76

<b>AK-735182</b>	<b>AK-735190</b>	<b>AK-735191</b>	<b>F5-1085</b>	<b>F8-1022</b>	<b>F8-3007</b>	<b>F8-4011</b>
Ref.Nr.: 7L0412137	Ref.Nr.: 7L0412303A	Ref.Nr.: 7L0498137	Ref.Nr.: 045903119A	Ref.Nr.: 431399415B	Ref.Nr.: 431412249D	Ref.Nr.: 803121273
<b>F8-4066</b>	<b>F8-4070</b>	<b>F8-5306</b>	<b>F8-5541</b>	<b>F8-5777</b>	<b>F8-5778</b>	<b>F8-7131</b>
Ref.Nr.: 431412175D	Ref.Nr.: 431419831	Ref.Nr.: 4A0511247B	Ref.Nr.: 4D0511523C	Ref.Nr.: 443511247D	Ref.Nr.: 4A0511249	Ref.Nr.: 1K0412303B
<b>F8-7174</b>	<b>F8-7803</b>	<b>F8-7804</b>	<b>F8-7805</b>	<b>F8-7806</b>	<b>F8-7807</b>	<b>F8-7808</b>
Ref.Nr.: 1K0412303M	Ref.Nr.: 7L8412303	Ref.Nr.: 7L0412137	Ref.Nr.: 7L0412303A	Ref.Nr.: 7L0498137	Ref.Nr.: 7L0512131B	Ref.Nr.: 7L0512131C



Article Description				Article Nr.	Fitting Position	
<b>MAESTRO (XC)</b>						<b>03/1983 → 08/1990</b>
Dust Cover Kit, shock absorber	1.3, 1.3 LS, 1.6, 1.6 Mayfair HLS, 1.6 MG, 2.0 EFi			<b>AK-735013</b>	  	
<b>MINI</b>						<b>01/1967 → 06/1993</b>
Bellow, steering	1000, 1000 Mayfair, 1000 Mayfair Sport, 1100 Special, 1275 GT, 850	with clamps		<b>LM-10035S</b>		d1=10; d2=44; L [mm]=120
<b>MONTEGO (XE)</b>						<b>04/1984 → 08/1988</b>
Dust Cover Kit, shock absorber	1.3, 1.6 LS,HL, 2.0, 2.0 Mayfair, 2.0 Turbo			<b>AK-735013</b>	  	
<b>MONTEGO Estate (XE)</b>						<b>10/1984 → 08/1991</b>
Dust Cover Kit, shock absorber	1.6 LS, 2.0, 2.0 HLI			<b>AK-735013</b>	  	



Article Description





Article Nr.

Fitting Position



**Y10**

03/1985 → 10/1995

Dust Cover Kit, shock absorber	All Models		<b>AK-735005</b>	 ⊕ ⊖	
Control Arm-/Trailing Arm Bush	All Models		<b>G9-506</b>	 ⊕ ⊖	H=37; d=9,2; D1=25; D2=36





**Article Description****Article Nr.****Fitting Position**

<b>1 (E81)</b>			<b>09/2006 → 09/2012</b>		
Dust Cover Kit, shock absorber	116 i, 118 d, 118 i, 120 d, 120 i	<b>ST</b>	<b>AK-735406</b>		H=136, 86
Dust Cover Kit, shock absorber	116 d, 116 i, 118 d, 118 i, 120 d, 120 i, 123 d, 130 i	12/2007 →; <b>ST</b>	<b>AK-735421</b>		
Dust Cover Kit, shock absorber	116 d, 116 i, 118 d, 118 i, 120 d, 120 i, 123 d, 130 i	<b>ST</b>	<b>AK-735424</b>		
Dust Cover Kit, shock absorber	116 i, 118 d, 118 i, 120 d, 120 i, 123 d, 130 i	<b>ST</b>	<b>AK-735427</b>		H=228
Alternator Freewheel Clutch	116 i	N45	<b>F5-1051</b>		
Alternator Freewheel Clutch	116 i	N45	<b>F5-1053</b>		
Alternator Freewheel Clutch	130 i		<b>F5-1053</b>		
Top Strut Mounting	116 d, 116 i, 118 d, 118 i, 120 d, 120 i, 123 d, 130 i		<b>F8-5433</b>		
Control Arm-/Trailing Arm Bush	116 d, 116 i, 118 d, 118 i, 120 d, 120 i, 123 d, 130 i		<b>F8-6250</b>		H=55; d=14; D=47
Control Arm-/Trailing Arm Bush	116 d, 116 i, 118 d, 118 i, 120 d, 120 i, 123 d, 130 i		<b>F8-6252</b>		H1=49.5; H2=33; d=12.2; D=45.3
Mounting, axle bracket	116 d, 116 i, 118 d, 118 i, 120 d, 120 i, 123 d, 130 i		<b>F8-6476</b>		
Protective Cap/Bellow, shock absorber	116 d, 116 i, 118 d, 118 i, 120 d, 120 i, 123 d, 130 i	Universal	<b>F8-6545</b>		H=140
Control Arm-/Trailing Arm Bush	116 d, 116 i, 118 d, 118 i, 120 d, 120 i, 123 d, 130 i		<b>F8-6724</b>		d=12; L1=64.5; L2=76; D=70
Joint, propshaft	123 d		<b>F8-6764</b>		d=44.5; D=155; Thick./Strength 1 [mm]=30
Joint, propshaft	116 d, 118 d, 120 d, 130 i		<b>F8-6768</b>		
Engine Mounting	130 i		<b>F8-6998</b>		
Engine Mounting	116 d, 118 d, 120 d	Aluminium	<b>F8-6999</b>		
Engine Mounting	116 d, 118 d, 120 d	Aluminium	<b>F8-7000</b>		
Engine Mounting	116 i, 118 i, 120 i		<b>F8-7001</b>		
Engine Mounting	116 i, 118 i, 120 i		<b>F8-7002</b>		
Mounting, axle bracket	116 i, 118 d, 118 i, 120 d, 120 i, 130 i		<b>F8-7145</b>		
Protective Cap/Bellow, shock absorber	116 d, 116 i, 118 d, 118 i, 120 d, 120 i, 123 d, 130 i	Available as universal article: F8-6545	<b>F8-7336</b>		H=136
Rubber Buffer, suspension	116 i, 118 d, 118 i, 120 d, 120 i, 123 d, 130 i	<b>ST</b>	<b>F8-7706</b>		H=228
Rubber Buffer, suspension	116 i		<b>F8-7709</b>		H=218
Rubber Buffer, suspension	116 i, 118 d, 118 i, 120 d, 120 i, 123 d, 130 i	<b>MT</b>	<b>F8-7709</b>		H=218
Top Strut Mounting	116 d, 116 i, 118 d, 118 i, 120 d, 120 i, 123 d, 130 i	Lower Section	<b>F8-7723</b>		
Top Strut Mounting	116 d, 116 i, 118 d, 118 i, 120 d, 120 i, 123 d, 130 i	Upper section	<b>F8-7724</b>		
Rubber Buffer, suspension	116 d, 116 i, 118 d, 118 i, 120 d, 120 i, 123 d, 130 i	12/2007 →; <b>ST</b>	<b>F8-7725</b>		
Rubber Buffer, suspension	116 d, 116 i, 116d, 118 d, 118 i, 120 d, 120 i, 123 d, 130 i	<b>ST</b>	<b>F8-7846</b>		H=85
Stabiliser Mounting	116 d, 116 i, 118 d, 118 i, 120 d, 120 i, 123 d, 130 i		<b>F8-7931</b>		d=26,5
Engine Mounting	120 d, 123 d, 130 i		<b>F8-8174</b>		



Article Description



Article Nr.

Fitting Position



<b>1 (E81)</b>				<b>09/2006 → 09/2012</b>	
Mounting, axle beam	116 d, 118 d, 120 d, 123 d		F8-8230		
<b>1 Coupe (E82)</b>				<b>10/2007 → 10/2013</b>	
Dust Cover Kit, shock absorber	118 d, 120 d, 120 i, 123 d, 125 i, 135 i	ST	AK-735421		
Dust Cover Kit, shock absorber	118 d, 120 d, 120 i, 123 d, 125 i, 135 i	ST	AK-735424		
Alternator Freewheel Clutch	125 i		F5-1053		
Top Strut Mounting	118 d, 120 d, 120 i, 123 d, 125 i, 135 i, M		F8-5433		
Control Arm-/Trailing Arm Bush	118 d, 120 d, 120 i, 123 d, 125 i, 135 i, M		F8-6250		H=55; d=14; D=47
Control Arm-/Trailing Arm Bush	118 d, 120 d, 120 i, 123 d, 125 i, 135 i		F8-6252		H1=49.5; H2=33; d=12.2; D=45.3
Mounting, axle bracket	118 d, 120 d, 120 i, 123 d, 125 i, 135 i		F8-6476		
Protective Cap/Bellow, shock absorber	118 d, 120 d, 120 i, 123 d, 125 i, 135 i	Universal	F8-6545		H=140
Control Arm-/Trailing Arm Bush	118 d, 120 d, 120 i, 123 d, 125 i, 135 i		F8-6724		d=12; L1=64.5; L2=76; D=70
Joint, propshaft	123 d		F8-6764		d=44.5; D=155; Thick./Strength 1 [mm]=30
Joint, propshaft	120 d		F8-6768		
Engine Mounting	125 i, 135 i		F8-6998		
Engine Mounting	118 d, 120 d	Aluminium	F8-6999		
Engine Mounting	118 d, 120 d	Aluminium	F8-7000		
Mounting, axle bracket	125 i, 135 i		F8-7145		
Protective Cap/Bellow, shock absorber	118 d, 120 d, 120 i, 123 d, 125 i, 135 i	Available as universal article: F8-6545	F8-7336		H=136
Top Strut Mounting	118 d, 120 d, 120 i, 123 d, 125 i, 135 i, M	Lower Section	F8-7723		
Top Strut Mounting	118 d, 120 d, 120 i, 123 d, 125 i, 135 i, M	Upper section	F8-7724		
Rubber Buffer, suspension	118 d, 120 d, 120 i, 123 d, 125 i, 135 i	ST	F8-7725		
Rubber Buffer, suspension	All Models	ST	F8-7846		H=85
Stabiliser Mounting	118 d, 120 d, 120 i, 123 d, 125 i, 135 i		F8-7931		d=26,5
Engine Mounting	123 d, 125 i, 135 i		F8-8174		
Mounting, axle beam	120 d, 123 d		F8-8230		
<b>1 (E87)</b>				<b>11/2003 → 09/2012</b>	
Dust Cover Kit, shock absorber	116 i, 118 d, 118 i, 120 d, 120 i	ST	AK-735406		H=136, 86
Dust Cover Kit, shock absorber	116 d, 116 i, 118 d, 118 i, 120 d, 120 i, 123 d, 130 i	ST	AK-735424		
Dust Cover Kit, shock absorber	116 i, 118 d, 118 i, 120 d, 120 i, 130 i	ST	AK-735426		
Dust Cover Kit, shock absorber	116 d, 116 i, 118 d, 118 i, 120 d, 120 i, 123 d, 130 i	ST	AK-735427		H=228
Dust Cover Kit, shock absorber	116 i, 118 d, 118 i, 120 d, 120 i, 130 i	04/2005 →; ST	AK-735427		H=228

<b>AK-735406</b>	<b>AK-735421</b>	<b>AK-735424</b>	<b>AK-735426</b>	<b>AK-735427</b>	<b>F5-1051</b>	<b>F5-1053</b>
Ref.Nr.: 3133-1094750	Ref.Nr.: 33503411995	Ref.Nr.: 31331094749	Ref.Nr.: 33536764407	Ref.Nr.: 33536771381	Ref.Nr.: 12317516099	Ref.Nr.: 12314466273
<b>F8-5433</b>	<b>F8-6250</b>	<b>F8-6252</b>	<b>F8-6476</b>	<b>F8-6545</b>	<b>F8-6724</b>	<b>F8-6764</b>
Ref.Nr.: 31331094616	Ref.Nr.: 33326775552	Ref.Nr.: 33326763473-PA	Ref.Nr.: 33326763092	Ref.Nr.: 0146239	Ref.Nr.: 31120393540	Ref.Nr.: 26117542238
<b>F8-6768</b>	<b>F8-6998</b>	<b>F8-6999</b>	<b>F8-7000</b>	<b>F8-7145</b>	<b>F8-7336</b>	<b>F8-7723</b>
Ref.Nr.: 26117527392	Ref.Nr.: 22116760330	Ref.Nr.: 22116768799	Ref.Nr.: 22116768800	Ref.Nr.: 33316758260	Ref.Nr.: 31331094749	Ref.Nr.: 33506771738

**Article Description****Article Nr.****Fitting Position****1 (E87) 11/2003 → 09/2012**

Alternator Freewheel Clutch	116 i	N45	<b>F5-1051</b>		
Alternator Freewheel Clutch	116 i	N45	<b>F5-1053</b>		
Alternator Freewheel Clutch	130 i		<b>F5-1053</b>		
Top Strut Mounting	116 d, 116 i, 118 d, 118 i, 120 d, 120 i, 123 d, 130 i		<b>F8-5433</b>		
Control Arm-/Trailing Arm Bush	116 d, 116 i, 116d, 118 d, 118 i, 120 d, 120 i, 123 d, 130 i		<b>F8-6250</b>		H=55; d=14; D=47
Control Arm-/Trailing Arm Bush	116 d, 116 i, 118 d, 118 i, 120 d, 120 i, 123 d, 130 i		<b>F8-6252</b>		H1=49.5; H2=33; d=12.2; D=45.3
Mounting, axle bracket	116 d, 116 i, 118 d, 118 i, 120 d, 120 i, 123 d, 130 i		<b>F8-6476</b>		
Rubber Buffer, suspension	116 i, 118 d, 118 i, 120 d, 120 i	<b>ST</b>	<b>F8-6542</b>		H=86
Protective Cap/Bellow, shock absorber	116 d, 116 i, 118 d, 118 i, 120 d, 120 i, 123 d, 130 i	Universal	<b>F8-6545</b>		H=140
Control Arm-/Trailing Arm Bush	116 d, 116 i, 118 d, 118 i, 120 d, 120 i, 123 d, 130 i		<b>F8-6724</b>		d=12; L1=64.5; L2=76; D=70
Joint, propshaft	123 d		<b>F8-6764</b>		d=44.5; D=155; Thick./Strength 1 [mm]=30
Joint, propshaft	116 d, 118 d, 120 d, 130 i		<b>F8-6768</b>		
Engine Mounting	130 i		<b>F8-6998</b>		
Engine Mounting	116 d, 118 d, 120 d	Aluminium	<b>F8-6999</b>		
Engine Mounting	116 d, 118 d, 120 d	Aluminium	<b>F8-7000</b>		
Engine Mounting	116 i, 118 i, 120 i		<b>F8-7001</b>		
Engine Mounting	116 i, 118 i, 120 i		<b>F8-7002</b>		
Mounting, axle bracket	116 i, 118 d, 118 i, 120 d, 120 i, 130 i		<b>F8-7145</b>		
Protective Cap/Bellow, shock absorber	116 d, 116 i, 118 d, 118 i, 120 d, 120 i, 123 d, 130 i	Available as universal article: F8-6545	<b>F8-7336</b>		H=136
Rubber Buffer, suspension	116 d, 116 i, 118 d, 118 i, 120 d, 120 i, 123 d, 130 i	<b>ST</b>	<b>F8-7706</b>		H=228
Rubber Buffer, suspension	116 i, 118 d, 118 i, 120 d, 120 i, 130 i	04/2005 →; <b>ST</b>	<b>F8-7706</b>		H=228
Rubber Buffer, suspension	116 d, 116 i, 116d, 118 d, 118 i, 120 d, 120 i, 123 d, 130 i	<b>MT</b>	<b>F8-7709</b>		H=218
Rubber Buffer, suspension	116 d, 116 i, 118 d, 118 i, 120 d, 120 i, 123 d, 130 i	<b>SP</b>	<b>F8-7709</b>		H=218
Top Strut Mounting	116 d, 116 i, 118 d, 118 i, 120 d, 120 i, 123 d, 130 i	Lower Section	<b>F8-7723</b>		
Top Strut Mounting	116 d, 116 i, 118 d, 118 i, 120 d, 120 i, 123 d, 130 i	Upper section	<b>F8-7724</b>		
Rubber Buffer, suspension	116 d, 116d, 123 d, 130 i	<b>ST</b>	<b>F8-7846</b>		H=85
Rubber Buffer, suspension	116 i, 118 d, 118 i, 120 d, 120 i	05/2005 →; <b>ST</b>	<b>F8-7846</b>		H=85

**1 Convertible (E88) 03/2008 → 12/2013**

Dust Cover Kit, shock absorber	118 d, 118 i, 120 d, 120 i, 123 d, 125 i, 135 i	<b>ST</b>	<b>AK-735421</b>		
Dust Cover Kit, shock absorber	118 d, 118 i, 120 d, 120 i, 123 d, 125 i, 135 i	<b>ST</b>	<b>AK-735424</b>		
Alternator Freewheel Clutch	120 i		<b>F5-1051</b>		

<b>AK-735421</b>	<b>AK-735424</b>	<b>F5-1051</b>	<b>F5-1053</b>	<b>F8-5433</b>	<b>F8-6250</b>	<b>F8-6252</b>
Ref.Nr.: 33503411995	Ref.Nr.: 31331094749	Ref.Nr.: 12317516099	Ref.Nr.: 12314466273	Ref.Nr.: 31331094616	Ref.Nr.: 33326775552	Ref.Nr.: 33326763473-PA
<b>F8-6476</b>	<b>F8-6542</b>	<b>F8-6545</b>	<b>F8-6724</b>	<b>F8-6764</b>	<b>F8-6768</b>	<b>F8-6998</b>
Ref.Nr.: 33326763092	Ref.Nr.: 1094750	Ref.Nr.: 0146239	Ref.Nr.: 31120393540	Ref.Nr.: 26117542238	Ref.Nr.: 26117527392	Ref.Nr.: 22116760330
<b>F8-6999</b>	<b>F8-7000</b>	<b>F8-7001</b>	<b>F8-7002</b>	<b>F8-7145</b>	<b>F8-7336</b>	<b>F8-7706</b>
Ref.Nr.: 22116768799	Ref.Nr.: 22116768800	Ref.Nr.: 22116768852	Ref.Nr.: 22116768853	Ref.Nr.: 33316758260	Ref.Nr.: 31331094749	Ref.Nr.: 33536771381

Article Description



Article Nr.

Fitting Position



**1 Convertible (E88)**

03/2008 → 12/2013

Alternator Freewheel Clutch	120 i, 125 i		<b>F5-1053</b>		
Top Strut Mounting	118 d, 118 i, 120 d, 120 i, 123 d, 125 i, 135 i		<b>F8-5433</b>		
Control Arm-/Trailing Arm Bush	118 d, 118 i, 120 d, 120 i, 123 d, 125 i, 135 i		<b>F8-6250</b>		H=55; d=14; D=47
Control Arm-/Trailing Arm Bush	118 d, 118 i, 120 d, 120 i, 123 d, 125 i, 135 i		<b>F8-6252</b>		H1=49.5; H2=33; d=12.2; D=45.3
Mounting, axle bracket	118 d, 118 i, 120 d, 120 i, 123 d, 125 i, 135 i		<b>F8-6476</b>		
Protective Cap/Bellow, shock absorber	118 d, 118 i, 120 d, 120 i, 123 d, 125 i, 135 i	Universal	<b>F8-6545</b>		H=140
Control Arm-/Trailing Arm Bush	118 d, 118 i, 120 d, 120 i, 123 d, 125 i, 135 i		<b>F8-6724</b>		d=12; L1=64.5; L2=76; D=70
Joint, propshaft	123 d		<b>F8-6764</b>		d=44.5; D=155; Thick./Strength 1 [mm]=30
Joint, propshaft	118 d, 120 d		<b>F8-6768</b>		
Engine Mounting	125 i, 135 i		<b>F8-6998</b>		
Engine Mounting	118 d, 120 d	Aluminium	<b>F8-6999</b>		
Engine Mounting	118 d, 120 d	Aluminium	<b>F8-7000</b>		
Mounting, axle bracket	118 i, 120 i, 125 i, 135 i		<b>F8-7145</b>		
Protective Cap/Bellow, shock absorber	118 d, 118 i, 120 d, 120 i, 123 d, 125 i, 135 i	Available as universal article: F8-6545	<b>F8-7336</b>		H=136
Top Strut Mounting	118 d, 118 i, 120 d, 120 i, 123 d, 125 i, 135 i	Lower Section	<b>F8-7723</b>		
Top Strut Mounting	118 d, 118 i, 120 d, 120 i, 123 d, 125 i, 135 i	Upper section	<b>F8-7724</b>		
Rubber Buffer, suspension	118 d, 118 i, 120 d, 120 i, 123 d, 125 i, 135 i	<b>ST</b>	<b>F8-7725</b>		
Rubber Buffer, suspension	118 d, 118 i, 118i, 120 d, 120 i, 123 d, 125 i, 135 i	<b>ST</b>	<b>F8-7846</b>		H=85
Stabiliser Mounting	118 d, 118 i, 120 d, 120 i, 123 d, 125 i, 135 i		<b>F8-7931</b>		d=26,5
Engine Mounting	123 d, 125 i, 135 i		<b>F8-8174</b>		
Mounting, axle beam	118 d, 120 d, 123 d		<b>F8-8230</b>		

**1 (F20)**

11/2010 →

Dust Cover Kit, shock absorber	114 d, 114 i, 116 d, 116 i, 120 d, 125 d, 125 i	SA CodeS2VFA→	<b>AK-735452</b>		
Dust Cover Kit, shock absorber	114 d, 114 i, 116 d, 116 i, 120 d, 125 d, 125 i	SA CodeS2VFA→;	<b>AK-735452</b>		
Control Arm-/Trailing Arm Bush	114 d, 114 i, 116 d, 116 i, 118 d, 118 i, 120 d, 120 d xDrive, 125 d, 125 i, M 135 i, M 135 i xDrive		<b>F8-6250</b>		H=55; d=14; D=47
Protective Cap/Bellow, shock absorber	114 d, 114 i, 116 d, 116 i, 118 d, 118 i, 120 d, 120 d xDrive, 125 d, 125 i, M 135 i, M 135 i xDrive		<b>F8-7485</b>		H=216
Control Arm-/Trailing Arm Bush	114 d, 114 i, 116 d, 116 i, 118 d, 118 i, 120 d, 125 d, 125 i, M 135 i		<b>F8-8092</b>		H1=95; H2=70; d=12.2; D=70.3

**1 (F21)**

12/2011 →

Dust Cover Kit, shock absorber	114 d, 114 i, 116 d, 116 i, 118 d, 118 i, 120 d, 125 d, 125 i	SA CodeS2VFA→	<b>AK-735452</b>		
--------------------------------	---	---------------	------------------	--	--

<b>AK-735452</b>	<b>F5-1053</b>	<b>F8-5433</b>	<b>F8-6250</b>	<b>F8-6252</b>	<b>F8-6476</b>	<b>F8-6545</b>
Ref.Nr.: 31306791712	Ref.Nr.: 12314466273	Ref.Nr.: 31331094616	Ref.Nr.: 33326775552	Ref.Nr.: 33326763473-PA	Ref.Nr.: 33326763092	Ref.Nr.: 0146239
<b>F8-6724</b>	<b>F8-6764</b>	<b>F8-6768</b>	<b>F8-6998</b>	<b>F8-6999</b>	<b>F8-7000</b>	<b>F8-7145</b>
Ref.Nr.: 31120393540	Ref.Nr.: 26117542238	Ref.Nr.: 26117527392	Ref.Nr.: 22116760330	Ref.Nr.: 22116768799	Ref.Nr.: 22116768800	Ref.Nr.: 33316758260
<b>F8-7336</b>	<b>F8-7485</b>	<b>F8-7723</b>	<b>F8-7724</b>	<b>F8-7725</b>	<b>F8-7846</b>	<b>F8-7931</b>
Ref.Nr.: 31331094749	Ref.Nr.: 31306791712	Ref.Nr.: 33506771738	Ref.Nr.: 33506771737	Ref.Nr.: 33536767334	Ref.Nr.: 31336771380	Ref.Nr.: 31356765574

**Article Description****Article Nr.****Fitting Position**

<b>1 (F21)</b>			<b>12/2011 →</b>		
Dust Cover Kit, shock absorber	114 d, 114 i, 116 d, 116 i, 118 d, 118 i, 120 d, 125 d, 125 i	SA CodeS2VFA→;	<b>AK-735452</b>		
Protective Cap/Bellow, shock absorber	114 d, 114 i, 116 d, 116 i, 118 d, 118 d xDrive, 118 i, 120 d, 120 d xDrive, 125 d, 125 i, M 135 i, M 135 i xDrive		<b>F8-7485</b>		H=216
Control Arm-/Trailing Arm Bush	114 d, 114 i, 116 d, 116 i, 118 d, 118 i, 120 d, 125 d, 125 i, M 135 i		<b>F8-8092</b>		H1=95; H2=70; d=12,2; D=70,3
<b>2 Coupe (F22, F87)</b>			<b>10/2013 →</b>		
Control Arm-/Trailing Arm Bush	218 d, 220 d, 220 i, 225 d, 228 i, M 235 i, M 235 i xDrive		<b>F8-8092</b>		H1=95; H2=70; d=12,2; D=70,3
<b>3 (E21)</b>			<b>06/1975 → 03/1984</b>		
Dust Cover Kit, shock absorber	All Models		<b>AK-735004</b>		
Dust Cover Kit, shock absorber	All Models		<b>AK-735006</b>		
Engine Mounting	320/6, 323 i	08/1978 →	<b>F8-5432</b>		H=48; D=70; Thread Measurement 1: M10; Thread Measurement 2: M10
Engine Mounting	320/6		<b>F8-6757</b>		H=48; D=69; Thread Measurement 1: M10; Thread Measurement 2: M10
Engine Mounting	323 i		<b>F8-6757</b>		H=48; D=69; Thread Measurement 1: M10; Thread Measurement 2: M10
Mounting, axle beam	All Models	Bearing Type: Soft Version	<b>F8-7014</b>		
<b>3 (E30)</b>			<b>09/1982 → 01/1992</b>		
Dust Cover Kit, shock absorber	315, 316, 316 i, 318 i, 318 is, 320 i, 323 i, 324 d, 324 td, 325 e 2.7, 325 i		<b>AK-735004</b>		
Dust Cover Kit, shock absorber	315		<b>AK-735006</b>		
Mounting, transfer gear	316, 316 i, 318 i, 318 is, 320 i, 323 i, 324 d, 324 td, 325 e 2.7, 325 i, 325 i X, M3 2.3		<b>F7-2041</b>		H1=30; H2=34; D=85
Mounting, axle beam	316, 316 i, 318 i, 318 is, 320 i, 323 i, 324 d, 324 td, 325 e 2.7, 325 i, 325 i X, M3 2.3		<b>F8-5003</b>		H=104; d=15; D1=59; D2=76
Control Arm-/Trailing Arm Bush	316, 316 i, 318 i, 318 is		<b>F8-5069</b>		H=33; d=18; D=60
Stabiliser Mounting	316 i, 318 i, 318 is, 320 i, 324 td, 325 e 2.7, 325 i		<b>F8-5117</b>		H=61; d=20; D=45
Stabiliser Mounting	316, 318 i, 320 i, 323 i	03/1985 →	<b>F8-5117</b>		H=61; d=20; D=45
Stabiliser Mounting	316, 316 i, 318 i, 320 i, 323 i, 324 d, 325 e 2.7		<b>F8-5118</b>		d=18.5; D=45; Total Br. Drum Height [mm]=61
Top Strut Mounting	315, 316, 316 i, 318 i, 318 is, 320 i, 323 i, 324 d, 324 td, 325 e 2.7, 325 i, 325 i X, M3 2.3		<b>F8-5417</b>		
Top Strut Mounting	315, 316, 316 i, 318 i, 318 is, 320 i, 323 i, 324 d, 324 td, 325 e 2.7, 325 i, M3 2.3		<b>F8-5419</b>		Bolt Distance [mm]=87; d=14, 31; D=130

<b>AK-735004</b>	<b>AK-735006</b>	<b>AK-735452</b>	<b>F7-2041</b>	<b>F8-5003</b>	<b>F8-5069</b>	<b>F8-5117</b>
Ref.Nr.:	Ref.Nr.:	Ref.Nr.: 31306791712	Ref.Nr.: 33171135242	Ref.Nr.: 33311129144	Ref.Nr.: 31129058814	Ref.Nr.: 31351129139
<b>F8-5118</b>	<b>F8-5417</b>	<b>F8-5419</b>	<b>F8-5432</b>	<b>F8-6757</b>	<b>F8-7014</b>	<b>F8-7485</b>
Ref.Nr.: 31351126774	Ref.Nr.: 33521125554	Ref.Nr.: 31331124508	Ref.Nr.: 11811132321	Ref.Nr.: 11811132323	Ref.Nr.: 33331118569	Ref.Nr.: 31306791712
<b>F8-8092</b>						
Ref.Nr.: 31126851255						

**Article Description**

**Article Nr.**
**Fitting Position**

<b>3 (E30)</b>				<b>09/1982 → 01/1992</b>	
Engine Mounting	320 i, 323 i, 324 d, 324 td, 325 e 2.7, 325 i		<b>F8-5432</b>		H=48; D=70; Thread Measurement 1: M10; Thread Measurement 2: M10
Rubber Buffer, suspension	315, 316, 316 i, 318 i, 318 is, 320 i, 323 i, 324 d, 324 td, 325 e 2.7, 325 i, 325 i X, M3 2.3		<b>F8-5690</b>		H=85
Control Arm-/Trailing Arm Bush	316, 316 i, 318 i, 318 is	with holder;	<b>F8-6105</b>		
Control Arm-/Trailing Arm Bush	316, 316 i, 318 i, 318 is	with holder;	<b>F8-6106</b>		
Control Arm-/Trailing Arm Bush	316, 316 i, 318 i, 318 is		<b>F8-6107</b>		
Control Arm-/Trailing Arm Bush	320 i, 320 is, 323 i		<b>F8-6107</b>		
Control Arm-/Trailing Arm Bush	316, 316 i, 318 i, 318 is		<b>F8-6108</b>		
Control Arm-/Trailing Arm Bush	320 i, 320 is, 323 i		<b>F8-6108</b>		
Control Arm-/Trailing Arm Bush	320 i, 320 is, 323 i, 324 d, 324 td, 325 e 2.7, 325 i		<b>F8-6109</b>		
Control Arm-/Trailing Arm Bush	320 i, 320 is, 323 i, 324 d, 324 td, 325 e 2.7, 325 i		<b>F8-6110</b>		
Mounting, automatic transmission	316 i, 318 i		<b>F8-6242</b>		H1=34; H2=69; D1=36; D2=50
Engine Mounting	320 i, 325 e 2.7, 325 i		<b>F8-6757</b>		H=48; D=69; Thread Measurement 1: M10; Thread Measurement 2: M10
Mounting, automatic transmission	320 i	09/1983 →	<b>F8-7022</b>		
Mounting, automatic transmission	320 i, 323 i, 324 d, 324 td, 325 e 2.7, 325 i		<b>F8-7022</b>		
Protective Cap/Bellow, shock absorber	316, 316 i, 318 i, 318 is, 320 i, 320 is, 323 i, 324 d, 324 td, 325 e 2.7, 325 i, 325 i X, M3 2.3, M3 EVO I 2.3, M3 EVO II 2.5		<b>F8-7685</b>		H=91
Control Arm-/Trailing Arm Bush	316, 316 i, 318 i, 318 is		<b>G9-623</b>		H=33; d=18; D=60
Control Arm-/Trailing Arm Bush	320 i, 320 is, 323 i		<b>G9-623</b>		H=33; d=18; D=60
Control Arm-/Trailing Arm Bush	320 i, 320 is, 323 i		<b>G9-624</b>		H=33; d=18; D=60
Control Arm-/Trailing Arm Bush	324 d, 324 td, 325 e 2.7, 325 i		<b>G9-624</b>		H=33; d=18; D=60
Bellow, steering	316, 316 i, 318 i, 318 is, 320 i, 323 i, 324 d, 324 td, 325 e 2.7, 325 i, 325 i X, M3 2.3, M3 EVO I 2.3, M3 EVO II 2.5	with clamps	<b>LM-10052S</b>		d1=37; d2=44; L [mm]=165

<b>AK-735004</b>	<b>F8-5432</b>	<b>F8-5690</b>	<b>F8-6105</b>	<b>F8-6106</b>	<b>F8-6107</b>	<b>F8-6108</b>
Ref.Nr.:	Ref.Nr.: 11811132321	Ref.Nr.: 31331125215	Ref.Nr.: 31121128773-PA	Ref.Nr.: 31121136112-PA	Ref.Nr.: 31129058815S1	Ref.Nr.: 31129058815S2
<b>F8-6109</b>	<b>F8-6110</b>	<b>F8-6242</b>	<b>F8-6757</b>	<b>F8-7022</b>	<b>F8-7685</b>	<b>G9-623</b>
Ref.Nr.: 31129058931S1	Ref.Nr.: 31129058931S2	Ref.Nr.: 23711133487	Ref.Nr.: 11811132323	Ref.Nr.: 24711128372	Ref.Nr.: 1134314	Ref.Nr.: 31121127378
<b>G9-624</b>	<b>LM-10052S</b>					
Ref.Nr.: 31121130123	Ref.Nr.: 32111127104					

**Article Description****Article Nr.****Fitting Position****3 Convertible (E30)****12/1985 → 10/1993**

Dust Cover Kit, shock absorber	318 i, 320 i, 325 i		<b>AK-735004</b>						
Mounting, transfer gear	318 i, 320 i, 325 i, M3 2.3		<b>F7-2041</b>					H1=30; H2=34; D=85	
Mounting, axle beam	318 i, 320 i, 325 i, M3 2.3		<b>F8-5003</b>					H=104; d=15; D1=59; D2=76	
Control Arm-/Trailing Arm Bush	318 i		<b>F8-5069</b>					H=33; d=18; D=60	
Stabiliser Mounting	318 i		<b>F8-5117</b>					H=61; d=20; D=45	
Top Strut Mounting	318 i, 320 i, 325 i		<b>F8-5417</b>						
Top Strut Mounting	318 i, 320 i, 325 i, M3 2.3		<b>F8-5419</b>					Bolt Distance [mm]=87; d=14, 31; D=130	
Engine Mounting	325 i		<b>F8-5432</b>					H=48; D=70; Thread Measurement 1: M10; Thread Measurement 2: M10	
Rubber Buffer, suspension	318 i, 320 i, 325 i		<b>F8-5690</b>					H=85	
Control Arm-/Trailing Arm Bush	316 i, 318 i	with holder;	<b>F8-6105</b>						
Control Arm-/Trailing Arm Bush	316 i, 318 i	with holder;	<b>F8-6106</b>						
Control Arm-/Trailing Arm Bush	316 i, 318 i		<b>F8-6107</b>						
Control Arm-/Trailing Arm Bush	320 i		<b>F8-6107</b>						
Control Arm-/Trailing Arm Bush	316 i, 318 i		<b>F8-6108</b>						
Control Arm-/Trailing Arm Bush	320 i		<b>F8-6108</b>						
Control Arm-/Trailing Arm Bush	320 i, 325 i		<b>F8-6109</b>						
Control Arm-/Trailing Arm Bush	320 i, 325 i		<b>F8-6110</b>						
Mounting, automatic transmission	316 i, 318 i		<b>F8-6242</b>					H1=34; H2=69; D1=36; D2=50	
Engine Mounting	325 i		<b>F8-6757</b>					H=48; D=69; Thread Measurement 1: M10; Thread Measurement 2: M10	
Mounting, automatic transmission	320 i, 325 i		<b>F8-7022</b>						
Protective Cap/Bellow, shock absorber	316 i, 318 i, 320 i, 325 i, M3 2.3		<b>F8-7685</b>					H=91	
Control Arm-/Trailing Arm Bush	318 i		<b>G9-623</b>						H=33; d=18; D=60
Control Arm-/Trailing Arm Bush	320 i		<b>G9-623</b>						H=33; d=18; D=60
Control Arm-/Trailing Arm Bush	318 i, 320 i, 325 i		<b>G9-624</b>						H=33; d=18; D=60

<b>AK-735004</b>	<b>F7-2041</b>	<b>F8-5003</b>	<b>F8-5069</b>	<b>F8-5117</b>	<b>F8-5417</b>	<b>F8-5419</b>
Ref.Nr.:	Ref.Nr.: 33171135242	Ref.Nr.: 33311129144	Ref.Nr.: 31129058814	Ref.Nr.: 31351129139	Ref.Nr.: 33521125554	Ref.Nr.: 31331124508
<b>F8-5432</b>	<b>F8-5690</b>	<b>F8-6105</b>	<b>F8-6106</b>	<b>F8-6107</b>	<b>F8-6108</b>	<b>F8-6109</b>
Ref.Nr.: 11811132321	Ref.Nr.: 31331125215	Ref.Nr.: 31121128773-PA	Ref.Nr.: 31121136112-PA	Ref.Nr.: 31129058815S1	Ref.Nr.: 31129058815S2	Ref.Nr.: 31129058931S1
<b>F8-6110</b>	<b>F8-6242</b>	<b>F8-6757</b>	<b>F8-7022</b>	<b>F8-7685</b>	<b>G9-623</b>	<b>G9-624</b>
Ref.Nr.: 31129058931S2	Ref.Nr.: 23711133487	Ref.Nr.: 11811132323	Ref.Nr.: 24711128372	Ref.Nr.: 1134314	Ref.Nr.: 31121127378	Ref.Nr.: 31121130123

Article Description



Article Nr.

Fitting Position



<b>3 Convertible (E30)</b>			<b>12/1985 → 10/1993</b>	
Bellow, steering	318 i, 320 i, 325 i, M3 2.3	with clamps	LM-10052S	d1=37; d2=44; L [mm]=165
<b>3 Touring (E30)</b>			<b>07/1987 → 06/1994</b>	
Dust Cover Kit, shock absorber	316 i, 318 i, 320 i, 324 td, 325 i, 325 i X		AK-735004	
Mounting, transfer gear	316 i, 318 i, 320 i, 324 td, 325 i, 325 i X		F7-2041	H1=30; H2=34; D=85
Mounting, axle beam	316 i, 318 i, 320 i, 324 td, 325 i, 325 i X		F8-5003	H=104; d=15; D1=59; D2=76
Control Arm-/Trailing Arm Bush	316 i, 318 i	☼	F8-5069	H=33; d=18; D=60
Stabiliser Mounting	316 i, 318 i, 320 i, 324 td, 325 i		F8-5117	H=61; d=20; D=45
Stabiliser Mounting	316 i, 318 i, 320 i		F8-5118	d=18.5; D=45; Total Br. Drum Height [mm]=61
Top Strut Mounting	316 i, 318 i, 324 td, 325 i, 325 i X		F8-5417	
Top Strut Mounting	320 i	SP; K	F8-5417	
Top Strut Mounting	316 i, 318 i, 320 i, 324 td, 325 i	☼	F8-5419	Bolt Distance [mm]=87; d=14, 31; D=130
Engine Mounting	320 i, 324 td, 325 i		F8-5432	H=48; D=70; Thread Measurement 1: M10; Thread Measurement 2: M10
Rubber Buffer, suspension	316 i, 318 i, 320 i, 324 td, 325 i, 325 i X		F8-5690	H=85
Control Arm-/Trailing Arm Bush	316 i, 318 i	with holder; ☼	F8-6105	
Control Arm-/Trailing Arm Bush	316 i, 318 i	with holder; ☼	F8-6106	
Control Arm-/Trailing Arm Bush	316 i, 318 i	☼	F8-6107	
Control Arm-/Trailing Arm Bush	320 i	☼	F8-6107	
Control Arm-/Trailing Arm Bush	316 i, 318 i	☼	F8-6108	
Control Arm-/Trailing Arm Bush	320 i	☼	F8-6108	
Control Arm-/Trailing Arm Bush	320 i, 324 td, 325 i		F8-6109	
Control Arm-/Trailing Arm Bush	320 i, 324 td, 325 i		F8-6110	
Mounting, automatic transmission	316 i, 318 i		F8-6242	H1=34; H2=69; D1=36; D2=50
Mounting, automatic transmission	320 i, 324 td, 325 i		F8-7022	
Protective Cap/Bellow, shock absorber	All Models		F8-7685	H=91
Control Arm-/Trailing Arm Bush	316 i, 318 i	☼	G9-623	H=33; d=18; D=60

<b>AK-735004</b>	<b>F7-2041</b>	<b>F8-5003</b>	<b>F8-5069</b>	<b>F8-5117</b>	<b>F8-5118</b>	<b>F8-5417</b>
Ref.Nr.:	Ref.Nr.: 33171135242	Ref.Nr.: 33311129144	Ref.Nr.: 31129058814	Ref.Nr.: 31351129139	Ref.Nr.: 31351126774	Ref.Nr.: 33521125554
<b>F8-5419</b>	<b>F8-5432</b>	<b>F8-5690</b>	<b>F8-6105</b>	<b>F8-6106</b>	<b>F8-6107</b>	<b>F8-6108</b>
Ref.Nr.: 31331124508	Ref.Nr.: 11811132321	Ref.Nr.: 31331125215	Ref.Nr.: 31121128773-PA	Ref.Nr.: 31121136112-PA	Ref.Nr.: 31129058815S1	Ref.Nr.: 31129058815S2
<b>F8-6109</b>	<b>F8-6110</b>	<b>F8-6242</b>	<b>F8-7022</b>	<b>F8-7685</b>	<b>G9-623</b>	<b>LM-10052S</b>
Ref.Nr.: 31129058931S1	Ref.Nr.: 31129058931S2	Ref.Nr.: 23711133487	Ref.Nr.: 24711128372	Ref.Nr.: 1134314	Ref.Nr.: 31121127378	Ref.Nr.: 32111127104



**Article Description****Article Nr.****Fitting Position****3 Touring (E30)****07/1987 → 06/1994**

Control Arm-/Trailing Arm Bush	320 i		<b>G9-623</b>		H=33; d=18; D=60
Control Arm-/Trailing Arm Bush	320 i		<b>G9-624</b>		H=33; d=18; D=60
Control Arm-/Trailing Arm Bush	324 td, 325 i		<b>G9-624</b>		H=33; d=18; D=60
Bellow, steering	All Models	with clamps	<b>LM-10052S</b>		d1=37; d2=44; L [mm]=165

**3 (E36)****09/1990 → 02/1998**

Dust Cover Kit, shock absorber	316 i, 318 i, 318 is, 318 tds, 320 i, 323 i 2.5, 325 i, 325 td, 325 tds, 328 i		<b>AK-735004</b>		
Dust Cover Kit, shock absorber	All Models	<b>ST</b>	<b>AK-735126</b>		
Mounting, transfer gear	318 is, M3 3.2		<b>F7-2041</b>		H1=30; H2=34; D=85
Top Strut Mounting	All Models		<b>F8-5030</b>		H=35; d=10
Bellow, steering	316 i, 318 i, 318 is, 320 i, 323 i 2.5, 325 i, 325 td, 325 tds, M3 3.2		<b>F8-5171</b>		Total Br. Drum Height [mm]=185
Control Arm-/Trailing Arm Bush	316 i, 318 i, 318 is, 318 tds, 320 i, 323 i 2.5, 325 i, 325 td, 325 tds, 328 i, M3 3.0		<b>F8-5311</b>		H=49; d=12; D=61
Tie Bar Bush	316 i, 318 i, 320 i, 325 i, 325 td, 325 tds		<b>F8-5321</b>		H=57; d=12.2; D=45.4
Control Arm-/Trailing Arm Bush	316 i, 318 i, 320 i, 325 i, 325 td, 325 tds		<b>F8-5322</b>		H=56.5; d=12.1; D=35.6
Repair Set, axle beam	316 i, 318 i, 320 i, 323 i 2.5, 325 i, 325 td, 325 tds		<b>F8-5323</b>		d=12.5; D=60.5
Repair Set, axle beam	316 i, 318 i, 320 i, 323 i 2.5, 325 i, 325 td, 325 tds		<b>F8-5324</b>		d=15.5; D=62.5
Engine Mounting	320 i, 323 i 2.5, 325 i, 328 i		<b>F8-5348</b>		
Engine Mounting	318 tds		<b>F8-5427</b>		
Engine Mounting	316 i, 318 i, 318 is, 318 tds		<b>F8-5428</b>		
Engine Mounting	325 td, 325 tds		<b>F8-5430</b>		
Top Strut Mounting	316 i, 318 i, 318 is, 318 tds, 323 i 2.5, 325 tds, 328 i		<b>F8-5506</b>		
Top Strut Mounting	316 i, 318 i, 320 i, 325 i, 325 td	06/1992 →;	<b>F8-5506</b>		
Control Arm-/Trailing Arm Bush	All Models		<b>F8-5632</b>		H=57; d=12; D=45
Stabiliser Mounting	318 i, 318 is, 320 i, 323 i 2.5, 325 i, 325 td, 325 tds, 328 i		<b>F8-5689</b>		d=15; L=40; D=34
Rubber Buffer, suspension	316 i, 318 i, 318 is, 318 tds, 320 i, 323 i 2.5, 325 i, 325 td, 325 tds, 328 i		<b>F8-5690</b>		H=85
Control Arm-/Trailing Arm Bush	316 i, 318 i, 318 is, 318 tds, 320 i, 323 i 2.5, 325 i, 325 td, 325 tds, 328 i, M3 3.0, M3 3.2		<b>F8-5746</b>		H=42, 66.5; d=12; D=35
Mounting, transfer gear	All Models		<b>F8-5839</b>		H=30; D=50
Rubber Buffer, suspension	316 i, 318 i, 318 is, 320 i, 323 i 2.5, 325 i, 325 td, 325 tds, 328 i, M3 3.0, M3 3.2	<b>ST, MT, SP</b>	<b>F8-5963</b>		H=105
Control Arm-/Trailing Arm Bush	316 i, 318 i, 318 is, 318 tds, 320 i, 323 i 2.5, 325 i, 325 td, 325 tds, 328 i		<b>F8-6102</b>		



**Article Description**

**Article Nr.**
**Fitting Position**

<b>3 (E36)</b>		<b>09/1990 → 02/1998</b>	
Control Arm-/Trailing Arm Bush	316 i, 318 i, 318 is, 318 tds, 320 i, 323 i 2.5, 325 i, 325 td, 325 tds, 328 i	F8-6103	
Engine Mounting	M3 3.0, M3 3.2	F8-6215	
Mounting, automatic transmission	316 i, 318 i, 318 is	F8-6242	H1=34; H2=69; D1=36; D2=50
Mounting, automatic transmission	325 td, 325 tds	F8-6491	H=34; D=36, 50; Outer Thread [mm]=M8 x 1,25mm
Joint, propshaft	323 i 2.5, 325 i	12/1994 →,	F8-6762
Mounting, propshaft	316 i, 318 i, 318 is, 318 tds, 320 i		F8-6777
Mounting, propshaft	316 i, 318 i, 323 i 2.5, 325 i, 325 td, 325 tds, 328 i		F8-6777
Mounting, propshaft	316 i, 318 i, 318 is, 320 i		F8-6778
Mounting, propshaft	318 tds		F8-6778
Joint, propshaft	M3 3.0, M3 3.2		F8-6783
Top Strut Mounting	320 i, 325 i, 325 td		F8-7425
Protective Cap/Bellow, shock absorber	All Models		F8-7684
Rubber Buffer, suspension	316 i, 318 i, 318 is, 318 tds, 320 i, 323 i 2.5, 325 i, 325 td, 325 tds, 328 i, M3 3.0, M3 3.2		F8-7700
Protective Cap/Bellow, shock absorber	316 i, 318 i, 318 is, 318 tds, 320 i, 323 i 2.5, 325 i, 325 td, 325 tds, 328 i, M3 3.0, M3 3.2		F8-7727
Protective Cap/Bellow, shock absorber	316 i, 318 i, 318 is, 318 tds, 320 i, 323 i 2.5, 325 tds, 328 i		F8-7738
Protective Cap/Bellow, shock absorber	316 i, 318 i, 320 i, 325 i, 325 td	06/1992 →,	F8-7738
Stabiliser Mounting	316 i		F8-7976
Stabiliser Mounting	316 i, 318 i	10/1991 →	F8-7976
Stabiliser Mounting	318 i, 318 is, 318 tds, 323 i 2.5, 325 td, 325 tds, 328 i		F8-7976
Stabiliser Mounting	320 i, 325 i	10/1991 →,	F8-7976
Engine Mounting	316 i, 318 i, 318 is, 320 i, 323 i 2.5, 325 i, 328 i, M3 3.0, M3 3.2		F8-8174
Control Arm-/Trailing Arm Bush	316 i, 318 i, 318 is, 318 tds, 320 i, 323 i 2.5, 325 i, 325 td, 325 tds	G9-625	H=34; d=18; D=60
Control Arm-/Trailing Arm Bush	316 i, 318 i, 318 is, 318 tds, 320 i, 323 i 2.5, 325 i, 325 td, 325 tds	G9-625S	H=34; d=18; D=60
Bellow, steering	All Models	with clamps;	LM-10011S
<b>3 Convertible (E36)</b>		<b>03/1993 → 04/1999</b>	
Dust Cover Kit, shock absorber	318 i, 320 i, 323 i, 325 i, 328 i	AK-735004	
Dust Cover Kit, shock absorber	All Models		AK-735126
Mounting, transfer gear	M3 3.0, M3 3.2	F7-2041	H1=30; H2=34; D=85



**Article Description****Article Nr.****Fitting Position**

<b>3 Convertible (E36)</b>			<b>03/1993 → 04/1999</b>		
Top Strut Mounting	318 i, 320 i, 323 i, 325 i, 328 i, M3 3.0		<b>F8-5030</b>		H=35; d=10
Bellow, steering	All Models		<b>F8-5171</b>		Total Br. Drum Height [mm]=185
Control Arm-/Trailing Arm Bush	318 i, 320 i, 323 i, 325 i, 328 i, M3 3.0		<b>F8-5311</b>		H=49; d=12; D=61
Tie Bar Bush	318 i, 320 i, 325 i, 328 i		<b>F8-5321</b>		H=57; d=12.2; D=45.4
Control Arm-/Trailing Arm Bush	318 i, 320 i, 325 i, 328 i		<b>F8-5322</b>		H=56.5; d=12.1; D=35.6
Repair Set, axle beam	318 i, 320 i, 323 i, 325 i, 328 i		<b>F8-5323</b>		d=12.5; D=60.5
Repair Set, axle beam	318 i, 320 i, 323 i, 325 i, 328 i		<b>F8-5324</b>		d=15.5; D=62.5
Engine Mounting	320 i, 323 i, 325 i, 328 i		<b>F8-5348</b>		
Engine Mounting	318 i		<b>F8-5428</b>		
Top Strut Mounting	318 i, 320 i, 323 i, 325 i, 328 i		<b>F8-5506</b>		
Control Arm-/Trailing Arm Bush	All Models		<b>F8-5632</b>		H=57; d=12; D=45
Stabiliser Mounting	318 i, 320 i, 323 i, 325 i, 328 i		<b>F8-5689</b>		d=15; L=40; D=34
Rubber Buffer, suspension	318 i, 320 i, 323 i, 325 i, 328 i		<b>F8-5690</b>		H=85
Control Arm-/Trailing Arm Bush	All Models		<b>F8-5746</b>		H=42, 66.5; d=12; D=35
Mounting, transfer gear	All Models		<b>F8-5839</b>		H=30; D=50
Rubber Buffer, suspension	All Models	<b>ST, MT, SP</b>	<b>F8-5963</b>		H=105
Control Arm-/Trailing Arm Bush	318 i, 320 i, 323 i, 325 i, 328 i		<b>F8-6102</b>		
Control Arm-/Trailing Arm Bush	318 i, 320 i, 323 i, 325 i, 328 i		<b>F8-6103</b>		
Engine Mounting	M3 3.0, M3 3.2		<b>F8-6215</b>		
Mounting, automatic transmission	318 i		<b>F8-6242</b>		H1=34; H2=69; D1=36; D2=50
Joint, propshaft	323 i, 325 i	12/1994 →;	<b>F8-6762</b>		d=38; D=106; Thick./Strength 1 [mm]=31
Mounting, propshaft	318 i, 320 i, 325 i		<b>F8-6777</b>		d=30
Mounting, propshaft	323 i, 328 i		<b>F8-6777</b>		d=30
Mounting, propshaft	318 i, 320 i, 325 i		<b>F8-6778</b>		
Joint, propshaft	M3 3.0, M3 3.2		<b>F8-6783</b>		
Protective Cap/Bellow, shock absorber	All Models		<b>F8-7684</b>		H=194
Rubber Buffer, suspension	All Models	<b>SP</b>	<b>F8-7700</b>		H=90
Protective Cap/Bellow, shock absorber	All Models	<b>ST</b>	<b>F8-7727</b>		H=86
Protective Cap/Bellow, shock absorber	318 i, 320 i, 323 i, 325 i, 328 i		<b>F8-7738</b>		H=200

<b>F8-5030</b>	<b>F8-5171</b>	<b>F8-5311</b>	<b>F8-5321</b>	<b>F8-5322</b>	<b>F8-5323</b>	<b>F8-5324</b>
Ref.Nr.: 33504035929	Ref.Nr.: 32111137070	Ref.Nr.: 33321097009	Ref.Nr.: 33321136311	Ref.Nr.: 33321092248	Ref.Nr.: 33319059300	Ref.Nr.: 33319059301
<b>F8-5348</b>	<b>F8-5428</b>	<b>F8-5506</b>	<b>F8-5632</b>	<b>F8-5689</b>	<b>F8-5690</b>	<b>F8-5746</b>
Ref.Nr.: 11811082583	Ref.Nr.: 11811137238	Ref.Nr.: 31336764947	Ref.Nr.: 33321138722	Ref.Nr.: 33551131155	Ref.Nr.: 31331125215	Ref.Nr.: 33321092247
<b>F8-5839</b>	<b>F8-5963</b>	<b>F8-6102</b>	<b>F8-6103</b>	<b>F8-6215</b>	<b>F8-6242</b>	<b>F8-6762</b>
Ref.Nr.: 33171134872	Ref.Nr.: 33531136395	Ref.Nr.: 31121136531	Ref.Nr.: 31121136532	Ref.Nr.: 11817837985	Ref.Nr.: 23711133487	Ref.Nr.: 26111227869

Article Description



Article Nr.

Fitting Position



### 3 Convertible (E36)

03/1993 → 04/1999

Stabiliser Mounting	318 i		F8-7976	⊕ ⊕ ⊕	D=17
Stabiliser Mounting	320 i	M 50, M 52	F8-7976	⊕ ⊕ ⊕	D=17
Stabiliser Mounting	323 i, 328 i	M 52	F8-7976	⊕ ⊕ ⊕	D=17
Stabiliser Mounting	325 i	M 50	F8-7976	⊕ ⊕ ⊕	D=17
Engine Mounting	All Models		F8-8174	⊕ ⊕	
Control Arm-/Trailing Arm Bush	318 i, 320 i, 323 i, 325 i, 328 i		G9-625	⊕ ⊕ ⊕ ↓	H=34; d=18; D=60
Control Arm-/Trailing Arm Bush	318 i, 320 i, 323 i, 325 i, 328 i		G9-625S	⊕ ⊕ ⊕ ↓	H=34; d=18; D=60
Bellow, steering	All Models	with clamps;	LM-10011S		d1=37; d2=51; L [mm]=185

### 3 Compact (E36)

03/1994 → 08/2000

Dust Cover Kit, shock absorber	316 i, 318 tds, 318 ti, 323 ti		AK-735004	⊕ ⊕ ⊕	
Mounting, transfer gear	318 ti		F7-2041		H1=30; H2=34; D=85
Top Strut Mounting	All Models		F8-5030	⊕ ⊕ ⊕	H=35; d=10
Bellow, steering	316 i, 318 ti		F8-5171	⊕ ⊕ ⊕	Total Br. Drum Height [mm]=185
Engine Mounting	323 ti		F8-5348	⊕ ⊕ ⊕	
Engine Mounting	318 tds		F8-5427	⊕	
Engine Mounting	316 g, 316 i, 318 tds, 318 ti		F8-5428	⊕ ⊕	
Top Strut Mounting	All Models		F8-5506	⊕ ⊕ ⊕	
Belt Pulley, crankshaft	323 ti	09/1998 →	F8-5662		
Rubber Buffer, suspension	316 i, 318 tds, 318 ti, 323 ti		F8-5690	⊕ ⊕ ⊕	H=85
Mounting, transfer gear	All Models		F8-5839	⊕ ⊕ ⊕	H=30; D=50
Mounting, axle beam	All Models		F8-6080	⊕ ⊕ ⊕	H=84; d=14; D1=59; D2=77
Control Arm-/Trailing Arm Bush	All Models		F8-6102	⊕	
Control Arm-/Trailing Arm Bush	All Models		F8-6103	⊕	
Mounting, automatic transmission	316 g, 316 i, 318 ti		F8-6242		H1=34; H2=69; D1=36; D2=50
Mounting, propshaft	316 g, 316 i, 318 ti		F8-6777		d=30
Mounting, propshaft	323 ti		F8-6777		d=30
Mounting, propshaft	316 g		F8-6778		
Mounting, propshaft	316 i, 318 ti		F8-6778		
Protective Cap/Bellow, shock absorber	All Models		F8-7727		H=86
Protective Cap/Bellow, shock absorber	All Models		F8-7738	⊕ ⊕ ⊕	H=200
Engine Mounting	316 g, 316 i, 318 ti, 323 ti		F8-8174	⊕ ⊕	



**Article Description****Article Nr.****Fitting Position**

<b>3 Compact (E36)</b>				<b>03/1994 → 08/2000</b>	
Mounting, propshaft	318 tds			<b>F8-8226</b>	
Control Arm-/Trailing Arm Bush	316 i, 318 tds, 318 ti			<b>G9-625</b>	 H=34; d=18; D=60
Control Arm-/Trailing Arm Bush	316 i, 318 tds, 318 ti			<b>G9-625S</b>	 H=34; d=18; D=60
Bellow, steering	All Models	with clamps;		<b>LM-10011S</b>	 d1=37; d2=51; L [mm]=185
<b>3 Coupe (E36)</b>				<b>03/1992 → 04/1999</b>	
Dust Cover Kit, shock absorber	316 i, 318 is, 320 i, 323 i, 325 i, 328 i			<b>AK-735004</b>	
Dust Cover Kit, shock absorber	All Models	<b>ST</b>		<b>AK-735126</b>	
Mounting, transfer gear	318 is, M3 3.0, M3 3.2			<b>F7-2041</b>	 H1=30; H2=34; D=85
Top Strut Mounting	All Models			<b>F8-5030</b>	 H=35; d=10
Bellow, steering	All Models			<b>F8-5171</b>	 Total Br. Drum Height [mm]=185
Control Arm-/Trailing Arm Bush	316 i, 318 is, 320 i, 323 i, 325 i, 328 i, M3 3.0			<b>F8-5311</b>	 H=49; d=12; D=61
Tie Bar Bush	316 i, 320 i, 325 i, 328 i			<b>F8-5321</b>	 H=57; d=12.2; D=45.4
Control Arm-/Trailing Arm Bush	316 i, 320 i, 325 i, 328 i			<b>F8-5322</b>	 H=56.5; d=12.1; D=35.6
Repair Set, axle beam	316 i, 320 i, 323 i, 325 i, 328 i			<b>F8-5323</b>	 d=12.5; D=60.5
Repair Set, axle beam	316 i, 320 i, 323 i, 325 i, 328 i			<b>F8-5324</b>	 d=15.5; D=62.5
Engine Mounting	320 i, 323 i, 325 i, 328 i			<b>F8-5348</b>	
Engine Mounting	316 i, 318 is			<b>F8-5428</b>	
Top Strut Mounting	316 i, 318 is, 323 i, 328 i			<b>F8-5506</b>	
Top Strut Mounting	320 i, 325 i	06/1992 →;		<b>F8-5506</b>	
Control Arm-/Trailing Arm Bush	All Models			<b>F8-5632</b>	 H=57; d=12; D=45
Belt Pulley, crankshaft	323 i, 328 i	09/1998 →		<b>F8-5662</b>	
Stabiliser Mounting	318 is, 320 i, 323 i, 325 i, 328 i			<b>F8-5689</b>	 d=15; L=40; D=34
Rubber Buffer, suspension	316 i, 318 is, 320 i, 323 i, 325 i, 328 i			<b>F8-5690</b>	 H=85
Control Arm-/Trailing Arm Bush	All Models			<b>F8-5746</b>	 H=42, 66.5; d=12; D=35
Mounting, transfer gear	All Models			<b>F8-5839</b>	 H=30; D=50
Rubber Buffer, suspension	All Models	<b>ST, MT, SP</b>		<b>F8-5963</b>	 H=105
Control Arm-/Trailing Arm Bush	316 i, 318 is, 320 i, 323 i, 325 i, 328 i			<b>F8-6102</b>	
Control Arm-/Trailing Arm Bush	316 i, 318 is, 320 i, 323 i, 325 i, 328 i			<b>F8-6103</b>	
Mounting, automatic transmission	316 i, 318 is			<b>F8-6242</b>	 H1=34; H2=69; D1=36; D2=50

<b>AK-735004</b>	<b>AK-735126</b>	<b>F7-2041</b>	<b>F8-5030</b>	<b>F8-5171</b>	<b>F8-5311</b>	<b>F8-5321</b>
Ref.Nr.:	Ref.Nr.: 33521136283	Ref.Nr.: 33171135242	Ref.Nr.: 33504035929	Ref.Nr.: 32111137070	Ref.Nr.: 33321097009	Ref.Nr.: 33321136311
<b>F8-5322</b>	<b>F8-5323</b>	<b>F8-5324</b>	<b>F8-5348</b>	<b>F8-5428</b>	<b>F8-5506</b>	<b>F8-5632</b>
Ref.Nr.: 33321092248	Ref.Nr.: 33319059300	Ref.Nr.: 33319059301	Ref.Nr.: 11811082583	Ref.Nr.: 11811137238	Ref.Nr.: 31336764947	Ref.Nr.: 33321138722
<b>F8-5662</b>	<b>F8-5689</b>	<b>F8-5690</b>	<b>F8-5746</b>	<b>F8-5839</b>	<b>F8-5963</b>	<b>F8-6102</b>
Ref.Nr.: 1 438 995	Ref.Nr.: 33551131155	Ref.Nr.: 31331125215	Ref.Nr.: 33321092247	Ref.Nr.: 33171134872	Ref.Nr.: 33531136395	Ref.Nr.: 31121136531

Article Description



Article Nr.

Fitting Position



### 3 Coupé (E36)

03/1992 → 04/1999

Joint, propshaft	323 i, 325 i	12/1994 →;	<b>F8-6762</b>		d=38; D=106; Thick./Strength 1 [mm]=31
Mounting, propshaft	316 i, 318 is, 320 i, 325 i		<b>F8-6777</b>		d=30
Mounting, propshaft	318 is, 323 i, 328 i		<b>F8-6777</b>		d=30
Mounting, propshaft	316 i, 318 is, 320 i, 325 i		<b>F8-6778</b>		
Joint, propshaft	M3 3.0, M3 3.2		<b>F8-6783</b>		
Top Strut Mounting	320 i, 325 i		<b>F8-7425</b>		
Protective Cap/Bellow, shock absorber	All Models		<b>F8-7684</b>		H=194
Rubber Buffer, suspension	All Models	<b>SP</b>	<b>F8-7700</b>		H=90
Protective Cap/Bellow, shock absorber	All Models	<b>ST</b>	<b>F8-7727</b>		H=86
Protective Cap/Bellow, shock absorber	316 i, 318 is, 320 i, 323 i, 328 i		<b>F8-7738</b>		H=200
Protective Cap/Bellow, shock absorber	318 is, 320 i, 325 i	06/1992 →;	<b>F8-7738</b>		H=200
Stabiliser Mounting	316 i, 318 is, 323 i, 328 i		<b>F8-7976</b>		D=17
Stabiliser Mounting	320 i, 325 i	M 50	<b>F8-7976</b>		D=17
Engine Mounting	316 i, 318 is, 320 i, 323 i, 325 i, 328 i, M3 3.0, M3 3.2		<b>F8-8174</b>		
Control Arm-/Trailing Arm Bush	316 i, 318 is, 320 i, 323 i, 325 i, 328 i		<b>G9-625</b>		H=34; d=18; D=60
Control Arm-/Trailing Arm Bush	316 i, 318 is, 320 i, 323 i, 325 i, 328 i		<b>G9-625S</b>		H=34; d=18; D=60
Bellow, steering	All Models	with clamps;	<b>LM-10011S</b>		d1=37; d2=51; L [mm]=185

### 3 Touring (E36)

01/1995 → 10/1999

Dust Cover Kit, shock absorber	318 i, 318 tds, 320 i, 323 i, 325 tds, 328 i		<b>AK-735004</b>		
Dust Cover Kit, shock absorber	All Models	<b>ST</b>	<b>AK-735126</b>		
Top Strut Mounting	All Models		<b>F8-5030</b>		H=35; d=10
Bellow, steering	318 i, 320 i, 323 i, 325 tds, 328 i		<b>F8-5171</b>		Total Br. Drum Height [mm]=185
Control Arm-/Trailing Arm Bush	All Models		<b>F8-5311</b>		H=49; d=12; D=61
Tie Bar Bush	318 i, 320 i, 325 tds, 328 i		<b>F8-5321</b>		H=57; d=12.2; D=45.4
Control Arm-/Trailing Arm Bush	318 i, 320 i, 325 tds, 328 i		<b>F8-5322</b>		H=56.5; d=12.1; D=35.6
Repair Set, axle beam	318 i, 320 i, 323 i, 325 tds, 328 i		<b>F8-5323</b>		d=12.5; D=60.5
Repair Set, axle beam	318 i, 320 i, 323 i, 325 tds, 328 i		<b>F8-5324</b>		d=15.5; D=62.5
Engine Mounting	320 i, 323 i, 328 i		<b>F8-5348</b>		
Engine Mounting	318 tds		<b>F8-5427</b>		
Engine Mounting	318 i, 318 tds		<b>F8-5428</b>		

<b>AK-735004</b>	<b>AK-735126</b>	<b>F8-5030</b>	<b>F8-5171</b>	<b>F8-5311</b>	<b>F8-5321</b>	<b>F8-5322</b>
Ref.Nr.:	Ref.Nr.: 33521136283	Ref.Nr.: 33504035929	Ref.Nr.: 32111137070	Ref.Nr.: 33321097009	Ref.Nr.: 33321136311	Ref.Nr.: 33321092248
<b>F8-5323</b>	<b>F8-5324</b>	<b>F8-5348</b>	<b>F8-5427</b>	<b>F8-5428</b>	<b>F8-5430</b>	<b>F8-6762</b>
Ref.Nr.: 33319059300	Ref.Nr.: 33319059301	Ref.Nr.: 11811082583	Ref.Nr.: 11811141889	Ref.Nr.: 11811137238	Ref.Nr.: 11811139883	Ref.Nr.: 2611127869
<b>F8-6777</b>	<b>F8-6778</b>	<b>F8-6783</b>	<b>F8-7425</b>	<b>F8-7684</b>	<b>F8-7700</b>	<b>F8-7727</b>
Ref.Nr.: 26121229089	Ref.Nr.: 26121229089-PA	Ref.Nr.: 26112226527	Ref.Nr.: 3133-1139436	Ref.Nr.: 1136283	Ref.Nr.: 33531138109	Ref.Nr.: 31331137932

**Article Description****Article Nr.****Fitting Position****3 Touring (E36)****01/1995 → 10/1999**

Engine Mounting	325 tds		<b>F8-5430</b>		
Top Strut Mounting	All Models		<b>F8-5506</b>		
Control Arm-/Trailing Arm Bush	All Models		<b>F8-5632</b>		H=57; d=12; D=45
Belt Pulley, crankshaft	320 i, 323 i, 328 i	09/1998 →	<b>F8-5662</b>		
Stabiliser Mounting	All Models		<b>F8-5689</b>		d=15; L=40; D=34
Rubber Buffer, suspension	318 i, 318 tds, 320 i, 323 i, 325 tds, 328 i		<b>F8-5690</b>		H=85
Control Arm-/Trailing Arm Bush	All Models		<b>F8-5746</b>		H=42, 66.5; d=12; D=35
Mounting, transfer gear	All Models		<b>F8-5839</b>		H=30; D=50
Control Arm-/Trailing Arm Bush	All Models		<b>F8-6102</b>		
Control Arm-/Trailing Arm Bush	All Models		<b>F8-6103</b>		
Mounting, automatic transmission	316 i, 318 i		<b>F8-6242</b>		H1=34; H2=69; D1=36; D2=50
Mounting, automatic transmission	325 tds		<b>F8-6491</b>		H=34; D=36, 50; Outer Thread [mm]=M8 x 1,25mm
Mounting, propshaft	316 i, 318 i, 318 tds		<b>F8-6777</b>		d=30
Mounting, propshaft	320 i, 323 i, 325 tds, 328 i		<b>F8-6777</b>		d=30
Mounting, propshaft	316 i, 318 i, 320 i		<b>F8-6778</b>		
Mounting, propshaft	318 tds		<b>F8-6778</b>		
Protective Cap/Bellow, shock absorber	All Models		<b>F8-7684</b>		H=194
Rubber Buffer, suspension	All Models	<b>SP</b>	<b>F8-7700</b>		H=90
Protective Cap/Bellow, shock absorber	All Models	<b>ST</b>	<b>F8-7727</b>		H=86
Protective Cap/Bellow, shock absorber	All Models		<b>F8-7738</b>		H=200
Stabiliser Mounting	316 i, 318 i, 318 tds, 323 i, 325 tds		<b>F8-7976</b>		D=17
Stabiliser Mounting	320 i	M 52	<b>F8-7976</b>		D=17
Engine Mounting	316 i, 318 i, 320 i, 323 i, 328 i		<b>F8-8174</b>		
Control Arm-/Trailing Arm Bush	318 i, 318 tds, 320 i, 323 i, 325 tds, 328 i		<b>G9-625</b>		H=34; d=18; D=60
Control Arm-/Trailing Arm Bush	318 i, 318 tds, 320 i, 323 i, 325 tds, 328 i		<b>G9-625S</b>		H=34; d=18; D=60
Bellow, steering	All Models	with clamps;	<b>LM-10011S</b>		d1=37; d2=51; L [mm]=185
<b>3 (E46)</b>					<b>02/1998 → 02/2005</b>
Dust Cover Kit, shock absorber	316 i, 318 d, 318 i, 320 d, 320 i, 323 i, 325 i, 325 xi, 328 i, 330 d, 330 i, 330 xd, 330 xi	<b>ST</b>	<b>AK-735126</b>		

<b>AK-735126</b>	<b>AK-735406</b>	<b>F8-5430</b>	<b>F8-5506</b>	<b>F8-5632</b>	<b>F8-5662</b>	<b>F8-5689</b>
Ref.Nr.: 33521136283	Ref.Nr.: 3133-1094750	Ref.Nr.: 11811139883	Ref.Nr.: 31336764947	Ref.Nr.: 33321138722	Ref.Nr.: 1 438 995	Ref.Nr.: 33551131155
<b>F8-5690</b>	<b>F8-5746</b>	<b>F8-5839</b>	<b>F8-6102</b>	<b>F8-6103</b>	<b>F8-6242</b>	<b>F8-6491</b>
Ref.Nr.: 31331125215	Ref.Nr.: 33321092247	Ref.Nr.: 33171134872	Ref.Nr.: 31121136531	Ref.Nr.: 31121136532	Ref.Nr.: 23711133487	Ref.Nr.: 23 71 1 131 664
<b>F8-6777</b>	<b>F8-6778</b>	<b>F8-7684</b>	<b>F8-7700</b>	<b>F8-7727</b>	<b>F8-7738</b>	<b>F8-7976</b>
Ref.Nr.: 26121229089	Ref.Nr.: 26121229089-PA	Ref.Nr.: 1136283	Ref.Nr.: 33531138109	Ref.Nr.: 31331137932	Ref.Nr.: 31321125878	Ref.Nr.: 33551138104

Article Description



Article Nr.

Fitting Position



3 (E46)			02/1998 → 02/2005		
Dust Cover Kit, shock absorber	316 i, 318 d, 318 i, 320 d	<b>ST</b>	<b>AK-735406</b>		H=136, 86
Dust Cover Kit, shock absorber	316 i, 320 i, 325 i	09/2001 →; <b>ST</b>	<b>AK-735406</b>		H=136, 86
Dust Cover Kit, shock absorber	330 d, 330 i	04/2001 →; <b>ST</b>	<b>AK-735406</b>		H=136, 86
Dust Cover Kit, shock absorber	316 i, 318 d, 320 d	<b>ST</b>	<b>AK-735407</b>		H=136, 90
Dust Cover Kit, shock absorber	316 i, 320 i, 325 i	09/2001 →; <b>ST</b>	<b>AK-735407</b>		H=136, 90
Dust Cover Kit, shock absorber	318 i		<b>AK-735407</b>		H=136, 90
Dust Cover Kit, shock absorber	330 d, 330 i	04/2001 →	<b>AK-735407</b>		H=136, 90
Dust Cover Kit, shock absorber	320 d, 320 i	<b>SP</b>	<b>AK-735408</b>	⊕ ⊕	
Dust Cover Kit, shock absorber	325 i	09/2001 →; <b>SP</b>	<b>AK-735408</b>	⊕ ⊕	
Dust Cover Kit, shock absorber	330 d	<b>ST</b>	<b>AK-735408</b>	⊕ ⊕	
Dust Cover Kit, shock absorber	330 d, 330 i	04/2001 →; <b>ST</b>	<b>AK-735408</b>	⊕ ⊕	
Alternator Freewheel Clutch	316 i, 318 i		<b>F5-1051</b>		
Alternator Freewheel Clutch	316 i, 318 i		<b>F5-1053</b>		
Top Strut Mounting	316 i, 318 d, 318 i, 320 d, 320 i, 323 i, 325 i, 325 xi, 328 i, 330 d, 330 i, 330 xd, 330 xi		<b>F8-5030</b>	⊕ ⊕	H=35; d=10
Holder, control arm mounting	316 i, 318 d, 318 i, 320 d, 320 i, 323 i, 325 i, 328 i, 330 d, 330 i	Aluminium	<b>F8-5280</b>	⊕ ↓	D=66
Holder, control arm mounting	316 i, 318 d, 318 i, 320 d, 320 i, 323 i, 325 i, 328 i, 330 d, 330 i	Aluminium	<b>F8-5281</b>	⊕ ↓	D=66
Control Arm-/Trailing Arm Bush	316 i, 318 d, 318 i, 320 d, 320 i, 323 i, 325 i, 325 xi, 328 i, 330 d, 330 i, 330 xd, 330 xi		<b>F8-5311</b>	⊕ ⊕	H=49; d=12; D=61
Mounting, axle beam	316 i, 318 d, 318 i, 320 d, 320 i, 323 i, 325 i, 325 xi, 328 i, 330 d, 330 i, 330 xd, 330 xi		<b>F8-5318</b>	⊕	d=12,5; D=70
Mounting, axle beam	316 i, 318 d, 318 i, 320 d, 320 i, 323 i, 325 i, 325 xi, 328 i, 330 d, 330 i, 330 xd, 330 xi		<b>F8-5319</b>	⊕	H=66; d=12; D=70.3
Mounting, axle beam	316 i, 318 d, 318 i, 320 d, 320 i, 323 i, 325 i, 325 xi, 328 i, 330 d, 330 i, 330 xd, 330 xi		<b>F8-5320</b>	⊕ ⊕	H=63; d=20.5; D=72
Tie Bar Bush	316 i, 318 i, 320 d, 320 i, 323 i, 328 i, 330 d		<b>F8-5321</b>	⊕ ⊕	H=57; d=12.2; D=45.4
Control Arm-/Trailing Arm Bush	316 i, 318 i, 320 d, 320 i, 323 i, 328 i, 330 d		<b>F8-5322</b>	⊕ ⊕ ↓	H=56.5; d=12.1; D=35.6
Engine Mounting	320 i, 323 i, 325 i, 328 i, 330 i		<b>F8-5348</b>	⊕ ⊕	
Engine Mounting	316 i, 318 i	N42, N46	<b>F8-5422</b>	⊕	
Engine Mounting	318 d, 318 i		<b>F8-5422</b>	⊕ ⊕	
Engine Mounting	318 d, 318 i		<b>F8-5422</b>	⊕	
Engine Mounting	320 d		<b>F8-5422</b>	⊕	
Engine Mounting	320 d		<b>F8-5422</b>	⊕	
Engine Mounting	316 i, 318 i	N42, N46	<b>F8-5423</b>	⊕ ⊕	
Engine Mounting	318 d, 320 d		<b>F8-5423</b>	⊕ ⊕	

<b>AK-735406</b>	<b>AK-735407</b>	<b>AK-735408</b>	<b>F5-1051</b>	<b>F5-1053</b>	<b>F8-5030</b>	<b>F8-5280</b>
Ref.Nr.: 3133-1094750	Ref.Nr.: 3133-1094749	Ref.Nr.: 3130-6757046	Ref.Nr.: 12317516099	Ref.Nr.: 12314466273	Ref.Nr.: 33504035929	Ref.Nr.: 31124004359
<b>F8-5281</b>	<b>F8-5311</b>	<b>F8-5318</b>	<b>F8-5319</b>	<b>F8-5320</b>	<b>F8-5321</b>	<b>F8-5322</b>
Ref.Nr.: 31126754900	Ref.Nr.: 33321097009	Ref.Nr.: 33311092515	Ref.Nr.: 33311092516	Ref.Nr.: 33311092517	Ref.Nr.: 33321136311	Ref.Nr.: 33321092248
<b>F8-5348</b>	<b>F8-5422</b>	<b>F8-5423</b>	<b>F8-5433</b>			
Ref.Nr.: 11811082583	Ref.Nr.: 22 11 6 779 972	Ref.Nr.: 22 11 6 779 971	Ref.Nr.: 31331094616			



**Article Description****Article Nr.****Fitting Position****3 (E46)****02/1998 → 02/2005**

Top Strut Mounting	316 i, 318 d, 318 i, 320 d, 320 i, 323 i, 325 i, 325 xi, 328 i, 330 d, 330 i, 330 xd, 330 xi		<b>F8-5433</b>		
Control Arm-/Trailing Arm Bush	316 i, 318 d, 318 i, 320 d, 320 i, 323 i, 325 i, 325 xi, 328 i, 330 d, 330 i, 330 xd, 330 xi		<b>F8-5632</b>		H=57; d=12; D=45
Belt Pulley, crankshaft	320 i, 325 i, 325 xi, 330 i, 330 xi	09/2002 →	<b>F8-5661</b>		
Belt Pulley, crankshaft	320 i		<b>F8-5662</b>		
Belt Pulley, crankshaft	323 i, 328 i	11/1998 →	<b>F8-5662</b>		
Belt Pulley, crankshaft	325 i, 325 xi, 330 i, 330 xi	07/2001 →	<b>F8-5662</b>		
Control Arm-/Trailing Arm Bush	316 i, 318 d, 318 i, 320 d, 320 i, 323 i, 325 i, 325 xi, 328 i, 330 d, 330 i, 330 xd, 330 xi		<b>F8-5746</b>		H=42, 66.5; d=12; D=35
Mounting, axle beam	316 i, 318 d, 318 i, 320 d, 320 i, 323 i, 325 i, 325 xi, 328 i, 330 d, 330 i, 330 xd, 330 xi		<b>F8-5886</b>		H1=47; H2=40; D=47
Rubber Buffer, suspension	316 i, 318 d, 318 i, 320 d, 320 i, 323 i, 325 i, 325 xi, 328 i, 330 d, 330 i, 330 xd, 330 xi	<b>ST</b> , <b>MT</b> , <b>SP</b>	<b>F8-5963</b>		H=105
Rubber Buffer, suspension	316 i, 318 d, 318 i, 320 d, 320 i, 323 i, 325 i, 328 i, 330 d, 330 i	<b>SP</b>	<b>F8-6088</b>		H=75
Engine Mounting	325 xi, 330 xi		<b>F8-6215</b>		
Engine Mounting	330 d		<b>F8-6216</b>		
Control Arm-/Trailing Arm Bush	316 i, 318 i, 320 d, 320 i, 323 i, 328 i, 330 d, 330 i		<b>F8-6243</b>		H=55; d=20; D=60.4
Mounting, automatic transmission	330 d		<b>F8-6491</b>		H=34; D=36, 50; Outer Thread [mm]=M8 x 1,25mm
Mounting, automatic transmission	330 d	M57 306 D1	<b>F8-6491</b>		H=34; D=36, 50; Outer Thread [mm]=M8 x 1,25mm
Rubber Buffer, suspension	316 i, 318 i, 320 d, 320 i, 323 i, 325 i, 328 i, 330 d, 330 i		<b>F8-6542</b>		H=86
Rubber Buffer, suspension	316 i, 318 d, 320 d	<b>ST</b>	<b>F8-6543</b>		H=90
Rubber Buffer, suspension	316 i, 320 i, 325 i	09/2001 →; <b>ST</b>	<b>F8-6543</b>		H=90
Rubber Buffer, suspension	318 i		<b>F8-6543</b>		H=90
Rubber Buffer, suspension	330 d, 330 i	04/2001 →	<b>F8-6543</b>		H=90
Protective Cap/Bellow, shock absorber	316 i, 318 d, 318 i, 320 d, 320 i, 323 i, 325 i, 325 xi, 328 i, 330 d, 330 i, 330 xd, 330 xi	Universal	<b>F8-6545</b>		H=140
Spring Cap	316 i, 318 d, 318 i, 320 d, 320 i, 323 i, 325 i, 325 xi, 328 i, 330 d, 330 i, 330 xd, 330 xi		<b>F8-6566</b>		
Joint, propshaft	325 xi, 330 xd, 330 xi		<b>F8-6763</b>		d=50; D=128; Thick./Strength 1 [mm]=39
Mounting, propshaft	316 i, 318 i		<b>F8-6777</b>		d=30
Engine Mounting	325 xi, 330 xi		<b>F8-6942</b>		
Engine Mounting	320 d		<b>F8-6943</b>		
Protective Cap/Bellow, shock absorber	316 i, 318 d, 318 i, 320 d, 320 i, 323 i, 325 i, 325 xi, 328 i, 330 d, 330 i, 330 xd, 330 xi	Available as universal article: F8-6545	<b>F8-7336</b>		H=136

<b>F8-5433</b>	<b>F8-5632</b>	<b>F8-5661</b>	<b>F8-5662</b>	<b>F8-5746</b>	<b>F8-5886</b>	<b>F8-5963</b>
Ref.Nr.: 31331094616	Ref.Nr.: 33321138722	Ref.Nr.: 11237513862	Ref.Nr.: 1 438 995	Ref.Nr.: 33321092247	Ref.Nr.: 33171093175	Ref.Nr.: 33531136395
<b>F8-6088</b>	<b>F8-6215</b>	<b>F8-6216</b>	<b>F8-6243</b>	<b>F8-6491</b>	<b>F8-6542</b>	<b>F8-6543</b>
Ref.Nr.: 6778544	Ref.Nr.: 11817837985	Ref.Nr.: 22116750109	Ref.Nr.: 31121096982	Ref.Nr.: 23 71 1 131 664	Ref.Nr.: 1094750	Ref.Nr.: 3133-6750892
<b>F8-6545</b>	<b>F8-6566</b>	<b>F8-6763</b>	<b>F8-6777</b>	<b>F8-6942</b>	<b>F8-6943</b>	<b>F8-7336</b>
Ref.Nr.: 0146239	Ref.Nr.: 31326769667	Ref.Nr.: 26111227717	Ref.Nr.: 26121229089	Ref.Nr.: 22116750862	Ref.Nr.: 22116756018	Ref.Nr.: 31331094749

### Article Description



Article Nr.

Fitting Position



<b>3 (E46)</b>		<b>02/1998 → 02/2005</b>			
Belt Pulley, crankshaft	330 d, 330 xd	Number of Ribs: 3, 5; Parameter: 6PK + 4PK	<b>F8-7641</b>		
Protective Cap/Bellow, shock absorber	316 i, 318 d, 318 i, 320 d, 320 i, 323 i, 325 i, 325 xi, 328 i, 330 d, 330 i, 330 xd, 330 xi		<b>F8-7684</b>		H=194
Rubber Buffer, suspension	316 i, 318 d, 318 i, 320 d, 320 i, 323 i, 325 i, 328 i, 330 d, 330 i	<b>SP</b>	<b>F8-7700</b>		H=90
Stabiliser Mounting	316 i, 318 d, 318 i, 320 d, 320 i, 323 i, 325 i		<b>F8-7918</b>		d=23
Stabiliser Mounting	316 i, 318 d, 318 i, 320 d, 320 i		<b>F8-7933</b>		d=24,6
Stabiliser Mounting	316 i	N46	<b>F8-7976</b>		D=17
Stabiliser Mounting	316 i, 318 d, 318 i, 320 d, 320 i, 323 i, 328 i, 330 d		<b>F8-7976</b>		D=17
Stabiliser Mounting	316 i, 318 i	N42	<b>F8-7976</b>		D=17
Stabiliser Mounting	320 i, 325 i, 330 i	M54	<b>F8-7976</b>		D=17
Engine Mounting	325 xi, 330 xd, 330 xi		<b>F8-8163</b>		
Engine Mounting	320 i, 323 i, 325 i, 328 i, 330 i		<b>F8-8174</b>		
Mounting, propshaft	316 i, 318 i		<b>F8-8226</b>		
Mounting, propshaft	325 xi, 330 xd, 330 xi		<b>F8-8226</b>		
Mounting, axle beam	316 i, 318 d, 318 i, 320 d, 320 i, 323 i, 325 i, 325 xi, 328 i, 330 d, 330 i, 330 xd, 330 xi		<b>F8-8230</b>		
Suspension Kit	316 i, 318 d, 318 i, 320 d, 320 i, 323 i, 325 i, 328 i, 330 d, 330 i	Aluminium; with fastening material	<b>G8-544</b>		D=66
Bellow, steering	316 i, 318 d, 318 i, 320 d, 320 i, 325 i, 330 d, 330 i	with clamps;	<b>LM-10011S</b>		d1=37; d2=51; L [mm]=185
Bellow, steering	318 i, 320 d, 320 i, 323 i, 328 i	09/1998 →; with clamps;	<b>LM-10011S</b>		d1=37; d2=51; L [mm]=185
Bellow, steering	316 i, 318 d, 318 i, 320 d, 320 i, 323 i, 325 i, 328 i, 330 d, 330 i	with clamps	<b>LM-10078S</b>		d1=15; d2=55; L [mm]=186
<b>3 Convertible (E46)</b>		<b>04/2000 → 12/2007</b>			
Dust Cover Kit, shock absorber	318 Ci, 320 Ci, 323 Ci, 325 Ci, 330 Ci	<b>ST</b>	<b>AK-735126</b>		
Alternator Freewheel Clutch	318 Ci		<b>F5-1051</b>		
Alternator Freewheel Clutch	318 Ci		<b>F5-1053</b>		
Anti-Friction Bearing	M3 3.2		<b>F8-3063</b>		
Holder, control arm mounting	318 Ci, 320 Cd, 320 Ci, 323 Ci, 325 Ci, 330 Cd, 330 Ci	Aluminium	<b>F8-5280</b>		D=66
Holder, control arm mounting	318 Ci, 320 Cd, 320 Ci, 323 Ci, 325 Ci, 330 Cd, 330 Ci	Aluminium	<b>F8-5281</b>		D=66
Control Arm-/Trailing Arm Bush	318 Ci, 320 Cd, 320 Ci, 323 Ci, 325 Ci, 330 Cd, 330 Ci		<b>F8-5311</b>		H=49; d=12; D=61
Mounting, axle beam	318 Ci, 320 Cd, 320 Ci, 323 Ci, 325 Ci, 330 Cd, 330 Ci		<b>F8-5318</b>		d=12,5; D=70
Mounting, axle beam	318 Ci, 320 Cd, 320 Ci, 323 Ci, 325 Ci, 330 Cd, 330 Ci		<b>F8-5319</b>		H=66; d=12; D=70.3
Mounting, axle beam	318 Ci, 320 Cd, 320 Ci, 323 Ci, 325 Ci, 330 Cd, 330 Ci		<b>F8-5320</b>		H=63; d=20.5; D=72
Engine Mounting	320 Ci, 323 Ci, 325 Ci, 330 Ci		<b>F8-5348</b>		
Engine Mounting	318 Ci	N42, N46	<b>F8-5422</b>		



**Article Description****Article Nr.****Fitting Position****3 Convertible (E46)****04/2000 → 12/2007**

Engine Mounting	318 Ci	N42, N46	<b>F8-5423</b>		
Engine Mounting	320 Cd		<b>F8-5423</b>		
Top Strut Mounting	318 Ci, 320 Cd, 320 Ci, 323 Ci, 325 Ci, 330 Cd, 330 Ci, M3 3.2		<b>F8-5433</b>		
Control Arm-/Trailing Arm Bush	318 Ci, 320 Cd, 320 Ci, 323 Ci, 325 Ci, 330 Cd, 330 Ci, M3 3.2		<b>F8-5632</b>		H=57; d=12; D=45
Belt Pulley, crankshaft	320 Ci, 325 Ci, 330 Ci	09/2002 →	<b>F8-5661</b>		
Belt Pulley, crankshaft	320 Ci, 323 Ci, 325 Ci		<b>F8-5662</b>		
Belt Pulley, crankshaft	330 Ci	09/2001 →	<b>F8-5662</b>		
Control Arm-/Trailing Arm Bush	318 Ci, 320 Cd, 320 Ci, 323 Ci, 325 Ci, 330 Cd, 330 Ci, M3 3.2		<b>F8-5746</b>		H=42, 66.5; d=12; D=35
Mounting, axle beam	318 Ci, 320 Cd, 320 Ci, 323 Ci, 325 Ci, 330 Cd, 330 Ci, M3 3.2		<b>F8-5886</b>		H1=47; H2=40; D=47
Rubber Buffer, suspension	318 Ci, 320 Ci, 323 Ci, 325 Ci, 330 Ci	<b>ST, MT, SP</b>	<b>F8-5963</b>		H=105
Rubber Buffer, suspension	318 Ci, 320 Cd, 320 Ci, 323 Ci, 325 Ci, 330 Ci	<b>SP</b>	<b>F8-6088</b>		H=75
Engine Mounting	M3 3.2		<b>F8-6215</b>		
Engine Mounting	330 Cd		<b>F8-6216</b>		
Mounting, automatic transmission	330 Cd		<b>F8-6491</b>		H=34; D=36, 50; Outer Thread [mm]=M8 x 1,25mm
Rubber Buffer, suspension	318 Ci, 320 Ci, 323 Ci, 325 Ci, 330 Ci		<b>F8-6542</b>		H=86
Protective Cap/Bellow, shock absorber	318 Ci, 320 Cd, 320 Ci, 323 Ci, 325 Ci, 330 Cd, 330 Ci, M3 3.2	Universal	<b>F8-6545</b>		H=140
Spring Cap	318 Ci, 320 Cd, 320 Ci, 323 Ci, 325 Ci, 330 Cd, 330 Ci, M3 3.2		<b>F8-6566</b>		
Joint, propshaft	M3 3.2		<b>F8-6783</b>		
Engine Mounting	320 Cd		<b>F8-6943</b>		
Protective Cap/Bellow, shock absorber	318 Ci, 320 Cd, 320 Ci, 323 Ci, 325 Ci, 330 Cd, 330 Ci, M3 3.2	Available as universal article: F8-6545	<b>F8-7336</b>		H=136
Belt Pulley, crankshaft	330 Cd	Number of Ribs: 3, 5; Parameter: 6PK + 4PK	<b>F8-7641</b>		
Protective Cap/Bellow, shock absorber	318 Ci, 320 Cd, 320 Ci, 323 Ci, 325 Ci, 330 Cd, 330 Ci, M3 3.2		<b>F8-7684</b>		H=194
Rubber Buffer, suspension	318 Ci, 320 Cd, 320 Ci, 323 Ci, 325 Ci, 330 Cd, 330 Ci	<b>SP</b>	<b>F8-7700</b>		H=90
Stabiliser Mounting	318 Ci	N42	<b>F8-7976</b>		D=17
Stabiliser Mounting	318 Ci	N46	<b>F8-7976</b>		D=17
Stabiliser Mounting	320 Cd, 320 Ci, 323 Ci, 330 Cd, M3 3.2		<b>F8-7976</b>		D=17
Stabiliser Mounting	325 Ci, 330 Ci	M54	<b>F8-7976</b>		D=17
Engine Mounting	320 Ci, 323 Ci, 325 Ci, 330 Ci		<b>F8-8174</b>		
Mounting, propshaft	318 Ci		<b>F8-8226</b>		

<b>F8-5423</b>	<b>F8-5433</b>	<b>F8-5632</b>	<b>F8-5661</b>	<b>F8-5662</b>	<b>F8-5746</b>	<b>F8-5886</b>
Ref.Nr.: 22 11 6 779 971	Ref.Nr.: 31331094616	Ref.Nr.: 33321138722	Ref.Nr.: 11237513862	Ref.Nr.: 1 438 995	Ref.Nr.: 33321092247	Ref.Nr.: 33171093175
<b>F8-5963</b>	<b>F8-6088</b>	<b>F8-6215</b>	<b>F8-6216</b>	<b>F8-6491</b>	<b>F8-6542</b>	<b>F8-6545</b>
Ref.Nr.: 33531136395	Ref.Nr.: 6778544	Ref.Nr.: 11817837985	Ref.Nr.: 22116750109	Ref.Nr.: 23 71 1 131 664	Ref.Nr.: 1094750	Ref.Nr.: 0146239
<b>F8-6566</b>	<b>F8-6783</b>	<b>F8-6943</b>	<b>F8-7336</b>	<b>F8-7641</b>	<b>F8-7684</b>	<b>F8-7700</b>
Ref.Nr.: 31326769667	Ref.Nr.: 26112226527	Ref.Nr.: 22116756018	Ref.Nr.: 31331094749	Ref.Nr.: 11237793593	Ref.Nr.: 1136283	Ref.Nr.: 33531138109

Article Description



Article Nr.

Fitting Position



### 3 Convertible (E46)

04/2000 → 12/2007

Mounting, axle beam	318 Ci, 320 Cd, 320 Ci, 323 Ci, 325 Ci, 330 Cd, 330 Ci		F8-8230		
Suspension Kit	318 Ci, 320 Cd, 320 Ci, 323 Ci, 325 Ci, 330 Cd, 330 Ci	Aluminium; with fastening material	G8-544		D=66
Bellow, steering	318 Ci, 320 Cd, 320 Ci, 323 Ci, 325 Ci, 330 Cd, 330 Ci, M3 3.2	with clamps;	LM-10011S		d1=37; d2=51; L [mm]=185
Bellow, steering	318 Ci, 320 Cd, 320 Ci, 323 Ci, 325 Ci, 330 Cd, 330 Ci, M3 3.2	with clamps	LM-10078S		d1=15; d2=55; L [mm]=186

### 3 Compact (E46)

06/2001 → 02/2005

Dust Cover Kit, shock absorber	320 td, 325 ti	ST	AK-735126		
Dust Cover Kit, shock absorber	316 ti, 318 ti	ST	AK-735406		H=136, 86
Dust Cover Kit, shock absorber	316 ti, 318 ti	ST	AK-735407		H=136, 90
Dust Cover Kit, shock absorber	320 td	03/2003 →; SP	AK-735408		
Dust Cover Kit, shock absorber	325 ti	ST	AK-735408		
Alternator Freewheel Clutch	316 ti, 318 ti		F5-1051		
Alternator Freewheel Clutch	316 ti, 318 ti		F5-1053		
Top Strut Mounting	316 ti, 318 td, 318 ti, 320 td, 325 ti		F8-5030		H=35; d=10
Holder, control arm mounting	316 ti, 318 td, 318 ti, 320 td, 325 ti	Aluminium	F8-5280		D=66
Holder, control arm mounting	316 ti, 318 td, 318 ti, 320 td, 325 ti	Aluminium	F8-5281		D=66
Control Arm-/Trailing Arm Bush	All Models		F8-5311		H=49; d=12; D=61
Mounting, axle beam	All Models		F8-5318		d=12.5; D=70
Mounting, axle beam	All Models		F8-5319		H=66; d=12; D=70.3
Mounting, axle beam	316 ti, 318 td, 318 ti, 320 td, 325 ti		F8-5320		H=63; d=20.5; D=72
Engine Mounting	325 ti		F8-5348		
Engine Mounting	316 ti, 318 ti	N42, N46	F8-5422		
Engine Mounting	318 td		F8-5422		
Engine Mounting	320 td		F8-5422		
Engine Mounting	316 ti, 318 ti	N42, N46	F8-5423		
Engine Mounting	318 td, 320 td		F8-5423		
Top Strut Mounting	316 ti, 318 td, 318 ti, 320 td, 325 ti		F8-5433		
Control Arm-/Trailing Arm Bush	316 ti, 318 td, 318 ti, 320 td, 325 ti		F8-5632		H=57; d=12; D=45
Belt Pulley, crankshaft	325 ti	09/2002 →	F8-5661		
Belt Pulley, crankshaft	325 ti		F8-5662		
Control Arm-/Trailing Arm Bush	316 ti, 318 td, 318 ti, 320 td, 325 ti		F8-5746		H=42, 66.5; d=12; D=35
Mounting, axle beam	316 ti, 318 td, 318 ti, 320 td, 325 ti		F8-5886		H1=47; H2=40; D=47
Rubber Buffer, suspension	316 ti, 318 ti	SP	F8-6088		H=75

<b>AK-735126</b>	<b>AK-735406</b>	<b>AK-735407</b>	<b>AK-735408</b>	<b>F5-1051</b>	<b>F5-1053</b>	<b>F8-5030</b>
Ref.Nr.: 33521136283	Ref.Nr.: 3133-1094750	Ref.Nr.: 3133-1094749	Ref.Nr.: 3130-6757046	Ref.Nr.: 12317516099	Ref.Nr.: 12314466273	Ref.Nr.: 33504035929
<b>F8-5280</b>	<b>F8-5281</b>	<b>F8-5311</b>	<b>F8-5318</b>	<b>F8-5319</b>	<b>F8-5320</b>	<b>F8-5348</b>
Ref.Nr.: 31124004359	Ref.Nr.: 31126754900	Ref.Nr.: 33321097009	Ref.Nr.: 33311092515	Ref.Nr.: 33311092516	Ref.Nr.: 33311092517	Ref.Nr.: 11811082583
<b>F8-5422</b>	<b>F8-5423</b>	<b>F8-5433</b>	<b>F8-5632</b>	<b>F8-5661</b>	<b>F8-5662</b>	<b>F8-5746</b>
Ref.Nr.: 22 11 6 779 972	Ref.Nr.: 22 11 6 779 971	Ref.Nr.: 31331094616	Ref.Nr.: 33321138722	Ref.Nr.: 11237513862	Ref.Nr.: 1 438 995	Ref.Nr.: 33321092247

**Article Description****Article Nr.****Fitting Position**

<b>3 Compact (E46)</b>				<b>06/2001 → 02/2005</b>	
Rubber Buffer, suspension	316 ti, 318 ti	<b>ST</b>	<b>F8-6543</b>		H=90
Rubber Buffer, suspension	320 td, 325 ti		<b>F8-6544</b>		
Protective Cap/Bellow, shock absorber	All Models	Universal	<b>F8-6545</b>		H=140
Spring Cap	All Models		<b>F8-6566</b>		
Engine Mounting	320 td		<b>F8-6943</b>		
Protective Cap/Bellow, shock absorber	All Models	Available as universal article: F8-6545	<b>F8-7336</b>		H=136
Protective Cap/Bellow, shock absorber	All Models		<b>F8-7684</b>		H=194
Rubber Buffer, suspension	316 ti, 318 td, 318 ti, 320 td, 325 ti	<b>SP</b>	<b>F8-7700</b>		H=90
Stabiliser Mounting	316 ti, 318 td, 318 ti		<b>F8-7933</b>		d=24,6
Engine Mounting	325 ti		<b>F8-8174</b>		
Mounting, propshaft	316 ti, 318 ti		<b>F8-8226</b>		
Mounting, axle beam	All Models		<b>F8-8230</b>		
Suspension Kit	All Models	Aluminium; with fastening material	<b>G8-544</b>		D=66
Bellow, steering	All Models	with clamps;	<b>LM-10011S</b>		d1=37; d2=51; L [mm]=185
Bellow, steering	All Models	with clamps	<b>LM-10078S</b>		d1=15; d2=55; L [mm]=186
<b>3 Coupe (E46)</b>				<b>04/1999 → 07/2006</b>	
Dust Cover Kit, shock absorber	316 Ci, 318 Ci, 320 Cd, 320 Ci, 323 Ci, 325 Ci, 328 Ci, 330 Cd, 330 Ci	<b>ST</b>	<b>AK-735126</b>		
Dust Cover Kit, shock absorber	318 Ci	03/2003 →; <b>SP</b>	<b>AK-735408</b>		
Dust Cover Kit, shock absorber	318 Ci	<b>SP</b>	<b>AK-735408</b>		
Dust Cover Kit, shock absorber	320 Cd, 320 Ci, 330 Cd	<b>ST</b>	<b>AK-735408</b>		
Dust Cover Kit, shock absorber	320 Ci, 325 Ci	09/2001 →; <b>ST</b>	<b>AK-735408</b>		
Dust Cover Kit, shock absorber	330 Ci	04/2001 →; <b>ST</b>	<b>AK-735408</b>		
Alternator Freewheel Clutch	316 Ci, 318 Ci		<b>F5-1051</b>		
Alternator Freewheel Clutch	316 Ci, 318 Ci		<b>F5-1053</b>		
Anti-Friction Bearing	M3 3.2, M3 CSL		<b>F8-3063</b>		
Holder, control arm mounting	316 Ci, 318 Ci, 320 Cd, 320 Ci, 323 Ci, 325 Ci, 328 Ci, 330 Cd	Aluminium	<b>F8-5280</b>		D=66
Holder, control arm mounting	316 Ci, 318 Ci, 320 Cd, 320 Ci, 323 Ci, 325 Ci, 328 Ci, 330 Cd	Aluminium	<b>F8-5281</b>		D=66
Control Arm-/Trailing Arm Bush	316 Ci, 318 Ci, 320 Cd, 320 Ci, 323 Ci, 325 Ci, 328 Ci, 330 Cd, 330 Ci, 330 xi		<b>F8-5311</b>		H=49; d=12; D=61
Mounting, axle beam	316 Ci, 318 Ci, 320 Cd, 320 Ci, 323 Ci, 325 Ci, 328 Ci, 330 Cd, 330 Ci, 330 xi		<b>F8-5318</b>		d=12,5; D=70
Mounting, axle beam	316 Ci, 318 Ci, 320 Cd, 320 Ci, 323 Ci, 325 Ci, 328 Ci, 330 Cd, 330 Ci, 330 xi		<b>F8-5319</b>		H=66; d=12; D=70.3

<b>AK-735126</b>	<b>AK-735408</b>	<b>F5-1051</b>	<b>F5-1053</b>	<b>F8-3063</b>	<b>F8-5280</b>	<b>F8-5281</b>
Ref.Nr.: 33521136283	Ref.Nr.: 3130-6757046	Ref.Nr.: 12317516099	Ref.Nr.: 12314466273	Ref.Nr.: 1090612	Ref.Nr.: 31124004359	Ref.Nr.: 31126754900
<b>F8-5311</b>	<b>F8-5318</b>	<b>F8-5319</b>	<b>F8-5320</b>	<b>F8-6543</b>	<b>F8-6544</b>	<b>F8-6545</b>
Ref.Nr.: 33321097009	Ref.Nr.: 33311092515	Ref.Nr.: 33311092516	Ref.Nr.: 33311092517	Ref.Nr.: 3133-6750892	Ref.Nr.: 3130-6757046	Ref.Nr.: 0146239
<b>F8-6566</b>	<b>F8-6943</b>	<b>F8-7336</b>	<b>F8-7684</b>	<b>F8-7700</b>	<b>F8-7933</b>	<b>F8-8174</b>
Ref.Nr.: 31326769667	Ref.Nr.: 22116756018	Ref.Nr.: 31331094749	Ref.Nr.: 1136283	Ref.Nr.: 33531138109	Ref.Nr.: 31351095271	Ref.Nr.: 23711137817

Article Description



Article Nr.

Fitting Position



### 3 Coupe (E46)

04/1999 → 07/2006

Mounting, axle beam	316 Ci, 318 Ci, 320 Cd, 320 Ci, 323 Ci, 325 Ci, 328 Ci, 330 Cd, 330 Ci		F8-5320		H=63; d=20.5; D=72
Tie Bar Bush	318 Ci, 320 Ci, 323 Ci, 328 Ci		F8-5321		H=57; d=12.2; D=45.4
Control Arm-/Trailing Arm Bush	318 Ci, 320 Ci, 323 Ci, 328 Ci		F8-5322		H=56.5; d=12.1; D=35.6
Engine Mounting	320 Ci, 323 Ci, 325 Ci, 328 Ci, 330 Ci		F8-5348		
Engine Mounting	316 Ci, 318 Ci		F8-5422		
Engine Mounting	318 Ci	N42, N46	F8-5422		
Engine Mounting	320 Cd		F8-5422		
Engine Mounting	316 Ci, 320 Cd		F8-5423		
Engine Mounting	318 Ci	N42, N46	F8-5423		
Top Strut Mounting	316 Ci, 318 Ci, 320 Cd, 320 Ci, 323 Ci, 325 Ci, 328 Ci, 330 Cd, 330 Ci, M3 3.2, M3 CSL		F8-5433		
Control Arm-/Trailing Arm Bush	316 Ci, 318 Ci, 320 Cd, 320 Ci, 323 Ci, 325 Ci, 328 Ci, 330 Cd, 330 Ci, M3 3.2		F8-5632		H=57; d=12; D=45
Control Arm-/Trailing Arm Bush	M3 CSL	S54N	F8-5632		H=57; d=12; D=45
Belt Pulley, crankshaft	320 Ci, 325 Ci, 330 Ci	09/2002 →	F8-5661		
Belt Pulley, crankshaft	320 Ci, 323 Ci, 325 Ci, 328 Ci, 330 Ci, 330 xi		F8-5662		
Control Arm-/Trailing Arm Bush	316 Ci, 318 Ci, 320 Cd, 320 Ci, 323 Ci, 325 Ci, 328 Ci, 330 Cd, 330 Ci, M3 3.2, M3 CSL		F8-5746		H=42, 66.5; d=12; D=35
Mounting, axle beam	All Models		F8-5886		H1=47; H2=40; D=47
Rubber Buffer, suspension	316 Ci, 318 Ci, 320 Ci, 323 Ci, 325 Ci, 328 Ci		F8-5963		H=105
Rubber Buffer, suspension	316 Ci, 318 Ci, 320 Cd, 320 Ci, 323 Ci, 325 Ci, 328 Ci		F8-6088		H=75
Engine Mounting	M3 3.2, M3 CSL		F8-6215		
Engine Mounting	330 Cd		F8-6216		
Control Arm-/Trailing Arm Bush	318 Ci, 320 Ci, 323 Ci, 328 Ci		F8-6243		H=55; d=20; D=60.4
Mounting, automatic transmission	330 Cd		F8-6491		H=34; D=36, 50; Outer Thread [mm]=M8 x 1,25mm
Rubber Buffer, suspension	316 Ci, 318 Ci, 320 Ci, 323 Ci, 325 Ci, 328 Ci		F8-6542		H=86
Protective Cap/Bellow, shock absorber	All Models	Universal	F8-6545		H=140
Spring Cap	All Models		F8-6566		
Mounting, propshaft	316 Ci, 318 Ci		F8-6777		d=30
Joint, propshaft	M3 3.2, M3 CSL		F8-6783		
Engine Mounting	320 Cd		F8-6943		
Protective Cap/Bellow, shock absorber	All Models	Available as universal article: F8-6545	F8-7336		H=136

<b>F8-5320</b>	<b>F8-5321</b>	<b>F8-5322</b>	<b>F8-5348</b>	<b>F8-5422</b>	<b>F8-5423</b>	<b>F8-5433</b>
Ref.Nr.: 33311092517	Ref.Nr.: 33321136311	Ref.Nr.: 33321092248	Ref.Nr.: 11811082583	Ref.Nr.: 22 11 6 779 972	Ref.Nr.: 22 11 6 779 971	Ref.Nr.: 31331094616
<b>F8-5632</b>	<b>F8-5661</b>	<b>F8-5662</b>	<b>F8-5746</b>	<b>F8-5886</b>	<b>F8-5963</b>	<b>F8-6088</b>
Ref.Nr.: 33321138722	Ref.Nr.: 11237513862	Ref.Nr.: 1 438 995	Ref.Nr.: 33321092247	Ref.Nr.: 33171093175	Ref.Nr.: 33531136395	Ref.Nr.: 6778544
<b>F8-6215</b>	<b>F8-6216</b>	<b>F8-6243</b>	<b>F8-6491</b>	<b>F8-6542</b>	<b>F8-6545</b>	<b>F8-6566</b>
Ref.Nr.: 11817837985	Ref.Nr.: 22116750109	Ref.Nr.: 31121096982	Ref.Nr.: 23 71 1 131 664	Ref.Nr.: 1094750	Ref.Nr.: 0146239	Ref.Nr.: 31326769667

**Article Description****Article Nr.****Fitting Position****3 Coupe (E46) 04/1999 → 07/2006**

Belt Pulley, crankshaft	330 Cd	Number of Ribs: 3, 5; Parameter: 6PK + 4PK	<b>F8-7641</b>		
Protective Cap/Bellow, shock absorber	All Models		<b>F8-7684</b>		H=194
Rubber Buffer, suspension	316 Ci, 318 Ci, 320 Cd, 320 Ci, 323 Ci, 325 Ci, 328 Ci, 330 Cd, 330 Ci	<b>SP</b>	<b>F8-7700</b>		H=90
Stabiliser Mounting	318 Ci		<b>F8-7933</b>	⊕ ⊕	d=24,6
Stabiliser Mounting	316 Ci, 318 Ci, 320 Cd, 320 Ci, 323 Ci, 328 Ci, 330 Cd, M3 3.2		<b>F8-7976</b>	⊕ ⊕	D=17
Stabiliser Mounting	318 Ci	N42	<b>F8-7976</b>	⊕ ⊕	D=17
Stabiliser Mounting	320 Ci, 325 Ci, 330 Ci	M54	<b>F8-7976</b>	⊕ ⊕	D=17
Stabiliser Mounting	M3 CSL	S54N	<b>F8-7976</b>	⊕ ⊕	D=17
Engine Mounting	320 Ci, 323 Ci, 325 Ci, 328 Ci, 330 Ci		<b>F8-8174</b>	⊕ ⊕	
Mounting, propshaft	316 Ci, 318 Ci		<b>F8-8226</b>		
Mounting, axle beam	316 Ci, 318 Ci, 320 Cd, 320 Ci, 323 Ci, 325 Ci, 328 Ci, 330 Cd, 330 Ci, 330 xi		<b>F8-8230</b>		
Suspension Kit	316 Ci, 318 Ci, 320 Cd, 320 Ci, 323 Ci, 325 Ci, 328 Ci, 330 Cd, 330 Ci, 330 xi	Aluminium; with fastening material	<b>G8-544</b>	⊕ ⊕ ⊕ ↓	D=66
Bellow, steering	All Models	with clamps;	<b>LM-10011S</b>		d1=37; d2=51; L [mm]=185
Bellow, steering	316 Ci, 318 Ci, 320 Cd, 320 Ci, 323 Ci, 325 Ci, 328 Ci, 330 Cd, 330 Ci, M3 3.2, M3 CSL	with clamps	<b>LM-10078S</b>		d1=15; d2=55; L [mm]=186

**3 Touring (E46) 10/1999 → 02/2005**

Dust Cover Kit, shock absorber	316 i, 318 d, 318 i, 320 d, 320 i, 325 i, 325 xi, 328 i, 330 d, 330 i, 330 xd, 330 xi	<b>ST</b>	<b>AK-735126</b>		
Dust Cover Kit, shock absorber	316 i, 318 d, 318 i, 320 d, 320 i, 325 i, 328 i, 330 d, 330 i	<b>ST</b>	<b>AK-735406</b>		H=136, 86
Dust Cover Kit, shock absorber	316 i, 318 d, 318 i, 320 d, 320 i, 325 i, 328 i, 330 d, 330 i	<b>ST</b>	<b>AK-735407</b>		H=136, 90
Alternator Freewheel Clutch	316 i, 318 i		<b>F5-1051</b>		
Alternator Freewheel Clutch	316 i, 318 i		<b>F5-1053</b>		
Top Strut Mounting	316 i, 318 d, 318 i, 320 d, 320 i, 325 i, 325 xi, 328 i, 330 d, 330 i, 330 xd, 330 xi		<b>F8-5030</b>	⊕ ⊕	H=35; d=10
Holder, control arm mounting	316 i, 318 d, 318 i, 320 d, 320 i, 325 i, 328 i, 330 d, 330 i	Aluminium	<b>F8-5280</b>	⊕ ⊕ ↓	D=66
Holder, control arm mounting	316 i, 318 d, 318 i, 320 d, 320 i, 325 i, 328 i, 330 d, 330 i	Aluminium	<b>F8-5281</b>	⊕ ⊕ ↓	D=66
Control Arm-/Trailing Arm Bush	316 i, 318 d, 318 i, 320 d, 320 i, 325 i, 325 xi, 328 i, 330 d, 330 i, 330 xd, 330 xi		<b>F8-5311</b>	⊕ ⊕	H=49; d=12; D=61
Mounting, axle beam	316 i, 318 d, 318 i, 320 d, 320 i, 325 i, 325 xi, 328 i, 330 d, 330 i, 330 xd, 330 xi		<b>F8-5318</b>	⊕	d=12,5; D=70
Mounting, axle beam	316 i, 318 d, 318 i, 320 d, 320 i, 325 i, 325 xi, 328 i, 330 d, 330 i, 330 xd, 330 xi		<b>F8-5319</b>	⊕	H=66; d=12; D=70.3

<b>AK-735126</b>	<b>AK-735406</b>	<b>AK-735407</b>	<b>F5-1051</b>	<b>F5-1053</b>	<b>F8-5030</b>	<b>F8-5280</b>
Ref.Nr.: 33521136283	Ref.Nr.: 3133-1094750	Ref.Nr.: 3133-1094749	Ref.Nr.: 12317516099	Ref.Nr.: 12314466273	Ref.Nr.: 33504035929	Ref.Nr.: 31124004359
<b>F8-5281</b>	<b>F8-5311</b>	<b>F8-5318</b>	<b>F8-5319</b>	<b>F8-5320</b>	<b>F8-7641</b>	<b>F8-7684</b>
Ref.Nr.: 31126754900	Ref.Nr.: 33321097009	Ref.Nr.: 33311092515	Ref.Nr.: 33311092516	Ref.Nr.: 33311092517	Ref.Nr.: 11237793593	Ref.Nr.: 1136283
<b>F8-7700</b>	<b>F8-7933</b>	<b>F8-7976</b>	<b>F8-8174</b>	<b>F8-8226</b>	<b>F8-8230</b>	<b>G8-544</b>
Ref.Nr.: 33531138109	Ref.Nr.: 31351095271	Ref.Nr.: 33551138104	Ref.Nr.: 23711137817	Ref.Nr.: 26121229317	Ref.Nr.: 33171093565	Ref.Nr.: 31126777849

Article Description



Article Nr.

Fitting Position



### 3 Touring (E46)

10/1999 → 02/2005

Mounting, axle beam	316 i, 318 d, 318 i, 320 d, 320 i, 325 i, 325 xi, 328 i, 330 d, 330 i, 330 xd, 330 xi		F8-5320		H=63; d=20.5; D=72
Tie Bar Bush	318 i, 320 d, 320 i, 328 i		F8-5321		H=57; d=12.2; D=45.4
Control Arm-/Trailing Arm Bush	318 i, 320 d, 320 i, 328 i		F8-5322		H=56.5; d=12.1; D=35.6
Engine Mounting	320 i, 325 i, 328 i, 330 i		F8-5348		
Engine Mounting	316 i, 318 i	N42, N46	F8-5422		
Engine Mounting	318 d, 318 i		F8-5422		
Engine Mounting	318 d, 318 i		F8-5422		
Engine Mounting	320 d		F8-5422		
Engine Mounting	320 d		F8-5422		
Engine Mounting	316 i, 318 i	N42, N46	F8-5423		
Engine Mounting	318 d, 320 d		F8-5423		
Top Strut Mounting	316 i, 318 d, 318 i, 320 d, 320 i, 325 i, 325 xi, 328 i, 330 d, 330 i, 330 xd, 330 xi		F8-5433		
Control Arm-/Trailing Arm Bush	316 i, 318 d, 318 i, 320 d, 320 i, 325 i, 325 xi, 328 i, 330 d, 330 i, 330 xd, 330 xi		F8-5632		H=57; d=12; D=45
Belt Pulley, crankshaft	320 i, 325 i, 325 xi, 330 i, 330 xi	09/2002 →	F8-5661		
Belt Pulley, crankshaft	320 i, 325 i, 325 xi, 328 i		F8-5662		
Belt Pulley, crankshaft	330 i, 330 xi	07/2001 →	F8-5662		
Control Arm-/Trailing Arm Bush	316 i, 318 d, 318 i, 320 d, 320 i, 325 i, 325 xi, 328 i, 330 d, 330 i, 330 xd, 330 xi		F8-5746		H=42, 66.5; d=12; D=35
Mounting, axle beam	316 i, 318 d, 318 i, 320 d, 320 i, 325 i, 325 xi, 328 i, 330 d, 330 i, 330 xd, 330 xi		F8-5886		H1=47; H2=40; D=47
Rubber Buffer, suspension	316 i, 318 d, 318 i, 320 d, 320 i	<b>ST</b> , <b>MT</b> , <b>SP</b>	F8-5963		H=105
Rubber Buffer, suspension	316 i, 318 d, 318 i, 320 d, 320 i, 325 i, 328 i, 330 d, 330 i	<b>SP</b>	F8-6088		H=75
Engine Mounting	325 xi		F8-6215		
Engine Mounting	330 d		F8-6216		
Control Arm-/Trailing Arm Bush	318 i, 320 d, 320 i, 328 i, 330 d, 330 i		F8-6243		H=55; d=20; D=60.4
Mounting, automatic transmission	330 d		F8-6491		H=34; D=36, 50; Outer Thread [mm]=M8 x 1,25mm
Mounting, automatic transmission	330 d	M57 306 D1	F8-6491		H=34; D=36, 50; Outer Thread [mm]=M8 x 1,25mm
Rubber Buffer, suspension	316 i, 318 d, 318 i, 320 d, 320 i, 325 i, 328 i, 330 d, 330 i	<b>ST</b>	F8-6543		H=90
Protective Cap/Bellow, shock absorber	316 i, 318 d, 318 i, 320 d, 320 i, 325 i, 325 xi, 328 i, 330 d, 330 i, 330 xd, 330 xi	Universal	F8-6545		H=140
Spring Cap	316 i, 318 d, 318 i, 320 d, 320 i, 325 i, 325 xi, 328 i, 330 d, 330 i, 330 xd, 330 xi		F8-6566		





**Article Description****Article Nr.****Fitting Position**

<b>3 Touring (E46)</b>				<b>10/1999 → 02/2005</b>	
Joint, propshaft	325 xi, 330 xd, 330 xi		<b>F8-6763</b>		d=50; D=128; Thick./Strength 1 [mm]=39
Mounting, propshaft	318 i		<b>F8-6777</b>		d=30
Engine Mounting	325 xi, 330 xi		<b>F8-6942</b>		
Engine Mounting	320 d		<b>F8-6943</b>		
Protective Cap/Bellow, shock absorber	316 i, 318 d, 318 i, 320 d, 320 i, 325 i, 325 xi, 328 i, 330 d, 330 i, 330 xd, 330 xi	Available as universal article: F8-6545	<b>F8-7336</b>		H=136
Belt Pulley, crankshaft	330 d, 330 xd	Number of Ribs: 3, 5; Parameter: 6PK + 4PK	<b>F8-7641</b>		
Protective Cap/Bellow, shock absorber	316 i, 318 d, 318 i, 320 d, 320 i, 325 i, 325 xi, 328 i, 330 d, 330 i, 330 xd, 330 xi		<b>F8-7684</b>		H=194
Rubber Buffer, suspension	316 i, 318 d, 318 i, 320 d, 320 i, 325 i, 328 i, 330 d, 330 i		<b>F8-7700</b>		H=90
Engine Mounting	325 xi, 330 xd, 330 xi		<b>F8-8163</b>		
Engine Mounting	320 i, 325 i, 328 i, 330 i		<b>F8-8174</b>		
Mounting, propshaft	316 i, 318 i		<b>F8-8226</b>		
Mounting, propshaft	325 xi, 330 xd, 330 xi		<b>F8-8226</b>		
Suspension Kit	316 i, 318 d, 318 i, 320 d, 320 i, 325 i, 328 i, 330 d, 330 i	Aluminium; with fastening material	<b>G8-544</b>		D=66
Bellow, steering	316 i, 318 d, 318 i, 320 d, 320 i, 325 i, 328 i, 330 d, 330 i	with clamps;	<b>LM-10011S</b>		d1=37; d2=51; L [mm]=185
Bellow, steering	316 i, 318 d, 318 i, 320 d, 320 i, 325 i, 328 i, 330 d, 330 i	with clamps	<b>LM-10078S</b>		d1=15; d2=55; L [mm]=186
<b>3 (E90)</b>				<b>01/2005 → 12/2011</b>	
Dust Cover Kit, shock absorber	316 d, 316 i, 318 d, 318 i, 320 d, 320 i, 320 si, 323 i, 325 d, 325 i, 328 i, 330 d, 330 i, 335 d, 335 i		<b>AK-735420</b>		
Dust Cover Kit, shock absorber	316 d, 316 i, 318 d, 318 i, 320 d, 320 d xDrive, 320 i, 320 si, 320 xd, 323 i, 325 d, 325 i, 325 i xDrive, 325 xi, 328 i, 330 d, 330 d xDrive, 330 i, 330 i xDrive, 330 xd, 330 xi, 335 d, 335 i, 335 i xDrive, 335 xi		<b>AK-735421</b>		
Dust Cover Kit, shock absorber	320 d xDrive, 320 xd, 325 i xDrive, 325 xi, 330 d xDrive, 330 i xDrive, 330 xd, 330 xi, 335 i xDrive, 335 xi		<b>AK-735422</b>		
Dust Cover Kit, shock absorber	335i		<b>AK-735427</b>		H=228
Alternator Freewheel Clutch	316 i, 318 i, 320 i		<b>F5-1051</b>		
Alternator Freewheel Clutch	316 i, 318 i, 320 i, 320 si, 323 i, 325 i, 325 i xDrive, 325 xi, 328 i, 330 i, 330 i xDrive, 330 xi		<b>F5-1053</b>		
Top Strut Mounting	316 d, 316 i, 318 d, 318 i, 320 d, 320 d xDrive, 320 i, 320 si, 320 xd, 323 i, 325 d, 325 i, 325 i xDrive, 325 xi, 328 i, 330 d, 330 d xDrive, 330 i, 330 i xDrive, 330 xd, 330 xi, 335 d, 335 i, 335 i xDrive, 335 xi, M3 4.0		<b>F8-5433</b>		

<b>AK-735420</b>	<b>AK-735421</b>	<b>AK-735422</b>	<b>AK-735427</b>	<b>F5-1051</b>	<b>F5-1053</b>	<b>F8-5433</b>
Ref.Nr.: 31336771352	Ref.Nr.: 33503411995	Ref.Nr.: 31306774232	Ref.Nr.: 33536771381	Ref.Nr.: 12317516099	Ref.Nr.: 12314466273	Ref.Nr.: 31331094616
<b>F8-6250</b>	<b>F8-6763</b>	<b>F8-6777</b>	<b>F8-6942</b>	<b>F8-6943</b>	<b>F8-7336</b>	<b>F8-7641</b>
Ref.Nr.: 33326775552	Ref.Nr.: 26111227717	Ref.Nr.: 26121229089	Ref.Nr.: 22116750862	Ref.Nr.: 22116756018	Ref.Nr.: 31331094749	Ref.Nr.: 11237793593
<b>F8-7684</b>	<b>F8-7700</b>	<b>F8-8163</b>	<b>F8-8174</b>	<b>F8-8226</b>	<b>G8-544</b>	<b>LM-10011S</b>
Ref.Nr.: 1136283	Ref.Nr.: 33531138109	Ref.Nr.: 22316750858	Ref.Nr.: 23711137817	Ref.Nr.: 26121229317	Ref.Nr.: 31126777849	Ref.Nr.: 31111137070

### Article Description



### Article Nr.

### Fitting Position



3 (E90)		01/2005 → 12/2011			
Control Arm-/Trailing Arm Bush	316 d, 316 i, 318 d, 318 i, 320 d, 320 d xDrive, 320 i, 320 si, 320 xd, 323 i, 325 d, 325 i, 325 i xDrive, 325 xi, 328 i, 330 d, 330 d xDrive, 330 i, 330 i xDrive, 330 xd, 330 xi, 335 d, 335 i, 335 i xDrive, 335 xi, M3 4.0		<b>F8-6250</b>		H=55; d=14; D=47
Control Arm-/Trailing Arm Bush	316 i, 318 d, 318 i, 320 d, 320 d xDrive, 320 i, 320 si, 320 xd, 325 d, 325 i, 325 i xDrive, 325 xi, 330 d, 330 d xDrive, 330 i, 330 i xDrive, 330 xd, 330 xi, 335 d, 335 i, 335 i xDrive, 335 xi		<b>F8-6252</b>		H1=49.5; H2=33; d=12.2; D=45.3
Mounting, axle bracket	316 i, 318 d, 318 i, 320 d, 320 d xDrive, 320 i, 320 si, 323 i, 325 d, 325 i, 325 xi, 328 i, 330 d, 330 d xDrive, 330 i, 330 xd, 330 xi, 335 d, 335 i, 335 xi, M3 4.0		<b>F8-6476</b>		
Protective Cap/Bellow, shock absorber	316 d, 316 i, 318 d, 318 i, 320 d, 320 d xDrive, 320 i, 320 si, 320 xd, 323 i, 325 d, 325 i, 325 i xDrive, 325 xi, 328 i, 330 d, 330 d xDrive, 330 i, 330 i xDrive, 330 xd, 330 xi, 335 d, 335 i, 335 i xDrive, 335 xi, 335i, M3 4.0	Universal	<b>F8-6545</b>		H=140
Control Arm-/Trailing Arm Bush	316 i, 318 d, 318 i, 320 d, 320 i, 320 si, 323 i, 325 d, 325 i, 328 i, 330 d, 330 i, 335 d, 335 i, 335i		<b>F8-6724</b>		d=12; L1=64.5; L2=76; D=70
Joint, propshaft	325 d, 330 d		<b>F8-6764</b>		d=44.5; D=155; Thick./Strength 1 [mm]=30
Joint, propshaft	318 d, 320 d, 320 d xDrive, 320 xd, 325 i xDrive, 325 xi, 330 i, 330 i xDrive, 330 xi		<b>F8-6768</b>		
Engine Mounting	325 xi, 330 i, 330 i xDrive, 330 xi, 335 i xDrive		<b>F8-6998</b>		
Engine Mounting	316 d, 318 d, 320 d	Aluminium	<b>F8-6999</b>		
Engine Mounting	316 d, 318 d, 320 d	Aluminium	<b>F8-7000</b>		
Engine Mounting	316 i, 318 i, 320 i, 320 si		<b>F8-7001</b>		
Engine Mounting	316 i, 318 i, 320 i, 320 si		<b>F8-7002</b>		
Engine Mounting	330 d xDrive, 330 xd		<b>F8-7003</b>		
Engine Mounting	325 d, 330 d, 335 d		<b>F8-7004</b>		
Engine Mounting	325 d, 330 d, 335 d		<b>F8-7005</b>		
Mounting, axle bracket	316 i, 318 i, 320 i, 320 si, 325 i, 325 i xDrive, 325 xi, 330 i, 330 i xDrive, 330 xi, 335 i, 335 i xDrive, 335 xi		<b>F8-7145</b>		
Protective Cap/Bellow, shock absorber	316 d, 316 i, 318 d, 318 i, 320 d, 320 d xDrive, 320 i, 320 si, 320 xd, 323 i, 325 d, 325 i, 325 i xDrive, 325 xi, 328 i, 330 d, 330 d xDrive, 330 i, 330 i xDrive, 330 xd, 330 xi, 335 d, 335 i, 335 i xDrive, 335 xi, 335i, M3 4.0	Available as universal article: F8-6545	<b>F8-7336</b>		H=136
Belt Pulley, crankshaft	325 d, 330 d, 330 xd, 335 d	Number of Ribs: 3, 5; Parameter: 6PK + 4PK	<b>F8-7641</b>		
Rubber Buffer, suspension	316 d, 316 i, 318 d, 318 i, 320 d, 320 i, 325 d, 325 i, 330 d, 330 i		<b>F8-7709</b>		H=218
Rubber Buffer, suspension	316 i, 318 i, 320 d, 320 i, 323 i, 325 d, 325 i, 330 d, 330 i, 335 d, 335 i		<b>F8-7709</b>		H=218
Rubber Buffer, suspension	320 d	03/2007 →	<b>F8-7709</b>		H=218
Rubber Buffer, suspension	323 i, 325 d, 325 i, 330 d, 330 i, 335 d, 335 i	04/2007 →	<b>F8-7709</b>		H=218



**Article Description****Article Nr.****Fitting Position**

<b>3 (E90)</b>		<b>01/2005 → 12/2011</b>			
Top Strut Mounting	316 d, 316 i, 318 d, 318 i, 320 d, 320 d xDrive, 320 i, 320 si, 320 xd, 323 i, 325 d, 325 i, 325 i xDrive, 325 xi, 328 i, 330 d, 330 d xDrive, 330 i, 330 i xDrive, 330 xd, 330 xi, 335 d, 335 i, 335 i xDrive, 335 xi, M3 4.0	Lower Section	<b>F8-7723</b>		
Top Strut Mounting	316 d, 316 i, 318 d, 318 i, 320 d, 320 d xDrive, 320 i, 320 si, 320 xd, 323 i, 325 d, 325 i, 325 i xDrive, 325 xi, 328 i, 330 d, 330 d xDrive, 330 i, 330 i xDrive, 330 xd, 330 xi, 335 d, 335 i, 335 i xDrive, 335 xi, M3 4.0	Upper section	<b>F8-7724</b>		
Rubber Buffer, suspension	316 d, 316 i, 318 d, 318 i, 320 d, 320 d xDrive, 320 i, 320 si, 320 xd, 323 i, 325 d, 325 i, 325 i xDrive, 325 xi, 328 i, 330 d, 330 d xDrive, 330 i, 330 i xDrive, 330 xd, 330 xi, 335 d, 335 i, 335 i xDrive, 335 xi	<b>ST</b>	<b>F8-7725</b>		
Rubber Buffer, suspension	316 d, 316 i, 318 d, 318 i, 320 d, 320 i, 320 xd, 323 i, 325 d, 325 i, 328 i, 330 d, 330 i, 335 d, 335 i	<b>ST</b>	<b>F8-7812</b>		H=80
Rubber Buffer, suspension	335i	<b>ST</b>	<b>F8-7846</b>	⊕ ⊕	H=85
Stabiliser Mounting	316 d, 316 i, 318 d, 318 i, 320 d, 320 i, 320 si, 320 xd, 323 i, 325 d, 325 i, 325 xi, 328 i, 330 d, 330 i, 330 xi, 335 d, 335 i, 335 xi		<b>F8-7931</b>	⊕ ⊕	d=26,5
Engine Mounting	320 d xDrive, 320 xd, 325 i xDrive, 325 xi, 330 d xDrive, 330 i xDrive, 330 xd, 330 xi, 335 i xDrive, 335 xi		<b>F8-8163</b>	↓	
Engine Mounting	316 i, 318 d, 318 i, 320 d, 320 i, 320 si, 325 d, 325 i, 330 d, 330 i, 335 d, 335 i		<b>F8-8174</b>	⊕ ⊕	
Mounting, axle beam	318 d, 320 d, 320 d xDrive, 320 xd, 325 d, 330 d, 330 d xDrive, 330 xd, 335 d		<b>F8-8230</b>		
<b>3 Convertible (E93)</b>		<b>03/2007 → 12/2013</b>			
Dust Cover Kit, shock absorber	320 d, 320 i, 323 i, 325 d, 325 i, 330 d, 330 i, 335 i	<b>ST</b>	<b>AK-735420</b>		
Dust Cover Kit, shock absorber	320 d, 320 i, 323 i, 325 d, 325 i, 330 d, 330 i, 335 i	<b>ST</b>	<b>AK-735423</b>		
Alternator Freewheel Clutch	320 i		<b>F5-1051</b>		
Alternator Freewheel Clutch	323 i, 325 i, 330 i		<b>F5-1053</b>		
Top Strut Mounting	318 i, 320 d, 320 i, 323 i, 325 d, 325 i, 330 d, 330 i, 335 i, M3		<b>F8-5433</b>	⊕ ⊕	
Control Arm-/Trailing Arm Bush	318 i, 320 d, 320 i, 323 i, 325 d, 325 i, 330 d, 330 i, 335 i, M3		<b>F8-6250</b>	⊕ ⊕ ↓	H=55; d=14; D=47
Control Arm-/Trailing Arm Bush	320 d, 320 i, 325 d, 325 i, 330 d, 330 i, 335 i		<b>F8-6252</b>	⊕ ⊕	H1=49.5; H2=33; d=12.2; D=45.3
Mounting, axle bracket	320 d, 320 i, 323 i, 325 d, 325 i, 330 d, 330 i, 335 i, M3		<b>F8-6476</b>	⊕ ⊕	
Protective Cap/Bellow, shock absorber	320 d, 320 i, 323 i, 325 d, 325 i, 330 d, 330 i, 335 i, M3	Universal	<b>F8-6545</b>	⊕ ⊕	H=140
Control Arm-/Trailing Arm Bush	320 d, 320 i, 323 i, 325 d, 325 i, 330 d, 330 i, 335 i		<b>F8-6724</b>	⊕ ⊕ ↑	d=12; L1=64.5; L2=76; D=70
Joint, propshaft	325 d, 330 d		<b>F8-6764</b>		d=44.5; D=155; Thick./Strength 1 [mm]=30
Joint, propshaft	320 d, 330 i		<b>F8-6768</b>		

<b>AK-735420</b>	<b>AK-735423</b>	<b>F5-1051</b>	<b>F5-1053</b>	<b>F8-5433</b>	<b>F8-6250</b>	<b>F8-6252</b>
Ref.Nr.: 31336771352	Ref.Nr.: 33506773628	Ref.Nr.: 12317516099	Ref.Nr.: 12314466273	Ref.Nr.: 31331094616	Ref.Nr.: 33326775552	Ref.Nr.: 33326763473-PA
<b>F8-6476</b>	<b>F8-6545</b>	<b>F8-6724</b>	<b>F8-6764</b>	<b>F8-6768</b>	<b>F8-6998</b>	<b>F8-7723</b>
Ref.Nr.: 33326763092	Ref.Nr.: 0146239	Ref.Nr.: 31120393540	Ref.Nr.: 26117542238	Ref.Nr.: 26117527392	Ref.Nr.: 22116760330	Ref.Nr.: 33506771738
<b>F8-7724</b>	<b>F8-7725</b>	<b>F8-7812</b>	<b>F8-7846</b>	<b>F8-7931</b>	<b>F8-8163</b>	<b>F8-8174</b>
Ref.Nr.: 33506771737	Ref.Nr.: 33536767334	Ref.Nr.: 31336771352	Ref.Nr.: 31336771380	Ref.Nr.: 31356765574	Ref.Nr.: 22316750858	Ref.Nr.: 23711137817

Article Description



Article Nr.

Fitting Position



### 3 Convertible (E93)

03/2007 → 12/2013

Engine Mounting	325 i, 330 i, 335 i		F8-6998	↔ ↔	
Engine Mounting	320 d	Aluminium	F8-6999	↔	
Engine Mounting	320 d	Aluminium	F8-7000	↔	
Engine Mounting	320 i		F8-7001	↔	
Engine Mounting	320 i		F8-7002	↔	
Engine Mounting	325 d, 330 d		F8-7004	↔	
Engine Mounting	325 d, 330 d		F8-7005	↔	
Mounting, axle bracket	320 i, 325 i, 330 i, 335 i		F8-7145	↔ ↔ ↔	
Protective Cap/Bellow, shock absorber	320 d, 320 i, 323 i, 325 d, 325 i, 330 d, 330 i, 335 i, M3	Available as universal article: F8-6545	F8-7336	↔ ↔ ↔	H=136
Belt Pulley, crankshaft	325 d, 330 d	Number of Ribs: 3, 5; Parameter: 6PK + 4PK	F8-7641		
Rubber Buffer, suspension	318 i, 320 d, 320 i, 323 i, 325 d, 325 i, 330 d, 330 i, 335 i, M3	ST, MT, SP	F8-7702	↔	H=228
Rubber Buffer, suspension	318 i, 320 d, 320 i, 323 i, 325 d, 325 i, 330 d, 330 i	MT	F8-7709	↔	H=218
Top Strut Mounting	318 i, 320 d, 320 i, 323 i, 325 d, 325 i, 330 d, 330 i, 335 i, M3	Lower Section	F8-7723	↔	
Top Strut Mounting	318 i, 320 d, 320 i, 323 i, 325 d, 325 i, 330 d, 330 i, 335 i, M3	Upper section	F8-7724	↔	
Rubber Buffer, suspension	318 i, 320 d, 320 i, 323 i, 325 d, 325 i, 330 d, 330 i, 335 i	ST	F8-7812	↔	H=80
Rubber Buffer, suspension	320 d, 325 d, 330 d, 335 i	06/2010 →; ST	F8-7846	↔ ↔ ↔	H=85
Engine Mounting	320 i, 323 i, 325 d, 325 i, 330 d, 330 i, 335 i		F8-8174	↔ ↔	
Mounting, axle beam	320 d, 325 d, 330 d		F8-8230	↔	

### 3 Coupe (E92)

06/2006 → 12/2013

Dust Cover Kit, shock absorber	320 d, 320 i, 323 i, 325 d, 325 i, 328 i, 330 d, 330 i, 335 d, 335 i	ST	AK-735420	↔	
Dust Cover Kit, shock absorber	320 d, 320 d xDrive, 320 i, 320 xd, 323 i, 325 d, 325 i, 325 i xDrive, 325 xi, 328 i, 330 d, 330 d xDrive, 330 i, 330 i xDrive, 330 xd, 330 xd X, 330 xi, 335 d, 335 i, 335 i xDrive, 335 xi	ST	AK-735421	↔	
Alternator Freewheel Clutch	320 i		F5-1051		
Alternator Freewheel Clutch	320 i, 323 i, 325 i, 325 i xDrive, 325 xi, 328 i, 330 i, 330 i xDrive, 330 xi		F5-1053		
Top Strut Mounting	316 i, 318 i, 320 d, 320 d xDrive, 320 i, 320 xd, 323 i, 325 d, 325 i, 325 i xDrive, 325 xi, 328 i, 330 d, 330 d xDrive, 330 i, 330 i xDrive, 330 xd, 330 xd X, 330 xi, 335 d, 335 i, 335 i xDrive, 335 xi, M	⚙	F8-5433	↔ ↔ ↔	
Control Arm-/Trailing Arm Bush	316 i, 318 i, 320 d, 320 d xDrive, 320 i, 320 xd, 323 i, 325 d, 325 i, 325 i xDrive, 325 xi, 328 i, 330 d, 330 d xDrive, 330 i, 330 i xDrive, 330 xd, 330 xd X, 330 xi, 335 d, 335 i, 335 i xDrive, 335 xi, M, M GTS		F8-6250	↔ ↔ ↔ ↓	H=55; d=14; D=47

<b>AK-735420</b>	<b>AK-735421</b>	<b>F5-1051</b>	<b>F5-1053</b>	<b>F8-5433</b>	<b>F8-6250</b>	<b>F8-6252</b>
Ref.Nr.: 31336771352	Ref.Nr.: 33503411995	Ref.Nr.: 12317516099	Ref.Nr.: 12314466273	Ref.Nr.: 31331094616	Ref.Nr.: 33326775552	Ref.Nr.: 33326763473-PA
<b>F8-6998</b>	<b>F8-6999</b>	<b>F8-7000</b>	<b>F8-7001</b>	<b>F8-7002</b>	<b>F8-7004</b>	<b>F8-7005</b>
Ref.Nr.: 22116760330	Ref.Nr.: 22116768799	Ref.Nr.: 22116768800	Ref.Nr.: 22116768852	Ref.Nr.: 22116768853	Ref.Nr.: 22114038371	Ref.Nr.: 22114038372
<b>F8-7145</b>	<b>F8-7336</b>	<b>F8-7641</b>	<b>F8-7702</b>	<b>F8-7709</b>	<b>F8-7723</b>	<b>F8-7724</b>
Ref.Nr.: 33316758260	Ref.Nr.: 31331094749	Ref.Nr.: 11237793593	Ref.Nr.: 33506773628	Ref.Nr.: 33534035353	Ref.Nr.: 33506771738	Ref.Nr.: 33506771737

**Article Description****Article Nr.****Fitting Position**

<b>3 Coupe (E92)</b>		<b>06/2006 → 12/2013</b>		
Control Arm-/Trailing Arm Bush	320 d, 320 d xDrive, 320 i, 320 xd, 325 d, 325 i, 325 i xDrive, 325 xi, 330 d, 330 d xDrive, 330 i, 330 i xDrive, 330 xd, 330 xd X, 330 xi, 335 d, 335 i, 335 i xDrive, 335 xi		F8-6252	H1=49.5; H2=33; d=12.2; D=45.3
Mounting, axle bracket	320 d, 320 i, 320 xd, 323 i, 325 d, 325 i, 325 xi, 330 d, 330 i, 330 i xDrive, 330 xd, 330 xd X, 330 xi, 335 d, 335 i, 335 xi, M		F8-6476	
Protective Cap/Bellow, shock absorber	320 d, 320 d xDrive, 320 i, 320 xd, 323 i, 325 d, 325 i, 325 i xDrive, 325 xi, 328 i, 330 d, 330 d xDrive, 330 i, 330 i xDrive, 330 xd, 330 xd X, 330 xi, 335 d, 335 i, 335 i xDrive, 335 xi, M	Universal	F8-6545	H=140
Control Arm-/Trailing Arm Bush	320 d, 320 d xDrive, 320 i, 323 i, 325 d, 325 i, 328 i, 330 d, 330 i, 335 d, 335 i		F8-6724	d=12; L1=64.5; L2=76; D=70
Joint, propshaft	325 d, 330 d		F8-6764	d=44.5; D=155; Thick./Strength 1 [mm]=30
Joint, propshaft	320 d, 320 d xDrive, 320 xd, 325 i xDrive, 325 xi, 330 i, 330 i xDrive, 330 xi		F8-6768	
Engine Mounting	325 i, 325 xi, 330 i, 330 i xDrive, 330 xi, 335 i, 335 xi		F8-6998	
Engine Mounting	320 d	Aluminium	F8-6999	
Engine Mounting	320 d	Aluminium	F8-7000	
Engine Mounting	320 i		F8-7001	
Engine Mounting	320 i		F8-7002	
Engine Mounting	330 d xDrive, 330 xd, 330 xd X		F8-7003	
Engine Mounting	325 d, 330 d, 335 d		F8-7004	
Engine Mounting	325 d, 330 d, 335 d		F8-7005	
Mounting, axle bracket	320 i, 325 i, 325 i xDrive, 325 xi, 330 i, 330 i xDrive, 330 xi, 335 i, 335 i xDrive, 335 xi		F8-7145	
Protective Cap/Bellow, shock absorber	320 d, 320 d xDrive, 320 i, 320 xd, 323 i, 325 d, 325 i, 325 i xDrive, 325 xi, 328 i, 330 d, 330 d xDrive, 330 i, 330 i xDrive, 330 xd, 330 xd X, 330 xi, 335 d, 335 i, 335 i xDrive, 335 xi, M	Available as universal article: F8-6545	F8-7336	H=136
Belt Pulley, crankshaft	325 d, 330 d, 335 d	Number of Ribs: 3, 5; Parameter: 6PK + 4PK	F8-7641	
Rubber Buffer, suspension	316 i, 318 i, 320 d, 320 i, 323 i, 325 d, 325 i, 330 d, 330 i, 335 i	MT	F8-7709	H=218
Rubber Buffer, suspension	323 i, 325 i, 330 d, 330 i	SP	F8-7709	H=218
Rubber Buffer, suspension	335 d		F8-7709	H=218
Top Strut Mounting	316 i, 318 i, 320 d, 320 d xDrive, 320 i, 320 xd, 323 i, 325 d, 325 i, 325 i xDrive, 325 xi, 328 i, 330 d, 330 d xDrive, 330 i, 330 i xDrive, 330 xd, 330 xd X, 330 xi, 335 d, 335 i, 335 i xDrive, 335 xi, M	Lower Section	F8-7723	

<b>F8-6252</b>	<b>F8-6476</b>	<b>F8-6545</b>	<b>F8-6724</b>	<b>F8-6764</b>	<b>F8-6768</b>	<b>F8-6998</b>
Ref.Nr.: 33326763473-PA	Ref.Nr.: 33326763092	Ref.Nr.: 0146239	Ref.Nr.: 31120393540	Ref.Nr.: 26117542238	Ref.Nr.: 26117527392	Ref.Nr.: 22116760330
<b>F8-6999</b>	<b>F8-7000</b>	<b>F8-7001</b>	<b>F8-7002</b>	<b>F8-7003</b>	<b>F8-7004</b>	<b>F8-7005</b>
Ref.Nr.: 22116768799	Ref.Nr.: 22116768800	Ref.Nr.: 22116768852	Ref.Nr.: 22116768853	Ref.Nr.: 22114049050	Ref.Nr.: 22114038371	Ref.Nr.: 22114038372
<b>F8-7145</b>	<b>F8-7336</b>	<b>F8-7641</b>	<b>F8-7709</b>	<b>F8-7723</b>	<b>F8-7724</b>	
Ref.Nr.: 33316758260	Ref.Nr.: 31331094749	Ref.Nr.: 11237793593	Ref.Nr.: 33534035353	Ref.Nr.: 33506771738	Ref.Nr.: 33506771737	

Article Description



Article Nr.

Fitting Position



### 3 Coupe (E92)

06/2006 → 12/2013

Top Strut Mounting	316 i, 318 i, 320 d, 320 d xDrive, 320 i, 320 xd, 323 i, 325 d, 325 i, 325 i xDrive, 325 xi, 328 i, 330 d, 330 d xDrive, 330 i, 330 i xDrive, 330 xd, 330 xd X, 330 xi, 335 d, 335 i, 335 i xDrive, 335 xi, M	Upper section	F8-7724		
Rubber Buffer, suspension	320 d, 320 d xDrive, 320 i, 320 xd, 323 i, 325 d, 325 i, 325 i xDrive, 325 xi, 328 i, 330 d, 330 d xDrive, 330 i, 330 i xDrive, 330 xd, 330 xd X, 330 xi, 335 d, 335 i, 335 i xDrive, 335 xi	ST	F8-7725		
Rubber Buffer, suspension	316 i, 318 i, 320 d, 320 i, 323 i, 325 d, 325 i, 328 i, 330 d, 330 i, 335 d, 335 i	ST	F8-7812		H=80
Stabiliser Mounting	320 d, 320 i, 320 xd, 323 i, 325 d, 325 i, 325 xi, 328 i, 330 d, 330 i, 330 xd, 330 xd X, 330 xi, 335 d, 335 i, 335 xi		F8-7931		d=26,5
Engine Mounting	320 d xDrive, 320 xd, 325 i xDrive, 325 xi, 330 d xDrive, 330 i xDrive, 330 xd, 330 xd X, 330 xi, 335 i xDrive, 335 xi		F8-8163		
Engine Mounting	320 i, 325 d, 325 i, 330 d, 330 i, 335 d, 335 i		F8-8174		
Mounting, axle beam	320 d, 320 d xDrive, 320 xd, 325 d, 330 d, 330 d xDrive, 330 xd, 330 xd X, 335 d		F8-8230		

### 3 Touring (E91)

09/2005 → 06/2012

Dust Cover Kit, shock absorber	316 i, 318 d, 318 i, 320 d, 320 d xDrive, 320 i, 320 xd, 320d xDrive, 323 i, 325 d, 325 i, 325 i xDrive, 325 xi, 330 d, 330 i, 330 i xDrive, 330 xd, 330 xi, 335 d, 335 i, 335 i xDrive, 335 xi	ST	AK-735423		
Dust Cover Kit, shock absorber	316 i, 318 i, 320 d xDrive, 320 i, 320 xd, 320d xDrive, 325 i xDrive, 325 xi, 330 i xDrive, 330 xd, 330 xi, 335 i xDrive, 335 xi	ST	AK-735424		
Dust Cover Kit, shock absorber	318 d, 320 d, 325 d, 325 i, 330 d, 330 i, 335 d, 335 i	ST	AK-735425		
Alternator Freewheel Clutch	318 i	N46	F5-1051		
Alternator Freewheel Clutch	318 i, 320 i		F5-1051		
Alternator Freewheel Clutch	318 i	N46	F5-1053		
Alternator Freewheel Clutch	318 i, 320 i, 323 i, 325 i, 325 i xDrive, 325 xi, 330 i, 330 i xDrive, 330 xi		F5-1053		
Top Strut Mounting	316 d, 316 i, 318 d, 318 i, 320 d, 320 d xDrive, 320 i, 320 xd, 320d xDrive, 323 i, 325 d, 325 i, 325 i xDrive, 325 xi, 330 d, 330 i, 330 i xDrive, 330 xd, 330 xi, 335 d, 335 i, 335 i xDrive, 335 xi		F8-5433		
Control Arm-/Trailing Arm Bush	316 d, 316 i, 318 d, 318 i, 320 d, 320 d xDrive, 320 i, 320 xd, 320d xDrive, 323 i, 325 d, 325 i, 325 i xDrive, 325 xi, 330 d, 330 i, 330 i xDrive, 330 xd, 330 xi, 335 d, 335 i, 335 i xDrive, 335 xi		F8-6250		H=55; d=14; D=47
Control Arm-/Trailing Arm Bush	318 d, 318 i, 320 d, 320 i, 320 xd, 320d xDrive, 325 d, 325 i, 325 i xDrive, 325 xi, 330 d, 330 i, 330 i xDrive, 330 xd, 330 xi, 335 d, 335 i, 335 i xDrive, 335 xi		F8-6252		H1=49.5; H2=33; d=12.2; D=45.3

<b>AK-735423</b>	<b>AK-735424</b>	<b>AK-735425</b>	<b>F5-1051</b>	<b>F5-1053</b>	<b>F8-5433</b>	<b>F8-6250</b>
Ref.Nr.: 33506773628	Ref.Nr.: 31331094749	Ref.Nr.: 31331094749	Ref.Nr.: 12317516099	Ref.Nr.: 12314466273	Ref.Nr.: 31331094616	Ref.Nr.: 33326775552
<b>F8-6252</b>	<b>F8-6476</b>	<b>F8-7724</b>	<b>F8-7725</b>	<b>F8-7812</b>	<b>F8-7931</b>	<b>F8-8163</b>
Ref.Nr.: 33326763473-PA	Ref.Nr.: 33326763092	Ref.Nr.: 33506771737	Ref.Nr.: 33536767334	Ref.Nr.: 31336771352	Ref.Nr.: 31356765574	Ref.Nr.: 22316750858
<b>F8-8174</b>	<b>F8-8230</b>					
Ref.Nr.: 23711137817	Ref.Nr.: 33171093565					

**Article Description****Article Nr.****Fitting Position****3 Touring (E91)****09/2005 → 06/2012**

Mounting, axle bracket	316 i, 318 d, 318 i, 320 d, 320 i, 320 xd, 323 i, 325 d, 325 i, 325 xi, 330 d, 330 i, 330 xd, 330 xi, 335 d, 335 i, 335 xi		<b>F8-6476</b>				
Protective Cap/Bellow, shock absorber	316 i, 318 d, 318 i, 320 d, 320 d xDrive, 320 i, 320 xd, 320d xDrive, 323 i, 325 d, 325 i, 325 i xDrive, 325 xi, 330 d, 330 i, 330 i xDrive, 330 xd, 330 xi, 335 d, 335 i, 335 i xDrive, 335 xi	Universal	<b>F8-6545</b>				H=140
Control Arm-/Trailing Arm Bush	316 i, 318 d, 318 i, 320 d, 320 i, 323 i, 325 d, 325 i, 330 d, 330 i, 335 d, 335 i		<b>F8-6724</b>				d=12; L1=64.5; L2=76; D=70
Joint, propshaft	325 d, 330 d		<b>F8-6764</b>				d=44.5; D=155; Thick./Strength 1 [mm]=30
Joint, propshaft	318 d, 320 d, 320 xd, 320d xDrive, 325 i xDrive, 325 xi, 330 i, 330 i xDrive, 330 xi		<b>F8-6768</b>				
Engine Mounting	325 i, 325 xi, 330 i, 330 xi, 335 i, 335 xi		<b>F8-6998</b>				
Engine Mounting	316 d, 318 d, 320 d	Aluminium	<b>F8-6999</b>				
Engine Mounting	316 d, 318 d, 320 d	Aluminium	<b>F8-7000</b>				
Engine Mounting	318 i, 320 i		<b>F8-7001</b>				
Engine Mounting	318 i, 320 i		<b>F8-7002</b>				
Engine Mounting	330 xd		<b>F8-7003</b>				
Engine Mounting	325 d, 330 d, 335 d		<b>F8-7004</b>				
Engine Mounting	325 d, 330 d, 335 d		<b>F8-7005</b>				
Mounting, axle bracket	316 i, 318 i, 320 i, 335 i		<b>F8-7145</b>				
Protective Cap/Bellow, shock absorber	316 i, 318 d, 318 i, 320 d, 320 d xDrive, 320 i, 320 xd, 320d xDrive, 323 i, 325 d, 325 i, 325 i xDrive, 325 xi, 330 d, 330 i, 330 i xDrive, 330 xd, 330 xi, 335 d, 335 i, 335 i xDrive, 335 xi	Available as universal article: F8-6545	<b>F8-7336</b>				H=136
Belt Pulley, crankshaft	325 d, 330 d, 330 xd, 335 d	Number of Ribs: 3, 5; Parameter: 6PK + 4PK	<b>F8-7641</b>				
Rubber Buffer, suspension	316 d, 316 i, 318 d, 318 i, 320 d, 320 d xDrive, 320 i, 320 xd, 320d xDrive, 323 i, 325 d, 325 i, 325 i xDrive, 325 xi, 330 d, 330 i, 330 i xDrive, 330 xd, 330 xi, 335 d, 335 i, 335 i xDrive, 335 xi	<b>ST</b> , <b>MT</b> , <b>SP</b>	<b>F8-7702</b>				H=228
Rubber Buffer, suspension	316 i, 318 i, 320 i	<b>MT</b>	<b>F8-7709</b>				H=218
Rubber Buffer, suspension	318 i, 320 i	<b>SP</b>	<b>F8-7709</b>				H=218
Top Strut Mounting	316 d, 316 i, 318 d, 318 i, 320 d, 320 d xDrive, 320 i, 320 xd, 320d xDrive, 323 i, 325 d, 325 i, 325 i xDrive, 325 xi, 330 d, 330 i, 330 i xDrive, 330 xd, 330 xi, 335 d, 335 i, 335 i xDrive, 335 xi	Lower Section	<b>F8-7723</b>				
Top Strut Mounting	316 d, 316 i, 318 d, 318 i, 320 d, 320 d xDrive, 320 i, 320 xd, 320d xDrive, 323 i, 325 d, 325 i, 325 i xDrive, 325 xi, 330 d, 330 i, 330 i xDrive, 330 xd, 330 xi, 335 d, 335 i, 335 i xDrive, 335 xi	Upper section	<b>F8-7724</b>				
Rubber Buffer, suspension	316 i, 318 i, 320 i	03/2010 →; <b>ST</b>	<b>F8-7812</b>				H=80

<b>F8-6476</b>	<b>F8-6545</b>	<b>F8-6724</b>	<b>F8-6764</b>	<b>F8-6768</b>	<b>F8-6998</b>	<b>F8-6999</b>
Ref.Nr.: 33326763092	Ref.Nr.: 0146239	Ref.Nr.: 31120393540	Ref.Nr.: 26117542238	Ref.Nr.: 26117527392	Ref.Nr.: 22116760330	Ref.Nr.: 22116768799
<b>F8-7000</b>	<b>F8-7001</b>	<b>F8-7002</b>	<b>F8-7003</b>	<b>F8-7004</b>	<b>F8-7005</b>	<b>F8-7145</b>
Ref.Nr.: 22116768800	Ref.Nr.: 22116768852	Ref.Nr.: 22116768853	Ref.Nr.: 22114049050	Ref.Nr.: 22114038371	Ref.Nr.: 22114038372	Ref.Nr.: 33316758260
<b>F8-7336</b>	<b>F8-7641</b>	<b>F8-7702</b>	<b>F8-7709</b>	<b>F8-7723</b>	<b>F8-7724</b>	<b>F8-7812</b>
Ref.Nr.: 31331094749	Ref.Nr.: 11237793593	Ref.Nr.: 33506773628	Ref.Nr.: 33534035353	Ref.Nr.: 33506771738	Ref.Nr.: 33506771737	Ref.Nr.: 31336771352

**Article Description**

**Article Nr.**
**Fitting Position**

<b>3 Touring (E91)</b>		<b>09/2005 → 06/2012</b>	
Rubber Buffer, suspension	316 i, 318 i, 320 i	<b>ST</b>	<b>F8-7846</b>
Stabiliser Mounting	316 i, 318 d, 318 i, 320 d, 320 i, 320 xd, 323 i, 325 d, 325 i, 325 xi, 330 d, 330 i, 330 xd, 330 xi, 335 d, 335 i, 335 xi		<b>F8-7931</b>
Engine Mounting	320 xd, 320d xDrive, 325 i xDrive, 325 xi, 330 i xDrive, 330 xd, 330 xi, 335 i xDrive, 335 xi		<b>F8-8163</b>
Engine Mounting	318 d, 318 i, 320 d, 320 i, 325 d, 325 i, 330 d, 330 i, 335 d, 335 i		<b>F8-8174</b>
Mounting, axle beam	318 d, 320 d, 320 d xDrive, 320 xd, 320d xDrive, 325 d, 330 d, 330 xd, 335 d		<b>F8-8230</b>
<b>3 (F30, F35, F80)</b>		<b>10/2011 → 07/2015</b>	
Dust Cover Kit, shock absorber	316 d, 316 i, 318 d, 318d xDrive, 320 d, 320 d xDrive, 320 i, 320 i xDrive, 320i, 325 d, 325d, 330d, 330d xDrive, 335 d xDrive, 335 i, 335 i xDrive, ActiveHybrid	SA CodeS2VFA→; <b>MT</b>	<b>AK-735452</b>
Control Arm-/Trailing Arm Bush	316 d, 316 i, 318 d, 320 d, 320 d xDrive, 320 i, 320 i xDrive, 328 i, 328 i xDrive, 335 i, 335 i xDrive, ActiveHybrid		<b>F8-6250</b>
Protective Cap/Bellow, shock absorber	316 d, 316 i, 318 d, 318d xDrive, 320 d, 320 d xDrive, 320 i, 320 i xDrive, 320i, 325d, 328 i, 328 i xDrive, 330d, 330d xDrive, 335 d xDrive, 335 i, 335 i xDrive, ActiveHybrid		<b>F8-7485</b>
Control Arm-/Trailing Arm Bush	316 d, 316 i, 318 d, 320 d, 320 i, 320i, 325d, 328 i, 330d, 335 i, ActiveHybrid		<b>F8-8092</b>
<b>3 Touring (F31)</b>		<b>10/2011 → 07/2015</b>	
Control Arm-/Trailing Arm Bush	316 d, 318 d, 320 d, 320 i, 328 i, 330 d		<b>F8-6250</b>
Protective Cap/Bellow, shock absorber	316 d, 316i, 318 d, 318d xDrive, 320 d, 320 i, 320d, 320d xDrive, 320i xDrive, 325d, 328 i, 328i xDrive, 330 d, 330d xDrive, 335i, 335i xDrive		<b>F8-7485</b>
Control Arm-/Trailing Arm Bush	316 d, 316i, 318 d, 320 d, 320 i, 320d, 325d, 328 i, 330 d, 335 i, 335i		<b>F8-8092</b>
<b>3 GRAN TURISMO (F34)</b>		<b>03/2013 → 07/2015</b>	
Control Arm-/Trailing Arm Bush	318 d, 320 d, 320 i, 320d xDrive, 320i xDrive, 325d, 328 i, 328i xDrive, 335 i, 335i xDrive		<b>F8-6250</b>
Protective Cap/Bellow, shock absorber	318 d, 320 d, 320 i, 320d xDrive, 320i xDrive, 325d, 328 i, 328i xDrive, 335 i, 335i xDrive		<b>F8-7485</b>
Control Arm-/Trailing Arm Bush	318 d, 320 d, 320 i, 325 d, 325d, 328 i, 330 d, 335 i		<b>F8-8092</b>
<b>4 Coupe (F32, F82)</b>		<b>07/2013 → 03/2015</b>	
Control Arm-/Trailing Arm Bush	420 d, 428 i, 428 i xDrive, 435 i, 435 i xDrive		<b>F8-6250</b>
Protective Cap/Bellow, shock absorber	420 d, 428 i, 428 i xDrive, 435 i, 435 i xDrive		<b>F8-7485</b>

<b>AK-735452</b>	<b>F8-6250</b>	<b>F8-7485</b>	<b>F8-7846</b>	<b>F8-7931</b>	<b>F8-8092</b>	<b>F8-8163</b>
Ref.Nr.: 31306791712	Ref.Nr.: 33326775552	Ref.Nr.: 31306791712	Ref.Nr.: 31336771380	Ref.Nr.: 31356765574	Ref.Nr.: 31126851255	Ref.Nr.: 22316750858
<b>F8-8174</b>	<b>F8-8230</b>					
Ref.Nr.: 23711137817	Ref.Nr.: 33171093565					



**Article Description****Article Nr.****Fitting Position**

<b>4 Coupe (F32, F82)</b>		<b>07/2013 → 03/2015</b>	
Control Arm-/Trailing Arm Bush	420 d, 420 i, 425 d, 428 i, 430 d, 435 i	<b>F8-8092</b>	⊕ ⊕ ⊕ H1=95; H2=70; d=12,2; D=70,3
<b>4 Convertible (F33, F83)</b>		<b>10/2013 → 07/2015</b>	
Control Arm-/Trailing Arm Bush	420 d, 420 i, 425 d, 428 i, 430 d, 435 i	<b>F8-8092</b>	⊕ ⊕ ⊕ H1=95; H2=70; d=12,2; D=70,3
<b>4 Gran Coupe (F36)</b>		<b>03/2014 → 03/2015</b>	
Control Arm-/Trailing Arm Bush	418 d, 420 d, 420 i, 428 i, 430 d, 435 i	<b>F8-8092</b>	⊕ ⊕ ⊕ H1=95; H2=70; d=12,2; D=70,3
<b>5 (E12)</b>		<b>08/1972 → 08/1981</b>	
Dust Cover Kit, shock absorber	518, 520, 520 i, 520/6, 525, 528, 528 i, M 3.4	<b>AK-735004</b>	⊕ ⊕ ⊕
Dust Cover Kit, shock absorber	518, 518 i, 520, 520 i, 520/6, 525, 528, 528 i	<b>AK-735015</b>	⊕ ⊕ ⊕
Engine Mounting	520/6	08/1979 →	<b>F8-5432</b> ⊕ ⊕ ⊕ H=48; D=70; Thread Measurement 1: M10; Thread Measurement 2: M10
Engine Mounting	520/6		<b>F8-6757</b> ⊕ ⊕ ⊕ H=48; D=69; Thread Measurement 1: M10; Thread Measurement 2: M10
<b>5 (E28)</b>		<b>06/1981 → 12/1987</b>	
Dust Cover Kit, shock absorber	518, 518 i, 520 i, 524 d, 524 td, 525 e, 525 i, 528 i	<b>AK-735004</b>	⊕ ⊕ ⊕
Dust Cover Kit, shock absorber	518, 518 i, 520 i, 524 d, 524 td, 525 e, 525 i, 528 i	<b>AK-735015</b>	⊕ ⊕ ⊕
Bush, steering arm shaft	518 i, 520 i, 524 d, 524 td, 525 e, 525 i, 528 i, 535 i, M 535 i, M 3.5	09/1986 →	<b>F7-2039</b> H=55; d=10; D1=27; D2=36
Mounting, axle beam	M 3.5		<b>F8-5317</b> d=15; D=80
Top Strut Mounting	518, 518 i, 520 i, 524 d, 524 td, 525 e, 525 i, 528 i, 535 i, M 535 i, M 3.5		<b>F8-5419</b> ⊕ ⊕ ⊕ Bolt Distance [mm]=87; d=14, 31; D=130
Stabiliser Mounting	520 i		<b>F8-5689</b> ⊕ ⊕ ⊕ d=15; L=40; D=34
Rubber Buffer, suspension	518, 518 i, 520 i, 524 d, 524 td, 525 e, 525 i, 528 i		<b>F8-5690</b> ⊕ ⊕ ⊕ H=85
Mounting, axle beam	518, 518 i, 520 i, 524 d, 524 td, 525 e, 525 i, 528 i, 535 i, M 535 i, M 3.5		<b>F8-5741</b> ⊕ ⊕ ⊕ H=85; d=15; D=70
Rubber Buffer, suspension	520 i	for OE: 33531135624	<b>F8-5867</b> ⊕ ⊕ ⊕ H=99
Mounting, automatic transmission	520 i		<b>F8-6491</b> ⊕ ⊕ H=34; D=36, 50; Outer Thread [mm]=M8 x 1,25mm
Control Arm-/Trailing Arm Bush	520 i	09/1982 →;	<b>F8-7352</b> ⊕ ⊕ ⊕ d=12; L=67; D=44
Control Arm-/Trailing Arm Bush	520 i		<b>F8-7352</b> ⊕ ⊕ ⊕ d=12; L=67; D=44
Control Arm-/Trailing Arm Bush	520 i, 524 td, 525 e, 525 i	ABS; 04/1986 →	<b>F8-7352</b> ⊕ ⊕ ⊕ d=12; L=67; D=44
Control Arm-/Trailing Arm Bush	528 i, 535 i, M 535 i, M 3.5	ABS	<b>F8-7352</b> ⊕ ⊕ ⊕ d=12; L=67; D=44
Repair Kit, link	520 i	09/1982 →;	<b>F8-7352S</b> ⊕ ⊕ ⊕ d=12; L=67; D=44

<b>AK-735004</b>	<b>AK-735015</b>	<b>F7-2039</b>	<b>F8-5317</b>	<b>F8-5419</b>	<b>F8-5432</b>	<b>F8-5689</b>
Ref.Nr.:	Ref.Nr.:	Ref.Nr.: 32211136452	Ref.Nr.: 33311128670	Ref.Nr.: 31331124508	Ref.Nr.: 11811132321	Ref.Nr.: 33551131155
<b>F8-5690</b>	<b>F8-5741</b>	<b>F8-5867</b>	<b>F8-6491</b>	<b>F8-6757</b>	<b>F8-7352</b>	<b>F8-7352S</b>
Ref.Nr.: 31331125215	Ref.Nr.: 33311127533	Ref.Nr.: 33531135624	Ref.Nr.: 23 71 1 131 664	Ref.Nr.: 11811132323	Ref.Nr.: 33321123462	Ref.Nr.: 33321123462
<b>F8-8092</b>						
Ref.Nr.: 31126851255						

**Article Description**

**Article Nr.**
**Fitting Position**

<b>5 (E28)</b>			<b>06/1981 → 12/1987</b>		
Repair Kit, link	520 i		<b>F8-7352S</b>		d=12; L=67; D=44
Repair Kit, link	520 i, 524 td, 525 e, 525 i	ABS; 04/1986 →	<b>F8-7352S</b>		d=12; L=67; D=44
Repair Kit, link	528 i, 535 i, M 535 i, M 3.5	ABS	<b>F8-7352S</b>		d=12; L=67; D=44
Protective Cap/Bellow, shock absorber	518 i, 520 i, 524 d, 524 td, 525 e, 525 i, 528 i, 535 i, M 535 i, M 3.5	10/1986 →	<b>F8-7685</b>		H=91
Protective Cap/Bellow, shock absorber	518, 518 i		<b>F8-7685</b>		H=91
Control Arm-/Trailing Arm Bush	520 i, 524 td, 525 e	04/1986 →	<b>G7-767</b>		L=50; Mounting points diam.[mm]=14,1
Control Arm-/Trailing Arm Bush	525 i, 528 i, 535 i, M 535 i, M 3.5		<b>G7-767</b>		L=50; Mounting points diam.[mm]=14,1
Control Arm-/Trailing Arm Bush	All Models		<b>G9-527</b>		H1=42; H2=52; d=12; D=46.5
Control Arm-/Trailing Arm Bush	520 i, 535 i, 535 i, M 535 i		<b>G9-637</b>		H1=37; H2=50; d=14; D=58
Control Arm-/Trailing Arm Bush	M 3.5		<b>G9-637</b>		H1=37; H2=50; d=14; D=58
Control Arm-/Trailing Arm Bush	518, 518 i, 524 d, 524 td, 525 e, 525 i, 528 i		<b>G9-638</b>		H1=37; H2=50; d=14; D=58
Control Arm-/Trailing Arm Bush	520 i, 535 i, M 535 i	not for	<b>G9-638</b>		H1=37; H2=50; d=14; D=58
Control Arm-/Trailing Arm Bush	520 i		<b>G9-639</b>		H1=37; H2=50; d=14; D=58
Control Arm-/Trailing Arm Bush	520 i, 525 e	05/1985 →;	<b>G9-639</b>		H1=37; H2=50; d=14; D=58
Control Arm-/Trailing Arm Bush	524 d, 524 td, 525 i, 528 i		<b>G9-639</b>		H1=37; H2=50; d=14; D=58
Control Arm-/Trailing Arm Bush	535 i, M 535 i		<b>G9-639</b>		H1=37; H2=50; d=14; D=58
<b>5 (E34)</b>			<b>12/1987 → 09/1995</b>		
Dust Cover Kit, shock absorber	518 i, 520 i, 520 i 24V, 524 td, 525 i, 525 i 24V, 525 td, 525 tds, 530 i, 530 i V8, 535 i, 540 i V8		<b>AK-735004</b>		
Bush, steering arm shaft	518 i, 520 i, 520 i 24V, 524 td, 525 i, 525 i 24V, 525 iX 24V, 525 td, 525 tds, 530 i, 530 i V8, 535 i, 540 i V8, M 3.6 CAT, M 3.8		<b>F7-2039</b>		H=55; d=10; D1=27; D2=36
Stabiliser Mounting	518 i, 520 i, 520 i 24V, 524 td, 525 i, 525 i 24V, 525 td, 525 tds, 530 i, 530 i V8, 535 i, 540 i V8		<b>F8-5114</b>		H=60; d=23; D=51
Stabiliser Mounting	518 i, 520 i, 520 i 24V, 524 td, 525 i, 525 i 24V, 525 td, 525 tds, 530 i, 535 i		<b>F8-5115</b>		H=60; d=24; D=51
Bellow, steering	525 iX 24V		<b>F8-5171</b>		Total Br. Drum Height [mm]=185
Mounting, axle beam	518 i, 520 i, 520 i 24V, 525 i, 525 i 24V, 525 iX 24V, 525 td, 525 tds, 530 i, 530 i V8, 535 i, 540 i V8, M 3.6 CAT, M 3.8		<b>F8-5317</b>		d=15; D=80
Engine Mounting	530 i, 530 i V8		<b>F8-5405</b>		



**Article Description****Article Nr.****Fitting Position**

<b>5 (E34)</b>		<b>12/1987 → 09/1995</b>	
Top Strut Mounting	518 i, 520 i, 520 i 24V, 524 td, 525 i, 525 i 24V, 525 iX 24V, 525 td, 525 tds, 530 i, 530 i V8, 535 i, 540 i V8	<b>ST</b>	<b>F8-5416</b>
Top Strut Mounting	518 i, 520 i, 520 i 24V	<b>ST</b>	<b>F8-5419</b> Bolt Distance [mm]=87; d=14, 31; D=130
Top Strut Mounting	525 i, 525 i 24V, 525 td, 525 tds		<b>F8-5419</b> Bolt Distance [mm]=87; d=14, 31; D=130
Engine Mounting	525 td, 525 tds		<b>F8-5431</b>
Stabiliser Mounting	518 i, 520 i, 520 i 24V, 524 td, 525 i, 525 i 24V, 525 td, 525 tds, 530 i, 530 i V8, 535 i, 540 i V8		<b>F8-5689</b> d=15; L=40; D=34
Rubber Buffer, suspension	518 i, 520 i, 520 i 24V, 524 td, 525 i, 525 i 24V, 525 iX 24V, 525 td, 525 tds, 530 i, 530 i V8, 535 i, 540 i V8		<b>F8-5690</b> H=85
Mounting, transfer gear	518 i, 525 i, 525 i 24V, 525 iX 24V, 530 i, 530 i V8, 535 i, 540 i V8, M 3.6 CAT, M 3.8		<b>F8-5771</b>
Control Arm-/Trailing Arm Bush	518 i, 525 i, 525 i 24V, 525 iX 24V, 530 i, 530 i V8, 535 i, 540 i V8, M 3.6 CAT, M 3.8		<b>F8-5772</b> H=60; d=12,5; D=51
Rubber Buffer, suspension	518 i, 520 i, 520 i 24V, 524 td, 525 i, 525 i 24V, 525 iX 24V, 525 td, 525 tds, 530 i, 530 i V8, 535 i, 540 i V8	for OE: 33531135624	<b>F8-5867</b> H=99
Mounting, automatic transmission	520 i, 524 td, 525 i, 525 td, 525 tds, 530 i, 535 i, M 3.6, M 3.6 CAT, M 3.8		<b>F8-6491</b> H=34; D=36, 50; Outer Thread [mm]=M8 x 1,25mm
Engine Mounting	518 i		<b>F8-6741</b>
Joint, propshaft	525 iX 24V		<b>F8-6763</b> d=50; D=128; Thick./Strength 1 [mm]=39
Mounting, propshaft	518 i		<b>F8-6777</b> d=30
Mounting, propshaft	518 i		<b>F8-6778</b>
Joint, propshaft	M 3.5, M 3.6, M 3.6 CAT, M 3.8		<b>F8-6783</b>
Control Arm-/Trailing Arm Bush	518 i	ABS	<b>F8-7352</b> d=12; L=67; D=44
Control Arm-/Trailing Arm Bush	518 i, 520 i, 524 td, 525 iX 24V, 525 td, 525 tds, 530 i, 530 i V8, 540 i V8		<b>F8-7352</b> d=12; L=67; D=44
Control Arm-/Trailing Arm Bush	520 i 24V		<b>F8-7352</b> d=12; L=67; D=44
Control Arm-/Trailing Arm Bush	525 i, 525 i 24V		<b>F8-7352</b> d=12; L=67; D=44
Control Arm-/Trailing Arm Bush	535 i		<b>F8-7352</b> d=12; L=67; D=44
Repair Kit, link	518 i	ABS	<b>F8-7352S</b> d=12; L=67; D=44
Repair Kit, link	518 i, 520 i, 524 td, 525 iX 24V, 525 td, 525 tds, 530 i, 530 i V8, 540 i V8		<b>F8-7352S</b> d=12; L=67; D=44
Repair Kit, link	520 i 24V		<b>F8-7352S</b> d=12; L=67; D=44
Repair Kit, link	525 i, 525 i 24V		<b>F8-7352S</b> d=12; L=67; D=44
Repair Kit, link	535 i		<b>F8-7352S</b> d=12; L=67; D=44
Top Strut Mounting	525 iX 24V		<b>F8-7425</b>

<b>F8-5416</b>	<b>F8-5419</b>	<b>F8-5431</b>	<b>F8-5689</b>	<b>F8-5690</b>	<b>F8-5771</b>	<b>F8-5772</b>
Ref.Nr.: 33521132270	Ref.Nr.: 31331124508	Ref.Nr.: 11811139606	Ref.Nr.: 33551131155	Ref.Nr.: 31331125215	Ref.Nr.: 33311132257	Ref.Nr.: 33171130874
<b>F8-5867</b>	<b>F8-6491</b>	<b>F8-6741</b>	<b>F8-6763</b>	<b>F8-6777</b>	<b>F8-6778</b>	<b>F8-6783</b>
Ref.Nr.: 33531135624	Ref.Nr.: 23 71 1 131 664	Ref.Nr.: 11811141526	Ref.Nr.: 26111227717	Ref.Nr.: 26121229089	Ref.Nr.: 26121229089-PA	Ref.Nr.: 26112226527
<b>F8-7352</b>	<b>F8-7352S</b>	<b>F8-7425</b>	<b>F8-7439</b>			
Ref.Nr.: 33321123462	Ref.Nr.: 33321123462	Ref.Nr.: 3133-1139436	Ref.Nr.: 31331133292			

Article Description



Article Nr.

Fitting Position



5 (E34)		12/1987 → 09/1995			
Top Strut Mounting	518 i	for government vehicles;	<b>F8-7439</b>		d=14
Top Strut Mounting	518 i, 520 i, 520 i 24V, 524 td, 525 i, 525 i 24V, 530 i, 530 i V8, 535 i	; HD↑	<b>F8-7439</b>		d=14
Top Strut Mounting	518 i, 520 i, 520 i 24V, 525 i 24V	; <b>SP</b>	<b>F8-7439</b>		d=14
Top Strut Mounting	520 i, 520 i 24V, 524 td, 525 i, 525 i 24V, 530 i, 535 i	; <b>MT</b> , <b>SP</b>	<b>F8-7439</b>		d=14
Top Strut Mounting	520 i, 520 i 24V, 525 i, 525 i 24V, 530 i	for government vehicles;	<b>F8-7439</b>		d=14
Top Strut Mounting	524 td, 525 i, 525 i 24V, 530 i, 535 i, M 3.6, M 3.6 CAT		<b>F8-7439</b>		d=14
Top Strut Mounting	525 i, 525 i 24V	; ;	<b>F8-7439</b>		d=14
Top Strut Mounting	525 i, 525 i 24V, 530 i, 535 i, M 3.6, M 3.6 CAT	EDC;	<b>F8-7439</b>		d=14
Top Strut Mounting	535 i	; ; ;	<b>F8-7439</b>		d=14
Top Strut Mounting	M 3.6, M 3.6 CAT	; ;	<b>F8-7439</b>		d=14
Top Strut Mounting	518 i	07/1990 →; for government vehicles; ;	<b>F8-7440</b>		d=16
Top Strut Mounting	518 i, 520 i, 520 i 24V, 525 i 24V	07/1990 →; ; <b>SP</b>	<b>F8-7440</b>		d=16
Top Strut Mounting	520 i	07/1990 →; also for administration vehicles;	<b>F8-7440</b>		d=16
Top Strut Mounting	520 i 24V, 524 td, 525 i, 525 i 24V, 525 tds, 530 i, 535 i	07/1990 →; ; <b>MT</b> , <b>SP</b>	<b>F8-7440</b>		d=16
Top Strut Mounting	520 i 24V, 525 i, 525 i 24V	07/1990 →; ; ;	<b>F8-7440</b>		d=16
Top Strut Mounting	520 i 24V, 525 i, 525 i 24V, 530 i	07/1990 →; for government vehicles;	<b>F8-7440</b>		d=16
Top Strut Mounting	520 i, 525 td	; <b>MT</b> , <b>SP</b>	<b>F8-7440</b>		d=16
Top Strut Mounting	524 td, 525 i, 525 i 24V, 525 tds, 530 i, 535 i, M 3.6, M 3.6 CAT	07/1990 →;	<b>F8-7440</b>		d=16
Top Strut Mounting	530 i V8, 540 i V8	; <b>MT</b> , <b>SP</b> , <b>ST</b>	<b>F8-7440</b>		d=16
Top Strut Mounting	535 i	07/1990 →; ; ; ;	<b>F8-7440</b>		d=16
Top Strut Mounting	M 3.6, M 3.6 CAT	07/1990 →; ; ;	<b>F8-7440</b>		d=16
Protective Cap/Bellow, shock absorber	518 i, 520 i, 520 i 24V, 524 td, 525 i, 525 i 24V, 525 iX 24V, 525 td, 525 tds, 530 i, 530 i V8, 535 i, 540 i V8		<b>F8-7685</b>		H=91
Protective Cap/Bellow, shock absorber	518 i, 520 i 24V, 525 i 24V, 525 iX 24V, 525 tds, 535 i, M 3.8	09/1992 →; <b>SP</b>	<b>F8-7738</b>		H=200
Protective Cap/Bellow, shock absorber	518 i, 520 i, 520 i 24V, 524 td, 525 i, 525 i 24V, 525 iX 24V, 525 td, 525 tds, 530 i, 535 i, M 3.5, M 3.6 CAT, M 3.8	<b>AU</b> , <b>ME</b> ; <b>SP</b>	<b>F8-7738</b>		H=200
Protective Cap/Bellow, shock absorber	518 i, 520 i, 520 i 24V, 524 td, 525 i, 530 i, 535 i, M 3.6 CAT	07/1990 →;	<b>F8-7738</b>		H=200
Protective Cap/Bellow, shock absorber	518 i, 530 i V8	; <b>SP</b>	<b>F8-7738</b>		H=200
Protective Cap/Bellow, shock absorber	525 i 24V, 525 iX 24V, 525 td, 525 tds, 540 i V8, M 3.8		<b>F8-7738</b>		H=200
Protective Cap/Bellow, shock absorber	540 i V8	<b>SP</b>	<b>F8-7738</b>		H=200

<b>F8-7439</b>	<b>F8-7440</b>	<b>F8-7685</b>	<b>F8-7738</b>	<b>F8-7976</b>
Ref.Nr.: 31331133292	Ref.Nr.: 31331139437	Ref.Nr.: 1134314	Ref.Nr.: 31321125878	Ref.Nr.: 33551138104

**Article Description****Article Nr.****Fitting Position****5 (E34) 12/1987 → 09/1995**

Stabiliser Mounting	518 i, 524 td, 525 tds, 535 i	10/1991 →	<b>F8-7976</b>		D=17
Stabiliser Mounting	518 i, 525 td, 530 i, 530 i V8, 540 i V8		<b>F8-7976</b>		D=17
Stabiliser Mounting	520 i 24V, 525 i 24V	10/1991 →;  M 50	<b>F8-7976</b>		D=17
Stabiliser Mounting	525 iX 24V	M 50	<b>F8-7976</b>		D=17
Control Arm-/Trailing Arm Bush	518 i, 520 i, 520 i 24V, 524 td, 525 i, 525 i 24V, 525 iX 24V, 525 td, 525 tds, 530 i, 530 i V8, 535 i, 540 i V8, M 3.6 CAT, M 3.8		<b>G7-767</b>		L=50; Mounting points diam.[mm]=14,1
Control Arm-/Trailing Arm Bush	518 i, 520 i, 520 i 24V, 524 td, 525 i, 525 i 24V, 525 td, 525 tds, 530 i, 530 i V8, 535 i, 540 i V8, M 3.5, M 3.6, M 3.6 CAT, M 3.8		<b>G9-527</b>		H1=42; H2=52; d=12; D=46.5
Control Arm-/Trailing Arm Bush	518 i	for OE: 31121132159, 31121132160, 31121133711, 31121133712, 31121141097, 31121141098	<b>G9-687</b>		H1=47; H2=56; d=14; D=58
Control Arm-/Trailing Arm Bush	520 i, 520 i 24V, 525 i, 525 i 24V	Blue; for OE: 31121132159, 31121132160, 31121133711, 31121133712, 31121141097, 31121141098	<b>G9-688</b>		H1=48; H2=56; d=14; D=58
Control Arm-/Trailing Arm Bush	524 td, 525 td, 525 tds, 530 i, 530 i V8, 535 i, 540 i V8	beige/brown, White/Brown; for OE: 31121132159, 31121132160, 31121133711, 31121133712, 31121141097, 31121141098	<b>G9-689</b>		H1=48; H2=56; d=14; D=58
Bellow, steering	525 iX 24V	with clamps;	<b>LM-1001S</b>		d1=37; d2=51; L [mm]=185

**5 Touring (E34) 11/1991 → 01/1997**

Dust Cover Kit, shock absorber	518 g, 518 i, 520 i, 525 i, 525 td, 525 tds, 530 i V8, 540 i		<b>AK-735004</b>		
Bush, steering arm shaft	518 g, 518 i, 520 i, 525 i, 525 td, 525 tds, 530 i V8, 540 i, M 3.8		<b>F7-2039</b>		H=55; d=10; D1=27; D2=36
Stabiliser Mounting	518 g, 518 i, 520 i, 525 i, 525 td, 525 tds, 530 i V8, 540 i		<b>F8-5114</b>		H=60; d=23; D=51
Stabiliser Mounting	518 i, 520 i, 525 i, 525 td, 525 tds		<b>F8-5115</b>		H=60; d=24; D=51
Bellow, steering	525 ix		<b>F8-5171</b>		Total Br. Drum Height [mm]=185
Mounting, axle beam	518 g, 518 i, 520 i, 525 i, 525 ix, 525 td, 525 tds, 530 i V8, 540 i, M 3.8		<b>F8-5317</b>		d=15; D=80
Engine Mounting	530 i V8		<b>F8-5405</b>		
Top Strut Mounting	518 g, 518 i, 520 i, 525 i, 525 ix, 525 td, 525 tds, 530 i V8, 540 i		<b>F8-5416</b>		
Top Strut Mounting	518 i		<b>F8-5416</b>		
Top Strut Mounting	518 g, 518 i, 520 i, 525 td, 525 tds		<b>F8-5419</b>		Bolt Distance [mm]=87; d=14, 31; D=130
Engine Mounting	525 td, 525 tds		<b>F8-5431</b>		
Stabiliser Mounting	518 g, 518 i, 520 i, 525 i, 525 td, 525 tds, 530 i V8, 540 i		<b>F8-5689</b>		d=15; L=40; D=34
Stabiliser Mounting	518 i		<b>F8-5689</b>		d=15; L=40; D=34



Article Description



Article Nr.

Fitting Position



**5 Touring (E34)**

11/1991 → 01/1997

Rubber Buffer, suspension	518 g, 518 i, 520 i, 525 td		<b>F8-5690</b>		H=85
Mounting, transfer gear	525 i, 530 i V8, 540 i, M 3.8		<b>F8-5771</b>		
Control Arm-/Trailing Arm Bush	518 i, 525 i, 525 ix, 530 i V8, 540 i, M 3.8		<b>F8-5772</b>		H=60; d=12,5; D=51
Rubber Buffer, suspension	518 g, 518 i, 520 i, 525 td, 525 tds	for OE: 33531135624	<b>F8-5867</b>		H=99
Mounting, automatic transmission	525 td, 525 tds, M 3.8		<b>F8-6491</b>		H=34; D=36, 50; Outer Thread [mm]=M8 x 1,25mm
Engine Mounting	518 g, 518 i		<b>F8-6741</b>		
Joint, propshaft	525 ix		<b>F8-6763</b>		d=50; D=128; Thick./Strength 1 [mm]=39
Mounting, propshaft	518 i		<b>F8-6777</b>		d=30
Joint, propshaft	M 3.8		<b>F8-6783</b>		
Control Arm-/Trailing Arm Bush	518 g, 518 i, 520 i, 525 i, 525 ix, 525 td, 525 tds, 530 i V8, 540 i		<b>F8-7352</b>		d=12; L=67; D=44
Repair Kit, link	518 g, 518 i, 520 i, 525 i, 525 ix, 525 td, 525 tds, 530 i V8, 540 i		<b>F8-7352S</b>		d=12; L=67; D=44
Top Strut Mounting	525 ix		<b>F8-7425</b>		
Top Strut Mounting	520 i, 525 td		<b>F8-7440</b>		d=16
Top Strut Mounting	525 i, 525 tds, 530 i V8, 540 i		<b>F8-7440</b>		d=16
Protective Cap/Bellow, shock absorber	518 g, 518 i, 520 i, 525 i, 525 ix, 525 td, 525 tds, 530 i V8, 540 i		<b>F8-7685</b>		H=91
Protective Cap/Bellow, shock absorber	518 g, 518 i, 540 i		<b>F8-7738</b>		H=200
Protective Cap/Bellow, shock absorber	520 i, 525 i, 525 ix, 525 td, 525 tds, 530 i V8, M 3.8		<b>F8-7738</b>		H=200
Protective Cap/Bellow, shock absorber	520 i, 525 i, 525 ix, 525 td, 525 tds, 530 i V8, M 3.8		<b>F8-7738</b>		H=200
Protective Cap/Bellow, shock absorber	520 i, 525 i, 525 ix, 525 tds	09/1992 →;	<b>F8-7738</b>		H=200
Protective Cap/Bellow, shock absorber	525 td, 530 i V8		<b>F8-7738</b>		H=200
Stabiliser Mounting	518 g, 518 i, 525 i, 525 td, 525 tds, 530 i V8, 540 i		<b>F8-7976</b>		D=17
Stabiliser Mounting	520 i, 525 ix	M 50	<b>F8-7976</b>		D=17
Control Arm-/Trailing Arm Bush	518 g, 518 i, 520 i, 525 i, 525 ix, 525 td, 525 tds, 530 i V8, 540 i, M 3.8		<b>G7-767</b>		L=50; Mounting points diam.[mm]=14,1
Control Arm-/Trailing Arm Bush	518 g, 518 i, 520 i, 525 i, 525 td, 525 tds, 530 i V8, 540 i, M 3.8		<b>G9-527</b>		H1=42; H2=52; d=12; D=46.5
Control Arm-/Trailing Arm Bush	518 g, 518 i	for OE: 31121132159, 31121132160, 31121133711, 31121133712, 31121141097, 31121141098	<b>G9-687</b>		H1=47; H2=56; d=14; D=58

<b>F8-5690</b>	<b>F8-5771</b>	<b>F8-5772</b>	<b>F8-5867</b>	<b>F8-6491</b>	<b>F8-6741</b>	<b>F8-6763</b>
Ref.Nr.: 31331125215	Ref.Nr.: 33311132257	Ref.Nr.: 33171130874	Ref.Nr.: 33531135624	Ref.Nr.: 23 71 1 131 664	Ref.Nr.: 11811141526	Ref.Nr.: 26111227717
<b>F8-6777</b>	<b>F8-6783</b>	<b>F8-7352</b>	<b>F8-7352S</b>	<b>F8-7425</b>	<b>F8-7440</b>	<b>F8-7685</b>
Ref.Nr.: 26121229089	Ref.Nr.: 26112226527	Ref.Nr.: 33321123462	Ref.Nr.: 33321123462	Ref.Nr.: 3133-1139436	Ref.Nr.: 31331139437	Ref.Nr.: 1134314
<b>F8-7738</b>	<b>F8-7976</b>	<b>G7-767</b>	<b>G9-527</b>	<b>G9-687</b>	<b>G9-688</b>	
Ref.Nr.: 31321125878	Ref.Nr.: 33551138104	Ref.Nr.: 33321123463	Ref.Nr.: 31121124622	Ref.Nr.: 31121133710	Ref.Nr.: 31121136605	

**Article Description****Article Nr.****Fitting Position**

<b>5 Touring (E34)</b>			<b>11/1991 → 01/1997</b>		
Control Arm-/Trailing Arm Bush	520 i, 525 i	Blue; for OE: 31121132159, 31121132160, 31121133711, 31121133712, 31121141097, 31121141098	<b>G9-688</b>		H1=48; H2=56; d=14; D=58
Control Arm-/Trailing Arm Bush	525 td, 525 tds, 530 i V8, 540 i	beige/brown, White/Brown; for OE: 31121132159, 31121132160, 31121133711, 31121133712, 31121141097, 31121141098	<b>G9-689</b>		H1=48; H2=56; d=14; D=58
Bellow, steering	525 ix	with clamps;	<b>LM-10011S</b>		d1=37; d2=51; L [mm]=185
<b>5 (E39)</b>			<b>11/1995 → 06/2003</b>		
Dust Cover Kit, shock absorber	520 d, 520 i, 523 i, 525 d, 525 i, 525 td, 525 tds, 528 i, 530 d, 530 i, 535 i, 540 i		<b>AK-735136</b>		
Dust Cover Kit, shock absorber	520 d, 520 i, 523 i, 525 d, 525 i, 525 td, 525 tds, 528 i, 530 d, 530 i, 535 i, 540 i	<b>ST</b>	<b>AK-735447</b>		
Bush, steering arm shaft	535 i, 540 i, M 4.9		<b>F7-2039</b>		H=55; d=10; D1=27; D2=36
Anti-Friction Bearing	520 i, 523 i, 525 d, 525 td, 525 tds, 528 i, 530 d, 530 i, 535 i, 540 i, M 4.9		<b>F8-3063</b>		
Bearing, wheel bearing housing	All Models		<b>F8-5299</b>		H=67; H1=60; d=16; D=57; D1=52
Mounting, axle beam	M 4.9		<b>F8-5317</b>		d=15; D=80
Engine Mounting	520 i, 523 i, 528 i		<b>F8-5405</b>		
Engine Mounting	525 td, 525 tds		<b>F8-5424</b>		
Engine Mounting	535 i		<b>F8-5425</b>		
Engine Mounting	540 i		<b>F8-5425</b>		
Engine Mounting	M 4.9		<b>F8-5425</b>		
Engine Mounting	535 i		<b>F8-5426</b>		
Engine Mounting	540 i		<b>F8-5426</b>		
Engine Mounting	M 4.9		<b>F8-5426</b>		
Top Strut Mounting	520 d, 520 i, 525 d, 525 i, 530 d, 530 i		<b>F8-5433</b>		
Top Strut Mounting	520 i, 523 i, 525 td, 525 tds, 528 i	09/1997 →;	<b>F8-5433</b>		
Belt Pulley, crankshaft	520 i		<b>F8-5661</b>		
Belt Pulley, crankshaft	525 i, 530 i	09/2002 →	<b>F8-5661</b>		
Belt Pulley, crankshaft	520 i, 523 i, 528 i	09/1998 →	<b>F8-5662</b>		
Belt Pulley, crankshaft	520 i, 525 i, 530 i		<b>F8-5662</b>		
Rubber Buffer, suspension	520 i, 523 i, 525 td, 525 tds, 528 i, 535 i, 540 i		<b>F8-5690</b>		H=85
Top Strut Mounting	535 i, 540 i	<b>MT</b>	<b>F8-5774</b>		
Top Strut Mounting	M 4.9		<b>F8-5774</b>		
Top Strut Mounting	520 d, 520 i, 523 i, 525 d, 525 i, 525 td, 525 tds, 528 i, 530 d, 530 i, 535 i, 540 i		<b>F8-5775</b>		

<b>AK-735136</b>	<b>AK-735447</b>	<b>F7-2039</b>	<b>F8-3063</b>	<b>F8-5299</b>	<b>F8-5317</b>	<b>F8-5405</b>
Ref.Nr.: 31331091868	Ref.Nr.: 33531091031	Ref.Nr.: 32211136452	Ref.Nr.: 1090612	Ref.Nr.: 33321090504	Ref.Nr.: 33311128670	Ref.Nr.: 22111097267
<b>F8-5424</b>	<b>F8-5425</b>	<b>F8-5426</b>	<b>F8-5433</b>	<b>F8-5661</b>	<b>F8-5662</b>	<b>F8-5690</b>
Ref.Nr.: 22111094248	Ref.Nr.: 22111092824	Ref.Nr.: 22111092823	Ref.Nr.: 31331094616	Ref.Nr.: 11237513862	Ref.Nr.: 1 438 995	Ref.Nr.: 31331125215
<b>F8-5774</b>	<b>F8-5775</b>	<b>F8-5866</b>	<b>G9-688</b>	<b>G9-689</b>	<b>LM-10011S</b>	
Ref.Nr.: 33521091238	Ref.Nr.: 33521091710	Ref.Nr.: 33521091711	Ref.Nr.: 31121136605	Ref.Nr.: 31121139456	Ref.Nr.: 31111137070	

**Article Description**

**Article Nr.**
**Fitting Position**

**5 (E39)**
**11/1995 → 06/2003**

Top Strut Mounting	528 i, 530 d, 530 i, 535 i, 540 i		<b>F8-5866</b>		
Rubber Buffer, suspension	520 d, 520 i, 523 i, 525 d, 525 i, 525 td, 525 tds, 528 i, 530 d, 530 i, M 4.9		<b>F8-5869</b>		H=90
Mounting, axle beam	520 d, 520 i, 523 i, 525 d, 525 i, 525 td, 525 tds, 528 i, 530 d, 530 i, 535 i, 540 i, M 4.9		<b>F8-5887</b>		H1=58; H2=42; D=69
Top Strut Mounting	520 d, 525 d, 528 i, 530 d, 530 i, 535 i, 540 i, M 4.9, M 5.0		<b>F8-5923</b>		
Rubber Buffer, suspension	520 i, 523 i, 525 d, 525 i, 525 td, 525 tds, 528 i, 530 d, 530 i, 535 i, 540 i	for OE: 33531091031; <b>ST</b>	<b>F8-6087</b>		L=90
Top Strut Mounting	520 i, 523 i, 525 td, 525 tds, 528 i		<b>F8-6413</b>		
Mounting, automatic transmission	520 i	M52 (20 6 S3)	<b>F8-6491</b>		H=34; D=36, 50; Outer Thread [mm]=M8 x 1,25mm
Mounting, automatic transmission	520 i, 523 i, 525 d, 525 i, 525 td, 525 tds, 528 i, 530 d, 530 i, 540 i, M 4.9		<b>F8-6491</b>		H=34; D=36, 50; Outer Thread [mm]=M8 x 1,25mm
Mounting, automatic transmission	535 i	M62 B (35 8 S1)	<b>F8-6491</b>		H=34; D=36, 50; Outer Thread [mm]=M8 x 1,25mm
Mounting, automatic transmission	535 i	M62 B (35 8 S2)	<b>F8-6491</b>		H=34; D=36, 50; Outer Thread [mm]=M8 x 1,25mm
Engine Mounting	525 d, 530 d	Paired article nr: F8-7879	<b>F8-6499</b>		
Mounting, axle beam	520 d, 520 i, 523 i, 525 d, 525 i, 525 td, 525 tds, 528 i, 530 d, 530 i, 535 i, 540 i, M 4.9		<b>F8-6583</b>		
Joint, propshaft	523 i, 525 i	09/1996 →;	<b>F8-6762</b>		d=38; D=106; Thick./Strength 1 [mm]=31
Joint, propshaft	535 i		<b>F8-6763</b>		d=50; D=128; Thick./Strength 1 [mm]=39
Mounting, propshaft	520 i, 523 i, 525 i, 525 td, 525 tds, 528 i, 530 i		<b>F8-6777</b>		d=30
Mounting, propshaft	520 i, 525 td, 525 tds, 528 i		<b>F8-6778</b>		
Mounting, propshaft	523 i	01/1996 →;	<b>F8-6778</b>		
Mounting, propshaft	520 d, 520 i, 523 i, 525 i, 525 td, 528 i, 530 i		<b>F8-6779</b>		
Mounting, propshaft	520 i, 525 tds		<b>F8-6779</b>		
Mounting, propshaft	525 tds		<b>F8-6779</b>		
Mounting, propshaft	520 d, 525 tds, 530 i		<b>F8-6780</b>		
Mounting, propshaft	520 i, 525 tds, 528 i		<b>F8-6780</b>		
Mounting, propshaft	523 i, 525 td, 528 i		<b>F8-6780</b>		
Top Strut Mounting	535 i, 540 i	<b>MT</b> , <b>SP</b>	<b>F8-6781</b>		
Top Strut Mounting	M 4.9		<b>F8-6781</b>		
Top Strut Mounting	520 d, 520 i, 523 i, 525 d, 525 i, 525 td, 525 tds, 528 i, 530 d, 530 i, 535 i, 540 i		<b>F8-6782</b>		
Stabiliser Mounting	520 i, 523 i, 525 i, 528 i, 530 i		<b>F8-7144</b>		d=22.5
Stabiliser Mounting	525 d		<b>F8-7144</b>		d=22.5

<b>F8-5866</b>	<b>F8-5869</b>	<b>F8-5887</b>	<b>F8-5923</b>	<b>F8-6087</b>	<b>F8-6413</b>	<b>F8-6491</b>
Ref.Nr.: 33521091711	Ref.Nr.: 31331140140	Ref.Nr.: 33171093008	Ref.Nr.: 31331091708	Ref.Nr.: 33531091031	Ref.Nr.: 31331091709	Ref.Nr.: 23 71 1 131 664
<b>F8-6499</b>	<b>F8-6583</b>	<b>F8-6762</b>	<b>F8-6763</b>	<b>F8-6777</b>	<b>F8-6778</b>	<b>F8-6779</b>
Ref.Nr.: 22111097153	Ref.Nr.: 33311094036	Ref.Nr.: 26111227869	Ref.Nr.: 26111227717	Ref.Nr.: 26121229089	Ref.Nr.: 26121229089-PA	Ref.Nr.: 26121229242
<b>F8-6780</b>	<b>F8-6781</b>	<b>F8-6782</b>	<b>F8-7144</b>	<b>F8-7353</b>		
Ref.Nr.: 26121229242	Ref.Nr.: 33522229854	Ref.Nr.: 33501094977	Ref.Nr.: 31351093108	Ref.Nr.: 33321090504		



**Article Description****Article Nr.****Fitting Position**

<b>5 (E39)</b>			<b>11/1995 → 06/2003</b>		
Bearing, wheel bearing housing	All Models	with lock ring	<b>F8-7353</b>		H=67; H1=60; d=16; D=57; D1=52
Control Arm-/Trailing Arm Bush	520 d, 520 i, 523 i, 525 d, 525 i, 525 td, 525 tds, 528 i, 530 d, 530 i, 535 i, 540 i, M 4.9		<b>F8-7602</b>		H=40; d=10; D=48
Rubber Buffer, suspension	520 d, 520 i, 523 i, 525 d, 525 i, 525 td, 525 tds, 528 i, 530 d, 530 i, 535 i, 540 i	<b>MT, SP</b>	<b>F8-7726</b>		
Protective Cap/Bellow, shock absorber	520 d, 520 i, 523 i, 525 d, 525 i, 525 td, 525 tds, 528 i, 530 d, 530 i, 535 i, 540 i	<b>ST</b>	<b>F8-7727</b>		H=86
Protective Cap/Bellow, shock absorber	520 d, 520 i, 523 i, 525 d, 525 i, 525 td, 525 tds, 528 i, 530 d, 530 i		<b>F8-7731</b>		
Engine Mounting	525 d, 530 d	Paired article nr: F8-6499	<b>F8-7879</b>		
Stabiliser Mounting	520 d, 520 i, 523 i, 525 d, 525 i, 525 td, 525 tds, 528 i, 530 d, 530 i, 535 i, 540 i		<b>F8-7939</b>		
Engine Mounting	520 i, 523 i, 525 i, 528 i, 530 i		<b>F8-8174</b>		
Engine Mounting	520 d		<b>F8-8181</b>		
Engine Mounting	520 d		<b>F8-8182</b>		
Control Arm-/Trailing Arm Bush	520 d, 520 i, 523 i, 525 d, 525 i, 525 td, 525 tds, 528 i, 530 d, 530 i		<b>G9-658</b>		H1=68; H2=60; d=12; D=58
Control Arm-/Trailing Arm Bush	520 d, 520 i, 523 i, 525 d, 525 i, 525 td, 525 tds, 528 i, 530 d, 530 i		<b>G9-658S</b>		H1=68; H2=60; d=12; D=58
Bellow, steering	520 d, 520 i, 523 i, 525 d, 525 i, 525 td, 525 tds, 528 i, 530 d, 530 i	with clamps;	<b>LM-10012S</b>		d1=39; d2=52; L [mm]=175
<b>5 Touring (E39)</b>			<b>01/1997 → 05/2004</b>		
Dust Cover Kit, shock absorber	All Models		<b>AK-735136</b>		
Dust Cover Kit, shock absorber	All Models	<b>ST</b>	<b>AK-735448</b>		
Anti-Friction Bearing	520 i, 523 i, 525 tds, 528 i, 530 d, 530 i, 540 i		<b>F8-3063</b>		
Bearing, wheel bearing housing	All Models		<b>F8-5299</b>		H=67; H1=60; d=16; D=57; D1=52
Engine Mounting	520 i, 523 i, 528 i		<b>F8-5405</b>		
Engine Mounting	525 tds		<b>F8-5424</b>		
Engine Mounting	540 i		<b>F8-5425</b>		
Engine Mounting	540 i		<b>F8-5426</b>		
Top Strut Mounting	520 d, 520 i, 525 d, 525 i, 530 d, 530 i		<b>F8-5433</b>		
Top Strut Mounting	520 i, 523 i, 528 i	09/1997 →;	<b>F8-5433</b>		
Top Strut Mounting	525 tds	06/1998 →;	<b>F8-5433</b>		
Belt Pulley, crankshaft	520 i		<b>F8-5661</b>		
Belt Pulley, crankshaft	525 i, 530 i	09/2002 →	<b>F8-5661</b>		
Belt Pulley, crankshaft	520 i, 523 i, 528 i	09/1998 →	<b>F8-5662</b>		
Belt Pulley, crankshaft	520 i, 525 i, 530 i		<b>F8-5662</b>		

<b>AK-735136</b>	<b>AK-735448</b>	<b>F8-3063</b>	<b>F8-5299</b>	<b>F8-5405</b>	<b>F8-5424</b>	<b>F8-5425</b>
Ref.Nr.: 31331091868	Ref.Nr.: 33521092943	Ref.Nr.: 1090612	Ref.Nr.: 33321090504	Ref.Nr.: 22111097267	Ref.Nr.: 22111094248	Ref.Nr.: 22111092824
<b>F8-5426</b>	<b>F8-5433</b>	<b>F8-5661</b>	<b>F8-5662</b>	<b>F8-5690</b>	<b>F8-7353</b>	<b>F8-7602</b>
Ref.Nr.: 22111092823	Ref.Nr.: 31331094616	Ref.Nr.: 11237513862	Ref.Nr.: 1 438 995	Ref.Nr.: 31331125215	Ref.Nr.: 33321090504	Ref.Nr.: 33321097264
<b>F8-7726</b>	<b>F8-7727</b>	<b>F8-7731</b>	<b>F8-7879</b>	<b>F8-7939</b>	<b>F8-8174</b>	<b>F8-8181</b>
Ref.Nr.: 33531093094	Ref.Nr.: 31331137932	Ref.Nr.: 37121129716	Ref.Nr.: 9266153	Ref.Nr.: 33551093663	Ref.Nr.: 23711137817	Ref.Nr.: 22116752741

Article Description



Article Nr.

Fitting Position



**5 Touring (E39)**

01/1997 → 05/2004

Rubber Buffer, suspension	520 d, 520 i, 525 d, 525 i, 525 tds, 530 d, 530 i		<b>F8-5690</b>		H=85
Mounting, axle beam	All Models		<b>F8-5887</b>		H1=58; H2=42; D=69
Top Strut Mounting	528 i, 530 d, 530 i, 540 i		<b>F8-5923</b>		
Top Strut Mounting	All Models		<b>F8-5930</b>		
Top Strut Mounting	520 i, 523 i, 525 tds, 528 i		<b>F8-6413</b>		
Mounting, automatic transmission	520 i	M52 (20 6 S4)	<b>F8-6491</b>		H=34; D=36, 50; Outer Thread [mm]=M8 x 1,25mm
Mounting, automatic transmission	520 i, 523 i, 525 d, 525 i, 525 tds, 528 i, 530 d, 530 i, 540 i		<b>F8-6491</b>		H=34; D=36, 50; Outer Thread [mm]=M8 x 1,25mm
Engine Mounting	525 d, 530 d	Paired article nr: F8-7879	<b>F8-6499</b>		
Mounting, axle beam	All Models		<b>F8-6583</b>		
Mounting, propshaft	520 i, 523 i, 525 i, 525 tds, 528 i, 530 i		<b>F8-6777</b>		d=30
Mounting, propshaft	520 i, 523 i, 525 tds, 528 i		<b>F8-6778</b>		
Mounting, propshaft	520 d, 520 i, 525 i, 528 i, 530 i		<b>F8-6779</b>		
Mounting, propshaft	520 i, 523 i, 525 tds		<b>F8-6779</b>		
Mounting, propshaft	523 i, 525 tds		<b>F8-6779</b>		
Mounting, propshaft	520 d, 523 i, 530 i		<b>F8-6780</b>		
Mounting, propshaft	520 i, 523 i, 525 tds		<b>F8-6780</b>		
Mounting, propshaft	528 i		<b>F8-6780</b>		
Stabiliser Mounting	520 d		<b>F8-7144</b>		d=22.5
Stabiliser Mounting	520 i, 523 i, 525 i, 528 i		<b>F8-7144</b>		d=22.5
Stabiliser Mounting	530 i		<b>F8-7144</b>		d=22.5
Bearing, wheel bearing housing	All Models	with lock ring	<b>F8-7353</b>		H=67; H1=60; d=16; D=57; D1=52
Control Arm-/Trailing Arm Bush	All Models		<b>F8-7602</b>		H=40; d=10; D=48
Protective Cap/Bellow, shock absorber	All Models		<b>F8-7728</b>		
Rubber Buffer, suspension	520 d, 520 i, 523 i, 525 d, 525 i, 525 tds, 528 i, 530 d, 530 i		<b>F8-7729</b>		
Rubber Buffer, suspension	520 d, 520 i, 523 i, 525 d, 525 i, 525 tds, 528 i, 530 d, 530 i		<b>F8-7730</b>		
Engine Mounting	525 d, 530 d	Paired article nr: F8-6499	<b>F8-7879</b>		
Stabiliser Mounting	520 d, 520 i, 523 i, 525 d, 525 i, 525 tds, 528 i, 530 d, 530 i		<b>F8-7939</b>		
Engine Mounting	520 i, 523 i, 525 i, 528 i, 530 i		<b>F8-8174</b>		
Engine Mounting	520 d		<b>F8-8181</b>		
Engine Mounting	520 d		<b>F8-8182</b>		

<b>F8-5690</b>	<b>F8-5887</b>	<b>F8-5923</b>	<b>F8-5930</b>	<b>F8-6413</b>	<b>F8-6491</b>	<b>F8-6499</b>
Ref.Nr.: 31331125215	Ref.Nr.: 33171093008	Ref.Nr.: 31331091708	Ref.Nr.: 33521093416	Ref.Nr.: 31331091709	Ref.Nr.: 23 71 1 131 664	Ref.Nr.: 22111097153
<b>F8-6583</b>	<b>F8-6777</b>	<b>F8-6778</b>	<b>F8-6779</b>	<b>F8-6780</b>	<b>F8-7144</b>	<b>F8-7353</b>
Ref.Nr.: 33311094036	Ref.Nr.: 26121229089	Ref.Nr.: 26121229089-PA	Ref.Nr.: 26121229242	Ref.Nr.: 26121229242	Ref.Nr.: 31351093108	Ref.Nr.: 33321090504
<b>F8-7602</b>	<b>F8-7728</b>	<b>F8-7729</b>	<b>F8-7730</b>	<b>F8-7879</b>	<b>F8-7939</b>	<b>F8-8174</b>
Ref.Nr.: 33321097264	Ref.Nr.: 33521092943	Ref.Nr.: 33531094724	Ref.Nr.: 33531094065	Ref.Nr.: 9266153	Ref.Nr.: 33551093663	Ref.Nr.: 23711137817

**Article Description****Article Nr.****Fitting Position**

<b>5 Touring (E39)</b>				<b>01/1997 → 05/2004</b>	
Control Arm-/Trailing Arm Bush	520 d, 520 i, 523 i, 525 d, 525 i, 528 i, 530 d, 530 i		<b>G9-658</b>		H1=68; H2=60; d=12; D=58
Control Arm-/Trailing Arm Bush	525 tds	06/1998 →	<b>G9-658</b>		H1=68; H2=60; d=12; D=58
Control Arm-/Trailing Arm Bush	520 d, 520 i, 523 i, 525 d, 525 i, 525 tds, 528 i, 530 d, 530 i		<b>G9-658S</b>		H1=68; H2=60; d=12; D=58
Bellow, steering	520 d, 520 i, 523 i, 525 d, 525 i, 525 tds, 528 i, 530 d, 530 i	with clamps;	<b>LM-10012S</b>		d1=39; d2=52; L [mm]=175
<b>5 (E60)</b>				<b>07/2003 → 03/2010</b>	
Dust Cover Kit, shock absorber	520 d, 520 i, 523 i, 525 d, 525 d xDrive, 525 i, 525 i xDrive, 525 xd, 525 xi, 530 d, 530 d xDrive, 530 i, 530 i xDrive, 530 xd, 530 xi, 535 d, 540 i, 545 i, 550 i	<b>ST</b>	<b>AK-735174</b>		
Dust Cover Kit, shock absorber	520 d, 520 i, 523 i, 525 d, 525 i, 530 d, 530 i, 535 d, 540 i, 545 i, 550 i	<b>ST</b>	<b>AK-735428</b>		
Dust Cover Kit, shock absorber	525 xi, 530 xd, 530 xi	<b>ST</b>	<b>AK-735429</b>		
Dust Cover Kit, shock absorber	525 d xDrive, 525 i xDrive, 525 xd, 525 xi, 530 d xDrive, 530 i xDrive, 530 xd, 530 xi	<b>ST</b>	<b>AK-735430</b>		
Dust Cover Kit, shock absorber	525 xi, 530 xd, 530 xi	03/2006 →; <b>ST</b>	<b>AK-735430</b>		
Alternator Freewheel Clutch	523 i, 525 i, 525 i xDrive, 525 xi, 530 i, 530 i xDrive, 530 xi		<b>F5-1053</b>		
Anti-Friction Bearing	M		<b>F8-3063</b>		
Bearing, wheel bearing housing	520 d, 520 i, 523 i, 525 d, 525 d xDrive, 525 i, 525 i xDrive, 525 xd, 525 xi, 530 d, 530 d xDrive, 530 i, 530 i xDrive, 530 xd, 530 xi, 535 d, 540 i, 545 i, 550 i, M		<b>F8-5299</b>		H=67; H1=60; d=16; D=57; D1=52
Top Strut Mounting	520 d, 520 i, 523 i, 525 d, 525 d xDrive, 525 i, 525 i xDrive, 525 xd, 525 xi, 530 d, 530 d xDrive, 530 i, 530 i xDrive, 530 xd, 530 xi, 535 d, 540 i, 545 i, 550 i		<b>F8-5433</b>		
Belt Pulley, crankshaft	520 i, 525 i, 530 i		<b>F8-5661</b>		
Protective Cap/Bellow, shock absorber	520 d, 520 i, 523 i, 525 d, 525 d xDrive, 525 i, 525 i xDrive, 525 xd, 525 xi, 530 d, 530 d xDrive, 530 i, 530 i xDrive, 530 xd, 530 xi, 535 d, 540 i, 545 i, 550 i, M	Universal	<b>F8-6545</b>		H=140
Joint, propshaft	525 d, 530 d, 535 d, 540 i, 545 i, 550 i		<b>F8-6764</b>		d=44.5; D=155; Thick./Strength 1 [mm]=30
Joint, propshaft	520 d, 520 i, 523 i, 525 i, 530 i		<b>F8-6767</b>		
Control Arm-/Trailing Arm Bush	520 d, 520 i, 523 i, 525 d, 525 i, 530 d, 530 i, 535 d, 540 i, 545 i, 550 i, M		<b>F8-6774</b>		H=76; d=12.2; D=69.9
Mounting, automatic transmission	520 d		<b>F8-7034</b>		
Mounting, automatic transmission	540 i, 545 i, 550 i		<b>F8-7036</b>		
Mounting, automatic transmission	525 d, 530 d, 535 d		<b>F8-7038</b>		
Mounting, automatic transmission	520 i, 523 i, 525 i, 530 i		<b>F8-7040</b>		

<b>AK-735174</b>	<b>AK-735428</b>	<b>AK-735429</b>	<b>AK-735430</b>	<b>F5-1053</b>	<b>F8-3063</b>	<b>F8-5299</b>
Ref.Nr.: 33536761027	Ref.Nr.: 31336764085	Ref.Nr.: 31304038214	Ref.Nr.: 31306774699	Ref.Nr.: 12314466273	Ref.Nr.: 1090612	Ref.Nr.: 33321090504
<b>F8-5433</b>	<b>F8-5661</b>	<b>F8-6545</b>	<b>F8-6764</b>	<b>F8-6767</b>	<b>F8-6774</b>	<b>F8-7034</b>
Ref.Nr.: 31331094616	Ref.Nr.: 11237513862	Ref.Nr.: 0146239	Ref.Nr.: 26117542238	Ref.Nr.: 26117522027	Ref.Nr.: 31120305612	Ref.Nr.: 22316769848
<b>F8-7036</b>	<b>F8-7038</b>	<b>F8-7040</b>	<b>F8-7050</b>	<b>G9-658</b>	<b>G9-658S</b>	<b>LM-10012S</b>
Ref.Nr.: 22316773825	Ref.Nr.: 22316761094	Ref.Nr.: 22316771741	Ref.Nr.: 22312283285	Ref.Nr.: 31129068753	Ref.Nr.: 31129068753	Ref.Nr.: 32131092876

**Article Description**

**Article Nr.**
**Fitting Position**

<b>5 (E60)</b>		<b>07/2003 → 03/2010</b>	
Mounting, manual transmission	M		<b>F8-7050</b>
Rubber Buffer, suspension	520 d, 520 i, 523 i, 525 d, 525 i, 530 d, 530 i, 535 d, 540 i, 545 i, 550 i	<b>ST</b>	<b>F8-7334</b>
Rubber Buffer, suspension	520 d, 520 i, 523 i, 525 d, 525 d xDrive, 525 i, 525 i xDrive, 525 xd, 525 xi, 530 d, 530 d xDrive, 530 i, 530 i xDrive, 530 xd, 530 xi, 535 d, 540 i, 545 i, 550 i	<b>ST</b>	<b>F8-7335</b>
Protective Cap/Bellow, shock absorber	520 d, 520 i, 523 i, 525 d, 525 d xDrive, 525 i, 525 i xDrive, 525 xd, 525 xi, 530 d, 530 d xDrive, 530 i, 530 i xDrive, 530 xd, 530 xi, 535 d, 540 i, 545 i, 550 i, M	Available as universal article: F8-6545	<b>F8-7336</b>
Bearing, wheel bearing housing	520 d, 520 i, 523 i, 525 d, 525 d xDrive, 525 i, 525 i xDrive, 525 xd, 525 xi, 530 d, 530 d xDrive, 530 i, 530 i xDrive, 530 xd, 530 xi, 535 d, 540 i, 545 i, 550 i, M	with lock ring	<b>F8-7353</b>
Top Strut Mounting	520 d, 520 i, 523 i, 525 d, 525 d, 525 d xDrive, 525 xi, 530 d, 530 i, 530 xd, 530 xi, 535 d, 540 i, 545 i, 550 i		<b>F8-7604</b>
Belt Pulley, crankshaft	525 d, 530 d, 530 xd, 535 d	Number of Ribs: 3, 5; Parameter: 6PK + 4PK	<b>F8-7641</b>
Stabiliser Mounting	520 d, 520 i, 523 i, 525 d, 525 i, 525 d xDrive, 525 xi, 530 d, 530 i, 530 xd, 530 xi, 535 d, 540 i, 545 i, 550 i, M		<b>F8-7917</b>
Engine Mounting	525 xd, 525 xi, 530 xd, 530 xi		<b>F8-8163</b>
Engine Mounting	520 i, 523 i, 525 i, 530 i		<b>F8-8201</b>
Control Arm-/Trailing Arm Bush	520 d, 520 i, 520i, 523 i, 525 d, 525 i, 525 xd, 525 xi, 530 d, 530 i, 530 xd, 530 xi, 535 d, 540 i, 545 i, 550 i, M		<b>G9-527</b>
Bellow, steering	520 d, 520 i, 523 i, 525 d, 525 d xDrive, 525 i, 525 i xDrive, 525 xd, 525 xi, 530 d, 530 d xDrive, 530 i, 530 i xDrive, 530 xd, 530 xi, 535 d, 540 i, 545 i, 550 i, M	with clamps	<b>LM-10100S</b>
Bellow, steering	525 xi, 530 xd, 530 xi	04/2006 →; with clamps	<b>LM-10100S</b>
<b>5 Touring (E61)</b>		<b>06/2004 → 12/2010</b>	
Dust Cover Kit, shock absorber	520 d, 523 i, 525 d, 525 i, 525 xi, 530 d, 530 i, 530 xd, 530 xi, 535 d, 545 i, 550 i, M		<b>AK-735173</b>
Dust Cover Kit, shock absorber	520 d, 520 i, 523 i, 525 d, 525 i, 530 d, 530 i, 535 d, 545 i, 550 i	<b>ST</b>	<b>AK-735428</b>
Dust Cover Kit, shock absorber	525 xi, 530 xd, 530 xi	<b>ST</b>	<b>AK-735429</b>
Dust Cover Kit, shock absorber	525 d xDrive, 525 i xDrive, 525 xd, 525 xi, 530 d xDrive, 530 i xDrive, 530 xd, 530 xi	<b>ST</b>	<b>AK-735430</b>
Dust Cover Kit, shock absorber	525 xi, 530 xd, 530 xi	03/2006 →; <b>ST</b>	<b>AK-735430</b>
Alternator Freewheel Clutch	523 i, 525 i, 525 i xDrive, 525 xi, 530 i, 530 i xDrive, 530 xi		<b>F5-1053</b>
Anti-Friction Bearing	M		<b>F8-3063</b>
Bearing, wheel bearing housing	520 d, 520 i, 523 i, 525 d, 525 d xDrive, 525 i, 525 i xDrive, 525 xd, 525 xi, 530 d, 530 d xDrive, 530 i, 530 i xDrive, 530 xd, 530 xi, 535 d, 545 i, 550 i, M		<b>F8-5299</b>

<b>AK-735173</b>	<b>AK-735428</b>	<b>AK-735429</b>	<b>AK-735430</b>	<b>F5-1053</b>	<b>F8-3063</b>	<b>F8-5299</b>
Ref.Nr.: 33526764268	Ref.Nr.: 31336764085	Ref.Nr.: 31304038214	Ref.Nr.: 31306774699	Ref.Nr.: 12314466273	Ref.Nr.: 1090612	Ref.Nr.: 33321090504
<b>F8-5433</b>	<b>F8-7050</b>	<b>F8-7334</b>	<b>F8-7335</b>	<b>F8-7336</b>	<b>F8-7353</b>	<b>F8-7604</b>
Ref.Nr.: 31331094616	Ref.Nr.: 22312283285	Ref.Nr.: 31336764085	Ref.Nr.: 33536761027	Ref.Nr.: 31331094749	Ref.Nr.: 33321090504	Ref.Nr.: 33526753810
<b>F8-7641</b>	<b>F8-7917</b>	<b>F8-8163</b>	<b>F8-8201</b>	<b>G9-527</b>	<b>LM-10100S</b>	
Ref.Nr.: 11237793593	Ref.Nr.: 31356761591	Ref.Nr.: 22316750858	Ref.Nr.: 22116761090	Ref.Nr.: 31121124622	Ref.Nr.: 32106765782	

**Article Description****Article Nr.****Fitting Position****5 Touring (E61)****06/2004 → 12/2010**

Top Strut Mounting	520 d, 520 i, 523 i, 525 d, 525 d xDrive, 525 i, 525 i xDrive, 525 xd, 525 xi, 530 d, 530 d xDrive, 530 i, 530 i xDrive, 530 xd, 530 xi, 535 d, 545 i, 550 i		<b>F8-5433</b>		
Belt Pulley, crankshaft	525 i		<b>F8-5661</b>		
Protective Cap/Bellow, shock absorber	520 d, 520 i, 523 i, 525 d, 525 d xDrive, 525 i, 525 i xDrive, 525 xd, 525 xi, 530 d, 530 d xDrive, 530 i, 530 i xDrive, 530 xd, 530 xi, 535 d, 545 i, 550 i, M	Universal	<b>F8-6545</b>		H=140
Joint, propshaft	525 d, 530 d, 535 d, 545 i, 550 i		<b>F8-6764</b>		d=44.5; D=155; Thick./Strength 1 [mm]=30
Joint, propshaft	520 d, 520 i, 523 i, 525 i, 530 i		<b>F8-6767</b>		
Control Arm-/Trailing Arm Bush	520 d, 520 i, 523 i, 525 d, 525 i, 530 d, 530 i, 535 d, 545 i, 550 i, M		<b>F8-6774</b>		H=76; d=12.2; D=69.9
Mounting, automatic transmission	520 d		<b>F8-7034</b>		
Mounting, automatic transmission	545 i, 550 i		<b>F8-7036</b>		
Mounting, automatic transmission	525 d, 530 d, 535 d		<b>F8-7038</b>		
Mounting, automatic transmission	523 i, 525 i, 530 i		<b>F8-7040</b>		
Rubber Buffer, suspension	520 d, 520 i, 523 i, 525 d, 525 i, 530 d, 530 i, 535 d, 545 i, 550 i	<b>ST</b>	<b>F8-7334</b>		H=85
Protective Cap/Bellow, shock absorber	520 d, 520 i, 523 i, 525 d, 525 d xDrive, 525 i, 525 i xDrive, 525 xd, 525 xi, 530 d, 530 d xDrive, 530 i, 530 i xDrive, 530 xd, 530 xi, 535 d, 545 i, 550 i, M	Available as universal article: F8-6545	<b>F8-7336</b>		H=136
Bearing, wheel bearing housing	520 d, 520 i, 523 i, 525 d, 525 d xDrive, 525 i, 525 i xDrive, 525 xd, 525 xi, 530 d, 530 d xDrive, 530 i, 530 i xDrive, 530 xd, 530 xi, 535 d, 545 i, 550 i, M	with lock ring	<b>F8-7353</b>		H=67; H1=60; d=16; D=57; D1=52
Belt Pulley, crankshaft	525 d, 525 xd, 530 d, 530 xd, 535 d	Number of Ribs: 3, 5; Parameter: 6PK + 4PK	<b>F8-7641</b>		
Stabiliser Mounting	520 d, 520 i, 523 i, 525 d, 525 i, 525 xd, 525 xi, 530 d, 530 i, 530 xd, 530 xi, 535 d, 545 i, 550 i, M		<b>F8-7917</b>		d=24,6
Engine Mounting	523 i, 525 i, 530 i		<b>F8-8201</b>		
Control Arm-/Trailing Arm Bush	520 d, 520 i, 520i, 523 i, 525 d, 525 i, 525 xd, 525 xi, 530 d, 530 i, 530 xd, 530 xi, 535 d, 545 i, 550 i, M		<b>G9-527</b>		H1=42; H2=52; d=12; D=46.5
Bellow, steering	520 d, 520 i, 523 i, 525 d, 525 i, 525 xd, 525 xi, 530 d, 530 i, 530 xd, 530 xi, 535 d, 545 i, 550 i, M	with clamps	<b>LM-10100S</b>		d1=15.5; d2=66; L [mm]=195
Bellow, steering	525 xi, 530 xd, 530 xi	04/2006 →; with clamps	<b>LM-10100S</b>		d1=15.5; d2=66; L [mm]=195

**5 (F10, F18)****12/2009 →**

Mounting, automatic transmission	525 d, 530 d, 535 d, 535 i, ActiveHybrid		<b>F8-7038</b>		
Bellow, steering	530 d xDrive, 535 d xDrive, 535 i xDrive, 550 i xDrive, M, M 550 d xDrive	with clamps	<b>LM-10100S</b>		d1=15.5; d2=66; L [mm]=195

<b>F8-5433</b>	<b>F8-5661</b>	<b>F8-6545</b>	<b>F8-6764</b>	<b>F8-6767</b>	<b>F8-6774</b>	<b>F8-7034</b>
Ref.Nr.: 31331094616	Ref.Nr.: 11237513862	Ref.Nr.: 0146239	Ref.Nr.: 26117542238	Ref.Nr.: 26117522027	Ref.Nr.: 31120305612	Ref.Nr.: 22316769848
<b>F8-7036</b>	<b>F8-7038</b>	<b>F8-7040</b>	<b>F8-7334</b>	<b>F8-7336</b>	<b>F8-7353</b>	<b>F8-7641</b>
Ref.Nr.: 22316773825	Ref.Nr.: 22316761094	Ref.Nr.: 22316771741	Ref.Nr.: 31336764085	Ref.Nr.: 31331094749	Ref.Nr.: 33321090504	Ref.Nr.: 11237793593
<b>F8-7917</b>	<b>F8-8201</b>	<b>G9-527</b>	<b>LM-10100S</b>			
Ref.Nr.: 31356761591	Ref.Nr.: 22116761090	Ref.Nr.: 31121124622	Ref.Nr.: 32106765782			

Article Description



Article Nr.

Fitting Position



### 5 Touring (F11)

09/2010 →

Mounting, automatic transmission	525 d, 530 d, 535 d, 535 i		<b>F8-7038</b>		
Bellow, steering	530 d xDrive, 535 d xDrive, 535 i xDrive, M 550 d xDrive	with clamps	<b>LM-10100S</b>		d1=15.5; d2=66; L [mm]=195

### 5 GRAN TURISMO (F07)

10/2009 →

Mounting, automatic transmission	530 d, 535 d, 535 i		<b>F8-7038</b>		
Control Arm-/Trailing Arm Bush	520 d, 530 d, 530 d xDrive, 535 d, 535 d xDrive, 535 i, 535 i xDrive, 550 i, 550 i xDrive		<b>F8-8002</b>		H=86; d=14; D=70
Bellow, steering	530 d, 530 d xDrive, 535 d, 535 d xDrive, 535 i, 535 i xDrive, 550 i, 550 i xDrive	with clamps	<b>LM-10100S</b>		d1=15.5; d2=66; L [mm]=195

### 6 (E24)

04/1976 → 09/1990

Dust Cover Kit, shock absorber	628 CSI, 630 CS, 633 CSI, 635 CSI		<b>AK-735004</b>		
Dust Cover Kit, shock absorber	628 CSI, 630 CS, 633 CSI, 635 CSI		<b>AK-735015</b>		
Bush, steering arm shaft	628 CSI, 635 CSI, M 635 CSI	09/1986 →	<b>F7-2039</b>		H=55; d=10; D1=27; D2=36
Bush, steering arm shaft	635 CSI		<b>F7-2039</b>		H=55; d=10; D1=27; D2=36
Top Strut Mounting	628 CSI, 635 CSI	05/1982 →;	<b>F8-5419</b>		Bolt Distance [mm]=87; d=14, 31; D=130
Top Strut Mounting	633 CSI, 635 CSI, M 635 CSI		<b>F8-5419</b>		Bolt Distance [mm]=87; d=14, 31; D=130
Rubber Buffer, suspension	628 CSI, 635 CSI, M 635 CSI		<b>F8-5690</b>		H=85
Mounting, axle beam	628 CSI, 635 CSI, M 635 CSI		<b>F8-5741</b>		H=85; d=15; D=70
Control Arm-/Trailing Arm Bush	628 CSI, 635 CSI	ABS; 05/1982 →	<b>F8-7352</b>		d=12; L=67; D=44
Control Arm-/Trailing Arm Bush	635 CSI, M 635 CSI	ABS	<b>F8-7352</b>		d=12; L=67; D=44
Repair Kit, link	628 CSI, 635 CSI	ABS; 05/1982 →	<b>F8-7352S</b>		d=12; L=67; D=44
Repair Kit, link	635 CSI, M 635 CSI	ABS	<b>F8-7352S</b>		d=12; L=67; D=44
Protective Cap/Bellow, shock absorber	628 CSI, 635 CSI	05/1982 →	<b>F8-7685</b>		H=91
Protective Cap/Bellow, shock absorber	635 CSI		<b>F8-7685</b>		H=91
Control Arm-/Trailing Arm Bush	628 CSI, 635 CSI	05/1982 →	<b>G7-767</b>		L=50; Mounting points diam.[mm]=14,1
Control Arm-/Trailing Arm Bush	635 CSI, M 635 CSI		<b>G7-767</b>		L=50; Mounting points diam.[mm]=14,1
Control Arm-/Trailing Arm Bush	628 CSI, 633 CSI, 635 CSI	06/1982 →	<b>G9-527</b>		H1=42; H2=52; d=12; D=46.5
Control Arm-/Trailing Arm Bush	635 CSI, M 635 CSI		<b>G9-527</b>		H1=42; H2=52; d=12; D=46.5
Control Arm-/Trailing Arm Bush	628 CSI, 635 CSI	05/1982 →	<b>G9-637</b>		H1=37; H2=50; d=14; D=58

<b>AK-735004</b>	<b>AK-735015</b>	<b>F7-2039</b>	<b>F8-5419</b>	<b>F8-5690</b>	<b>F8-5741</b>	<b>F8-7038</b>
Ref.Nr.:	Ref.Nr.:	Ref.Nr.: 32211136452	Ref.Nr.: 31331124508	Ref.Nr.: 31331125215	Ref.Nr.: 33311127533	Ref.Nr.: 22316761094
<b>F8-7352</b>	<b>F8-7352S</b>	<b>F8-7685</b>	<b>F8-8002</b>	<b>G7-767</b>	<b>G9-527</b>	<b>G9-637</b>
Ref.Nr.: 33321123462	Ref.Nr.: 33321123462	Ref.Nr.: 1134314	Ref.Nr.: 31126775145	Ref.Nr.: 33321123463	Ref.Nr.: 31121124622	Ref.Nr.: 31121126394
<b>LM-10100S</b>						
Ref.Nr.: 32106765782						

**Article Description****Article Nr.****Fitting Position**

<b>6 (E24)</b>			<b>04/1976 → 09/1990</b>		
Control Arm-/Trailing Arm Bush	633 CSI	09/1982 →	<b>G9-637</b>		H1=37; H2=50; d=14; D=58
Control Arm-/Trailing Arm Bush	635 CSI, M 635 CSI		<b>G9-637</b>		H1=37; H2=50; d=14; D=58
<b>6 (E63)</b>			<b>01/2004 → 07/2010</b>		
Alternator Freewheel Clutch	630 i		<b>F5-1053</b>		
Anti-Friction Bearing	M		<b>F8-3063</b>		
Bearing, wheel bearing housing	630 i, 635 d, 645 Ci, 650 i, M		<b>F8-5299</b>		H=67; H1=60; d=16; D=57; D1=52
Top Strut Mounting	630 i, 635 d, 645 Ci, 650 i		<b>F8-5433</b>		
Protective Cap/Bellow, shock absorber	630 i, 635 d, 645 Ci, 650 i, M	Universal	<b>F8-6545</b>		H=140
Joint, propshaft	635 d, 650 i		<b>F8-6764</b>		d=44.5; D=155; Thick./Strength 1 [mm]=30
Joint, propshaft	645 Ci	04/2005 →;	<b>F8-6764</b>		d=44.5; D=155; Thick./Strength 1 [mm]=30
Joint, propshaft	630 i		<b>F8-6767</b>		
Control Arm-/Trailing Arm Bush	630 i, 635 d, 645 Ci, 650 i, M		<b>F8-6774</b>		H=76; d=12.2; D=69.9
Mounting, automatic transmission	645 Ci, 650 i		<b>F8-7036</b>		
Mounting, automatic transmission	635 d		<b>F8-7038</b>		
Mounting, automatic transmission	630 i		<b>F8-7040</b>		
Mounting, manual transmission	M		<b>F8-7050</b>		
Protective Cap/Bellow, shock absorber	630 i, 635 d, 645 Ci, 650 i, M	Available as universal article: F8-6545	<b>F8-7336</b>		H=136
Bearing, wheel bearing housing	630 i, 635 d, 645 Ci, 650 i, M	with lock ring	<b>F8-7353</b>		H=67; H1=60; d=16; D=57; D1=52
Top Strut Mounting	630 i, 635 d, 645 Ci, 650 i		<b>F8-7604</b>		
Belt Pulley, crankshaft	635 d	Number of Ribs: 3, 5; Parameter: 6PK + 4PK	<b>F8-7641</b>		
Engine Mounting	630 i		<b>F8-8201</b>		
Bellow, steering	630 i, 635 d, 645 Ci, 650 i, M	with clamps	<b>LM-10100S</b>		d1=15.5; d2=66; L [mm]=195
<b>6 Convertible (E64)</b>			<b>04/2004 → 07/2010</b>		
Alternator Freewheel Clutch	630 i		<b>F5-1053</b>		
Anti-Friction Bearing	M		<b>F8-3063</b>		
Bearing, wheel bearing housing	630 i, 635 d, 645 Ci, 650 i, M		<b>F8-5299</b>		H=67; H1=60; d=16; D=57; D1=52
Top Strut Mounting	630 i, 635 d, 645 Ci, 650 i		<b>F8-5433</b>		

<b>F5-1053</b>	<b>F8-3063</b>	<b>F8-5299</b>	<b>F8-5433</b>	<b>F8-6545</b>	<b>F8-6764</b>	<b>F8-6767</b>
Ref.Nr.: 12314466273	Ref.Nr.: 1090612	Ref.Nr.: 33321090504	Ref.Nr.: 31331094616	Ref.Nr.: 0146239	Ref.Nr.: 26117542238	Ref.Nr.: 26117522027
<b>F8-6774</b>	<b>F8-7036</b>	<b>F8-7038</b>	<b>F8-7040</b>	<b>F8-7050</b>	<b>F8-7336</b>	<b>F8-7353</b>
Ref.Nr.: 31120305612	Ref.Nr.: 22316773825	Ref.Nr.: 22316761094	Ref.Nr.: 22316771741	Ref.Nr.: 22312283285	Ref.Nr.: 31331094749	Ref.Nr.: 33321090504
<b>F8-7604</b>	<b>F8-7641</b>	<b>F8-8201</b>	<b>G9-637</b>	<b>LM-10100S</b>		
Ref.Nr.: 33526753810	Ref.Nr.: 11237793593	Ref.Nr.: 22116761090	Ref.Nr.: 31121126394	Ref.Nr.: 32106765782		

Article Description



Article Nr.

Fitting Position



### 6 Convertible (E64)

04/2004 → 07/2010

Protective Cap/Bellow, shock absorber	630 i, 635 d, 645 Ci, 650 i, M	Universal	F8-6545		H=140
Joint, propshaft	635 d, 650 i		F8-6764		d=44.5; D=155; Thick./Strength 1 [mm]=30
Joint, propshaft	645 Ci	04/2005 →;	F8-6764		d=44.5; D=155; Thick./Strength 1 [mm]=30
Joint, propshaft	630 i		F8-6767		
Control Arm-/Trailing Arm Bush	630 i, 635 d, 645 Ci, 650 i, M		F8-6774		H=76; d=12.2; D=69.9
Mounting, automatic transmission	645 Ci, 650 i		F8-7036		
Mounting, automatic transmission	635 d		F8-7038		
Mounting, automatic transmission	630 i		F8-7040		
Protective Cap/Bellow, shock absorber	630 i, 635 d, 645 Ci, 650 i, M	Available as universal article: F8-6545	F8-7336		H=136
Bearing, wheel bearing housing	630 i, 635 d, 645 Ci, 650 i, M	with lock ring	F8-7353		H=67; H1=60; d=16; D=57; D1=52
Belt Pulley, crankshaft	635 d	Number of Ribs: 3, 5; Parameter: 6PK + 4PK	F8-7641		
Engine Mounting	630 i		F8-8201		
Bellow, steering	630 i, 635 d, 645 Ci, 650 i, M	with clamps	LM-10100S		d1=15.5; d2=66; L [mm]=195

### 6 Convertible (F12)

03/2011 →

Mounting, automatic transmission	640 d, 640 i		F8-7038		
Bellow, steering	640 d xDrive, 640 i xDrive, 650 i xDrive, M	with clamps	LM-10100S		d1=15.5; d2=66; L [mm]=195

### 6 Coupe (F13)

11/2010 →

Mounting, automatic transmission	640 d, 640 i		F8-7038		
Bellow, steering	640 d xDrive, 640 i xDrive, 650 i xDrive, M	with clamps	LM-10100S		d1=15.5; d2=66; L [mm]=195

### 6 Gran Coupe (F06)

09/2011 →

Mounting, automatic transmission	640 d, 640 i		F8-7038		
Bellow, steering	640 d xDrive, 640 i xDrive, 650 i xDrive, M	with clamps	LM-10100S		d1=15.5; d2=66; L [mm]=195

### 7 (E23)

05/1977 → 08/1986

Dust Cover Kit, shock absorber	728, 728 i, 730, 733 i, 735 i, 745 i		AK-735004		
Dust Cover Kit, shock absorber	728, 730		AK-735015		
Dust Cover Kit, shock absorber	728 i, 733 i, 735 i		AK-735016		
Rubber Buffer, suspension	728, 728 i, 730, 733 i, 735 i, 745 i		F8-5690		H=85

<b>AK-735004</b>	<b>AK-735015</b>	<b>AK-735016</b>	<b>F8-5690</b>	<b>F8-5741</b>	<b>F8-6545</b>	<b>F8-6764</b>
Ref.Nr.:	Ref.Nr.:	Ref.Nr.:	Ref.Nr.: 31331125215	Ref.Nr.: 33311127533	Ref.Nr.: 0146239	Ref.Nr.: 26117542238
<b>F8-6767</b>	<b>F8-6774</b>	<b>F8-7036</b>	<b>F8-7038</b>	<b>F8-7040</b>	<b>F8-7336</b>	<b>F8-7353</b>
Ref.Nr.: 26117522027	Ref.Nr.: 31120305612	Ref.Nr.: 22316773825	Ref.Nr.: 22316761094	Ref.Nr.: 22316771741	Ref.Nr.: 31331094749	Ref.Nr.: 33321090504
<b>F8-7641</b>	<b>F8-8201</b>	<b>LM-10100S</b>				
Ref.Nr.: 11237793593	Ref.Nr.: 22116761090	Ref.Nr.: 32106765782				



**Article Description****Article Nr.****Fitting Position**

<b>7 (E23)</b>				<b>05/1977 → 08/1986</b>	
Mounting, axle beam	728 i, 733 i, 735 i, 745 i		<b>F8-5741</b>		H=85; d=15; D=70
Control Arm-/Trailing Arm Bush	728 i, 732 i, 735 i	09/1982 →;	<b>F8-7352</b>		d=12; L=67; D=44
Control Arm-/Trailing Arm Bush	728 i, 745 i	09/1982 →;	<b>F8-7352</b>		d=12; L=67; D=44
Control Arm-/Trailing Arm Bush	732 i, 735 i	09/1982 →;	<b>F8-7352</b>		d=12; L=67; D=44
Control Arm-/Trailing Arm Bush	735 i	01/1985 →	<b>F8-7352</b>		d=12; L=67; D=44
Control Arm-/Trailing Arm Bush	735 i		<b>F8-7352</b>		d=12; L=67; D=44
Control Arm-/Trailing Arm Bush	735 i		<b>F8-7352</b>		d=12; L=67; D=44
Control Arm-/Trailing Arm Bush	745 i		<b>F8-7352</b>		d=12; L=67; D=44
Repair Kit, link	728 i, 732 i, 735 i	09/1982 →;	<b>F8-7352S</b>		d=12; L=67; D=44
Repair Kit, link	728 i, 745 i	09/1982 →;	<b>F8-7352S</b>		d=12; L=67; D=44
Repair Kit, link	732 i, 735 i	09/1982 →;	<b>F8-7352S</b>		d=12; L=67; D=44
Repair Kit, link	735 i	01/1985 →	<b>F8-7352S</b>		d=12; L=67; D=44
Repair Kit, link	735 i		<b>F8-7352S</b>		d=12; L=67; D=44
Repair Kit, link	735 i		<b>F8-7352S</b>		d=12; L=67; D=44
Repair Kit, link	745 i		<b>F8-7352S</b>		d=12; L=67; D=44
Control Arm-/Trailing Arm Bush	728 i, 735 i, 745 i	09/1982 →	<b>G7-767</b>		L=50; Mounting points diam.[mm]=14,1
Control Arm-/Trailing Arm Bush	733 i, 735 i, 745 i		<b>G7-767</b>		L=50; Mounting points diam.[mm]=14,1
Control Arm-/Trailing Arm Bush	728, 728 i, 730, 733 i, 735 i, 745 i		<b>G9-559</b>		H=55; d=14; D=50
<b>7 (E32)</b>				<b>09/1986 → 09/1994</b>	
Dust Cover Kit, shock absorber	All Models		<b>AK-735004</b>		
Bush, steering arm shaft	All Models		<b>F7-2039</b>		H=55; d=10; D1=27; D2=36
Control Arm-/Trailing Arm Bush	740 i,iL V8, 750 i,iL V12	Green; for OE: 31121130089, 31121130090, 31121130597, 31121130598, 31121139999, 31121140000	<b>F8-5021</b>		H1=48; H2=56; d=14; D=58
Stabiliser Mounting	730 i,iL V8		<b>F8-5119</b>		d=24; L=60; D=51
Stabiliser Mounting	730 i,iL, 740 i,iL V8, 750 i,iL V12		<b>F8-5119</b>		d=24; L=60; D=51
Stabiliser Mounting	735 i,iL		<b>F8-5119</b>		d=24; L=60; D=51
Mounting, axle beam	All Models		<b>F8-5317</b>		d=15; D=80
Stabiliser Mounting	All Models		<b>F8-5689</b>		d=15; L=40; D=34



**Article Description**

**Article Nr.**
**Fitting Position**

<b>7 (E32)</b>		<b>09/1986 → 09/1994</b>	
Rubber Buffer, suspension	730 i,iL, 730 i,iL V8, 735 i,iL, 740 i,iL V8, 750 i,iL V12	<b>F8-5690</b>	H=85
Mounting, transfer gear	All Models	<b>F8-5771</b>	
Control Arm-/Trailing Arm Bush	All Models	<b>F8-5772</b>	H=60; d=12,5; D=51
Rubber Buffer, suspension	730 i,iL, 730 i,iL V8, 735 i,iL, 740 i,iL V8	for OE: 33531135624	<b>F8-5867</b> H=99
Rubber Buffer, suspension	730 i,iL, 735 i,iL	03/1988 →	<b>F8-5869</b> H=90
Top Strut Mounting	All Models	<b>F8-5932</b>	
Mounting, automatic transmission	730 i,iL, 735 i,iL	<b>F8-6491</b>	H=34; D=36, 50; Outer Thread [mm]=M8 x 1,25mm
Joint, propshaft	730 i,iL V8	<b>F8-6763</b>	d=50; D=128; Thick./Strength 1 [mm]=39
Control Arm-/Trailing Arm Bush	730 i,iL, 730 i,iL V8	<b>F8-7352</b>	d=12; L=67; D=44
Control Arm-/Trailing Arm Bush	735 i,iL	<b>F8-7352</b>	d=12; L=67; D=44
Repair Kit, link	730 i,iL, 730 i,iL V8	<b>F8-7352S</b>	d=12; L=67; D=44
Repair Kit, link	735 i,iL	<b>F8-7352S</b>	d=12; L=67; D=44
Protective Cap/Bellow, shock absorber	All Models	<b>F8-7685</b>	H=91
Control Arm-/Trailing Arm Bush	All Models	<b>G7-767</b>	L=50; Mounting points diam.[mm]=14,1
Control Arm-/Trailing Arm Bush	All Models	<b>G9-527</b>	H1=42; H2=52; d=12; D=46,5
Control Arm-/Trailing Arm Bush	730 i,iL, 730 i,iL V8, 735 i,iL	beige/brown, White/Brown; for OE: 31121130089, 31121130090, 31121130597, 31121130598, 31121139999, 31121140000	<b>G9-689</b> H1=48; H2=56; d=14; D=58
<b>7 (E38)</b>		<b>10/1994 → 11/2001</b>	
Bush, steering arm shaft	725 tds, 728 i,iL, 730 d, 730 i,iL, 735 i,iL, 740 i,iL, 750 i,iL	<b>F7-2039</b>	H=55; d=10; D1=27; D2=36
Anti-Friction Bearing	725 tds, 728 i,iL, 730 d, 730 i,iL, 735 i,iL, 740 d, 740 i,iL, 750 i,iL	<b>F8-3063</b>	
Bearing, wheel bearing housing	All Models	<b>F8-5299</b>	H=67; H1=60; d=16; D=57; D1=52
Engine Mounting	730 i,iL, 740 i,iL, 750 i,iL	<b>F8-5425</b>	
Engine Mounting	735 i,iL, 740 i,iL	<b>F8-5425</b>	
Engine Mounting	730 i,iL, 740 i,iL, 750 i,iL	<b>F8-5426</b>	
Engine Mounting	735 i,iL, 740 i,iL	<b>F8-5426</b>	
Belt Pulley, crankshaft	728 i,iL	09/1998 →	<b>F8-5662</b>
Rubber Buffer, suspension	725 tds, 728 i,iL, 730 d, 730 i,iL, 735 i,iL, 740 d, 740 i,iL, 750 i,iL	<b>F8-5690</b>	H=85

<b>F7-2039</b>	<b>F8-3063</b>	<b>F8-5299</b>	<b>F8-5425</b>	<b>F8-5426</b>	<b>F8-5662</b>	<b>F8-5690</b>
Ref.Nr.: 32211136452	Ref.Nr.: 1090612	Ref.Nr.: 33321090504	Ref.Nr.: 22111092824	Ref.Nr.: 22111092823	Ref.Nr.: 1 438 995	Ref.Nr.: 31331125215
<b>F8-5766</b>	<b>F8-5771</b>	<b>F8-5772</b>	<b>F8-5867</b>	<b>F8-5869</b>	<b>F8-5932</b>	<b>F8-6491</b>
Ref.Nr.: 31331090611	Ref.Nr.: 33311132257	Ref.Nr.: 33171130874	Ref.Nr.: 33531135624	Ref.Nr.: 31331140140	Ref.Nr.: 1132088	Ref.Nr.: 23 71 1 131 664
<b>F8-6763</b>	<b>F8-7352</b>	<b>F8-7352S</b>	<b>F8-7685</b>	<b>G7-767</b>	<b>G9-527</b>	<b>G9-689</b>
Ref.Nr.: 26111227717	Ref.Nr.: 33321123462	Ref.Nr.: 33321123462	Ref.Nr.: 1134314	Ref.Nr.: 33321123463	Ref.Nr.: 31121124622	Ref.Nr.: 31121139456

**Article Description****Article Nr.****Fitting Position**

<b>7 (E38)</b>		<b>10/1994 → 11/2001</b>	
Top Strut Mounting	725 tds, 728 i,iL, 730 d, 730 i,iL, 735 i,iL, 740 d, 740 i,iL, 750 i,iL		
Top Strut Mounting	725 tds, 728 i,iL, 730 d, 730 i,iL, 735 i,iL, 740 d, 740 i,iL, 750 i,iL		
Top Strut Mounting	725 tds, 728 i,iL, 730 d, 730 i,iL, 735 i,iL, 740 d, 740 i,iL		
Rubber Buffer, suspension	725 tds, 728 i,iL, 730 d, 730 i,iL, 735 i,iL, 740 d, 740 i,iL, 750 i,iL	for OE: 33531135624	H=99
Rubber Buffer, suspension	725 tds, 728 i,iL, 730 d, 730 i,iL, 735 i,iL, 740 d, 740 i,iL, 750 i,iL		H=90
Mounting, axle beam	725 tds, 728 i,iL, 730 d, 730 i,iL, 735 i,iL, 740 d, 740 i,iL, 750 i,iL		H=90; d=19; D=81
Rubber Buffer, suspension	725 tds, 728 i,iL, 730 d, 730 i,iL, 735 i,iL, 740 d, 740 i,iL	for OE: 33531091031; <b>ST</b>	L=90
Mounting, automatic transmission	725 tds, 730 d, 730 i,iL, 740 i,iL		H=34; D=36, 50; Outer Thread [mm]=M8 x 1,25mm
Mounting, automatic transmission	735 i,iL	M62 B (35 8 S1)	H=34; D=36, 50; Outer Thread [mm]=M8 x 1,25mm
Joint, propshaft	725 tds, 735 i,iL		d=50; D=128; Thick./Strength 1 [mm]=39
Joint, propshaft	730 i,iL		d=50; D=128; Thick./Strength 1 [mm]=39
Engine Mounting	728 i,iL		
Engine Mounting	728 i,iL		
Bearing, wheel bearing housing	All Models	with lock ring	H=67; H1=60; d=16; D=57; D1=52
Control Arm-/Trailing Arm Bush	725 tds, 728 i,iL, 730 d, 730 i,iL, 735 i,iL, 740 d, 740 i,iL, 750 i,iL		H=40; d=10; D=48
Protective Cap/Bellow, shock absorber	725 tds, 728 i,iL, 730 d, 730 i,iL, 735 i,iL, 740 d, 740 i,iL, 750 i,iL	<b>ST</b>	H=86
Protective Cap/Bellow, shock absorber	725 tds, 728 i,iL, 730 d, 730 i,iL, 735 i,iL, 740 d, 740 i,iL, 750 i,iL		H=200

<b>7 (E65, E66, E67)</b>		<b>11/2001 → 12/2009</b>	
Dust Cover Kit, shock absorber	730 d, 730 i,Li, 730 Ld, 735 i, 735 i,Li, 740 d, 740 i,Li, 745 d, 745 i,Li, 750 i,Li, 760 i,Li	<b>AK-735176</b>	
Dust Cover Kit, shock absorber	730 d, 730 i,Li, 730 Ld, 735 i, 735 i,Li, 740 d, 740 i,Li, 745 d, 745 i,Li, 750 i,Li, 760 i,Li	<b>AK-735177</b>	
Alternator Freewheel Clutch	3.0 730 i, Li, 730 i,Li	<b>F5-1053</b>	
Anti-Friction Bearing	730 d, 730 i,Li, 730 Ld, 735 i,Li, 740 d, 740 i,Li, 745 d, 745 i,Li, 750 i,Li, 760 i,Li	<b>F8-3063</b>	
Bearing, wheel bearing housing	3.0 730 i, Li, 730 d, 730 i,Li, 730 Ld, 735 i, 735 i,Li, 740 d, 740 i,Li, 745 d, 745 i,Li, 750 i,Li, 760 i,Li	<b>F8-5299</b>	H=67; H1=60; d=16; D=57; D1=52
Belt Pulley, crankshaft	730 i,Li	<b>F8-5661</b>	
Rubber Buffer, suspension	3.0 730 i, Li, 730 i,Li, 730 Ld, 735 i,Li, 740 d, 740 i,Li, 745 d, 745 i,Li, 750 i,Li	<b>F8-5690</b>	H=85

<b>AK-735176</b>	<b>AK-735177</b>	<b>F5-1053</b>	<b>F8-3063</b>	<b>F8-5299</b>	<b>F8-5661</b>	<b>F8-5690</b>
Ref.Nr.: 33536758088	Ref.Nr.: 31331096309	Ref.Nr.: 12314466273	Ref.Nr.: 1090612	Ref.Nr.: 33321090504	Ref.Nr.: 11237513862	Ref.Nr.: 31331125215
<b>F8-5766</b>	<b>F8-5774</b>	<b>F8-5865</b>	<b>F8-5867</b>	<b>F8-5869</b>	<b>F8-5879</b>	<b>F8-6087</b>
Ref.Nr.: 31331090611	Ref.Nr.: 33521091238	Ref.Nr.: 33521090309	Ref.Nr.: 33531135624	Ref.Nr.: 31331140140	Ref.Nr.: 33311090956	Ref.Nr.: 33531091031
<b>F8-6491</b>	<b>F8-6763</b>	<b>F8-6828</b>	<b>F8-6829</b>	<b>F8-7353</b>	<b>F8-7602</b>	<b>F8-7727</b>
Ref.Nr.: 23 71 1 131 664	Ref.Nr.: 26111227717	Ref.Nr.: 22111092599	Ref.Nr.: 22111092600	Ref.Nr.: 33321090504	Ref.Nr.: 33321097264	Ref.Nr.: 31331137932

**Article Description**

**Article Nr.**
**Fitting Position**

<b>7 (E65, E66, E67)</b>		<b>11/2001 → 12/2009</b>	
Rubber Buffer, suspension	730 d, 735 i	<b>ST</b>	<b>F8-5690</b>
Rubber Buffer, suspension	730 d, 735 i		<b>F8-5690</b>
Top Strut Mounting	730 d, 730 i, Li, 735 i, Li, 740 d, 740 i, Li, 745 d, 745 i, Li, 750 i, Li, 760 i, Li		<b>F8-6084</b>
Control Arm-/Trailing Arm Bush	730 d, 730 i, Li, 735 i, Li, 740 d, 745 i, Li, 760 i, Li		<b>F8-6133</b>
Joint, propshaft	730 i, Li, 740 i, Li, 750 i, Li		<b>F8-6764</b>
Protective Cap/Bellow, shock absorber	730 d, 730 i, Li, 730 Ld, 735 i, 735 i, Li, 740 d, 740 i, Li, 745 d, 745 i, Li, 750 i, Li, 760 i, Li		<b>F8-7337</b>
Bearing, wheel bearing housing	3.0 730 i, Li, 730 d, 730 i, Li, 730 Ld, 735 i, 735 i, Li, 740 d, 740 i, Li, 745 d, 745 i, Li, 750 i, Li, 760 i, Li	with lock ring	<b>F8-7353</b>
Top Strut Mounting	3.0 730 i, Li, 730 d, 730 i, Li, 730 Ld, 735 i, 735 i, Li, 740 d, 740 i, Li, 745 d, 745 i, Li, 750 i, Li, 760 i, Li		<b>F8-7604</b>
Belt Pulley, crankshaft	730 d, 730 Ld	Number of Ribs: 3, 5; Parameter: 6PK + 4PK	<b>F8-7641</b>
<b>7 (F01, F02, F03, F04)</b>		<b>06/2008 → 12/2015</b>	
Mounting, automatic transmission	730 d, 740 d, 740 i, ActiveHybrid		<b>F8-7038</b>
Control Arm-/Trailing Arm Bush	730 d, 730 i, 740 d, 740 d xDrive, 740 i, 750 d xDrive, 750 i, 750 i xDrive, 760 i, ActiveHybrid		<b>F8-8002</b>
Bellow, steering	730 d, 730 d xDrive, 730 i, 740 d, 740 d xDrive, 740 i, 750 d xDrive, 750 i, 750 i xDrive, 760 i, ActiveHybrid	with clamps	<b>LM-10100S</b>
<b>8 (E31)</b>		<b>04/1990 → 12/1999</b>	
Bush, steering arm shaft	840 Ci, 840 i, 850 Ci, 850 CSI, 850 i, Ci		<b>F7-2039</b>
Control Arm-/Trailing Arm Bush	840 Ci, 840 i, 850 Ci, 850 CSI, 850 i, Ci	Green; for OE: 31121130089, 31121130090, 31121130597, 31121130598, 31121139999, 31121140000	<b>F8-5021</b>
Stabiliser Mounting	840 Ci, 840 i, 850 Ci, 850 i, Ci		<b>F8-5119</b>
Top Strut Mounting	840 Ci, 840 i, 850 Ci, 850 CSI, 850 i, Ci		<b>F8-7425</b>
Protective Cap/Bellow, shock absorber	840 Ci, 840 i, 850 Ci, 850 CSI, 850 i, Ci	<b>SP</b>	<b>F8-7738</b>
Control Arm-/Trailing Arm Bush	840 Ci, 840 i, 850 Ci, 850 CSI, 850 i, Ci		<b>G9-527</b>
<b>2500-3.3 (E3)</b>		<b>10/1968 → 04/1977</b>	
Dust Cover Kit, shock absorber	All Models		<b>AK-735004</b>
<b>X1 (E84)</b>		<b>03/2009 → 06/2015</b>	
Alternator Freewheel Clutch	sDrive 18 i		<b>F5-1051</b>
Alternator Freewheel Clutch	sDrive 18 i, xDrive 25 i, xDrive 28 i		<b>F5-1053</b>

<b>AK-735004</b>	<b>F5-1051</b>	<b>F5-1053</b>	<b>F7-2039</b>	<b>F8-5021</b>	<b>F8-5119</b>	<b>F8-5433</b>
Ref.Nr.:	Ref.Nr.: 12317516099	Ref.Nr.: 12314466273	Ref.Nr.: 32211136452	Ref.Nr.: 31121136607	Ref.Nr.: 31351131621	Ref.Nr.: 31331094616
<b>F8-5690</b>	<b>F8-6084</b>	<b>F8-6133</b>	<b>F8-6764</b>	<b>F8-7038</b>	<b>F8-7337</b>	<b>F8-7353</b>
Ref.Nr.: 31331125215	Ref.Nr.: 31336753966	Ref.Nr.: 31126765991	Ref.Nr.: 26117542238	Ref.Nr.: 22316761094	Ref.Nr.: 3133-1096309	Ref.Nr.: 33321090504
<b>F8-7425</b>	<b>F8-7604</b>	<b>F8-7641</b>	<b>F8-7738</b>	<b>F8-8002</b>	<b>G9-527</b>	<b>LM-10100S</b>
Ref.Nr.: 3133-1139436	Ref.Nr.: 33526753810	Ref.Nr.: 11237793593	Ref.Nr.: 31321125878	Ref.Nr.: 31126775145	Ref.Nr.: 31121124622	Ref.Nr.: 32106765782

**Article Description****Article Nr.****Fitting Position**

<b>X1 (E84)</b>		<b>03/2009 → 06/2015</b>	
Top Strut Mounting	sDrive 16 d, sDrive 18 d, sDrive 18 i, sDrive 20 d, sDrive 20 i, xDrive 18 d, xDrive 20 d, xDrive 20 i, xDrive 23 d, xDrive 25 d, xDrive 25 i, xDrive 28 i		<b>F8-5433</b>
Control Arm-/Trailing Arm Bush	sDrive 16 d, sDrive 18 d, sDrive 18 i, sDrive 20 d, sDrive 20 i, xDrive 18 d, xDrive 20 d, xDrive 20 i, xDrive 23 d, xDrive 25 d, xDrive 25 i, xDrive 28 i		<b>F8-6250</b>
Mounting, axle bracket	sDrive 18 d, sDrive 20 d, xDrive 18 d, xDrive 20 d, xDrive 23 d, xDrive 28 i		<b>F8-6476</b>
Protective Cap/Bellow, shock absorber	sDrive 16 d, sDrive 18 d, sDrive 18 i, sDrive 20 d, sDrive 20 i, xDrive 18 d, xDrive 20 d, xDrive 20 i, xDrive 23 d, xDrive 25 d, xDrive 25 i, xDrive 28 i	Universal	<b>F8-6545</b>
Control Arm-/Trailing Arm Bush	sDrive 18 d, sDrive 20 d		<b>F8-6724</b>
Engine Mounting	sDrive 18 d, sDrive 20 d	Aluminium	<b>F8-6999</b>
Engine Mounting	sDrive 18 d, sDrive 20 d	Aluminium	<b>F8-7000</b>
Rubber Buffer, suspension	sDrive 16 d, sDrive 18 d, sDrive 18 i, sDrive 20 d, sDrive 20 i, xDrive 20 d	<b>SP</b>	<b>F8-7334</b>
Protective Cap/Bellow, shock absorber	sDrive 16 d, sDrive 18 d, sDrive 18 i, sDrive 20 d, sDrive 20 i, xDrive 18 d, xDrive 20 d, xDrive 20 i, xDrive 23 d, xDrive 25 d, xDrive 25 i, xDrive 28 i	Available as universal article: F8-6545	<b>F8-7336</b>
Rubber Buffer, suspension	sDrive 16 d, sDrive 18 d, sDrive 18 i, sDrive 20 d, sDrive 20 i, xDrive 18 d, xDrive 20 d, xDrive 20 i, xDrive 23 d, xDrive 25 d, xDrive 25 i, xDrive 28 i	<b>ST</b>	<b>F8-7709</b>
Top Strut Mounting	sDrive 18 d, sDrive 18 i, sDrive 20 d, xDrive 18 d, xDrive 20 d, xDrive 23 d, xDrive 25 i, xDrive 28 i	Upper section	<b>F8-7724</b>
Engine Mounting	xDrive 18 d, xDrive 20 d, xDrive 23 d, xDrive 25 d, xDrive 25 i, xDrive 28 i		<b>F8-8163</b>
Mounting, axle beam	sDrive 18 d, sDrive 20 d, xDrive 18 d, xDrive 20 d, xDrive 23 d, xDrive 28 i		<b>F8-8230</b>
<b>X3 (E83)</b>		<b>01/2004 → 12/2011</b>	
Dust Cover Kit, shock absorber	2.0 d, 2.0 i, 2.5 i, 2.5 si, 3.0 d, 3.0 i, 3.0 sd, 3.0 si		<b>AK-735178</b>
Dust Cover Kit, shock absorber	2.0 d, 2.0 i, 2.5 i, 2.5 si, 3.0 d, 3.0 i, 3.0 sd, 3.0 si, xDrive 18 d, xDrive 20 d, xDrive 20 i, xDrive 25 i, xDrive 30 d, xDrive 30 i, xDrive 35 d		<b>AK-735179</b>
Alternator Freewheel Clutch	2.0 i, 2.5 si, 3.0 si, xDrive 20 i, xDrive 25 i, xDrive 30 i		<b>F5-1053</b>
Control Arm-/Trailing Arm Bush	2.0 d, 2.0 i, 2.5 i, 2.5 si, 3.0 d, 3.0 i, 3.0 sd, 3.0 si, xDrive 18 d, xDrive 20 d, xDrive 20 i, xDrive 25 i, xDrive 30 d, xDrive 30 i, xDrive 35 d		<b>F8-5311</b>
Mounting, axle beam	2.0 d, 2.0 i, 2.5 i, 2.5 si, 3.0 d, 3.0 i, 3.0 sd, 3.0 si, xDrive 18 d, xDrive 20 d, xDrive 20 i, xDrive 25 i, xDrive 30 d, xDrive 30 i, xDrive 35 d		<b>F8-5318</b>
Mounting, axle beam	2.0 d, 2.0 i, 2.5 i, 2.5 si, 3.0 d, 3.0 i, 3.0 sd, 3.0 si, xDrive 18 d, xDrive 20 d, xDrive 20 i, xDrive 25 i, xDrive 30 d, xDrive 30 i, xDrive 35 d		<b>F8-5319</b>

<b>AK-735178</b>	<b>AK-735179</b>	<b>F5-1053</b>	<b>F8-5311</b>	<b>F8-5318</b>	<b>F8-5319</b>	<b>F8-5320</b>
Ref.Nr.: 33503404974	Ref.Nr.: 31303411973	Ref.Nr.: 12314466273	Ref.Nr.: 33321097009	Ref.Nr.: 33311092515	Ref.Nr.: 33311092516	Ref.Nr.: 33311092517
<b>F8-5433</b>	<b>F8-6250</b>	<b>F8-6476</b>	<b>F8-6545</b>	<b>F8-6724</b>	<b>F8-6999</b>	<b>F8-7000</b>
Ref.Nr.: 31331094616	Ref.Nr.: 33326775552	Ref.Nr.: 33326763092	Ref.Nr.: 0146239	Ref.Nr.: 31120393540	Ref.Nr.: 22116768799	Ref.Nr.: 22116768800
<b>F8-7334</b>	<b>F8-7336</b>	<b>F8-7709</b>	<b>F8-7724</b>	<b>F8-8163</b>	<b>F8-8230</b>	
Ref.Nr.: 31336764085	Ref.Nr.: 31331094749	Ref.Nr.: 33534035353	Ref.Nr.: 33506771737	Ref.Nr.: 22316750858	Ref.Nr.: 33171093565	

**Article Description**

**Article Nr.**
**Fitting Position**

<b>X3 (E83)</b>		<b>01/2004 → 12/2011</b>	
Mounting, axle beam	2.0 d, 2.0 i, 2.5 i, 2.5 si, 3.0 d, 3.0 i, 3.0 sd, 3.0 si		<b>F8-5320</b>
Top Strut Mounting	2.0 d, 2.0 i, 2.5 i, 2.5 si, 3.0 d, 3.0 i, 3.0 sd, 3.0 si, xDrive 18 d, xDrive 20 d, xDrive 20 i, xDrive 25 i, xDrive 30 d, xDrive 30 i, xDrive 35 d		<b>F8-5433</b>
Belt Pulley, crankshaft	2.5 i, 3.0 i		<b>F8-5661</b>
Control Arm-/Trailing Arm Bush	2.0 d, 2.0 i, 2.5 i, 2.5 si, 3.0 d, 3.0 i, 3.0 sd, 3.0 si, xDrive 18 d, xDrive 20 i, xDrive 30 d		<b>F8-5746</b>
Mounting, axle beam	2.0 d, 2.0 i, 2.5 i, 3.0 d, 3.0 i, 3.0 sd		<b>F8-5886</b>
Control Arm-/Trailing Arm Bush	2.0 d, 2.0 i, 2.5 i, 2.5 si, 3.0 d, 3.0 i, 3.0 sd, 3.0 si, xDrive 18 d, xDrive 20 i, xDrive 30 d		<b>F8-6251</b>
Mounting, automatic transmission	2.0 d		<b>F8-6584</b>
Joint, propshaft	2.0 d, 2.0 i, 2.5 i, 3.0 d, 3.0 i, 3.0 sd		<b>F8-6763</b>
Joint, propshaft	2.0 d, 2.5 si, 3.0 sd, 3.0 si, xDrive 20 d, xDrive 25 i, xDrive 30 i, xDrive 35 d		<b>F8-6764</b>
Engine Mounting	2.5 i, 3.0 i		<b>F8-6995</b>
Engine Mounting	2.5 i, 2.5 si, 3.0 i, 3.0 si		<b>F8-6996</b>
Engine Mounting	2.0 d, xDrive 20 d		<b>F8-7006</b>
Mounting, automatic transmission	2.0 i, 2.5 si, 3.0 d, 3.0 sd, 3.0 si, xDrive 20 i, xDrive 25 i, xDrive 30 d, xDrive 30 i, xDrive 35 d		<b>F8-7037</b>
Rubber Buffer, suspension	2.0 d, 2.0 i, 2.5 i, 2.5 si, 3.0 d, 3.0 i, 3.0 sd, 3.0 si, xDrive 18 d, xDrive 20 d, xDrive 20 i, xDrive 25 i, xDrive 30 d, xDrive 30 i, xDrive 35 d		<b>F8-7332</b>
Belt Pulley, crankshaft	3.0 d, 3.0 sd	Number of Ribs: 3, 5; Parameter: 6PK + 4PK	<b>F8-7641</b>
Protective Cap/Bellow, shock absorber	2.0 d, 2.0 i, 2.5 i, 2.5 si, 3.0 d, 3.0 i, 3.0 sd, 3.0 si, xDrive 18 d, xDrive 20 d, xDrive 20 i, xDrive 25 i, xDrive 30 d, xDrive 30 i, xDrive 35 d		<b>F8-7738</b>
Top Strut Mounting	2.0 d, 2.0 i, 2.5 i, 2.5 si, 3.0 d, 3.0 i, 3.0 sd, 3.0 si, xDrive 18 d, xDrive 20 d, xDrive 20 i, xDrive 25 i, xDrive 30 d, xDrive 30 i, xDrive 35 d		<b>F8-7741</b>
Engine Mounting	2.5 i, 3.0 d, 3.0 i		<b>F8-8163</b>
Mounting, axle beam	2.0 d, 2.0 i, 2.5 i, 2.5 si, 3.0 d, 3.0 i, 3.0 sd, 3.0 si, xDrive 18 d, xDrive 20 d, xDrive 20 i, xDrive 25 i, xDrive 30 d, xDrive 30 i, xDrive 35 d		<b>F8-8230</b>
Control Arm-/Trailing Arm Bush	2.0 d, 2.0 i, 2.5 i, 2.5 si, 3.0 d, 3.0 i, 3.0 sd, 3.0 si, xDrive 18 d, xDrive 20 d, xDrive 20 i, xDrive 25 i, xDrive 30 d, xDrive 30 i, xDrive 35 d		<b>G9-527</b>
Bellow, steering	2.0 d, 2.5 i, 3.0 d, 3.0 i	03/2006 →; with clamps	<b>LM-10100S</b>
Bellow, steering	2.0 d, 2.5 si, 3.0 sd, 3.0 si, xDrive 18 d, xDrive 20 d, xDrive 20 i, xDrive 25 i, xDrive 30 d, xDrive 30 i, xDrive 35 d	with clamps	<b>LM-10100S</b>

<b>F8-5320</b>	<b>F8-5433</b>	<b>F8-5661</b>	<b>F8-5746</b>	<b>F8-5886</b>	<b>F8-6251</b>	<b>F8-6584</b>
Ref.Nr.: 33311092517	Ref.Nr.: 31331094616	Ref.Nr.: 11237513862	Ref.Nr.: 33321092247	Ref.Nr.: 33171093175	Ref.Nr.: 33313400023	Ref.Nr.: 22313400343
<b>F8-6763</b>	<b>F8-6764</b>	<b>F8-6995</b>	<b>F8-6996</b>	<b>F8-7006</b>	<b>F8-7037</b>	<b>F8-7332</b>
Ref.Nr.: 26111227717	Ref.Nr.: 26117542238	Ref.Nr.: 22113400335	Ref.Nr.: 22113400336	Ref.Nr.: 22113400341	Ref.Nr.: 22313400320	Ref.Nr.: 31303411973
<b>F8-7641</b>	<b>F8-7738</b>	<b>F8-7741</b>	<b>F8-8163</b>	<b>F8-8230</b>	<b>G9-527</b>	<b>LM-10100S</b>
Ref.Nr.: 11237793593	Ref.Nr.: 31321125878	Ref.Nr.: 33503413925	Ref.Nr.: 22316750858	Ref.Nr.: 33171093565	Ref.Nr.: 31121124622	Ref.Nr.: 32106765782

**Article Description****Article Nr.****Fitting Position**

<b>X3 (F25)</b>			<b>09/2010 →</b>		
Control Arm-/Trailing Arm Bush	sDrive 18d, xDrive 20 d, xDrive 20 i, xDrive 28 i, xDrive 30 d, xDrive 35 d, xDrive 35 i		<b>F8-6250</b>		H=55; d=14; D=47
Control Arm-/Trailing Arm Bush	sDrive 18 d, sDrive 18d, sDrive 20 i, xDrive 20 d, xDrive 20 i, xDrive 28 d, xDrive 28 i, xDrive 30 d, xDrive 35 d, xDrive 35 i		<b>F8-8093</b>		
<b>X4 (F26)</b>			<b>04/2014 →</b>		
Control Arm-/Trailing Arm Bush	xDrive 20 d, xDrive 20 i, xDrive 28 i, xDrive 30 d, xDrive 35 d, xDrive 35 i		<b>F8-6250</b>		H=55; d=14; D=47
<b>X5 (E53)</b>			<b>05/2000 → 12/2006</b>		
Dust Cover Kit, shock absorber	3.0 d, 3.0 i, 4.4 i, 4.6 is, 4.8 is	<b>SP, ST</b>	<b>AK-735171</b>		
Dust Cover Kit, shock absorber	3.0 d, 4.4 i, 4.6 is	<b>ST</b>	<b>AK-735412</b>		
Dust Cover Kit, shock absorber	3.0 i	<b>ST</b>	<b>AK-735413</b>		
Dust Cover Kit, shock absorber	3.0 i	07/2005 →; <b>ST</b>	<b>AK-735414</b>		
Anti-Friction Bearing	3.0 d, 3.0 i, 4.4 i, 4.6 is		<b>F8-3063</b>		
Bearing, wheel bearing housing	All Models		<b>F8-5299</b>		H=67; H1=60; d=16; D=57; D1=52
Mounting, axle beam	3.0 d, 3.0 i, 4.4 i, 4.6 is, 4.8 is		<b>F8-5300</b>		H=29; d=8; D=74
Belt Pulley, crankshaft	3.0 i	09/2002 →	<b>F8-5661</b>		
Belt Pulley, crankshaft	3.0 i		<b>F8-5662</b>		
Top Strut Mounting	All Models		<b>F8-6085</b>		
Rubber Buffer, suspension	All Models	<b>SP, ST</b>	<b>F8-6086</b>		H=90
Engine Mounting	3.0 d		<b>F8-6714</b>		
Joint, propshaft	3.0 d, 3.0 i, 4.4 i, 4.8 is		<b>F8-6763</b>		d=50; D=128; Thick./Strength 1 [mm]=39
Mounting, propshaft	3.0 d	M57 D30;	<b>F8-7056</b>		
Mounting, propshaft	3.0 d, 3.0 i, 4.4 i, 4.6 is, 4.8 is		<b>F8-7056</b>		
Rubber Buffer, suspension	3.0 d, 4.4 i, 4.6 is	<b>ST</b>	<b>F8-7331</b>		H=95
Rubber Buffer, suspension	3.0 i	07/2005 →; <b>ST</b>	<b>F8-7332</b>		H=90
Rubber Buffer, suspension	3.0 i	<b>ST</b>	<b>F8-7333</b>		H=85
Protective Cap/Bellow, shock absorber	3.0 d, 3.0 i, 4.4 i, 4.6 is		<b>F8-7337</b>		H=250
Bearing, wheel bearing housing	All Models	with lock ring	<b>F8-7353</b>		H=67; H1=60; d=16; D=57; D1=52
Top Strut Mounting	3.0 d, 3.0 i, 4.4 i, 4.6 is		<b>F8-7359</b>		
Spring pad	3.0 d, 3.0 i, 4.4 i, 4.6 is		<b>F8-7365</b>		
Belt Pulley, crankshaft	3.0 d	Number of Ribs: 3, 5; Parameter: 6PK + 4PK	<b>F8-7641</b>		
Protective Cap/Bellow, shock absorber	All Models		<b>F8-7738</b>		H=200



**Article Description**

**Article Nr.**
**Fitting Position**

<b>X5 (E53)</b>		<b>05/2000 → 12/2006</b>	
Control Arm-/Trailing Arm Bush	All Models	<b>F8-7797</b>	H=76; d=14; D=66.3
Stabiliser Mounting	3.0 d, 3.0 i, 4.4 i, 4.6 is, 4.8 is	<b>F8-7996</b>	D=29; L=54; W=65
Control Arm-/Trailing Arm Bush	All Models	<b>G9-527</b>	H1=42; H2=52; d=12; D=46.5
<b>X5 (E70)</b>		<b>02/2007 → 06/2013</b>	
Alternator Freewheel Clutch	3.0 si, xDrive 30 i	<b>F5-1053</b>	
Control Arm-/Trailing Arm Bush	3.0 d, 3.0 sd, 3.0 si, 4.8 i, M 50 d, xDrive 30 d, xDrive 30 i, xDrive 35 d, xDrive 35 i, xDrive 40 d, xDrive 48 i, xDrive 50 i	<b>F8-6719</b>	d=12.2; D=70.2
Control Arm-/Trailing Arm Bush	3.0 d, 3.0 sd, 3.0 si, 4.8 i	<b>F8-6720</b>	
Control Arm-/Trailing Arm Bush	3.0 d, 3.0 sd, 3.0 si, 4.8 i	<b>F8-6721</b>	
Joint, propshaft	3.0 sd, xDrive 35 d	<b>F8-6763</b>	d=50; D=128; Thick./Strength 1 [mm]=39
Top Strut Mounting	3.0 d, 3.0 sd, 3.0 si, 4.8 i, xDrive 30 d, xDrive 35 d, xDrive 35 i, xDrive 40 d, xDrive 50 i	<b>F8-7476</b>	
Protective Cap/Bellow, shock absorber	All Models	<b>F8-7487</b>	
Protective Cap/Bellow, shock absorber	All Models	<b>F8-7488</b>	
Belt Pulley, crankshaft	3.0 d, 3.0 sd	<b>F8-7641</b>	Number of Ribs: 3, 5; Parameter: 6PK + 4PK
<b>X6 (E71, E72)</b>		<b>05/2008 → 06/2014</b>	
Control Arm-/Trailing Arm Bush	30 d, 35 d, 35 i, 50 i, ActiveHybrid, M, M 50 d, xDrive 30 d, xDrive 35 d, xDrive 35 i, xDrive 40 d, xDrive 50 i	<b>F8-6719</b>	d=12.2; D=70.2
Control Arm-/Trailing Arm Bush	30 d, 35 d, 35 i, 50 i	<b>F8-6720</b>	
Control Arm-/Trailing Arm Bush	30 d, 35 d, 35 i, 50 i	<b>F8-6721</b>	
Joint, propshaft	30 d, 35 d, 35 i, 50 i, xDrive 30 d, xDrive 35 d, xDrive 35 i, xDrive 50 i	<b>F8-6763</b>	d=50; D=128; Thick./Strength 1 [mm]=39
Top Strut Mounting	30 d, 35 d, 35 i, 50 i, xDrive 30 d, xDrive 35 d, xDrive 35 i, xDrive 40 d, xDrive 50 i	<b>F8-7476</b>	
Protective Cap/Bellow, shock absorber	30 d, 35 d, 35 i, 50 i, xDrive 30 d, xDrive 35 d, xDrive 35 i, xDrive 40 d, xDrive 50 i	<b>F8-7487</b>	
Protective Cap/Bellow, shock absorber	30 d, 35 d, 35 i, 50 i, xDrive 30 d, xDrive 35 d, xDrive 35 i, xDrive 40 d, xDrive 50 i	<b>F8-7488</b>	
Belt Pulley, crankshaft	30 d, 35 d	<b>F8-7641</b>	Number of Ribs: 3, 5; Parameter: 6PK + 4PK
<b>Z1</b>		<b>06/1988 → 06/1991</b>	
Top Strut Mounting	All Models	<b>F8-5417</b>	

<b>F5-1053</b>	<b>F8-5417</b>	<b>F8-5419</b>	<b>F8-6719</b>	<b>F8-6720</b>	<b>F8-6721</b>	<b>F8-6763</b>
Ref.Nr.: 12314466273	Ref.Nr.: 33521125554	Ref.Nr.: 31331124508	Ref.Nr.: 31106778015	Ref.Nr.: 31 10 6 771 194	Ref.Nr.: 31 10 6 771 897	Ref.Nr.: 26111227717
<b>F8-7476</b>	<b>F8-7487</b>	<b>F8-7488</b>	<b>F8-7641</b>	<b>F8-7797</b>	<b>F8-7996</b>	<b>G9-527</b>
Ref.Nr.: 31336771515	Ref.Nr.: 31336776554	Ref.Nr.: 33526776132	Ref.Nr.: 11237793593	Ref.Nr.: 31121096372	Ref.Nr.: 31351097021	Ref.Nr.: 31121124622



**Article Description****Article Nr.****Fitting Position**

<b>Z1</b>			<b>06/1988 → 06/1991</b>		
Top Strut Mounting	All Models		<b>F8-5419</b>		Bolt Distance [mm]=87; d=14, 31; D=130
Protective Cap/Bellow, shock absorber	All Models		<b>F8-7685</b>		H=91
Control Arm-/Trailing Arm Bush	All Models		<b>G9-624</b>		H=33; d=18; D=60
Bellow, steering	All Models	with clamps	<b>LM-10052S</b>		d1=37; d2=44; L [mm]=165
<b>Z3 (E36)</b>			<b>10/1995 → 01/2003</b>		
Dust Cover Kit, shock absorber	1.8, 1.9, 2.0	<b>ST</b>	<b>AK-735126</b>		
Dust Cover Kit, shock absorber	1.8, 1.9, 2.0, 2.2, 2.8, 3.0, M 3.2		<b>AK-735154</b>		
Top Strut Mounting	1.8, 1.9, 2.0, 2.2, 2.8, 3.0, M 3.2		<b>F8-5030</b>		H=35; d=10
Bellow, steering	1.8, 1.9, 2.0, 2.8, M 3.2		<b>F8-5171</b>		Total Br. Drum Height [mm]=185
Engine Mounting	1.8, 1.9		<b>F8-5428</b>		
Top Strut Mounting	1.8, 1.9, 2.0, 2.2, 2.8, 3.0		<b>F8-5506</b>		
Control Arm-/Trailing Arm Bush	1.8, 1.9, 2.0, 2.2, 2.8, 3.0, M 3.2		<b>F8-5632</b>		H=57; d=12; D=45
Belt Pulley, crankshaft	2.0, 2.2, 3.0		<b>F8-5662</b>		
Belt Pulley, crankshaft	2.8	09/1998 →	<b>F8-5662</b>		
Rubber Buffer, suspension	1.8, 1.9, 2.0, 2.2, 2.8		<b>F8-5690</b>		H=85
Mounting, axle beam	1.8, 1.9, 2.0, 2.2, 2.8, 3.0, M 3.2		<b>F8-6080</b>		H=84; d=14; D1=59; D2=77
Control Arm-/Trailing Arm Bush	1.8, 1.9, 2.0, 2.2, 2.8, 3.0		<b>F8-6102</b>		
Control Arm-/Trailing Arm Bush	1.8, 1.9, 2.0, 2.2, 2.8, 3.0		<b>F8-6103</b>		
Engine Mounting	2.0, 2.2, 2.8, 3.0, M 3.2		<b>F8-6215</b>		
Mounting, automatic transmission	1.8, 1.9		<b>F8-6242</b>		H1=34; H2=69; D1=36; D2=50
Mounting, propshaft	1.8, 1.9, 2.0, 2.2, 2.8, 3.0		<b>F8-6777</b>		d=30
Mounting, propshaft	1.8, 1.9, 2.0, 2.8		<b>F8-6778</b>		
Mounting, propshaft	2.2, 3.0		<b>F8-6778</b>		
Joint, propshaft	M 3.2		<b>F8-6783</b>		
Protective Cap/Bellow, shock absorber	1.8, 1.9, 2.0, 2.2, 2.8, 3.0, M 3.2	<b>ST</b>	<b>F8-7727</b>		H=86
Engine Mounting	2.0, 2.2, 2.8, 3.0, M 3.2		<b>F8-8174</b>		
Control Arm-/Trailing Arm Bush	1.8, 1.9, 2.0, 2.8		<b>G9-625</b>		H=34; d=18; D=60
Control Arm-/Trailing Arm Bush	1.8, 1.9, 2.0, 2.8		<b>G9-625S</b>		H=34; d=18; D=60
Bellow, steering	1.8, 1.9, 2.0, 2.2, 2.8, 3.0, M 3.2	with clamps;	<b>LM-10011S</b>		d1=37; d2=51; L [mm]=185

<b>AK-735126</b>	<b>AK-735154</b>	<b>F8-5030</b>	<b>F8-5171</b>	<b>F8-5419</b>	<b>F8-5428</b>	<b>F8-5506</b>
Ref.Nr.: 33521136283	Ref.Nr.: 31331137932	Ref.Nr.: 33504035929	Ref.Nr.: 32111137070	Ref.Nr.: 31331124508	Ref.Nr.: 11811137238	Ref.Nr.: 31336764947
<b>F8-5632</b>	<b>F8-5662</b>	<b>F8-5690</b>	<b>F8-6080</b>	<b>F8-6102</b>	<b>F8-6103</b>	<b>F8-6215</b>
Ref.Nr.: 33321138722	Ref.Nr.: 1 438 995	Ref.Nr.: 31331125215	Ref.Nr.: 33311090945	Ref.Nr.: 31121136531	Ref.Nr.: 31121136532	Ref.Nr.: 11817837985
<b>F8-6242</b>	<b>F8-6777</b>	<b>F8-6778</b>	<b>F8-6783</b>	<b>F8-7685</b>	<b>F8-7727</b>	<b>F8-8174</b>
Ref.Nr.: 23711133487	Ref.Nr.: 26121229089	Ref.Nr.: 26121229089-PA	Ref.Nr.: 26112226527	Ref.Nr.: 1134314	Ref.Nr.: 31331137932	Ref.Nr.: 23711137817

Article Description



Article Nr.

Fitting Position



### Z3 Coupe (E36)

07/1997 → 06/2003

Dust Cover Kit, shock absorber	All Models		AK-735154		
Top Strut Mounting	All Models		F8-5030		H=35; d=10
Bellow, steering	2.8, M		F8-5171		Total Br. Drum Height [mm]=185
Top Strut Mounting	2.8, 3.0		F8-5506		
Control Arm-/Trailing Arm Bush	2.8, 3.0, M		F8-5632		H=57; d=12; D=45
Belt Pulley, crankshaft	2.8	09/1998 →	F8-5662		
Belt Pulley, crankshaft	3.0		F8-5662		
Mounting, axle beam	All Models		F8-6080		H=84; d=14; D1=59; D2=77
Control Arm-/Trailing Arm Bush	2.8, 3.0		F8-6102		
Control Arm-/Trailing Arm Bush	2.8, 3.0		F8-6103		
Engine Mounting	2.8, 3.0, M		F8-6215		
Mounting, propshaft	2.8, 3.0		F8-6777		d=30
Mounting, propshaft	2.8		F8-6778		
Mounting, propshaft	3.0		F8-6778		
Joint, propshaft	M		F8-6783		
Protective Cap/Bellow, shock absorber	All Models	ST	F8-7727		H=86
Engine Mounting	2.8, 3.0, M		F8-8174		
Control Arm-/Trailing Arm Bush	2.8		G9-625		H=34; d=18; D=60
Control Arm-/Trailing Arm Bush	2.8		G9-625S		H=34; d=18; D=60
Bellow, steering	All Models	with clamps;	LM-10011S		d1=37; d2=51; L [mm]=185

### Z4 (E85)

02/2003 → 02/2009

Dust Cover Kit, shock absorber	2.0 i, 2.2 i, 2.5 i, 2.5 si, 3.0 i, 3.0 si	ST	AK-735415		
Alternator Freewheel Clutch	2.0 i		F5-1051		
Alternator Freewheel Clutch	2.0 i, 2.5 i, 2.5 si, 3.0 si		F5-1053		
Anti-Friction Bearing	M		F8-3063		
Holder, control arm mounting	All Models	Aluminium	F8-5280		D=66
Holder, control arm mounting	All Models	Aluminium	F8-5281		D=66
Mounting, axle beam	All Models		F8-5320		H=63; d=20.5; D=72
Engine Mounting	2.2 i, 2.5 i, 2.5 si, 3.0 i, 3.0 si		F8-5348		
Top Strut Mounting	2.0 i, 2.2 i, 2.5 i, 2.5 si, 3.0 i, 3.0 si		F8-5506		
Control Arm-/Trailing Arm Bush	All Models		F8-5632		H=57; d=12; D=45



**Article Description****Article Nr.****Fitting Position**

<b>Z4 (E85)</b>				<b>02/2003 → 02/2009</b>	
Belt Pulley, crankshaft	2.2 i, 2.5 i, 3.0 i		<b>F8-5661</b>		
Control Arm-/Trailing Arm Bush	All Models		<b>F8-5746</b>		H=42, 66.5; d=12; D=35
Mounting, axle beam	2.2 i, 2.5 i, 2.5 si, 3.0 i, 3.0 si		<b>F8-5886</b>		H1=47; H2=40; D=47
Rubber Buffer, suspension	2.0 i, 2.2 i, 2.5 i, 3.0 i	<b>ST</b>	<b>F8-6088</b>		H=75
Control Arm-/Trailing Arm Bush	2.0 i, 2.2 i, 2.5 i, 2.5 si, 3.0 i, 3.0 si		<b>F8-6243</b>		H=55; d=20; D=60.4
Protective Cap/Bellow, shock absorber	All Models	Universal	<b>F8-6545</b>		H=140
Joint, propshaft	M		<b>F8-6783</b>		
Protective Cap/Bellow, shock absorber	All Models	Available as universal article: F8-6545	<b>F8-7336</b>		H=136
Protective Cap/Bellow, shock absorber	2.2 i, 2.5 i, 3.0 i		<b>F8-7684</b>		H=194
Stabiliser Mounting	2.0 i, 2.2 i		<b>F8-7918</b>		d=23
Stabiliser Mounting	2.2 i, 2.5 i, 3.0 i	M54	<b>F8-7976</b>		D=17
Stabiliser Mounting	2.5 i, 2.5 si, 3.0 si		<b>F8-7976</b>		D=17
Engine Mounting	All Models		<b>F8-8174</b>		
Mounting, axle beam	2.0 i, 2.2 i, 2.5 i, 2.5 si, 3.0 i, 3.0 si		<b>F8-8230</b>		
Suspension Kit	2.0 i, 2.2 i, 2.5 i, 2.5 si, 3.0 i, 3.0 si	Aluminium; with fastening material	<b>G8-544</b>		D=66
Bellow, steering	All Models	with clamps;	<b>LM-10011S</b>		d1=37; d2=51; L [mm]=185
Bellow, steering	All Models	with clamps	<b>LM-10078S</b>		d1=15; d2=55; L [mm]=186
<b>Z4 Coupe (E86)</b>				<b>03/2006 → 01/2009</b>	
Alternator Freewheel Clutch	3.0 si		<b>F5-1053</b>		
Anti-Friction Bearing	M		<b>F8-3063</b>		
Holder, control arm mounting	All Models	Aluminium	<b>F8-5280</b>		D=66
Holder, control arm mounting	All Models	Aluminium	<b>F8-5281</b>		D=66
Mounting, axle beam	All Models		<b>F8-5320</b>		H=63; d=20.5; D=72
Engine Mounting	3.0 si		<b>F8-5348</b>		
Top Strut Mounting	3.0 si		<b>F8-5506</b>		
Control Arm-/Trailing Arm Bush	All Models		<b>F8-5632</b>		H=57; d=12; D=45
Control Arm-/Trailing Arm Bush	All Models		<b>F8-5746</b>		H=42, 66.5; d=12; D=35
Mounting, axle beam	3.0 si		<b>F8-5886</b>		H1=47; H2=40; D=47
Protective Cap/Bellow, shock absorber	3.0 si	Universal	<b>F8-6545</b>		H=140
Joint, propshaft	M		<b>F8-6783</b>		

<b>F5-1053</b>	<b>F8-3063</b>	<b>F8-5280</b>	<b>F8-5281</b>	<b>F8-5320</b>	<b>F8-5348</b>	<b>F8-5506</b>
Ref.Nr.: 12314466273	Ref.Nr.: 1090612	Ref.Nr.: 31124004359	Ref.Nr.: 31126754900	Ref.Nr.: 33311092517	Ref.Nr.: 11811082583	Ref.Nr.: 31336764947
<b>F8-5632</b>	<b>F8-5661</b>	<b>F8-5746</b>	<b>F8-5886</b>	<b>F8-6088</b>	<b>F8-6243</b>	<b>F8-6545</b>
Ref.Nr.: 33321138722	Ref.Nr.: 11237513862	Ref.Nr.: 33321092247	Ref.Nr.: 33171093175	Ref.Nr.: 6778544	Ref.Nr.: 31121096982	Ref.Nr.: 0146239
<b>F8-6783</b>	<b>F8-7336</b>	<b>F8-7684</b>	<b>F8-7918</b>	<b>F8-7976</b>	<b>F8-8174</b>	<b>F8-8230</b>
Ref.Nr.: 26112226527	Ref.Nr.: 31331094749	Ref.Nr.: 1136283	Ref.Nr.: 31351097179	Ref.Nr.: 33551138104	Ref.Nr.: 23711137817	Ref.Nr.: 33171093565

Article Description



Article Nr.

Fitting Position



### Z4 Coupe (E86)

03/2006 → 01/2009

Protective Cap/Bellow, shock absorber	M		F8-7684		H=194
Stabiliser Mounting	3.0 si		F8-7976		D=17
Engine Mounting	All Models		F8-8174		
Suspension Kit	3.0 si	Aluminium; with fastening material	G8-544		D=66
Bellow, steering	All Models	with clamps;	LM-10011S		d1=37; d2=51; L [mm]=185
Bellow, steering	All Models	with clamps	LM-10078S		d1=15; d2=55; L [mm]=186

### Z4 (E89)

05/2009 →

Mounting, axle beam	sDrive23i, sDrive30i, sDrive35i		F8-5320		H=63; d=20.5; D=72
Mounting, axle beam	sDrive23i, sDrive30i		F8-5886		H1=47; H2=40; D=47
Protective Cap/Bellow, shock absorber	sDrive23i, sDrive30i, sDrive35i	Universal	F8-6545		H=140
Control Arm-/Trailing Arm Bush	sDrive23i, sDrive30i, sDrive35i		F8-6724		d=12; L1=64.5; L2=76; D=70
Protective Cap/Bellow, shock absorber	sDrive23i, sDrive30i, sDrive35i	Available as universal article: F8-6545	F8-7336		H=136
Engine Mounting	sDrive30i		F8-8174		

### Z8 (E52)

06/2000 → 06/2003

Anti-Friction Bearing	All Models		F8-3063		
Bearing, wheel bearing housing	All Models		F8-5299		H=67; H1=60; d=16; D=57; D1=52
Mounting, axle beam	All Models		F8-5879		H=90; d=19; D=81
Top Strut Mounting	All Models		F8-5923		
Bearing, wheel bearing housing	All Models	with lock ring	F8-7353		H=67; H1=60; d=16; D=57; D1=52
Control Arm-/Trailing Arm Bush	All Models		G9-658		H1=68; H2=60; d=12; D=58
Control Arm-/Trailing Arm Bush	All Models		G9-658S		H1=68; H2=60; d=12; D=58
Bellow, steering	All Models	with clamps;	LM-10012S		d1=39; d2=52; L [mm]=175

<b>F8-3063</b>	<b>F8-5299</b>	<b>F8-5320</b>	<b>F8-5879</b>	<b>F8-5886</b>	<b>F8-5923</b>	<b>F8-6545</b>
Ref.Nr.: 1090612	Ref.Nr.: 33321090504	Ref.Nr.: 33311092517	Ref.Nr.: 33311090956	Ref.Nr.: 33171093175	Ref.Nr.: 31331091708	Ref.Nr.: 0146239
<b>F8-6724</b>	<b>F8-7336</b>	<b>F8-7353</b>	<b>F8-7684</b>	<b>F8-7976</b>	<b>F8-8174</b>	<b>G8-544</b>
Ref.Nr.: 31120393540	Ref.Nr.: 31331094749	Ref.Nr.: 33321090504	Ref.Nr.: 1136283	Ref.Nr.: 33551138104	Ref.Nr.: 23711137817	Ref.Nr.: 3112677849
<b>G9-658</b>	<b>G9-658S</b>	<b>LM-10011S</b>	<b>LM-10012S</b>	<b>LM-10078S</b>		
Ref.Nr.: 31129068753	Ref.Nr.: 31129068753	Ref.Nr.: 31111137070	Ref.Nr.: 32131092876	Ref.Nr.: 32131096910		

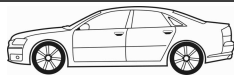
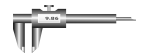
**Article Description****Article Nr.****Fitting Position**

<b>AVEO Hatchback (T200)</b>			<b>01/2005 → 05/2008</b>		
Control Arm-/Trailing Arm Bush	1.5	ch.033314→	<b>F8-8015</b>		d=12; L=47; D=28
<b>AVEO Saloon (T200)</b>			<b>09/2003 →</b>		
Dust Cover Kit, shock absorber	1.6		<b>AK-735095</b>		
Control Arm-/Trailing Arm Bush	1.6		<b>F8-8014</b>		H=46; d=12; D=60
Control Arm-/Trailing Arm Bush	1.6	ch.033314→	<b>F8-8015</b>		d=12; L=47; D=28
<b>AVEO Hatchback (T250, T255)</b>			<b>04/2008 →</b>		
Dust Cover Kit, shock absorber	1.2, 1.4		<b>AK-735095</b>		
Control Arm-/Trailing Arm Bush	1.2, 1.2 LPG, 1.4		<b>F8-8014</b>		H=46; d=12; D=60
Control Arm-/Trailing Arm Bush	1.2, 1.2 LPG, 1.4	ch.033314→	<b>F8-8015</b>		d=12; L=47; D=28
Stabiliser Mounting	1.4		<b>F8-8016</b>		d=16
<b>AVEO Saloon (T250, T255)</b>			<b>05/2005 → 12/2007</b>		
Dust Cover Kit, shock absorber	1.2, 1.2 LPG, 1.4, 1.5, 1.6		<b>AK-735095</b>		
Control Arm-/Trailing Arm Bush	1.2, 1.2 LPG, 1.4, 1.5, 1.6		<b>F8-8014</b>		H=46; d=12; D=60
Control Arm-/Trailing Arm Bush	1.2, 1.2 LPG, 1.4, 1.5, 1.6	ch.033314→	<b>F8-8015</b>		d=12; L=47; D=28
Stabiliser Mounting	1.4		<b>F8-8016</b>		d=16
Stabiliser Mounting	1.4	F14D3	<b>F8-8016</b>		d=16
<b>AVEO Hatchback (T300)</b>			<b>03/2011 →</b>		
Control Arm-/Trailing Arm Bush	1.2, 1.2 LPG, 1.3 D, 1.4, 1.6	ch.033314→	<b>F8-8015</b>		d=12; L=47; D=28
<b>AVEO Saloon (T300)</b>			<b>03/2011 →</b>		
Control Arm-/Trailing Arm Bush	1.2, 1.3 D, 1.4, 1.6	ch.033314→	<b>F8-8015</b>		d=12; L=47; D=28
<b>CAPTIVA (C100, C140)</b>			<b>10/2006 →</b>		
Alternator Freewheel Clutch	2.0 D, 2.0 D 4WD		<b>F5-1001</b>		
Bearing Bush, stabiliser	2.2 D 4WD		<b>F8-8218</b>		
<b>CRUZE</b>			<b>07/2000 → 09/2008</b>		
Control Arm-/Trailing Arm Bush	All Models		<b>F8-7857</b>		
Repair Kit, link	All Models		<b>F8-7857S</b>		
<b>CRUZE (J300)</b>			<b>05/2009 →</b>		
Top Strut Mounting	1.6, 1.6 T, 1.7 D, 1.8, 1.8 LPG, 2.0 CDI		<b>F8-7616</b>		H=49; D=114

<b>AK-735095</b>	<b>F5-1001</b>	<b>F8-7616</b>	<b>F8-7621</b>	<b>F8-7857</b>	<b>F8-7857S</b>	<b>F8-8014</b>
Ref.Nr.: 1J0512131B	Ref.Nr.: 211242	Ref.Nr.: 0344573	Ref.Nr.: 13251764	Ref.Nr.: 9209466	Ref.Nr.: 42451-76G00	Ref.Nr.: 96535088
<b>F8-8015</b>	<b>F8-8016</b>	<b>F8-8218</b>				
Ref.Nr.: 96535087	Ref.Nr.: 96653351	Ref.Nr.: 96297803				

Article Description



Article Nr.

Fitting Position



Article Description				Article Nr.	Fitting Position	
<b>CRUZE (J300)</b>				<b>05/2009</b> →		
Rubber Buffer, suspension	1.6, 1.8, 2.0 CDI	ST	F8-7621		H=270	
<b>CRUZE Hatchback (J305)</b>				<b>06/2011</b> →		
Top Strut Mounting	1.4, 1.6, 1.6 T, 1.7 D, 1.8, 1.8 LPG, 2.0 CDI	<b>SP</b> , <b>ST</b>	F8-7616		H=49; D=114	
Rubber Buffer, suspension	1.6, 1.8, 2.0 CDI	ST	F8-7621		H=270	
<b>CRUZE Station Wagon (J308)</b>				<b>08/2012</b> →		
Top Strut Mounting	1.4, 1.6, 1.6 T, 1.7 TD, 1.8, 2.0 TD	<b>SP</b> , <b>ST</b>	F8-7616		H=49; D=114	
<b>EPICA (KL1_)</b>				<b>01/2007</b> →		
Alternator Freewheel Clutch	2.0 D		F5-1001			
<b>IMPALA Saloon</b>				<b>01/1999</b> → <b>12/2005</b>		
Alternator Freewheel Clutch	3.8 V6		F5-1118			
<b>KALOS</b>				<b>03/2005</b> → <b>05/2008</b>		
Dust Cover Kit, shock absorber	1.2, 1.4, 1.4 16V		AK-735095			
Dust Cover Kit, shock absorber	1.2, 1.4, 1.4 16V		AK-735315			
Dust Cover Kit, shock absorber	1.2, 1.4, 1.4 16V		AK-735316			
Top Strut Mounting	1.2, 1.4, 1.4 16V		F8-7369			
Control Arm-/Trailing Arm Bush	All Models		F8-8014		H=46; d=12; D=60	
Control Arm-/Trailing Arm Bush	All Models	ch.690152→	F8-8015		d=12; L=47; D=28	
<b>KALOS Saloon</b>				<b>03/2005</b> →		
Dust Cover Kit, shock absorber	All Models		AK-735095			
Dust Cover Kit, shock absorber	1.4 16V		AK-735315			
Dust Cover Kit, shock absorber	1.4 16V		AK-735316			
Control Arm-/Trailing Arm Bush	All Models		F8-8014		H=46; d=12; D=60	
Control Arm-/Trailing Arm Bush	All Models	ch.690152→	F8-8015		d=12; L=47; D=28	
<b>LACETTI (J200)</b>				<b>03/2005</b> →		
Dust Cover Kit, shock absorber	1.4 16V, 1.6, 1.8		AK-735317			
Dust Cover Kit, shock absorber	1.4 16V, 1.6, 1.8		AK-735318			
Alternator Freewheel Clutch	2.0 D		F5-1001			
Control Arm-/Trailing Arm Bush	1.4 16V, 1.6, 1.8, 2.0 D		F8-7937			
Control Arm-/Trailing Arm Bush	1.4 16V, 1.6, 1.8, 2.0 D		F8-8219		H=60; d=12; D=39	
Bearing Bush, stabiliser	1.4 16V, 1.6, 1.8		F8-8220		d=17	

<b>AK-735095</b>	<b>AK-735315</b>	<b>AK-735316</b>	<b>AK-735317</b>	<b>AK-735318</b>	<b>F5-1001</b>	<b>F5-1118</b>
Ref.Nr.: 1J0512131B	Ref.Nr.: 96535006	Ref.Nr.: 96535162	Ref.Nr.: 96300082	Ref.Nr.: 96403109	Ref.Nr.: 211242	Ref.Nr.:
<b>F8-7369</b>	<b>F8-7616</b>	<b>F8-7621</b>	<b>F8-7937</b>	<b>F8-8014</b>	<b>F8-8015</b>	<b>F8-8219</b>
Ref.Nr.: 96456713	Ref.Nr.: 0344573	Ref.Nr.: 13251764	Ref.Nr.: 96391856	Ref.Nr.: 96535088	Ref.Nr.: 96535087	Ref.Nr.: 96378346
<b>F8-8220</b>						
Ref.Nr.: 96839848						

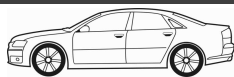
**Article Description****Article Nr.****Fitting Position**

<b>LACETTI Estate (J200)</b>			<b>03/2005 →</b>		
Dust Cover Kit, shock absorber	1.4, 1.6, 1.8, 2.0 D		<b>AK-735317</b>		
Control Arm-/Trailing Arm Bush	1.6		<b>F8-8219</b>		H=60; d=12; D=39
Bearing Bush, stabiliser	1.6		<b>F8-8220</b>		d=17
<b>MATIZ (M200, M250)</b>			<b>03/2005 →</b>		
Control Arm-/Trailing Arm Bush	0.8, 1.0		<b>F8-6585</b>		
Stabiliser Mounting	0.8, 0.8 LPG, 1.0, 1.0 LPG		<b>F8-7986</b>		
Stabiliser Mounting	0.8, 0.8 LPG, 1.0, 1.0 LPG		<b>F8-8013</b>		d=21
<b>NUBIRA Estate</b>			<b>01/2005 →</b>		
Alternator Freewheel Clutch	2.0, 2.0 D		<b>F5-1001</b>		
Control Arm-/Trailing Arm Bush	All Models		<b>F8-7937</b>		
Control Arm-/Trailing Arm Bush	All Models		<b>F8-8219</b>		H=60; d=12; D=39
Bearing Bush, stabiliser	1.6, 1.8, 2.0 D		<b>F8-8221</b>		d=18
<b>NUBIRA Saloon</b>			<b>01/2005 →</b>		
Alternator Freewheel Clutch	2.0, 2.0 D		<b>F5-1001</b>		
Control Arm-/Trailing Arm Bush	All Models		<b>F8-7937</b>		
Control Arm-/Trailing Arm Bush	1.4, 1.5, 1.6, 1.8, 2.0, 2.0 D		<b>F8-8219</b>		H=60; d=12; D=39
<b>OPTRA (1J_)</b>			<b>08/2003 → 12/2008</b>		
Control Arm-/Trailing Arm Bush	1.6, 1.8, 2.0		<b>F8-7937</b>		
<b>ORLANDO (J309)</b>			<b>02/2011 →</b>		
Rubber Buffer, suspension	1.4, 1.8, 2.0 D, 2.0 LPG	<b>ST</b>	<b>F8-7621</b>		H=270
<b>TACUMA</b>			<b>03/2005 →</b>		
Control Arm-/Trailing Arm Bush	1.6, 2.0		<b>F8-8219</b>		H=60; d=12; D=39
Bellow, steering	All Models	with clamps	<b>LM-10059S</b>		d1=13; d2=49; L [mm]=166
<b>SPARK</b>			<b>09/2000 → 12/2004</b>		
Stabiliser Mounting	0.8		<b>F8-7986</b>		
<b>SPARK</b>			<b>05/2005 →</b>		
Control Arm-/Trailing Arm Bush	0.8, 1.0 SX		<b>F8-6585</b>		
Stabiliser Mounting	0.8		<b>F8-7986</b>		

<b>AK-735317</b>	<b>F5-1001</b>	<b>F8-6585</b>	<b>F8-7621</b>	<b>F8-7937</b>	<b>F8-7986</b>	<b>F8-8013</b>
Ref.Nr.: 96300082	Ref.Nr.: 211242	Ref.Nr.: 96 380 613	Ref.Nr.: 13251764	Ref.Nr.: 96391856	Ref.Nr.: 96380586	Ref.Nr.: 96322618
<b>F8-8219</b>	<b>F8-8220</b>	<b>F8-8221</b>	<b>LM-10059S</b>			
Ref.Nr.: 96378346	Ref.Nr.: 96839848	Ref.Nr.: 96474041	Ref.Nr.: 520738			

Article Description

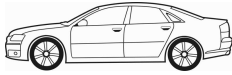

Article Nr.

Fitting  
Position



**TRAILBLAZER (KC\_)**

08/2005 → 12/2007

Alternator Freewheel Clutch	6.0 AWD		<b>F5-1069</b>		
-----------------------------	---------	--	----------------	--	--

**ZAFIRA (F75)**

04/2001 →

Alternator Freewheel Clutch	2.0		<b>F5-1028</b>		
-----------------------------	-----	--	----------------	--	--

<b>F5-1028</b>	<b>F5-1069</b>
Ref.Nr.:	Ref.Nr.:





Article Description				Article Nr.	Fitting Position	
<b>300 C (LX)</b>						09/2005 → 11/2012
Alternator Freewheel Clutch	3.0 CRD, 3.0 V6 CRD			F5-1126		
<b>300 C Touring (LX)</b>						09/2005 → 12/2010
Alternator Freewheel Clutch	3.0 CRD			F5-1126		
<b>LE BARON Saloon</b>						01/1989 → 12/1994
Repair Kit, suspension strut	All Models			F8-7356		
<b>LE BARON Convertible</b>						09/1986 → 12/1996
Repair Kit, suspension strut	All Models			F8-7356		
<b>LE BARON Coupe</b>						01/1990 → 12/1993
Repair Kit, suspension strut	All Models			F8-7356		
<b>NEON Mk II</b>						10/2001 → 12/2006
Control Arm-/Trailing Arm Bush	1.6, 2.0 16V, 2.0 16V R/T			F8-8228		
<b>PT CRUISER (PT_)</b>						06/2000 → 12/2010
Dust Cover Kit, shock absorber	1.6, 2.0, 2.2 CRD, 2.4, GT 2.4			AK-735321		
Dust Cover Kit, shock absorber	1.6, 2.0, 2.2 CRD, 2.4, GT 2.4			AK-735322		
Alternator Freewheel Clutch	2.2 CRD			F5-1019		
Control Arm-/Trailing Arm Bush	1.6, 2.0, 2.2 CRD, 2.4			F8-8228		
<b>PT CRUISER Convertible</b>						03/2004 → 03/2008
Dust Cover Kit, shock absorber	All Models			AK-735321		
Dust Cover Kit, shock absorber	All Models			AK-735322		
Control Arm-/Trailing Arm Bush	2.4			F8-8228		
<b>SEBRING (JS)</b>						07/2007 → 12/2010
Alternator Freewheel Clutch	2.4 VVT			F5-1078		
<b>VOYAGER (AS)</b>						10/1987 → 09/1990
Repair Kit, suspension strut	3.0, 3.3			F8-7356		
<b>VOYAGER II (ES)</b>						08/1990 → 09/1995
Dust Cover Kit, shock absorber	2.5 i, 2.5 TD, 3.0 i, 3.3 i, 3.3 i AWD			AK-735139		
Repair Kit, suspension strut	2.5 i, 2.5 TD, 3.0, 3.0 i, 3.3 i, 3.3 i AWD			F8-7356		
<b>VOYAGER Mk II (GS)</b>						01/1995 → 03/2001
Dust Cover Kit, shock absorber	2.0 i, 2.4 i, 2.5 TD, 3.0, 3.3 i, 3.8 i AWD			AK-735139		
<b>VOYAGER Mk III (RG, RS)</b>						02/2000 → 12/2008
Dust Cover Kit, shock absorber	2.4, 2.5 CRD, 2.8 CRD, 3.3, 3.3 AWD, 3.8, 3.8 AWD			AK-735323		

<b>AK-735139</b>	<b>AK-735321</b>	<b>AK-735322</b>	<b>AK-735323</b>	<b>AK-735324</b>	<b>F5-1019</b>	<b>F5-1078</b>
Ref.Nr.:	Ref.Nr.: 5272223AC	Ref.Nr.: 4656447AC	Ref.Nr.: 4684442AB	Ref.Nr.: 4684756AC	Ref.Nr.: 5117591AA	Ref.Nr.: 4891737AB
<b>F5-1126</b>	<b>F8-7356</b>	<b>F8-8228</b>				
Ref.Nr.: 05175811AA	Ref.Nr.: 4684006	Ref.Nr.: 4656012AB				

Article Description

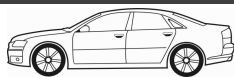

Article Nr.

Fitting Position



<b>VOYAGER Mk III (RG, RS)</b>		<b>02/2000 → 12/2008</b>	
Rubber Buffer, suspension	2.4, 2.5 CRD, 2.8 CRD, 3.3, 3.3 AWD, 3.8, 3.8 AWD	<b>AK-735324</b>	
Alternator Freewheel Clutch	2.5 CRD, 2.8 CRD	<b>F5-1107</b>	
<b>YPSILON</b>		<b>05/2011 →</b>	
Alternator Freewheel Clutch	1.3 Multijet	<b>F5-1041</b>	
<b>PACIFICA [USA] Sport Utility</b>		<b>01/2005 → 12/2007</b>	
Alternator Freewheel Clutch	3.8	<b>F5-1090</b>	

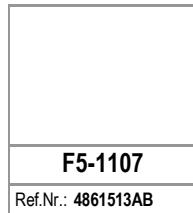
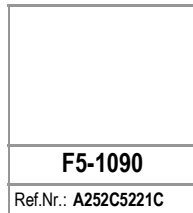

**Article Description****Article Nr.****Fitting Position**

AX (ZA-)		07/1986 → 12/1998	
Dust Cover Kit, shock absorber	10, 10 E, 11, 11 CAT, 14, 14 D, 15 D		<b>AK-735021</b>
Anti-Friction Bearing	1.3 Sport, 1.4 4x4, 1.4 Allure, 1.4 D 4x4, 1.4 GTi, 10, 10 E, 11 4x4, 11 CAT, 14, 14 D, 14 GT, 15 D, Electric		<b>F8-3012</b> H=20; d=66; D=100
Anti-Friction Bearing	11	H1A	<b>F8-3012</b> H=20; d=66; D=100
Anti-Friction Bearing	11	HDZ	<b>F8-3012</b> H=20; d=66; D=100
Anti-Friction Bearing	14	TU3FM	<b>F8-3012</b> H=20; d=66; D=100
Anti-Friction Bearing	14 4x4	KDZ	<b>F8-3012</b> H=20; d=66; D=100
Bellow, driveshaft	1.3 Sport, 1.4 GTi, 10, 10 E, 11, 11 CAT, 14, 14 4x4, 14 D, 15 D		<b>F8-5356</b> D1=72; D219; L=172
Engine Mounting	15 D		<b>F8-5358</b>
Top Strut Mounting	1.3 Sport, 1.4 4x4, 1.4 Allure, 1.4 GTi, 10, 10 E, 11, 11 4x4, 11 CAT, 14, 14 4x4, 14 D, 15 D		<b>F8-5519</b>
Engine Mounting	1.4 GTi, 11, 11 CAT, 14, 14 D, 15 D		<b>F8-5555</b>
Engine Mounting	10	Orga.04221→	<b>F8-5555</b>
Engine Mounting	14, 14 4x4	TU3FM	<b>F8-5555</b>
Engine Mounting	1.3 Sport, 10, 10 E, 11, 11 CAT, 14		<b>F8-5557</b>
Belt Pulley, crankshaft	15 D		<b>F8-5644</b>
Belt Pulley, crankshaft	15 D	ch.07666→	<b>F8-5644</b>
Mounting, axle beam	1.3 Sport, 1.4 4x4, 1.4 GTi, 14 4x4		<b>F8-5799</b> H=47; d=12; D=32
Stabiliser Mounting	1.3 Sport, 1.4 4x4, 1.4 Allure, 1.4 D 4x4, 1.4 GTi, 10, 10 E, 11, 11 4x4, 11 CAT, 14, 14 4x4, 14 D, 15 D, Electric	Orga.O 04803→; Stabi. Diam. [mm]= 19	<b>F8-6096</b> d=19
Control Arm-/Trailing Arm Bush	1.4 GTi		<b>F8-6143</b>
Control Arm-/Trailing Arm Bush	14	TU3M	<b>F8-6143</b>
Repair Kit, wheel suspension	1.3 Sport, 1.4 Allure, 1.4 GTi, 10, 10 E, 11, 11 4x4, 11 CAT, 14, 14 4x4, 14 D, 14 GT, 15 D, Electric		<b>F8-6274</b>
Repair Kit, wheel suspension	1.3 Sport, 1.4 Allure, 1.4 GTi, 10, 10 E, 11, 11 4x4, 11 CAT, 14, 14 4x4, 14 D, 14 GT, 15 D, Electric		<b>F8-6275</b>
Top Strut Mounting	1.3 Sport, 1.4 GTi, 10, 10 E, 11, 11 4x4, 11 CAT, 14, 14 4x4, 14 D, 15 D		<b>F8-6292</b>
Engine Mounting	1.3 Sport	Orga.4347→	<b>F8-6487</b>
Engine Mounting	1.4 4x4, 1.4 Allure, 1.4 D 4x4, 1.4 GTi, 11, 11 4x4, 11 CAT, 14, 14 4x4, 14 D		<b>F8-6487</b>
Engine Mounting	11	H1A	<b>F8-6487</b>
Stabiliser Mounting	1.3 Sport, 1.4 4x4, 10, 10 E, 11, 11 CAT, 14, 14 D		<b>F8-6792</b> d=19
Stabiliser Mounting	1.3 Sport, 10, 10 E, 11, 11 4x4, 11 CAT, 14, 14 4x4, 14 D, 15 D	Stabi. Diam. [mm]= 22	<b>F8-6794</b> d=22
Stabiliser Mounting	1.3 Sport, 10, 10 E, 11, 11 4x4, 11 CAT, 14, 14 4x4, 14 D, 15 D		<b>F8-6795</b> D=23; d=22



Article Description



Article Nr.

Fitting Position



AX (ZA-)			07/1986 → 12/1998		
Engine Mounting	1.3 Sport, 1.4 GTi, 10, 11, 14 D, 15 D		<b>F8-6904</b>		
Engine Mounting	14	TU3FM	<b>F8-6904</b>		
Engine Mounting	1.3 Sport, 1.4 GTi, 10, 11		<b>F8-6927</b>		
Engine Mounting	14, 14 4x4	TU3FM	<b>F8-6927</b>		
Engine Mounting	10, 11, 11 CAT		<b>F8-8199</b>		
Repair Kit, wheel suspension	1.3 Sport, 1.4 Allure, 1.4 GTi, 10, 10 E, 11, 11 4x4, 11 CAT, 14, 14 4x4, 14 D, 14 GT, 15 D, Electric		<b>G8-274</b>		
Repair Kit, wheel suspension	1.3 Sport, 1.4 Allure, 1.4 GTi, 10, 10 E, 11, 11 4x4, 11 CAT, 14, 14 4x4, 14 D, 14 GT, 15 D, Electric		<b>G8-275</b>		
Control Arm-/Trailing Arm Bush	1.3 Sport, 1.4 GTi, 10, 10 E, 11, 11 CAT, 14, 14 4x4, 14 D, 15 D		<b>G9-555</b>		H=46; d=17; W=55, 85
Control Arm-/Trailing Arm Bush	1.3 Sport, 10, 10 E, 11, 11 CAT, 14, 14 4x4, 14 D, 15 D		<b>G9-556</b>		H1=30; H2=49; d=12; D=34
Control Arm-/Trailing Arm Bush	10, 11, 14, 14 D	04/1991 →	<b>G9-556</b>		H1=30; H2=49; d=12; D=34
Control Arm-/Trailing Arm Bush	1.3 Sport, 1.4 GTi, 10, 10 E, 11, 11 CAT, 14, 14 4x4, 14 D, 15 D		<b>G9-558</b>		H=46; d=17; W=55, 87
Control Arm-/Trailing Arm Bush	1.3 Sport, 10, 10 E, 11, 11 CAT, 14, 14 D	for OE: 96 133 608	<b>G9-610</b>		
Bellow, steering	All Models		<b>LM-10014S</b>		d1=12; d2=40; L [mm]=106
Bellow, steering	1.3 Sport, 1.4 4x4, 1.4 Allure, 1.4 D 4x4, 1.4 GTi, 10, 10 E, 11, 11 4x4, 11 CAT, 14, 14 4x4, 14 D, 15 D, Electric	Orga.07119→; with clamps;	<b>LM-10047S</b>		d1=22; d2=45; L [mm]=120
Bellow, steering	14	; Orga.07084, 07119→; with clamps;	<b>LM-10047S</b>		d1=22; d2=45; L [mm]=120
Bellow, steering	14, 14 GT	; Orga.07084, 07119→; with clamps;	<b>LM-10047S</b>		d1=22; d2=45; L [mm]=120
Bellow, steering	10, 10 E, 11, 11 CAT, 14, 14 D, 15 D	with adapter, with clamps	<b>LM-10051S</b>		H=20; d=38; d1=17; d2=22; L [mm]=134
BERLINGO (MF)			07/1996 → 10/2005		
Dust Cover Kit, shock absorber	1.1 i, 1.4, 1.4 bivalent, 1.4 GNC, 1.4 i, 1.4 i bivalent, 1.6 16V, 1.6 HDI 110, 1.6 HDI 75, 1.6 HDI 90, 1.8 D, 1.8 i, 1.8 i 4WD, 1.9 D, 1.9 D 4WD, 2.0 HDI 90		<b>AK-735010</b>		
Alternator Freewheel Clutch	2.0 HDI 90		<b>F5-1020</b>		
Alternator Freewheel Clutch	1.6 HDI 110, 1.6 HDI 75, 1.6 HDI 90, 1.9 D, 1.9 D 4WD, 2.0 HDi 4x4, 2.0 HDI 90		<b>F5-1046</b>		
Alternator Freewheel Clutch	1.6 HDI 110, 1.6 HDI 75, 1.6 HDI 90, 1.9 D, 1.9 D 4WD		<b>F5-1048</b>		
Anti-Friction Bearing	1.1 i	TU1JP	<b>F8-3012</b>		H=20; d=66; D=100
Anti-Friction Bearing	1.4, 1.4 bivalent, 1.4 GNC, 1.4 Hybrid, 1.4 i, 1.4 i bivalent, 1.6 16V, 1.6 HDI 110, 1.6 HDI 75, 1.6 HDI 90, 1.8 D, 1.8 i, 1.8 i 4WD, 1.9 D, 2.0 HDi 4x4, 2.0 HDI 90, Electric, électrique		<b>F8-3012</b>		H=20; d=66; D=100

<b>AK-735010</b>	<b>F5-1020</b>	<b>F5-1046</b>	<b>F5-1048</b>	<b>F8-3012</b>	<b>F8-6904</b>	<b>F8-6927</b>
Ref.Nr.:	Ref.Nr.: 31771-68D01	Ref.Nr.: 30667687	Ref.Nr.: 77363468	Ref.Nr.: 503527	Ref.Nr.: 1844.54	Ref.Nr.: 96038337
<b>F8-8199</b>	<b>G8-274</b>	<b>G8-275</b>	<b>G9-555</b>	<b>G9-556</b>	<b>G9-558</b>	<b>G9-610</b>
Ref.Nr.: 184399	Ref.Nr.: 514858	Ref.Nr.: 5174.05	Ref.Nr.: 3523.51	Ref.Nr.: 95603308	Ref.Nr.: 352351	Ref.Nr.: 95603346
<b>LM-10014S</b>	<b>LM-10047S</b>	<b>LM-10051S</b>				
Ref.Nr.: 4066.32	Ref.Nr.: 4066.50	Ref.Nr.: 4066.34				

**Article Description****Article Nr.****Fitting Position**

<b>BERLINGO (MF)</b>		<b>07/1996 → 10/2005</b>	
Anti-Friction Bearing	1.9 D , 1.9 D 4WD	DW8	<b>F8-3012</b>
Stabiliser Mounting	1.4 i , 1.6 16V , 1.8 i , 1.8 i 4WD , 1.9 D , 1.9 D 4WD , 2.0 HDI 90 , électrique		<b>F8-5213</b>
Control Arm-/Trailing Arm Bush	1.1 i , 1.4 i , 1.6 16V , 1.8 D , 1.8 i , 1.8 i 4WD , 1.9 D , 1.9 D 4WD , 2.0 HDI 90 , électrique		<b>F8-5248</b>
Control Arm-/Trailing Arm Bush	1.1 i , 1.4 , 1.4 GNC , 1.4 i , 1.4 i bivalent , 1.6 16V , 1.8 D , 1.8 i , 1.8 i 4WD , 1.9 D , 1.9 D 4WD , Electric , électrique		<b>F8-5355</b>
Bellow, driveshaft	1.1 i , 1.4 i		<b>F8-5356</b> D1=72; D219; L=172
Engine Mounting	1.8 D , 1.9 D , 1.9 D 4WD , 2.0 HDi 4x4 , 2.0 HDI 90		<b>F8-5357</b>
Engine Mounting	1.8 i , 1.8 i 4WD		<b>F8-5358</b>
Control Arm-/Trailing Arm Bush	2.0 HDi 4x4 , 2.0 HDI 90		<b>F8-5361</b>
Engine Mounting	1.1 i , 1.4 i , 2.0 HDi 4x4		<b>F8-5375</b> H=34; d=12; D=30
Top Strut Mounting	1.1 i , 1.4 i , 1.4 i bivalent , 1.6 16V , 1.8 D , 1.8 i , 1.8 i 4WD , 1.9 D , 1.9 D 4WD , 2.0 HDI 90 , électrique		<b>F8-5516</b>
Top Strut Mounting	1.1 i , 1.4 i , 1.4 i bivalent , 1.6 16V , 1.8 D , 1.8 i , 1.8 i 4WD , 1.9 D , 1.9 D 4WD , 2.0 HDI 90		<b>F8-5517</b>
Engine Mounting	1.1 i	TU1M	<b>F8-5568</b>
Engine Mounting	1.4 i , 1.6 16V , 1.8 D , 1.8 i , 1.8 i 4WD , 1.9 D , 2.0 HDI 90		<b>F8-5568</b>
Belt Pulley, crankshaft	1.9 D , 2.0 HDI 90		<b>F8-5636</b> d=30
Belt Pulley, crankshaft	1.9 D 4WD	DW8; Orga.09377→;	<b>F8-5636</b> d=30
Belt Pulley, crankshaft	2.0 HDi 4x4	Orga.→10179	<b>F8-5636</b> d=30
Belt Pulley, crankshaft	1.8 D , 1.9 D	Number of Ribs: 6	<b>F8-5643</b> Belt Pulley Ø [mm]=156; W=44
Belt Pulley, crankshaft	1.9 D		<b>F8-5659</b>
Belt Pulley, crankshaft	1.9 D 4WD	DW8	<b>F8-5659</b>
Belt Pulley, crankshaft	1.9 D	09/2004 →;  DW8B; Orga.10178→;	<b>F8-5660</b>
Belt Pulley, crankshaft	2.0 HDi 4x4	Orga.10180→	<b>F8-5660</b>
Mounting, axle beam	1.4 i , 1.6 16V , 1.8 i , 1.9 D , 2.0 HDI 90		<b>F8-5852</b> H=30; D=11.5
Stabiliser Mounting	1.1 i	TU1JP	<b>F8-6128</b> d=22
Stabiliser Mounting	1.4 , 1.4 GNC , 1.4 i , 1.6 16V , 1.6 HDI 110 , 1.6 HDI 75 , 1.6 HDI 90 , 1.8 D , 1.8 i , 1.8 i 4WD , 1.9 D , 2.0 HDI 4x4 , 2.0 HDI 90 , Electric , électrique		<b>F8-6128</b> d=22
Stabiliser Mounting	1.9 D 4WD	DW8	<b>F8-6128</b> d=22
Mounting, axle beam	1.1 i , 1.4 , 1.4 GNC , 1.4 i , 1.6 16V , 1.6 HDI 110 , 1.6 HDI 75 , 1.6 HDI 90 , 1.8 D , 1.8 i , 1.8 i 4WD , 1.9 D , 1.9 D 4WD , 2.0 HDi 4x4 , 2.0 HDI 90 , Electric , électrique		<b>F8-6176</b>

<b>F8-3012</b>	<b>F8-5213</b>	<b>F8-5248</b>	<b>F8-5355</b>	<b>F8-5356</b>	<b>F8-5357</b>	<b>F8-5358</b>
Ref.Nr.: 503527	Ref.Nr.: 5094.65	Ref.Nr.: 3523.59	Ref.Nr.: 3520.H5S1	Ref.Nr.: 328769	Ref.Nr.: 1844.47	Ref.Nr.: 184373
<b>F8-5361</b>	<b>F8-5375</b>	<b>F8-5516</b>	<b>F8-5517</b>	<b>F8-5568</b>	<b>F8-5636</b>	<b>F8-5643</b>
Ref.Nr.: 3523.83	Ref.Nr.: 180906	Ref.Nr.: 503824	Ref.Nr.: 5038.23	Ref.Nr.: 184425	Ref.Nr.: 0515P2	Ref.Nr.: 96089 38980
<b>F8-5659</b>	<b>F8-5660</b>	<b>F8-5852</b>	<b>F8-6128</b>	<b>F8-6176</b>	<b>F8-6236</b>	
Ref.Nr.: 0515Q6	Ref.Nr.: 0515R9	Ref.Nr.: 5131.47	Ref.Nr.: 5094.77	Ref.Nr.: 515262	Ref.Nr.: 1809.21	

Article Description



Article Nr.

Fitting Position



<b>BERLINGO (MF)</b>		<b>07/1996 → 10/2005</b>		
Engine Mounting	1.8 D , 1.8 i , 1.8 i 4WD , 1.9 D , 1.9 D 4WD , 2.0 HDi 4x4 , 2.0 HDi 90		F8-6236	H1=53; H2=40; d=10; D=70
Engine Mounting	1.8 D , 1.8 i , 1.8 i 4WD , 1.9 D , 1.9 D 4WD , 2.0 HDi 4x4 , 2.0 HDi 90		F8-6237	
Repair Kit, wheel suspension	1.1 i , 1.4 bivalent , 1.4 Hybrid , 1.4 i , 1.4 i bivalent , 1.6 16V , 1.6 HDi 110 , 1.6 HDi 75 , 1.6 HDi 90 , 1.8 D , 1.8 i , 1.8 i 4WD , 1.9 D , 1.9 D 4WD , 2.0 HDi 4x4 , 2.0 HDi 90 , Electric, électrique		F8-6276	
Top Strut Mounting	1.1 i , 1.4 bivalent , 1.4 i , 1.4 i bivalent , 1.6 16V , 1.6 HDi 75 , 1.6 HDi 90 , 1.8 D , 1.8 i , 1.8 i 4WD , 1.9 D , 1.9 D 4WD , 2.0 HDi 90 , électrique		F8-6296	
Top Strut Mounting	1.1 i , 1.4 bivalent , 1.4 i , 1.4 i bivalent , 1.6 16V , 1.6 HDi 75 , 1.6 HDi 90 , 1.8 D , 1.8 i , 1.8 i 4WD , 1.9 D , 1.9 D 4WD , 2.0 HDi 90		F8-6297	
Belt Pulley, crankshaft	1.4 , 1.4 GNC , 1.4 i bivalent , 1.6 16V	Number of Ribs: 5; Parameter: 6PK	F8-6394	H=25; d=44.05; Mounting points diam.[mm]=9; D=148; D1=142.9
Engine Mounting	1.9 D , 2.0 HDi 90	11/2002 →	F8-6486	
Engine Mounting	2.0 HDi 4x4		F8-6486	
Engine Mounting	1.1 i	TU1JP	F8-6487	
Engine Mounting	1.4 i		F8-6487	
Engine Mounting	1.6 16V , 1.6 HDi 75 , 1.6 HDi 90		F8-6497	
Engine Mounting	1.6 16V , 1.6 HDi 90 , 1.8 i , 1.8 i 4WD , 1.9 D , 2.0 HDi 4x4 , 2.0 HDi 90		F8-6500	
Engine Mounting	1.6 HDi 75	DV6B	F8-6500	
Engine Mounting	1.8 D	XUD7	F8-6500	
Engine Mounting	1.9 D 4WD	DW8 , DW8B	F8-6500	
Mounting, automatic transmission	1.1 i	TU1JP	F8-6505	
Mounting, automatic transmission	1.4 i		F8-6505	
Belt Pulley, crankshaft	1.6 HDi 90	Number of Ribs: 6; Orga. → 10562	F8-7082	Belt Pulley Ø [mm]=152; Mounting points diam.[mm]=30; W=34
Rubber Buffer, suspension	1.1 i , 1.4 i , 1.6 16V , 1.8 D , 1.8 i , 1.8 i 4WD , 1.9 D , 1.9 D 4WD , 2.0 HDi 90 , électrique	Orga. → 09799	F8-7589	H=81
Rubber Buffer, suspension	1.1 i , 1.4 , 1.4 GNC , 1.4 i , 1.6 16V , 1.6 HDi 110 , 1.6 HDi 75 , 1.6 HDi 90 , 1.8 D , 1.8 i , 1.8 i 4WD , 1.9 D , 1.9 D 4WD , 2.0 HDi 4x4 , 2.0 HDi 90 , Electric, électrique	Orga. 09800 →	F8-7590	H=94
Belt Pulley, crankshaft	1.6 16V	Number of Ribs: 4; Parameter: 5PK	F8-7643	D=128
Belt Pulley, crankshaft	1.6 HDi 75	Number of Ribs: 5; Parameter: 6PK	F8-7645	D=157.75
Belt Pulley, crankshaft	1.6 HDi 90	Number of Ribs: 5; Orga. 10563 →; Parameter: 6PK	F8-7645	D=157.75



**Article Description****Article Nr.****Fitting Position****BERLINGO (MF)****07/1996 → 10/2005**

Belt Pulley, crankshaft	1.9 D	DW8; Orga.09895→;	<b>F8-7862</b>		
Belt Pulley, crankshaft	1.9 D	DW8B; Orga.09905→;	<b>F8-7862</b>		
Stabiliser Mounting	1.1 i, 1.4 bivalent, 1.4 i, 1.4 i bivalent, 1.6 16V, 1.6 HDI 75, 1.6 HDI 90, 1.8 D, 1.8 i, 1.8 i 4WD, 1.9 D, 1.9 D 4WD, 2.0 HDI 90, électrique		<b>F8-7943</b>		
Engine Mounting	1.6 HDI 75, 1.6 HDI 90		<b>F8-8184</b>		
Repair Kit, wheel suspension	All Models		<b>G8-276-5017</b>		H=197; d=34; D=50,17
Repair Kit, wheel suspension	All Models		<b>G8-276-5020</b>		H=197; d=34; D=50,2
Bellow, steering	1.1 i, 1.4, 1.4 bivalent, 1.4 GNC, 1.4 Hybrid, 1.4 i, 1.4 i bivalent, 1.6 16V, 1.6 HDI 110, 1.6 HDI 75, 1.6 HDI 90, 1.8 D, 1.8 i, 1.8 i 4WD, 1.9 D, 1.9 D 4WD, 2.0 HDi 4x4, 2.0 HDI 90, Electric, électrique	; with clamps;	<b>LM-10004S</b>		d1=10; d2=40; L [mm]=175
Bellow, steering	1.1 i, 1.4, 1.4 bivalent, 1.4 GNC, 1.4 Hybrid, 1.4 i, 1.4 i bivalent, 1.6 16V, 1.6 HDI 110, 1.6 HDI 75, 1.6 HDI 90, 1.8 D, 1.8 i, 1.8 i 4WD, 1.9 D, 1.9 D 4WD, 2.0 HDi 4x4, 2.0 HDI 90, Electric, électrique	; with clamps	<b>LM-10004S</b>		d1=10; d2=40; L [mm]=175
Bellow, steering	1.1 i, 1.4, 1.4 bivalent, 1.4 GNC, 1.4 i, 1.4 i bivalent, 1.6 16V, 1.6 HDI 75, 1.6 HDI 90, 1.8 D, 1.8 i, 1.8 i 4WD, 1.9 D, 1.9 D 4WD, 2.0 HDi 4x4, 2.0 HDI 90	with clamps	<b>LM-10039S</b>		d1=40; d2=40; L [mm]=115
Bellow, steering	1.1 i, 1.4 bivalent, 1.4 i, 1.4 i bivalent, 1.6 16V, 1.6 HDI 75, 1.6 HDI 90, 1.8 D, 1.8 i, 1.8 i 4WD, 1.9 D, 1.9 D 4WD	with clamps;	<b>LM-10058S</b>		d1=11; d2=42; L [mm]=150
Bellow, steering	2.0 HDI 90	with clamps;	<b>LM-10058S</b>		d1=11; d2=42; L [mm]=150

**BERLINGO Box (M\_)****07/1996 → 12/2007**

Dust Cover Kit, shock absorber	1.1 i, 1.4 bivalent, 1.4 i, 1.4 i bivalent, 1.6 16V, 1.6 HDI 75, 1.8 D, 1.8 i, 1.9 D, 1.9 D 70, 1.9 D 70 4WD, 2.0 HDI 90, 2.0 HDI 90 4WD		<b>AK-735010</b>		
Alternator Freewheel Clutch	1.6 HDI 75, 1.6 HDI 90, 1.9 D 70, 1.9 D 70 4WD, 2.0 HDI 90, 2.0 HDI 90 4WD		<b>F5-1046</b>		
Alternator Freewheel Clutch	1.6 HDI 75, 1.6 HDI 90, 1.9 D 70, 1.9 D 70 4WD		<b>F5-1048</b>		
Anti-Friction Bearing	1.1 i	TU1M	<b>F8-3012</b>		H=20; d=66; D=100
Anti-Friction Bearing	1.4, 1.4 bivalent, 1.4 i, 1.4 i bivalent, 1.6 16V, 1.6 HDI 75, 1.6 HDI 90, 1.8 D, 1.8 i, 1.9 D, 1.9 D 70 4WD, 2.0 HDI 90, 2.0 HDI 90 4WD, Electric		<b>F8-3012</b>		H=20; d=66; D=100
Anti-Friction Bearing	1.9 D 70	DW8	<b>F8-3012</b>		H=20; d=66; D=100
Stabiliser Mounting	1.1 i, 1.4 i, 1.4 i bivalent, 1.8 D, 1.9 D, 1.9 D 70, 1.9 D 70 4WD, 2.0 HDI 90		<b>F8-5213</b>		d=21
Control Arm-/Trailing Arm Bush	1.1 i, 1.4 i, 1.4 i bivalent, 1.6 16V, 1.8 D, 1.8 i, 1.9 D, 1.9 D 70, 1.9 D 70 4WD, 2.0 HDI 90		<b>F8-5248</b>		
Control Arm-/Trailing Arm Bush	1.1 i, 1.4, 1.4 i, 1.4 i bivalent, 1.6 16V, 1.8 D, 1.8 i, 1.9 D, 1.9 D 70, 1.9 D 70 4WD, Electric		<b>F8-5355</b>		

<b>AK-735010</b>	<b>F5-1046</b>	<b>F5-1048</b>	<b>F8-3012</b>	<b>F8-5213</b>	<b>F8-5248</b>	<b>F8-5355</b>
Ref.Nr.:	Ref.Nr.: 30667687	Ref.Nr.: 77363468	Ref.Nr.: 503527	Ref.Nr.: 5094.65	Ref.Nr.: 3523.59	Ref.Nr.: 3520.H5S1
<b>F8-5356</b>	<b>F8-7862</b>	<b>F8-7943</b>		<b>G8-276-5017</b>	<b>G8-276-5020</b>	<b>LM-10004S</b>
Ref.Nr.: 328769	Ref.Nr.: 0515 R5	Ref.Nr.: 509479	Ref.Nr.: 1806.33	Ref.Nr.: 5132.73	Ref.Nr.: 514851	Ref.Nr.: 7910030073
<b>LM-10039S</b>	<b>LM-10058S</b>					
Ref.Nr.: 4066.22	Ref.Nr.: 4066.43					

Article Description



Article Nr.

Fitting Position



**BERLINGO Box (M\_)**

07/1996 → 12/2007

Bellow, driveshaft	1.1 i, 1.4 i		<b>F8-5356</b>		D1=72; D219; L=172
Engine Mounting	1.8 D, 1.9 D, 1.9 D 70, 1.9 D 70 4WD, 2.0 HDI 90, 2.0 HDI 90 4WD		<b>F8-5357</b>		
Engine Mounting	1.8 i		<b>F8-5358</b>		
Control Arm-/Trailing Arm Bush	2.0 HDI 90, 2.0 HDI 90 4WD		<b>F8-5361</b>		
Engine Mounting	1.1 i, 1.4 i, 2.0 HDI 90, 2.0 HDI 90 4WD		<b>F8-5375</b>		H=34; d=12; D=30
Top Strut Mounting	1.1 i, 1.4 i, 1.4 i bivalent, 1.8 D, 1.9 D, 1.9 D 70, 1.9 D 70 4WD, 2.0 HDI 90		<b>F8-5516</b>		
Top Strut Mounting	1.1 i, 1.4 i, 1.4 i bivalent, 1.8 D, 1.9 D, 1.9 D 70, 1.9 D 70 4WD, 2.0 HDI 90		<b>F8-5517</b>		
Engine Mounting	1.1 i, 1.4 i, 1.8 D, 1.9 D, 1.9 D 70, 1.9 D 70 4WD, 2.0 HDI 90		<b>F8-5568</b>		
Belt Pulley, crankshaft	1.9 D 70	DW8; Orga.09377→	<b>F8-5636</b>		d=30
Belt Pulley, crankshaft	1.9 D 70 4WD	Orga.09377→	<b>F8-5636</b>		d=30
Belt Pulley, crankshaft	2.0 HDI 90		<b>F8-5636</b>		d=30
Belt Pulley, crankshaft	2.0 HDI 90 4WD	Orga.→10179	<b>F8-5636</b>		d=30
Belt Pulley, crankshaft	1.8 D, 1.9 D	Number of Ribs: 6	<b>F8-5643</b>		Belt Pulley Ø [mm]=156; W=44
Belt Pulley, crankshaft	1.9 D 70	DW8	<b>F8-5659</b>		
Belt Pulley, crankshaft	1.9 D 70 4WD		<b>F8-5659</b>		
Belt Pulley, crankshaft	1.9 D 70	09/2004 →;  DW8B; Orga.10178→;	<b>F8-5660</b>		
Belt Pulley, crankshaft	1.9 D 70 4WD	09/2004 →; Orga.10178→;	<b>F8-5660</b>		
Belt Pulley, crankshaft	2.0 HDI 90, 2.0 HDI 90 4WD	Orga.10180→	<b>F8-5660</b>		
Mounting, axle beam	1.1 i, 1.4 i, 1.4 i bivalent, 1.8 D, 1.9 D, 1.9 D 70, 2.0 HDI 90		<b>F8-5852</b>		H=30; D=11.5
Stabiliser Mounting	1.1 i, 1.4, 1.4 i, 1.4 i bivalent, 1.6 16V, 1.6 HDI 75, 1.6 HDI 90, 1.8 D, 1.8 i, 1.9 D, 1.9 D 70, 1.9 D 70 4WD, 2.0 HDI 90, 2.0 HDI 90 4WD, Electric		<b>F8-6128</b>		d=22
Mounting, axle beam	1.1 i, 1.4, 1.4 i, 1.4 i bivalent, 1.6 16V, 1.6 HDI 75, 1.6 HDI 90, 1.8 D, 1.8 i, 1.9 D, 1.9 D 70, 1.9 D 70 4WD, 2.0 HDI 90, 2.0 HDI 90 4WD, Electric		<b>F8-6176</b>		
Engine Mounting	1.8 D, 1.8 i, 1.9 D, 1.9 D 70, 1.9 D 70 4WD, 2.0 HDI 90, 2.0 HDI 90 4WD		<b>F8-6236</b>		H1=53; H2=40; d=10; D=70
Engine Mounting	1.8 D, 1.8 i, 1.9 D, 1.9 D 70, 1.9 D 70 4WD, 2.0 HDI 90, 2.0 HDI 90 4WD		<b>F8-6237</b>		
Repair Kit, wheel suspension	1.1 i, 1.4 bivalent, 1.4 i, 1.4 i bivalent, 1.6 16V, 1.6 HDI 75, 1.6 HDI 90, 1.8 D, 1.8 i, 1.9 D, 1.9 D 70, 1.9 D 70 4WD, 2.0 HDI 90, 2.0 HDI 90 4WD, Electric		<b>F8-6276</b>		
Top Strut Mounting	1.1 i	[kg]: 600;	<b>F8-6296</b>		





**Article Description****Article Nr.****Fitting Position**

<b>BERLINGO Box (M_)</b>		<b>07/1996 → 12/2007</b>	
Top Strut Mounting	1.4 bivalent, 1.4 i, 1.4 i bivalent, 1.6 16V, 1.6 HDI 75, 1.8 D, 1.8 i, 1.9 D, 1.9 D 70, 1.9 D 70 4WD, 2.0 HDI 90, 2.0 HDI 90 4WD		<b>F8-6296</b>
Top Strut Mounting	1.1 i	[kg]: 600;	<b>F8-6297</b>
Top Strut Mounting	1.4 i, 1.6 16V, 1.8 D, 1.8 i, 1.9 D, 1.9 D 70, 1.9 D 70 4WD		<b>F8-6297</b>
Belt Pulley, crankshaft	1.1 i, 1.4 bivalent, 1.4 i, 1.4 i bivalent, 1.6 16V	Number of Ribs: 5; Parameter: 6PK	<b>F8-6394</b>
Engine Mounting	2.0 HDI 90, 2.0 HDI 90 4WD	11/2002 →	<b>F8-6486</b>
Engine Mounting	1.1 i, 1.4 i, 1.4 i bivalent		<b>F8-6487</b>
Engine Mounting	1.6 16V, 1.6 HDI 75, 1.6 HDI 90		<b>F8-6497</b>
Engine Mounting	1.6 16V, 1.6 HDI 90, 1.8 D, 1.8 i, 1.9 D 70 4WD, 2.0 HDI 90, 2.0 HDI 90 4WD		<b>F8-6500</b>
Engine Mounting	1.6 HDI 75	DV6B	<b>F8-6500</b>
Engine Mounting	1.9 D 70	DW8, DW8B	<b>F8-6500</b>
Mounting, automatic transmission	1.1 i, 1.4 i, 1.4 i bivalent		<b>F8-6505</b>
Belt Pulley, crankshaft	1.6 HDI 90	Number of Ribs: 6; Orga.→10562	<b>F8-7082</b>
Rubber Buffer, suspension	1.1 i, 1.4 i, 1.6 16V, 1.8 D, 1.8 i, 1.9 D, 1.9 D 70, 1.9 D 70 4WD, 2.0 HDI 90	Orga.→09799	<b>F8-7589</b>
Rubber Buffer, suspension	1.1 i, 1.4, 1.4 i, 1.4 i bivalent, 1.6 16V, 1.6 HDI 75, 1.6 HDI 90, 1.8 D, 1.8 i, 1.9 D, 1.9 D 70, 1.9 D 70 4WD, 2.0 HDI 90, 2.0 HDI 90 4WD, Electric	Orga.09800→	<b>F8-7590</b>
Belt Pulley, crankshaft	1.6 16V	Number of Ribs: 4; Parameter: 5PK	<b>F8-7643</b>
Belt Pulley, crankshaft	1.6 HDI 75	Number of Ribs: 5; Parameter: 6PK	<b>F8-7645</b>
Belt Pulley, crankshaft	1.6 HDI 90	Number of Ribs: 5; Orga.10563→; Parameter: 6PK	<b>F8-7645</b>
Belt Pulley, crankshaft	1.9 D 70	DW8; Orga.09895→;	<b>F8-7862</b>
Belt Pulley, crankshaft	1.9 D 70	DW8B; Orga.09905→;	<b>F8-7862</b>
Stabiliser Mounting	1.1 i, 1.4 bivalent, 1.4 i, 1.4 i bivalent, 1.8 D, 1.8 i, 1.9 D, 1.9 D 70, 1.9 D 70 4WD, 2.0 HDI 90, 2.0 HDI 90 4WD		<b>F8-7943</b>
Engine Mounting	1.6 HDI 75		<b>F8-8184</b>
Repair Kit, wheel suspension	All Models		<b>G8-276-5017</b>
Repair Kit, wheel suspension	All Models		<b>G8-276-5020</b>

<b>F8-6296</b>	<b>F8-6297</b>	<b>F8-6394</b>	<b>F8-6486</b>	<b>F8-6487</b>	<b>F8-6497</b>	<b>F8-6500</b>
Ref.Nr.: 503824	Ref.Nr.: 503527	Ref.Nr.: 0515.R8	Ref.Nr.: 1844.77	Ref.Nr.: 184472	Ref.Nr.: 1844.75	Ref.Nr.: 1844.36
<b>F8-6505</b>	<b>F8-7082</b>	<b>F8-7589</b>	<b>F8-7590</b>	<b>F8-7643</b>	<b>F8-7645</b>	<b>F8-7862</b>
Ref.Nr.: 1844.51	Ref.Nr.: 0515.R0	Ref.Nr.: 9621916980	Ref.Nr.: 5166.73	Ref.Nr.: 0515.J3	Ref.Nr.: 0515.T3	Ref.Nr.: 0515 R5
<b>F8-7943</b>	<b>F8-8184</b>	<b>G8-276-5017</b>	<b>G8-276-5020</b>	<b>LM-10004S</b>		
Ref.Nr.: 509479	Ref.Nr.: 1806.33	Ref.Nr.: 5132.73	Ref.Nr.: 514851	Ref.Nr.: 7910030073		

Article Description



Article Nr.

Fitting Position



<b>BERLINGO Box (M_)</b>				<b>07/1996 → 12/2007</b>	
Bellow, steering	1.1 i, 1.4, 1.4 bivalent, 1.4 i, 1.4 i bivalent, 1.6 16V, 1.6 HDi 75, 1.6 HDi 90, 1.8 D, 1.8 i, 1.9 D, 1.9 D 70, 1.9 D 70 4WD, 2.0 HDi 90, 2.0 HDi 90 4WD, Electric	; with clamps;	<b>LM-10004S</b>		d1=10; d2=40; L [mm]=175
Bellow, steering	1.1 i, 1.4, 1.4 bivalent, 1.4 i, 1.4 i bivalent, 1.6 16V, 1.6 HDi 75, 1.6 HDi 90, 1.8 D, 1.8 i, 1.9 D, 1.9 D 70, 1.9 D 70 4WD, 2.0 HDi 90, 2.0 HDi 90 4WD, Electric	; with clamps	<b>LM-10004S</b>		d1=10; d2=40; L [mm]=175
Bellow, steering	1.1 i, 1.4 i, 1.6 16V, 1.8 D, 1.8 i, 1.9 D, 1.9 D 70, 1.9 D 70 4WD, 2.0 HDi 90, 2.0 HDi 90 4WD	with clamps	<b>LM-10039S</b>		d1=40; d2=40; L [mm]=115
Bellow, steering	1.1 i, 1.4 bivalent, 1.4 i, 1.4 i bivalent, 1.8 D, 1.8 i, 1.9 D, 1.9 D 70, 1.9 D 70 4WD	with clamps;	<b>LM-10058S</b>		d1=11; d2=42; L [mm]=150
Bellow, steering	2.0 HDi 90	with clamps;	<b>LM-10058S</b>		d1=11; d2=42; L [mm]=150
<b>BERLINGO (B9)</b>				<b>04/2008 →</b>	
Alternator Freewheel Clutch	1.6 HDi 110, 1.6 HDi 75, 1.6 HDi 90		<b>F5-1046</b>		
Alternator Freewheel Clutch	1.6 HDi 110, 1.6 HDi 75, 1.6 HDi 90		<b>F5-1048</b>		
Alternator Freewheel Clutch	1.6 VTi 120, 1.6 VTi 95		<b>F5-1113</b>		
Alternator Freewheel Clutch	1.6 VTi 120, 1.6 VTi 95		<b>F5-1132</b>		
Anti-Friction Bearing	1.4, 1.6, 1.6 HDi 110, 1.6 HDi 115, 1.6 HDi 75, 1.6 HDi 90, 1.6 VTi 120, 1.6 VTi 95		<b>F8-3012</b>		H=20; d=66; D=100
Top Strut Mounting	1.4, 1.6, 1.6 HDi 110, 1.6 HDi 115, 1.6 HDi 75, 1.6 HDi 90, 1.6 VTi 120, 1.6 VTi 95		<b>F8-6058</b>		
Repair Kit, wheel suspension	1.4, 1.6, 1.6 HDi 110, 1.6 HDi 115, 1.6 HDi 75, 1.6 HDi 90, 1.6 VTi 120, 1.6 VTi 95		<b>F8-6276</b>		
Top Strut Mounting	1.4, 1.6, 1.6 HDi 110, 1.6 HDi 115, 1.6 HDi 75, 1.6 HDi 90, 1.6 VTi 120, 1.6 VTi 95		<b>F8-6302</b>		
Belt Pulley, crankshaft	1.6	Number of Ribs: 5; Parameter: 6PK	<b>F8-6394</b>		H=25; d=44.05; Mounting points diam.[mm]=9; D=148; D1=142.9
Engine Mounting	1.6, 1.6 HDi 90		<b>F8-6497</b>		
Engine Mounting	1.6, 1.6 HDi 90		<b>F8-6500</b>		
Mounting, automatic transmission	1.6, 1.6 HDi 110, 1.6 HDi 75, 1.6 HDi 90		<b>F8-6505</b>		
Rubber Buffer, suspension	1.4, 1.6, 1.6 HDi 110, 1.6 HDi 115, 1.6 HDi 75, 1.6 HDi 90, 1.6 VTi 120, 1.6 VTi 95		<b>F8-7585</b>		H=96
Belt Pulley, crankshaft	1.6 HDi 110, 1.6 HDi 75, 1.6 HDi 90	Number of Ribs: 5; Parameter: 6PK	<b>F8-7645</b>		D=157.75
Repair Kit, wheel suspension	1.4, 1.6, 1.6 HDi 110, 1.6 HDi 115, 1.6 HDi 75, 1.6 HDi 90, 1.6 VTi 120, 1.6 VTi 95		<b>G8-276-5017</b>		H=197; d=34; D=50,17
Repair Kit, wheel suspension	1.4, 1.6, 1.6 HDi 110, 1.6 HDi 115, 1.6 HDi 75, 1.6 HDi 90, 1.6 VTi 120, 1.6 VTi 95		<b>G8-276-5020</b>		H=197; d=34; D=50,2
<b>BERLINGO Box (B9)</b>				<b>04/2008 →</b>	
Alternator Freewheel Clutch	1.6 HDi 110, 1.6 HDi 75, 1.6 HDi 90		<b>F5-1046</b>		

<b>F5-1046</b>	<b>F5-1048</b>	<b>F5-1113</b>	<b>F5-1132</b>	<b>F8-3012</b>	<b>F8-6058</b>	<b>F8-6276</b>
Ref.Nr.: 30667687	Ref.Nr.: 77363468	Ref.Nr.: 12317576515	Ref.Nr.:	Ref.Nr.: 503527	Ref.Nr.: 5038.F7	Ref.Nr.: 9612314280
<b>F8-6302</b>	<b>F8-6394</b>	<b>F8-6497</b>	<b>F8-6500</b>	<b>F8-6505</b>	<b>F8-7585</b>	<b>F8-7645</b>
Ref.Nr.: 503885	Ref.Nr.: 0515.R8	Ref.Nr.: 1844.75	Ref.Nr.: 1844.36	Ref.Nr.: 1844.51	Ref.Nr.: 5033.70	Ref.Nr.: 0515.T3
<b>G8-276-5017</b>	<b>G8-276-5020</b>	<b>LM-10004S</b>	<b>LM-10039S</b>	<b>LM-10058S</b>		
Ref.Nr.: 5132.73	Ref.Nr.: 514851	Ref.Nr.: 7910030073	Ref.Nr.: 4066.22	Ref.Nr.: 4066.43		

**Article Description****Article Nr.****Fitting Position****BERLINGO Box (B9)****04/2008 →**

Alternator Freewheel Clutch	1.6 HDi 110, 1.6 HDi 75, 1.6 HDi 90		<b>F5-1048</b>		
Alternator Freewheel Clutch	1.6 VTi 120, 1.6 VTi 95		<b>F5-1113</b>		
Alternator Freewheel Clutch	1.6 VTi 120, 1.6 VTi 95		<b>F5-1132</b>		
Anti-Friction Bearing	1.6, 1.6 HDi 110, 1.6 HDi 115, 1.6 HDi 75, 1.6 HDi 90, 1.6 VTi 95		<b>F8-3012</b>		H=20; d=66; D=100
Top Strut Mounting	1.6, 1.6 HDi 110, 1.6 HDi 115, 1.6 HDi 75, 1.6 HDi 90, 1.6 VTi 95		<b>F8-6058</b>		
Repair Kit, wheel suspension	1.6 HDi 75, 1.6 HDi 90		<b>F8-6276</b>		
Top Strut Mounting	1.6, 1.6 HDi 110, 1.6 HDi 115, 1.6 HDi 75, 1.6 HDi 90, 1.6 VTi 95		<b>F8-6302</b>		
Belt Pulley, crankshaft	1.6	Number of Ribs: 5; Parameter: 6PK	<b>F8-6394</b>		H=25; d=44.05; Mounting points diam.[mm]=9; D=148; D1=142.9
Engine Mounting	1.6		<b>F8-6497</b>		
Engine Mounting	1.6		<b>F8-6500</b>		
Mounting, automatic transmission	1.6, 1.6 HDi 75, 1.6 HDi 90		<b>F8-6505</b>		
Rubber Buffer, suspension	1.6, 1.6 HDi 110, 1.6 HDi 115, 1.6 HDi 75, 1.6 HDi 90, 1.6 VTi 95		<b>F8-7585</b>		H=96
Belt Pulley, crankshaft	1.6 HDi 110, 1.6 HDi 75, 1.6 HDi 90	Number of Ribs: 5; Parameter: 6PK	<b>F8-7645</b>		D=157.75
Repair Kit, wheel suspension	1.6 HDi 75, 1.6 HDi 90		<b>G8-276-5017</b>		H=197; d=34; D=50,17
Repair Kit, wheel suspension	1.6 HDi 75, 1.6 HDi 90		<b>G8-276-5020</b>		H=197; d=34; D=50,2

**BX (XB-)****10/1982 → 06/1994**

Control Arm-/Trailing Arm Bush	1.8 D, 11, 14, 14 E, 15, 16, 16 E, 19, 19 D, 19 E, 19 E 4x4, 19 GTi, 19 GTi 16V, 19 GTi 4x4, TRD Turbo		<b>F8-5312</b>		
Bellow, driveshaft	11, 14, 14 E	ch.4206 →	<b>F8-5356</b>		D1=72; D219; L=172
Engine Mounting	1.6, 1.8 D, 1.9 All-wheel Drive, 1.9 GTi, 1.9 RD 4x4, 15, 16, 19 D, 19 GTi, 19 GTi 16V, TRD Turbo		<b>F8-5358</b>		
Engine Mounting	16 E	BDY	<b>F8-5358</b>		
Engine Mounting	1.8 D, 11, 14, 14 E, 15, 16, 16 E, 19, 19 D, 19 E, 19 GTi, 19 GTi 16V, TRD Turbo		<b>F8-5556</b>		
Engine Mounting	1.8 D, 19 D, TRD Turbo		<b>F8-5558</b>		
Engine Mounting	19 E 4x4, 19 GTi 4x4		<b>F8-5558</b>		
Belt Pulley, crankshaft	1.8 D, TRD Turbo	Number of Ribs: 6;	<b>F8-5643</b>		Belt Pulley Ø [mm]=156; W=44
Belt Pulley, crankshaft	1.9 RD 4x4, 19 D	Number of Ribs: 6	<b>F8-5643</b>		Belt Pulley Ø [mm]=156; W=44
Belt Pulley, crankshaft	19 D	D9A; Number of Ribs: 6	<b>F8-5643</b>		Belt Pulley Ø [mm]=156; W=44
Belt Pulley, crankshaft	1.8 D, 19 D, TRD Turbo		<b>F8-5646</b>		
Engine Mounting	11	H1A; Orga.04196 →	<b>F8-6487</b>		

<b>F5-1048</b>	<b>F5-1113</b>	<b>F5-1132</b>	<b>F8-3012</b>	<b>F8-5312</b>	<b>F8-5356</b>	<b>F8-5358</b>
Ref.Nr.: 77363468	Ref.Nr.: 12317576515	Ref.Nr.:	Ref.Nr.: 503527	Ref.Nr.: 96070064	Ref.Nr.: 328769	Ref.Nr.: 184373
<b>F8-5556</b>	<b>F8-5558</b>	<b>F8-5643</b>	<b>F8-5646</b>	<b>F8-6058</b>	<b>F8-6276</b>	<b>F8-6302</b>
Ref.Nr.: 1843.95	Ref.Nr.: 1843.97	Ref.Nr.: 96089 38980	Ref.Nr.: 0515K9	Ref.Nr.: 5038.F7	Ref.Nr.: 9612314280	Ref.Nr.: 503885
<b>F8-6394</b>	<b>F8-6487</b>	<b>F8-6497</b>	<b>F8-6500</b>	<b>F8-6505</b>	<b>F8-7585</b>	<b>F8-7645</b>
Ref.Nr.: 0515.R8	Ref.Nr.: 184472	Ref.Nr.: 1844.75	Ref.Nr.: 1844.36	Ref.Nr.: 1844.51	Ref.Nr.: 5033.70	Ref.Nr.: 0515.T3

**Article Description**

**Article Nr.**
**Fitting Position**

<b>BX (XB-)</b>			<b>10/1982 → 06/1994</b>		
Engine Mounting	11, 14, 14 E	Orga.04196→	<b>F8-6487</b>	⊕	
Engine Mounting	14 E	150C; Orga.04196→	<b>F8-6487</b>	⊕	
<b>BX Break (XB-)</b>			<b>09/1983 → 12/1994</b>		
Control Arm-/Trailing Arm Bush	14, 15, 16, 18 D, 19, 19 4x4, 19 CAT, 19 D, TRD Turbo		<b>F8-5312</b>	⊕ ⊕ ⊕	
Bellow, driveshaft	14	ch.4206→	<b>F8-5356</b>	⊕ ⊕ ⊕	D1=72; D219; L=172
Engine Mounting	1.6, 1.9 DT TXD, 15, 16, 18 D, 19 D, TRD Turbo		<b>F8-5358</b>	⊕ ⊕	
Engine Mounting	14, 15, 16, 18 D, 19, 19 CAT, 19 D, TRD Turbo		<b>F8-5556</b>	⊕	
Engine Mounting	18 D, 19 D, TRD Turbo		<b>F8-5558</b>	⊕	
Engine Mounting	19 4x4		<b>F8-5558</b>	⊕	
Belt Pulley, crankshaft	18 D, TRD Turbo	Number of Ribs: 6;	<b>F8-5643</b>		Belt Pulley Ø [mm]=156; W=44
Belt Pulley, crankshaft	19 D	Number of Ribs: 6	<b>F8-5643</b>		Belt Pulley Ø [mm]=156; W=44
Belt Pulley, crankshaft	1.9 D, 1.9 DT TXD, 18 D, 19 D, TRD Turbo		<b>F8-5646</b>		
Engine Mounting	1.4, 14	Orga.04196→	<b>F8-6487</b>	⊕	
<b>C1 (PM, PN)</b>			<b>06/2005 →</b>		
Dust Cover Kit, shock absorber	All Models		<b>AK-735416</b>	⊕ ⊕ ⊕	
Dust Cover Kit, shock absorber	All Models		<b>AK-735417</b>	⊕ ⊕ ⊕	
Anti-Friction Bearing	All Models		<b>F8-6266</b>	⊕	
Control Arm-/Trailing Arm Bush	All Models		<b>F8-6587</b>	⊕ ↓	
Top Strut Mounting	All Models		<b>F8-7170</b>	⊕ ⊕ ⊕	
Top Strut Mounting	All Models		<b>F8-7171</b>	⊕ ⊕ ⊕	
<b>C2 (JM)</b>			<b>09/2003 →</b>		
Dust Cover Kit, shock absorber	1.1, 1.4, 1.4 16V, 1.4 HDi, 1.6, 1.6 HDi, 1.6 VTS		<b>AK-735129</b>	⊕ ⊕ ⊕	
Alternator Freewheel Clutch	1.4 HDi, 1.6 HDi		<b>F5-1046</b>		
Alternator Freewheel Clutch	1.4 HDi, 1.6 HDi		<b>F5-1048</b>		
Anti-Friction Bearing	All Models		<b>F8-3012</b>	⊕ ⊕ ⊕	H=20; d=66; D=100
Control Arm-/Trailing Arm Bush	All Models		<b>F8-5629</b>	⊕ ⊕ ⊕ ↓	
Belt Pulley, crankshaft	1.1, 1.4, 1.6, 1.6 VTS	Number of Ribs: 5; Parameter: 6PK	<b>F8-6394</b>		H=25; d=44.05; Mounting points diam.[mm]=9; D=148; D1=142.9
Mounting, automatic transmission	1.6		<b>F8-6505</b>	⊕	
Top Strut Mounting	1.1, 1.4, 1.4 HDi, 1.6		<b>F8-6515</b>	⊕ ⊕ ⊕	
Top Strut Mounting	1.1, 1.4, 1.4 HDi, 1.6	08/2004 →;	<b>F8-6516</b>	⊕ ⊕ ⊕	
Top Strut Mounting	1.4 16V, 1.6 VTS		<b>F8-6516</b>	⊕ ⊕ ⊕	

<b>AK-735129</b>	<b>AK-735416</b>	<b>AK-735417</b>	<b>F5-1046</b>	<b>F5-1048</b>	<b>F8-3012</b>	<b>F8-5312</b>
Ref.Nr.: 525435	Ref.Nr.: 503198	Ref.Nr.: 521034	Ref.Nr.: 30667687	Ref.Nr.: 77363468	Ref.Nr.: 503527	Ref.Nr.: 96070064
<b>F8-5356</b>	<b>F8-5358</b>	<b>F8-5556</b>	<b>F8-5558</b>	<b>F8-5629</b>	<b>F8-5643</b>	<b>F8-5646</b>
Ref.Nr.: 328769	Ref.Nr.: 184373	Ref.Nr.: 1843.95	Ref.Nr.: 1843.97	Ref.Nr.: 9636181080	Ref.Nr.: 96089 38980	Ref.Nr.: 0515K9
<b>F8-6266</b>	<b>F8-6394</b>	<b>F8-6487</b>	<b>F8-6505</b>	<b>F8-6515</b>	<b>F8-6516</b>	<b>F8-6535</b>
Ref.Nr.: 5035C2	Ref.Nr.: 0515.R8	Ref.Nr.: 184472	Ref.Nr.: 1844.51	Ref.Nr.: 503849	Ref.Nr.: 5038F5	Ref.Nr.: 3523.AA

**Article Description**

**Article Nr.**
**Fitting Position**

<b>C2 (JM_)</b>			<b>09/2003 →</b>		
Control Arm-/Trailing Arm Bush	1.1, 1.4, 1.4 16V, 1.4 HDi, 1.6, 1.6 HDi, 1.6 VTS		<b>F8-6535</b>		d=18; D=55.2, 73; Thick. [mm]=48
Control Arm-/Trailing Arm Bush	1.1, 1.4, 1.4 HDi, 1.6		<b>F8-6537</b>		d=18; D=55.2, 73; Thick. [mm]=48
Spring Cap	All Models		<b>F8-6562</b>		
Spring Mounting	All Models		<b>F8-6563</b>		
Stabiliser Mounting	1.1, 1.4, 1.4 16V, 1.4 HDi, 1.6, 1.6 HDi, 1.6 VTS		<b>F8-6588</b>		D=18
Rubber Buffer, suspension	All Models		<b>F8-7586</b>		H=78
Belt Pulley, crankshaft	1.4 16V	Number of Ribs: 5; Parameter: 6PK	<b>F8-7644</b>		D=152
Belt Pulley, crankshaft	1.6, 1.6 VTS	Alternator Charge Current [A]: 120; Number of Ribs: 5; Parameter: 6PK	<b>F8-7644</b>		D=152
Belt Pulley, crankshaft	1.4 HDi	Number of Ribs: 5; Orga.10416→; Parameter: 6PK	<b>F8-7645</b>		D=157.75
Belt Pulley, crankshaft	1.6 HDi	Number of Ribs: 5; Parameter: 6PK	<b>F8-7645</b>		D=157.75
Rubber Buffer, suspension	1.1, 1.4, 1.4 16V, 1.4 HDi, 1.6, 1.6 VTS	<b>ST</b>	<b>F8-7711</b>		H=93
Engine Mounting	All Models		<b>F8-8141</b>		
<b>C2 ENTERPRISE</b>			<b>04/2009 →</b>		
Alternator Freewheel Clutch	All Models		<b>F5-1046</b>		
Anti-Friction Bearing	All Models		<b>F8-3012</b>		H=20; d=66; D=100
Spring Cap	All Models		<b>F8-6562</b>		
<b>C3 I (FC_)</b>			<b>02/2002 →</b>		
Dust Cover Kit, shock absorber	1.1 i, 1.4 16V, 1.4 16V HDi, 1.4 HDi, 1.4 i Bivalent, 1.6 16V, 1.6 16V HDi		<b>AK-735129</b>		
Alternator Freewheel Clutch	1.4 16V HDi, 1.4 HDi, 1.6 16V HDi		<b>F5-1046</b>		
Alternator Freewheel Clutch	1.4 16V HDi, 1.4 HDi, 1.6 16V HDi		<b>F5-1048</b>		
Anti-Friction Bearing	1.1 i, 1.4 16V, 1.4 16V HDi, 1.4 HDi, 1.4 i, 1.4 i Bivalent, 1.6 16V, 1.6 16V HDi, 1.6 Bioflex		<b>F8-3012</b>		H=20; d=66; D=100
Control Arm-/Trailing Arm Bush	1.1 i, 1.4 16V, 1.4 16V HDi, 1.4 HDi, 1.4 i, 1.4 i Bivalent, 1.6 16V, 1.6 16V HDi		<b>F8-5629</b>		
Belt Pulley, crankshaft	1.1 i, 1.4 16V, 1.4 i, 1.4 i Bivalent, 1.6 16V	Number of Ribs: 5; Parameter: 6PK	<b>F8-6394</b>		H=25; d=44.05; Mounting points diam.[mm]=9; D=148; D1=142.9
Top Strut Mounting	1.1 i, 1.4 16V, 1.4 16V HDi, 1.4 HDi, 1.4 i, 1.4 i Bivalent, 1.6 16V		<b>F8-6515</b>		
Top Strut Mounting	1.1 i, 1.4 16V, 1.4 16V HDi, 1.4 HDi, 1.4 i, 1.4 i Bivalent, 1.6 16V	08/2004 →;	<b>F8-6516</b>		
Top Strut Mounting	1.4 HDi, 1.6 16V HDi		<b>F8-6516</b>		
Control Arm-/Trailing Arm Bush	1.1 i, 1.4 16V, 1.4 16V HDi, 1.4 HDi, 1.4 i, 1.4 i Bivalent, 1.6 16V, 1.6 16V HDi		<b>F8-6535</b>		d=18; D=55.2, 73; Thick. [mm]=48
Control Arm-/Trailing Arm Bush	1.1 i, 1.4 i Bivalent		<b>F8-6537</b>		d=18; D=55.2, 73; Thick. [mm]=48

<b>AK-735129</b>	<b>F5-1046</b>	<b>F5-1048</b>	<b>F8-3012</b>	<b>F8-5629</b>	<b>F8-6394</b>	<b>F8-6515</b>
Ref.Nr.: 525435	Ref.Nr.: 30667687	Ref.Nr.: 77363468	Ref.Nr.: 503527	Ref.Nr.: 9636181080	Ref.Nr.: 0515.R8	Ref.Nr.: 503849
<b>F8-6516</b>	<b>F8-6535</b>	<b>F8-6537</b>	<b>F8-6562</b>	<b>F8-6563</b>	<b>F8-6588</b>	<b>F8-7586</b>
Ref.Nr.: 5038F5	Ref.Nr.: 3523.AA	Ref.Nr.: 3523.99	Ref.Nr.: 5033.75	Ref.Nr.: 503174	Ref.Nr.: 509497	Ref.Nr.: 5166.67
<b>F8-7644</b>	<b>F8-7645</b>	<b>F8-7711</b>	<b>F8-8141</b>			
Ref.Nr.: 0515.R4	Ref.Nr.: 0515.T3	Ref.Nr.: 503382	Ref.Nr.: 180659			

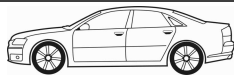
**Article Description**

**Article Nr.**
**Fitting Position**

<b>C3 I (FC_)</b>			<b>02/2002 →</b>		
Spring Cap	1.1 i, 1.4 16V, 1.4 16V HDi, 1.4 Bioflex, 1.4 HDi, 1.4 i, 1.4 i Bivalent, 1.6 16V, 1.6 16V HDi, 1.6 Bioflex		<b>F8-6562</b>		
Spring Mounting	1.1 i, 1.4 16V, 1.4 16V HDi, 1.4 Bioflex, 1.4 HDi, 1.4 i, 1.4 i Bivalent, 1.6 16V, 1.6 16V HDi, 1.6 Bioflex		<b>F8-6563</b>		
Stabiliser Mounting	1.1 i, 1.4 16V, 1.4 16V HDi, 1.4 HDi, 1.4 i, 1.4 i Bivalent, 1.6 16V, 1.6 16V HDi		<b>F8-6589</b>		D=19
Stabiliser Mounting	1.1 i, 1.4 16V, 1.4 16V HDi, 1.4 HDi, 1.4 i, 1.4 i Bivalent, 1.6 16V		<b>F8-6590</b>		D=20
Belt Pulley, crankshaft	1.4 16V HDi, 1.6 16V HDi	Number of Ribs: 6	<b>F8-7082</b>		Belt Pulley Ø [mm]=152; Mounting points diam.[mm]=30; W=34
Belt Pulley, crankshaft	1.6 16V HDi	Number of Ribs: 6; Orga.→10555	<b>F8-7082</b>		Belt Pulley Ø [mm]=152; Mounting points diam.[mm]=30; W=34
Rubber Buffer, suspension	1.4 HDi, 1.4 i, 1.4 i Bivalent, 1.6 16V	Orga. 10577→; <b>HD</b>	<b>F8-7585</b>		H=96
Rubber Buffer, suspension	1.6 Bioflex		<b>F8-7585</b>		H=96
Rubber Buffer, suspension	1.1 i, 1.4 16V, 1.4 16V HDi, 1.4 HDi, 1.4 i, 1.6 16V, 1.6 16V HDi		<b>F8-7586</b>		H=78
Rubber Buffer, suspension	1.1 i, 1.4 16V, 1.4 16V HDi, 1.4 HDi, 1.4 i, 1.4 i Bivalent, 1.6 16V, 1.6 16V HDi	<b>ST</b>	<b>F8-7587</b>		H=94
Belt Pulley, crankshaft	1.4 16V	Number of Ribs: 5; Parameter: 6PK; for vehicles with start-stop function	<b>F8-7644</b>		D=152
Belt Pulley, crankshaft	1.6 16V	Number of Ribs: 5; Orga.11614→; Parameter: 6PK; <b>MS</b>	<b>F8-7644</b>		D=152
Belt Pulley, crankshaft	1.4 HDi	Number of Ribs: 5; Orga.10416→; Parameter: 6PK	<b>F8-7645</b>		D=157.75
Belt Pulley, crankshaft	1.6 16V HDi	Number of Ribs: 5; Orga.10556→; Parameter: 6PK	<b>F8-7645</b>		D=157.75
Engine Mounting	1.1 i, 1.4 16V, 1.4 16V HDi, 1.4 HDi, 1.4 i, 1.4 i Bivalent, 1.6 16V, 1.6 16V HDi		<b>F8-8141</b>		
<b>C3 Pluriel (HB_)</b>			<b>05/2003 →</b>		
Dust Cover Kit, shock absorber	1.4, 1.4 HDi, 1.6		<b>AK-735129</b>		
Alternator Freewheel Clutch	1.4 HDi		<b>F5-1046</b>		
Alternator Freewheel Clutch	1.4 HDi		<b>F5-1048</b>		
Anti-Friction Bearing	All Models		<b>F8-3012</b>		H=20; d=66; D=100
Control Arm-/Trailing Arm Bush	1.4, 1.4 HDi, 1.6		<b>F8-5629</b>		
Belt Pulley, crankshaft	1.4	Number of Ribs: 5; Parameter: 6PK; <b>MS</b>	<b>F8-6394</b>		H=25; d=44.05; Mounting points diam.[mm]=9; D=148; D1=142.9
Belt Pulley, crankshaft	1.4 Hybrid, 1.6	Number of Ribs: 5; Parameter: 6PK	<b>F8-6394</b>		H=25; d=44.05; Mounting points diam.[mm]=9; D=148; D1=142.9
Top Strut Mounting	1.4, 1.4 HDi, 1.6		<b>F8-6515</b>		
Top Strut Mounting	1.4 Hybrid		<b>F8-6516</b>		

<b>AK-735129</b>	<b>F5-1046</b>	<b>F5-1048</b>	<b>F8-3012</b>	<b>F8-5629</b>	<b>F8-6394</b>	<b>F8-6515</b>
Ref.Nr.: 525435	Ref.Nr.: 30667687	Ref.Nr.: 77363468	Ref.Nr.: 503527	Ref.Nr.: 9636181080	Ref.Nr.: 0515.R8	Ref.Nr.: 503849
<b>F8-6516</b>	<b>F8-6562</b>	<b>F8-6563</b>	<b>F8-6589</b>	<b>F8-6590</b>	<b>F8-7082</b>	<b>F8-7585</b>
Ref.Nr.: 5038F5	Ref.Nr.: 5033.75	Ref.Nr.: 503174	Ref.Nr.: 5094.A6	Ref.Nr.: 509496	Ref.Nr.: 0515.R0	Ref.Nr.: 5033.70
<b>F8-7586</b>	<b>F8-7587</b>	<b>F8-7644</b>	<b>F8-7645</b>	<b>F8-8141</b>		
Ref.Nr.: 5166.67	Ref.Nr.: 5033.72	Ref.Nr.: 0515.R4	Ref.Nr.: 0515.T3	Ref.Nr.: 180659		

**Article Description****Article Nr.****Fitting Position**

<b>C3 Pluriel (HB_)</b>			<b>05/2003 →</b>		
Top Strut Mounting	1.4, 1.4 HDi, 1.6	08/2004 →;	<b>F8-6516</b>		
Control Arm-/Trailing Arm Bush	All Models		<b>F8-6535</b>		d=18; D=55.2, 73; Thick. [mm]=48
Spring Cap	All Models		<b>F8-6562</b>		
Spring Mounting	All Models		<b>F8-6563</b>		
Stabiliser Mounting	All Models		<b>F8-6589</b>		D=19
Stabiliser Mounting	All Models		<b>F8-6590</b>		D=20
Rubber Buffer, suspension	All Models	Orga.10577 →; <b>HD</b>	<b>F8-7585</b>		H=96
Rubber Buffer, suspension	1.4, 1.4 HDi, 1.6		<b>F8-7586</b>		H=78
Rubber Buffer, suspension	All Models	<b>ST</b>	<b>F8-7587</b>		H=94
Belt Pulley, crankshaft	1.4 HDi	Number of Ribs: 5; Orga.10556 →; Parameter: 6PK	<b>F8-7645</b>		D=157.75
Engine Mounting	1.4, 1.4 HDi, 1.6		<b>F8-8141</b>		
<b>C3 II</b>			<b>11/2009 →</b>		
Alternator Freewheel Clutch	1.6 HDi 90		<b>F5-1046</b>		
Alternator Freewheel Clutch	1.4 VTI 95, 1.6 VTI 120		<b>F5-1113</b>		
Alternator Freewheel Clutch	1.4 VTI 95, 1.6 VTI 120		<b>F5-1132</b>		
Anti-Friction Bearing	1.0 VTI 68, 1.1, 1.1 BiFuel, 1.2 VTI 82, 1.4, 1.4 HDi 70, 1.4 VTI 95, 1.6 HDi, 1.6 HDi 110, 1.6 HDi 90, 1.6 VTI 120		<b>F8-3012</b>		H=20; d=66; D=100
Belt Pulley, crankshaft	1.1, 1.1 BiFuel, 1.4	Number of Ribs: 5; Parameter: 6PK	<b>F8-6394</b>		H=25; d=44.05; Mounting points diam.[mm]=9; D=148; D1=142.9
Spring Cap	1.0 VTI 68, 1.1 BiFuel, 1.2 VTI 82, 1.4, 1.4 HDi 70, 1.4 VTI 95, 1.6 HDi, 1.6 HDi 110, 1.6 HDi 115, 1.6 HDi 90, 1.6 VTI 120		<b>F8-6562</b>		
Belt Pulley, crankshaft	1.4 HDi 70, 1.6 HDi, 1.6 HDi 110, 1.6 HDi 90	Number of Ribs: 5; Parameter: 6PK	<b>F8-7645</b>		D=157.75
Rubber Buffer, suspension	1.1, 1.1 BiFuel, 1.4, 1.4 HDi 70, 1.4 VTI 95, 1.6 HDi, 1.6 HDi 110, 1.6 HDi 90, 1.6 VTI 120	<b>ST</b>	<b>F8-7659</b>		H=85
Protective Cap/Bellow, shock absorber	1.0 VTI 68, 1.1, 1.1 BiFuel, 1.2 VTI 82, 1.4, 1.4 HDi 70, 1.4 VTI 95, 1.6 HDi, 1.6 HDi 110, 1.6 HDi 90, 1.6 VTI 120	<b>ST</b>	<b>F8-7660</b>		H=190
Engine Mounting	1.1, 1.1 BiFuel, 1.4, 1.4 HDi 70, 1.4 LPG, 1.4 VTI 95, 1.6 VTI 120		<b>F8-8141</b>		
<b>C3 Picasso</b>			<b>02/2009 →</b>		
Alternator Freewheel Clutch	1.6 HDi		<b>F5-1046</b>		
Alternator Freewheel Clutch	1.6 HDi		<b>F5-1048</b>		
Alternator Freewheel Clutch	1.4 VTI 95, 1.4 VTI 95 LPG, 1.6 VTI 120		<b>F5-1113</b>		
Alternator Freewheel Clutch	1.4 VTI 95, 1.4 VTI 95 LPG, 1.6 VTI 120		<b>F5-1132</b>		
Anti-Friction Bearing	1.4 VTI 95, 1.6 HDi, 1.6 HDi 110, 1.6 HDi 115, 1.6 HDi 90		<b>F8-3012</b>		H=20; d=66; D=100

<b>F5-1046</b>	<b>F5-1048</b>	<b>F5-1113</b>	<b>F5-1132</b>	<b>F8-3012</b>	<b>F8-6394</b>	<b>F8-6516</b>
Ref.Nr.: 30667687	Ref.Nr.: 77363468	Ref.Nr.: 12317576515	Ref.Nr.:	Ref.Nr.: 503527	Ref.Nr.: 0515.R8	Ref.Nr.: 5038F5
<b>F8-6535</b>	<b>F8-6562</b>	<b>F8-6563</b>	<b>F8-6589</b>	<b>F8-6590</b>	<b>F8-7585</b>	<b>F8-7586</b>
Ref.Nr.: 3523.AA	Ref.Nr.: 5033.75	Ref.Nr.: 503174	Ref.Nr.: 5094.A6	Ref.Nr.: 509496	Ref.Nr.: 5033.70	Ref.Nr.: 5166.67
<b>F8-7587</b>	<b>F8-7645</b>	<b>F8-7659</b>	<b>F8-7660</b>	<b>F8-8141</b>		
Ref.Nr.: 5033.72	Ref.Nr.: 0515.T3	Ref.Nr.: 5033E7	Ref.Nr.: 525448	Ref.Nr.: 180659		

Article Description



Article Nr.

Fitting Position



<b>C3 Picasso</b>			<b>02/2009 →</b>		
Anti-Friction Bearing	1.6 VTi 120	EP6	<b>F8-3012</b>	⊕ ⊕	H=20; d=66; D=100
Control Arm-/Trailing Arm Bush	1.4 VTi 95, 1.6 HDi, 1.6 VTi 120		<b>F8-5629</b>	⊕ ⊕ ⊕ ↓	
Control Arm-/Trailing Arm Bush	1.4 VTi 95, 1.6 HDi, 1.6 VTi 120		<b>F8-6535</b>		d=18; D=55.2, 73; Thick. [mm]=48
Spring Cap	1.4 VTi 95, 1.6 HDi, 1.6 HDi 110, 1.6 HDi 115, 1.6 HDi 90, 1.6 VTi 120		<b>F8-6562</b>		
Belt Pulley, crankshaft	1.6 HDi, 1.6 HDi 110, 1.6 HDi 90	Number of Ribs: 5; Parameter: 6PK	<b>F8-7645</b>		D=157.75
Protective Cap/Bellow, shock absorber	1.4 VTi 95, 1.4 VTi 95 LPG, 1.6 HDi, 1.6 HDi 110, 1.6 HDi 115, 1.6 HDi 90, 1.6 VTi 120	ST	<b>F8-7660</b>	⊕ ⊕	H=190
<b>C4I (LC_)</b>			<b>11/2004 → 07/2011</b>		
Dust Cover Kit, shock absorber	1.4 16V, 1.6 16V, 1.6 HDi, 2.0 16V, 2.0 HDi		<b>AK-735068</b>		
Dust Cover Kit, shock absorber	1.4 16V, 1.6 16V, 1.6 16V Bio-Flex, 1.6 HDi, 1.6 THP 140, 1.6 THP 150, 1.6 VTi 120, 2.0 16V, 2.0 HDi		<b>AK-735438</b>	⊕ ⊕	
Alternator Freewheel Clutch	1.6 HDi, 2.0 16V, 2.0 HDi		<b>F5-1046</b>		
Alternator Freewheel Clutch	1.6 HDi		<b>F5-1048</b>		
Alternator Freewheel Clutch	1.6 THP 140, 1.6 THP 150, 1.6 VTi 120		<b>F5-1113</b>		
Alternator Freewheel Clutch	1.6 THP 140, 1.6 THP 150, 1.6 VTi 120		<b>F5-1132</b>		
Anti-Friction Bearing	1.4 16V, 1.6 16V, 1.6 16V Bio-Flex, 1.6 HDi, 1.6 THP 140, 1.6 THP 150, 1.6 VTi 120, 2.0 16V, 2.0 HDi		<b>F8-3012</b>	⊕ ⊕	H=20; d=66; D=100
Top Strut Mounting	1.4 16V, 1.6 16V, 1.6 16V Bio-Flex, 1.6 HDi, 2.0 16V, 2.0 HDi		<b>F8-6058</b>	⊕ ⊕	
Control Arm-/Trailing Arm Bush	1.4 16V, 1.6 16V, 1.6 16V Bio-Flex, 1.6 HDi, 1.6 THP 140, 1.6 THP 150, 1.6 VTi 120, 2.0 16V, 2.0 HDi		<b>F8-6134</b>		L=56.2; D=55.5
Top Strut Mounting	1.4 16V, 1.6 16V, 1.6 16V Bio-Flex, 1.6 HDi, 2.0 16V, 2.0 HDi		<b>F8-6302</b>		
Belt Pulley, crankshaft	1.4 16V, 1.6 16V, 1.6 16V Bio-Flex	Number of Ribs: 5; Parameter: 6PK	<b>F8-6394</b>		H=25; d=44.05; Mounting points diam.[mm]=9; D=148; D1=142.9
Engine Mounting	1.6 HDi	Automated	<b>F8-6500</b>	⊕	
Engine Mounting	1.6 THP 140, 1.6 THP 150, 2.0 16V		<b>F8-6500</b>	⊕	
Engine Mounting	2.0 HDi		<b>F8-6500</b>	⊕	
Mounting, automatic transmission	1.4 16V, 1.6 16V, 1.6 16V Bio-Flex, 1.6 HDi, 1.6 VTi 120		<b>F8-6505</b>	⊕	
Spring Cap	1.4 16V, 1.6 16V, 1.6 16V Bio-Flex, 1.6 HDi, 1.6 THP 140, 1.6 THP 150, 1.6 VTi 120, 2.0 16V, 2.0 HDi		<b>F8-6562</b>		
Rubber Buffer, suspension	1.4 16V, 1.6 16V, 1.6 16V Bio-Flex, 1.6 HDi, 1.6 THP 140, 1.6 THP 150, 1.6 VTi 120, 2.0 16V, 2.0 HDi		<b>F8-6564</b>	⊕ ⊕	
Mounting, axle beam	1.4 16V, 1.6 16V, 1.6 16V Bio-Flex, 1.6 HDi, 1.6 THP 140, 1.6 THP 150, 1.6 VTi 120, 2.0 16V, 2.0 HDi	for OE: 5131A4	<b>F8-6591</b>	⊕ ⊕	H=82; d=16.8; D=71.5
Mounting, axle beam	1.6 16V, 1.6 16V Bio-Flex, 2.0 16V	for OE: 5131A5	<b>F8-6592</b>	⊕ ⊕	
Stabiliser Mounting	1.4 16V, 1.6 16V, 1.6 16V Bio-Flex, 1.6 HDi, 1.6 THP 140, 1.6 THP 150, 1.6 VTi 120, 2.0 16V, 2.0 HDi		<b>F8-6594</b>	⊕ ⊕	d=22





**Article Description****Article Nr.****Fitting Position**

<b>C4 I (LC_)</b>			<b>11/2004 → 07/2011</b>		
Belt Pulley, crankshaft	1.6 HDi	Number of Ribs: 6	<b>F8-7082</b>		Belt Pulley Ø [mm]=152; Mounting points diam.[mm]=30; W=34
Top Strut Mounting	1.4 16V, 1.6 16V, 1.6 16V Bio-Flex, 1.6 HDi, 1.6 THP 140, 1.6 THP 150, 1.6 VTI 120, 2.0 16V, 2.0 HDi	Aluminium;	<b>F8-7169</b>		H=52; d=10.2; D=62
Rubber Buffer, suspension	1.4 16V, 1.6 16V, 1.6 16V Bio-Flex, 1.6 HDi, 1.6 THP 140, 1.6 THP 150, 1.6 VTI 120, 2.0 16V, 2.0 HDi	Orga.10647→; Orga.→11045	<b>F8-7585</b>		H=96
Belt Pulley, crankshaft	1.4 16V, 1.6 16V Bio-Flex	Alternator Charge Current [A]: 120; Number of Ribs: 5; Parameter: 6PK	<b>F8-7644</b>		D=152
Belt Pulley, crankshaft	1.6 HDi	Number of Ribs: 5; Orga.10556→; Parameter: 6PK	<b>F8-7645</b>		D=157.75
Belt Pulley, crankshaft	1.6 HDi	Number of Ribs: 5; Parameter: 6PK	<b>F8-7645</b>		D=157.75
Belt Pulley, crankshaft	2.0 HDi		<b>F8-7861</b>		
Engine Mounting	1.6 HDi, 2.0 16V		<b>F8-8184</b>		
Bellow, steering	1.4 16V, 1.6 16V, 1.6 16V Bio-Flex, 1.6 HDi, 2.0 16V, 2.0 HDi	; with clamps;	<b>LM-10040S</b>		d1=17; d2=60; L [mm]=183
<b>C4 II (B7)</b>			<b>11/2009 →</b>		
Alternator Freewheel Clutch	1.6 HDi 110, 1.6 HDi 90		<b>F5-1046</b>		
Alternator Freewheel Clutch	1.4 VTI 95, 1.6 THP 155, 1.6 VTI 120		<b>F5-1113</b>		
Alternator Freewheel Clutch	1.4 VTI 95, 1.6 THP 155, 1.6 VTI 120		<b>F5-1132</b>		
Anti-Friction Bearing	1.4 VTI 95, 1.6 HDi 110, 1.6 HDi 115, 1.6 HDi 90, 1.6 THP 155, 1.6 VTI 120, 1.6 VTI 120 LPG, 2.0 HDi 150		<b>F8-3012</b>		H=20; d=66; D=100
Belt Pulley, crankshaft	1.6 HDi 110, 1.6 HDi 90	Number of Ribs: 5; Parameter: 6PK	<b>F8-7645</b>		D=157.75
<b>C4 Saloon</b>			<b>07/2006 → 07/2011</b>		
Alternator Freewheel Clutch	1.6 HDi, 2.0 16V		<b>F5-1046</b>		
Anti-Friction Bearing	All Models		<b>F8-3012</b>		H=20; d=66; D=100
Top Strut Mounting	All Models		<b>F8-6058</b>		
Top Strut Mounting	All Models		<b>F8-6302</b>		
Belt Pulley, crankshaft	1.6 16V	Number of Ribs: 5; Parameter: 6PK	<b>F8-6394</b>		H=25; d=44.05; Mounting points diam.[mm]=9; D=148; D1=142.9
Engine Mounting	2.0 16V		<b>F8-6500</b>		
Spring Cap	All Models		<b>F8-6562</b>		
Rubber Buffer, suspension	All Models		<b>F8-6564</b>		
Top Strut Mounting	All Models	Aluminium;	<b>F8-7169</b>		H=52; d=10.2; D=62
Rubber Buffer, suspension	1.6 16V, 1.6 HDi	Orga.10647→; Orga.→11045	<b>F8-7585</b>		H=96
Belt Pulley, crankshaft	1.6 16V	Alternator Charge Current [A]: 120; Number of Ribs: 5; Parameter: 6PK	<b>F8-7644</b>		D=152
Belt Pulley, crankshaft	1.6 HDi	Number of Ribs: 5; Orga.10556→; Parameter: 6PK	<b>F8-7645</b>		D=157.75

<b>F5-1046</b>	<b>F5-1113</b>	<b>F5-1132</b>	<b>F8-3012</b>	<b>F8-6058</b>	<b>F8-6302</b>	<b>F8-6394</b>
Ref.Nr.: 30667687	Ref.Nr.: 12317576515	Ref.Nr.:	Ref.Nr.: 503527	Ref.Nr.: 5038.F7	Ref.Nr.: 503885	Ref.Nr.: 0515.R8
<b>F8-6500</b>	<b>F8-6562</b>	<b>F8-6564</b>	<b>F8-7082</b>	<b>F8-7169</b>	<b>F8-7585</b>	<b>F8-7644</b>
Ref.Nr.: 1844.36	Ref.Nr.: 5033.75	Ref.Nr.: 503371	Ref.Nr.: 0515.R0	Ref.Nr.: 9658296580	Ref.Nr.: 5033.70	Ref.Nr.: 0515.R4
<b>F8-7645</b>	<b>F8-7861</b>	<b>F8-8184</b>	<b>LM-10040S</b>			
Ref.Nr.: 0515.T3	Ref.Nr.: 0515.Q8	Ref.Nr.: 1806.33	Ref.Nr.: 4066.82			

Article Description



Article Nr.

Fitting Position



C4 Coupé (LA_)		11/2004 → 07/2011	
Dust Cover Kit, shock absorber	1.4 16V, 1.6 16V, 1.6 HDi, 2.0 16V, 2.0 HDi		AK-735068
Dust Cover Kit, shock absorber	1.4 16V, 1.6 16V, 1.6 HDi, 1.6 THP 150, 1.6 VTi 120, 2.0 16V, 2.0 HDi		AK-735438
Alternator Freewheel Clutch	1.6 HDi, 2.0 HDi		F5-1046
Alternator Freewheel Clutch	1.6 HDi		F5-1048
Alternator Freewheel Clutch	1.6 THP 150, 1.6 VTi 120		F5-1113
Alternator Freewheel Clutch	1.6 THP 150, 1.6 VTi 120		F5-1132
Anti-Friction Bearing	1.4 16V, 1.6 16V, 1.6 HDi, 1.6 THP 150, 1.6 VTi 120, 2.0 16V, 2.0 HDi		F8-3012    H=20; d=66; D=100
Top Strut Mounting	1.4 16V, 1.6 16V, 1.6 HDi, 2.0 16V, 2.0 HDi		F8-6058
Control Arm-/Trailing Arm Bush	1.4 16V, 1.6 16V, 1.6 HDi, 1.6 THP 150, 1.6 VTi 120, 2.0 16V, 2.0 HDi		F8-6134  L=56.2; D=55.5
Top Strut Mounting	1.4 16V, 1.6 16V, 1.6 HDi, 2.0 16V, 2.0 HDi		F8-6302
Belt Pulley, crankshaft	1.4 16V, 1.6 16V	Number of Ribs: 5; Parameter: 6PK	F8-6394 H=25; d=44.05; Mounting points diam.[mm]=9; D=148; D1=142.9
Engine Mounting	1.6 HDi	Automated	F8-6500
Engine Mounting	1.6 THP 150, 2.0 16V		F8-6500
Engine Mounting	2.0 HDi		F8-6500
Mounting, automatic transmission	1.4 16V, 1.6 16V, 1.6 HDi, 1.6 VTi 120		F8-6505
Spring Cap	1.4 16V, 1.6 16V, 1.6 HDi, 1.6 THP 150, 1.6 VTi 120, 2.0 16V, 2.0 HDi		F8-6562
Rubber Buffer, suspension	1.4 16V, 1.6 16V, 1.6 HDi, 1.6 THP 150, 1.6 VTi 120, 2.0 16V, 2.0 HDi		F8-6564
Mounting, axle beam	1.4 16V, 1.6 16V, 1.6 HDi, 1.6 THP 150, 1.6 VTi 120, 2.0 16V, 2.0 HDi	for OE: 5131A4	F8-6591    H=82; d=16.8; D=71.5
Mounting, axle beam	1.6 16V	for OE: 5131A5	F8-6592
Stabiliser Mounting	1.4 16V, 1.6 16V, 1.6 HDi, 1.6 THP 150, 1.6 VTi 120, 2.0 16V, 2.0 HDi		F8-6594    d=22
Belt Pulley, crankshaft	1.6 HDi	Number of Ribs: 6	F8-7082 Belt Pulley Ø [mm]=152; Mounting points diam.[mm]=30; W=34
Top Strut Mounting	1.4 16V, 1.6 16V, 1.6 HDi, 1.6 THP 150, 1.6 VTi 120, 2.0 16V, 2.0 HDi	Aluminium;	F8-7169    H=52; d=10.2; D=62
Rubber Buffer, suspension	1.4 16V, 1.6 16V, 1.6 HDi, 1.6 THP 150, 1.6 VTi 120, 2.0 16V, 2.0 HDi	Orga.10647→; Orga.→11045	F8-7585    H=96
Rubber Buffer, suspension	2.0 HDi		F8-7585    H=96
Belt Pulley, crankshaft	1.4 16V, 1.6 16V	Alternator Charge Current [A]: 120; Number of Ribs: 5; Parameter: 6PK	F8-7644 D=152
Belt Pulley, crankshaft	1.6 HDi	Number of Ribs: 5; Orga.10556→; Parameter: 6PK	F8-7645 D=157.75
Belt Pulley, crankshaft	1.6 HDi	Number of Ribs: 5; Parameter: 6PK	F8-7645 D=157.75

<b>AK-735068</b>	<b>AK-735438</b>	<b>F5-1046</b>	<b>F5-1048</b>	<b>F5-1113</b>	<b>F5-1132</b>	<b>F8-3012</b>
Ref.Nr.: 503370	Ref.Nr.: 525442	Ref.Nr.: 30667687	Ref.Nr.: 77363468	Ref.Nr.: 12317576515	Ref.Nr.:	Ref.Nr.: 503527
<b>F8-6058</b>	<b>F8-6134</b>	<b>F8-6302</b>	<b>F8-6394</b>	<b>F8-6500</b>	<b>F8-6505</b>	<b>F8-6562</b>
Ref.Nr.: 5038.F7	Ref.Nr.: 3523.91	Ref.Nr.: 503885	Ref.Nr.: 0515.R8	Ref.Nr.: 1844.36	Ref.Nr.: 1844.51	Ref.Nr.: 5033.75
<b>F8-6564</b>	<b>F8-6591</b>	<b>F8-6592</b>	<b>F8-6594</b>	<b>F8-7082</b>	<b>F8-7169</b>	<b>F8-7585</b>
Ref.Nr.: 503371	Ref.Nr.: 5131.A4	Ref.Nr.: 5131.A5	Ref.Nr.: 509488	Ref.Nr.: 0515.R0	Ref.Nr.: 9658296580	Ref.Nr.: 5033.70

**Article Description****Article Nr.****Fitting Position**

<b>C4 Coupe (LA_)</b>				<b>11/2004 → 07/2011</b>	
Engine Mounting	1.6 HDi, 2.0 16V		<b>F8-8184</b>		
Bellow, steering	1.4 16V, 1.6 16V, 1.6 HDi, 1.6 THP 150, 1.6 VTi 120, 2.0 16V, 2.0 HDi	; ; with clamps;	<b>LM-10040S</b>		d1=17; d2=60; L [mm]=183
<b>C4 Picasso I (UD_)</b>				<b>02/2007 → 08/2013</b>	
Alternator Freewheel Clutch	1.6 HDi, 2.0 HDi 138		<b>F5-1046</b>		
Alternator Freewheel Clutch	1.6 HDi, 2.0 HDi 138, 2.0 HDi 150		<b>F5-1048</b>		
Alternator Freewheel Clutch	1.6 16V, 1.6 THP 140, 1.6 THP 155, 1.6 VTi 120		<b>F5-1113</b>		
Alternator Freewheel Clutch	1.6 16V, 1.6 THP 140, 1.6 THP 155, 1.6 VTi 120		<b>F5-1132</b>		
Anti-Friction Bearing	1.6 16V, 1.6 HDi, 1.6 HDi 110, 1.6 THP 140, 1.6 THP 155, 1.6 VTi 120, 1.8 i 16V, 2.0 HDi 138, 2.0 HDi 150, 2.0 HDi 165, 2.0 i 16V		<b>F8-3012</b>		H=20; d=66; D=100
Top Strut Mounting	1.6 16V, 1.6 HDi, 1.6 HDi 110, 1.6 THP 140, 1.6 THP 155, 1.6 VTi 120, 1.8 i 16V, 2.0 HDi 138, 2.0 HDi 150, 2.0 HDi 165, 2.0 i 16V		<b>F8-6058</b>		
Control Arm-/Trailing Arm Bush	1.6 HDi, 1.6 THP 140, 1.6 VTi 120, 1.8 i 16V, 2.0 HDi 138, 2.0 i 16V		<b>F8-6134</b>		L=56.2; D=55.5
Top Strut Mounting	1.6 16V, 1.6 HDi, 1.6 HDi 110, 1.6 THP 140, 1.6 THP 155, 1.6 VTi 120, 1.8 i 16V, 2.0 HDi 138, 2.0 HDi 150, 2.0 HDi 165, 2.0 i 16V		<b>F8-6302</b>		
Engine Mounting	1.6 16V, 1.6 THP 140, 1.8 i 16V, 2.0 i 16V		<b>F8-6500</b>		
Engine Mounting	1.6 HDi	DV6TED4; Automated ; for vehicles with diesel soot filter	<b>F8-6500</b>		
Engine Mounting	2.0 HDi 138	Automated	<b>F8-6500</b>		
Engine Mounting	2.0 HDi 150	DW10CTED4	<b>F8-6500</b>		
Mounting, automatic transmission	1.6 HDi, 1.6 VTi 120		<b>F8-6505</b>		
Spring Cap	1.6 16V, 1.6 HDi, 1.6 HDi 110, 1.6 THP 140, 1.6 THP 155, 1.6 VTi 120, 1.8 i 16V, 2.0 HDi 138, 2.0 HDi 150, 2.0 HDi 165, 2.0 i 16V		<b>F8-6562</b>		
Stabiliser Mounting	1.6 HDi, 1.6 THP 140, 1.6 VTi 120, 1.8 i 16V, 2.0 HDi 138, 2.0 i 16V		<b>F8-6594</b>		d=22
Belt Pulley, crankshaft	1.6 HDi	Number of Ribs: 6; Orga.→10555	<b>F8-7082</b>		Belt Pulley Ø [mm]=152; Mounting points diam.[mm]=30; W=34
Rubber Buffer, suspension	1.6 16V, 1.6 HDi, 1.6 HDi 110, 1.6 THP 140, 1.6 THP 155, 1.6 VTi 120, 1.8 i 16V, 2.0 HDi 138, 2.0 HDi 150, 2.0 HDi 165, 2.0 i 16V		<b>F8-7585</b>		H=96
Belt Pulley, crankshaft	1.6 HDi, 1.6 HDi 110	Number of Ribs: 5; Parameter: 6PK	<b>F8-7645</b>		D=157.75
Engine Mounting	1.6 HDi, 2.0 i 16V		<b>F8-8184</b>		
Bellow, steering	1.6 16V, 1.6 HDi, 1.6 THP 140, 1.6 VTi 120, 1.8 i 16V, 2.0 HDi 138, 2.0 HDi 150, 2.0 i 16V	with clamps	<b>LM-10040S</b>		d1=17; d2=60; L [mm]=183

<b>F5-1046</b>	<b>F5-1048</b>	<b>F5-1113</b>	<b>F5-1132</b>	<b>F8-3012</b>	<b>F8-6058</b>	<b>F8-6134</b>
Ref.Nr.: 30667687	Ref.Nr.: 77363468	Ref.Nr.: 12317576515	Ref.Nr.:	Ref.Nr.: 503527	Ref.Nr.: 5038.F7	Ref.Nr.: 3523.91
<b>F8-6302</b>	<b>F8-6500</b>	<b>F8-6505</b>	<b>F8-6562</b>	<b>F8-6594</b>	<b>F8-7082</b>	<b>F8-7585</b>
Ref.Nr.: 503885	Ref.Nr.: 1844.36	Ref.Nr.: 1844.51	Ref.Nr.: 5033.75	Ref.Nr.: 509488	Ref.Nr.: 0515.R0	Ref.Nr.: 5033.70
<b>F8-7645</b>	<b>F8-8184</b>	<b>LM-10040S</b>				
Ref.Nr.: 0515.T3	Ref.Nr.: 1806.33	Ref.Nr.: 4066.82				

Article Description



Article Nr.

Fitting Position



<b>C4 Picasso II</b>		<b>02/2013 →</b>	
Anti-Friction Bearing	1.6 HdI, 1.6 THP		<b>F8-3012</b> ⊕ ⊕
Top Strut Mounting	1.6 HdI, 1.6 THP		<b>F8-6058</b> ⊕ ⊕
Top Strut Mounting	1.6 HdI, 1.6 THP		<b>F8-6302</b>
Spring Cap	1.6 HdI, 1.6 THP, 1.6 VTi 120		<b>F8-6562</b>
<b>C4 Grand Picasso I (UA_)</b>		<b>10/2006 →</b>	
Alternator Freewheel Clutch	1.6 HDi, 2.0 HDi 138		<b>F5-1046</b>
Alternator Freewheel Clutch	1.6 16V, 1.6 THP 155, 1.6 VTi 120		<b>F5-1113</b>
Alternator Freewheel Clutch	1.6 16V, 1.6 THP 155, 1.6 VTi 120		<b>F5-1132</b>
Anti-Friction Bearing	1.6 16V, 1.6 HDi, 1.6 HDi 110, 1.6 THP 155, 1.6 VTi 120, 1.8 i 16V, 2.0 HDi 138, 2.0 HDi 150, 2.0 HDi 165, 2.0 i 16V		<b>F8-3012</b> ⊕ ⊕
Top Strut Mounting	1.6 16V, 1.6 HDi, 1.6 HDi 110, 1.6 THP 155, 1.6 VTi 120, 1.8 i 16V, 2.0 HDi 138, 2.0 HDi 150, 2.0 HDi 165, 2.0 i 16V		<b>F8-6058</b> ⊕ ⊕
Control Arm-/Trailing Arm Bush	1.6 16V, 1.6 HDi, 1.6 VTi 120, 1.8 i 16V, 2.0 HDi 138, 2.0 i 16V		<b>F8-6134</b>
Top Strut Mounting	1.6 16V, 1.6 HDi, 1.6 HDi 110, 1.6 THP 155, 1.6 VTi 120, 1.8 i 16V, 2.0 HDi 138, 2.0 HDi 150, 2.0 HDi 165, 2.0 i 16V		<b>F8-6302</b>
Engine Mounting	1.6 16V, 1.8 i 16V, 2.0 i 16V		<b>F8-6500</b> ⊕
Engine Mounting	1.6 HDi	DV6TED4; Automated ; for vehicles with diesel soot filter	<b>F8-6500</b> ⊕
Engine Mounting	2.0 HDi 138	Automated	<b>F8-6500</b> ⊕
Engine Mounting	2.0 HDi 150	DW10CTED4	<b>F8-6500</b> ⊕
Mounting, automatic transmission	1.6 HDi, 1.6 VTi 120		<b>F8-6505</b> ⊕
Spring Cap	1.6 16V, 1.6 HDi, 1.6 HDi 110, 1.6 THP 155, 1.6 VTi 120, 1.8 i 16V, 2.0 HDi 138, 2.0 HDi 150, 2.0 HDi 165, 2.0 i 16V		<b>F8-6562</b>
Stabiliser Mounting	1.6 16V, 1.6 HDi, 1.6 VTi 120, 1.8 i 16V, 2.0 HDi 138, 2.0 i 16V		<b>F8-6594</b> ⊕ ⊕
Belt Pulley, crankshaft	1.6 HDi	Number of Ribs: 6; Orga. → 10555	<b>F8-7082</b>
Rubber Buffer, suspension	1.6 16V, 1.6 HDi, 1.6 HDi 110, 1.6 THP 155, 1.6 VTi 120, 1.8 i 16V, 2.0 HDi 138, 2.0 HDi 150, 2.0 HDi 165, 2.0 i 16V		<b>F8-7585</b> ⊕ ⊕
Belt Pulley, crankshaft	1.6 HDi, 1.6 HDi 110	Number of Ribs: 5; Parameter: 6PK	<b>F8-7645</b>
Engine Mounting	1.6 HDi, 2.0 i 16V		<b>F8-8184</b> ⊕
Bellow, steering	1.6 16V, 1.6 HDi, 1.6 VTi 120, 1.8 i 16V, 2.0 HDi 138, 2.0 HDi 150, 2.0 i 16V	with clamps	<b>LM-10040S</b>

<b>F5-1046</b>	<b>F5-1113</b>	<b>F5-1132</b>	<b>F8-3012</b>	<b>F8-6058</b>	<b>F8-6134</b>	<b>F8-6302</b>
Ref.Nr.: 30667687	Ref.Nr.: 12317576515	Ref.Nr.:	Ref.Nr.: 503527	Ref.Nr.: 5038.F7	Ref.Nr.: 3523.91	Ref.Nr.: 503885
<b>F8-6500</b>	<b>F8-6505</b>	<b>F8-6562</b>	<b>F8-6594</b>	<b>F8-7082</b>	<b>F8-7585</b>	<b>F8-7645</b>
Ref.Nr.: 1844.36	Ref.Nr.: 1844.51	Ref.Nr.: 5033.75	Ref.Nr.: 509488	Ref.Nr.: 0515.R0	Ref.Nr.: 5033.70	Ref.Nr.: 0515.T3
<b>F8-8184</b>	<b>LM-10040S</b>					
Ref.Nr.: 1806.33	Ref.Nr.: 4066.82					

**Article Description****Article Nr.****Fitting Position****C4 AIRCROSS****04/2012 →**

Rubber Buffer, suspension	All Models	Orga.→13175;	<b>F8-7490</b>				
Rubber Buffer, suspension	All Models	Orga.→13114;	<b>F8-7491</b>				
Belt Pulley, crankshaft	HDi 115, Hdi 115 AWC	Number of Ribs: 5; Parameter: 6PK	<b>F8-7645</b>				D=157.75

**C5 I (DC\_)****03/2001 → 08/2004**

Alternator Freewheel Clutch	2.0 HDi , 2.2 HDi		<b>F5-1020</b>				
Alternator Freewheel Clutch	2.0 HDi , 2.2 HDi		<b>F5-1046</b>				
Belt Pulley, crankshaft	2.0 HDi	Orga.→09337	<b>F8-5636</b>				d=30
Belt Pulley, crankshaft	2.0 HDi	Orga.→09365;	<b>F8-5636</b>				d=30
Belt Pulley, crankshaft	2.2 HDi		<b>F8-5636</b>				d=30
Belt Pulley, crankshaft	2.0 HDi	06/2002 →; Orga.09338 →;	<b>F8-5660</b>				
Belt Pulley, crankshaft	2.0 HDi	06/2002 →; Orga.09366 →;	<b>F8-5660</b>				
Belt Pulley, crankshaft	2.0 HDi	Orga.09338 →	<b>F8-5660</b>				
Belt Pulley, crankshaft	2.0 HDi	Orga.09338 →;	<b>F8-5660</b>				
Belt Pulley, crankshaft	2.0 HDi	Orga.09366 →;	<b>F8-5660</b>				
Engine Mounting	2.2 HDi		<b>F8-6236</b>				H1=53; H2=40; d=10; D=70
Engine Mounting	1.8 16V	EW7J4	<b>F8-6500</b>				
Engine Mounting	2.0 16V , 2.0 HDi		<b>F8-6500</b>				
Engine Mounting	2.0 16V HPi	RLZ (EW10D)	<b>F8-6500</b>				
Stabiliser Mounting	All Models		<b>F8-6595</b>				d=23.5
Holder, engine mounting	3.0 V6		<b>F8-7011</b>				d=10; L=53; D=69
Rubber Buffer, suspension	All Models	<b>ST</b>	<b>F8-7672</b>				H=115
Belt Pulley, crankshaft	3.0 V6		<b>F8-7874</b>				
Control Arm-/Trailing Arm Bush	All Models		<b>F8-7912</b>				
Control Arm-/Trailing Arm Bush	All Models		<b>F8-7974</b>				
Engine Mounting	2.0 HDi		<b>F8-8149</b>				
Engine Mounting	2.0 HDi , 2.2 HDi		<b>F8-8167</b>				
Engine Mounting	2.0 16V		<b>F8-8169</b>				
Engine Mounting	3.0 V6		<b>F8-8202</b>				
Suspension Kit	All Models		<b>G8-556</b>				

**C5 I Estate (DE\_)****06/2001 → 08/2004**

Alternator Freewheel Clutch	2.0 HDi , 2.2 HDi		<b>F5-1020</b>				
Alternator Freewheel Clutch	2.0 HDi , 2.2 HDi		<b>F5-1046</b>				
Belt Pulley, crankshaft	2.0 HDi	Orga.→09337	<b>F8-5636</b>				d=30

<b>F5-1020</b>	<b>F5-1046</b>	<b>F8-5636</b>	<b>F8-5660</b>	<b>F8-6236</b>	<b>F8-6500</b>	<b>F8-6595</b>
Ref.Nr.: 31771-68D01	Ref.Nr.: 30667687	Ref.Nr.: 0515P2	Ref.Nr.: 0515R9	Ref.Nr.: 1809.21	Ref.Nr.: 1844.36	Ref.Nr.: 509483
<b>F8-7011</b>	<b>F8-7490</b>	<b>F8-7491</b>	<b>F8-7645</b>	<b>F8-7672</b>	<b>F8-7874</b>	<b>F8-7912</b>
Ref.Nr.: 1809.28	Ref.Nr.: 505443	Ref.Nr.: 516698	Ref.Nr.: 0515.T3	Ref.Nr.: 5033.66	Ref.Nr.: 0515.S2	Ref.Nr.: 3523.AR
<b>F8-7974</b>	<b>F8-8149</b>	<b>F8-8167</b>	<b>F8-8169</b>	<b>F8-8202</b>	<b>G8-556</b>	
Ref.Nr.: 3523.84	Ref.Nr.: 1844.93	Ref.Nr.: 9631575180	Ref.Nr.: 180669	Ref.Nr.: 1844.C0	Ref.Nr.: 75472408	

Article Description



Article Nr.

Fitting Position



<b>C5 I Estate (DE_)</b>			<b>06/2001 → 08/2004</b>		
Belt Pulley, crankshaft	2.0 HDi	Orga. →09365;	<b>F8-5636</b>		d=30
Belt Pulley, crankshaft	2.2 HDi		<b>F8-5636</b>		d=30
Belt Pulley, crankshaft	2.0 HDi	Orga.09338 →	<b>F8-5660</b>		
Belt Pulley, crankshaft	2.0 HDi	Orga.09338 →;	<b>F8-5660</b>		
Belt Pulley, crankshaft	2.0 HDi	Orga.09366 →;	<b>F8-5660</b>		
Engine Mounting	2.2 HDi		<b>F8-6236</b>		H1=53; H2=40; d=10; D=70
Engine Mounting	1.8 16V	EW7J4	<b>F8-6500</b>		
Engine Mounting	2.0 16V , 2.0 16V HPI , 2.0 HDi		<b>F8-6500</b>		
Engine Mounting	2.0 HDi	DW10ATED	<b>F8-6500</b>		
Stabiliser Mounting	All Models		<b>F8-6595</b>		d=23.5
Holder, engine mounting	3.0 V6		<b>F8-7011</b>		d=10; L=53; D=69
Rubber Buffer, suspension	1.8 16V , 2.0 16V , 2.0 16V HPI , 2.0 HDi , 2.2 HDi , 3.0 Carlsson, 3.0 V6	<b>ST</b>	<b>F8-7672</b>		H=115
Belt Pulley, crankshaft	3.0 Carlsson, 3.0 V6		<b>F8-7874</b>		
Control Arm-/Trailing Arm Bush	All Models		<b>F8-7912</b>		
Control Arm-/Trailing Arm Bush	All Models		<b>F8-7974</b>		
Engine Mounting	2.0 HDi		<b>F8-8149</b>		
Engine Mounting	2.0 HDi , 2.2 HDi		<b>F8-8167</b>		
Engine Mounting	2.0 16V		<b>F8-8169</b>		
Engine Mounting	3.0 V6		<b>F8-8202</b>		
Suspension Kit	All Models		<b>G8-556</b>		
<b>C5 II (RC_)</b>			<b>09/2004 →</b>		
Alternator Freewheel Clutch	2.2 HDi		<b>F5-1020</b>		
Alternator Freewheel Clutch	1.6 HDi , 2.0 HDi , 2.2 HDi		<b>F5-1046</b>		
Alternator Freewheel Clutch	1.6 HDi , 2.0 HDi		<b>F5-1048</b>		
Belt Pulley, crankshaft	2.2 HDi		<b>F8-5636</b>		d=30
Engine Mounting	1.8 16V , 2.0 16V , 2.0 HDi , 2.2 HDi		<b>F8-6236</b>		H1=53; H2=40; d=10; D=70
Stabiliser Mounting	1.6 HDi , 1.8 16V , 2.0 16V , 2.0 HDi , 2.2 HDi, 3.0 Carlsson HP, 3.0 V6		<b>F8-6595</b>		d=23.5
Belt Pulley, crankshaft	1.6 HDi	Number of Ribs: 6	<b>F8-7082</b>		Belt Pulley Ø [mm]=152; Mounting points diam.[mm]=30; W=34
Belt Pulley, crankshaft	1.6 HDi	Number of Ribs: 5; Orga.10556 →; Parameter: 6PK	<b>F8-7645</b>		D=157.75
Rubber Buffer, suspension	1.6 HDi , 1.8 16V , 2.0 16V , 2.0 HDi , 2.2 HDi , 3.0 Carlsson HP, 3.0 V6	<b>ST</b>	<b>F8-7672</b>		H=115

<b>F5-1020</b>	<b>F5-1046</b>	<b>F5-1048</b>	<b>F8-5636</b>	<b>F8-5660</b>	<b>F8-6236</b>	<b>F8-6500</b>
Ref.Nr.: 31771-68D01	Ref.Nr.: 30667687	Ref.Nr.: 77363468	Ref.Nr.: 0515P2	Ref.Nr.: 0515R9	Ref.Nr.: 1809.21	Ref.Nr.: 1844.36
<b>F8-6595</b>	<b>F8-7011</b>	<b>F8-7082</b>	<b>F8-7645</b>	<b>F8-7672</b>	<b>F8-7861</b>	<b>F8-7874</b>
Ref.Nr.: 509483	Ref.Nr.: 1809.28	Ref.Nr.: 0515.R0	Ref.Nr.: 0515.T3	Ref.Nr.: 5033.66	Ref.Nr.: 0515 Q8	Ref.Nr.: 0515.S2
<b>F8-7912</b>	<b>F8-7974</b>	<b>F8-8149</b>	<b>F8-8167</b>	<b>F8-8169</b>	<b>F8-8202</b>	<b>G8-556</b>
Ref.Nr.: 3523.AR	Ref.Nr.: 3523.84	Ref.Nr.: 1844.93	Ref.Nr.: 9631575180	Ref.Nr.: 180669	Ref.Nr.: 1844.C0	Ref.Nr.: 75472408

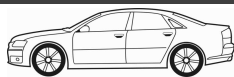
**Article Description****Article Nr.****Fitting Position**

<b>C5 II (RC_)</b>		<b>09/2004 →</b>	
Belt Pulley, crankshaft	2.0 HDi		<b>F8-7861</b>
Belt Pulley, crankshaft	3.0 V6		<b>F8-7874</b>
Control Arm-/Trailing Arm Bush	1.6 HDi , 1.8 16V , 2.0 16V , 2.0 HDi , 2.2 HDi , 3.0 Carlsson HP, 3.0 V6		<b>F8-7912</b>
Control Arm-/Trailing Arm Bush	1.6 HDi , 1.8 16V , 2.0 16V , 2.0 HDi , 2.2 HDi , 3.0 Carlsson HP, 3.0 V6		<b>F8-7974</b>
Engine Mounting	2.0 HDi		<b>F8-8149</b>
Engine Mounting	1.8 16V , 2.0 16V		<b>F8-8169</b>
Engine Mounting	1.6 HDi		<b>F8-8184</b>
Engine Mounting	2.2 HDi , 3.0 V6		<b>F8-8202</b>
Suspension Kit	1.6 HDi , 1.8 16V , 2.0 16V , 2.0 HDi , 2.2 HDi , 3.0 Carlsson HP, 3.0 V6		<b>G8-556</b>
<b>C5 II Break (RE_)</b>		<b>09/2004 →</b>	
Alternator Freewheel Clutch	2.2 HDi		<b>F5-1020</b>
Alternator Freewheel Clutch	1.6 HDi , 2.0 HDi , 2.2 HDi		<b>F5-1046</b>
Alternator Freewheel Clutch	1.6 HDi , 2.0 HDi		<b>F5-1048</b>
Belt Pulley, crankshaft	2.2 HDi		<b>F8-5636</b>
Engine Mounting	1.8 16V , 2.0 16V , 2.0 HDi , 2.2 HDi		<b>F8-6236</b>
Stabiliser Mounting	1.6 HDi , 1.8 16V , 2.0 16V , 2.0 HDi , 2.2 HDi , 3.0, 3.0 V6		<b>F8-6595</b>
Belt Pulley, crankshaft	1.6 HDi	Number of Ribs: 6	<b>F8-7082</b>
Belt Pulley, crankshaft	1.6 HDi	Number of Ribs: 5; Orga.10556→;	<b>F8-7645</b>
Rubber Buffer, suspension	1.6 HDi , 1.8 16V , 2.0 16V , 2.0 HDi , 2.2 HDi , 3.0, 3.0 V6	<b>ST</b>	<b>F8-7672</b>
Belt Pulley, crankshaft	2.0 HDi		<b>F8-7861</b>
Belt Pulley, crankshaft	3.0 V6		<b>F8-7874</b>
Control Arm-/Trailing Arm Bush	1.6 HDi , 1.8 16V , 2.0 16V , 2.0 HDi , 2.2 HDi , 3.0, 3.0 V6		<b>F8-7912</b>
Control Arm-/Trailing Arm Bush	1.6 HDi , 1.8 16V , 2.0 16V , 2.0 HDi , 2.2 HDi , 3.0, 3.0 V6		<b>F8-7974</b>
Engine Mounting	2.0 HDi		<b>F8-8149</b>
Engine Mounting	1.8 16V , 2.0 16V		<b>F8-8169</b>
Engine Mounting	1.6 HDi		<b>F8-8184</b>
Engine Mounting	2.2 HDi , 3.0 V6		<b>F8-8202</b>
Suspension Kit	1.6 HDi , 1.8 16V , 2.0 16V , 2.0 HDi , 2.2 HDi , 3.0, 3.0 V6		<b>G8-556</b>

<b>F5-1020</b>	<b>F5-1046</b>	<b>F5-1048</b>	<b>F8-5636</b>	<b>F8-6236</b>	<b>F8-6595</b>	<b>F8-7082</b>
Ref.Nr.: 31771-68D01	Ref.Nr.: 30667687	Ref.Nr.: 77363468	Ref.Nr.: 0515P2	Ref.Nr.: 1809.21	Ref.Nr.: 509483	Ref.Nr.: 0515.R0
<b>F8-7645</b>	<b>F8-7672</b>	<b>F8-7861</b>		<b>F8-7912</b>	<b>F8-7974</b>	<b>F8-8149</b>
Ref.Nr.: 0515.T3	Ref.Nr.: 5033.66	Ref.Nr.: 0515 Q8	Ref.Nr.: 0515.S2	Ref.Nr.: 3523.AR	Ref.Nr.: 3523.84	Ref.Nr.: 1844.93
<b>F8-8169</b>	<b>F8-8184</b>	<b>F8-8202</b>	<b>G8-556</b>			
Ref.Nr.: 180669	Ref.Nr.: 1806.33	Ref.Nr.: 1844.C0	Ref.Nr.: 75472408			

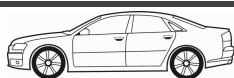
**Article Description**

**Article Nr.**
**Fitting Position**

<b>C5 III (RD_)</b>			<b>02/2008 →</b>		
Alternator Freewheel Clutch	2.0 HDi, 2.0 HDi 140		<b>F5-1046</b>		
Alternator Freewheel Clutch	2.0 HDi 140		<b>F5-1048</b>		
Alternator Freewheel Clutch	2.7 HDi		<b>F5-1109</b>		
Alternator Freewheel Clutch	1.6 THP 155, 1.6 VTi 120		<b>F5-1113</b>		
Alternator Freewheel Clutch	1.6 THP 155, 1.6 VTi 120		<b>F5-1132</b>		
Engine Mounting	1.8 16V, 2.0 16V, 2.0 16V BioFlex, 2.0 HDi		<b>F8-6236</b>		H1=53; H2=40; d=10; D=70
Belt Pulley, crankshaft	1.6 HDi, 1.6 HDi 110	Number of Ribs: 5; Parameter: 6PK	<b>F8-7645</b>		D=157.75
Belt Pulley, crankshaft	3.0 V6		<b>F8-7874</b>		
Engine Mounting	2.0 HDi, 2.0 HDi 140		<b>F8-8149</b>		
Engine Mounting	1.6 THP 155, 1.8 16V, 2.0 16V, 2.0 16V BioFlex, 3.0, 3.0 V6		<b>F8-8169</b>		
Engine Mounting	2.2 HDi, 3.0, 3.0 V6		<b>F8-8202</b>		
<b>C5 III Break (TD_)</b>			<b>02/2008 →</b>		
Alternator Freewheel Clutch	2.0 HDi, 2.0 HDi 140		<b>F5-1046</b>		
Alternator Freewheel Clutch	2.0 HDi 140		<b>F5-1048</b>		
Alternator Freewheel Clutch	2.7 HDi		<b>F5-1109</b>		
Alternator Freewheel Clutch	1.6 THP 155, 1.6 VTi 120		<b>F5-1113</b>		
Alternator Freewheel Clutch	1.6 THP 155, 1.6 VTi 120		<b>F5-1132</b>		
Engine Mounting	1.8 16V, 2.0 16V, 2.0 16V BioFlex, 2.0 HDi		<b>F8-6236</b>		H1=53; H2=40; d=10; D=70
Belt Pulley, crankshaft	1.6 HDi, 1.6 HDi 110	Number of Ribs: 5; Parameter: 6PK	<b>F8-7645</b>		D=157.75
Belt Pulley, crankshaft	3.0 V6		<b>F8-7874</b>		
Engine Mounting	2.0 HDi, 2.0 HDi 140		<b>F8-8149</b>		
Engine Mounting	1.8 16V, 2.0 16V, 2.0 16V BioFlex, 3.0 V6		<b>F8-8169</b>		
Engine Mounting	2.2 HDi, 3.0, 3.0 V6		<b>F8-8202</b>		
<b>C6 (TD_)</b>			<b>09/2005 →</b>		
Alternator Freewheel Clutch	2.7 HDi		<b>F5-1109</b>		
Belt Pulley, crankshaft	3.0 V6		<b>F8-7874</b>		
Engine Mounting	3.0 V6		<b>F8-8169</b>		
Engine Mounting	2.2 HDi, 3.0 V6		<b>F8-8202</b>		
<b>C8 (EA_, EB_)</b>			<b>07/2002 →</b>		
Alternator Freewheel Clutch	2.0 HDi, 2.2 HDi		<b>F5-1020</b>		
Alternator Freewheel Clutch	2.0 HDi, 2.0 HDi 135, 2.2 HDi		<b>F5-1046</b>		
Alternator Freewheel Clutch	2.0 HDi, 2.0 HDi 135, 2.2 HDi		<b>F5-1048</b>		
Anti-Friction Bearing	2.0, 2.0 16V, 2.0 HDi, 2.0 HDi 135, 2.0 HDi 165, 2.2, 2.2 HDi, 3.0 V6		<b>F8-3014</b>		H1=24; H2=46; d1=78; d2=84; D=128

<b>F5-1020</b>	<b>F5-1046</b>	<b>F5-1048</b>	<b>F5-1109</b>	<b>F5-1113</b>	<b>F5-1132</b>	<b>F8-3014</b>
Ref.Nr.: 31771-68D01	Ref.Nr.: 30667687	Ref.Nr.: 77363468	Ref.Nr.:	Ref.Nr.: 12317576515	Ref.Nr.:	Ref.Nr.: 503545
<b>F8-5375</b>	<b>F8-6236</b>	<b>F8-7645</b>	<b>F8-7874</b>	<b>F8-8149</b>	<b>F8-8169</b>	<b>F8-8202</b>
Ref.Nr.: 180906	Ref.Nr.: 1809.21	Ref.Nr.: 0515.T3	Ref.Nr.: 0515.S2	Ref.Nr.: 1844.93	Ref.Nr.: 180669	Ref.Nr.: 1844.C0



**Article Description****Article Nr.****Fitting Position****C8 (EA, EB)****07/2002 →**

Engine Mounting	2.0 HDi, 2.0 HDi 135		<b>F8-5375</b>		H=34; d=12; D=30
Engine Mounting	2.0, 2.0 16V		<b>F8-5569</b>		
Top Strut Mounting	2.0, 2.0 HDi, 2.2, 2.2 HDi, 3.0 V6		<b>F8-5621</b>		
Top Strut Mounting	2.0, 2.0 HDi, 2.2, 2.2 HDi, 3.0 V6		<b>F8-5622</b>		
Belt Pulley, crankshaft	2.0 HDi	Orga.→09519	<b>F8-5636</b>		d=30
Belt Pulley, crankshaft	2.2 HDi	Orga.→10247	<b>F8-5636</b>		d=30
Belt Pulley, crankshaft	2.0 HDi	Orga.09520→	<b>F8-5660</b>		
Belt Pulley, crankshaft	2.2 HDi	Orga.10248→	<b>F8-5660</b>		
Engine Mounting	2.0, 2.0 16V, 2.0 HDi, 2.0 HDi 135, 2.2, 2.2 HDi		<b>F8-6236</b>		H1=53; H2=40; d=10; D=70
Top Strut Mounting	2.0, 2.0 16V, 2.0 HDi, 2.0 HDi 135, 2.2, 2.2 HDi, 3.0 V6		<b>F8-6304</b>		
Control Arm-/Trailing Arm Bush	2.0, 2.0 16V, 2.0 HDi, 2.0 HDi 135, 2.2, 2.2 HDi, 3.0 V6		<b>F8-6439</b>		H=50; d=22.85; Inner Thread 1=M12 x 1,25 RHT F; Inner Thread 2=M12 x 1,25 RHT F; L=82
Engine Mounting	2.0, 2.0 16V, 2.0 HDi, 2.0 HDi 135, 2.2, 2.2 HDi		<b>F8-6507</b>		
Top Strut Mounting	2.0, 2.0 16V, 2.0 HDi, 2.2, 2.2 HDi, 3.0 V6		<b>F8-7164</b>		
Belt Pulley, crankshaft	3.0 V6		<b>F8-7874</b>		
Engine Mounting	2.0 HDi, 2.0 HDi 135, 2.2, 2.2 HDi		<b>F8-8149</b>		
Engine Mounting	2.0 HDi, 2.2 HDi		<b>F8-8167</b>		
Engine Mounting	2.0 16V		<b>F8-8169</b>		
Engine Mounting	2.2 HDi, 3.0 V6		<b>F8-8202</b>		

**C15 (VD-)****10/1984 → 12/2005**

Dust Cover Kit, shock absorber	1.1 i, 1.4, 1.4 E, 1.4 i, 1.8 D		<b>AK-735010</b>		
Dust Cover Kit, shock absorber	1.1, 1.4 E	05/1988 →	<b>AK-735010</b>		
Anti-Friction Bearing	1.0, 1.0 E, 1.1, 1.1 i, 1.3, 1.4, 1.4 E, 1.4 i, 1.8 D, 1.9 D		<b>F8-3012</b>		H=20; d=66; D=100
Engine Mounting	1.8 D		<b>F8-5026</b>		d=10; D=70; Thick. [mm]=40, 53
Control Arm-/Trailing Arm Bush	1.0, 1.1, 1.1 i, 1.4, 1.4 E, 1.4 i, 1.8 D, 1.9 D		<b>F8-5078</b>		d=12; D=36; Thick. [mm]=25
Bellow, driveshaft	1.0, 1.4, 1.4 E, 1.4 i	ch.4196→	<b>F8-5356</b>		D1=72; D219; L=172
Bellow, driveshaft	1.1, 1.1 i	ch.3887, 4196→; ch.→4237	<b>F8-5356</b>		D1=72; D219; L=172
Bellow, driveshaft	1.8 D	ch.3887→	<b>F8-5356</b>		D1=72; D219; L=172
Engine Mounting	1.0 E, 1.8 D		<b>F8-5358</b>		
Engine Mounting	1.1, 1.1 i, 1.3	Orga.→04221	<b>F8-5358</b>		
Engine Mounting	1.4 i	Cast Steel;  TU3M	<b>F8-5358</b>		
Engine Mounting	1.4, 1.4 E	Cast Steel	<b>F8-5358</b>		
Top Strut Mounting	1.0, 1.1, 1.1 i, 1.3, 1.4, 1.4 E, 1.4 i, 1.8 D, 1.9 D		<b>F8-5520</b>		

<b>AK-735010</b>	<b>F8-3012</b>	<b>F8-5026</b>	<b>F8-5078</b>	<b>F8-5356</b>	<b>F8-5358</b>	<b>F8-5375</b>
Ref.Nr.:	Ref.Nr.: 503527	Ref.Nr.: 9606121080	Ref.Nr.: 2523.29	Ref.Nr.: 328769	Ref.Nr.: 184373	Ref.Nr.: 180906
<b>F8-5520</b>	<b>F8-5558</b>	<b>F8-5569</b>	<b>F8-5621</b>	<b>F8-5622</b>	<b>F8-5636</b>	<b>F8-5660</b>
Ref.Nr.: 503518	Ref.Nr.: 1843.97	Ref.Nr.: 9604338880	Ref.Nr.: 1311931080	Ref.Nr.: 503868	Ref.Nr.: 0515P2	Ref.Nr.: 0515R9
<b>F8-6236</b>	<b>F8-6304</b>	<b>F8-6439</b>	<b>F8-6507</b>	<b>F8-7164</b>	<b>F8-7874</b>	<b>F8-8149</b>
Ref.Nr.: 1809.21	Ref.Nr.: 1311930080	Ref.Nr.: 1312317080	Ref.Nr.: 1827.16	Ref.Nr.: 503555	Ref.Nr.: 0515.S2	Ref.Nr.: 1844.93

**Article Description**

**Article Nr.**
**Fitting Position**

<b>C15 (VD_)</b>			<b>10/1984 → 12/2005</b>	
Engine Mounting	1.0 E, 1.1, 1.1 i, 1.3, 1.4, 1.4 E, 1.8 D	Orga.04222→	<b>F8-5558</b>	
Engine Mounting	1.4 i	TU3M; Orga.04222→	<b>F8-5558</b>	
Belt Pulley, crankshaft	1.8 D		<b>F8-5646</b>	
Rubber Buffer, suspension	1.1	E1A	<b>F8-6064</b>	L=79
Rubber Buffer, suspension	1.3, 1.4 i, 1.8 D		<b>F8-6064</b>	L=79
Engine Mounting	1.0 E, 1.1, 1.1 i, 1.4, 1.4 E	Orga.04222→	<b>F8-6487</b>	
Engine Mounting	1.4 i	TU3M; Orga.04222→	<b>F8-6487</b>	
Stabiliser Mounting	1.0, 1.1, 1.4, 1.4 E	Stabi. Diam. [mm]= 22	<b>F8-6794</b>	d=22
Stabiliser Mounting	1.8 D, 1.9 D		<b>F8-6795</b>	D=23; d=22
Engine Mounting	1.0, 1.1, 1.4, 1.4 E		<b>F8-6854</b>	
Control Arm-/Trailing Arm Bush	1.0, 1.1, 1.1 i, 1.3, 1.4, 1.4 E, 1.4 i, 1.8 D		<b>G9-520</b>	H1=34; H2=28; d=10; D=28
Control Arm-/Trailing Arm Bush	1.0, 1.1, 1.1 i, 1.4, 1.4 E, 1.4 i		<b>G9-521</b>	H1=24; H2=42; d=14; D1=21; D2=38
Control Arm-/Trailing Arm Bush	1.1, 1.1 i, 1.4 E, 1.4 i, 1.8 D		<b>G9-523</b>	H=25; d=12; D1=36; D2=47
Repair Kit, link	1.1, 1.1 i, 1.4 E, 1.4 i, 1.8 D		<b>G9-523S</b>	H=25; d=12; D1=36; D2=47
Bellow, steering	1.0, 1.0 E, 1.1, 1.1 i, 1.3, 1.4, 1.4 E, 1.4 i, 1.8 D, 1.9 D	with clamps;	<b>LM-10004S</b>	d1=10; d2=40; L [mm]=175
Bellow, steering	1.0, 1.0 E, 1.1, 1.1 i, 1.3, 1.4, 1.4 E, 1.4 i, 1.8 D, 1.9 D	with clamps;	<b>LM-10004S</b>	d1=10; d2=40; L [mm]=175
Bellow, steering	1.0 E, 1.1, 1.1 i, 1.3, 1.4, 1.4 E, 1.4 i, 1.8 D	with clamps	<b>LM-10039S</b>	d1=40; d2=40; L [mm]=115
<b>C15 Estate</b>			<b>04/1987 → 08/2000</b>	
Anti-Friction Bearing	1.1, 1.4, 1.8 D		<b>F8-3012</b>	H=20; d=66; D=100
Engine Mounting	1.1	Orga.→04221	<b>F8-5358</b>	
Engine Mounting	1.4	Cast Steel	<b>F8-5358</b>	
Engine Mounting	1.8 D		<b>F8-5358</b>	
Engine Mounting	1.1, 1.4, 1.8 D	Orga.04222→	<b>F8-5558</b>	
Belt Pulley, crankshaft	1.8 D		<b>F8-5646</b>	
Rubber Buffer, suspension	1.8 D	Orga.→03221	<b>F8-6064</b>	L=79
Engine Mounting	1.1, 1.4	Orga.04222→	<b>F8-6487</b>	
Bellow, steering	1.1, 1.4, 1.8 D	with clamps;	<b>LM-10004S</b>	d1=10; d2=40; L [mm]=175
Bellow, steering	1.1, 1.4, 1.8 D	with clamps;	<b>LM-10004S</b>	d1=10; d2=40; L [mm]=175
Bellow, steering	1.1, 1.4, 1.8 D	with clamps	<b>LM-10039S</b>	d1=40; d2=40; L [mm]=115
<b>C25 Bus (280_, 290_)</b>			<b>09/1981 → 02/1994</b>	
Dust Cover Kit, shock absorber	1.8 E, 1.9 D, 1.9 TD, 2.0, 2.0 E, 2.5 D, 2.5 D 4x4, 2.5 D Turbo, 2.5 D Turbo 4x4		<b>AK-735070</b>	
Anti-Friction Bearing	1.8 E, 1.9 D, 2.0, 2.0 E, 2.5 D, 2.5 D 4x4, 2.5 D Turbo, 2.5 D Turbo 4x4		<b>F8-3013</b>	H=7; d=49; D=71

<b>AK-735070</b>	<b>F8-3012</b>	<b>F8-3013</b>	<b>F8-5084</b>	<b>F8-5358</b>	<b>F8-5558</b>	<b>F8-5646</b>
Ref.Nr.:	Ref.Nr.: 503527	Ref.Nr.: 503517	Ref.Nr.: 3561.08	Ref.Nr.: 184373	Ref.Nr.: 1843.97	Ref.Nr.: 0515K9
<b>F8-6064</b>	<b>F8-6487</b>	<b>F8-6794</b>	<b>F8-6795</b>	<b>F8-6854</b>	<b>G9-520</b>	<b>G9-521</b>
Ref.Nr.: 5033.26	Ref.Nr.: 184472	Ref.Nr.: 5094.37	Ref.Nr.: 5094.40	Ref.Nr.: 1807.45	Ref.Nr.: 96096727	Ref.Nr.: 91504248
<b>G9-523</b>	<b>G9-523S</b>	<b>LM-10004S</b>	<b>LM-10039S</b>			
Ref.Nr.: 3523.25	Ref.Nr.: 3523.25	Ref.Nr.: 7910030073	Ref.Nr.: 4066.22			

**Article Description****Article Nr.****Fitting Position**

<b>C25 Bus (280_, 290_)</b>			<b>09/1981 → 02/1994</b>		
Tie Bar Bush	1.8 E, 1.9 D, 2.0, 2.5 D, 2.5 D Turbo		<b>F8-5084</b>		H=24.5; H1=20.5; d=22; D=48
Top Strut Mounting	1.8 E, 1.9 D, 2.0, 2.0 E, 2.5 D, 2.5 D 4x4, 2.5 D Turbo, 2.5 D Turbo 4x4		<b>F8-5612</b>		
Belt Pulley, crankshaft	1.9 D		<b>F8-5646</b>		
Mounting, leaf spring	1.8 E, 1.9 D, 2.0, 2.5 D, 2.5 D Turbo		<b>F8-5870</b>		H=72; d=16; D=38
Engine Mounting	1.8 E, 1.9 D, 2.0 E, 2.5 D, 2.5 D 4x4, 2.5 D Turbo, 2.5 D Turbo 4x4		<b>F8-6509</b>		
<b>C25 Box (280_, 290_)</b>			<b>09/1981 → 03/1994</b>		
Dust Cover Kit, shock absorber	2.0	[kg]: 1000, 1400	<b>AK-735070</b>		
Dust Cover Kit, shock absorber	2.0 E	01/1986 →;  [kg]: 1000, 1400	<b>AK-735070</b>		
Top Strut Mounting	1.8, 1.9 D 1400, 1.9 D 4x4, 1.9 DT, 2.0, 2.0 4x4, 2.5 D, 2.5 DT, 2.5 DT 4x4		<b>F8-5612</b>		
Belt Pulley, crankshaft	1.9 D 1400, 1.9 D 4x4, 1.9 DT		<b>F8-5646</b>		
Engine Mounting	1.8, 1.9 D 1400, 1.9 D 4x4, 2.0, 2.0 4x4, 2.5 D		<b>F8-6509</b>		
<b>C25 Platform/Chassis (280_, 290_)</b>			<b>11/1981 → 03/1994</b>		
Dust Cover Kit, shock absorber	2.0	[kg]: 1000, 1400	<b>AK-735070</b>		
Top Strut Mounting	1.8, 1.9, 1.9 DT, 2.0, 2.5 D, 2.5 DT		<b>F8-5612</b>		
Belt Pulley, crankshaft	1.9, 1.9 DT		<b>F8-5646</b>		
Engine Mounting	1.8, 1.9, 2.0, 2.5 D, 2.5 DT		<b>F8-6509</b>		
<b>C-CROSSER (EP_)</b>			<b>02/2007 →</b>		
Alternator Freewheel Clutch	2.2 HDi		<b>F5-1131</b>		
<b>C-CROSSER ENTERPRISE</b>			<b>01/2009 →</b>		
Alternator Freewheel Clutch	2.2 HDi		<b>F5-1131</b>		
<b>C-ELYSEE</b>			<b>11/2012 →</b>		
Belt Pulley, crankshaft	1.6 VTi 115	Number of Ribs: 5; Parameter: 6PK	<b>F8-6394</b>		H=25; d=44.05; Mounting points diam.[mm]=9; D=148; D1=142.9
Engine Mounting	1.6 VTi 115		<b>F8-8141</b>		
<b>DS3</b>			<b>11/2009 → 07/2015</b>		
Alternator Freewheel Clutch	1.4 VTi 95, 1.6 Racing, 1.6 THP 150, 1.6 THP 155, 1.6 VTi 120		<b>F5-1113</b>		
Alternator Freewheel Clutch	1.4 VTi 95, 1.6 Racing, 1.6 THP 155, 1.6 VTi 120		<b>F5-1132</b>		
Anti-Friction Bearing	1.2 VTi 82, 1.4 HDi 70, 1.4 VTi 95, 1.6 HDi 110, 1.6 HDi 115, 1.6 HDi 90, 1.6 Racing, 1.6 THP 150, 1.6 THP 155, 1.6 VTi 120		<b>F8-3012</b>		H=20; d=66; D=100
Spring Cap	1.2 VTi 82, 1.4 HDi 70, 1.4 VTi 95, 1.6 HDi 110, 1.6 HDi 115, 1.6 HDi 90, 1.6 Racing, 1.6 THP 150, 1.6 THP 155, 1.6 VTi 120		<b>F8-6562</b>		
Belt Pulley, crankshaft	1.4 HDi 70, 1.6 HDi 110, 1.6 HDi 90	Number of Ribs: 5; Parameter: 6PK	<b>F8-7645</b>		D=157.75

<b>AK-735070</b>	<b>F5-1113</b>	<b>F5-1131</b>	<b>F5-1132</b>	<b>F8-3012</b>	<b>F8-5084</b>	<b>F8-5612</b>
Ref.Nr.:	Ref.Nr.: 12317576515	Ref.Nr.:	Ref.Nr.:	Ref.Nr.: 503527	Ref.Nr.: 3561.08	Ref.Nr.: 04466980
<b>F8-5646</b>	<b>F8-5870</b>	<b>F8-6394</b>	<b>F8-6509</b>	<b>F8-6562</b>	<b>F8-7645</b>	<b>F8-7660</b>
Ref.Nr.: 0515K9	Ref.Nr.: 04333710	Ref.Nr.: 0515.R8	Ref.Nr.: 1843.61	Ref.Nr.: 5033.75	Ref.Nr.: 0515.T3	Ref.Nr.: 525448
<b>F8-8141</b>						
Ref.Nr.: 180659						

<b>Article Description</b>			<b>Article Nr.</b>	<b>Fitting Position</b>	
----------------------------	--	--	--------------------	-------------------------	--

<b>DS3</b>		<b>11/2009 → 07/2015</b>	
Protective Cap/Bellow, shock absorber	1.2 VTi 82, 1.4 HDi 70, 1.4 VTi 95, 1.4 VTi 95 LPG, 1.4 VTi 98, 1.6 HDi 110, 1.6 HDi 115, 1.6 HDi 90, 1.6 Racing, 1.6 THP 150, 1.6 THP 155, 1.6 VTi 120	ST	F8-7660
Engine Mounting	1.4 HDi 70, 1.4 VTi 95, 1.4 VTi 95 LPG, 1.4 VTi 98, 1.6 VTi 120		F8-8141
<b>DS3 Convertible</b>		<b>01/2013 → 07/2015</b>	
Anti-Friction Bearing	1.2 VTi 82, 1.6 HDi 90, 1.6 THP 150, 1.6 THP 155, 1.6 VTi 120		F8-3012
Spring Cap	1.2 VTi 82, 1.6 HDi 90, 1.6 THP 150, 1.6 THP 155, 1.6 VTi 120		F8-6562
Protective Cap/Bellow, shock absorber	1.2 VTi 82, 1.6 HDi 90, 1.6 THP 150, 1.6 THP 155, 1.6 VTi 120	ST	F8-7660
Engine Mounting	1.6 VTi 120		F8-8141
<b>DS4</b>		<b>04/2011 → 07/2015</b>	
Alternator Freewheel Clutch	1.6 THP 155, 1.6 THP 160, 1.6 THP 200, 1.6 VTi 120		F5-1113
Alternator Freewheel Clutch	1.6 THP 155, 1.6 THP 160, 1.6 THP 200, 1.6 VTi 120		F5-1132
Anti-Friction Bearing	1.6 HDi 110, 1.6 HDi 115, 1.6 HDi 90, 1.6 THP 155, 1.6 THP 160, 1.6 THP 200, 1.6 VTi 120, 2.0 HDi 135, 2.0 HDi 165		F8-3012
Belt Pulley, crankshaft	1.6 HDi 110	Number of Ribs: 5; Parameter: 6PK	F8-7645
Bellow, steering	1.6 HDi 110, 1.6 THP 155, 1.6 THP 200, 1.6 VTi 120, 2.0 HDi 165	with clamps	LM-10040S
<b>DS5</b>		<b>11/2011 → 07/2015</b>	
Alternator Freewheel Clutch	1.6 THP 155		F5-1113
Anti-Friction Bearing	2.0 HDi 165 Hybrid4 4x4		F8-3012
Belt Pulley, crankshaft	1.6 HDi 110	Number of Ribs: 5; Parameter: 6PK	F8-7645
<b>SYNERGIE (22, U6)</b>		<b>06/1994 → 07/2002</b>	
Dust Cover Kit, shock absorber	1.8, 1.9 TD, 2.0, 2.0 16V, 2.0 HDI, 2.0 Turbo C.T., 2.1 TD		AK-735091
Alternator Freewheel Clutch	2.0 HDI		F5-1020
Alternator Freewheel Clutch	2.0 HDI, 2.0 HDI 16V		F5-1046
Anti-Friction Bearing	All Models		F8-3014
Engine Mounting	1.8, 1.9 TD, 2.0, 2.0 16V, 2.0 HDI, 2.0 Turbo C.T., 2.1 TD		F8-5026
Stabiliser Mounting	1.8, 1.9 TD, 2.0, 2.0 16V, 2.0 HDI, 2.0 Turbo C.T., 2.1 TD		F8-5092
Engine Mounting	1.8, 2.0		F8-5569
Top Strut Mounting	1.8, 1.9 TD, 2.0, 2.0 16V, 2.0 HDI, 2.0 Turbo C.T., 2.1 TD		F8-5621

<b>AK-735091</b>	<b>F5-1020</b>	<b>F5-1046</b>	<b>F5-1113</b>	<b>F5-1132</b>	<b>F8-3012</b>	<b>F8-3014</b>
Ref.Nr.: 503339	Ref.Nr.: 31771-68D01	Ref.Nr.: 30667687	Ref.Nr.: 12317576515	Ref.Nr.:	Ref.Nr.: 503527	Ref.Nr.: 503545
<b>F8-5026</b>	<b>F8-5092</b>	<b>F8-5569</b>	<b>F8-5621</b>	<b>F8-5622</b>	<b>F8-6562</b>	<b>F8-7645</b>
Ref.Nr.: 9606121080	Ref.Nr.: 1305782080	Ref.Nr.: 9604338880	Ref.Nr.: 1311931080	Ref.Nr.: 503868	Ref.Nr.: 5033.75	Ref.Nr.: 0515.T3
<b>F8-7660</b>	<b>F8-8141</b>	<b>LM-10040S</b>				
Ref.Nr.: 525448	Ref.Nr.: 180659	Ref.Nr.: 4066.82				

**Article Description****Article Nr.****Fitting Position**

<b>SYNERGIE (22, U6)</b>		<b>06/1994 → 07/2002</b>	
Top Strut Mounting	1.8, 1.9 TD, 2.0, 2.0 16V, 2.0 HDI, 2.0 Turbo C.T., 2.1 TD		<b>F8-5622</b>
Belt Pulley, crankshaft	2.0 HDI		<b>F8-5636</b> d=30
Belt Pulley, crankshaft	2.0 HDI 16V	for vehicles without diesel soot filter	<b>F8-5636</b> d=30
Belt Pulley, crankshaft	1.9 TD	10/1996 →; Number of Ribs: 6	<b>F8-5643</b> Belt Pulley Ø [mm]=156; W=44
Belt Pulley, crankshaft	1.9 TD	Number of Ribs: 6	<b>F8-5643</b> Belt Pulley Ø [mm]=156; W=44
Belt Pulley, crankshaft	2.1 TD		<b>F8-5647</b>
Mounting, axle beam	1.8, 1.9 TD, 2.0, 2.0 16V, 2.0 HDI, 2.0 HDI 16V, 2.0 Turbo C.T., 2.1 TD		<b>F8-5871</b> H1=60; H2=48; d=12; D=46
Rubber Buffer, suspension	1.8, 1.9 TD, 2.0, 2.0 16V, 2.0 HDI, 2.0 HDI 16V, 2.0 Turbo C.T., 2.1 TD		<b>F8-5936</b>
Control Arm-/Trailing Arm Bush	1.8, 1.9 TD, 2.0, 2.0 16V, 2.0 HDI, 2.0 HDI 16V, 2.0 Turbo C.T., 2.1 TD		<b>F8-6153</b>
Control Arm-/Trailing Arm Bush	1.8, 1.9 TD, 2.0, 2.0 16V, 2.0 HDI, 2.0 HDI 16V, 2.0 Turbo C.T., 2.1 TD		<b>F8-6154</b>
Control Arm-/Trailing Arm Bush	1.8, 1.9 TD, 2.0, 2.0 16V, 2.0 HDI, 2.0 HDI 16V, 2.0 Turbo C.T., 2.1 TD		<b>F8-6155</b>
Engine Mounting	1.8, 1.9 TD, 2.0, 2.0 16V, 2.0 HDI, 2.0 HDI 16V, 2.0 Turbo C.T., 2.1 TD		<b>F8-6236</b> H1=53; H2=40; d=10; D=70
Top Strut Mounting	1.8, 1.9 TD, 2.0, 2.0 16V, 2.0 HDI, 2.0 HDI 16V, 2.0 Turbo C.T., 2.1 TD		<b>F8-6304</b>
Control Arm-/Trailing Arm Bush	1.8, 1.9 TD, 2.0, 2.0 Turbo C.T., 2.1 TD		<b>F8-6439</b> H=50; d=22.85; Inner Thread 1=M12 x 1,25 RHT F; Inner Thread 2=M12 x 1,25 RHT F; L=82
Engine Mounting	1.9 TD, 2.0 16V, 2.0 HDI, 2.0 HDI 16V, 2.0 Turbo C.T., 2.1 TD		<b>F8-6507</b>
Engine Mounting	2.0 HDI		<b>F8-6897</b>
Belt Pulley, crankshaft	2.0 16V	10/1998 →; Number of Ribs: 6	<b>F8-7083</b> Belt Pulley Ø [mm]=127; Mounting points diam.[mm]=30; W=38
Top Strut Mounting	1.8, 1.9 TD, 2.0, 2.0 16V, 2.0 HDI, 2.0 Turbo C.T., 2.1 TD		<b>F8-7164</b>
Engine Mounting	2.0 HDI, 2.0 HDI 16V		<b>F8-8149</b>
Engine Mounting	2.0 HDI, 2.0 HDI 16V		<b>F8-8167</b>
Bellow, steering	All Models	with clamps	<b>LM-10022S</b> d1=13; d2=62; L [mm]=210
<b>RELAY Bus (230P)</b>		<b>02/1994 → 04/2002</b>	
Dust Cover Kit, shock absorber	1.9 D, 1.9 TD, 1.9 TD 4x4, 2.0, 2.0 4x4, 2.5 D, 2.5 D 4x4, 2.5 TD, 2.5 TD 4x4, 2.5 TDi, 2.5 TDi 4x4, 2.8 HDi, 2.8 HDi 4x4		<b>AK-735070</b>
Alternator Freewheel Clutch	2.8 D, 2.8 HDi, 2.8 HDi 4x4		<b>F5-1020</b>

<b>AK-735070</b>	<b>F5-1020</b>	<b>F8-3023</b>	<b>F8-5622</b>	<b>F8-5636</b>	<b>F8-5643</b>	<b>F8-5647</b>
Ref.Nr.:	Ref.Nr.: 31771-68D01	Ref.Nr.: 503547	Ref.Nr.: 503868	Ref.Nr.: 0515P2	Ref.Nr.: 96089 38980	Ref.Nr.: 0515J9
<b>F8-5871</b>	<b>F8-5936</b>	<b>F8-6153</b>	<b>F8-6154</b>	<b>F8-6155</b>	<b>F8-6236</b>	<b>F8-6304</b>
Ref.Nr.: 515261	Ref.Nr.: 5033.39	Ref.Nr.: 3520.G9S1	Ref.Nr.: 3521.C9S	Ref.Nr.: 1316735080S	Ref.Nr.: 1809.21	Ref.Nr.: 1311930080
<b>F8-6439</b>	<b>F8-6507</b>	<b>F8-6897</b>	<b>F8-7083</b>	<b>F8-7164</b>	<b>F8-8149</b>	<b>F8-8167</b>
Ref.Nr.: 1312317080	Ref.Nr.: 1827.16	Ref.Nr.: 1827.33	Ref.Nr.: 0515.K6	Ref.Nr.: 503555	Ref.Nr.: 1844.93	Ref.Nr.: 9631575180

Article Description



Article Nr.

Fitting Position



<b>RELAY Bus (230P)</b>		<b>02/1994 → 04/2002</b>	
Anti-Friction Bearing	1.9 D, 1.9 TD, 1.9 TD 4x4, 2.0, 2.0 4x4, 2.5 D, 2.5 D 4x4, 2.5 TD, 2.5 TD 4x4, 2.5 TDi, 2.5 TDi 4x4		F8-3023  ⊕ ⊕ H=9; d=49; D=71
Top Strut Mounting	1.9 D, 1.9 TD, 1.9 TD 4x4, 2.0, 2.0 4x4, 2.5 D, 2.5 D 4x4, 2.5 TD, 2.5 TD 4x4, 2.5 TDi, 2.5 TDi 4x4, 2.8 HDi, 2.8 HDi 4x4	also for special vehicles;	F8-5353  ⊕
Top Strut Mounting	1.9 D, 1.9 TD, 1.9 TD 4x4, 2.0, 2.0 4x4, 2.5 D, 2.5 D 4x4, 2.5 TD, 2.5 TD 4x4, 2.5 TDi, 2.5 TDi 4x4, 2.8 HDi, 2.8 HDi 4x4	also for special vehicles;	F8-5354  ⊕
Belt Pulley, crankshaft	1.9 D	Number of Ribs: 6;	F8-5643 Belt Pulley Ø [mm]=156; W=44
Belt Pulley, crankshaft	1.9 TD	Number of Ribs: 6; Type: 27, 31;	F8-5643 Belt Pulley Ø [mm]=156; W=44
Belt Pulley, crankshaft	1.9 TD, 1.9 TD 4x4	Number of Ribs: 6; Type: 31;	F8-5643 Belt Pulley Ø [mm]=156; W=44
Mounting, leaf spring	1.9 D, 1.9 TD, 2.0, 2.5 D, 2.5 TD, 2.5 TDi, 2.8 D, 2.8 HDi		F8-5897  ⊕ ⊕ H=46.5; d=16; D=40
Mounting, leaf spring	1.9 D, 1.9 TD, 2.0, 2.5 D, 2.5 TD, 2.8 HDi		F8-5898  ⊕ ⊕ H=87; d=16; D=50
Control Arm-/Trailing Arm Bush	1.9 D, 1.9 TD, 1.9 TD 4x4, 2.0, 2.0 4x4, 2.5 D, 2.5 D 4x4, 2.5 TD, 2.5 TD 4x4, 2.5 TDi, 2.5 TDi 4x4, 2.8 HDi, 2.8 HDi 4x4	for OE: 1320755080, 1320756080, 3520.N3, 3520.N4, 3521.J3, 3521.J4	F8-6114  ⊕ ⊕ ⊕ ↓
Control Arm-/Trailing Arm Bush	1.9 D, 1.9 TD, 1.9 TD 4x4, 2.0, 2.0 4x4, 2.5 D, 2.5 D 4x4, 2.5 TD, 2.5 TD 4x4, 2.5 TDi, 2.5 TDi 4x4, 2.8 HDi, 2.8 HDi 4x4		F8-6115  ⊕ ⊕ H=55; d=25.5; D1=56; D2=45
Top Strut Mounting	1.9 D, 1.9 TD, 1.9 TD 4x4, 2.0, 2.0 4x4, 2.5 D, 2.5 D 4x4, 2.5 TD, 2.5 TD 4x4, 2.5 TDi, 2.5 TDi 4x4, 2.8 HDi, 2.8 HDi 4x4		F8-6306  ⊕
Belt Pulley, crankshaft	2.5 D, 2.5 D 4x4, 2.5 TD, 2.5 TD 4x4, 2.5 TDi, 2.5 TDi 4x4		F8-6395
Control Arm-/Trailing Arm Bush	1.9 D, 1.9 TD, 2.0, 2.5 D, 2.5 D 4x4, 2.5 TD, 2.5 TD 4x4, 2.5 TDi, 2.5 TDi 4x4, 2.8 HDi, 2.8 HDi 4x4		F8-6452  ⊕ ⊕ ⊕ ↓
Engine Mounting	1.9 TD, 2.0, 2.5 D, 2.5 D 4x4, 2.5 TD, 2.5 TD 4x4, 2.5 TDi, 2.5 TDi 4x4, 2.8 HDi, 2.8 HDi 4x4		F8-6485  ⊕
Engine Mounting	1.9 TD, 2.0, 2.5 TDi	[kg]: 1800	F8-6520
Engine Mounting	2.5 D, 2.5 TD	[kg]: 1800; Transmission Type: MG5TU	F8-6520
Engine Mounting	2.5 D, 2.5 TD		F8-6888  ⊕
Engine Mounting	1.9 D, 1.9 TD		F8-6891  ⊕
Engine Mounting	2.0	[kg]: 1000, 1400, 1800	F8-6891  ⊕
Engine Mounting	1.9 D, 1.9 TD, 2.5 D, 2.5 TD		F8-6918  ⊕
Engine Mounting	2.0	[kg]: 1000, 1400, 1800	F8-6918  ⊕
Belt Pulley, crankshaft	1.9 D	Number of Ribs: 6	F8-7079 Belt Pulley Ø [mm]=156; Mounting points diam.[mm]=30; W=44.7
Belt Pulley, crankshaft	1.9 TD	09/1998 →; Number of Ribs: 6	F8-7079 Belt Pulley Ø [mm]=156; Mounting points diam.[mm]=30; W=44.7

<b>F8-3023</b>	<b>F8-5353</b>	<b>F8-5354</b>	<b>F8-5643</b>	<b>F8-5897</b>	<b>F8-5898</b>	<b>F8-6114</b>
Ref.Nr.: 503547	Ref.Nr.: 5038.19	Ref.Nr.: 5038.18	Ref.Nr.: 96089 38980	Ref.Nr.: 1304640080	Ref.Nr.: 5131.73	Ref.Nr.: 1320755080-PA
<b>F8-6115</b>	<b>F8-6306</b>	<b>F8-6395</b>	<b>F8-6452</b>	<b>F8-6485</b>	<b>F8-6520</b>	<b>F8-6888</b>
Ref.Nr.: 3523.93	Ref.Nr.: 503547	Ref.Nr.: 0515.H3	Ref.Nr.: 3523.93	Ref.Nr.: 1846.66	Ref.Nr.: 1307908080	Ref.Nr.: 1307907080
<b>F8-6891</b>	<b>F8-6918</b>	<b>F8-7079</b>				
Ref.Nr.: 1307906080	Ref.Nr.: 1310575080	Ref.Nr.: 0515.K4				

**Article Description****Article Nr.****Fitting Position**

<b>RELAY Bus (230P)</b>				<b>02/1994 → 04/2002</b>	
Belt Pulley, crankshaft	1.9 TD	10/1996 →; Number of Ribs: 6	<b>F8-7079</b>		Belt Pulley Ø [mm]=156; Mounting points diam.[mm]=30; W=44.7
Belt Pulley, crankshaft	2.8 HDi, 2.8 HDi 4x4	Number of Ribs: 6	<b>F8-7081</b>		Belt Pulley Ø [mm]=146; W=56
Top Strut Mounting	1.9 D, 1.9 TD, 1.9 TD 4x4, 2.0, 2.0 4x4, 2.5 D, 2.5 D 4x4, 2.5 TD, 2.5 TD 4x4, 2.5 TDi, 2.5 TDi 4x4, 2.8 HDi, 2.8 HDi 4x4		<b>F8-7154</b>		
Belt Pulley, crankshaft	1.9 D, 1.9 TD 4x4		<b>F8-7863</b>		
Belt Pulley, crankshaft	1.9 TD	10/1996 →;	<b>F8-7863</b>		
Top Strut Mounting	1.9 D, 1.9 TD, 1.9 TD 4x4, 2.0, 2.0 4x4, 2.5 D, 2.5 D 4x4, 2.5 TD, 2.5 TD 4x4, 2.5 TDi, 2.5 TDi 4x4	ch.→15547880; not for special purpose vehicles;	<b>F8-8066</b>		
Top Strut Mounting	1.9 D, 1.9 TD, 1.9 TD 4x4, 2.0, 2.0 4x4, 2.5 D, 2.5 D 4x4, 2.5 TD, 2.5 TD 4x4, 2.5 TDi, 2.5 TDi 4x4, 2.8 HDi, 2.8 HDi 4x4	ch.15547881→; not for special purpose vehicles;	<b>F8-8066</b>		
Top Strut Mounting	1.9 D, 1.9 TD, 1.9 TD 4x4, 2.0, 2.0 4x4, 2.5 D, 2.5 D 4x4, 2.5 TD, 2.5 TD 4x4, 2.5 TDi, 2.5 TDi 4x4	ch.→15547880; not for special purpose vehicles;	<b>F8-8067</b>		
Top Strut Mounting	1.9 D, 1.9 TD, 1.9 TD 4x4, 2.0, 2.0 4x4, 2.5 D, 2.5 D 4x4, 2.5 TD, 2.5 TD 4x4, 2.5 TDi, 2.5 TDi 4x4, 2.8 HDi, 2.8 HDi 4x4	ch.15547881→; not for special purpose vehicles;	<b>F8-8067</b>		
Bellow, steering	1.9 D, 1.9 TD, 1.9 TD 4x4, 2.0, 2.0 4x4, 2.5 D, 2.5 D 4x4, 2.5 TD, 2.5 TD 4x4, 2.5 TDi, 2.5 TDi 4x4, 2.8 HDi, 2.8 HDi 4x4	Orga.→13502; with clamps;	<b>LM-10018S</b>		d1=15; d2=54; L [mm]=264

<b>RELAY Box (230L)</b>				<b>02/1994 → 04/2002</b>	
Dust Cover Kit, shock absorber	1.9 D, 1.9 TD, 2.0, 2.0 HDi, 2.5 D, 2.5 D 4x4, 2.5 TD, 2.5 TDi, 2.5 TDi 4x4, 2.8 HDi, 2.8 HDi 4x4	[kg]: 1000, 1400	<b>AK-735070</b>		
Alternator Freewheel Clutch	2.0 HDi, 2.8 D, 2.8 HDi, 2.8 HDi 4x4		<b>F5-1020</b>		
Anti-Friction Bearing	1.9 D, 1.9 TD, 2.0, 2.5 D, 2.5 TD, 2.5 TDi		<b>F8-3023</b>		H=9; d=49; D=71
Top Strut Mounting	1.9 D, 1.9 TD, 2.0, 2.0 HDi, 2.5 D, 2.5 D 4x4, 2.5 TD, 2.5 TDi, 2.5 TDi 4x4, 2.8 HDi, 2.8 HDi 4x4	also for special vehicles;	<b>F8-5353</b>		
Top Strut Mounting	1.9 D, 1.9 TD, 2.0, 2.0 HDi, 2.5 D, 2.5 D 4x4, 2.5 TD, 2.5 TDi, 2.5 TDi 4x4, 2.8 HDi, 2.8 HDi 4x4	also for special vehicles;	<b>F8-5354</b>		
Belt Pulley, crankshaft	1.9 D, 1.9 TD	Number of Ribs: 6; Type: 27;	<b>F8-5643</b>		Belt Pulley Ø [mm]=156; W=44
Mounting, leaf spring	1.9 D, 1.9 TD, 2.0, 2.0 HDi, 2.5 D, 2.5 TD, 2.5 TDi, 2.8 D, 2.8 HDi, 2.8 HDi 4x4		<b>F8-5897</b>		H=46.5; d=16; D=40
Mounting, leaf spring	1.9 D, 1.9 TD, 2.0, 2.5 D, 2.5 TD, 2.5 TDi, 2.8 HDi, 2.8 HDi 4x4		<b>F8-5898</b>		H=87; d=16; D=50
Control Arm-/Trailing Arm Bush	1.9 D, 1.9 TD, 2.0, 2.0 4x4, 2.0 HDi, 2.5 D, 2.5 D 4x4, 2.5 DT 4x4, 2.5 TD, 2.5 TDi, 2.5 TDi 4x4, 2.8 HDi, 2.8 HDi 4x4	for OE: 1320755080, 1320756080, 3520.N3, 3520.N4, 3521.J3, 3521.J4	<b>F8-6114</b>		
Control Arm-/Trailing Arm Bush	1.9 D, 1.9 TD, 2.0, 2.0 4x4, 2.0 HDi, 2.5 D, 2.5 D 4x4, 2.5 DT 4x4, 2.5 TD, 2.5 TDi, 2.5 TDi 4x4, 2.8 HDi, 2.8 HDi 4x4		<b>F8-6115</b>		H=55; d=25.5; D1=56; D2=45

<b>AK-735070</b>	<b>F5-1020</b>	<b>F8-3023</b>	<b>F8-5353</b>	<b>F8-5354</b>	<b>F8-5643</b>	<b>F8-5897</b>
Ref.Nr.:	Ref.Nr.: 31771-68D01	Ref.Nr.: 503547	Ref.Nr.: 5038.19	Ref.Nr.: 5038.18	Ref.Nr.: 96089 38980	Ref.Nr.: 1304640080
<b>F8-5898</b>	<b>F8-6114</b>	<b>F8-6115</b>	<b>F8-6306</b>	<b>F8-7079</b>	<b>F8-7081</b>	<b>F8-7154</b>
Ref.Nr.: 5131.73	Ref.Nr.: 1320755080-PA	Ref.Nr.: 3523.93	Ref.Nr.: 503547	Ref.Nr.: 0515.K4	Ref.Nr.: 0515.T4	Ref.Nr.: 503530
<b>F8-7863</b>	<b>F8-8066</b>	<b>F8-8067</b>	<b>LM-10018S</b>			
Ref.Nr.: 0515K4	Ref.Nr.: 5038.72	Ref.Nr.: 5038.74	Ref.Nr.: 4018.A5			

Article Description



Article Nr.

Fitting Position



## RELAY Box (230L)

02/1994 → 04/2002

Top Strut Mounting	1.9 D, 1.9 TD, 2.0, 2.0 4x4, 2.0 HDI, 2.5 D, 2.5 D 4x4, 2.5 DT 4x4, 2.5 TD, 2.5 TDi, 2.5 TDi 4x4, 2.8 HDI, 2.8 HDi 4x4		<b>F8-6306</b>		
Belt Pulley, crankshaft	2.5 D, 2.5 D 4x4, 2.5 DT 4x4, 2.5 TD, 2.5 TDi, 2.5 TDi 4x4		<b>F8-6395</b>		
Control Arm-/Trailing Arm Bush	1.9 D, 1.9 TD, 2.0, 2.0 4x4, 2.0 HDI, 2.5 D, 2.5 D 4x4, 2.5 DT 4x4, 2.5 TD, 2.5 TDi, 2.5 TDi 4x4, 2.8 HDI, 2.8 HDi 4x4		<b>F8-6452</b>		
Engine Mounting	1.9 D, 1.9 TD, 2.0, 2.0 4x4, 2.0 HDI, 2.5 D, 2.5 D 4x4, 2.5 DT 4x4, 2.5 TD, 2.5 TDi, 2.5 TDi 4x4, 2.8 HDI, 2.8 HDi 4x4		<b>F8-6485</b>		
Engine Mounting	1.9 D, 1.9 TD, 2.0, 2.0 HDI, 2.8 HDi	[kg]: 1800	<b>F8-6520</b>		
Engine Mounting	2.5 D, 2.5 TD	[kg]: 1800; Transmission Type: MG5TU	<b>F8-6520</b>		
Engine Mounting	2.5 D, 2.5 TD		<b>F8-6888</b>		
Engine Mounting	1.9 D, 1.9 TD		<b>F8-6891</b>		
Engine Mounting	2.0	[kg]: 1000, 1400, 1800	<b>F8-6891</b>		
Engine Mounting	1.9 D, 1.9 TD, 2.5 D, 2.5 TD		<b>F8-6918</b>		
Engine Mounting	2.0	[kg]: 1000, 1400, 1800	<b>F8-6918</b>		
Belt Pulley, crankshaft	1.9 D	Number of Ribs: 6	<b>F8-7079</b>		Belt Pulley Ø [mm]=156; Mounting points diam.[mm]=30; W=44.7
Belt Pulley, crankshaft	1.9 TD	09/1998 →; Number of Ribs: 6	<b>F8-7079</b>		Belt Pulley Ø [mm]=156; Mounting points diam.[mm]=30; W=44.7
Belt Pulley, crankshaft	1.9 TD	10/1996 →; Number of Ribs: 6	<b>F8-7079</b>		Belt Pulley Ø [mm]=156; Mounting points diam.[mm]=30; W=44.7
Belt Pulley, crankshaft	2.8 HDi, 2.8 HDi 4x4	Number of Ribs: 6	<b>F8-7081</b>		Belt Pulley Ø [mm]=146; W=56
Top Strut Mounting	1.9 D, 1.9 TD, 2.0, 2.0 4x4, 2.0 HDI, 2.5 D, 2.5 D 4x4, 2.5 DT 4x4, 2.5 TD, 2.5 TDi, 2.5 TDi 4x4, 2.8 HDI, 2.8 HDi 4x4		<b>F8-7154</b>		
Belt Pulley, crankshaft	1.9 D		<b>F8-7863</b>		
Belt Pulley, crankshaft	1.9 D, 1.9 TD	10/1996 →;	<b>F8-7863</b>		
Top Strut Mounting	1.9 D, 1.9 TD, 2.0, 2.0 HDI, 2.5 D, 2.5 D 4x4, 2.5 TD, 2.5 TDi, 2.5 TDi 4x4	ch.→15547880; not for special purpose vehicles;	<b>F8-8066</b>		
Top Strut Mounting	1.9 D, 1.9 TD, 2.0, 2.0 HDI, 2.5 D, 2.5 D 4x4, 2.5 TD, 2.5 TDi, 2.5 TDi 4x4, 2.8 HDI, 2.8 HDi 4x4	ch.15547881→; not for special purpose vehicles;	<b>F8-8066</b>		
Top Strut Mounting	1.9 D, 1.9 TD, 2.0, 2.0 HDI, 2.5 D, 2.5 D 4x4, 2.5 TD, 2.5 TDi, 2.5 TDi 4x4	ch.→15547880; not for special purpose vehicles;	<b>F8-8067</b>		
Top Strut Mounting	1.9 D, 1.9 TD, 2.0, 2.0 HDI, 2.5 D, 2.5 D 4x4, 2.5 TD, 2.5 TDi, 2.5 TDi 4x4, 2.8 HDI, 2.8 HDi 4x4	ch.15547881→; not for special purpose vehicles;	<b>F8-8067</b>		
Bellow, steering	1.9 D, 1.9 TD, 2.0, 2.5 D, 2.5 TD, 2.5 TDi, 2.8 HDi, 2.8 HDi 4x4	Orga.→13502; with clamps;	<b>LM-10018S</b>		d1=15; d2=54; L [mm]=264

<b>F8-6306</b>	<b>F8-6395</b>	<b>F8-6452</b>	<b>F8-6485</b>	<b>F8-6520</b>	<b>F8-6888</b>	<b>F8-6891</b>
Ref.Nr.: 503547	Ref.Nr.: 0515.H3	Ref.Nr.: 3523.93	Ref.Nr.: 1846.66	Ref.Nr.: 1307908080	Ref.Nr.: 1307907080	Ref.Nr.: 1307906080
<b>F8-6918</b>	<b>F8-7079</b>	<b>F8-7081</b>	<b>F8-7154</b>	<b>F8-7863</b>	<b>F8-8066</b>	<b>F8-8067</b>
Ref.Nr.: 1310575080	Ref.Nr.: 0515.K4	Ref.Nr.: 0515.T4	Ref.Nr.: 503530	Ref.Nr.: 0515K4	Ref.Nr.: 5038.72	Ref.Nr.: 5038.74
<b>LM-10018S</b>						
Ref.Nr.: 4018.A5						



**Article Description****Article Nr.****Fitting Position**

<b>RELAY Platform/Chassis (230)</b>			<b>03/1994 → 04/2002</b>	
Dust Cover Kit, shock absorber	1.9 TD, 2.0, 2.5 D, 2.5 D 4x4, 2.5 TD, 2.5 TDi, 2.5 TDi 4x4, 2.8 HDi	[kg]: 1000, 1400	<b>AK-735070</b>	
Alternator Freewheel Clutch	2.8 D, 2.8 HDi		<b>F5-1020</b>	
Anti-Friction Bearing	1.9 TD, 2.0, 2.5 D, 2.5 TD, 2.5 TDi		<b>F8-3023</b>	⊕ ⊕ H=9; d=49; D=71
Top Strut Mounting	1.9 TD, 2.0, 2.5 D, 2.5 D 4x4, 2.5 TD, 2.5 TDi, 2.5 TDi 4x4, 2.8 HDi	also for special vehicles;	<b>F8-5353</b>	⊕
Top Strut Mounting	1.9 TD, 2.0, 2.5 D, 2.5 D 4x4, 2.5 TD, 2.5 TDi, 2.5 TDi 4x4, 2.8 HDi	also for special vehicles;	<b>F8-5354</b>	⊕
Belt Pulley, crankshaft	1.9 TD	Number of Ribs: 6; Type: 31;	<b>F8-5643</b>	Belt Pulley Ø [mm]=156; W=44
Mounting, leaf spring	1.9 TD, 2.0, 2.5 D, 2.5 TD, 2.5 TDi, 2.8 D, 2.8 HDi		<b>F8-5897</b>	⊕ ⊕ H=46.5; d=16; D=40
Mounting, leaf spring	1.9 TD, 2.0, 2.5 D, 2.5 TD, 2.5 TDi		<b>F8-5898</b>	⊕ ⊕ H=87; d=16; D=50
Control Arm-/Trailing Arm Bush	1.9 TD, 2.0, 2.5 D, 2.5 D 4x4, 2.5 TD, 2.5 TDi, 2.5 TDi 4x4, 2.8 HDi	for OE: 1320755080, 1320756080, 3520.N3, 3520.N4, 3521.J3, 3521.J4	<b>F8-6114</b>	⊕ ⊕ ⊕ ↓
Control Arm-/Trailing Arm Bush	1.9 TD, 2.0, 2.5 D, 2.5 D 4x4, 2.5 TD, 2.5 TDi, 2.5 TDi 4x4, 2.8 HDi		<b>F8-6115</b>	⊕ ⊕ H=55; d=25.5; D1=56; D2=45
Top Strut Mounting	1.9 TD, 2.0, 2.5 D, 2.5 D 4x4, 2.5 TD, 2.5 TDi, 2.5 TDi 4x4, 2.8 HDi		<b>F8-6306</b>	⊕
Belt Pulley, crankshaft	2.5 D, 2.5 D 4x4, 2.5 TD, 2.5 TDi, 2.5 TDi 4x4		<b>F8-6395</b>	
Control Arm-/Trailing Arm Bush	1.9 TD, 2.0, 2.5 D, 2.5 D 4x4, 2.5 TD, 2.5 TDi, 2.5 TDi 4x4, 2.8 HDi		<b>F8-6452</b>	⊕ ⊕ ⊕ ↓
Engine Mounting	1.9 TD, 2.0, 2.5 D, 2.5 D 4x4, 2.5 TD, 2.5 TDi, 2.5 TDi 4x4, 2.8 HDi		<b>F8-6485</b>	⊕
Engine Mounting	1.9 TD, 2.0, 2.5 TDi, 2.8 HDi	[kg]: 1800	<b>F8-6520</b>	
Engine Mounting	2.5 D, 2.5 TD	[kg]: 1800; Transmission Type: MG5TU	<b>F8-6520</b>	
Engine Mounting	2.5 D, 2.5 TD		<b>F8-6888</b>	⊕
Engine Mounting	1.9 TD		<b>F8-6891</b>	⊕
Engine Mounting	2.0	[kg]: 1000, 1400, 1800	<b>F8-6891</b>	⊕
Engine Mounting	1.9 TD, 2.5 D, 2.5 TD		<b>F8-6918</b>	⊕
Engine Mounting	2.0	[kg]: 1000, 1400, 1800	<b>F8-6918</b>	⊕
Belt Pulley, crankshaft	1.9 TD	07/1997 →; Number of Ribs: 6	<b>F8-7079</b>	Belt Pulley Ø [mm]=156; Mounting points diam.[mm]=30; W=44.7
Belt Pulley, crankshaft	1.9 TD	10/1996 →; Number of Ribs: 6	<b>F8-7079</b>	Belt Pulley Ø [mm]=156; Mounting points diam.[mm]=30; W=44.7
Belt Pulley, crankshaft	2.8 HDi	Number of Ribs: 6	<b>F8-7081</b>	Belt Pulley Ø [mm]=146; W=56
Top Strut Mounting	1.9 TD, 2.0, 2.5 D, 2.5 D 4x4, 2.5 TD, 2.5 TDi, 2.5 TDi 4x4, 2.8 HDi		<b>F8-7154</b>	⊕
Top Strut Mounting	1.9 TD, 2.0, 2.5 D, 2.5 D 4x4, 2.5 TD, 2.5 TDi	ch.→15547880; not for special purpose vehicles;	<b>F8-8066</b>	⊕

<b>AK-735070</b>	<b>F5-1020</b>	<b>F8-3023</b>	<b>F8-5353</b>	<b>F8-5354</b>	<b>F8-5643</b>	<b>F8-5897</b>
Ref.Nr.:	Ref.Nr.: 31771-68D01	Ref.Nr.: 503547	Ref.Nr.: 5038.19	Ref.Nr.: 5038.18	Ref.Nr.: 96089 38980	Ref.Nr.: 1304640080
<b>F8-5898</b>	<b>F8-6114</b>	<b>F8-6115</b>	<b>F8-6306</b>	<b>F8-6395</b>	<b>F8-6452</b>	<b>F8-6485</b>
Ref.Nr.: 5131.73	Ref.Nr.: 1320755080-PA	Ref.Nr.: 3523.93	Ref.Nr.: 503547	Ref.Nr.: 0515.H3	Ref.Nr.: 3523.93	Ref.Nr.: 1846.66
<b>F8-6520</b>	<b>F8-6888</b>	<b>F8-6891</b>	<b>F8-6918</b>	<b>F8-7079</b>	<b>F8-7081</b>	<b>F8-7154</b>
Ref.Nr.: 1307908080	Ref.Nr.: 1307907080	Ref.Nr.: 1307906080	Ref.Nr.: 1310575080	Ref.Nr.: 0515.K4	Ref.Nr.: 0515.T4	Ref.Nr.: 503530

## Article Description



Article Nr.

Fitting Position



<b>RELAY Platform/Chassis (230)</b>			03/1994 → 04/2002	
Top Strut Mounting	1.9 TD, 2.0, 2.5 D, 2.5 D 4x4, 2.5 TD, 2.5 TDi, 2.5 TDi 4x4, 2.8 HDi	ch.15547881→; not for special purpose vehicles;	<b>F8-8066</b>	
Top Strut Mounting	1.9 TD, 2.0, 2.5 D, 2.5 D 4x4, 2.5 TD, 2.5 TDi	ch.→15547880; not for special purpose vehicles;	<b>F8-8067</b>	
Top Strut Mounting	1.9 TD, 2.0, 2.5 D, 2.5 D 4x4, 2.5 TD, 2.5 TDi, 2.5 TDi 4x4, 2.8 HDi	ch.15547881→; not for special purpose vehicles;	<b>F8-8067</b>	
Bellow, steering	1.9 TD, 2.0, 2.5 D, 2.5 D 4x4, 2.5 TD, 2.5 TDi, 2.5 TDi 4x4, 2.8 HDi	Orga.→13502; with clamps;	<b>LM-10018S</b>	
<b>RELAY Bus (244, Z )</b>			04/2002 →	
Dust Cover Kit, shock absorber	2.0, 2.0 HDi, 2.2 HDi, 2.8 HDi		<b>AK-735070</b>	
Alternator Freewheel Clutch	2.0 HDi, 2.2 HDi, 2.8 HDi, 2.8 HDi All-wheel Drive		<b>F5-1020</b>	
Alternator Freewheel Clutch	2.2 HDi		<b>F5-1046</b>	
Top Strut Mounting	2.2 HDi, 2.8 HDi	also for special vehicles;	<b>F8-5353</b>	
Top Strut Mounting	2.2 HDi, 2.8 HDi	also for special vehicles;	<b>F8-5354</b>	
Belt Pulley, crankshaft	2.2 HDi		<b>F8-5636</b>	
Mounting, leaf spring	2.0, 2.0 bivalent, 2.2 HDi, 2.8 HDi, 2.8 HDi All-wheel Drive		<b>F8-5897</b>	
Mounting, leaf spring	2.2 HDi, 2.8 HDi		<b>F8-5898</b>	
Control Arm-/Trailing Arm Bush	2.0, 2.0 bivalent, 2.0 HDi, 2.2 HDi, 2.8 HDi	ch.→17226522; for OE: 1320755080, 1320756080, 3520.N3, 3520.N4, 3521.J3, 3521.J4	<b>F8-6114</b>	
Control Arm-/Trailing Arm Bush	2.0, 2.0 HDi, 2.2 HDi, 2.8 HDi		<b>F8-6115</b>	
Control Arm-/Trailing Arm Bush	2.0, 2.0 HDi, 2.2 HDi, 2.8 HDi		<b>F8-6452</b>	
Engine Mounting	2.0, 2.0 HDi, 2.2 HDi, 2.8 HDi		<b>F8-6485</b>	
Control Arm-/Trailing Arm Bush	2.0, 2.0 bivalent, 2.0 HDi, 2.2 HDi, 2.8 HDi	ch.17226523→; for OE: 3520.N3, 3520.N4, 3521.J3, 3521.J4	<b>F8-6773</b>	
Engine Mounting	2.0		<b>F8-6918</b>	
Engine Mounting	2.0 HDi, 2.2 HDi	Orga.09079→	<b>F8-6918</b>	
Belt Pulley, crankshaft	2.8 HDi	Number of Ribs: 6	<b>F8-7081</b>	
Top Strut Mounting	2.0, 2.0 bivalent, 2.0 HDi, 2.2 HDi, 2.8 HDi	not for special purpose vehicles;	<b>F8-8066</b>	
Top Strut Mounting	2.0, 2.0 bivalent, 2.0 HDi, 2.2 HDi, 2.8 HDi	not for special purpose vehicles;	<b>F8-8067</b>	
<b>RELAY Box (244)</b>			04/2002 →	
Dust Cover Kit, shock absorber	All Models	[kg]: 1000, 1400	<b>AK-735070</b>	
Alternator Freewheel Clutch	2.0 HDi, 2.2 HDi, 2.8 HDi, 2.8 HDi 4x4		<b>F5-1020</b>	
Alternator Freewheel Clutch	2.0 HDi		<b>F5-1046</b>	
Top Strut Mounting	2.0, 2.0 HDi, 2.2 HDi, 2.8 HDi, 2.8 HDi 4x4	also for special vehicles;	<b>F8-5353</b>	
Top Strut Mounting	2.0, 2.0 HDi, 2.2 HDi, 2.8 HDi, 2.8 HDi 4x4	also for special vehicles;	<b>F8-5354</b>	

<b>AK-735070</b>	<b>F5-1020</b>	<b>F5-1046</b>	<b>F8-5353</b>	<b>F8-5354</b>	<b>F8-5636</b>	<b>F8-5897</b>
Ref.Nr.:	Ref.Nr.: 31771-68D01	Ref.Nr.: 30667687	Ref.Nr.: 5038.19	Ref.Nr.: 5038.18	Ref.Nr.: 0515P2	Ref.Nr.: 1304640080
<b>F8-5898</b>	<b>F8-6114</b>	<b>F8-6115</b>	<b>F8-6452</b>	<b>F8-6485</b>	<b>F8-6773</b>	<b>F8-6918</b>
Ref.Nr.: 5131.73	Ref.Nr.: 1320755080-PA	Ref.Nr.: 3523.93	Ref.Nr.: 3523.93	Ref.Nr.: 1846.66	Ref.Nr.: 1338373080	Ref.Nr.: 1310575080
<b>F8-7081</b>	<b>F8-8066</b>	<b>F8-8067</b>	<b>LM-10018S</b>			
Ref.Nr.: 0515.T4	Ref.Nr.: 5038.72	Ref.Nr.: 5038.74	Ref.Nr.: 4018.A5			

**Article Description****Article Nr.****Fitting Position**

<b>RELAY Box (244)</b>		<b>04/2002 →</b>			
Belt Pulley, crankshaft	2.2 HDi		<b>F8-5636</b>		d=30
Mounting, leaf spring	All Models		<b>F8-5897</b>		H=46.5; d=16; D=40
Mounting, leaf spring	2.0, 2.0 HDi, 2.2 HDi, 2.8 HDi, 2.8 HDi 4x4		<b>F8-5898</b>		H=87; d=16; D=50
Control Arm-/Trailing Arm Bush	All Models	ch.→17226522; for OE: 1320755080, 1320756080, 3520.N3, 3520.N4, 3521.J3, 3521.J4	<b>F8-6114</b>		
Control Arm-/Trailing Arm Bush	2.0, 2.0 bivalent, 2.0 HDi, 2.2 HDi, 2.8 HDi, 2.8 HDi 4x4		<b>F8-6115</b>		H=55; d=25.5; D1=56; D2=45
Control Arm-/Trailing Arm Bush	All Models		<b>F8-6452</b>		
Engine Mounting	2.0 HDi	DW10TD	<b>F8-6485</b>		
Engine Mounting	2.0, 2.0 bivalent, 2.2 HDi, 2.8 HDi		<b>F8-6485</b>		
Control Arm-/Trailing Arm Bush	All Models	ch.17226523→; for OE: 3520.N3, 3520.N4, 3521.J3, 3521.J4	<b>F8-6773</b>		
Engine Mounting	2.0		<b>F8-6918</b>		
Engine Mounting	2.0 HDi	DW10TD; Orga.09079→	<b>F8-6918</b>		
Engine Mounting	2.2 HDi	Orga.09079→	<b>F8-6918</b>		
Belt Pulley, crankshaft	2.8 HDi, 2.8 HDi 4x4	Number of Ribs: 6	<b>F8-7081</b>		Belt Pulley Ø [mm]=146; W=56
Top Strut Mounting	All Models	not for special purpose vehicles;	<b>F8-8066</b>		
Top Strut Mounting	All Models	not for special purpose vehicles;	<b>F8-8067</b>		
<b>RELAY Platform/Chassis (244)</b>		<b>02/2002 → 06/2006</b>			
Dust Cover Kit, shock absorber	2.0 HDi, 2.2 HDi 16V, 2.8 HDi	[kg]: 1000, 1400	<b>AK-735070</b>		
Alternator Freewheel Clutch	All Models		<b>F5-1020</b>		
Alternator Freewheel Clutch	2.0 HDi		<b>F5-1046</b>		
Top Strut Mounting	2.0 HDi, 2.2 HDi 16V, 2.8 HDi	also for special vehicles;	<b>F8-5353</b>		
Top Strut Mounting	2.0 HDi, 2.2 HDi 16V, 2.8 HDi	also for special vehicles;	<b>F8-5354</b>		
Belt Pulley, crankshaft	2.2 HDi 16V		<b>F8-5636</b>		d=30
Mounting, leaf spring	All Models		<b>F8-5897</b>		H=46.5; d=16; D=40
Mounting, leaf spring	2.0 HDi, 2.2 HDi 16V, 2.8 HDi		<b>F8-5898</b>		H=87; d=16; D=50
Control Arm-/Trailing Arm Bush	All Models	ch.→17226522; for OE: 1320755080, 1320756080, 3520.N3, 3520.N4, 3521.J3, 3521.J4	<b>F8-6114</b>		
Control Arm-/Trailing Arm Bush	2.0 HDi, 2.2 HDi 16V, 2.8 HDi		<b>F8-6115</b>		H=55; d=25.5; D1=56; D2=45
Control Arm-/Trailing Arm Bush	2.0 HDi, 2.2 HDi 16V, 2.8 HDi		<b>F8-6452</b>		
Engine Mounting	All Models		<b>F8-6485</b>		
Control Arm-/Trailing Arm Bush	All Models	ch.17226523→; for OE: 3520.N3, 3520.N4, 3521.J3, 3521.J4	<b>F8-6773</b>		

<b>AK-735070</b>	<b>F5-1020</b>	<b>F5-1046</b>	<b>F8-5353</b>	<b>F8-5354</b>	<b>F8-5636</b>	<b>F8-5897</b>
Ref.Nr.:	Ref.Nr.: 31771-68D01	Ref.Nr.: 30667687	Ref.Nr.: 5038.19	Ref.Nr.: 5038.18	Ref.Nr.: 0515P2	Ref.Nr.: 1304640080
<b>F8-5898</b>	<b>F8-6114</b>	<b>F8-6115</b>	<b>F8-6452</b>	<b>F8-6485</b>	<b>F8-6773</b>	<b>F8-6918</b>
Ref.Nr.: 5131.73	Ref.Nr.: 1320755080-PA	Ref.Nr.: 3523.93	Ref.Nr.: 3523.93	Ref.Nr.: 1846.66	Ref.Nr.: 1338373080	Ref.Nr.: 1310575080
<b>F8-7081</b>	<b>F8-8066</b>	<b>F8-8067</b>				
Ref.Nr.: 0515.T4	Ref.Nr.: 5038.72	Ref.Nr.: 5038.74				

Article Description



Article Nr.

Fitting Position



## RELAY Platform/Chassis (244)

02/2002 → 06/2006

Engine Mounting	2.0 HDi, 2.2 HDi 16V	Orga.09079→	<b>F8-6918</b>	⊕	
Belt Pulley, crankshaft	2.8 HDi, 2.8 HDi 4x4	Number of Ribs: 6	<b>F8-7081</b>		Belt Pulley Ø [mm]=146; W=56
Top Strut Mounting	2.0 HDi, 2.2 HDi 16V, 2.8 HDi	not for special purpose vehicles;	<b>F8-8066</b>		
Top Strut Mounting	2.0 HDi, 2.2 HDi 16V, 2.8 HDi	not for special purpose vehicles;	<b>F8-8067</b>		

## RELAY Bus

04/2006 →

Alternator Freewheel Clutch	2.2 HDi 100, 2.2 HDi 110, 2.2 HDi 120, 2.2 HDi 130, 2.2 HDi 150		<b>F5-1125</b>		
Alternator Freewheel Clutch	3.0 HDi 155, 3.0 HDi 160, 3.0 HDi 180		<b>F5-1148</b>		
Top Strut Mounting	2.2 HDi 100, 2.2 HDi 120, 3.0 HDi 160		<b>F8-6610</b>		
Top Strut Mounting	2.2 HDi 100, 2.2 HDi 120, 3.0 HDi 160		<b>F8-6611</b>		
Engine Mounting	2.2 HDi 100, 2.2 HDi 110, 2.2 HDi 120, 2.2 HDi 130, 2.2 HDi 150		<b>F8-6612</b>		
Engine Mounting	2.2 HDi 100, 2.2 HDi 120		<b>F8-6614</b>	↓	
Mounting, manual transmission	3.0 HDi 155, 3.0 HDi 160, 3.0 HDi 180		<b>F8-6712</b>	↓	
Top Strut Mounting	2.2 HDi 100, 2.2 HDi 120, 3.0 HDi 160		<b>F8-7467</b>		
Top Strut Mounting	2.2 HDi 100, 2.2 HDi 120, 3.0 HDi 160		<b>F8-7468</b>		
Mounting, leaf spring	2.2 HDi 100, 2.2 HDi 110, 2.2 HDi 120, 2.2 HDi 130, 2.2 HDi 150, 3.0 HDi 155, 3.0 HDi 160, 3.0 HDi 180		<b>F8-7790</b>		H=43; d=28; D=50
Mounting, leaf spring	2.2 HDi 100, 2.2 HDi 110, 2.2 HDi 120, 2.2 HDi 130, 2.2 HDi 150, 3.0 HDi 155, 3.0 HDi 160, 3.0 HDi 180		<b>F8-7791</b>		d=16,5; L=86,9; D=66,7

## RELAY Van

04/2006 →

Alternator Freewheel Clutch	2.2 HDi 100, 2.2 HDi 110, 2.2 HDi 120, 2.2 HDi 130, 2.2 HDi 150, 3.0 HDi 160		<b>F5-1125</b>		
Alternator Freewheel Clutch	3.0 HDi 145, 3.0 HDi 155, 3.0 HDi 160, 3.0 HDi 180		<b>F5-1148</b>		
Engine Mounting	2.2 HDi 100, 2.2 HDi 120, 3.0 HDi 160		<b>F8-6485</b>	⊕	
Top Strut Mounting	2.2 HDi 100, 2.2 HDi 120, 3.0 HDi 160		<b>F8-6610</b>		
Top Strut Mounting	2.2 HDi 100, 2.2 HDi 120, 3.0 HDi 160		<b>F8-6611</b>		
Engine Mounting	2.2 HDi 100, 2.2 HDi 110, 2.2 HDi 120, 2.2 HDi 130, 2.2 HDi 150		<b>F8-6612</b>		
Engine Mounting	2.2 HDi 100, 2.2 HDi 120		<b>F8-6614</b>	↓	
Mounting, manual transmission	3.0 HDi 155, 3.0 HDi 160, 3.0 HDi 180		<b>F8-6712</b>	↓	
Top Strut Mounting	2.2 HDi 100, 2.2 HDi 120, 3.0 HDi 160		<b>F8-7467</b>		
Top Strut Mounting	2.2 HDi 100, 2.2 HDi 120, 3.0 HDi 160		<b>F8-7468</b>		
Mounting, leaf spring	All Models		<b>F8-7790</b>		H=43; d=28; D=50
Mounting, leaf spring	All Models		<b>F8-7791</b>		d=16,5; L=86,9; D=66,7

<b>F5-1125</b>	<b>F5-1148</b>	<b>F8-6485</b>	<b>F8-6610</b>	<b>F8-6611</b>	<b>F8-6612</b>	<b>F8-6614</b>
Ref.Nr.: 77364082	Ref.Nr.: 77364797	Ref.Nr.: 1846.66	Ref.Nr.: 5038.A4	Ref.Nr.: 1350788080	Ref.Nr.: 1343631080	Ref.Nr.: 1348993080
<b>F8-6712</b>	<b>F8-6918</b>	<b>F8-7081</b>	<b>F8-7467</b>	<b>F8-7468</b>	<b>F8-7790</b>	<b>F8-7791</b>
Ref.Nr.: 1352888080	Ref.Nr.: 1310575080	Ref.Nr.: 0515.T4	Ref.Nr.: 5038E3	Ref.Nr.: 503447	Ref.Nr.: 5131.F6	Ref.Nr.: 5102.P8
<b>F8-8066</b>	<b>F8-8067</b>					
Ref.Nr.: 5038.72	Ref.Nr.: 5038.74					

**Article Description****Article Nr.****Fitting Position****RELAY Platform/Chassis****04/2006** →

Alternator Freewheel Clutch	2.2 HDi 100, 2.2 HDi 110, 2.2 HDi 120, 2.2 HDi 130, 2.2 HDi 150		<b>F5-1125</b>		
Alternator Freewheel Clutch	3.0 HDi 145, 3.0 HDi 160, 3.0 HDi 180		<b>F5-1148</b>		
Engine Mounting	2.2 HDi 100, 2.2 HDi 120, 3.0 HDi 160		<b>F8-6485</b>	⊕	
Top Strut Mounting	2.2 HDi 100, 2.2 HDi 120, 3.0 HDi 160		<b>F8-6610</b>	⊕	
Top Strut Mounting	2.2 HDi 100, 2.2 HDi 120, 3.0 HDi 160		<b>F8-6611</b>	⊕	
Engine Mounting	2.2 HDi 100, 2.2 HDi 110, 2.2 HDi 120, 2.2 HDi 130, 2.2 HDi 150		<b>F8-6612</b>		
Engine Mounting	2.2 HDi 100, 2.2 HDi 120		<b>F8-6614</b>	↓	
Mounting, manual transmission	3.0 HDi 145, 3.0 HDi 160, 3.0 HDi 180		<b>F8-6712</b>	↓	
Top Strut Mounting	2.2 HDi 100, 2.2 HDi 120, 3.0 HDi 160		<b>F8-7467</b>	⊕	
Top Strut Mounting	2.2 HDi 100, 2.2 HDi 120, 3.0 HDi 160		<b>F8-7468</b>	⊕	
Mounting, leaf spring	All Models		<b>F8-7790</b>		H=43; d=28; D=50
Mounting, leaf spring	All Models		<b>F8-7791</b>		d=16,5; L=86,9; D=66,7
Belt Pulley, crankshaft	2.2 HDi 100, 2.2 HDi 120	Number of Ribs: 5; Number of Ribs 2: 3; Parameter: 4PK, 6PK	<b>F8-8112</b>		

**DISPATCH****01/2007** →

Alternator Freewheel Clutch	1.6 HDi 90, 2.0 HDi 120, 2.0 HDi 140		<b>F5-1046</b>		
Alternator Freewheel Clutch	1.6 HDi 90, 2.0 HDi 120, 2.0 HDi 140		<b>F5-1048</b>		
Anti-Friction Bearing	1.6 HDi 90, 2.0 HDi 120, 2.0 HDi 125, 2.0 HDi 140, 2.0 HDi 165, 2.0 HDi 95, 2.0 i		<b>F8-3014</b>		H1=24; H2=46; d1=78; d2=84; D=128
Engine Mounting	2.0 HDi 120, 2.0 HDi 140		<b>F8-5375</b>		H=34; d=12; D=30
Engine Mounting	1.6 HDi 90, 2.0 i		<b>F8-5569</b>	⊕	
Control Arm-/Trailing Arm Bush	1.6 HDi 90, 2.0 HDi 120, 2.0 HDi 140, 2.0 i		<b>F8-6153</b>	⊕ ⊕	
Control Arm-/Trailing Arm Bush	1.6 HDi 90, 2.0 HDi 120, 2.0 HDi 140, 2.0 i		<b>F8-6154</b>	⊕	
Control Arm-/Trailing Arm Bush	1.6 HDi 90, 2.0 HDi 120, 2.0 HDi 140, 2.0 i		<b>F8-6155</b>	⊕	
Engine Mounting	2.0 HDi 120, 2.0 HDi 140, 2.0 i		<b>F8-6236</b>	⊕	H1=53; H2=40; d=10; D=70
Engine Mounting	2.0 HDi 120, 2.0 HDi 140		<b>F8-6507</b>	⊕	
Belt Pulley, crankshaft	1.6 HDi 90	Number of Ribs: 5; Parameter: 6PK	<b>F8-7645</b>		D=157.75
Engine Mounting	2.0 HDi 120, 2.0 HDi 140		<b>F8-8149</b>	⊕	
Engine Mounting	2.0 i		<b>F8-8169</b>	⊕	
Engine Mounting	1.6 HDi 90		<b>F8-8184</b>	⊕	

**DISPATCH (U6U)****10/1995** → **12/2006**

Dust Cover Kit, shock absorber	1.6, 1.9 D, 1.9 D 70, 1.9 TD, 2.0, 2.0 HDi 110, 2.0 HDi 95, 2.0 i 16V		<b>AK-735091</b>	⊕ ⊕	
--------------------------------	---	--	------------------	-----	--

<b>AK-735091</b>	<b>F5-1020</b>	<b>F5-1046</b>	<b>F5-1048</b>	<b>F5-1125</b>	<b>F5-1148</b>	<b>F8-3014</b>
Ref.Nr.: 503339	Ref.Nr.: 31771-68D01	Ref.Nr.: 30667687	Ref.Nr.: 77363468	Ref.Nr.: 77364082	Ref.Nr.: 77364797	Ref.Nr.: 503545
<b>F8-5375</b>	<b>F8-5569</b>	<b>F8-6153</b>	<b>F8-6154</b>	<b>F8-6155</b>	<b>F8-6236</b>	<b>F8-6485</b>
Ref.Nr.: 180906	Ref.Nr.: 9604338880	Ref.Nr.: 3520.G9S1	Ref.Nr.: 3521.C9S	Ref.Nr.: 1316735080S	Ref.Nr.: 1809.21	Ref.Nr.: 1846.66
<b>F8-6507</b>	<b>F8-6610</b>	<b>F8-6611</b>	<b>F8-6612</b>	<b>F8-6614</b>	<b>F8-6712</b>	<b>F8-7467</b>
Ref.Nr.: 1827.16	Ref.Nr.: 5038.A4	Ref.Nr.: 1350788080	Ref.Nr.: 1343631080	Ref.Nr.: 1348993080	Ref.Nr.: 1352888080	Ref.Nr.: 5038E3

Article Description



Article Nr.

Fitting Position



DISPATCH (U6U)		10/1995 → 12/2006	
Alternator Freewheel Clutch	2.0 HDi 110		<b>F5-1020</b>
Alternator Freewheel Clutch	1.9 D 70, 1.9 TD, 2.0 HDi 110, 2.0 HDi 95		<b>F5-1046</b>
Anti-Friction Bearing	All Models		<b>F8-3014</b>
Stabiliser Mounting	1.6, 1.9 D, 1.9 D 70, 1.9 TD, 2.0, 2.0 HDi 110, 2.0 HDi 95, 2.0 i 16V		<b>F8-5092</b>
Engine Mounting	1.6, 1.9 D, 1.9 D 70, 1.9 TD, 2.0		<b>F8-5569</b>
Top Strut Mounting	1.6, 1.9 D, 1.9 D 70, 1.9 TD, 2.0, 2.0 HDi 110, 2.0 HDi 95, 2.0 i 16V		<b>F8-5621</b>
Top Strut Mounting	1.6, 1.9 D, 1.9 D 70, 1.9 TD, 2.0, 2.0 HDi 110, 2.0 HDi 95, 2.0 i 16V		<b>F8-5622</b>
Belt Pulley, crankshaft	2.0 HDi 110	Orga. →09519	<b>F8-5636</b> d=30
Belt Pulley, crankshaft	1.9 D, 1.9 TD	Number of Ribs: 6	<b>F8-5643</b> Belt Pulley Ø [mm]=156; W=44
Belt Pulley, crankshaft	1.9 D 70	ch. →09894;	<b>F8-5659</b>
Belt Pulley, crankshaft	2.0 HDi 110, 2.0 HDi 95	12/2003 →	<b>F8-5660</b>
Mounting, axle beam	1.6, 1.9 D, 1.9 D 70, 1.9 TD, 2.0, 2.0 HDi 110, 2.0 HDi 95, 2.0 i 16V, 2.2 HDi		<b>F8-5871</b> H1=60; H2=48; d=12; D=46
Rubber Buffer, suspension	1.6, 1.9 D, 1.9 TD, 2.0, 2.0 HDi 110, 2.0 HDi 95, 2.2 HDi		<b>F8-5936</b>
Rubber Buffer, suspension	1.9 D 70	DW8	<b>F8-5936</b>
Control Arm-/Trailing Arm Bush	1.6, 1.9 D, 1.9 D 70, 1.9 TD, 2.0, 2.0 HDi 110, 2.2 HDi		<b>F8-6153</b>
Control Arm-/Trailing Arm Bush	1.6, 1.9 D, 1.9 D 70, 1.9 TD, 2.0, 2.0 HDi 110, 2.2 HDi		<b>F8-6154</b>
Control Arm-/Trailing Arm Bush	1.6, 1.9 D, 1.9 D 70, 1.9 TD, 2.0, 2.0 HDi 110, 2.2 HDi		<b>F8-6155</b>
Engine Mounting	1.9 D, 1.9 D 70, 1.9 TD, 2.0, 2.0 HDi 110		<b>F8-6236</b> H1=53; H2=40; d=10; D=70
Top Strut Mounting	1.6, 1.9 D, 1.9 D 70, 1.9 TD, 2.0, 2.0 HDi 110, 2.0 HDi 95, 2.0 i 16V, 2.2 HDi		<b>F8-6304</b>
Control Arm-/Trailing Arm Bush	1.6, 1.9 D, 1.9 TD		<b>F8-6439</b> H=50; d=22.85; Inner Thread 1=M12 x 1,25 RHT F; Inner Thread 2=M12 x 1,25 RHT F; L=82
Engine Mounting	2.0, 2.0 HDi 110, 2.0 HDi 95		<b>F8-6507</b>
Top Strut Mounting	1.6, 1.9 D, 1.9 D 70, 1.9 TD, 2.0, 2.0 HDi 110, 2.0 HDi 95, 2.0 i 16V		<b>F8-7164</b>
Belt Pulley, crankshaft	1.9 D 70	Orga.09895→;	<b>F8-7862</b>
Engine Mounting	2.0 HDi 110, 2.0 HDi 95		<b>F8-8149</b>
Engine Mounting	1.9 D 70, 2.0 HDi 110, 2.0 HDi 95		<b>F8-8167</b>
Bellow, steering	1.6, 1.9 D, 1.9 D 70, 1.9 TD, 2.0, 2.0 HDi 110, 2.0 HDi 95, 2.0 i 16V, 2.2 HDi	with clamps	<b>LM-10022S</b> d1=13; d2=62; L [mm]=210

<b>F5-1020</b>	<b>F5-1046</b>	<b>F8-3014</b>	<b>F8-5092</b>	<b>F8-5569</b>	<b>F8-5621</b>	<b>F8-5622</b>
Ref.Nr.: 31771-68D01	Ref.Nr.: 30667687	Ref.Nr.: 503545	Ref.Nr.: 1305782080	Ref.Nr.: 9604338880	Ref.Nr.: 1311931080	Ref.Nr.: 503868
<b>F8-5636</b>	<b>F8-5643</b>	<b>F8-5659</b>	<b>F8-5660</b>	<b>F8-5871</b>	<b>F8-5936</b>	<b>F8-6153</b>
Ref.Nr.: 0515P2	Ref.Nr.: 96089 38980	Ref.Nr.: 0515Q6	Ref.Nr.: 0515R9	Ref.Nr.: 515261	Ref.Nr.: 5033.39	Ref.Nr.: 3520.G9S1
<b>F8-6154</b>	<b>F8-6155</b>	<b>F8-6236</b>	<b>F8-6304</b>	<b>F8-6439</b>	<b>F8-6507</b>	<b>F8-7164</b>
Ref.Nr.: 3521.C9S	Ref.Nr.: 1316735080S	Ref.Nr.: 1809.21	Ref.Nr.: 1311930080	Ref.Nr.: 1312317080	Ref.Nr.: 1827.16	Ref.Nr.: 503555



Article Description



Article Nr.

Fitting Position



DISPATCH Van (BS_, BT_, BY_, BZ_)			10/1995 → 10/2006	
Dust Cover Kit, shock absorber	1.6 i, 1.9 D 70, 1.9 TD, 2.0 HDi 110, 2.0 HDi 95, 2.0 i 16V		AK-735091	
Alternator Freewheel Clutch	2.0 HDi 110		F5-1020	
Alternator Freewheel Clutch	1.9 D 70, 2.0 HDi 110, 2.0 HDi 95		F5-1046	
Alternator Freewheel Clutch	2.0 HDi 110		F5-1048	
Anti-Friction Bearing	1.6, 1.6 i, 1.9 D, 1.9 D 70, 1.9 DT, 1.9 TD, 2.0 HDi 110, 2.0 HDi 95, 2.0 i 16V, 2.2 HDi		F8-3014	
Stabiliser Mounting	1.6 i, 1.9 D 70, 1.9 TD, 2.0 HDi 110, 2.0 HDi 95, 2.0 i 16V		F8-5092	
Engine Mounting	1.6 i, 1.9 D 70, 1.9 DT, 1.9 TD, 2.0 i 16V		F8-5569	
Top Strut Mounting	1.6 i, 1.9 D 70, 1.9 TD, 2.0 HDi 110, 2.0 HDi 95, 2.0 i 16V		F8-5621	
Top Strut Mounting	1.6 i, 1.9 D 70, 1.9 TD, 2.0 HDi 110, 2.0 HDi 95, 2.0 i 16V		F8-5622	
Belt Pulley, crankshaft	2.0 HDi 95	Orga.→09519	F8-5636	
Belt Pulley, crankshaft	1.9 D, 1.9 DT, 1.9 TD	Number of Ribs: 6	F8-5643	
Belt Pulley, crankshaft	1.9 D 70	ch.→09894;	F8-5659	
Belt Pulley, crankshaft	1.9 D 70	09/2004 →;  DW8B; Orga.10178→;	F8-5660	
Belt Pulley, crankshaft	2.0 HDi 110	12/2003 →	F8-5660	
Belt Pulley, crankshaft	2.0 HDi 95	Orga.09520→	F8-5660	
Mounting, axle beam	1.6 i, 1.9 D 70, 1.9 TD, 2.0 HDi 110, 2.0 HDi 95, 2.0 i 16V		F8-5871	
Rubber Buffer, suspension	1.6 i, 1.9 D 70, 1.9 TD, 2.0 HDi 110, 2.0 HDi 95, 2.0 i 16V		F8-5936	
Control Arm-/Trailing Arm Bush	1.6 i, 1.9 D 70, 1.9 DT, 1.9 TD, 2.0 HDi 110, 2.0 HDi 95, 2.0 i 16V, 2.2 HDi		F8-6153	
Control Arm-/Trailing Arm Bush	1.6 i, 1.9 D 70, 1.9 DT, 1.9 TD, 2.0 HDi 110, 2.0 HDi 95, 2.0 i 16V, 2.2 HDi		F8-6154	
Control Arm-/Trailing Arm Bush	1.6 i, 1.9 D 70, 1.9 DT, 1.9 TD, 2.0 HDi 110, 2.0 HDi 95, 2.0 i 16V, 2.2 HDi		F8-6155	
Engine Mounting	1.9 D 70, 1.9 DT, 2.0 HDi 110, 2.0 HDi 95, 2.0 i 16V		F8-6236	
Top Strut Mounting	1.6 i, 1.9 D 70, 1.9 DT, 1.9 TD, 2.0 HDi 95, 2.0 i 16V, 2.2 HDi		F8-6304	
Engine Mounting	2.0 HDi 110, 2.0 HDi 95, 2.0 i 16V		F8-6507	
Top Strut Mounting	1.6 i, 1.9 D 70, 1.9 TD, 2.0 HDi 95, 2.0 i 16V		F8-7164	
Belt Pulley, crankshaft	1.9 D 70	Orga.09895→;	F8-7862	
Engine Mounting	2.0 HDi 110, 2.0 HDi 95		F8-8149	
Engine Mounting	1.9 D 70, 2.0 HDi 110, 2.0 HDi 95		F8-8167	
Bellow, steering	1.6, 1.6 i, 1.9 D, 1.9 D 70, 1.9 DT, 1.9 TD, 2.0 HDi 110, 2.0 HDi 95, 2.0 i 16V, 2.2 HDi	with clamps	LM-10022S	

<b>AK-735091</b>	<b>F5-1020</b>	<b>F5-1046</b>	<b>F5-1048</b>	<b>F8-3014</b>	<b>F8-5092</b>	<b>F8-5569</b>
Ref.Nr.: 503339	Ref.Nr.: 31771-68D01	Ref.Nr.: 30667687	Ref.Nr.: 77363468	Ref.Nr.: 503545	Ref.Nr.: 1305782080	Ref.Nr.: 9604338880
<b>F8-5621</b>	<b>F8-5622</b>	<b>F8-5636</b>	<b>F8-5643</b>	<b>F8-5659</b>	<b>F8-5660</b>	<b>F8-5871</b>
Ref.Nr.: 1311931080	Ref.Nr.: 503868	Ref.Nr.: 0515P2	Ref.Nr.: 96089 38980	Ref.Nr.: 0515Q6	Ref.Nr.: 0515R9	Ref.Nr.: 515261
<b>F8-5936</b>	<b>F8-6153</b>	<b>F8-6154</b>	<b>F8-6155</b>	<b>F8-6236</b>	<b>F8-6304</b>	<b>F8-6507</b>
Ref.Nr.: 5033.39	Ref.Nr.: 3520.G9S1	Ref.Nr.: 3521.C9S	Ref.Nr.: 1316735080S	Ref.Nr.: 1809.21	Ref.Nr.: 1311930080	Ref.Nr.: 1827.16

Article Description



Article Nr.

Fitting Position



**DISPATCH Platform/Chassis (BU, BV, BW, BX)**

10/1999 → 10/2006

Dust Cover Kit, shock absorber	1.9 TD, 2.0 HDi 95		AK-735091			
Alternator Freewheel Clutch	2.0 HDi 110 16V		F5-1020			
Alternator Freewheel Clutch	1.9 TD, 2.0 HDi 110 16V, 2.0 HDi 95		F5-1046			
Alternator Freewheel Clutch	2.0 HDi 110		F5-1048			
Anti-Friction Bearing	All Models		F8-3014			H1=24; H2=46; d1=78; d2=84; D=128
Stabiliser Mounting	1.9 TD, 2.0 HDi 95		F8-5092			d=24
Engine Mounting	2.0		F8-5569			
Top Strut Mounting	1.9 TD, 2.0 HDi 95		F8-5621			
Top Strut Mounting	1.9 TD, 2.0 HDi 95		F8-5622			
Belt Pulley, crankshaft	2.0 HDi 95	Orga. →09519	F8-5636			d=30
Belt Pulley, crankshaft	1.9 TD	Number of Ribs: 6	F8-5643			Belt Pulley Ø [mm]=156; W=44
Belt Pulley, crankshaft	2.0 HDi 110 16V		F8-5660			
Belt Pulley, crankshaft	2.0 HDi 95	Orga.09520→	F8-5660			
Mounting, axle beam	1.9 TD, 2.0 HDi 95		F8-5871			H1=60; H2=48; d=12; D=46
Rubber Buffer, suspension	1.9 TD, 2.0 HDi 95		F8-5936			
Control Arm-/Trailing Arm Bush	1.9 TD, 2.0, 2.0 HDi 110 16V, 2.0 HDi 95		F8-6153			
Control Arm-/Trailing Arm Bush	1.9 TD, 2.0, 2.0 HDi 110 16V, 2.0 HDi 95		F8-6154			
Control Arm-/Trailing Arm Bush	1.9 TD, 2.0, 2.0 HDi 110 16V, 2.0 HDi 95		F8-6155			
Engine Mounting	1.9 TD, 2.0, 2.0 HDi 110 16V, 2.0 HDi 95		F8-6236			H1=53; H2=40; d=10; D=70
Top Strut Mounting	1.9 TD, 2.0, 2.0 HDi 110 16V, 2.0 HDi 95		F8-6304			
Engine Mounting	2.0, 2.0 HDi 110 16V, 2.0 HDi 95		F8-6507			
Top Strut Mounting	1.9 TD, 2.0 HDi 95		F8-7164			
Engine Mounting	2.0 HDi 110 16V, 2.0 HDi 95		F8-8149			
Engine Mounting	2.0 HDi 95		F8-8167			
Bellow, steering	1.9 TD, 2.0, 2.0 HDi 110 16V, 2.0 HDi 95	with clamps	LM-10022S			d1=13; d2=62; L [mm]=210

**DISPATCH Box**

01/2007 →

Alternator Freewheel Clutch	1.6 HDi 90, 2.0 HDi 120, 2.0 HDi 140		F5-1046			
Alternator Freewheel Clutch	1.6 HDi 90, 2.0 HDi 120, 2.0 HDi 140		F5-1048			
Anti-Friction Bearing	1.6 HDi 90, 2.0 HDi 120, 2.0 HDi 125, 2.0 HDi 140, 2.0 HDi 165, 2.0 HDi 95, 2.0 i		F8-3014			H1=24; H2=46; d1=78; d2=84; D=128
Engine Mounting	2.0 HDi 120, 2.0 HDi 140		F8-5375			H=34; d=12; D=30
Engine Mounting	1.6 HDi 90, 2.0 i		F8-5569			

<b>AK-735091</b>	<b>F5-1020</b>	<b>F5-1046</b>	<b>F5-1048</b>	<b>F8-3014</b>	<b>F8-5092</b>	<b>F8-5375</b>
Ref.Nr.: 503339	Ref.Nr.: 31771-68D01	Ref.Nr.: 30667687	Ref.Nr.: 77363468	Ref.Nr.: 503545	Ref.Nr.: 1305782080	Ref.Nr.: 180906
<b>F8-5569</b>	<b>F8-5621</b>	<b>F8-5622</b>	<b>F8-5636</b>	<b>F8-5643</b>	<b>F8-5660</b>	<b>F8-5871</b>
Ref.Nr.: 9604338880	Ref.Nr.: 1311931080	Ref.Nr.: 503868	Ref.Nr.: 0515P2	Ref.Nr.: 96089 38980	Ref.Nr.: 0515R9	Ref.Nr.: 515261
<b>F8-5936</b>	<b>F8-6153</b>	<b>F8-6154</b>	<b>F8-6155</b>	<b>F8-6236</b>	<b>F8-6304</b>	<b>F8-6507</b>
Ref.Nr.: 5033.39	Ref.Nr.: 3520.G9S1	Ref.Nr.: 3521.C9S	Ref.Nr.: 1316735080S	Ref.Nr.: 1809.21	Ref.Nr.: 1311930080	Ref.Nr.: 1827.16



**Article Description****Article Nr.****Fitting Position**

<b>DISPATCH Box</b>			<b>01/2007 →</b>		
Control Arm-/Trailing Arm Bush	1.6 HDi 90, 2.0 HDi 120, 2.0 HDi 140, 2.0 i		<b>F8-6153</b>		
Control Arm-/Trailing Arm Bush	1.6 HDi 90, 2.0 HDi 120, 2.0 HDi 140, 2.0 i		<b>F8-6154</b>		
Control Arm-/Trailing Arm Bush	1.6 HDi 90, 2.0 HDi 120, 2.0 HDi 140, 2.0 i		<b>F8-6155</b>		
Engine Mounting	2.0 HDi 120, 2.0 HDi 140, 2.0 i		<b>F8-6236</b>		H1=53; H2=40; d=10; D=70
Engine Mounting	2.0 HDi 120, 2.0 HDi 140		<b>F8-6507</b>		
Belt Pulley, crankshaft	1.6 HDi 90	Number of Ribs: 5; Parameter: 6PK	<b>F8-7645</b>		D=157.75
Engine Mounting	2.0 HDi 120, 2.0 HDi 140		<b>F8-8149</b>		
Engine Mounting	2.0 i		<b>F8-8169</b>		
Engine Mounting	1.6 HDi 90		<b>F8-8184</b>		
<b>LNA</b>			<b>11/1976 → 10/1986</b>		
Dust Cover Kit, shock absorber	0.6	01/1979 →	<b>AK-735010</b>		
Dust Cover Kit, shock absorber	0.6, 1.1		<b>AK-735010</b>		
Engine Mounting	1.0, 1.1		<b>F8-6854</b>		
Control Arm-/Trailing Arm Bush	0.6, 1.1		<b>G9-521</b>		H1=24; H2=42; d=14; D1=21; D2=38
<b>NEMO Box (AA_)</b>			<b>02/2008 →</b>		
Belt Pulley, crankshaft	1.4	Number of Ribs: 5; Parameter: 6PK	<b>F8-6394</b>		H=25; d=44.05; Mounting points diam.[mm]=9; D=148; D1=142.9
Top Strut Mounting	1.3 HDi 75, 1.4, 1.4 HDi		<b>F8-7428</b>		
Top Strut Mounting	1.3 HDi 75, 1.4, 1.4 HDi		<b>F8-7429</b>		
Belt Pulley, crankshaft	1.4 HDi	Number of Ribs: 5; Parameter: 6PK	<b>F8-7645</b>		D=157.75
<b>NEMO Estate</b>			<b>04/2009 →</b>		
Belt Pulley, crankshaft	1.4	Number of Ribs: 5; Parameter: 6PK	<b>F8-6394</b>		H=25; d=44.05; Mounting points diam.[mm]=9; D=148; D1=142.9
Top Strut Mounting	1.3 HDi 75, 1.4, 1.4 HDi		<b>F8-7428</b>		
Top Strut Mounting	1.3 HDi 75, 1.4, 1.4 HDi		<b>F8-7429</b>		
Belt Pulley, crankshaft	1.4 HDi	Number of Ribs: 5; Parameter: 6PK	<b>F8-7645</b>		D=157.75
<b>SAXO (S0, S1)</b>			<b>02/1996 → 04/2004</b>		
Dust Cover Kit, shock absorber	1.0 X, 1.1 X,SX, 1.4 VTS, 1.5 D, 1.6 VTL,VTR, 1.6 VTR, 1.6 VTS		<b>AK-735021</b>		
Anti-Friction Bearing	1.0 X, 1.1 X,SX, 1.4 VTS, 1.5 D, 1.6, 1.6 VTL,VTR, 1.6 VTR, 1.6 VTS, Electric		<b>F8-3012</b>		H=20; d=66; D=100
Anti-Friction Bearing	1.1 X,SX	TU1M	<b>F8-3012</b>		H=20; d=66; D=100
Control Arm-/Trailing Arm Bush	1.1 X,SX, 1.4 VTS, 1.6 VTL,VTR, 1.6 VTS		<b>F8-5251</b>		

<b>AK-735010</b>	<b>AK-735021</b>	<b>F8-3012</b>	<b>F8-5251</b>	<b>F8-5356</b>	<b>F8-6153</b>	<b>F8-6154</b>
Ref.Nr.:	Ref.Nr.:	Ref.Nr.: 503527	Ref.Nr.: 352364	Ref.Nr.: 328769	Ref.Nr.: 3520.G9S1	Ref.Nr.: 3521.C9S
<b>F8-6155</b>	<b>F8-6236</b>	<b>F8-6394</b>	<b>F8-6507</b>	<b>F8-6854</b>	<b>F8-7428</b>	<b>F8-7429</b>
Ref.Nr.: 1316735080S	Ref.Nr.: 1809.21	Ref.Nr.: 0515.R8	Ref.Nr.: 1827.16	Ref.Nr.: 1807.45	Ref.Nr.: 5038J8	Ref.Nr.: 5038G8
<b>F8-7645</b>	<b>F8-8149</b>	<b>F8-8169</b>	<b>F8-8184</b>	<b>G9-521</b>		
Ref.Nr.: 0515.T3	Ref.Nr.: 1844.93	Ref.Nr.: 180669	Ref.Nr.: 1806.33	Ref.Nr.: 91504248		

Article Description



Article Nr.

Fitting Position



SAXO (S0, S1)		02/1996 → 04/2004	
Bellow, driveshaft	1.6 VTL,VTR, 1.6 VTS	<b>F8-5356</b>	⊕ ⊕ ⊕ D1=72; D219; L=172
Top Strut Mounting	1.0 X, 1.1 X,SX, 1.4 VTS, 1.5 D, 1.6 VTL,VTR, 1.6 VTS	<b>F8-5518</b>	⊕ ⊕ ⊕
Engine Mounting	1.0 X, 1.1 X,SX, 1.4 VTS, 1.6 VTL,VTR, 1.6 VTS	<b>F8-5556</b>	⊕
Belt Pulley, crankshaft	1.5 D	<b>F8-5644</b>	
Mounting, axle beam	1.0 X, 1.1 X,SX, 1.4 VTS, 1.5 D, 1.6, 1.6 VTL,VTR, 1.6 VTR, 1.6 VTS, Electric	<b>F8-5799</b>	⊕ ⊕ ⊕ H=47; d=12; D=32
Stabiliser Mounting	1.0 X, 1.1 X,SX, 1.4 VTS, 1.5 D, 1.6, 1.6 VTL,VTR, 1.6 VTR, 1.6 VTS, Electric	Orga.O 04803→; Stabi. Diam. [mm]= 19 <b>F8-6096</b>	d=19
Control Arm-/Trailing Arm Bush	1.1 X,SX, 1.4 VTS, 1.6, 1.6 VTL,VTR, 1.6 VTR, 1.6 VTS	<b>F8-6143</b>	⊕ ⊕ ⊕
Repair Kit, wheel suspension	1.0 X, 1.1 X,SX, 1.4 VTS, 1.5 D, 1.6, 1.6 VTL,VTR, 1.6 VTR, 1.6 VTS, Electric	 <b>F8-6274</b>	
Repair Kit, wheel suspension	1.0 X, 1.1 X,SX, 1.4 VTS, 1.5 D, 1.6, 1.6 VTL,VTR, 1.6 VTR, 1.6 VTS, Electric	 <b>F8-6275</b>	
Top Strut Mounting	1.0 X, 1.1 X,SX, 1.4 VTS, 1.5 D, 1.6 VTL,VTR, 1.6 VTS	 <b>F8-6293</b>	
Mounting, automatic transmission	1.4 VTS, 1.6 VTL,VTR	 <b>F8-6505</b>	⊕
Mounting, automatic transmission	1.5 D, 1.6, 1.6 VTS	<b>F8-6505</b>	⊕
Engine Mounting	1.4 VTS	<b>F8-6898</b>	⊕
Engine Mounting	1.0 X, 1.1 X,SX, 1.5 D, 1.6 VTS	<b>F8-6904</b>	
Engine Mounting	1.4 VTS, 1.6 VTL,VTR	 <b>F8-6904</b>	
Belt Pulley, crankshaft	1.6, 1.6 VTS	Number of Ribs: 4; Parameter: 5PK;	<b>F8-7643</b> D=128
Engine Mounting	1.0 X, 1.1 X,SX	<b>F8-8199</b>	⊕
Repair Kit, wheel suspension	1.0 X, 1.1 X,SX, 1.4 VTS, 1.5 D, 1.6, 1.6 VTL,VTR, 1.6 VTR, 1.6 VTS, Electric	 <b>G8-274</b>	
Repair Kit, wheel suspension	1.0 X, 1.1 X,SX, 1.4 VTS, 1.5 D, 1.6, 1.6 VTL,VTR, 1.6 VTR, 1.6 VTS, Electric	 <b>G8-275</b>	
Control Arm-/Trailing Arm Bush	1.0 X, 1.1 X,SX, 1.4 VTS, 1.5 D, 1.6 VTL,VTR	<b>G9-555</b>	⊕ ⊕ ⊕ H=46; d=17; W=55, 85
Control Arm-/Trailing Arm Bush	1.6 VTS	for OE: 352078 <b>G9-555</b>	⊕ ⊕ ⊕ H=46; d=17; W=55, 85
Control Arm-/Trailing Arm Bush	1.0 X, 1.1 X,SX, 1.4 VTS, 1.5 D, 1.6 VTL,VTR	<b>G9-556</b>	⊕ ⊕ ⊕ ⊕ H1=30; H2=49; d=12; D=34
Control Arm-/Trailing Arm Bush	1.0 X, 1.6 VTS	for OE: 352078 <b>G9-556</b>	⊕ ⊕ ⊕ ⊕ H1=30; H2=49; d=12; D=34
Bellow, steering	1.0 X, 1.1 X,SX, 1.4 VTS, 1.5 D, 1.6, 1.6 VTL,VTR, 1.6 VTR, 1.6 VTS, Electric	<b>LM-10014S</b>	d1=12; d2=40; L [mm]=106
Bellow, steering	1.0 X	; Orga.07084, 07119→; with clamps;	<b>LM-10047S</b> d1=22; d2=45; L [mm]=120

<b>F8-5356</b>	<b>F8-5518</b>	<b>F8-5556</b>	<b>F8-5644</b>	<b>F8-5799</b>	<b>F8-6096</b>	<b>F8-6143</b>
Ref.Nr.: 328769	Ref.Nr.: 503815	Ref.Nr.: 1843.95	Ref.Nr.: 0515L6	Ref.Nr.: 5131.63	Ref.Nr.: 5094.59	Ref.Nr.: 96148480
<b>F8-6274</b>	<b>F8-6275</b>	<b>F8-6293</b>	<b>F8-6505</b>	<b>F8-6898</b>	<b>F8-6904</b>	<b>F8-7643</b>
Ref.Nr.: 5133.22	Ref.Nr.: 5174.07	Ref.Nr.: 503527	Ref.Nr.: 1844.51	Ref.Nr.: 1844.58	Ref.Nr.: 1844.54	Ref.Nr.: 0515.J3
<b>F8-8199</b>	<b>G8-274</b>	<b>G8-275</b>	<b>G9-555</b>	<b>G9-556</b>	<b>LM-10014S</b>	<b>LM-10047S</b>
Ref.Nr.: 184399	Ref.Nr.: 514858	Ref.Nr.: 5174.05	Ref.Nr.: 3523.51	Ref.Nr.: 95603308	Ref.Nr.: 4066.32	Ref.Nr.: 4066.50

**Article Description****Article Nr.****Fitting Position**

<b>SAXO (S0, S1)</b>				<b>02/1996 → 04/2004</b>	
Bellow, steering	1.0 X, 1.1 X,SX	; Orga.07084, 07119→; with clamps;	<b>LM-10047S</b>		d1=22; d2=45; L [mm]=120
Bellow, steering	1.0 X, 1.1 X,SX, 1.4 VTS, 1.5 D, 1.6, 1.6 VTL,VTR, 1.6 VTR, 1.6 VTS, Electric	; Orga.07084→; with clamps;	<b>LM-10047S</b>		d1=22; d2=45; L [mm]=120
Bellow, steering	1.0 X, 1.1 X,SX, 1.4 VTS, 1.5 D, 1.6, 1.6 VTL,VTR, 1.6 VTR, 1.6 VTS, Electric	; Orga.07084→; with clamps	<b>LM-10047S</b>		d1=22; d2=45; L [mm]=120
Bellow, steering	1.0 X, 1.1 X,SX, 1.4 VTS, 1.5 D, 1.6, 1.6 VTL,VTR, 1.6 VTR, 1.6 VTS	with adapter, with clamps	<b>LM-10051S</b>		H=20; d=38; d1=17; d2=22; L [mm]=134
<b>VISA</b>				<b>09/1978 → 03/1991</b>	
Dust Cover Kit, shock absorber	0.6, 1.0, 11 E, 14, 14 GT, 16 GTI, 17 D, II Super X		<b>AK-735010</b>		
Anti-Friction Bearing	14, 14 GT, 16 GTI, 17 D		<b>F8-3012</b>		H=20; d=66; D=100
Control Arm-/Trailing Arm Bush	16 GTI		<b>F8-5072</b>		d=12; D=42; W=38
Control Arm-/Trailing Arm Bush	0.6, 1.0, 11 E, 14, 14 GT, 16 GTI, 17 D, II Super X		<b>F8-5078</b>		d=12; D=36; Thick. [mm]=25
Bellow, driveshaft	16 GTI	Transmission Type: BE1, BE3	<b>F8-5356</b>		D1=72; D219; L=172
Top Strut Mounting	14, 14 GT, 16 GTI, 17 D		<b>F8-5520</b>		
Stabiliser Mounting	17 D	Stabi. Diam. [mm]= 22	<b>F8-6794</b>		d=22
Stabiliser Mounting	17 D		<b>F8-6795</b>		D=23; d=22
Engine Mounting	1.0, 11 E, 14, 14 GT, II Super X	for OE: 180745	<b>F8-6854</b>		
Control Arm-/Trailing Arm Bush	0.6, 1.0, 11 E, 14, 14 GT, 17 D, II Super X		<b>G9-520</b>		H1=34; H2=28; d=10; D=28
Control Arm-/Trailing Arm Bush	0.6, 1.0, 11 E, 14, 14 GT, 17 D, II Super X		<b>G9-521</b>		H1=24; H2=42; d=14; D1=21; D2=38
Control Arm-/Trailing Arm Bush	17 D		<b>G9-523</b>		H=25; d=12; D1=36; D2=47
Repair Kit, link	17 D		<b>G9-523S</b>		H=25; d=12; D1=36; D2=47
Control Arm-/Trailing Arm Bush	16 GTI		<b>G9-525</b>		H=34; d=10; D=28
<b>VISA Convertible</b>				<b>03/1983 → 10/1988</b>	
Dust Cover Kit, shock absorber	All Models		<b>AK-735010</b>		
Engine Mounting	All Models	for OE: 180745	<b>F8-6854</b>		
Control Arm-/Trailing Arm Bush	All Models		<b>G9-520</b>		H1=34; H2=28; d=10; D=28
Control Arm-/Trailing Arm Bush	All Models		<b>G9-521</b>		H1=24; H2=42; d=14; D1=21; D2=38
Control Arm-/Trailing Arm Bush	All Models		<b>G9-523</b>		H=25; d=12; D1=36; D2=47
Repair Kit, link	All Models		<b>G9-523S</b>		H=25; d=12; D1=36; D2=47

<b>AK-735010</b>	<b>F8-3012</b>	<b>F8-5026</b>	<b>F8-5072</b>	<b>F8-5078</b>	<b>F8-5356</b>	<b>F8-5520</b>
Ref.Nr.:	Ref.Nr.: 503527	Ref.Nr.: 9606121080	Ref.Nr.: 3523.23	Ref.Nr.: 2523.29	Ref.Nr.: 328769	Ref.Nr.: 503518
<b>F8-6794</b>	<b>F8-6795</b>	<b>F8-6854</b>	<b>G9-520</b>	<b>G9-521</b>	<b>G9-523</b>	<b>G9-523S</b>
Ref.Nr.: 5094.37	Ref.Nr.: 5094.40	Ref.Nr.: 1807.45	Ref.Nr.: 96096727	Ref.Nr.: 91504248	Ref.Nr.: 3523.25	Ref.Nr.: 3523.25
<b>G9-525</b>	<b>LM-10047S</b>	<b>LM-10051S</b>				
Ref.Nr.: 3523.31	Ref.Nr.: 4066.50	Ref.Nr.: 4066.34				

**Article Description**

**Article Nr.**
**Fitting Position**

<b>XANTIA (X1)</b>			<b>03/1993 → 01/1998</b>		
Engine Mounting	1.6 i, 1.8 i, 1.8 i 16V, 1.9 D, 1.9 SD, 1.9 Turbo D, 2.0 i, 2.0 i 16V, 2.0 Turbo, 2.1 Turbo D 12V		<b>F8-5026</b>		d=10; D=70; Thick. [mm]=40, 53
Control Arm-/Trailing Arm Bush	1.6 i, 1.8 i, 1.8 i 16V, 1.9 D, 1.9 SD, 1.9 Turbo D, 2.0 i, 2.0 i 16V, 2.0 Turbo, 2.1 Turbo D 12V, 3.0 i 24V		<b>F8-5271</b>		
Engine Mounting	1.6 i, 1.8 i, 1.8 i 16V, 1.9 SD, 1.9 Turbo D, 2.0 i, 2.0 i 16V		<b>F8-5357</b>		
Engine Mounting	1.6 i, 1.8 i, 1.8 i 16V, 1.9 D		<b>F8-5556</b>		
Engine Mounting	1.6 i		<b>F8-5568</b>		
Engine Mounting	1.8 i, 1.8 i 16V, 1.9 D		<b>F8-5568</b>		
Engine Mounting	1.9 SD, 1.9 Turbo D, 2.0, 2.0 i, 2.0 i 16V		<b>F8-5569</b>		
Belt Pulley, crankshaft	1.9 D, 1.9 SD, 1.9 Turbo D	Number of Ribs: 6	<b>F8-5643</b>		Belt Pulley Ø [mm]=156; W=44
Belt Pulley, crankshaft	2.1 Turbo D 12V		<b>F8-5647</b>		
Control Arm-/Trailing Arm Bush	All Models		<b>F8-6171</b>		
Control Arm-/Trailing Arm Bush	All Models		<b>F8-6172</b>		
Engine Mounting	1.8 i 16V, 1.9 SD, 1.9 Turbo D, 2.0 Turbo		<b>F8-6236</b>		H1=53; H2=40; d=10; D=70
Engine Mounting	1.8 i, 1.8 i 16V, 1.9 D, 1.9 SD, 1.9 Turbo D		<b>F8-6237</b>		
Engine Mounting	1.9 D		<b>F8-6500</b>		
Engine Mounting	1.8 i, 2.0 i		<b>F8-6507</b>		
Engine Mounting	2.0, 2.0 Turbo, 2.1 Turbo D 12V		<b>F8-6507</b>		
Engine Mounting	2.0 Turbo		<b>F8-6538</b>		
Engine Mounting	2.0 Turbo		<b>F8-6857</b>		
Belt Pulley, crankshaft	1.8 i 16V, 2.0 i 16V	07/1995 →; Number of Ribs: 6	<b>F8-7083</b>		Belt Pulley Ø [mm]=127; Mounting points diam.[mm]=30; W=38
Belt Pulley, crankshaft	1.8 i, 2.0 i	Number of Ribs: 6	<b>F8-7084</b>		Belt Pulley Ø [mm]=127; Mounting points diam.[mm]=30; W=45
Belt Pulley, crankshaft	2.0 Turbo	07/1995 →; Number of Ribs: 6	<b>F8-7084</b>		Belt Pulley Ø [mm]=127; Mounting points diam.[mm]=30; W=45
Belt Pulley, crankshaft	3.0 i 24V		<b>F8-7874</b>		
Stabiliser Mounting	1.6 i, 1.8 i, 1.8 i 16V, 1.9 D, 1.9 Turbo D, 2.0 i 16V, 2.0 Turbo, 2.1 Turbo D 12V		<b>F8-7980</b>		
Repair Set, axle beam	1.6 i, 1.8 i, 1.8 i 16V, 1.9 D, 1.9 SD, 1.9 Turbo D, 2.0 i, 2.0 i 16V, 2.0 Turbo, 2.1 Turbo D 12V		<b>G8-540</b>		
<b>XANTIA Estate (X1)</b>			<b>06/1995 → 01/1998</b>		
Engine Mounting	All Models		<b>F8-5026</b>		d=10; D=70; Thick. [mm]=40, 53
Control Arm-/Trailing Arm Bush	All Models		<b>F8-5271</b>		

<b>F8-5026</b>	<b>F8-5271</b>	<b>F8-5357</b>	<b>F8-5556</b>	<b>F8-5568</b>	<b>F8-5569</b>	<b>F8-5643</b>
Ref.Nr.: 9606121080	Ref.Nr.: 96083570	Ref.Nr.: 1844.47	Ref.Nr.: 1843.95	Ref.Nr.: 184425	Ref.Nr.: 9604338880	Ref.Nr.: 96089 38980
<b>F8-5647</b>	<b>F8-6171</b>	<b>F8-6172</b>	<b>F8-6236</b>	<b>F8-6237</b>	<b>F8-6500</b>	<b>F8-6507</b>
Ref.Nr.: 0515J9	Ref.Nr.: 352381	Ref.Nr.: 352382	Ref.Nr.: 1809.21	Ref.Nr.: 1809.22	Ref.Nr.: 1844.36	Ref.Nr.: 1827.16
<b>F8-6538</b>	<b>F8-6857</b>	<b>F8-7083</b>	<b>F8-7084</b>	<b>F8-7874</b>	<b>F8-7980</b>	<b>G8-540</b>
Ref.Nr.: 1839.46	Ref.Nr.: 1827.22	Ref.Nr.: 0515.K6	Ref.Nr.: 0515.H6	Ref.Nr.: 0515.S2	Ref.Nr.: 96 089 104	Ref.Nr.: 95619159

**Article Description****Article Nr.****Fitting Position****XANTIA Estate (X1)****06/1995 → 01/1998**

Engine Mounting	1.8 i, 1.8 i 16V, 1.9 SD, 1.9 Turbo D, 2.0 i, 2.0 i 16V		<b>F8-5357</b>			
Engine Mounting	1.8 i, 1.8 i 16V		<b>F8-5556</b>			
Engine Mounting	1.8 i, 1.8 i 16V		<b>F8-5568</b>			
Engine Mounting	1.9 SD, 1.9 Turbo D, 2.0 i, 2.0 i 16V		<b>F8-5569</b>			
Belt Pulley, crankshaft	1.9 SD, 1.9 Turbo D	Number of Ribs: 6	<b>F8-5643</b>			Belt Pulley Ø [mm]=156; W=44
Belt Pulley, crankshaft	2.1 Turbo D 12V		<b>F8-5647</b>			
Control Arm-/Trailing Arm Bush	All Models		<b>F8-6171</b>			
Control Arm-/Trailing Arm Bush	All Models		<b>F8-6172</b>			
Engine Mounting	1.8 i 16V, 1.9 SD, 2.0 Turbo		<b>F8-6236</b>			H1=53; H2=40; d=10; D=70
Engine Mounting	1.8 i, 1.8 i 16V, 1.9 SD		<b>F8-6237</b>			
Engine Mounting	1.8 i, 2.0 i		<b>F8-6507</b>			
Engine Mounting	2.0 Turbo, 2.1 Turbo D 12V		<b>F8-6507</b>			
Engine Mounting	2.0 Turbo		<b>F8-6538</b>			
Engine Mounting	2.0 Turbo		<b>F8-6857</b>			
Belt Pulley, crankshaft	1.8 i 16V, 2.0 i 16V	07/1996 →; Number of Ribs: 6	<b>F8-7083</b>			Belt Pulley Ø [mm]=127; Mounting points diam.[mm]=30; W=38
Belt Pulley, crankshaft	1.8 i	Number of Ribs: 6	<b>F8-7084</b>			Belt Pulley Ø [mm]=127; Mounting points diam.[mm]=30; W=45
Belt Pulley, crankshaft	2.0 i, 2.0 Turbo	07/1995 →; Number of Ribs: 6	<b>F8-7084</b>			Belt Pulley Ø [mm]=127; Mounting points diam.[mm]=30; W=45
Stabiliser Mounting	1.8 i, 1.8 i 16V, 1.9 Turbo D, 2.0 i 16V, 2.0 Turbo, 2.1 Turbo D 12V		<b>F8-7980</b>			
Repair Set, axle beam	1.8 i, 1.9 Turbo D, 2.0 i, 2.0 i 16V, 2.0 Turbo, 2.1 Turbo D 12V		<b>G8-540</b>			

**XANTIA (X2)****01/1998 → 04/2003**

Alternator Freewheel Clutch	2.0 HDI 109, 2.0 HDI 90		<b>F5-1020</b>			
Engine Mounting	1.8 i, 1.8 i 16V, 1.9 SD, 1.9 Turbo D, 2.0 i, 2.0 i 16V, 2.0 Turbo, 2.1 Turbo D 12V, 3.0 V6		<b>F8-5026</b>			d=10; D=70; Thick. [mm]=40, 53
Control Arm-/Trailing Arm Bush	1.8 i, 1.8 i 16V, 1.9 SD, 1.9 Turbo D, 2.0 HDI 109, 2.0 HDI 90, 2.0 i, 2.0 i 16V, 2.0 Turbo, 2.1 Turbo D 12V, 3.0 V6		<b>F8-5271</b>			
Engine Mounting	1.8 i, 1.8 i 16V, 1.9 SD, 1.9 Turbo D, 2.0 i, 2.0 i 16V		<b>F8-5357</b>			
Engine Mounting	1.8 i, 1.8 i 16V		<b>F8-5556</b>			
Engine Mounting	1.8 i, 1.8 i 16V, 2.0 HDI 90		<b>F8-5568</b>			
Engine Mounting	1.9 SD, 1.9 Turbo D, 2.0 i 16V		<b>F8-5569</b>			

<b>F5-1020</b>	<b>F8-5026</b>	<b>F8-5271</b>	<b>F8-5357</b>	<b>F8-5556</b>	<b>F8-5568</b>	<b>F8-5569</b>
Ref.Nr.: 31771-68D01	Ref.Nr.: 9606121080	Ref.Nr.: 96083570	Ref.Nr.: 1844.47	Ref.Nr.: 1843.95	Ref.Nr.: 184425	Ref.Nr.: 9604338880
<b>F8-5636</b>	<b>F8-5643</b>	<b>F8-5647</b>	<b>F8-6171</b>	<b>F8-6172</b>	<b>F8-6236</b>	<b>F8-6237</b>
Ref.Nr.: 0515P2	Ref.Nr.: 96089 38980	Ref.Nr.: 0515J9	Ref.Nr.: 352381	Ref.Nr.: 352382	Ref.Nr.: 1809.21	Ref.Nr.: 1809.22
<b>F8-6507</b>	<b>F8-6538</b>	<b>F8-6857</b>	<b>F8-7083</b>	<b>F8-7084</b>	<b>F8-7980</b>	<b>G8-540</b>
Ref.Nr.: 1827.16	Ref.Nr.: 1839.46	Ref.Nr.: 1827.22	Ref.Nr.: 0515.K6	Ref.Nr.: 0515.H6	Ref.Nr.: 96 089 104	Ref.Nr.: 95619159

Article Description



Article Nr.

Fitting Position



## XANTIA (X2)

01/1998 → 04/2003

Belt Pulley, crankshaft	2.0 HDI 109, 2.0 HDI 90		<b>F8-5636</b>		d=30
Belt Pulley, crankshaft	1.9 SD, 1.9 Turbo D	Number of Ribs: 6	<b>F8-5643</b>		Belt Pulley Ø [mm]=156; W=44
Belt Pulley, crankshaft	2.1 Turbo D 12V		<b>F8-5647</b>		
Control Arm-/Trailing Arm Bush	1.8 i, 1.8 i 16V, 1.9 SD, 1.9 Turbo D, 2.0 HDI 109, 2.0 HDI 90, 2.0 i, 2.0 i 16V, 2.0 Turbo, 2.1 Turbo D 12V, 3.0 V6		<b>F8-6171</b>		
Control Arm-/Trailing Arm Bush	1.8 i, 1.8 i 16V, 1.9 SD, 1.9 Turbo D, 2.0 HDI 109, 2.0 HDI 90, 2.0 i, 2.0 i 16V, 2.0 Turbo, 2.1 Turbo D 12V, 3.0 V6		<b>F8-6172</b>		
Engine Mounting	1.8 i, 1.8 i 16V, 1.9 SD, 1.9 Turbo D, 2.0 HDI 109, 2.0 HDI 90, 2.0 Turbo		<b>F8-6236</b>		H1=53; H2=40; d=10; D=70
Engine Mounting	1.8 i, 1.8 i 16V, 1.9 SD, 1.9 Turbo D, 2.0 HDI 90		<b>F8-6237</b>		
Engine Mounting	1.9 Turbo D	XUD9TE	<b>F8-6500</b>		
Engine Mounting	1.8 i 16V, 1.9 Turbo D, 2.0 i 16V		<b>F8-6507</b>		
Engine Mounting	2.0 HDI 109, 2.0 HDI 90, 2.0 i, 2.0 Turbo, 2.1 Turbo D 12V		<b>F8-6507</b>		
Engine Mounting	2.0 HDI 109, 2.0 Turbo		<b>F8-6538</b>		
Engine Mounting	2.0 Turbo		<b>F8-6857</b>		
Belt Pulley, crankshaft	1.8 i 16V, 2.0 i 16V	Number of Ribs: 6	<b>F8-7083</b>		Belt Pulley Ø [mm]=127; Mounting points diam.[mm]=30; W=38
Belt Pulley, crankshaft	2.0 i, 2.0 Turbo	Number of Ribs: 6	<b>F8-7084</b>		Belt Pulley Ø [mm]=127; Mounting points diam.[mm]=30; W=45
Belt Pulley, crankshaft	3.0 V6		<b>F8-7874</b>		
Stabiliser Mounting	1.8 i, 1.8 i 16V, 1.9 Turbo D, 2.0 i 16V, 2.0 Turbo, 2.1 Turbo D 12V		<b>F8-7980</b>		

## XANTIA Estate (X2)

01/1998 → 04/2003

Alternator Freewheel Clutch	2.0 HDI 109		<b>F5-1020</b>		
Engine Mounting	1.8 i, 1.8 i 16V, 1.9 SD, 1.9 Turbo D, 2.0 i, 2.0 i 16V, 2.0 Turbo, 2.1 Turbo D 12V		<b>F8-5026</b>		d=10; D=70; Thick. [mm]=40, 53
Control Arm-/Trailing Arm Bush	All Models		<b>F8-5271</b>		
Engine Mounting	1.8 i, 1.8 i 16V, 1.9 SD, 1.9 Turbo D, 2.0 i, 2.0 i 16V		<b>F8-5357</b>		
Engine Mounting	1.8 i, 1.8 i 16V		<b>F8-5556</b>		
Engine Mounting	1.8 i, 1.8 i 16V, 2.0 HDI 90		<b>F8-5568</b>		
Engine Mounting	1.9 SD, 1.9 Turbo D, 2.0 i 16V		<b>F8-5569</b>		
Belt Pulley, crankshaft	2.0 HDI 109, 2.0 HDI 90		<b>F8-5636</b>		d=30
Belt Pulley, crankshaft	1.9 SD, 1.9 Turbo D	Number of Ribs: 6	<b>F8-5643</b>		Belt Pulley Ø [mm]=156; W=44
Belt Pulley, crankshaft	2.1 Turbo D 12V		<b>F8-5647</b>		

<b>F5-1020</b>	<b>F8-5026</b>	<b>F8-5271</b>	<b>F8-5357</b>	<b>F8-5556</b>	<b>F8-5568</b>	<b>F8-5569</b>
Ref.Nr.: 31771-68D01	Ref.Nr.: 9606121080	Ref.Nr.: 96083570	Ref.Nr.: 1844.47	Ref.Nr.: 1843.95	Ref.Nr.: 184425	Ref.Nr.: 9604338880
<b>F8-5636</b>	<b>F8-5643</b>	<b>F8-5647</b>	<b>F8-6171</b>	<b>F8-6172</b>	<b>F8-6236</b>	<b>F8-6237</b>
Ref.Nr.: 0515P2	Ref.Nr.: 96089 38980	Ref.Nr.: 0515J9	Ref.Nr.: 352381	Ref.Nr.: 352382	Ref.Nr.: 1809.21	Ref.Nr.: 1809.22
<b>F8-6500</b>	<b>F8-6507</b>	<b>F8-6538</b>	<b>F8-6857</b>	<b>F8-7083</b>	<b>F8-7084</b>	<b>F8-7874</b>
Ref.Nr.: 1844.36	Ref.Nr.: 1827.16	Ref.Nr.: 1839.46	Ref.Nr.: 1827.22	Ref.Nr.: 0515.K6	Ref.Nr.: 0515.H6	Ref.Nr.: 0515.S2

**Article Description****Article Nr.****Fitting Position**

<b>XANTIA Estate (X2)</b>		<b>01/1998 → 04/2003</b>	
Control Arm-/Trailing Arm Bush	All Models	<b>F8-6171</b>	
Control Arm-/Trailing Arm Bush	All Models	<b>F8-6172</b>	
Engine Mounting	1.8 i, 1.8 i 16V, 1.9 SD, 2.0 HDI 109, 2.0 HDI 90, 2.0 Turbo	<b>F8-6236</b>	H1=53; H2=40; d=10; D=70
Engine Mounting	1.8 i, 1.8 i 16V, 1.9 SD, 2.0 HDI 90	<b>F8-6237</b>	
Engine Mounting	1.8 i 16V, 1.9 Turbo D, 2.0 i 16V	<b>F8-6507</b>	
Engine Mounting	2.0 HDI 109, 2.0 HDI 90, 2.0 i, 2.0 Turbo, 2.1 Turbo D 12V	<b>F8-6507</b>	
Engine Mounting	2.0 HDI 109, 2.0 Turbo	<b>F8-6538</b>	
Engine Mounting	2.0 Turbo	<b>F8-6857</b>	
Belt Pulley, crankshaft	1.8 i 16V, 2.0 i 16V	<b>F8-7083</b>	Number of Ribs: 6 Belt Pulley Ø [mm]=127; Mounting points diam.[mm]=30; W=38
Belt Pulley, crankshaft	2.0 i, 2.0 Turbo	<b>F8-7084</b>	Number of Ribs: 6 Belt Pulley Ø [mm]=127; Mounting points diam.[mm]=30; W=45
Belt Pulley, crankshaft	3.0 V6	<b>F8-7874</b>	
Stabiliser Mounting	1.8 i, 1.8 i 16V, 1.9 Turbo D, 2.0 i 16V, 2.0 Turbo, 2.1 Turbo D 12V	<b>F8-7980</b>	
<b>XM (Y3)</b>		<b>05/1989 → 06/1994</b>	
Control Arm-/Trailing Arm Bush	2.0 i, 2.0 i Turbo, 2.1 D 12V, 2.1 TD 12V, 3.0 V6, 3.0 V6 24V	<b>F8-5150</b>	H=28; d=14; D=40
Engine Mounting	2.0 i, 2.0 i Turbo, 2.1 D 12V	<b>F8-5569</b>	
Engine Mounting	2.0 i, 2.0 i Turbo, 2.1 D 12V	<b>F8-6236</b>	H1=53; H2=40; d=10; D=70
Repair Kit, wheel suspension	2.0, 2.0 i, 2.0 i Turbo, 2.1 D 12V, 2.1 TD 12V, 3.0 V6, 3.0 V6 24V	<b>F8-6271</b>	
Engine Mounting	2.0 i, 2.0 i Turbo, 3.0 V6	<b>F8-6507</b>	
Engine Mounting	2.0, 2.1 D 12V, 2.1 TD 12V, 3.0	<b>F8-6507</b>	
Engine Mounting	3.0 V6 24V	<b>F8-6507</b>	UKZ (ZPJ4/Z);
Engine Mounting	2.0 i, 2.0 i Turbo	<b>F8-6857</b>	
Bellow, steering	2.0, 2.0 i, 2.0 i Turbo, 2.1 D 12V, 2.1 TD 12V, 3.0, 3.0 V6, 3.0 V6 24V	<b>LM-10072S</b>	with clamps;  d1=44; d2=44; L [mm]=120
<b>XM Estate (Y3)</b>		<b>05/1989 → 07/1994</b>	
Control Arm-/Trailing Arm Bush	2.0 i, 2.0 Turbo, 2.1 D 12V, 2.1 TD 12V	<b>F8-5150</b>	H=28; d=14; D=40
Engine Mounting	2.0 i, 2.0 Turbo, 2.1 D 12V	<b>F8-5569</b>	
Engine Mounting	2.0 i, 2.0 Turbo, 2.1 D 12V	<b>F8-6236</b>	H1=53; H2=40; d=10; D=70
Engine Mounting	2.0 i, 2.0 Turbo, 3.0 V6	<b>F8-6507</b>	

<b>F8-5150</b>	<b>F8-5569</b>	<b>F8-6171</b>	<b>F8-6172</b>	<b>F8-6236</b>	<b>F8-6237</b>	<b>F8-6271</b>
Ref.Nr.: 3523.43	Ref.Nr.: 9604338880	Ref.Nr.: 352381	Ref.Nr.: 352382	Ref.Nr.: 1809.21	Ref.Nr.: 1809.22	Ref.Nr.:
<b>F8-6507</b>	<b>F8-6538</b>	<b>F8-6857</b>	<b>F8-7083</b>	<b>F8-7084</b>	<b>F8-7874</b>	<b>F8-7980</b>
Ref.Nr.: 1827.16	Ref.Nr.: 1839.46	Ref.Nr.: 1827.22	Ref.Nr.: 0515.K6	Ref.Nr.: 0515.H6	Ref.Nr.: 0515.S2	Ref.Nr.: 96 089 104
<b>LM-10072S</b>						
Ref.Nr.: 4066.30						

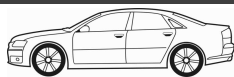
**Article Description**

**Article Nr.**
**Fitting Position**

<b>XM Estate (Y3)</b>			<b>05/1989 → 07/1994</b>		
Engine Mounting	2.0, 2.1 D 12V, 2.1 TD 12V, 3.0, 3.0 Pallas		<b>F8-6507</b>		
Engine Mounting	2.0 i, 2.0 Turbo		<b>F8-6857</b>		
Stabiliser Mounting	2.1 TD 12V		<b>F8-7980</b>		
Bellow, steering	2.0 i , 2.0 Turbo, 2.1 D 12V, 2.1 TD 12V, 3.0 V6	with clamps;	<b>LM-10072S</b>		d1=44; d2=44; L [mm]=120
<b>XM (Y4)</b>			<b>05/1994 → 10/2000</b>		
Control Arm-/Trailing Arm Bush	2.0 i 16V, 2.0 Turbo, 2.1 TD 12V, 2.5 TD, 3.0 V6, 3.0 V6 24V		<b>F8-5150</b>		H=28; d=14; D=40
Engine Mounting	2.0 i 16V, 2.0 Turbo, 2.1 D12 VSX		<b>F8-5569</b>		
Belt Pulley, crankshaft	2.1 TD 12V	XUD11ATE, XUD11BTE; Orga.06779→; Orga.→07237;	<b>F8-5647</b>		
Engine Mounting	2.0 i 16V, 2.0 Turbo, 2.1 D12 VSX, 2.1 TD 12V		<b>F8-6236</b>		H1=53; H2=40; d=10; D=70
Repair Kit, wheel suspension	2.0 i 16V, 2.0 Turbo, 2.1 TD 12V, 2.5 TD, 3.0 V6, 3.0 V6 24V		<b>F8-6271</b>		
Belt Pulley, crankshaft	2.5 TD		<b>F8-6395</b>		
Engine Mounting	2.0 i 16V, 2.0 Turbo, 3.0 V6		<b>F8-6507</b>		
Engine Mounting	2.1 TD 12V	XUD11ATE; Orga.→07237;	<b>F8-6507</b>		
Engine Mounting	3.0 V6	UFZ (ZPJ/Z);	<b>F8-6507</b>		
Engine Mounting	3.0 V6 24V	UKZ (ZPJ4/Z);	<b>F8-6507</b>		
Engine Mounting	2.0 i 16V	07/1994 →;	<b>F8-6857</b>		
Engine Mounting	2.0 Turbo	ch.O06748 →; 07/1994 →;	<b>F8-6857</b>		
Holder, engine mounting	3.0 V6		<b>F8-7011</b>		d=10; L=53; D=69
Belt Pulley, crankshaft	2.0 i 16V	07/1994 →; Number of Ribs: 6	<b>F8-7083</b>		Belt Pulley Ø [mm]=127; Mounting points diam.[mm]=30; W=38
Belt Pulley, crankshaft	3.0 V6		<b>F8-7874</b>		
Bellow, steering	All Models	with clamps;	<b>LM-10072S</b>		d1=44; d2=44; L [mm]=120
<b>XM Estate (Y4)</b>			<b>05/1994 → 10/2000</b>		
Control Arm-/Trailing Arm Bush	All Models		<b>F8-5150</b>		H=28; d=14; D=40
Engine Mounting	2.0 i 16V, 2.0 Turbo, 2.1 D12		<b>F8-5569</b>		
Belt Pulley, crankshaft	2.1 TD 12V	XUD11ATE, XUD11BTE; Orga.06779→; Orga.→07237;	<b>F8-5647</b>		
Engine Mounting	2.0 i 16V, 2.0 Turbo, 2.1 D12, 2.1 TD 12V		<b>F8-6236</b>		H1=53; H2=40; d=10; D=70
Belt Pulley, crankshaft	2.5 TD		<b>F8-6395</b>		
Engine Mounting	2.0 i 16V, 3.0 V6		<b>F8-6507</b>		
Engine Mounting	2.0 Turbo	XU10J2TE;	<b>F8-6507</b>		
Engine Mounting	2.1 TD 12V	XUD11ATE; Orga.→07237;	<b>F8-6507</b>		

<b>F8-5150</b>	<b>F8-5569</b>	<b>F8-5647</b>	<b>F8-6236</b>	<b>F8-6271</b>	<b>F8-6395</b>	<b>F8-6507</b>
Ref.Nr.: 3523.43	Ref.Nr.: 9604338880	Ref.Nr.: 0515J9	Ref.Nr.: 1809.21	Ref.Nr.:	Ref.Nr.: 0515.H3	Ref.Nr.: 1827.16
<b>F8-6857</b>	<b>F8-7011</b>	<b>F8-7083</b>	<b>F8-7874</b>	<b>F8-7980</b>	<b>LM-10072S</b>	
Ref.Nr.: 1827.22	Ref.Nr.: 1809.28	Ref.Nr.: 0515.K6	Ref.Nr.: 0515.S2	Ref.Nr.: 96 089 104	Ref.Nr.: 4066.30	



**Article Description****Article Nr.****Fitting Position**

<b>XM Estate (Y4)</b>			<b>05/1994 → 10/2000</b>		
Engine Mounting	3.0 V6	UFZ (ZPJ/Z);	<b>F8-6507</b>		
Engine Mounting	2.0 i 16V	07/1994 →;	<b>F8-6857</b>		
Engine Mounting	2.0 Turbo	ch.O06748→; 07/1994 →;  XU10J2TE;	<b>F8-6857</b>		
Holder, engine mounting	3.0 V6		<b>F8-7011</b>		d=10; L=53; D=69
Belt Pulley, crankshaft	2.0 i 16V	07/1994 →; Number of Ribs: 6	<b>F8-7083</b>		Belt Pulley Ø [mm]=127; Mounting points diam.[mm]=30; W=38
Belt Pulley, crankshaft	3.0 V6		<b>F8-7874</b>		
Bellow, steering	All Models	with clamps;	<b>LM-10072S</b>		d1=44; d2=44; L [mm]=120
<b>XSARA (N1)</b>			<b>04/1997 → 03/2005</b>		
Dust Cover Kit, shock absorber	1.4 i, 1.6 i, 1.8 D, 1.8 TD, 1.9 D, 1.9 SD, 1.9 TD		<b>AK-735010</b>		
Alternator Freewheel Clutch	2.0 HDi 109, 2.0 HDi 90		<b>F5-1020</b>		
Anti-Friction Bearing	1.4 HDi, 1.4 i, 1.5 D, 1.6 16V, 1.6 i, 1.8 D, 1.8 i, 1.8 i 16V, 1.8 i Aut., 1.8 TD, 1.8 VTS, 1.9 D, 1.9 SD, 1.9 TD, 2.0 16V, 2.0 HDi 109, 2.0 HDi 90		<b>F8-3012</b>		H=20; d=66; D=100
Anti-Friction Bearing	1.9 D	DW8B	<b>F8-3012</b>		H=20; d=66; D=100
Control Arm-/Trailing Arm Bush	1.4 HDi, 1.4 i, 1.5 D, 1.6 16V, 1.6 i, 1.8 D, 1.8 i, 1.8 i 16V, 1.8 i Aut., 1.8 TD, 1.9 D, 1.9 SD, 1.9 TD, 2.0 16V, 2.0 HDi 109, 2.0 HDi 90		<b>F8-5248</b>		
Mounting, axle beam	1.4 i, 1.5 D, 1.6 16V, 1.6 i, 1.8 D, 1.8 i, 1.8 i 16V, 1.8 i Aut., 1.8 TD, 1.9 D, 1.9 SD, 1.9 TD, 2.0 16V, 2.0 HDi 109, 2.0 HDi 90		<b>F8-5351</b>		
Mounting, axle beam	1.4 i, 1.5 D, 1.6 16V, 1.6 i, 1.8 D, 1.8 i, 1.8 i 16V, 1.8 i Aut., 1.8 TD, 1.9 D, 1.9 SD, 1.9 TD, 2.0 16V, 2.0 HDi 109, 2.0 HDi 90		<b>F8-5352</b>		
Control Arm-/Trailing Arm Bush	1.4 HDi, 1.4 i, 1.5 D, 1.6 16V, 1.6 i, 1.8 D, 1.8 i, 1.8 i 16V, 1.8 i Aut., 1.8 VTS, 1.9 D, 1.9 SD, 1.9 TD, 2.0 16V, 2.0 HDi 109, 2.0 HDi 90		<b>F8-5355</b>		
Engine Mounting	1.8 D, 1.8 i, 1.8 i 16V, 1.8 TD, 1.9 D, 1.9 SD, 1.9 TD, 2.0 16V, 2.0 HDi 90		<b>F8-5357</b>		
Engine Mounting	1.8 i Aut., 2.0 16V	07/1997 →	<b>F8-5357</b>		
Engine Mounting	1.9 D	DW8; Orga.→08239	<b>F8-5357</b>		
Engine Mounting	1.5 D, 1.8 i		<b>F8-5358</b>		
Engine Mounting	1.6 i		<b>F8-5358</b>		
Engine Mounting	1.9 D	DW8; Orga.08240→	<b>F8-5359</b>		
Control Arm-/Trailing Arm Bush	2.0 16V		<b>F8-5361</b>		
Mounting, axle beam	1.4 i, 1.5 D, 1.6 16V, 1.6 i, 1.8 D, 1.8 i, 1.8 i 16V, 1.8 i Aut., 1.9 D, 1.9 SD, 1.9 TD, 2.0 16V, 2.0 HDi 109, 2.0 HDi 90		<b>F8-5363</b>		

<b>AK-735010</b>	<b>F5-1020</b>	<b>F8-3012</b>	<b>F8-5248</b>	<b>F8-5351</b>	<b>F8-5352</b>	<b>F8-5355</b>
Ref.Nr.:	Ref.Nr.: 31771-68D01	Ref.Nr.: 503527	Ref.Nr.: 3523.59	Ref.Nr.: 513170	Ref.Nr.: 513169	Ref.Nr.: 3520.H5S1
<b>F8-5357</b>	<b>F8-5358</b>	<b>F8-5359</b>	<b>F8-5361</b>	<b>F8-5363</b>	<b>F8-5364</b>	<b>F8-6507</b>
Ref.Nr.: 1844.47	Ref.Nr.: 184373	Ref.Nr.: 182723	Ref.Nr.: 3523.83	Ref.Nr.: 5131.71	Ref.Nr.: 503821	Ref.Nr.: 1827.16
<b>F8-6857</b>	<b>F8-7011</b>	<b>F8-7083</b>	<b>F8-7874</b>	<b>LM-10072S</b>		
Ref.Nr.: 1827.22	Ref.Nr.: 1809.28	Ref.Nr.: 0515.K6	Ref.Nr.: 0515.S2	Ref.Nr.: 4066.30		

Article Description



Article Nr.

Fitting Position



XSARA (N1)		04/1997 → 03/2005	
Top Strut Mounting	1.4 HDi, 1.4 i, 1.5 D, 1.6 16V, 1.6 i, 1.8 D, 1.8 i, 1.8 i 16V, 1.8 i Aut., 1.9 D, 1.9 SD, 1.9 TD, 2.0 16V, 2.0 HDi 109, 2.0 HDi 90		F8-5364
Engine Mounting	1.4 i, 1.5 D, 1.6 i, 1.9 D, 2.0 16V, 2.0 HDi 109, 2.0 HDi 90		F8-5375
Top Strut Mounting	1.4 HDi, 1.4 i, 1.5 D, 1.6 16V, 1.6 i, 1.8 D, 1.8 i, 1.8 i 16V, 1.8 i Aut., 1.8 TD, 1.9 D, 1.9 SD, 1.9 TD, 2.0 16V, 2.0 HDi 109, 2.0 HDi 90		F8-5516
Top Strut Mounting	1.4 i, 1.5 D, 1.6 16V, 1.6 i, 1.8 D, 1.8 i, 1.8 i 16V, 1.8 i Aut., 1.8 TD, 1.9 D, 1.9 SD, 1.9 TD, 2.0 16V, 2.0 HDi 109, 2.0 HDi 90		F8-5517
Engine Mounting	1.4 i, 1.9 SD, 2.0 16V, 2.0 HDi 90		F8-5568
Engine Mounting	1.5 D, 1.6 i, 1.8 D, 1.8 i, 1.8 i 16V, 1.8 i Aut., 1.9 TD	07/1997 →	F8-5568
Engine Mounting	1.9 D	DW8	F8-5568
Belt Pulley, crankshaft	2.0 HDi 109		F8-5636
Belt Pulley, crankshaft	2.0 HDi 90		F8-5636
Belt Pulley, crankshaft	1.8 D, 1.9 D, 1.9 SD, 1.9 TD	Number of Ribs: 6	F8-5643
Belt Pulley, crankshaft	1.5 D		F8-5644
Belt Pulley, crankshaft	1.9 D	ch.→09519, 09894;	F8-5659
Engine Mounting	1.8 D, 1.8 i, 1.8 i Aut., 1.9 D, 1.9 TD, 2.0 16V, 2.0 HDi 109, 2.0 HDi 90		F8-6236
Engine Mounting	1.8 D, 1.8 i, 1.8 i 16V, 1.9 D, 1.9 TD, 2.0 16V, 2.0 HDi 90		F8-6237
Repair Kit, wheel suspension	1.4 HDi, 1.4 i, 1.5 D, 1.6 16V, 1.6 i, 1.8 D, 1.8 i, 1.8 i 16V, 1.8 i Aut., 1.8 TD, 1.8 VTS, 1.9 D, 1.9 SD, 1.9 TD, 2.0 16V, 2.0 HDi 109, 2.0 HDi 90		F8-6272
Top Strut Mounting	1.4 HDi, 1.4 i, 1.6 16V, 2.0 16V, 2.0 HDi 109, 2.0 HDi 90		F8-6296
Top Strut Mounting	1.5 D	01/1999 →;	F8-6296
Top Strut Mounting	1.6 i, 1.8 D, 1.8 i, 1.8 i 16V, 1.8 i Aut., 1.8 TD, 1.9 D, 1.9 SD, 1.9 TD	04/1999 →;	F8-6296
Top Strut Mounting	1.9 D	02/1999 →;	F8-6296
Top Strut Mounting	1.4 i, 1.6 16V, 2.0 16V, 2.0 HDi 109, 2.0 HDi 90	Type: Enterprise;	F8-6297
Top Strut Mounting	1.5 D, 1.6 i, 1.8 D, 1.8 i, 1.8 i 16V, 1.8 i Aut., 1.8 TD, 1.9 D, 1.9 SD, 1.9 TD, 2.0 16V		F8-6297
Belt Pulley, crankshaft	1.4 i, 1.6 16V	Number of Ribs: 5; Parameter: 6PK	F8-6394
Engine Mounting	1.4 HDi, 1.8 VTS, 2.0 16V, 2.0 HDi 109		F8-6486
Engine Mounting	1.9 D	DW8B	F8-6486
Engine Mounting	2.0 HDi 90	09/2000 →	F8-6486
Engine Mounting	1.4 i		F8-6487

F8-5364	F8-5375	F8-5516	F8-5517	F8-5568	F8-5636	F8-5643
Ref.Nr.: 503821	Ref.Nr.: 180906	Ref.Nr.: 503824	Ref.Nr.: 5038.23	Ref.Nr.: 184425	Ref.Nr.: 0515P2	Ref.Nr.: 96089 38980
F8-5644	F8-5659	F8-6236	F8-6237	F8-6272	F8-6296	F8-6297
Ref.Nr.: 0515L6	Ref.Nr.: 0515Q6	Ref.Nr.: 1809.21	Ref.Nr.: 1809.22	Ref.Nr.: 9556384280	Ref.Nr.: 503824	Ref.Nr.: 503527
F8-6394	F8-6486	F8-6487	F8-6497			
Ref.Nr.: 0515.R8	Ref.Nr.: 1844.77	Ref.Nr.: 184472	Ref.Nr.: 1844.75			

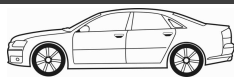
**Article Description****Article Nr.****Fitting Position**

<b>XSARA (N1)</b>		<b>04/1997 → 03/2005</b>	
Engine Mounting	1.6 16V, 1.6 i		<b>F8-6497</b> ⊕
Engine Mounting	1.4 HDi	DV4TD	<b>F8-6500</b> ⊕
Engine Mounting	1.8 D	XUD7	<b>F8-6500</b> ⊕
Engine Mounting	1.8 i Aut.	XU7JP	<b>F8-6500</b> ⊕
Engine Mounting	1.8 i, 1.8 i 16V, 1.9 SD, 1.9 TD, 2.0 16V, 2.0 HDi 109, 2.0 HDi 90		<b>F8-6500</b> ⊕
Engine Mounting	1.9 D	DW8, DW8B	<b>F8-6500</b> ⊕
Engine Mounting	1.9 D	XUD9A	<b>F8-6500</b> ⊕
Engine Mounting	2.0 16V		<b>F8-6500</b> ⊕
Mounting, automatic transmission	1.4 i, 1.5 D, 1.6 16V		<b>F8-6505</b> ⊕
Mounting, automatic transmission	1.6 i	07/1997 →	<b>F8-6505</b> ⊕
Engine Mounting	2.0 16V, 2.0 HDi 109		<b>F8-6507</b> ⊕
Belt Pulley, crankshaft	1.8 i 16V, 2.0 16V	Number of Ribs: 6	<b>F8-7083</b>
Belt Pulley, crankshaft	1.8 i Aut.	07/1997 →; Number of Ribs: 6	<b>F8-7084</b>
Rubber Buffer, suspension	1.4 HDi, 1.6 16V, 1.8 VTS, 1.9 D, 2.0 16V, 2.0 HDi 109		<b>F8-7589</b> ⊕ ⊕ ⊕ H=81
Rubber Buffer, suspension	1.8 D, 1.8 i, 1.8 i 16V, 1.8 i Aut., 1.9 D, 1.9 SD, 1.9 TD, 2.0 16V		<b>F8-7589</b> ⊕ ⊕ ⊕ H=81
Belt Pulley, crankshaft	1.9 D	Orga.09895→;	<b>F8-7862</b>
Stabiliser Mounting	1.4 HDi, 1.4 i, 1.5 D, 1.6 16V, 1.6 i, 1.8 D, 1.8 i, 1.8 i 16V, 1.8 i Aut., 1.8 TD, 1.9 D, 1.9 SD, 1.9 TD, 2.0 16V, 2.0 HDi 109, 2.0 HDi 90		<b>F8-7943</b> ⊕ ⊕ ⊕
Engine Mounting	1.4 HDi		<b>F8-8184</b> ⊕
Repair Kit, wheel suspension	1.4 HDi, 1.4 i, 1.5 D, 1.6 16V, 1.6 i, 1.8 D, 1.8 i, 1.8 i 16V, 1.8 i Aut., 1.8 TD, 1.8 VTS, 1.9 D, 1.9 SD, 1.9 TD, 2.0 16V, 2.0 HDi 109, 2.0 HDi 90		<b>G8-272</b> ⊕
Bellow, steering	1.4 HDi, 1.4 i, 1.5 D, 1.6 16V, 1.6 i, 1.8 D, 1.8 i, 1.8 i 16V, 1.8 i Aut., 1.8 VTS, 1.9 D, 1.9 SD, 1.9 TD, 2.0 16V, 2.0 HDi 109, 2.0 HDi 90	with clamps	<b>LM-10039S</b> ⊕ d1=40; d2=40; L [mm]=115
Bellow, steering	1.4 HDi, 1.4 i, 1.5 D, 1.6 16V, 1.6 i, 1.8 D, 1.8 i, 1.8 i 16V, 1.8 i Aut., 1.8 TD, 1.8 VTS, 1.9 D, 1.9 SD, 1.9 TD, 2.0 16V, 2.0 HDi 109, 2.0 HDi 90	with clamps;	<b>LM-10058S</b> ⊕ d1=11; d2=42; L [mm]=150
<b>XSARA Estate (N2)</b>		<b>10/1997 → 08/2005</b>	
Dust Cover Kit, shock absorber	1.4 i, 1.5 D, 1.6 i, 1.8 D, 1.8 i, 1.8 i 16V, 1.8 i Aut., 1.9 D, 1.9 TD, 2.0 16V, 2.0 HDi 90		<b>AK-735010</b> ⊕ ⊕ ⊕
Alternator Freewheel Clutch	2.0 HDi 109, 2.0 HDi 90		<b>F5-1020</b>

<b>AK-735010</b>	<b>F5-1020</b>	<b>F8-3012</b>	<b>F8-6497</b>	<b>F8-6500</b>	<b>F8-6505</b>	<b>F8-6507</b>
Ref.Nr.:	Ref.Nr.: 31771-68D01	Ref.Nr.: 503527	Ref.Nr.: 1844.75	Ref.Nr.: 1844.36	Ref.Nr.: 1844.51	Ref.Nr.: 1827.16
<b>F8-7083</b>	<b>F8-7084</b>	<b>F8-7589</b>	<b>F8-7862</b>	<b>F8-7943</b>	<b>F8-8184</b>	<b>G8-272</b>
Ref.Nr.: 0515.K6	Ref.Nr.: 0515.H6	Ref.Nr.: 9621916980	Ref.Nr.: 0515 R5	Ref.Nr.: 509479	Ref.Nr.: 1806.33	Ref.Nr.: 5132.49
<b>LM-10039S</b>	<b>LM-10058S</b>					
Ref.Nr.: 4066.22	Ref.Nr.: 4066.43					

Article Description



Article Nr.

Fitting Position



<b>XSARA Estate (N2)</b>		<b>10/1997 → 08/2005</b>	
Anti-Friction Bearing	1.4 HDi, 1.4 i, 1.5 D, 1.6 16V, 1.6 i, 1.8 D, 1.8 i, 1.8 i 16V, 1.8 i Aut., 1.9 D, 1.9 TD, 2.0 16V, 2.0 HDi 109, 2.0 HDi 90	F8-3012	H=20; d=66; D=100
Anti-Friction Bearing	1.9 D	DW8B	F8-3012  H=20; d=66; D=100
Control Arm-/Trailing Arm Bush	1.4 i, 1.5 D, 1.6 16V, 1.6 i, 1.8 D, 1.8 i, 1.8 i 16V, 1.8 i Aut., 1.9 D, 1.9 TD, 2.0 16V, 2.0 HDi 109, 2.0 HDi 90	F8-5248	
Mounting, axle beam	1.4 i, 1.5 D, 1.6 16V, 1.6 i, 1.8 D, 1.8 i, 1.8 i 16V, 1.8 i Aut., 1.9 D, 1.9 TD, 2.0 16V, 2.0 HDi 109, 2.0 HDi 90	F8-5351	
Mounting, axle beam	1.4 i, 1.5 D, 1.6 16V, 1.6 i, 1.8 D, 1.8 i, 1.8 i 16V, 1.8 i Aut., 1.9 D, 1.9 TD, 2.0 16V, 2.0 HDi 109, 2.0 HDi 90	F8-5352	
Control Arm-/Trailing Arm Bush	1.4 HDi, 1.4 i, 1.5 D, 1.6 16V, 1.6 i, 1.8 D, 1.8 i, 1.8 i 16V, 1.8 i Aut., 1.9 D, 1.9 TD, 2.0 16V, 2.0 HDi 90	F8-5355	
Engine Mounting	1.8 D, 1.8 i, 1.8 i 16V, 1.8 i Aut., 1.9 D, 1.9 TD, 2.0 16V, 2.0 HDi 90	F8-5357	
Engine Mounting	1.9 D	DW8; Orga.→08239	F8-5357
Engine Mounting	1.5 D, 1.8 i	F8-5358	
Engine Mounting	1.6 i	DW8	F8-5358
Engine Mounting	1.9 D	DW8; Orga.08240→	F8-5359
Control Arm-/Trailing Arm Bush	2.0 16V	F8-5361	
Mounting, axle beam	1.4 i, 1.5 D, 1.6 16V, 1.6 i, 1.8 D, 1.8 i, 1.8 i 16V, 1.8 i Aut., 1.9 D, 1.9 TD, 2.0 16V, 2.0 HDi 109, 2.0 HDi 90	F8-5363	
Top Strut Mounting	1.4 HDi, 1.4 i, 1.5 D, 1.6 16V, 1.6 i, 1.8 D, 1.8 i, 1.8 i 16V, 1.8 i Aut., 1.9 D, 1.9 TD, 2.0 16V, 2.0 HDi 109, 2.0 HDi 90	F8-5364	
Engine Mounting	1.4 i, 1.5 D, 1.6 i, 1.9 D, 2.0 16V, 2.0 HDi 109, 2.0 HDi 90	F8-5375	H=34; d=12; D=30
Top Strut Mounting	1.4 HDi, 1.6 16V, 2.0 16V, 2.0 HDi 109	F8-5516	
Top Strut Mounting	1.4 i, 1.5 D, 1.6 i, 1.8 D, 1.8 i, 1.8 i 16V, 1.8 i Aut., 1.9 D, 1.9 TD, 2.0 16V, 2.0 HDi 90	F8-5517	
Engine Mounting	1.4 i, 1.5 D, 1.6 i, 1.8 D, 1.8 i, 1.8 i 16V, 1.8 i Aut., 1.9 D, 1.9 TD, 2.0 16V, 2.0 HDi 90	F8-5568	
Engine Mounting	1.9 D	DW8	F8-5568
Belt Pulley, crankshaft	2.0 HDi 109	F8-5636	d=30
Belt Pulley, crankshaft	2.0 HDi 90	DW8	F8-5636  d=30
Belt Pulley, crankshaft	1.8 D, 1.9 D, 1.9 TD	Number of Ribs: 6	F8-5643  Belt Pulley Ø [mm]=156; W=44
Belt Pulley, crankshaft	1.5 D	F8-5644	
Belt Pulley, crankshaft	1.9 D	ch.→09519, 09894;  DW8	F8-5659
Engine Mounting	1.8 D, 1.8 i, 1.8 i Aut., 1.9 D, 1.9 TD, 2.0 16V, 2.0 HDi 109, 2.0 HDi 90	F8-6236	H1=53; H2=40; d=10; D=70
Engine Mounting	1.8 D, 1.8 i, 1.8 i 16V, 1.9 D, 1.9 TD, 2.0 16V, 2.0 HDi 90	F8-6237	

<b>F8-3012</b>	<b>F8-5248</b>	<b>F8-5351</b>	<b>F8-5352</b>	<b>F8-5355</b>	<b>F8-5357</b>	<b>F8-5358</b>
Ref.Nr.: 503527	Ref.Nr.: 3523.59	Ref.Nr.: 513170	Ref.Nr.: 513169	Ref.Nr.: 3520.H5S1	Ref.Nr.: 1844.47	Ref.Nr.: 184373
<b>F8-5359</b>	<b>F8-5361</b>	<b>F8-5363</b>	<b>F8-5364</b>	<b>F8-5375</b>	<b>F8-5516</b>	<b>F8-5517</b>
Ref.Nr.: 182723	Ref.Nr.: 3523.83	Ref.Nr.: 5131.71	Ref.Nr.: 503821	Ref.Nr.: 180906	Ref.Nr.: 503824	Ref.Nr.: 5038.23
<b>F8-5568</b>	<b>F8-5636</b>	<b>F8-5643</b>	<b>F8-5644</b>	<b>F8-5659</b>	<b>F8-6236</b>	<b>F8-6237</b>
Ref.Nr.: 184425	Ref.Nr.: 0515P2	Ref.Nr.: 96089 38980	Ref.Nr.: 0515L6	Ref.Nr.: 0515Q6	Ref.Nr.: 1809.21	Ref.Nr.: 1809.22

**Article Description****Article Nr.****Fitting Position**

<b>XSARA Estate (N2)</b>		<b>10/1997 → 08/2005</b>			
Repair Kit, wheel suspension	1.4 HDi, 1.4 i, 1.5 D, 1.6 16V, 1.6 i, 1.8 D, 1.8 i, 1.8 i 16V, 1.8 i Aut., 1.9 D, 1.9 TD, 2.0 16V, 2.0 HDi 109, 2.0 HDi 90		<b>F8-6272</b>		
Top Strut Mounting	1.4 HDi, 1.6 16V, 2.0 16V, 2.0 HDi 109		<b>F8-6296</b>		
Top Strut Mounting	1.4 i, 1.5 D, 1.6 i, 1.8 D, 1.8 i, 1.8 i 16V, 1.8 i Aut., 1.9 D, 1.9 TD, 2.0 16V, 2.0 HDi 90		<b>F8-6297</b>		
Belt Pulley, crankshaft	1.4 i, 1.6 16V	Number of Ribs: 5; Parameter: 6PK	<b>F8-6394</b>		H=25; d=44.05; Mounting points diam.[mm]=9; D=148; D1=142.9
Engine Mounting	1.4 HDi, 2.0 16V, 2.0 HDi 109		<b>F8-6486</b>		
Engine Mounting	1.9 D	DW8B	<b>F8-6486</b>		
Engine Mounting	2.0 HDi 90	09/2000 →	<b>F8-6486</b>		
Engine Mounting	1.4 i		<b>F8-6487</b>		
Engine Mounting	1.6 16V, 1.6 i		<b>F8-6497</b>		
Engine Mounting	1.4 HDi	DV4TD	<b>F8-6500</b>		
Engine Mounting	1.8 D, 1.8 i, 1.8 i 16V, 1.9 D, 1.9 TD, 2.0 16V, 2.0 HDi 109, 2.0 HDi 90		<b>F8-6500</b>		
Engine Mounting	1.8 i Aut.	XU7JP	<b>F8-6500</b>		
Engine Mounting	1.9 D	DW8, DW8B	<b>F8-6500</b>		
Engine Mounting	1.9 D	XUD9A	<b>F8-6500</b>		
Engine Mounting	2.0 16V		<b>F8-6500</b>		
Mounting, automatic transmission	1.4 i, 1.5 D, 1.6 16V, 1.6 i		<b>F8-6505</b>		
Engine Mounting	2.0 16V, 2.0 HDi 109		<b>F8-6507</b>		
Belt Pulley, crankshaft	1.8 i 16V, 2.0 16V	Number of Ribs: 6	<b>F8-7083</b>		Belt Pulley Ø [mm]=127; Mounting points diam.[mm]=30; W=38
Belt Pulley, crankshaft	1.8 i Aut.	03/1998 →; Number of Ribs: 6	<b>F8-7084</b>		Belt Pulley Ø [mm]=127; Mounting points diam.[mm]=30; W=45
Rubber Buffer, suspension	1.4 HDi, 1.6 16V, 2.0 HDi 109	Orga.08688 →;	<b>F8-7589</b>		H=81
Rubber Buffer, suspension	1.4 i, 1.5 D, 1.6 i, 1.8 D, 1.8 i, 1.8 i 16V, 1.8 i Aut., 1.9 D, 1.9 TD, 2.0 16V, 2.0 HDi 90		<b>F8-7589</b>		H=81
Rubber Buffer, suspension	1.9 D	01/2000 →; Orga.08688 →;	<b>F8-7589</b>		H=81
Belt Pulley, crankshaft	1.9 D	Orga.09895 →;	<b>F8-7862</b>		
Stabiliser Mounting	1.4 HDi, 1.4 i, 1.5 D, 1.6 16V, 1.6 i, 1.8 D, 1.8 i, 1.8 i 16V, 1.8 i Aut., 1.9 D, 1.9 TD, 2.0 16V, 2.0 HDi 109, 2.0 HDi 90		<b>F8-7943</b>		
Engine Mounting	1.4 HDi		<b>F8-8184</b>		
Repair Kit, wheel suspension	All Models		<b>G8-272</b>		

<b>F8-6272</b>	<b>F8-6296</b>	<b>F8-6297</b>	<b>F8-6394</b>	<b>F8-6486</b>	<b>F8-6487</b>	<b>F8-6497</b>
Ref.Nr.: 9556384280	Ref.Nr.: 503824	Ref.Nr.: 503527	Ref.Nr.: 0515.R8	Ref.Nr.: 1844.77	Ref.Nr.: 184472	Ref.Nr.: 1844.75
<b>F8-6500</b>	<b>F8-6505</b>	<b>F8-6507</b>	<b>F8-7083</b>	<b>F8-7084</b>	<b>F8-7589</b>	<b>F8-7862</b>
Ref.Nr.: 1844.36	Ref.Nr.: 1844.51	Ref.Nr.: 1827.16	Ref.Nr.: 0515.K6	Ref.Nr.: 0515.H6	Ref.Nr.: 9621916980	Ref.Nr.: 0515 R5
<b>F8-7943</b>	<b>F8-8184</b>	<b>G8-272</b>	<b>LM-10039S</b>			
Ref.Nr.: 509479	Ref.Nr.: 1806.33	Ref.Nr.: 5132.49	Ref.Nr.: 4066.22			

Article Description



Article Nr.

Fitting Position



<b>XSARA Estate (N2)</b>				<b>10/1997 → 08/2005</b>	
Bellow, steering	1.4 HDi, 1.4 i, 1.5 D, 1.6 16V, 1.6 i, 1.8 D, 1.8 i, 1.8 i 16V, 1.8 i Aut., 1.9 D, 1.9 TD, 2.0 16V, 2.0 HDi 109, 2.0 HDi 90	with clamps		<b>LM-10039S</b>	d1=40; d2=40; L [mm]=115
Bellow, steering	1.4 HDi, 1.4 i, 1.5 D, 1.6 16V, 1.6 i, 1.8 D, 1.8 i, 1.8 i 16V, 1.8 i Aut., 1.9 D, 1.9 TD, 2.0 16V, 2.0 HDi 109, 2.0 HDi 90	with clamps;		<b>LM-10058S</b>	d1=11; d2=42; L [mm]=150
<b>XSARA Coupe (N0)</b>				<b>02/1998 → 03/2005</b>	
Dust Cover Kit, shock absorber	1.4 i, 1.9 D, 1.9 TD			<b>AK-735010</b>	
Alternator Freewheel Clutch	2.0 HDi 109, 2.0 HDi 90			<b>F5-1020</b>	
Anti-Friction Bearing	1.4 HDi, 1.4 i, 1.6 16V, 1.6 i, 1.8 i, 1.8 i 16V, 1.8 VTS, 1.9 D, 1.9 TD, 2.0, 2.0 16V, 2.0 HDi 109, 2.0 HDi 90, 2.0 i 16V			<b>F8-3012</b>	H=20; d=66; D=100
Anti-Friction Bearing	1.9 D	DW8		<b>F8-3012</b>	H=20; d=66; D=100
Control Arm-/Trailing Arm Bush	1.4 HDi, 1.4 i, 1.6 16V, 1.6 i, 1.8 i, 1.8 i 16V, 1.9 D, 1.9 TD, 2.0 16V, 2.0 HDi 109, 2.0 HDi 90, 2.0 i 16V			<b>F8-5248</b>	
Mounting, axle beam	1.4 i, 1.6 16V, 1.6 i, 1.8 i, 1.8 i 16V, 1.9 D, 1.9 TD, 2.0 16V, 2.0 HDi 109, 2.0 HDi 90, 2.0 i 16V			<b>F8-5351</b>	
Mounting, axle beam	1.4 i, 1.6 16V, 1.6 i, 1.8 i, 1.8 i 16V, 1.9 D, 1.9 TD, 2.0 16V, 2.0 HDi 109, 2.0 HDi 90, 2.0 i 16V			<b>F8-5352</b>	
Control Arm-/Trailing Arm Bush	1.4 HDi, 1.4 i, 1.6 16V, 1.6 i, 1.8 i, 1.8 i 16V, 1.8 VTS, 1.9 D, 1.9 TD, 2.0, 2.0 16V, 2.0 HDi 90, 2.0 i 16V			<b>F8-5355</b>	
Engine Mounting	1.8 i, 1.8 i 16V, 1.9 D, 1.9 TD, 2.0, 2.0 HDi 90, 2.0 i 16V			<b>F8-5357</b>	
Engine Mounting	1.9 D	Orga.→08239		<b>F8-5357</b>	
Engine Mounting	1.9 D	DW8; Orga.→08239		<b>F8-5357</b>	
Engine Mounting	1.6 i			<b>F8-5358</b>	
Engine Mounting	1.8 i			<b>F8-5358</b>	
Engine Mounting	1.9 D	DW8; Orga.08240→		<b>F8-5359</b>	
Control Arm-/Trailing Arm Bush	1.6 16V, 2.0 16V			<b>F8-5361</b>	
Mounting, axle beam	1.4 i, 1.6 16V, 1.6 i, 1.8 i, 1.8 i 16V, 1.9 D, 1.9 TD, 2.0 16V, 2.0 HDi 109, 2.0 HDi 90, 2.0 i 16V			<b>F8-5363</b>	
Top Strut Mounting	1.4 HDi, 1.4 i, 1.6 16V, 1.6 i, 1.8 i, 1.8 i 16V, 1.9 D, 1.9 TD, 2.0 16V, 2.0 HDi 109, 2.0 HDi 90, 2.0 i 16V			<b>F8-5364</b>	
Engine Mounting	1.4 i, 1.6 i, 1.9 D, 2.0 16V, 2.0 HDi 109, 2.0 HDi 90			<b>F8-5375</b>	H=34; d=12; D=30
Top Strut Mounting	1.4 HDi, 1.4 i, 1.6 16V, 1.8 i, 1.8 i 16V, 1.9 D, 1.9 TD, 2.0 16V, 2.0 HDi 109, 2.0 HDi 90			<b>F8-5516</b>	
Top Strut Mounting	1.4 i, 1.8 i, 1.8 i 16V, 1.9 D, 1.9 TD, 2.0 i 16V			<b>F8-5517</b>	
Engine Mounting	1.4 i, 1.8 i, 1.8 i 16V, 1.9 TD, 2.0 HDi 90			<b>F8-5568</b>	
Engine Mounting	1.9 D	DW8		<b>F8-5568</b>	
Belt Pulley, crankshaft	2.0 HDi 109			<b>F8-5636</b>	d=30

<b>AK-735010</b>	<b>F5-1020</b>	<b>F8-3012</b>	<b>F8-5248</b>	<b>F8-5351</b>	<b>F8-5352</b>	<b>F8-5355</b>
Ref.Nr.: <b>AK-735010</b>	Ref.Nr.: <b>31771-68D01</b>	Ref.Nr.: <b>503527</b>	Ref.Nr.: <b>3523.59</b>	Ref.Nr.: <b>513170</b>	Ref.Nr.: <b>513169</b>	Ref.Nr.: <b>3520.H5S1</b>
<b>F8-5357</b>	<b>F8-5358</b>	<b>F8-5359</b>	<b>F8-5361</b>	<b>F8-5363</b>	<b>F8-5364</b>	<b>F8-5375</b>
Ref.Nr.: <b>1844.47</b>	Ref.Nr.: <b>184373</b>	Ref.Nr.: <b>182723</b>	Ref.Nr.: <b>3523.83</b>	Ref.Nr.: <b>5131.71</b>	Ref.Nr.: <b>503821</b>	Ref.Nr.: <b>180906</b>
<b>F8-5516</b>	<b>F8-5517</b>	<b>F8-5568</b>	<b>F8-5636</b>	<b>LM-10039S</b>	<b>LM-10058S</b>	
Ref.Nr.: <b>503824</b>	Ref.Nr.: <b>5038.23</b>	Ref.Nr.: <b>184425</b>	Ref.Nr.: <b>0515P2</b>	Ref.Nr.: <b>4066.22</b>	Ref.Nr.: <b>4066.43</b>	



Article Description



Article Nr.

Fitting Position



XSARA Coupe (N0)			02/1998 → 03/2005		
Belt Pulley, crankshaft	2.0 HDi 90		<b>F8-5636</b>		d=30
Belt Pulley, crankshaft	1.9 D, 1.9 TD	Number of Ribs: 6	<b>F8-5643</b>		Belt Pulley Ø [mm]=156; W=44
Belt Pulley, crankshaft	1.9 D	ch.→09519, 09894;	<b>F8-5659</b>		
Engine Mounting	1.8 i, 1.9 D, 1.9 TD, 2.0, 2.0 HDi 109, 2.0 HDi 90		<b>F8-6236</b>		H1=53; H2=40; d=10; D=70
Engine Mounting	1.8 i, 1.8 i 16V, 1.9 D, 1.9 TD, 2.0, 2.0 HDi 90, 2.0 i 16V		<b>F8-6237</b>		
Repair Kit, wheel suspension	All Models		<b>F8-6272</b>		
Top Strut Mounting	1.4 HDi, 1.4 i, 1.6 16V, 1.8 i, 1.9 D, 2.0 16V, 2.0 HDi 109, 2.0 HDi 90		<b>F8-6296</b>		
Top Strut Mounting	1.8 i, 1.8 i 16V, 1.9 D, 1.9 TD	01/1999 →;	<b>F8-6296</b>		
Top Strut Mounting	1.4 i, 1.6 i, 1.8 i, 1.8 i 16V, 1.9 D, 1.9 TD, 2.0 i 16V		<b>F8-6297</b>		
Belt Pulley, crankshaft	1.4 i, 1.6 16V	Number of Ribs: 5; Parameter: 6PK	<b>F8-6394</b>		H=25; d=44,05; Mounting points diam.[mm]=9; D=148; D1=142.9
Engine Mounting	1.4 HDi, 1.8 VTS, 2.0 16V, 2.0 HDi 109		<b>F8-6486</b>		
Engine Mounting	1.9 D	DW8B	<b>F8-6486</b>		
Engine Mounting	2.0 HDi 90, 2.0 i 16V	09/2000 →	<b>F8-6486</b>		
Engine Mounting	1.4 i		<b>F8-6487</b>		
Engine Mounting	1.6 16V, 1.6 i		<b>F8-6497</b>		
Engine Mounting	1.4 HDi	DV4TD	<b>F8-6500</b>		
Engine Mounting	1.8 i	XU7JP	<b>F8-6500</b>		
Engine Mounting	1.8 i, 1.8 i 16V, 1.9 TD, 2.0, 2.0 HDi 109, 2.0 HDi 90, 2.0 i 16V		<b>F8-6500</b>		
Engine Mounting	1.9 D	DW8, DW8B	<b>F8-6500</b>		
Engine Mounting	1.9 D	XUD 9BS D	<b>F8-6500</b>		
Engine Mounting	1.9 D	XUD9A	<b>F8-6500</b>		
Engine Mounting	2.0 16V		<b>F8-6500</b>		
Mounting, automatic transmission	1.4 i, 1.6 16V, 1.6 i		<b>F8-6505</b>		
Engine Mounting	2.0 16V, 2.0 HDi 109		<b>F8-6507</b>		
Belt Pulley, crankshaft	1.8 i 16V, 2.0 16V	Number of Ribs: 6	<b>F8-7083</b>		Belt Pulley Ø [mm]=127; Mounting points diam.[mm]=30; W=38
Belt Pulley, crankshaft	1.8 i	Number of Ribs: 6	<b>F8-7084</b>		Belt Pulley Ø [mm]=127; Mounting points diam.[mm]=30; W=45
Belt Pulley, crankshaft	1.9 D	Orga.09895→;	<b>F8-7862</b>		
Stabiliser Mounting	1.4 HDi, 1.4 i, 1.6 16V, 1.6 i, 1.8 i, 1.8 i 16V, 1.9 D, 1.9 TD, 2.0 16V, 2.0 HDi 109, 2.0 HDi 90, 2.0 i 16V		<b>F8-7943</b>		
Engine Mounting	1.4 HDi		<b>F8-8184</b>		

<b>F8-5636</b>	<b>F8-5643</b>	<b>F8-5659</b>	<b>F8-6236</b>	<b>F8-6237</b>	<b>F8-6272</b>	<b>F8-6296</b>
Ref.Nr.: 0515P2	Ref.Nr.: 96089 38980	Ref.Nr.: 0515Q6	Ref.Nr.: 1809.21	Ref.Nr.: 1809.22	Ref.Nr.: 9556384280	Ref.Nr.: 503824
<b>F8-6297</b>	<b>F8-6394</b>	<b>F8-6486</b>	<b>F8-6487</b>	<b>F8-6497</b>	<b>F8-6500</b>	<b>F8-6505</b>
Ref.Nr.: 503527	Ref.Nr.: 0515.R8	Ref.Nr.: 1844.77	Ref.Nr.: 184472	Ref.Nr.: 1844.75	Ref.Nr.: 1844.36	Ref.Nr.: 1844.51
<b>F8-6507</b>	<b>F8-7083</b>	<b>F8-7084</b>	<b>F8-7862</b>	<b>F8-7943</b>	<b>F8-8184</b>	<b>G8-272</b>
Ref.Nr.: 1827.16	Ref.Nr.: 0515.K6	Ref.Nr.: 0515.H6	Ref.Nr.: 0515 R5	Ref.Nr.: 509479	Ref.Nr.: 1806.33	Ref.Nr.: 5132.49

Article Description

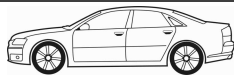

Article Nr.

Fitting Position



<b>XSARA Coupe (N0)</b>			<b>02/1998 → 03/2005</b>	
Repair Kit, wheel suspension	All Models		<b>G8-272</b>	
Bellow, steering	All Models	with clamps	<b>LM-10039S</b>	d1=40; d2=40; L [mm]=115
Bellow, steering	All Models	with clamps;	<b>LM-10058S</b>	d1=11; d2=42; L [mm]=150
<b>XSARA Box</b>			<b>09/2000 → 03/2005</b>	
Anti-Friction Bearing	All Models		<b>F8-3012</b>	H=20; d=66; D=100
Repair Kit, wheel suspension	All Models		<b>F8-6272</b>	
Engine Mounting	All Models		<b>F8-6500</b>	
Repair Kit, wheel suspension	All Models		<b>G8-272</b>	
Bellow, steering	All Models	with clamps	<b>LM-10039S</b>	d1=40; d2=40; L [mm]=115
<b>XSARA PICASSO (N68)</b>			<b>12/1999 → 09/2006</b>	
Dust Cover Kit, shock absorber	1.6, 1.6 16V, 1.6 Chrono, 1.6 HDi, 1.8 16V, 1.8 SX, 2.0 16V, 2.0 HDi		<b>AK-735010</b>	
Alternator Freewheel Clutch	2.0 HDi		<b>F5-1020</b>	
Alternator Freewheel Clutch	1.6 HDi, 2.0 HDi		<b>F5-1046</b>	
Alternator Freewheel Clutch	1.6 HDi		<b>F5-1048</b>	
Anti-Friction Bearing	1.6, 1.6 16V, 1.6 Chrono, 1.6 HDi, 1.8 SX, 2.0 16V, 2.0 HDi		<b>F8-3012</b>	H=20; d=66; D=100
Anti-Friction Bearing	1.8 16V	EW7J4	<b>F8-3012</b>	H=20; d=66; D=100
Control Arm-/Trailing Arm Bush	1.6, 1.8 16V, 2.0 HDi		<b>F8-5248</b>	
Mounting, axle beam	1.6, 1.8 16V, 2.0 HDi		<b>F8-5351</b>	
Mounting, axle beam	1.6, 1.8 16V, 2.0 HDi		<b>F8-5352</b>	
Control Arm-/Trailing Arm Bush	1.6, 1.6 16V, 1.6 HDi, 1.8 16V, 1.8 SX, 2.0 16V, 2.0 HDi		<b>F8-5355</b>	
Control Arm-/Trailing Arm Bush	1.6, 1.6 16V, 1.6 HDi, 1.8 16V, 1.8 SX, 2.0 16V, 2.0 HDi		<b>F8-5361</b>	
Engine Mounting	1.8 16V, 2.0 16V		<b>F8-5375</b>	H=34; d=12; D=30
Engine Mounting	2.0 HDi	06/2000 →	<b>F8-5375</b>	H=34; d=12; D=30
Top Strut Mounting	1.6		<b>F8-5516</b>	
Top Strut Mounting	1.6, 2.0 HDi	ch.→O09092; 06/2000 →;	<b>F8-5516</b>	
Top Strut Mounting	1.8 16V	ch.→O09092;	<b>F8-5516</b>	
Belt Pulley, crankshaft	2.0 HDi		<b>F8-5636</b>	d=30
Engine Mounting	2.0 HDi		<b>F8-6236</b>	H1=53; H2=40; d=10; D=70
Repair Kit, wheel suspension	All Models		<b>F8-6276</b>	
Top Strut Mounting	1.6, 1.6 16V, 1.6 HDi, 1.8 16V, 2.0 16V, 2.0 HDi		<b>F8-6296</b>	
Belt Pulley, crankshaft	1.6	Number of Ribs: 5; Parameter: 6PK;	<b>F8-6394</b>	H=25; d=44.05; Mounting points diam.[mm]=9; D=148; D1=142.9

<b>AK-735010</b>	<b>F5-1020</b>	<b>F5-1046</b>	<b>F5-1048</b>	<b>F8-3012</b>	<b>F8-5248</b>	<b>F8-5351</b>
Ref.Nr.:	Ref.Nr.: 31771-68D01	Ref.Nr.: 30667687	Ref.Nr.: 77363468	Ref.Nr.: 503527	Ref.Nr.: 3523.59	Ref.Nr.: 513170
<b>F8-5352</b>	<b>F8-5355</b>	<b>F8-5361</b>	<b>F8-5375</b>	<b>F8-5516</b>	<b>F8-5636</b>	<b>F8-6236</b>
Ref.Nr.: 513169	Ref.Nr.: 3520.H5S1	Ref.Nr.: 3523.83	Ref.Nr.: 180906	Ref.Nr.: 503824	Ref.Nr.: 0515P2	Ref.Nr.: 1809.21
<b>F8-6272</b>	<b>F8-6276</b>	<b>F8-6296</b>	<b>F8-6394</b>	<b>F8-6500</b>	<b>G8-272</b>	<b>LM-10039S</b>
Ref.Nr.: 9556384280	Ref.Nr.: 9612314280	Ref.Nr.: 503824	Ref.Nr.: 0515.R8	Ref.Nr.: 1844.36	Ref.Nr.: 5132.49	Ref.Nr.: 4066.22



**Article Description****Article Nr.****Fitting Position****XSARA PICASSO (N68) 12/1999 → 09/2006**

Belt Pulley, crankshaft	1.6, 1.6 16V	Number of Ribs: 5; Parameter: 6PK	<b>F8-6394</b>		H=25; d=44.05; Mounting points diam.[mm]=9; D=148; D1=142.9
Engine Mounting	1.6 HDi	Orga.→10289	<b>F8-6486</b>	⊕	
Engine Mounting	1.8 16V	EW7J4	<b>F8-6486</b>	⊕	
Engine Mounting	2.0 16V, 2.0 HDi		<b>F8-6486</b>	⊕	
Engine Mounting	1.6 HDi	Orga.10290→	<b>F8-6497</b>	⊕	
Engine Mounting	1.6, 1.6 16V		<b>F8-6497</b>	⊕	
Engine Mounting	1.6 HDi	DV6TED4	<b>F8-6500</b>	⊕	
Engine Mounting	1.6, 1.6 16V, 1.8 16V, 2.0 HDi		<b>F8-6500</b>	⊕	
Engine Mounting	1.6, 1.6 Chrono	TU5JP	<b>F8-6500</b>	⊕	
Engine Mounting	1.8 SX	XU7JP	<b>F8-6500</b>	⊕	
Engine Mounting	2.0 16V	ch.O09478→	<b>F8-6500</b>	⊕	
Engine Mounting	2.0 16V		<b>F8-6507</b>	⊕	
Belt Pulley, crankshaft	1.6 HDi	Number of Ribs: 6	<b>F8-7082</b>		Belt Pulley Ø [mm]=152; Mounting points diam.[mm]=30; W=34
Belt Pulley, crankshaft	1.6 HDi	Number of Ribs: 6; Orga.→10569	<b>F8-7082</b>		Belt Pulley Ø [mm]=152; Mounting points diam.[mm]=30; W=34
Rubber Buffer, suspension	1.6, 1.6 16V, 1.6 Chrono, 1.6 HDi, 1.8 16V, 1.8 SX, 2.0 16V, 2.0 HDi		<b>F8-7589</b>	⊕ ⊕	H=81
Belt Pulley, crankshaft	1.6 HDi	Number of Ribs: 5; Orga.10570→; Parameter: 6PK	<b>F8-7645</b>		D=157.75
Belt Pulley, crankshaft	1.6 HDi	Number of Ribs: 5; Parameter: 6PK	<b>F8-7645</b>		D=157.75
Engine Mounting	1.6 HDi		<b>F8-8184</b>	⊕	
Repair Kit, wheel suspension	All Models		<b>G8-276-5017</b>	⊕ ⊕	H=197; d=34; D=50,17
Repair Kit, wheel suspension	All Models		<b>G8-276-5020</b>	⊕ ⊕	H=197; d=34; D=50,2
Bellow, steering	1.6, 1.6 16V, 1.6 Chrono, 1.6 HDi, 1.8 16V, 1.8 SX, 2.0 16V, 2.0 HDi	with clamps	<b>LM-10039S</b>		d1=40; d2=40; L [mm]=115
Bellow, steering	1.6, 1.6 16V, 1.6 Chrono, 1.6 HDi, 1.8 16V, 1.8 SX, 2.0 16V, 2.0 HDi	with clamps;	<b>LM-10058S</b>		d1=11; d2=42; L [mm]=150

**ZX (N2) 03/1991 → 10/1997**

Dust Cover Kit, shock absorber	1,1, 1.1, 1.4, 1.4 D, 1.4 i, 1.6 i, 1.8 D, 1.8 i, 1.8 i 16V, 1.9, 1.9 D, 1.9 i, 1.9 TD, 2.0 i, 2.0 i 16V		<b>AK-735010</b>	⊕ ⊕	
Anti-Friction Bearing	1,1, 1.1, 1.4, 1.4 D, 1.8, 1.8 D, 1.8 i, 1.8 i 16V, 1.9 D, 1.9 i, 1.9 TD, 2.0, 2.0 i, 2.0 i 16V		<b>F8-3012</b>	⊕ ⊕	H=20; d=66; D=100
Anti-Friction Bearing	1.4 i	TU3JP	<b>F8-3012</b>	⊕ ⊕	H=20; d=66; D=100
Anti-Friction Bearing	1.6 i	XU5JP	<b>F8-3012</b>	⊕ ⊕	H=20; d=66; D=100

<b>AK-735010</b>	<b>F8-3012</b>	<b>F8-5213</b>	<b>F8-6394</b>	<b>F8-6486</b>	<b>F8-6497</b>	<b>F8-6500</b>
Ref.Nr.:	Ref.Nr.: 503527	Ref.Nr.: 5094.65	Ref.Nr.: 0515.R8	Ref.Nr.: 1844.77	Ref.Nr.: 1844.75	Ref.Nr.: 1844.36
<b>F8-6507</b>	<b>F8-7082</b>	<b>F8-7589</b>	<b>F8-7645</b>	<b>F8-8184</b>	<b>G8-276-5017</b>	<b>G8-276-5020</b>
Ref.Nr.: 1827.16	Ref.Nr.: 0515.R0	Ref.Nr.: 9621916980	Ref.Nr.: 0515.T3	Ref.Nr.: 1806.33	Ref.Nr.: 5132.73	Ref.Nr.: 514851
<b>LM-10039S</b>	<b>LM-10058S</b>					
Ref.Nr.: 4066.22	Ref.Nr.: 4066.43					

Article Description



Article Nr.

Fitting Position



ZX (N2)		03/1991 → 10/1997	
Stabiliser Mounting	1.1, 1.4, 1.8 D, 2.0 i 16V	F8-5213	d=21
Stabiliser Mounting	1.4 i, 1.6 i, 1.8 i, 1.8 i 16V, 1.9 D, 1.9 i, 1.9 TD, 2.0 i, 2.0 i 16V	F8-5213	D=21; d=21
Control Arm-/Trailing Arm Bush	1.1, 1.1, 1.4, 1.4 i, 1.6 i, 1.8 D, 1.8 i, 1.8 i 16V, 1.9 D, 1.9 i, 1.9 TD, 2.0 i, 2.0 i 16V	F8-5248	
Engine Mounting	1.1, 1.4, 1.4 i	F8-5347	
Mounting, axle beam	1.1, 1.4 i, 1.6 i, 1.8 D, 1.8 i, 1.8 i 16V, 1.9 D, 1.9 i, 1.9 TD, 2.0 i, 2.0 i 16V	F8-5351	
Mounting, axle beam	1.1, 1.4, 1.4 i, 1.6 i, 1.8 D, 1.8 i, 1.8 i 16V, 1.9 D, 1.9 i, 1.9 TD, 2.0 i, 2.0 i 16V	F8-5352	
Control Arm-/Trailing Arm Bush	1.1, 1.1, 1.4 D, 1.4 i, 1.6 i, 1.8 D, 1.8 i, 1.8 i 16V, 1.9 D, 1.9 i, 1.9 TD, 2.0, 2.0 i, 2.0 i 16V	F8-5355	
Bellow, driveshaft	1.1, 1.4, 1.4 i, 1.6 i, 1.8 D, 1.8 i, 1.9 D, 1.9 i	F8-5356	D1=72; D219; L=172
Engine Mounting	1.8 D, 1.8 i 16V, 1.9 D, 1.9 TD, 2.0, 2.0 i, 2.0 i 16V	F8-5357	
Engine Mounting	1.9 i	F8-5357	
Engine Mounting	1.6 i, 1.8 i	F8-5358	
Mounting, axle beam	1.1, 1.4, 1.4 i, 1.6 i, 1.8 D, 1.8 i, 1.8 i 16V, 1.9 D, 1.9 i, 1.9 TD, 2.0 i, 2.0 i 16V	F8-5363	
Engine Mounting	1.4 i	F8-5375	H=34; d=12; D=30
Top Strut Mounting	1.1, 1.4, 1.4 i, 1.6 i, 1.8 D, 1.8 i, 1.8 i 16V, 1.9 D, 1.9 i, 1.9 TD, 2.0 i, 2.0 i 16V	F8-5516	
Top Strut Mounting	1.1, 1.4, 1.4 i, 1.6 i, 1.8 D, 1.8 i, 1.8 i 16V, 1.9 D, 1.9 i, 1.9 TD, 2.0 i, 2.0 i 16V	F8-5517	
Engine Mounting	1.8 D, 1.8 i, 1.8 i 16V, 1.9 D, 1.9 i, 1.9 TD, 2.0 i, 2.0 i 16V	F8-5555	
Engine Mounting	1.6 i, 1.8 i, 1.9 i	F8-5556	
Engine Mounting	1.1, 1.6 i, 1.8 D, 1.8 i, 1.8 i 16V, 1.9 D, 1.9 i, 1.9 TD, 2.0 i, 2.0 i 16V	F8-5568	
Engine Mounting	1.4	Aluminium;  TU3M	F8-5568
Engine Mounting	1.4 i	Aluminium;  TU3JP, TU3M	F8-5568
Top Strut Mounting	2.0 i, 2.0 i 16V	ch. → O6579;	F8-5614
Belt Pulley, crankshaft	1.8 D, 1.9 D, 1.9 DT, 1.9 TD	Number of Ribs: 6	F8-5643
Rubber Buffer, suspension	1.6 i, 1.8 D, 1.8 i, 1.8 i 16V, 1.9 D		F8-6064
Stabiliser Mounting	1.1, 1.1, 1.4, 1.4 D, 1.4 i, 1.6 i, 1.8 D, 1.8 i, 1.8 i 16V, 1.9 D, 1.9 i, 1.9 TD, 2.0, 2.0 i, 2.0 i 16V		F8-6129
Engine Mounting	1.6 i, 1.8 D, 1.8 i, 1.8 i 16V, 1.9 D, 1.9 i, 1.9 TD		F8-6236
Engine Mounting	1.8 D, 1.8 i 16V, 1.9 D, 1.9 i, 1.9 TD		F8-6237
Repair Kit, wheel suspension	All Models		F8-6272
Top Strut Mounting	1.1, 1.4, 1.4 i, 1.6 i, 1.8 D, 1.8 i, 1.8 i 16V, 1.9 D, 1.9 i, 1.9 TD		F8-6296

<b>F8-5213</b>	<b>F8-5248</b>	<b>F8-5347</b>	<b>F8-5351</b>	<b>F8-5352</b>	<b>F8-5355</b>	<b>F8-5356</b>
Ref.Nr.: 5094.65	Ref.Nr.: 3523.59	Ref.Nr.: 96104506	Ref.Nr.: 513170	Ref.Nr.: 513169	Ref.Nr.: 3520.H5S1	Ref.Nr.: 328769
<b>F8-5357</b>	<b>F8-5358</b>	<b>F8-5363</b>	<b>F8-5375</b>	<b>F8-5516</b>	<b>F8-5517</b>	<b>F8-5555</b>
Ref.Nr.: 1844.47	Ref.Nr.: 184373	Ref.Nr.: 5131.71	Ref.Nr.: 180906	Ref.Nr.: 503824	Ref.Nr.: 5038.23	Ref.Nr.: 97521102
<b>F8-5556</b>	<b>F8-5568</b>	<b>F8-5614</b>	<b>F8-5643</b>	<b>F8-6064</b>	<b>F8-6129</b>	<b>F8-6236</b>
Ref.Nr.: 1843.95	Ref.Nr.: 184425	Ref.Nr.: 96159157	Ref.Nr.: 96089 38980	Ref.Nr.: 5033.26	Ref.Nr.: 509466	Ref.Nr.: 1809.21

**Article Description****Article Nr.****Fitting Position****ZX (N2) 03/1991 → 10/1997**

Top Strut Mounting	1.1, 1.4, 1.6 i, 1.8 D, 1.8 i, 1.8 i 16V, 1.9 D, 1.9 i, 1.9 TD, 2.0 i		<b>F8-6297</b>		
Engine Mounting	1.1, 1.1, 1.4 D		<b>F8-6487</b>		
Engine Mounting	1.4 i	TU3JP, TU3M	<b>F8-6487</b>		
Engine Mounting	1.6	XU5JP	<b>F8-6500</b>		
Engine Mounting	1.6 i	XU5JP, XU5M	<b>F8-6500</b>		
Engine Mounting	1.8, 1.8 D, 1.8 i, 1.8 i 16V, 1.9 D, 1.9 TD, 2.0, 2.0 i 16V		<b>F8-6500</b>		
Engine Mounting	1.9 D	XUD9A	<b>F8-6500</b>		
Engine Mounting	1.9 i	XU9JA	<b>F8-6500</b>		
Engine Mounting	2.0 i	XU10J2	<b>F8-6500</b>		
Mounting, automatic transmission	1.1, 1.1, 1.4 D		<b>F8-6505</b>		
Mounting, automatic transmission	1.4	Aluminium;  TU3M	<b>F8-6505</b>		
Mounting, automatic transmission	1.4 i	TU3JP	<b>F8-6505</b>		
Belt Pulley, crankshaft	1.8 i 16V	03/1997 →; Number of Ribs: 6	<b>F8-7083</b>		Belt Pulley Ø [mm]=127; Mounting points diam.[mm]=30; W=38
Belt Pulley, crankshaft	2.0 i 16V	Number of Ribs: 6	<b>F8-7083</b>		Belt Pulley Ø [mm]=127; Mounting points diam.[mm]=30; W=38
Belt Pulley, crankshaft	1.8 i, 2.0 i	09/1992 →; Number of Ribs: 6	<b>F8-7084</b>		Belt Pulley Ø [mm]=127; Mounting points diam.[mm]=30; W=45
Repair Kit, wheel suspension	All Models		<b>G8-272</b>		
Bellow, steering	1.1, 1.1, 1.4, 1.4 D, 1.4 i, 1.6, 1.6 i, 1.8, 1.8 D, 1.8 i, 1.8 i 16V, 1.9, 1.9 D, 1.9 DT, 1.9 i, 1.9 TD, 2.0, 2.0 i, 2.0 i 16V	with clamps;	<b>LM-10004S</b>		d1=10; d2=40; L [mm]=175
Bellow, steering	1.1, 1.1, 1.4, 1.4 D, 1.4 i, 1.6, 1.6 i, 1.8, 1.8 D, 1.8 i, 1.8 i 16V, 1.9, 1.9 D, 1.9 DT, 1.9 i, 1.9 TD, 2.0, 2.0 i, 2.0 i 16V	with clamps;	<b>LM-10004S</b>		d1=10; d2=40; L [mm]=175
Bellow, steering	1.1, 1.1, 1.4 D, 1.4 i, 1.6 i, 1.8, 1.8 D, 1.8 i, 1.8 i 16V, 1.9 D, 1.9 i, 1.9 TD, 2.0, 2.0 i, 2.0 i 16V	with clamps	<b>LM-10039S</b>		d1=40; d2=40; L [mm]=115

**ZX Estate (N2) 10/1993 → 02/1998**

Dust Cover Kit, shock absorber	All Models		<b>AK-735010</b>		
Anti-Friction Bearing	1.4 i, 1.8 D, 1.8 i, 1.8 i 16V, 1.9 D, 1.9 TD		<b>F8-3012</b>		H=20; d=66; D=100
Anti-Friction Bearing	1.6 i	XU5JP	<b>F8-3012</b>		H=20; d=66; D=100
Stabiliser Mounting	All Models		<b>F8-5213</b>		d=21
Control Arm-/Trailing Arm Bush	All Models		<b>F8-5248</b>		

<b>AK-735010</b>	<b>F8-3012</b>	<b>F8-5213</b>	<b>F8-5248</b>	<b>F8-5347</b>	<b>F8-6297</b>	<b>F8-6487</b>
Ref.Nr.:	Ref.Nr.: 503527	Ref.Nr.: 5094.65	Ref.Nr.: 3523.59	Ref.Nr.: 96104506	Ref.Nr.: 503527	Ref.Nr.: 184472
<b>F8-6500</b>	<b>F8-6505</b>	<b>F8-7083</b>	<b>F8-7084</b>	<b>G8-272</b>	<b>LM-10004S</b>	<b>LM-10039S</b>
Ref.Nr.: 1844.36	Ref.Nr.: 1844.51	Ref.Nr.: 0515.K6	Ref.Nr.: 0515.H6	Ref.Nr.: 5132.49	Ref.Nr.: 7910030073	Ref.Nr.: 4066.22

Article Description



Article Nr.

Fitting Position



<b>ZX Estate (N2)</b>				<b>10/1993 → 02/1998</b>	
Engine Mounting	1.4 i		<b>F8-5347</b>		
Mounting, axle beam	1.6 i, 1.8 i, 1.8 i 16V, 1.9 D, 1.9 TD		<b>F8-5351</b>		
Mounting, axle beam	All Models		<b>F8-5352</b>		
Control Arm-/Trailing Arm Bush	All Models		<b>F8-5355</b>		
Bellow, driveshaft	1.4 i	Transmission Type: MA	<b>F8-5356</b>		D1=72; D219; L=172
Bellow, driveshaft	1.6 i, 1.8 i, 1.9 D, 1.9 TD	Transmission Type: BE3	<b>F8-5356</b>		D1=72; D219; L=172
Engine Mounting	1.8 D, 1.8 i 16V, 1.9 D, 1.9 TD		<b>F8-5357</b>		
Engine Mounting	1.6 i	XU5JP	<b>F8-5358</b>		
Engine Mounting	1.8 i		<b>F8-5358</b>		
Mounting, axle beam	All Models		<b>F8-5363</b>		
Engine Mounting	1.4 i		<b>F8-5375</b>		H=34; d=12; D=30
Top Strut Mounting	All Models		<b>F8-5516</b>		
Top Strut Mounting	All Models		<b>F8-5517</b>		
Engine Mounting	1.6 i, 1.8 i		<b>F8-5556</b>		
Engine Mounting	1.4 i	Aluminium;  TU3JP, TU3M	<b>F8-5568</b>		
Engine Mounting	1.6 i, 1.8 D, 1.8 i, 1.8 i 16V, 1.9 D, 1.9 TD		<b>F8-5568</b>		
Belt Pulley, crankshaft	1.8 D, 1.9 D, 1.9 TD	Number of Ribs: 6	<b>F8-5643</b>		Belt Pulley Ø [mm]=156; W=44
Stabiliser Mounting	All Models		<b>F8-6129</b>		d=19
Engine Mounting	1.6 i, 1.8 D, 1.8 i, 1.8 i 16V, 1.9 TD		<b>F8-6236</b>		H1=53; H2=40; d=10; D=70
Engine Mounting	1.8 D, 1.8 i 16V, 1.9 D, 1.9 TD		<b>F8-6237</b>		
Repair Kit, wheel suspension	All Models		<b>F8-6272</b>		
Top Strut Mounting	All Models		<b>F8-6296</b>		
Top Strut Mounting	All Models		<b>F8-6297</b>		
Engine Mounting	1.4 i		<b>F8-6487</b>		
Engine Mounting	1.6 i	XU5JP	<b>F8-6500</b>		
Engine Mounting	1.8 D, 1.8 i 16V, 1.9 D, 1.9 TD		<b>F8-6500</b>		
Engine Mounting	1.8 i	XU7JP	<b>F8-6500</b>		
Engine Mounting	1.9 D	XUD9A	<b>F8-6500</b>		
Mounting, automatic transmission	1.4 i	Aluminium;  TU3JP, TU3M	<b>F8-6505</b>		
Belt Pulley, crankshaft	1.8 i 16V	Number of Ribs: 6	<b>F8-7083</b>		Belt Pulley Ø [mm]=127; Mounting points diam.[mm]=30; W=38
Belt Pulley, crankshaft	1.8 i	07/1995 →; Number of Ribs: 6	<b>F8-7084</b>		Belt Pulley Ø [mm]=127; Mounting points diam.[mm]=30; W=45

<b>F8-5347</b>	<b>F8-5351</b>	<b>F8-5352</b>	<b>F8-5355</b>	<b>F8-5356</b>	<b>F8-5357</b>	<b>F8-5358</b>
Ref.Nr.: 96104506	Ref.Nr.: 513170	Ref.Nr.: 513169	Ref.Nr.: 3520.H5S1	Ref.Nr.: 328769	Ref.Nr.: 1844.47	Ref.Nr.: 184373
<b>F8-5363</b>	<b>F8-5375</b>	<b>F8-5516</b>	<b>F8-5517</b>	<b>F8-5556</b>	<b>F8-5568</b>	<b>F8-5643</b>
Ref.Nr.: 5131.71	Ref.Nr.: 180906	Ref.Nr.: 503824	Ref.Nr.: 5038.23	Ref.Nr.: 1843.95	Ref.Nr.: 184425	Ref.Nr.: 96089 38980
<b>F8-6129</b>	<b>F8-6236</b>	<b>F8-6237</b>	<b>F8-6272</b>	<b>F8-6296</b>	<b>F8-6297</b>	<b>F8-6487</b>
Ref.Nr.: 509466	Ref.Nr.: 1809.21	Ref.Nr.: 1809.22	Ref.Nr.: 9556384280	Ref.Nr.: 503824	Ref.Nr.: 503527	Ref.Nr.: 184472

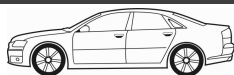
**Article Description****Article Nr.****Fitting Position**

<b>ZX Estate (N2)</b>			<b>10/1993 → 02/1998</b>		
Belt Pulley, crankshaft	1.8 i 16V	Number of Ribs: 6	<b>F8-7084</b>		Belt Pulley Ø [mm]=127; Mounting points diam.[mm]=30; W=45
Repair Kit, wheel suspension	All Models		<b>G8-272</b>		
Bellow, steering	1.4 i, 1.6 i, 1.8 D, 1.8 i, 1.8 i 16V, 1.9 D, 1.9 TD	with clamps;	<b>LM-10004S</b>		d1=10; d2=40; L [mm]=175
Bellow, steering	1.4 i, 1.6 i, 1.8 D, 1.8 i, 1.8 i 16V, 1.9 D, 1.9 TD	with clamps;	<b>LM-10004S</b>		d1=10; d2=40; L [mm]=175
Bellow, steering	All Models	with clamps	<b>LM-10039S</b>		d1=40; d2=40; L [mm]=115
<b>BERLINGO Platform/Chassis (B9)</b>			<b>04/2008 →</b>		
Anti-Friction Bearing	1.6 HDi 90		<b>F8-3012</b>		H=20; d=66; D=100
Top Strut Mounting	1.6 HDi 90		<b>F8-6058</b>		
Repair Kit, wheel suspension	1.6 HDi 90		<b>F8-6276</b>		
Top Strut Mounting	1.6 HDi 90		<b>F8-6302</b>		
Repair Kit, wheel suspension	1.6 HDi 90		<b>G8-276-5017</b>		H=197; d=34; D=50,17
Repair Kit, wheel suspension	1.6 HDi 90		<b>G8-276-5020</b>		H=197; d=34; D=50,2

<b>F8-3012</b>	<b>F8-6058</b>	<b>F8-6276</b>	<b>F8-6302</b>	<b>F8-7084</b>	<b>G8-272</b>	<b>G8-276-5017</b>
Ref.Nr.: 503527	Ref.Nr.: 5038.F7	Ref.Nr.: 9612314280	Ref.Nr.: 503885	Ref.Nr.: 0515.H6	Ref.Nr.: 5132.49	Ref.Nr.: 5132.73
<b>G8-276-5020</b>	<b>LM-10004S</b>	<b>LM-10039S</b>				
Ref.Nr.: 514851	Ref.Nr.: 7910030073	Ref.Nr.: 4066.22				

**Article Description**

**Article Nr.**
**Fitting Position**

<b>DOKKER</b>			<b>11/2012 →</b>		
Alternator Freewheel Clutch	1.5 dCi		<b>F5-1061</b>		
Alternator Freewheel Clutch	1.2 TCe		<b>F5-1110</b>		
Alternator Freewheel Clutch	1.5 dCi, 1.6 16V		<b>F5-1122</b>		
Alternator Freewheel Clutch	1.2 TCe		<b>F5-1129</b>		
<b>DOKKER Express</b>			<b>12/2012 →</b>		
Alternator Freewheel Clutch	1.5 dCi		<b>F5-1061</b>		
Alternator Freewheel Clutch	1.5 dCi		<b>F5-1122</b>		
<b>DUSTER</b>			<b>04/2010 →</b>		
Alternator Freewheel Clutch	1.5 dCi, 1.5 dCi 4x4, 1.6 16V LPG		<b>F5-1061</b>		
Alternator Freewheel Clutch	1.5 dCi, 1.5 dCi 4x4, 1.6 16V, 1.6 16V 4x4, 1.6 16V Flexifuel, 1.6 16V LPG		<b>F5-1122</b>		
Anti-Friction Bearing	1.2 Tce, 1.5 dCi, 1.5 dCi 4x4, 1.6 16V, 1.6 16V 4x4, 1.6 16V Flexifuel, 1.6 16V LPG		<b>F8-3032</b>		H=9; d1=16; d2=27; D=56
Top Strut Mounting	1.2 Tce, 1.5 dCi, 1.5 dCi 4x4, 1.6 16V, 1.6 16V 4x4, 1.6 16V Flexifuel, 1.6 16V LPG		<b>F8-6339</b>		
Top Strut Mounting	1.2 Tce, 1.5 dCi, 1.5 dCi 4x4, 1.6 16V, 1.6 16V 4x4, 1.6 16V Flexifuel, 1.6 16V LPG		<b>F8-6596</b>		
Spring Cap	1.2 Tce, 1.5 dCi, 1.5 dCi 4x4, 1.6 16V, 1.6 16V 4x4, 1.6 16V Flexifuel, 1.6 16V LPG	for OE: 6001548403, 8200876298	<b>F8-6710</b>		
Spring Cap	1.2 Tce, 1.5 dCi, 1.5 dCi 4x4, 1.6 16V, 1.6 16V 4x4, 1.6 16V Flexifuel, 1.6 16V LPG		<b>F8-7450</b>		
Belt Pulley, crankshaft	1.5 dCi 4x4		<b>F8-7646</b>		
Belt Pulley, crankshaft	1.5 dCi 4x4		<b>F8-7655</b>		
Rubber Buffer, suspension	1.2 Tce, 1.5 dCi, 1.5 dCi 4x4, 1.6 16V, 1.6 16V 4x4, 1.6 16V Flexifuel, 1.6 16V LPG		<b>F8-7900</b>		
Control Arm-/Trailing Arm Bush	1.5 dCi 4x4, 1.6 16V 4x4		<b>F8-8070</b>		
					D=30, 35; Thick. [mm]=40
<b>LOGGY</b>			<b>03/2012 →</b>		
Alternator Freewheel Clutch	1.5 dCi		<b>F5-1061</b>		
Alternator Freewheel Clutch	1.2 TCe		<b>F5-1110</b>		
Alternator Freewheel Clutch	1.5 dCi, 1.6		<b>F5-1122</b>		
Alternator Freewheel Clutch	1.2 TCe		<b>F5-1129</b>		
Alternator Freewheel Clutch	1.5 dCi		<b>F5-1130</b>		
<b>LOGAN (LS_)</b>			<b>09/2004 →</b>		
Alternator Freewheel Clutch	1.2 16V LPG	K7J	<b>F5-1029</b>		
Alternator Freewheel Clutch	1.4 , 1.6 , 1.6 Bifuel, 1.6 MPI 85		<b>F5-1029</b>		
Alternator Freewheel Clutch	1.4 , 1.4 MPI LPG , 1.5 dCi , 1.6 , 1.6 16V Flexifuel		<b>F5-1061</b>		
Alternator Freewheel Clutch	1.6 16V , 1.6 16V Flexifuel		<b>F5-1122</b>		

<b>F5-1029</b>	<b>F5-1061</b>	<b>F5-1110</b>	<b>F5-1122</b>	<b>F5-1129</b>	<b>F5-1130</b>	<b>F8-3032</b>
Ref.Nr.: 7700110616	Ref.Nr.: 7700110616	Ref.Nr.: 8200489514	Ref.Nr.:	Ref.Nr.: 23151-JG71B	Ref.Nr.: 23151-3VD1A	Ref.Nr.: 8200651172
<b>F8-6339</b>	<b>F8-6596</b>	<b>F8-6710</b>	<b>F8-7450</b>	<b>F8-7646</b>	<b>F8-7655</b>	<b>F8-7900</b>
Ref.Nr.: 8200307941	Ref.Nr.: 6001547499	Ref.Nr.: 6001548403	Ref.Nr.: 7700415728	Ref.Nr.: 8200395313	Ref.Nr.: 8200687605	Ref.Nr.: 6001548402
<b>F8-8070</b>						
Ref.Nr.: 82 00 839 121						

**Article Description****Article Nr.****Fitting Position**

<b>LOGAN (LS_)</b>			<b>09/2004 →</b>		
Anti-Friction Bearing	1.2 16V LPG, 1.4, 1.5 dCi, 1.6, 1.6 16V, 1.6 Bifuel		<b>F8-3032</b>		H=9; d1=16; d2=27; D=56
Belt Pulley, crankshaft	1.5 dCi		<b>F8-5657</b>		
Top Strut Mounting	All Models		<b>F8-6339</b>		
Top Strut Mounting	1.2 16V, 1.2 16V LPG, 1.4, 1.4 MPI LPG, 1.5 dCi, 1.6, 1.6 16V, 1.6 Bifuel, 1.6 MPI 85		<b>F8-6596</b>		
Mounting, axle beam	1.4, 1.5 dCi, 1.6, 1.6 16V		<b>F8-6597</b>		
Engine Mounting	1.4, 1.5 dCi, 1.6, 1.6 16V		<b>F8-6599</b>		L=125
Engine Mounting	1.4, 1.5 dCi, 1.6, 1.6 16V		<b>F8-6600</b>		
Stabiliser Mounting	1.4, 1.5 dCi, 1.6, 1.6 16V		<b>F8-6601</b>		d=23
Spring Cap	All Models	for OE: 6001548403, 8200876298	<b>F8-6710</b>		
Engine Mounting	1.2 16V LPG, 1.4, 1.5 dCi, 1.6, 1.6 16V, 1.6 Bifuel, 1.6 MPI 85		<b>F8-6711</b>		
Spring Cap	All Models		<b>F8-7450</b>		
Belt Pulley, crankshaft	1.6 16V		<b>F8-7646</b>		
Engine Mounting	1.5 dCi		<b>F8-7746</b>		
Engine Mounting	1.5 dCi		<b>F8-7746</b>		
Rubber Buffer, suspension	All Models		<b>F8-7900</b>		
Control Arm-/Trailing Arm Bush	1.2 16V, 1.2 16V LPG, 1.4, 1.5 dCi, 1.6, 1.6 16V, 1.6 16V Flexifuel, 1.6 Bifuel, 1.6 MPI 85		<b>F8-7977</b>		
Engine Mounting	1.2 16V, 1.2 16V LPG, 1.4, 1.4 MPI LPG, 1.5 dCi, 1.6, 1.6 16V, 1.6 Bifuel, 1.6 MPI 85		<b>F8-8157</b>		
Bellow, steering	1.4, 1.5 dCi, 1.6, 1.6 16V	with clamps	<b>LM-10032S</b>		d1=9.5; d2=42; L [mm]=165
<b>LOGAN EXPRESS (FS_)</b>			<b>03/2009 →</b>		
Alternator Freewheel Clutch	1.4, 1.6, 1.6 MPI 85		<b>F5-1029</b>		
Alternator Freewheel Clutch	1.4, 1.5 dCi, 1.6		<b>F5-1061</b>		
Alternator Freewheel Clutch	1.4		<b>F5-1129</b>		
Anti-Friction Bearing	1.4, 1.5 dCi, 1.6		<b>F8-3032</b>		H=9; d1=16; d2=27; D=56
Belt Pulley, crankshaft	1.5 dCi		<b>F8-5657</b>		
Top Strut Mounting	All Models		<b>F8-6596</b>		
Engine Mounting	1.4, 1.6, 1.6 MPI 85		<b>F8-6711</b>		
Rubber Buffer, suspension	All Models		<b>F8-7900</b>		
Control Arm-/Trailing Arm Bush	All Models		<b>F8-7977</b>		
Engine Mounting	1.5 dCi		<b>F8-8157</b>		
Bellow, steering	1.4, 1.5 dCi, 1.6	with clamps	<b>LM-10032S</b>		d1=9.5; d2=42; L [mm]=165
<b>LOGAN MCV (KS_)</b>			<b>02/2007 →</b>		
Alternator Freewheel Clutch	1.4, 1.6, 1.6 Bifuel, 1.6 MPI 85		<b>F5-1029</b>		

<b>F5-1029</b>	<b>F5-1061</b>	<b>F5-1129</b>	<b>F8-3032</b>	<b>F8-5657</b>	<b>F8-6339</b>	<b>F8-6596</b>
Ref.Nr.: 7700110616	Ref.Nr.: 7700110616	Ref.Nr.: 23151-JG71B	Ref.Nr.: 8200651172	Ref.Nr.: 8200185800	Ref.Nr.: 8200307941	Ref.Nr.: 6001547499
<b>F8-6597</b>	<b>F8-6599</b>	<b>F8-6600</b>	<b>F8-6601</b>	<b>F8-6710</b>	<b>F8-6711</b>	<b>F8-7450</b>
Ref.Nr.: 6001549989	Ref.Nr.: 8200297939	Ref.Nr.: 8200395661	Ref.Nr.: 6001547140	Ref.Nr.: 6001548403	Ref.Nr.: 112107695R	Ref.Nr.: 7700415728
<b>F8-7646</b>	<b>F8-7746</b>	<b>F8-7900</b>	<b>F8-7977</b>	<b>F8-8157</b>	<b>LM-10032S</b>	
Ref.Nr.: 8200395313	Ref.Nr.: 8200042456	Ref.Nr.: 6001548402	Ref.Nr.: 6040002245	Ref.Nr.: 8200575641	Ref.Nr.: 7701470361	

Article Description



Article Nr.

Fitting Position



<b>LOGAN MCV (KS_)</b>			<b>02/2007 →</b>		
Alternator Freewheel Clutch	1.4, 1.5 dCi , 1.6, 1.6 16V, 1.6 16V Flexifuel, 1.6 Bifuel		<b>F5-1061</b>		
Alternator Freewheel Clutch	1.6 16V, 1.6 16V Flexifuel		<b>F5-1122</b>		
Anti-Friction Bearing	1.4, 1.5 dCi , 1.6, 1.6 16V, 1.6 16V Flexifuel, 1.6 Bifuel		<b>F8-3032</b>		H=9; d1=16; d2=27; D=56
Belt Pulley, crankshaft	1.5 dCi		<b>F8-5657</b>		
Top Strut Mounting	All Models		<b>F8-6339</b>		
Top Strut Mounting	All Models		<b>F8-6596</b>		
Mounting, axle beam	1.4, 1.5 dCi , 1.6, 1.6 16V		<b>F8-6597</b>		
Engine Mounting	1.4, 1.5 dCi , 1.6, 1.6 16V		<b>F8-6599</b>		L=125
Engine Mounting	1.4, 1.5 dCi , 1.6, 1.6 16V		<b>F8-6600</b>		
Stabiliser Mounting	1.4, 1.5 dCi , 1.6, 1.6 16V		<b>F8-6601</b>		d=23
Spring Cap	1.4, 1.5 dCi , 1.6, 1.6 16V	for OE: 6001548403, 8200876298	<b>F8-6710</b>		
Engine Mounting	1.4, 1.5 dCi , 1.6, 1.6 16V, 1.6 Bifuel, 1.6 MPI 85		<b>F8-6711</b>		
Belt Pulley, crankshaft	1.6 16V, 1.6 16V Flexifuel		<b>F8-7646</b>		
Engine Mounting	1.5 dCi		<b>F8-7746</b>		
Rubber Buffer, suspension	All Models		<b>F8-7900</b>		
Control Arm-/Trailing Arm Bush	All Models		<b>F8-7977</b>		
Engine Mounting	1.4, 1.5 dCi , 1.6, 1.6 16V, 1.6 16V Flexifuel, 1.6 Bifuel, 1.6 MPI 85		<b>F8-8157</b>		
Bellow, steering	1.4, 1.5 dCi , 1.6, 1.6 16V	with clamps	<b>LM-10032S</b>		d1=9.5; d2=42; L [mm]=165
<b>LOGAN Pickup (US_)</b>			<b>03/2008 →</b>		
Alternator Freewheel Clutch	1.4, 1.6, 1.6 MPI 85		<b>F5-1029</b>		
Alternator Freewheel Clutch	1.4, 1.5 dCi , 1.6		<b>F5-1061</b>		
Anti-Friction Bearing	1.4, 1.5 dCi , 1.6		<b>F8-3032</b>		H=9; d1=16; d2=27; D=56
Belt Pulley, crankshaft	1.5 dCi		<b>F8-5657</b>		
Top Strut Mounting	All Models		<b>F8-6339</b>		
Top Strut Mounting	1.4, 1.5 dCi , 1.6, 1.6 MPI 85		<b>F8-6596</b>		
Engine Mounting	1.5 dCi , 1.6		<b>F8-6599</b>		L=125
Engine Mounting	1.6, 1.6 MPI 85		<b>F8-6711</b>		
Rubber Buffer, suspension	All Models		<b>F8-7900</b>		
Control Arm-/Trailing Arm Bush	1.4, 1.5 dCi , 1.6, 1.6 MPI 85		<b>F8-7977</b>		
Engine Mounting	1.5 dCi		<b>F8-8157</b>		
Bellow, steering	1.5 dCi , 1.6	with clamps	<b>LM-10032S</b>		d1=9.5; d2=42; L [mm]=165
<b>LOGAN II</b>			<b>10/2012 →</b>		
Alternator Freewheel Clutch	1.5 dCi		<b>F5-1061</b>		



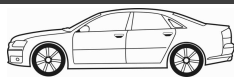

**Article Description****Article Nr.****Fitting Position**

<b>LOGAN II</b>			<b>10/2012 →</b>		
Alternator Freewheel Clutch	1.5 dCi		<b>F5-1122</b>		
Rubber Buffer, suspension	1.2, 1.2 LPG, 1.5 dCi, TCe 90		<b>F8-7900</b>		
<b>SANDERO</b>			<b>06/2008 →</b>		
Alternator Freewheel Clutch	1.4, 1.5 dCi, 1.6, 1.6 16V Bifuel		<b>F5-1061</b>		
Alternator Freewheel Clutch	1.6 16V Bifuel		<b>F5-1122</b>		
Anti-Friction Bearing	1.4, 1.5 dCi, 1.6		<b>F8-3032</b>		H=9; d1=16; d2=27; D=56
Belt Pulley, crankshaft	1.5 dCi		<b>F8-5657</b>		
Top Strut Mounting	1.2 16V, 1.2 16V LPG, 1.4, 1.4 MPI LPG, 1.5 dCi, 1.6, 1.6 16V, 1.6 16V Bifuel, 1.6 MPI 85		<b>F8-6339</b>		
Top Strut Mounting	1.2 16V, 1.2 16V LPG, 1.4, 1.4 MPI LPG, 1.5 dCi, 1.6, 1.6 16V Bifuel, 1.6 MPI 85		<b>F8-6596</b>		
Engine Mounting	1.2 16V, 1.4, 1.5 dCi, 1.6		<b>F8-6599</b>		L=125
Stabiliser Mounting	1.4, 1.5 dCi, 1.6		<b>F8-6601</b>		d=23
Spring Cap	1.2 16V, 1.2 16V LPG, 1.4, 1.4 MPI LPG, 1.5 dCi, 1.6, 1.6 16V, 1.6 16V Bifuel, 1.6 MPI 85	for OE: 6001548403, 8200876298	<b>F8-6710</b>		
Engine Mounting	1.4, 1.4 MPI LPG, 1.6, 1.6 16V Bifuel, 1.6 MPI 85		<b>F8-6711</b>		
Spring Cap	1.2 16V, 1.2 16V LPG, 1.4, 1.4 MPI LPG, 1.5 dCi, 1.6, 1.6 16V, 1.6 16V Bifuel, 1.6 MPI 85		<b>F8-7450</b>		
Belt Pulley, crankshaft	1.5 dCi	Number of Ribs: 5; Parameter: 6PK	<b>F8-7732</b>		
Rubber Buffer, suspension	1.2 16V, 1.2 16V LPG, 1.4, 1.4 MPI LPG, 1.5 dCi, 1.6, 1.6 16V, 1.6 16V Bifuel, 1.6 MPI 85		<b>F8-7900</b>		
Control Arm-/Trailing Arm Bush	1.2 16V, 1.4, 1.4 MPI LPG, 1.5 dCi, 1.6, 1.6 16V, 1.6 16V Bifuel, 1.6 MPI 85		<b>F8-7977</b>		
Engine Mounting	1.2 16V, 1.2 16V LPG, 1.4, 1.4 MPI LPG, 1.5 dCi, 1.6, 1.6 16V, 1.6 16V Bifuel, 1.6 MPI 85		<b>F8-8157</b>		
Bellow, steering	1.2 16V, 1.4, 1.5 dCi, 1.6	with clamps	<b>LM-10032S</b>		d1=9.5; d2=42; L [mm]=165
<b>SANDERO II</b>			<b>10/2012 →</b>		
Alternator Freewheel Clutch	1.5 dCi		<b>F5-1061</b>		
Alternator Freewheel Clutch	1.5 dCi		<b>F5-1122</b>		
Rubber Buffer, suspension	1.2, 1.2 LPG, 1.5 dCi, TCe 90		<b>F8-7900</b>		
<b>LOGAN MCV II</b>			<b>02/2013 →</b>		
Alternator Freewheel Clutch	1.5 dCi		<b>F5-1061</b>		
Alternator Freewheel Clutch	1.5 dCi		<b>F5-1122</b>		
Rubber Buffer, suspension	1.2, 1.2 LPG, 1.5 dCi, TCe 90		<b>F8-7900</b>		

<b>F5-1061</b>	<b>F5-1122</b>	<b>F8-3032</b>	<b>F8-5657</b>	<b>F8-6339</b>	<b>F8-6596</b>	<b>F8-6599</b>
Ref.Nr.: 7700110616	Ref.Nr.:	Ref.Nr.: 8200651172	Ref.Nr.: 8200185800	Ref.Nr.: 8200307941	Ref.Nr.: 6001547499	Ref.Nr.: 8200297939
<b>F8-6601</b>	<b>F8-6710</b>	<b>F8-6711</b>	<b>F8-7450</b>	<b>F8-7732</b>	<b>F8-7900</b>	<b>F8-7977</b>
Ref.Nr.: 6001547140	Ref.Nr.: 6001548403	Ref.Nr.: 112107695R	Ref.Nr.: 7700415728	Ref.Nr.: 8200477938	Ref.Nr.: 6001548402	Ref.Nr.: 6040002245
<b>F8-8157</b>	<b>LM-10032S</b>					
Ref.Nr.: 8200575641	Ref.Nr.: 7701470361					

Article Description



Article Nr.

Fitting Position



<b>ESPERO (KLEJ)</b>			<b>10/1991 → 09/1999</b>	
Dust Cover Kit, shock absorber	1.5 16V, 1.8, 2.0		<b>AK-735003</b>	
Top Strut Mounting	1.5, 1.5 16V, 1.8, 2.0	for OE: 90184756; ☼	<b>F8-3059</b>	d1=14; d2=37; D=78; T [mm]=132
Mounting, axle beam	1.5, 1.5 16V, 1.8, 2.0		<b>F8-3060</b>	H=75; d=12; D1=49; D2=57
Mounting, axle beam	1.5, 1.5 16V, 1.8, 2.0		<b>F8-4102</b>	H=74; d=12; D1=60; D2=66
Mounting, stabilizer coupling rod	1.5 16V, 1.8, 2.0		<b>F8-5333</b>	d=8.5; D=30
Top Strut Mounting	1.5, 1.5 16V, 1.8, 2.0	for OE: 90184755; ☼	<b>F8-5589</b>	
Rubber Buffer, suspension	1.5 16V, 1.8, 2.0		<b>F8-5710</b>	H=46
Engine Mounting	1.5, 1.5 16V, 1.8, 2.0		<b>F8-7121</b>	
Engine Mounting	1.5, 1.5 16V, 1.8, 2.0		<b>F8-7123</b>	
Control Arm-/Trailing Arm Bush	1.5, 1.5 16V, 1.8, 2.0		<b>G9-591</b>	H=59; d=14.5; D1=39; D2=44
Control Arm-/Trailing Arm Bush	1.5, 1.5 16V, 1.8, 2.0		<b>G9-592</b>	H=54; d=6; d1=6; d2=23
Bellow, steering	1.5, 1.5 16V, 1.8, 2.0	with clamps	<b>LM-10045S</b>	d1=42; d2=52; L [mm]=165
Bellow, steering	1.5, 1.5 16V, 1.8, 2.0		<b>M-822300</b>	
Bellow, steering	1.5 16V, 1.8, 2.0		<b>MK-822300</b>	H=165; d1=42; d2=52
Repair Kit, steering gear	1.5 16V, 1.8, 2.0		<b>MK-822300S</b>	
<b>KALOS (KLAS)</b>			<b>09/2002 → 12/2004</b>	
Dust Cover Kit, shock absorber	All Models		<b>AK-735095</b>	
Dust Cover Kit, shock absorber	All Models		<b>AK-735315</b>	
Dust Cover Kit, shock absorber	All Models		<b>AK-735316</b>	
Top Strut Mounting	1.2, 1.4, 1.4 16V		<b>F8-7369</b>	
Control Arm-/Trailing Arm Bush	All Models		<b>F8-8014</b>	H=46; d=12; D=60
Control Arm-/Trailing Arm Bush	All Models	ch.690152→	<b>F8-8015</b>	d=12; L=47; D=28
<b>KALOS Saloon (KLAS)</b>			<b>11/2002 → 12/2004</b>	
Dust Cover Kit, shock absorber	All Models		<b>AK-735095</b>	
Control Arm-/Trailing Arm Bush	All Models		<b>F8-8014</b>	H=46; d=12; D=60
Control Arm-/Trailing Arm Bush	All Models	ch.690152→	<b>F8-8015</b>	d=12; L=47; D=28
<b>LACETTI Hatchback (KLAN)</b>			<b>02/2004 →</b>	
Control Arm-/Trailing Arm Bush	All Models		<b>F8-7937</b>	
Control Arm-/Trailing Arm Bush	1.8		<b>F8-8219</b>	H=60; d=12; D=39



**Article Description****Article Nr.****Fitting Position**

<b>LANOS (KLAT)</b>			<b>05/1997 → 06/1999</b>		
Dust Cover Kit, shock absorber	1.4, 1.5, 1.6 16V		<b>AK-735003</b>		
Mounting, axle beam	1.4, 1.5, 1.6 16V		<b>F8-3060</b>		H=75; d=12; D1=49; D2=57
Mounting, stabilizer coupling rod	1.4, 1.5, 1.6 16V		<b>F8-5333</b>		d=8.5; D=30
Rubber Buffer, suspension	1.6 16V		<b>F8-5710</b>		H=46
Top Strut Mounting	1.4, 1.5, 1.6 16V	10/1999 →;	<b>F8-7117</b>		
Top Strut Mounting	1.4, 1.5, 1.6 16V	10/1999 →;	<b>F8-7118</b>		
Engine Mounting	1.4, 1.5, 1.6 16V		<b>F8-7121</b>		
Engine Mounting	1.4, 1.5, 1.6 16V		<b>F8-7123</b>		
Top Strut Mounting	All Models		<b>F8-7368</b>		
Control Arm-/Trailing Arm Bush	1.4, 1.5, 1.6 16V		<b>G9-591</b>		H=59; d=14.5; D1=39; D2=44
Control Arm-/Trailing Arm Bush	1.4, 1.5, 1.6 16V		<b>G9-592</b>		H=54; d=6; d1=6; d2=23
<b>LANOS Saloon (KLAT)</b>			<b>05/1997 →</b>		
Dust Cover Kit, shock absorber	1.4, 1.5		<b>AK-735003</b>		
Mounting, axle beam	1.4, 1.5, 1.6 16V		<b>F8-3060</b>		H=75; d=12; D1=49; D2=57
Mounting, stabilizer coupling rod	1.4, 1.5, 1.6 16V		<b>F8-5333</b>		d=8.5; D=30
Rubber Buffer, suspension	1.6 16V		<b>F8-5710</b>		H=46
Top Strut Mounting	1.4, 1.5, 1.6 16V	10/1999 →;	<b>F8-7117</b>		
Top Strut Mounting	1.4, 1.5, 1.6 16V	10/1999 →;	<b>F8-7118</b>		
Engine Mounting	1.4, 1.5, 1.6 16V		<b>F8-7121</b>		
Engine Mounting	1.4, 1.5, 1.6 16V		<b>F8-7123</b>		
Top Strut Mounting	1.4, 1.5, 1.6 16V		<b>F8-7368</b>		
Control Arm-/Trailing Arm Bush	1.4, 1.5		<b>G9-591</b>		H=59; d=14.5; D1=39; D2=44
Control Arm-/Trailing Arm Bush	1.6 16V	ch.→447433	<b>G9-591</b>		H=59; d=14.5; D1=39; D2=44
Control Arm-/Trailing Arm Bush	1.4, 1.5, 1.6 16V		<b>G9-592</b>		H=54; d=6; d1=6; d2=23
<b>LEGANZA (KLAV)</b>			<b>06/1997 → 04/2004</b>		
Bellow, steering	1.8 CD, 2.0 16V, 2.2 16V	with clamps	<b>LM-10059S</b>		d1=13; d2=49; L [mm]=166
<b>MATIZ (KLYA)</b>			<b>09/1998 →</b>		
Dust Cover Kit, shock absorber	All Models		<b>AK-735003</b>		
Control Arm-/Trailing Arm Bush	All Models		<b>F8-6585</b>		
Stabiliser Mounting	0.8		<b>F8-7986</b>		

<b>AK-735003</b>	<b>F8-3060</b>	<b>F8-5333</b>	<b>F8-5710</b>	<b>F8-6585</b>	<b>F8-7117</b>	<b>F8-7118</b>
Ref.Nr.:	Ref.Nr.: 90189050	Ref.Nr.: 2875013	Ref.Nr.: 0344402	Ref.Nr.: 96 380 613	Ref.Nr.: 96444919	Ref.Nr.: 96444920
<b>F8-7121</b>	<b>F8-7123</b>	<b>F8-7368</b>	<b>F8-7986</b>	<b>F8-8013</b>	<b>G9-591</b>	<b>G9-592</b>
Ref.Nr.: 90250348	Ref.Nr.: 90250437	Ref.Nr.: 96225638	Ref.Nr.: 96380586	Ref.Nr.: 96322618	Ref.Nr.: 90193117	Ref.Nr.: 352335
<b>LM-10059S</b>						
Ref.Nr.: 520738						

Article Description



Article Nr.

Fitting Position



<b>MATIZ (KLYA)</b>				<b>09/1998 →</b>	
Stabiliser Mounting	All Models		<b>F8-8013</b>		d=21
<b>MUSSO (FJ)</b>				<b>01/1999 →</b>	
Control Arm-/Trailing Arm Bush	2.3		<b>F8-8187</b>		
<b>NEXIA (KLETN)</b>				<b>02/1995 → 08/1997</b>	
Dust Cover Kit, shock absorber	All Models		<b>AK-735003</b>		
Mounting, axle beam	All Models		<b>F8-3060</b>		H=75; d=12; D1=49; D2=57
Mounting, axle beam	All Models		<b>F8-4102</b>		H=74; d=12; D1=60; D2=66
Mounting, stabilizer coupling rod	All Models		<b>F8-5333</b>		d=8.5; D=30
Engine Mounting	All Models		<b>F8-7121</b>		
Engine Mounting	All Models		<b>F8-7123</b>		
Control Arm-/Trailing Arm Bush	All Models		<b>G9-591</b>		H=59; d=14.5; D1=39; D2=44
Control Arm-/Trailing Arm Bush	All Models		<b>G9-592</b>		H=54; d=6; d1=6; d2=23
Bellow, steering	All Models	with clamps	<b>LM-10045S</b>		d1=42; d2=52; L [mm]=165
Bellow, steering	All Models		<b>M-822300</b>		
Bellow, steering	All Models		<b>MK-822300</b>		H=165; d1=42; d2=52
Repair Kit, steering gear	All Models		<b>MK-822300S</b>		
<b>NEXIA Saloon (KLETN)</b>				<b>02/1995 → 08/1997</b>	
Dust Cover Kit, shock absorber	1.5, 1.5 16V		<b>AK-735003</b>		
Mounting, axle beam	1.5, 1.5 16V		<b>F8-3060</b>		H=75; d=12; D1=49; D2=57
Mounting, axle beam	1.5, 1.5 16V		<b>F8-4102</b>		H=74; d=12; D1=60; D2=66
Mounting, stabilizer coupling rod	1.5, 1.5 16V		<b>F8-5333</b>		d=8.5; D=30
Engine Mounting	1.5, 1.5 16V		<b>F8-7121</b>		
Engine Mounting	1.5, 1.5 16V		<b>F8-7123</b>		
Control Arm-/Trailing Arm Bush	1.5, 1.5 16V		<b>G9-591</b>		H=59; d=14.5; D1=39; D2=44
Control Arm-/Trailing Arm Bush	1.5, 1.5 16V		<b>G9-592</b>		H=54; d=6; d1=6; d2=23
Bellow, steering	1.5, 1.5 16V	with clamps	<b>LM-10045S</b>		d1=42; d2=52; L [mm]=165
Bellow, steering	1.5, 1.5 16V		<b>M-822300</b>		
Bellow, steering	1.5, 1.5 16V		<b>MK-822300</b>		H=165; d1=42; d2=52
Repair Kit, steering gear	1.5, 1.5 16V		<b>MK-822300S</b>		

<b>AK-735003</b>	<b>F8-3060</b>	<b>F8-4102</b>	<b>F8-5333</b>	<b>F8-7121</b>	<b>F8-7123</b>	<b>F8-8013</b>
Ref.Nr.:	Ref.Nr.: 90189050	Ref.Nr.: 90372559	Ref.Nr.: 2875013	Ref.Nr.: 90250348	Ref.Nr.: 90250437	Ref.Nr.: 96322618
<b>F8-8187</b>	<b>G9-591</b>	<b>G9-592</b>	<b>LM-10045S</b>	<b>M-822300</b>	<b>MK-822300</b>	<b>MK-822300S</b>
Ref.Nr.: 96308002	Ref.Nr.: 90193117	Ref.Nr.: 352335	Ref.Nr.: 26024585	Ref.Nr.: 90090811	Ref.Nr.: 90345195	Ref.Nr.: 902828

**Article Description****Article Nr.****Fitting Position**

<b>NUBIRA (KLAJ)</b>			<b>05/1997 → 07/2003</b>		
Rubber Buffer, suspension	1.6 16V, 2.0 16V		<b>F8-5710</b>		H=46
Control Arm-/Trailing Arm Bush	1.6 16V, 2.0 16V		<b>F8-8186</b>		
Control Arm-/Trailing Arm Bush	1.6 16V, 2.0 16V		<b>F8-8187</b>		
Bearing Bush, stabiliser	1.6, 1.6 16V, 2.0 16V, 2.0 CDX		<b>F8-8217</b>		d=17
Bearing Bush, stabiliser	1.6 16V, 2.0 16V		<b>F8-8218</b>		
Control Arm-/Trailing Arm Bush	1.6, 2.0 CDX		<b>F8-8219</b>		H=60; d=12; D=39
Bellow, steering	1.6 16V, 2.0 16V	with clamps	<b>LM-10059S</b>		d1=13; d2=49; L [mm]=166
<b>NUBIRA Saloon (KLAJ)</b>			<b>05/1997 →</b>		
Rubber Buffer, suspension	1.6 16V, 2.0 16V		<b>F8-5710</b>		H=46
Control Arm-/Trailing Arm Bush	1.6 16V, 2.0 16V		<b>F8-8186</b>		
Control Arm-/Trailing Arm Bush	1.6 16V, 2.0 16V		<b>F8-8187</b>		
Bearing Bush, stabiliser	1.6 16V, 2.0 16V		<b>F8-8217</b>		d=17
Bearing Bush, stabiliser	1.6 16V, 2.0 16V		<b>F8-8218</b>		
Control Arm-/Trailing Arm Bush	1.6 16V, 2.0 16V		<b>F8-8219</b>		H=60; d=12; D=39
Bellow, steering	1.6 16V, 2.0 16V	with clamps	<b>LM-10059S</b>		d1=13; d2=49; L [mm]=166
<b>NUBIRA Wagon (KLAJ)</b>			<b>05/1997 →</b>		
Rubber Buffer, suspension	1.6 16V, 2.0 16V		<b>F8-5710</b>		H=46
Control Arm-/Trailing Arm Bush	1.6 16V, 2.0 16V		<b>F8-8186</b>		
Control Arm-/Trailing Arm Bush	1.6 16V, 2.0 16V		<b>F8-8187</b>		
Bearing Bush, stabiliser	1.6 16V, 2.0 16V		<b>F8-8217</b>		d=17
Bearing Bush, stabiliser	1.6 16V, 2.0 16V		<b>F8-8218</b>		
Control Arm-/Trailing Arm Bush	1.6 16V, 2.0 16V		<b>F8-8219</b>		H=60; d=12; D=39
Bellow, steering	1.6 16V, 2.0 16V	with clamps	<b>LM-10059S</b>		d1=13; d2=49; L [mm]=166
<b>NUBIRA Saloon (KLAN)</b>			<b>07/2003 → 12/2004</b>		
Dust Cover Kit, shock absorber	1.6, 1.8		<b>AK-735317</b>		
Dust Cover Kit, shock absorber	1.6, 1.8		<b>AK-735318</b>		
Control Arm-/Trailing Arm Bush	All Models		<b>F8-7937</b>		
Control Arm-/Trailing Arm Bush	All Models		<b>F8-8219</b>		H=60; d=12; D=39

<b>AK-735317</b>	<b>AK-735318</b>	<b>F8-5710</b>	<b>F8-7937</b>	<b>F8-8186</b>	<b>F8-8187</b>	<b>F8-8217</b>
Ref.Nr.: 96300082	Ref.Nr.: 96403109	Ref.Nr.: 0344402	Ref.Nr.: 96391856	Ref.Nr.: 96298000	Ref.Nr.: 96308002	Ref.Nr.: 96311832
<b>F8-8218</b>	<b>F8-8219</b>	<b>LM-10059S</b>				
Ref.Nr.: 96297803	Ref.Nr.: 96378346	Ref.Nr.: 520738				

Article Description



Article Nr.











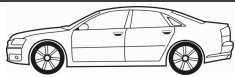













Fitting Position



<b>NUBIRA Wagon (KLAN)</b>			<b>07/2003 →</b>		
Dust Cover Kit, shock absorber	1.6, 1.8		<b>AK-735317</b>		
Dust Cover Kit, shock absorber	1.6, 1.8		<b>AK-735318</b>		
Control Arm-/Trailing Arm Bush	All Models		<b>F8-7937</b>		
Control Arm-/Trailing Arm Bush	1.6, 1.8		<b>F8-8219</b>		H=60; d=12; D=39
Bearing Bush, stabiliser	1.6		<b>F8-8221</b>		d=18
Bellow, steering	1.8	with clamps	<b>LM-10059S</b>		d1=13; d2=49; L [mm]=166
<b>TACUMA (KLAU)</b>			<b>09/2000 → 12/2004</b>		
Control Arm-/Trailing Arm Bush	1.6, 1.6 SX, 1.8, 2.0		<b>F8-8219</b>		H=60; d=12; D=39
<b>TICO (KLY3)</b>			<b>02/1995 → 12/2000</b>		
Control Arm-/Trailing Arm Bush	All Models		<b>F8-6585</b>		
<b>TOSCA</b>			<b>02/2006 →</b>		
Alternator Freewheel Clutch	2.0 TDCi		<b>F5-1001</b>		

<b>AK-735317</b>	<b>AK-735318</b>	<b>F5-1001</b>	<b>F8-6585</b>	<b>F8-7937</b>	<b>F8-8219</b>	<b>F8-8221</b>
Ref.Nr.: 96300082	Ref.Nr.: 96403109	Ref.Nr.: 211242	Ref.Nr.: 96 380 613	Ref.Nr.: 96391856	Ref.Nr.: 96378346	Ref.Nr.: 96474041
<b>LM-10059S</b>						
Ref.Nr.: 520738						



Article Description			Article Nr.	Fitting Position	
<b>CHARADE Mk III (G100, G101, G102)</b>			<b>03/1987 → 12/1992</b>		
Dust Cover Kit, shock absorber	1.0, 1.0 D, 1.0 TD, 1.3 i		<b>AK-735113</b>	  	
<b>CHARADE III Saloon (G102)</b>			<b>11/1990 → 02/1993</b>		
Dust Cover Kit, shock absorber	All Models		<b>AK-735113</b>	  	
<b>CUORE Mk VI (L7_)</b>			<b>10/1998 → 05/2003</b>		
Dust Cover Kit, shock absorber	0.7, 1.0, 1.0 i		<b>AK-735325</b>	  	
<b>SIRION (M1)</b>			<b>04/1998 → 03/2005</b>		
Dust Cover Kit, shock absorber	0.7 Turbo 4WD, 1.0, 1.0 i, 1.0 i 4WD, 1.3 Sport, 1.3 Sport 4WD		<b>AK-735325</b>	  	
Rubber Buffer, suspension	0.7 Turbo 4WD, 1.0, 1.0 i, 1.0 i 4WD, 1.3 Sport, 1.3 Sport 4WD		<b>AK-735326</b>	  	
<b>YRV (M2)</b>			<b>02/2001 →</b>		
Dust Cover Kit, shock absorber	All Models		<b>AK-735325</b>	  	
Rubber Buffer, suspension	All Models		<b>AK-735326</b>	  	

		
<b>AK-735113</b>	<b>AK-735325</b>	<b>AK-735326</b>
Ref.Nr.:	Ref.Nr.: 4833187204	Ref.Nr.: 4834187211

Article Description



Article Nr.

Fitting Position



<b>CARAVAN</b>		<b>01/1995 → 03/2001</b>	
Dust Cover Kit, shock absorber	All Models	<b>AK-735139</b>	
<b>NITRO</b>		<b>06/2007 → 12/2012</b>	
Alternator Freewheel Clutch	2.8 CRD, 2.8 CRD 4WD	<b>F5-1033</b>	
<b>RAM 2500 Pickup (D1, DC, DH, DM, DR)</b>		<b>01/2002 → 12/2009</b>	
Alternator Freewheel Clutch	5.9 Di	<b>F5-1089</b>	
<b>RAM 3500 [USA]</b>		<b>01/2007 → 12/2007</b>	
Alternator Freewheel Clutch	6.7 24V DIESEL	<b>F5-1117</b>	

<b>AK-735139</b>	<b>F5-1033</b>	<b>F5-1089</b>	<b>F5-1117</b>
Ref.Nr.:	Ref.Nr.: 53013554AF	Ref.Nr.: 053183490AA	Ref.Nr.:



**Article Description****Article Nr.****Fitting Position**

<b>126 (126_)</b>				<b>07/1977 → 09/2000</b>	
Bellow, steering	650, 700	; with clamps	<b>LM-10043S</b>	⊕	d1=10; d2=26; L [mm]=165
Bellow, steering	650, 700	; with clamps	<b>LM-10043S</b>	⊕	d1=10; d2=26; L [mm]=165
Bellow, steering	650, 700	; with clamps	<b>LM-10053S</b>	⊕	d1=10; d2=42; L [mm]=125
Bellow, steering	650, 700	; with clamps	<b>LM-10053S</b>	⊕	d1=10; d2=42; L [mm]=125
<b>128 Coupe (128_)</b>				<b>03/1972 → 02/1981</b>	
Control Arm-/Trailing Arm Bush	All Models		<b>G9-506</b>	⊕ ⊕	H=37; d=9; D1=25; D2=36
<b>131 (131_)</b>				<b>10/1974 → 12/1984</b>	
Holder, control arm mounting	All Models		<b>G9-504</b>	⊕ ⊕	H=16; d=19; D1=26; D2=30
<b>500 (312)</b>				<b>10/2007 →</b>	
Alternator Freewheel Clutch	1.3 D Multijet		<b>F5-1041</b>		
Alternator Freewheel Clutch	1.3 D Multijet		<b>F5-1045</b>		
Control Arm-/Trailing Arm Bush	1.2, 1.3 D Multijet, 1.4		<b>F8-6450</b>	⊕ ⊕	
Spring Cap	0.9, 1.2, 1.2 LPG, 1.3 D Multijet, 1.4		<b>F8-6560</b>		
Belt Pulley, crankshaft	1.3 D Multijet	Number of Ribs: 6	<b>F8-7086</b>		Belt Pulley Ø [mm]=165; Mounting points diam.[mm]=35; W=30
Top Strut Mounting	1.2, 1.3 D Multijet, 1.4		<b>F8-7427</b>	⊕ ⊕	
Rubber Buffer, suspension	0.9, 1.2, 1.2 LPG, 1.3 D Multijet, 1.4		<b>F8-7484</b>	⊕ ⊕	
Rubber Buffer, suspension	0.9, 1.2, 1.2 LPG, 1.3 D Multijet, 1.4		<b>F8-7594</b>	⊕ ⊕	H=228
<b>500 C (312)</b>				<b>09/2009 →</b>	
Alternator Freewheel Clutch	1.3 D Multijet		<b>F5-1041</b>		
Alternator Freewheel Clutch	1.3 D Multijet		<b>F5-1045</b>		
Rubber Buffer, suspension	0.9, 1.2, 1.3 D Multijet, 1.4		<b>F8-7484</b>	⊕ ⊕	
Rubber Buffer, suspension	1.2, 1.3 D Multijet, 1.4		<b>F8-7594</b>	⊕ ⊕	H=228
<b>500L (199_)</b>				<b>09/2012 →</b>	
Alternator Freewheel Clutch	1.6 D Multijet		<b>F5-1072</b>		
Rubber Buffer, suspension	0.9, 1.3 D Multijet, 1.4		<b>F8-7484</b>	⊕ ⊕	
<b>ARGENTA (132A)</b>				<b>06/1978 → 07/1986</b>	
Anti-Friction Bearing	All Models		<b>F8-3017</b>	⊕ ⊕	d=50; D=70
<b>BARCETTA (183)</b>				<b>04/1995 → 05/2005</b>	
Mounting, axle beam	All Models		<b>F8-5864</b>	⊕ ⊕	H=29; d=16; D=72
Bearing Bush, stabiliser	All Models		<b>F8-6731</b>	⊕ ⊕	
Control Arm-/Trailing Arm Bush	All Models		<b>G9-533</b>	⊕ ⊕	H=55; D1=32; D2=38

<b>F5-1041</b>	<b>F5-1045</b>	<b>F5-1072</b>	<b>F8-3017</b>	<b>F8-5864</b>	<b>F8-6450</b>	<b>F8-6560</b>
Ref.Nr.: 77364723	Ref.Nr.: 77362721	Ref.Nr.: 30667067	Ref.Nr.: 4400895	Ref.Nr.: 46476755	Ref.Nr.: 46551790	Ref.Nr.: 46541086
<b>F8-6731</b>	<b>F8-7086</b>	<b>F8-7427</b>	<b>F8-7484</b>	<b>F8-7594</b>	<b>G9-504</b>	<b>G9-506</b>
Ref.Nr.: 7750990	Ref.Nr.: 55200498	Ref.Nr.: 51807101	Ref.Nr.: 51811829	Ref.Nr.: 1 639 562	Ref.Nr.: 4331968	Ref.Nr.: 0004288726
<b>G9-533</b>	<b>G9-584</b>	<b>LM-10043S</b>	<b>LM-10053S</b>			
Ref.Nr.: 7673581	Ref.Nr.: 7775344R	Ref.Nr.: 7583243	Ref.Nr.: 7583242			

Article Description



Article Nr.

Fitting Position



<b>BARCETTA (183)</b>		<b>04/1995 → 05/2005</b>	
Control Arm-/Trailing Arm Bush	All Models	<b>G9-584</b>	
Control Arm-/Trailing Arm Bush	All Models	<b>G9-612</b>	
<b>BRAVA (182)</b>		<b>10/1995 → 12/2002</b>	
Dust Cover Kit, shock absorber	1.2 16V 80, 1.4, 1.4 12 V, 1.6 16V, 1.8 GT 16V, 1.9 D, 1.9 JTD 105, 1.9 TD 100 S, 1.9 TD 75 S	<b>AK-735010</b>	
Dust Cover Kit, shock absorber	1.2 16V 80, 1.4, 1.4 12 V, 1.6 16V, 1.8 GT 16V, 1.9 D, 1.9 JTD, 1.9 JTD 105, 1.9 TD 100 S, 1.9 TD 75 S	<b>AK-735337</b>	
Alternator Freewheel Clutch	1.9 D, 1.9 JTD, 1.9 JTD 105, 1.9 TD 100 S, 1.9 TD 75 S	<b>F5-1005</b>	
Alternator Freewheel Clutch	1.9 D, 1.9 JTD, 1.9 JTD 105, 1.9 TD 100 S, 1.9 TD 75 S	<b>F5-1123</b>	
Anti-Friction Bearing	1.4, 1.4 12 V, 1.6 16V	<b>F8-3015</b>	H=48; d1=79; d2=84; D1=116; D2=128
Stabiliser Mounting	1.4, 1.4 12 V, 1.6 16V, 1.8 GT 16V, 1.9 TD 100 S, 1.9 TD 75 S	<b>F8-5094</b>	d=22
Top Strut Mounting	1.4, 1.4 12 V, 1.6 16V	<b>F8-5513</b>	
Top Strut Mounting	1.4, 1.4 12 V, 1.6 16V	<b>F8-5514</b>	
Top Strut Mounting	1.2 16V 80, 1.4, 1.4 12 V, 1.6 16V, 1.8 GT 16V, 1.9 D, 1.9 JTD, 1.9 JTD 105, 1.9 TD 100 S, 1.9 TD 75 S	<b>F8-5600</b>	
Rubber Buffer, suspension	1.2 16V 80, 1.4, 1.4 12 V, 1.6 16V, 1.8 GT 16V, 1.9 D, 1.9 JTD, 1.9 JTD 105, 1.9 TD 100 S, 1.9 TD 75 S	<b>F8-5938</b>	
Spring Cap	1.4, 1.4 12 V, 1.6 16V	<b>F8-5956</b>	
Belt Pulley, crankshaft	1.9 JTD, 1.9 JTD 105, 1.9 TD 100 S, 1.9 TD 75 S	Number of Ribs: 5; Parameter: 6PK; with screw set <b>F8-6393</b>	D=169
Engine Mounting	1.8 GT 16V	<b>F8-6631</b>	
Engine Mounting	1.6 16V	<b>F8-6632</b>	
Engine Mounting	1.6 16V	<b>F8-6936</b>	
Engine Mounting	1.4, 1.4 12 V	<b>F8-6939</b>	
Engine Mounting	1.4, 1.4 12 V	<b>F8-6940</b>	
Engine Mounting	1.4, 1.4 12 V	<b>F8-6941</b>	
Rubber Buffer, suspension	1.2 16V 80, 1.4, 1.4 12 V, 1.6 16V, 1.8 GT 16V, 1.9 D, 1.9 JTD, 1.9 JTD 105, 1.9 TD 100 S, 1.9 TD 75 S	<b>F8-7595</b>	
Belt Pulley, crankshaft	1.2 16V 80	<b>F8-7648</b>	
Repair Set, axle beam	1.2 16V 80, 1.4, 1.4 12 V, 1.6 16V, 1.8 GT 16V, 1.9 D, 1.9 JTD, 1.9 JTD 105, 1.9 TD 100 S, 1.9 TD 75 S	<b>G8-555</b>	
Control Arm-/Trailing Arm Bush	1.2 16V 80, 1.4, 1.4 12 V, 1.6 16V, 1.8 GT 16V, 1.9 JTD 105, 1.9 TD 100 S, 1.9 TD 75 S	<b>G9-530</b>	H=50; d=20; D=41
Control Arm-/Trailing Arm Bush	1.9 D	for OE: 43423822 <b>G9-530</b>	H=50; d=20; D=41

<b>AK-735010</b>	<b>AK-735337</b>	<b>F5-1005</b>	<b>F5-1123</b>	<b>F8-3015</b>	<b>F8-5094</b>	<b>F8-5513</b>
Ref.Nr.:	Ref.Nr.: 7599485	Ref.Nr.: 9951162	Ref.Nr.: 9948513	Ref.Nr.: 7601502	Ref.Nr.: 07760424	Ref.Nr.: 46414184
<b>F8-5514</b>	<b>F8-5600</b>	<b>F8-5938</b>	<b>F8-5956</b>	<b>F8-6393</b>	<b>F8-6631</b>	<b>F8-6632</b>
Ref.Nr.: 46414184	Ref.Nr.: 46445246	Ref.Nr.: 46404169	Ref.Nr.: 7602150	Ref.Nr.: 55196301	Ref.Nr.: 077 824 35	Ref.Nr.: 60813084
<b>F8-6936</b>	<b>F8-6939</b>	<b>F8-6940</b>	<b>F8-6941</b>	<b>F8-7595</b>	<b>F8-7648</b>	<b>G8-555</b>
Ref.Nr.: 7778563	Ref.Nr.: 7764084	Ref.Nr.: 7765921	Ref.Nr.: 7764414	Ref.Nr.: 46404169	Ref.Nr.: 7778028	Ref.Nr.:

**Article Description****Article Nr.****Fitting Position**

<b>BRAVA (182)</b>				<b>10/1995 → 12/2002</b>	
Control Arm-/Trailing Arm Bush	1.2 16V 80, 1.4, 1.4 12 V, 1.6 16V, 1.8 GT 16V, 1.9 JTD 105, 1.9 TD 100 S, 1.9 TD 75 S		<b>G9-531</b>		H=52; d=20; D=59
Control Arm-/Trailing Arm Bush	1.9 D	for OE: 46423823	<b>G9-531</b>		H=52; d=20; D=59
Control Arm-/Trailing Arm Bush	1.2 16V 80, 1.4, 1.4 12 V, 1.6 16V, 1.8 GT 16V, 1.9 JTD 105, 1.9 TD 100 S, 1.9 TD 75 S		<b>G9-532</b>		H=53; d=20; D=58
Control Arm-/Trailing Arm Bush	1.9 D	for OE: 43423822	<b>G9-532</b>		H=53; d=20; D=58
<b>BRAVO I (182)</b>				<b>10/1995 → 10/2001</b>	
Dust Cover Kit, shock absorber	1.2 16V 80, 1.4, 1.6 16V, 1.8 GT, 1.9 D, 1.9 JTD 105, 1.9 TD 100 S, 1.9 TD 75 S, 2.0 HGT 20V		<b>AK-735010</b>		
Dust Cover Kit, shock absorber	1.2 16V 80, 1.4, 1.6 16V, 1.8 GT, 1.9 D, 1.9 JTD, 1.9 JTD 105, 1.9 TD 100 S, 1.9 TD 75 S, 2.0 HGT 20V		<b>AK-735337</b>		
Alternator Freewheel Clutch	1.9 D, 1.9 JTD, 1.9 JTD 105, 1.9 TD 100 S, 1.9 TD 75 S		<b>F5-1005</b>		
Alternator Freewheel Clutch	1.9 D, 1.9 JTD, 1.9 JTD 105, 1.9 TD 100 S, 1.9 TD 75 S		<b>F5-1123</b>		
Anti-Friction Bearing	1.4, 1.6 16V		<b>F8-3015</b>		H=48; d1=79; d2=84; D1=116; D2=128
Anti-Friction Bearing	2.0 HGT 20V	<b>SP</b>	<b>F8-3015</b>		H=48; d1=79; d2=84; D1=116; D2=128
Stabiliser Mounting	1.4, 1.6 16V, 1.8 GT, 1.9 TD 100 S, 1.9 TD 75 S, 2.0 HGT 20V		<b>F8-5094</b>		d=22
Top Strut Mounting	1.4, 1.6 16V, 2.0 HGT 20V		<b>F8-5513</b>		
Top Strut Mounting	1.4, 1.6 16V, 2.0 HGT 20V		<b>F8-5514</b>		
Top Strut Mounting	1.2 16V 80, 1.4, 1.6, 1.6 16V, 1.8 GT, 1.9 D, 1.9 JTD, 1.9 JTD 105, 1.9 TD 100 S, 1.9 TD 75 S, 2.0 HGT 20V		<b>F8-5600</b>		
Rubber Buffer, suspension	1.2 16V 80, 1.4, 1.6, 1.6 16V, 1.8 GT, 1.9 D, 1.9 JTD, 1.9 JTD 105, 1.9 TD 100 S, 1.9 TD 75 S, 2.0 HGT 20V		<b>F8-5938</b>		
Spring Cap	1.4, 1.6, 1.6 16V, 2.0 HGT 20V		<b>F8-5956</b>		
Belt Pulley, crankshaft	1.9 JTD, 1.9 JTD 105, 1.9 TD 100 S, 1.9 TD 75 S	Number of Ribs: 5; Parameter: 6PK; with screw set	<b>F8-6393</b>		D=169
Engine Mounting	1.8 GT, 2.0 HGT 20V		<b>F8-6631</b>		
Engine Mounting	1.6, 1.6 16V, 2.0 HGT 20V		<b>F8-6632</b>		
Engine Mounting	1.6 16V		<b>F8-6936</b>		
Engine Mounting	1.4		<b>F8-6939</b>		
Engine Mounting	1.4		<b>F8-6940</b>		
Engine Mounting	1.4		<b>F8-6941</b>		
Rubber Buffer, suspension	1.2 16V 80, 1.4, 1.6, 1.6 16V, 1.8 GT, 1.9 D, 1.9 JTD, 1.9 JTD 105, 1.9 TD 100 S, 1.9 TD 75 S, 2.0 HGT 20V		<b>F8-7595</b>		



Article Description



Article Nr.

Fitting Position



<b>BRAVO I (182)</b>		<b>10/1995 → 10/2001</b>	
Belt Pulley, crankshaft	1.2 16V 80		<b>F8-7648</b>
Repair Set, axle beam	1.2 16V 80, 1.4, 1.6 16V, 1.8 GT, 1.9 D, 1.9 JTD, 1.9 JTD 105, 1.9 TD 100 S, 1.9 TD 75 S, 2.0 HGT 20V		<b>G8-555</b>
Control Arm-/Trailing Arm Bush	1.2 16V 80, 1.4, 1.6 16V, 1.8 GT, 1.9 JTD 105, 1.9 TD 100 S, 1.9 TD 75 S, 2.0 HGT 20V		<b>G9-530</b>
Control Arm-/Trailing Arm Bush	1.9 D	for OE: 43423822	<b>G9-530</b>
Control Arm-/Trailing Arm Bush	1.2 16V 80, 1.4, 1.6 16V, 1.8 GT, 1.9 JTD 105, 1.9 TD 100 S, 1.9 TD 75 S		<b>G9-531</b>
Control Arm-/Trailing Arm Bush	1.9 D	for OE: 46423823	<b>G9-531</b>
Control Arm-/Trailing Arm Bush	1.2 16V 80, 1.4, 1.6 16V, 1.8 GT, 1.9 JTD 105, 1.9 TD 100 S, 1.9 TD 75 S		<b>G9-532</b>
Control Arm-/Trailing Arm Bush	1.9 D	for OE: 43423822	<b>G9-532</b>
<b>BRAVO II (198)</b>		<b>11/2006 → 12/2008</b>	
Dust Cover Kit, shock absorber	1.4, 1.4 T-Jet, 1.6 D Multijet, 1.9 D Multijet		<b>AK-735338</b>
Dust Cover Kit, shock absorber	1.4, 1.4 T-Jet, 1.6 D Multijet, 1.9 D Multijet		<b>AK-735339</b>
Alternator Freewheel Clutch	1.4, 1.4 T-Jet, 1.6 D Multijet, 1.9 D Multijet, 2.0 D Multijet		<b>F5-1098</b>
Alternator Freewheel Clutch	1.4, 1.4 T-Jet, 1.6 D Multijet, 1.9 D Multijet		<b>F5-1123</b>
<b>BRAVO Van (198)</b>		<b>03/2008 →</b>	
Alternator Freewheel Clutch	All Models		<b>F5-1098</b>
Alternator Freewheel Clutch	All Models		<b>F5-1123</b>
<b>CINQUECENTO (170)</b>		<b>07/1991 → 07/1999</b>	
Dust Cover Kit, shock absorber	0.7, 0.7 i, 0.9, 0.9 i.e., 0.9 i.e. S		<b>AK-735116</b>
Dust Cover Kit, shock absorber	All Models		<b>AK-735137</b>
Top Strut Mounting	All Models		<b>F8-5598</b>
Engine Mounting	0.9, 0.9 i.e.		<b>F8-6896</b>
Engine Mounting	0.9 i.e. S	1170 A1.046, 1170A1.000	<b>F8-6896</b>
Engine Mounting	0.7, 0.7 i		<b>F8-6919</b>
Engine Mounting	0.7, 0.7 i		<b>F8-6920</b>
Mounting, automatic transmission	0.7, 0.7 i		<b>F8-7029</b>
Bearing, drive shaft	0.7, 0.7 i		<b>F8-7173</b>
Control Arm-/Trailing Arm Bush	0.7, 0.7 i, 0.9, 0.9 i.e. S, 1.1 Sporting		<b>G9-533</b>
Control Arm-/Trailing Arm Bush	0.7, 0.7 i, 0.9, 0.9 i.e. S, 1.1 Sporting		<b>G9-534</b>

<b>AK-735116</b>	<b>AK-735137</b>	<b>AK-735338</b>	<b>AK-735339</b>	<b>F5-1098</b>	<b>F5-1123</b>	<b>F8-5598</b>
Ref.Nr.:	Ref.Nr.:	Ref.Nr.: 50709096	Ref.Nr.: 51797478	Ref.Nr.: 77364725	Ref.Nr.: 9948513	Ref.Nr.: 7667087
<b>F8-6896</b>	<b>F8-6919</b>	<b>F8-6920</b>	<b>F8-7029</b>	<b>F8-7173</b>	<b>F8-7648</b>	<b>G8-555</b>
Ref.Nr.: 46749600	Ref.Nr.: 7708182	Ref.Nr.: 7708183	Ref.Nr.: 7670108	Ref.Nr.: 7664079	Ref.Nr.: 7778028	Ref.Nr.:
<b>G9-530</b>	<b>G9-531</b>	<b>G9-532</b>	<b>G9-533</b>	<b>G9-534</b>		
Ref.Nr.: 7601064	Ref.Nr.: 7601068	Ref.Nr.: 7601065	Ref.Nr.: 7673581	Ref.Nr.: 5927293		

**Article Description****Article Nr.****Fitting Position**

<b>COUPE (FA/175)</b>				<b>11/1993 → 08/2000</b>	
Dust Cover Kit, shock absorber	All Models			<b>AK-735340</b>	
Dust Cover Kit, shock absorber	All Models			<b>AK-735341</b>	
Anti-Friction Bearing	1.8 16V, 2.0 16V, 2.0 16V Turbo, 2.0 20V, 2.0 20V Turbo			<b>F8-3015</b>	H=48; d1=79; d2=84; D1=116; D2=128
Stabiliser Mounting	1.8 16V, 2.0 16V, 2.0 16V Turbo, 2.0 20V, 2.0 20V Turbo			<b>F8-5094</b>	d=22
Spring Cap	All Models			<b>F8-5956</b>	
Engine Mounting	1.8 16V, 2.0 16V, 2.0 20V			<b>F8-6631</b>	
Control Arm-/Trailing Arm Bush	All Models			<b>G9-530</b>	H=50; d=20; D=41
Bellow, steering	1.8 16V, 2.0 16V Turbo, 2.0 20V	with clamps		<b>LM-10008S</b>	d1=11; d2=55; L [mm]=214
Bellow, steering	1.8 16V, 2.0 16V Turbo, 2.0 20V	with clamps		<b>LM-10025S</b>	d1=10.5; d2=56; L [mm]=202.2
<b>CROMA (154)</b>				<b>12/1985 → 12/1996</b>	
Top Strut Mounting	1900 Turbo D i.d. , 2000 16V, 2000 CHT , 2000 i.e. , 2000 i.e. Turbo , 2500 V6			<b>F8-5591</b>	
Top Strut Mounting	1900 Turbo D i.d. , 2000 16V, 2000 CHT , 2000 i.e. , 2000 i.e. Turbo , 2500 V6			<b>F8-5592</b>	
Top Strut Mounting	2500 D, 2500 TD			<b>F8-5592</b>	
Top Strut Mounting	All Models			<b>F8-5603</b>	H=50; d=14; D=145
Mounting, axle beam	1600, 1900 Turbo D i.d. , 2000 CHT , 2000 i.e. , 2000 i.e. Turbo , 2500 D, 2500 TD , 2500 TDE			<b>F8-5640</b>	
Bellow, steering	1600, 1900 Turbo D i.d. , 2000 i.e. , 2000 i.e. Turbo , 2500 D, 2500 TD , 2500 V6	with clamps;		<b>LM-10060S</b>	d1=10; d2=48; L [mm]=170
<b>CROMA (194)</b>				<b>06/2005 →</b>	
Dust Cover Kit, shock absorber	1.8 16V, 1.9 D Multijet, 2.2 16V, 2.4 D Multijet			<b>AK-735342</b>	
Alternator Freewheel Clutch	2.4 D Multijet			<b>F5-1067</b>	
Alternator Freewheel Clutch	1.9 D Multijet			<b>F5-1098</b>	
Alternator Freewheel Clutch	1.9 D Multijet			<b>F5-1123</b>	
Control Arm-/Trailing Arm Bush	1.8 16V, 1.9 D Multijet, 2.2 16V, 2.4 D Multijet			<b>F8-6446</b>	H=60; d=12.2; D1=36; D2=43
Control Arm-/Trailing Arm Bush	1.8 16V, 1.9 D Multijet, 2.2 16V, 2.4 D Multijet			<b>F8-6447</b>	
Belt Pulley, crankshaft	2.4 D Multijet	Number of Ribs: 6		<b>F8-7087</b>	Belt Pulley Ø [mm]=181; Mounting points diam.[mm]=30; W=32
Anti-Friction Bearing	1.8 16V, 1.9 D Multijet, 2.2 16V, 2.4 D Multijet			<b>F8-7172</b>	
Top Strut Mounting	1.8 16V, 1.9 D Multijet, 2.2 16V, 2.4 D Multijet			<b>F8-7329</b>	
Top Strut Mounting	1.8 16V, 1.9 D Multijet, 2.2 16V, 2.4 D Multijet			<b>F8-7330</b>	
Protective Cap/Bellow, shock absorber	All Models			<b>F8-7663</b>	H=205



Article Description

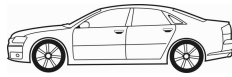

Article Nr.

Fitting Position



### DOBLO MPV (223, 119)

03/2001 →

Alternator Freewheel Clutch	1.9 JTD		<b>F5-1005</b>		
Alternator Freewheel Clutch	1.3 D Multijet, 1.3 JTD		<b>F5-1041</b>		
Alternator Freewheel Clutch	1.3 D Multijet, 1.3 JTD		<b>F5-1045</b>		
Alternator Freewheel Clutch	1.9 D , 1.9 D Multijet, 1.9 JTD		<b>F5-1123</b>		
Control Arm-/Trailing Arm Bush	1.2 , 1.6 16V , 1.9 D , 1.9 JTD		<b>F8-6244</b>		
Control Arm-/Trailing Arm Bush	1.2 , 1.6 16V , 1.9 D , 1.9 JTD		<b>F8-6245</b>		
Top Strut Mounting	1.2 , 1.6 16V , 1.9 D , 1.9 JTD		<b>F8-6367</b>		
Belt Pulley, crankshaft	1.9 D , 1.9 JTD	Number of Ribs: 5; Parameter: 6PK; with screw set	<b>F8-6393</b>		D=169
Bush, leaf spring	1.2 , 1.3 D Multijet, 1.4, 1.6 16V , 1.6 Natural Power, 1.9 D , 1.9 D Multijet, 1.9 JTD		<b>F8-6602</b>		H=77; d=14; D=34.4
Bush, leaf spring	1.2 , 1.3 D Multijet, 1.3 JTD, 1.4, 1.6, 1.6 16V , 1.6 Natural Power, 1.9 D , 1.9 D Multijet, 1.9 JTD		<b>F8-6603</b>		H=78; d=17; D=56
Bush, leaf spring	1.2 , 1.3 D Multijet, 1.3 JTD, 1.4, 1.6, 1.6 16V , 1.6 Natural Power, 1.9 D , 1.9 D Multijet, 1.9 JTD		<b>F8-6604</b>		
Engine Mounting	1.6 16V , 1.6 Natural Power		<b>F8-6605</b>		
Engine Mounting	1.6 16V , 1.6 Natural Power		<b>F8-6606</b>		
Engine Mounting	1.3 D Multijet, 1.3 JTD, 1.9 D , 1.9 D Multijet, 1.9 JTD		<b>F8-6607</b>		
Engine Mounting	1.2		<b>F8-6608</b>		
Engine Mounting	1.6 16V , 1.6 Natural Power		<b>F8-6609</b>		
Bearing Bush, stabiliser	1.2 , 1.6 16V , 1.6 Natural Power, 1.9 D , 1.9 JTD		<b>F8-6731</b>		
Belt Pulley, crankshaft	1.9 D	Number of Ribs: 6	<b>F8-7085</b>		Belt Pulley Ø [mm]=168; W=35.5
Top Strut Mounting	1.2 , 1.6 16V , 1.9 D , 1.9 JTD		<b>F8-7158</b>		
Belt Pulley, crankshaft	1.3 D Multijet, 1.3 JTD	Number of grooves: 4, 6; Number of Ribs: 3, 5; Parameter: 4PK+6PK	<b>F8-7647</b>		d=35.03; Mounting points diam.[mm]=8.5; D1=164.9; D2=145
Belt Pulley, crankshaft	1.2	Engine →1731672;	<b>F8-7648</b>		
Protective Cap/Bellow, shock absorber	1.2 , 1.3 D Multijet, 1.3 JTD, 1.4, 1.6, 1.6 16V , 1.9 D Multijet, 1.9 JTD	01/2009 →	<b>F8-7663</b>		H=205
Protective Cap/Bellow, shock absorber	1.6 Natural Power		<b>F8-7663</b>		H=205

### DOBLO Cargo (223)

03/2001 → 01/2010

Alternator Freewheel Clutch	1.9 JTD		<b>F5-1005</b>		
Alternator Freewheel Clutch	1.3 D Multijet, 1.3 JTD 16V, 1.3 JTD 16V Multijet		<b>F5-1041</b>		
Alternator Freewheel Clutch	1.3 D Multijet, 1.3 JTD 16V, 1.3 JTD 16V Multijet		<b>F5-1045</b>		
Alternator Freewheel Clutch	1.9 D , 1.9 JTD , 1.9 JTD Multijet		<b>F5-1123</b>		
Control Arm-/Trailing Arm Bush	1.2 , 1.6 16V , 1.9 D , 1.9 JTD		<b>F8-6244</b>		

<b>F5-1005</b>	<b>F5-1041</b>	<b>F5-1045</b>	<b>F5-1123</b>	<b>F8-6244</b>	<b>F8-6245</b>	<b>F8-6367</b>
Ref.Nr.: 9951162	Ref.Nr.: 77364723	Ref.Nr.: 77362721	Ref.Nr.: 9948513	Ref.Nr.: 46748578	Ref.Nr.: 46748579	Ref.Nr.: 46760673
<b>F8-6393</b>	<b>F8-6602</b>	<b>F8-6603</b>	<b>F8-6604</b>	<b>F8-6605</b>	<b>F8-6606</b>	<b>F8-6607</b>
Ref.Nr.: 55196301	Ref.Nr.: 7743792	Ref.Nr.: 46767261	Ref.Nr.: 46766963	Ref.Nr.: 46820471	Ref.Nr.: 46830162	Ref.Nr.: 46759737
<b>F8-6608</b>	<b>F8-6609</b>	<b>F8-6731</b>	<b>F8-7085</b>	<b>F8-7158</b>	<b>F8-7647</b>	<b>F8-7648</b>
Ref.Nr.: 46761804	Ref.Nr.: 46773925	Ref.Nr.: 7750990	Ref.Nr.: 46770939	Ref.Nr.: 46760674	Ref.Nr.: 55182506	Ref.Nr.: 7778028

**Article Description****Article Nr.****Fitting Position**

<b>DOBLO Cargo (223)</b>		<b>03/2001 → 01/2010</b>	
Control Arm-/Trailing Arm Bush	1.2, 1.6 16V, 1.9 D, 1.9 JTD	F8-6245	
Top Strut Mounting	1.2, 1.3 JTD 16V, 1.6 16V, 1.9 D, 1.9 JTD	F8-6367	
Bush, leaf spring	1.2, 1.3 D Multijet, 1.3 JTD 16V, 1.4, 1.6 16V, 1.6 Natural Power, 1.9 D, 1.9 JTD	F8-6602	
Bush, leaf spring	1.2, 1.3 D Multijet, 1.3 JTD 16V, 1.4, 1.6 16V, 1.6 Natural Power, 1.9 D, 1.9 JTD	F8-6603	
Bush, leaf spring	1.2, 1.3 D Multijet, 1.3 JTD 16V, 1.4, 1.6 16V, 1.6 Natural Power, 1.9 D, 1.9 JTD	F8-6604	
Engine Mounting	1.6 16V, 1.6 Natural Power	F8-6605	
Engine Mounting	1.6 16V, 1.6 Natural Power	F8-6606	
Engine Mounting	1.3 D Multijet, 1.3 JTD 16V, 1.9 D, 1.9 JTD	F8-6607	
Engine Mounting	1.2	F8-6608	
Engine Mounting	1.6 16V, 1.6 Natural Power	F8-6609	
Bearing Bush, stabiliser	1.2, 1.6 16V, 1.6 Natural Power, 1.9 D, 1.9 JTD	F8-6731	
Belt Pulley, crankshaft	1.9 D	02/2002 →; Number of Ribs: 6	F8-7085
Top Strut Mounting	1.2, 1.3 JTD 16V, 1.6 16V, 1.9 D, 1.9 JTD	F8-7158	
Belt Pulley, crankshaft	1.3 D Multijet, 1.3 JTD 16V	Number of grooves: 4, 6; Number of Ribs: 3, 5; Parameter: 4PK+6PK	F8-7647
Belt Pulley, crankshaft	1.2	Engine →1731672;	F8-7648
Protective Cap/Bellow, shock absorber	1.3 D Multijet, 1.3 JTD 16V Multijet, 1.4, 1.9 JTD	01/2009 →	F8-7663
<b>DOBLO Combi (152, 263_)</b>		<b>02/2010 →</b>	
Alternator Freewheel Clutch	1.3 D Multijet	F5-1041	
Alternator Freewheel Clutch	1.6 D Multijet, 2.0 D Multijet	F5-1072	
Alternator Freewheel Clutch	1.6 D Multijet, 2.0 D Multijet	F5-1098	
Protective Cap/Bellow, shock absorber	1.3 D Multijet, 1.4, 1.4 Natural Power, 1.6 D Multijet, 2.0 D Multijet	F8-7663	
<b>DOBLO Box Body / Estate (263)</b>		<b>02/2010 →</b>	
Alternator Freewheel Clutch	1.3 D Multijet	F5-1041	
Alternator Freewheel Clutch	1.6 D Multijet, 2.0 D Multijet	F5-1072	
Alternator Freewheel Clutch	1.6 D Multijet, 2.0 D Multijet	F5-1098	
Protective Cap/Bellow, shock absorber	1.3 D Multijet, 1.4, 1.4 Natural Power, 1.6 D Multijet, 2.0 D Multijet	F8-7663	
<b>DOBLO Platform/Chassis (263)</b>		<b>02/2010 →</b>	
Alternator Freewheel Clutch	1.3 D Multijet	F5-1041	
Alternator Freewheel Clutch	1.6 D Multijet, 2.0 D Multijet	F5-1072	

<b>F5-1041</b>	<b>F5-1072</b>	<b>F5-1098</b>	<b>F8-6245</b>	<b>F8-6367</b>	<b>F8-6602</b>	<b>F8-6603</b>
Ref.Nr.: 77364723	Ref.Nr.: 30667067	Ref.Nr.: 77364725	Ref.Nr.: 46748579	Ref.Nr.: 46760673	Ref.Nr.: 7743792	Ref.Nr.: 46767261
<b>F8-6604</b>	<b>F8-6605</b>	<b>F8-6606</b>	<b>F8-6607</b>	<b>F8-6608</b>	<b>F8-6609</b>	<b>F8-6731</b>
Ref.Nr.: 46766963	Ref.Nr.: 46820471	Ref.Nr.: 46830162	Ref.Nr.: 46759737	Ref.Nr.: 46761804	Ref.Nr.: 46773925	Ref.Nr.: 7750990
<b>F8-7085</b>	<b>F8-7158</b>	<b>F8-7647</b>	<b>F8-7648</b>	<b>F8-7663</b>		
Ref.Nr.: 46770939	Ref.Nr.: 46760674	Ref.Nr.: 55182506	Ref.Nr.: 7778028	Ref.Nr.: 344435		

Article Description



Article Nr.

Fitting Position



<b>DOBLO Platform/Chassis (263)</b>			<b>02/2010 →</b>	
Alternator Freewheel Clutch	1.6 D Multijet, 2.0 D Multijet		<b>F5-1098</b>	
Protective Cap/Bellow, shock absorber	1.3 D Multijet, 1.4, 1.6 D Multijet, 2.0 D Multijet		<b>F8-7663</b>	H=205
<b>DUCATO Box (280)</b>			<b>01/1982 → 09/1990</b>	
Dust Cover Kit, shock absorber	1.8, 2.0, 2.4 D, 2.5 D	ch.0284194 →	<b>AK-735070</b>	
Dust Cover Kit, shock absorber	1.9 D, 1.9 TD, 2.0, 2.5 D 4x4	[kg]: 1000, 1400	<b>AK-735070</b>	
Anti-Friction Bearing	1.8, 1.9 D, 1.9 TD, 2.0, 2.4 D, 2.5 D, 2.5 D 4x4		<b>F8-3013</b>	H=7; d=49; D=71
Tie Bar Bush	2.0, 2.4 D, 2.5 D		<b>F8-5084</b>	H=24.5; H1=20.5; d=22; D=48
Top Strut Mounting	1.8, 1.9 D, 1.9 TD, 2.0, 2.4 D, 2.5 D, 2.5 D 4x4	also for special vehicles;	<b>F8-5353</b>	
Top Strut Mounting	1.8, 1.9 D, 1.9 TD, 2.0, 2.4 D, 2.5 D, 2.5 D 4x4	also for special vehicles;	<b>F8-5354</b>	
Top Strut Mounting	1.8, 1.9 D, 1.9 TD, 2.0, 2.4 D, 2.4 D 4x4, 2.5 D, 2.5 D 4x4, 2.5 TD 4x4		<b>F8-5612</b>	
Mounting, leaf spring	2.0, 2.4 D, 2.5 D		<b>F8-5870</b>	H=72; d=16; D=38
Engine Mounting	1.9 D, 1.9 TD, 2.0, 2.4 D, 2.5 D, 2.5 D 4x4		<b>F8-6496</b>	
Engine Mounting	1.9 D, 1.9 TD, 2.0, 2.4 D, 2.5 D		<b>F8-6509</b>	
Top Strut Mounting	2.0, 2.5 D, 2.5 D 4x4	ch.→5616154; not for special purpose vehicles;	<b>F8-8066</b>	
Top Strut Mounting	2.0, 2.5 D, 2.5 D 4x4	ch.5616155→; not for special purpose vehicles;	<b>F8-8066</b>	
Top Strut Mounting	2.0, 2.5 D, 2.5 D 4x4	ch.→5616154; not for special purpose vehicles;	<b>F8-8067</b>	
Top Strut Mounting	2.0, 2.5 D, 2.5 D 4x4	ch.5616155→; not for special purpose vehicles;	<b>F8-8067</b>	
<b>DUCATO Panorama (280)</b>			<b>07/1982 → 08/1990</b>	
Dust Cover Kit, shock absorber	1.8, 2.0, 2.4 D	ch.0284194 →	<b>AK-735070</b>	
Dust Cover Kit, shock absorber	1.9 D, 1.9 TD, 2.0, 2.4 TD, 2.4 TD 4x4, 2.5 D, 2.5 D 4x4		<b>AK-735070</b>	
Anti-Friction Bearing	1.8, 1.9 D, 1.9 TD, 2.0, 2.4 D, 2.4 TD, 2.4 TD 4x4, 2.5 D, 2.5 D 4x4		<b>F8-3013</b>	H=7; d=49; D=71
Tie Bar Bush	2.0, 2.4 D, 2.4 TD		<b>F8-5084</b>	H=24.5; H1=20.5; d=22; D=48
Top Strut Mounting	1.8, 1.9 D, 1.9 TD, 2.0, 2.4 D, 2.4 TD, 2.4 TD 4x4, 2.5 D, 2.5 D 4x4		<b>F8-5612</b>	
Mounting, leaf spring	2.4 D, 2.4 TD		<b>F8-5870</b>	H=72; d=16; D=38
Engine Mounting	1.9 D, 2.0, 2.4 D, 2.4 TD, 2.4 TD 4x4		<b>F8-6496</b>	
Engine Mounting	1.9 D, 1.9 TD, 2.0, 2.4 D, 2.4 TD, 2.4 TD 4x4		<b>F8-6509</b>	
Top Strut Mounting	2.0, 2.5 D, 2.5 D 4x4	ch.→5616154; not for special purpose vehicles;	<b>F8-8066</b>	
Top Strut Mounting	2.0, 2.5 D, 2.5 D 4x4	ch.5616155→; not for special purpose vehicles;	<b>F8-8066</b>	

<b>AK-735070</b>	<b>F5-1098</b>	<b>F8-3013</b>	<b>F8-5084</b>	<b>F8-5353</b>	<b>F8-5354</b>	<b>F8-5612</b>
Ref.Nr.:	Ref.Nr.: 77364725	Ref.Nr.: 503517	Ref.Nr.: 3561.08	Ref.Nr.: 5038.19	Ref.Nr.: 5038.18	Ref.Nr.: 04466980
<b>F8-5870</b>	<b>F8-6496</b>	<b>F8-6509</b>	<b>F8-7663</b>	<b>F8-8066</b>	<b>F8-8067</b>	
Ref.Nr.: 04333710	Ref.Nr.: 1844.41	Ref.Nr.: 1843.61	Ref.Nr.: 344435	Ref.Nr.: 5038.72	Ref.Nr.: 5038.74	



**Article Description****Article Nr.****Fitting Position**

<b>DUCATO Panorama (280)</b>			<b>07/1982 → 08/1990</b>	
Top Strut Mounting	2,0, 2,5 D, 2,5 D 4x4	ch.→5616154; not for special purpose vehicles;	<b>F8-8067</b>	
Top Strut Mounting	2,0, 2,5 D, 2,5 D 4x4	ch.5616155→; not for special purpose vehicles;	<b>F8-8067</b>	
<b>DUCATO Platform/Chassis (280)</b>			<b>07/1982 → 08/1990</b>	
Dust Cover Kit, shock absorber	1,9 D, 1,9 TD, 2,0, 2,5 D 4x4	[kg]: 1000, 1400	<b>AK-735070</b>	
Dust Cover Kit, shock absorber	2,0, 2,4 TD, 2,5 D	ch.0284194→	<b>AK-735070</b>	
Anti-Friction Bearing	1,9 D, 1,9 TD, 2,0, 2,4 TD, 2,5 D, 2,5 D 4x4		<b>F8-3013</b>	H=7; d=49; D=71
Tie Bar Bush	2,4 TD, 2,5 D		<b>F8-5084</b>	H=24.5; H1=20.5; d=22; D=48
Top Strut Mounting	1,9 D, 1,9 TD, 2,0, 2,4 TD, 2,5 D, 2,5 D 4x4		<b>F8-5612</b>	
Mounting, leaf spring	2,5 D		<b>F8-5870</b>	H=72; d=16; D=38
Engine Mounting	1,9 D, 1,9 TD, 2,4 TD		<b>F8-6496</b>	
Engine Mounting	1,9 D, 1,9 TD, 2,4 TD, 2,5 D		<b>F8-6509</b>	
Top Strut Mounting	2,0, 2,5 D, 2,5 D 4x4	ch.→5616154; not for special purpose vehicles;	<b>F8-8066</b>	
Top Strut Mounting	2,0, 2,5 D, 2,5 D 4x4	ch.5616155→; not for special purpose vehicles;	<b>F8-8066</b>	
Top Strut Mounting	2,0, 2,5 D, 2,5 D 4x4	ch.→5616154; not for special purpose vehicles;	<b>F8-8067</b>	
Top Strut Mounting	2,0, 2,5 D, 2,5 D 4x4	ch.5616155→; not for special purpose vehicles;	<b>F8-8067</b>	
<b>DUCATO Box (290)</b>			<b>03/1989 → 05/1994</b>	
Dust Cover Kit, shock absorber	1,9 D, 1,9 TD, 2,5 D 4x4, 2,5 TD, 2,5 TD 4x4	[kg]: 1000, 1400	<b>AK-735070</b>	
Anti-Friction Bearing	1,9 D, 1,9 TD, 2,5 D 4x4, 2,5 TD, 2,5 TD 4x4		<b>F8-3013</b>	H=7; d=49; D=71
Tie Bar Bush	1,9 D, 1,9 TD, 2,5 D 4x4, 2,5 TD, 2,5 TD 4x4		<b>F8-5084</b>	H=24.5; H1=20.5; d=22; D=48
Top Strut Mounting	2,5 TD	01/1994 →; also for special vehicles;	<b>F8-5353</b>	
Top Strut Mounting	2,5 TD	01/1994 →; also for special vehicles;	<b>F8-5354</b>	
Top Strut Mounting	All Models		<b>F8-5612</b>	
Mounting, leaf spring	2,5 TD		<b>F8-5870</b>	H=72; d=16; D=38
Mounting, leaf spring	2,5 TD		<b>F8-5898</b>	H=87; d=16; D=50
Control Arm-/Trailing Arm Bush	1,9 D, 1,9 TD, 2,5 D 4x4, 2,5 TD, 2,5 TD 4x4	for OE: 1320755080, 1320756080, 3520.N3, 3520.N4, 3521.J3, 3521.J4	<b>F8-6114</b>	
Control Arm-/Trailing Arm Bush	2,5 TD		<b>F8-6115</b>	H=55; d=25.5; D1=56; D2=45
Engine Mounting	1,9 D, 1,9 TD, 2,5 TD	09/1990 →	<b>F8-6496</b>	
Engine Mounting	1,9 D, 2,5 D, 2,5 TD		<b>F8-6509</b>	
Engine Mounting	2,5 D 4x4, 2,5 TD, 2,5 TD 4x4		<b>F8-6902</b>	
Engine Mounting	1,9 D		<b>F8-6903</b>	

<b>AK-735070</b>	<b>F8-3013</b>	<b>F8-5084</b>	<b>F8-5353</b>	<b>F8-5354</b>	<b>F8-5612</b>	<b>F8-5870</b>
Ref.Nr.:	Ref.Nr.: 503517	Ref.Nr.: 3561.08	Ref.Nr.: 5038.19	Ref.Nr.: 5038.18	Ref.Nr.: 04466980	Ref.Nr.: 04333710
<b>F8-5898</b>	<b>F8-6114</b>	<b>F8-6115</b>	<b>F8-6496</b>	<b>F8-6509</b>	<b>F8-6902</b>	<b>F8-6903</b>
Ref.Nr.: 5131.73	Ref.Nr.: 1320755080-PA	Ref.Nr.: 3523.93	Ref.Nr.: 1844.41	Ref.Nr.: 1843.61	Ref.Nr.: 7550024	Ref.Nr.: 5934176
<b>F8-8066</b>	<b>F8-8067</b>					
Ref.Nr.: 5038.72	Ref.Nr.: 5038.74					

Article Description



Article Nr.

Fitting Position



<b>DUCATO Box (290)</b>			<b>03/1989 → 05/1994</b>		
Engine Mounting	1.9 TD	01/1990 →	<b>F8-6903</b>		
Engine Mounting	2.5 D 4x4, 2.5 TD, 2.5 TD 4x4		<b>F8-6921</b>		
Top Strut Mounting	2.5 D, 2.5 D 4x4, 2.5 TD, 2.5 TD 4x4	ch.→5616154; not for special purpose vehicles;	<b>F8-8066</b>		
Top Strut Mounting	2.5 D, 2.5 D 4x4, 2.5 TD, 2.5 TD 4x4	ch.5616155→; not for special purpose vehicles;	<b>F8-8066</b>		
Top Strut Mounting	2.5 D, 2.5 D 4x4, 2.5 TD, 2.5 TD 4x4	ch.→5616154; not for special purpose vehicles;	<b>F8-8067</b>		
Top Strut Mounting	2.5 D, 2.5 D 4x4, 2.5 TD, 2.5 TD 4x4	ch.5616155→; not for special purpose vehicles;	<b>F8-8067</b>		
<b>DUCATO Panorama (290)</b>			<b>06/1990 → 05/1994</b>		
Dust Cover Kit, shock absorber	1.9 D, 1.9 TD, 2.0, 2.5 D, 2.5 D 4x4, 2.5 TD, 2.5 TD 4x4		<b>AK-735070</b>		
Anti-Friction Bearing	1.9 D, 1.9 TD, 2.0, 2.5 D, 2.5 D 4x4, 2.5 TD, 2.5 TD 4x4		<b>F8-3013</b>		H=7; d=49; D=71
Tie Bar Bush	1.9 D, 1.9 TD, 2.0, 2.5 D, 2.5 D 4x4, 2.5 TD, 2.5 TD 4x4		<b>F8-5084</b>		H=24.5; H1=20.5; d=22; D=48
Top Strut Mounting	2.0, 2.5 D, 2.5 TD	01/1994 →; also for special vehicles;	<b>F8-5353</b>		
Top Strut Mounting	2.0, 2.5 D, 2.5 TD	01/1994 →; also for special vehicles;	<b>F8-5354</b>		
Top Strut Mounting	All Models		<b>F8-5612</b>		
Mounting, leaf spring	2.0, 2.5 D, 2.5 TD		<b>F8-5870</b>		H=72; d=16; D=38
Mounting, leaf spring	2.0, 2.5 D, 2.5 TD		<b>F8-5898</b>		H=87; d=16; D=50
Control Arm-/Trailing Arm Bush	1.9 D, 1.9 TD, 2.0, 2.5 D, 2.5 D 4x4, 2.5 TD, 2.5 TD 4x4	for OE: 1320755080, 1320756080, 3520.N3, 3520.N4, 3521.J3, 3521.J4	<b>F8-6114</b>		
Control Arm-/Trailing Arm Bush	2.0, 2.5 D, 2.5 TD		<b>F8-6115</b>		H=55; d=25.5; D1=56; D2=45
Engine Mounting	1.9 D, 1.9 TD		<b>F8-6496</b>		
Engine Mounting	2.0, 2.5 D, 2.5 TD	09/1990 →	<b>F8-6496</b>		
Engine Mounting	1.9 TD, 2.5 D, 2.5 D 4x4, 2.5 TD		<b>F8-6509</b>		
Engine Mounting	2.5 D, 2.5 D 4x4, 2.5 TD, 2.5 TD 4x4		<b>F8-6902</b>		
Engine Mounting	1.9 D, 1.9 TD, 2.0		<b>F8-6903</b>		
Engine Mounting	2.5 D, 2.5 D 4x4, 2.5 TD, 2.5 TD 4x4		<b>F8-6921</b>		
Top Strut Mounting	2.0, 2.5 D, 2.5 D 4x4, 2.5 TD, 2.5 TD 4x4	ch.→5616154; not for special purpose vehicles;	<b>F8-8066</b>		
Top Strut Mounting	2.0, 2.5 D, 2.5 D 4x4, 2.5 TD, 2.5 TD 4x4	ch.5616155→; not for special purpose vehicles;	<b>F8-8066</b>		
Top Strut Mounting	2.0, 2.5 D, 2.5 D 4x4, 2.5 TD, 2.5 TD 4x4	ch.→5616154; not for special purpose vehicles;	<b>F8-8067</b>		
Top Strut Mounting	2.0, 2.5 D, 2.5 D 4x4, 2.5 TD, 2.5 TD 4x4	ch.5616155→; not for special purpose vehicles;	<b>F8-8067</b>		

<b>AK-735070</b>	<b>F8-3013</b>	<b>F8-5084</b>	<b>F8-5353</b>	<b>F8-5354</b>	<b>F8-5612</b>	<b>F8-5870</b>
Ref.Nr.:	Ref.Nr.: 503517	Ref.Nr.: 3561.08	Ref.Nr.: 5038.19	Ref.Nr.: 5038.18	Ref.Nr.: 04466980	Ref.Nr.: 04333710
<b>F8-5898</b>	<b>F8-6114</b>	<b>F8-6115</b>	<b>F8-6496</b>	<b>F8-6509</b>	<b>F8-6902</b>	<b>F8-6903</b>
Ref.Nr.: 5131.73	Ref.Nr.: 1320755080-PA	Ref.Nr.: 3523.93	Ref.Nr.: 1844.41	Ref.Nr.: 1843.61	Ref.Nr.: 7550024	Ref.Nr.: 5934176
<b>F8-6921</b>	<b>F8-8066</b>	<b>F8-8067</b>				
Ref.Nr.: 1843.93	Ref.Nr.: 5038.72	Ref.Nr.: 5038.74				

**Article Description****Article Nr.****Fitting Position**

<b>DUCATO Platform/Chassis (290)</b>			<b>03/1989 → 05/1994</b>	
Dust Cover Kit, shock absorber	1.9 TD, 2.0, 2.5 D, 2.5 D 4x4, 2.5 TD, 2.5 TD 4x4	[kg]: 1000, 1400	<b>AK-735070</b>	
Anti-Friction Bearing	1.9 TD, 2.0, 2.5 D, 2.5 D 4x4, 2.5 TD, 2.5 TD 4x4		<b>F8-3013</b>	H=7; d=49; D=71
Tie Bar Bush	1.9 TD, 2.0, 2.5 D, 2.5 D 4x4, 2.5 TD, 2.5 TD 4x4		<b>F8-5084</b>	H=24.5; H1=20.5; d=22; D=48
Top Strut Mounting	2.0, 2.5 TD	01/1994 →; also for special vehicles;	<b>F8-5353</b>	
Top Strut Mounting	2.0, 2.5 TD	01/1994 →; also for special vehicles;	<b>F8-5354</b>	
Top Strut Mounting	All Models		<b>F8-5612</b>	
Mounting, leaf spring	2.0, 2.5 TD		<b>F8-5870</b>	H=72; d=16; D=38
Mounting, leaf spring	2.0, 2.5 TD		<b>F8-5898</b>	H=87; d=16; D=50
Control Arm-/Trailing Arm Bush	1.9 TD, 2.0, 2.5 D, 2.5 D 4x4, 2.5 TD, 2.5 TD 4x4	for OE: 1320755080, 1320756080, 3520.N3, 3520.N4, 3521.J3, 3521.J4	<b>F8-6114</b>	
Control Arm-/Trailing Arm Bush	1.9 TD, 2.0, 2.5 TD		<b>F8-6115</b>	H=55; d=25.5; D1=56; D2=45
Engine Mounting	1.9 TD, 2.5 TD, 2.5 TD 4x4		<b>F8-6496</b>	
Engine Mounting	2.0, 2.5 D	09/1990 →	<b>F8-6496</b>	
Engine Mounting	1.9 TD, 2.5 D, 2.5 TD, 2.5 TD 4x4		<b>F8-6509</b>	
Engine Mounting	2.5 D, 2.5 D 4x4, 2.5 TD, 2.5 TD 4x4		<b>F8-6902</b>	
Engine Mounting	1.9 TD	01/1990 →	<b>F8-6903</b>	
Engine Mounting	2.0		<b>F8-6903</b>	
Engine Mounting	2.5 D, 2.5 D 4x4, 2.5 TD, 2.5 TD 4x4		<b>F8-6921</b>	
Top Strut Mounting	1.9 TD, 2.0, 2.5 D, 2.5 D 4x4, 2.5 TD, 2.5 TD 4x4	ch.→5616154; not for special purpose vehicles;	<b>F8-8066</b>	
Top Strut Mounting	1.9 TD, 2.0, 2.5 D, 2.5 D 4x4, 2.5 TD, 2.5 TD 4x4	ch.5616155→; not for special purpose vehicles;	<b>F8-8066</b>	
Top Strut Mounting	1.9 TD, 2.0, 2.5 D, 2.5 D 4x4, 2.5 TD, 2.5 TD 4x4	ch.→5616154; not for special purpose vehicles;	<b>F8-8067</b>	
Top Strut Mounting	1.9 TD, 2.0, 2.5 D, 2.5 D 4x4, 2.5 TD, 2.5 TD 4x4	ch.5616155→; not for special purpose vehicles;	<b>F8-8067</b>	
<b>DUCATO Bus (230)</b>			<b>03/1994 → 04/2002</b>	
Dust Cover Kit, shock absorber	1.9 D, 1.9 D Combinato, 1.9 TD, 1.9 TD Combinato, 1.9 TD Panorama/Combinato, 2.0 JTD, 2.0 Panorama/Combinato, 2.5 D Combinato, 2.5 TDI 4x4, 2.5 TDI Panorama/Combinato, 2.8 D, 2.8 JTD, 2.8 TDI 4x4, 2.8 TDI, 2.8 TDI 4x4		<b>AK-735070</b>	
Alternator Freewheel Clutch	2.0 JTD		<b>F5-1020</b>	
Alternator Freewheel Clutch	2.0 JTD		<b>F5-1046</b>	
Anti-Friction Bearing	1.9 D Combinato, 1.9 TD, 1.9 TD Panorama/Combinato, 2.0 Panorama/Combinato, 2.5 D Combinato, 2.5 TDI 4x4, 2.5 TDI Panorama/Combinato, 2.8 TDI		<b>F8-3013</b>	H=7; d=49; D=71

<b>AK-735070</b>	<b>F5-1020</b>	<b>F5-1046</b>	<b>F8-3013</b>	<b>F8-3023</b>	<b>F8-5084</b>	<b>F8-5353</b>
Ref.Nr.:	Ref.Nr.: 31771-68D01	Ref.Nr.: 30667687	Ref.Nr.: 503517	Ref.Nr.: 503547	Ref.Nr.: 3561.08	Ref.Nr.: 5038.19
<b>F8-5354</b>	<b>F8-5612</b>	<b>F8-5870</b>	<b>F8-5898</b>	<b>F8-6114</b>	<b>F8-6115</b>	<b>F8-6496</b>
Ref.Nr.: 5038.18	Ref.Nr.: 04466980	Ref.Nr.: 04333710	Ref.Nr.: 5131.73	Ref.Nr.: 1320755080-PA	Ref.Nr.: 3523.93	Ref.Nr.: 1844.41
<b>F8-6509</b>	<b>F8-6902</b>	<b>F8-6903</b>	<b>F8-6921</b>	<b>F8-8066</b>	<b>F8-8067</b>	
Ref.Nr.: 1843.61	Ref.Nr.: 7550024	Ref.Nr.: 5934176	Ref.Nr.: 1843.93	Ref.Nr.: 5038.72	Ref.Nr.: 5038.74	

Article Description



Article Nr.

Fitting Position



<b>DUCATO Bus (230)</b>			<b>03/1994 → 04/2002</b>		
Anti-Friction Bearing	1.9 D, 1.9 D Combinato, 1.9 TD, 1.9 TD Combinato, 1.9 TD Panorama/Combinato, 2.0 Panorama/Combinato, 2.5 D Combinato, 2.5 TDI 4x4, 2.5 TDI Panorama/Combinato, 2.8 D, 2.8 TDI		<b>F8-3023</b>		H=9; d=49; D=71
Tie Bar Bush	1.9 TD Panorama/Combinato, 2.0 Panorama/Combinato, 2.5 D Combinato, 2.5 TDI Panorama/Combinato		<b>F8-5084</b>		H=24.5; H1=20.5; d=22; D=48
Top Strut Mounting	1.9 D, 1.9 D Combinato, 1.9 TD, 1.9 TD Combinato, 1.9 TD Panorama/Combinato, 2.0, 2.0 4x4, 2.0 JTD, 2.0 Panorama/Combinato, 2.5 D Combinato, 2.5 TD, 2.5 TD 4x4, 2.5 TDI 4x4, 2.5 TDI Panorama/Combinato, 2.8 D, 2.8 JTD, 2.8 JTD 4x4, 2.8 TDI, 2.8 TDI 4x4	also for special vehicles;	<b>F8-5353</b>		
Top Strut Mounting	1.9 D, 1.9 D Combinato, 1.9 TD, 1.9 TD Combinato, 1.9 TD Panorama/Combinato, 2.0, 2.0 4x4, 2.0 JTD, 2.0 Panorama/Combinato, 2.5 D Combinato, 2.5 TD, 2.5 TD 4x4, 2.5 TDI 4x4, 2.5 TDI Panorama/Combinato, 2.8 D, 2.8 JTD, 2.8 JTD 4x4, 2.8 TDI, 2.8 TDI 4x4	also for special vehicles;	<b>F8-5354</b>		
Belt Pulley, crankshaft	1.9 D	D9B; Number of Ribs: 6;	<b>F8-5643</b>		Belt Pulley Ø [mm]=156; W=44
Belt Pulley, crankshaft	1.9 TD	Number of Ribs: 6;	<b>F8-5643</b>		Belt Pulley Ø [mm]=156; W=44
Mounting, leaf spring	1.9 TD Panorama/Combinato, 2.0 Panorama/Combinato, 2.5 TDI Panorama/Combinato		<b>F8-5870</b>		H=72; d=16; D=38
Mounting, leaf spring	1.9 D, 1.9 D Combinato, 1.9 TD, 1.9 TD Combinato, 1.9 TD Panorama/Combinato, 2.0, 2.0 4x4, 2.0 Panorama/Combinato, 2.5 D Combinato, 2.5 TD, 2.5 TD 4x4, 2.5 TDI 4x4, 2.5 TDI Panorama/Combinato, 2.8 D, 2.8 JTD, 2.8 JTD 4x4, 2.8 TDI, 2.8 TDI 4x4		<b>F8-5897</b>		H=46.5; d=16; D=40
Mounting, leaf spring	1.9 D, 1.9 D Combinato, 1.9 TD, 1.9 TD Combinato, 1.9 TD Panorama/Combinato, 2.0 JTD, 2.0 Panorama/Combinato, 2.5 D Combinato, 2.5 TDI 4x4, 2.5 TDI Panorama/Combinato, 2.8 D, 2.8 JTD, 2.8 JTD 4x4		<b>F8-5898</b>		H=87; d=16; D=50
Control Arm-/Trailing Arm Bush	1.9 D, 1.9 D Combinato, 1.9 TD, 1.9 TD Combinato, 1.9 TD Panorama/Combinato, 2.0, 2.0 4x4, 2.0 JTD, 2.0 Panorama/Combinato, 2.5 D Combinato, 2.5 TD, 2.5 TD 4x4, 2.5 TDI 4x4, 2.5 TDI Panorama/Combinato, 2.8 D, 2.8 JTD, 2.8 JTD 4x4, 2.8 TDI, 2.8 TDI 4x4	for OE: 1320755080, 1320756080, 3520.N3, 3520.N4, 3521.J3, 3521.J4	<b>F8-6114</b>		
Control Arm-/Trailing Arm Bush	1.9 D, 1.9 D Combinato, 1.9 TD, 1.9 TD Combinato, 1.9 TD Panorama/Combinato, 2.0, 2.0 4x4, 2.0 JTD, 2.0 Panorama/Combinato, 2.5 D Combinato, 2.5 TD, 2.5 TD 4x4, 2.5 TDI 4x4, 2.5 TDI Panorama/Combinato, 2.8 D, 2.8 JTD, 2.8 JTD 4x4, 2.8 TDI, 2.8 TDI 4x4		<b>F8-6115</b>		H=55; d=25.5; D1=56; D2=45

<b>F8-3023</b>	<b>F8-5084</b>	<b>F8-5353</b>	<b>F8-5354</b>	<b>F8-5643</b>	<b>F8-5870</b>	<b>F8-5897</b>
Ref.Nr.: 503547	Ref.Nr.: 3561.08	Ref.Nr.: 5038.19	Ref.Nr.: 5038.18	Ref.Nr.: 96089 38980	Ref.Nr.: 04333710	Ref.Nr.: 1304640080
<b>F8-5898</b>	<b>F8-6114</b>	<b>F8-6115</b>	<b>F8-6306</b>			
Ref.Nr.: 5131.73	Ref.Nr.: 1320755080-PA	Ref.Nr.: 3523.93	Ref.Nr.: 503547			

**Article Description****Article Nr.****Fitting Position**

<b>DUCATO Bus (230)</b>		<b>03/1994 → 04/2002</b>		
Top Strut Mounting	1.9 D, 1.9 D Combinato, 1.9 TD, 1.9 TD Combinato, 1.9 TD Panorama/Combinato, 2.0, 2.0 4x4, 2.0 JTD, 2.0 Panorama/Combinato, 2.5 D Combinato, 2.5 TD, 2.5 TD 4x4, 2.5 TDI 4x4, 2.5 TDI Panorama/Combinato, 2.8 D, 2.8 JTD, 2.8 JTD 4x4, 2.8 TDI, 2.8 TDI 4x4		<b>F8-6306</b>	
Control Arm-/Trailing Arm Bush	1.9 D, 1.9 D Combinato, 1.9 TD, 1.9 TD Combinato, 1.9 TD Panorama/Combinato, 2.0, 2.0 4x4, 2.0 JTD, 2.0 Panorama/Combinato, 2.5 D Combinato, 2.5 TD, 2.5 TD 4x4, 2.5 TDI 4x4, 2.5 TDI Panorama/Combinato, 2.8 D, 2.8 JTD, 2.8 JTD 4x4, 2.8 TDI, 2.8 TDI 4x4		<b>F8-6452</b>	
Engine Mounting	1.9 D		<b>F8-6485</b>	
Engine Mounting	1.9 D Combinato, 1.9 TD, 1.9 TD Combinato, 1.9 TD Panorama/Combinato, 2.0, 2.0 4x4, 2.0 JTD, 2.0 Panorama/Combinato, 2.5 D Combinato, 2.5 TD, 2.5 TD 4x4, 2.5 TDI 4x4, 2.5 TDI Panorama/Combinato, 2.8 D, 2.8 JTD, 2.8 JTD 4x4, 2.8 TDI, 2.8 TDI 4x4		<b>F8-6485</b>	
Engine Mounting	1.9 D, 1.9 D Combinato, 1.9 TD, 1.9 TD Combinato, 1.9 TD Panorama/Combinato, 2.0 Panorama/Combinato, 2.5 D Combinato, 2.5 TDI 4x4, 2.5 TDI Panorama/Combinato, 2.8 D, 2.8 TDI, 2.8 TDI 4x4		<b>F8-6520</b>	
Engine Mounting	2.5 D Combinato, 2.5 TDI 4x4, 2.5 TDI Panorama/Combinato, 2.8 D, 2.8 TDI, 2.8 TDI 4x4		<b>F8-6888</b>	
Engine Mounting	1.9 D		<b>F8-6891</b>	
Engine Mounting	1.9 D Combinato, 1.9 TD, 1.9 TD Combinato, 1.9 TD Panorama/Combinato, 2.0 Panorama/Combinato		<b>F8-6891</b>	
Engine Mounting	1.9 D		<b>F8-6918</b>	
Engine Mounting	1.9 D Combinato, 1.9 TD, 1.9 TD Combinato, 1.9 TD Panorama/Combinato, 2.0 JTD, 2.0 Panorama/Combinato, 2.5 D Combinato, 2.5 TDI 4x4, 2.5 TDI Panorama/Combinato, 2.8 D, 2.8 TDI, 2.8 TDI 4x4		<b>F8-6918</b>	
Engine Mounting	2.8 JTD, 2.8 JTD 4x4		<b>F8-6918</b>	
Belt Pulley, crankshaft	2.8 D	06/1998 →; Number of Ribs: 6	<b>F8-7080</b>	Belt Pulley Ø [mm]=146; Mounting points diam.[mm]=21; W=51.4
Belt Pulley, crankshaft	2.8 JTD, 2.8 JTD 4x4	Number of Ribs: 6	<b>F8-7080</b>	Belt Pulley Ø [mm]=146; Mounting points diam.[mm]=21; W=51.4
Belt Pulley, crankshaft	2.8 D, 2.8 JTD, 2.8 JTD 4x4	Number of Ribs: 6	<b>F8-7081</b>	Belt Pulley Ø [mm]=146; W=56

<b>F8-6306</b>	<b>F8-6452</b>	<b>F8-6485</b>	<b>F8-6520</b>	<b>F8-6888</b>	<b>F8-6891</b>	<b>F8-6918</b>
Ref.Nr.: 503547	Ref.Nr.: 3523.93	Ref.Nr.: 1846.66	Ref.Nr.: 1307908080	Ref.Nr.: 1307907080	Ref.Nr.: 1307906080	Ref.Nr.: 1310575080
<b>F8-7080</b>	<b>F8-7081</b>	<b>F8-7154</b>				
Ref.Nr.: 500332292	Ref.Nr.: 0515.T4	Ref.Nr.: 503530				

Article Description



Article Nr.

Fitting Position



<b>DUCATO Bus (230)</b>		<b>03/1994 → 04/2002</b>	
Top Strut Mounting	1.9 D, 1.9 D Combinato, 1.9 TD, 1.9 TD Combinato, 1.9 TD Panorama/Combinato, 2.0, 2.0 4x4, 2.0 JTD, 2.0 Panorama/Combinato, 2.5 D Combinato, 2.5 TD, 2.5 TD 4x4, 2.5 TDI 4x4, 2.5 TDI Panorama/Combinato, 2.8 D, 2.8 JTD, 2.8 JTD 4x4, 2.8 TDI, 2.8 TDI 4x4		<b>F8-7154</b>
Belt Pulley, crankshaft	1.9 D Combinato, 1.9 TD Combinato, 1.9 TD Panorama/Combinato		<b>F8-7863</b>
Belt Pulley, crankshaft	1.9 D, 1.9 TD		<b>F8-7863</b>
Top Strut Mounting	1.9 D, 1.9 D Combinato, 1.9 TD, 1.9 TD Combinato, 1.9 TD Panorama/Combinato, 2.0 4x4, 2.0 JTD, 2.0 Panorama/Combinato, 2.5 D Combinato, 2.5 TD, 2.5 TD 4x4, 2.5 TDI 4x4, 2.5 TDI Panorama/Combinato, 2.8 D, 2.8 JTD, 2.8 JTD 4x4, 2.8 TDI, 2.8 TDI 4x4	ch.→5616154; not for special purpose vehicles;	<b>F8-8066</b>
Top Strut Mounting	1.9 D, 1.9 D Combinato, 1.9 TD, 1.9 TD Combinato, 1.9 TD Panorama/Combinato, 2.0 4x4, 2.0 JTD, 2.0 Panorama/Combinato, 2.5 D Combinato, 2.5 TD, 2.5 TD 4x4, 2.5 TDI 4x4, 2.5 TDI Panorama/Combinato, 2.8 D, 2.8 JTD, 2.8 JTD 4x4, 2.8 TDI, 2.8 TDI 4x4	ch.5616155→; not for special purpose vehicles;	<b>F8-8066</b>
Top Strut Mounting	1.9 D, 1.9 D Combinato, 1.9 TD, 1.9 TD Combinato, 1.9 TD Panorama/Combinato, 2.0 4x4, 2.0 JTD, 2.0 Panorama/Combinato, 2.5 D Combinato, 2.5 TD, 2.5 TD 4x4, 2.5 TDI 4x4, 2.5 TDI Panorama/Combinato, 2.8 D, 2.8 JTD, 2.8 JTD 4x4, 2.8 TDI, 2.8 TDI 4x4	ch.→5616154; not for special purpose vehicles;	<b>F8-8067</b>
Top Strut Mounting	1.9 D, 1.9 D Combinato, 1.9 TD, 1.9 TD Combinato, 1.9 TD Panorama/Combinato, 2.0 4x4, 2.0 JTD, 2.0 Panorama/Combinato, 2.5 D Combinato, 2.5 TD, 2.5 TD 4x4, 2.5 TDI 4x4, 2.5 TDI Panorama/Combinato, 2.8 D, 2.8 JTD, 2.8 JTD 4x4, 2.8 TDI, 2.8 TDI 4x4	ch.5616155→; not for special purpose vehicles;	<b>F8-8067</b>
<b>DUCATO Box (230L)</b>		<b>03/1994 → 04/2002</b>	
Dust Cover Kit, shock absorber	1.9 D, 1.9 TD, 1.9 TD CAT, 2.0, 2.0 JTD, 2.5 D, 2.5 TDI, 2.5 TDI 4x4, 2.5 TDI Maxi, 2.8 D, 2.8 D 4x4, 2.8 JTD, 2.8 JTD 4x4, 2.8 TDI, 2.8 TDI 4x4	[kg]: 1000, 1400	<b>AK-735070</b>
Alternator Freewheel Clutch	2.0 JTD		<b>F5-1020</b>
Alternator Freewheel Clutch	2.0 JTD		<b>F5-1046</b>
Anti-Friction Bearing	1.9 D, 1.9 TD, 2.0, 2.5 D, 2.5 TDI, 2.5 TDI 4x4, 2.5 TDI Maxi, 2.8 TDI, 2.8 TDI 4x4		<b>F8-3013</b> H=7; d=49; D=71
Anti-Friction Bearing	1.9 D, 1.9 TD, 1.9 TD CAT, 2.0, 2.5 D, 2.5 TDI, 2.5 TDI 4x4, 2.5 TDI Maxi, 2.8 D, 2.8 TDI, 2.8 TDI 4x4		<b>F8-3023</b> H=9; d=49; D=71
Tie Bar Bush	1.9 D, 1.9 TD, 2.0, 2.5 D, 2.5 TDI, 2.5 TDI Maxi		<b>F8-5084</b> H=24.5; H1=20.5; d=22; D=48
Top Strut Mounting	1.9 D, 1.9 TD, 1.9 TD CAT, 2.0, 2.0 JTD, 2.5 D, 2.5 TD, 2.5 TD 4x4, 2.5 TDI, 2.5 TDI 4x4, 2.5 TDI Maxi, 2.8 D, 2.8 D 4x4, 2.8 iDTD 4x4, 2.8 JTD, 2.8 JTD 4x4, 2.8 TDI, 2.8 TDI 4x4	also for special vehicles;	<b>F8-5353</b>

<b>AK-735070</b>	<b>F5-1020</b>	<b>F5-1046</b>	<b>F8-3013</b>	<b>F8-3023</b>	<b>F8-5084</b>	<b>F8-5353</b>
Ref.Nr.:	Ref.Nr.: 31771-68D01	Ref.Nr.: 30667687	Ref.Nr.: 503517	Ref.Nr.: 503547	Ref.Nr.: 3561.08	Ref.Nr.: 5038.19
<b>F8-5354</b>	<b>F8-7154</b>	<b>F8-7863</b>	<b>F8-8066</b>	<b>F8-8067</b>		
Ref.Nr.: 5038.18	Ref.Nr.: 503530	Ref.Nr.: 0515K4	Ref.Nr.: 5038.72	Ref.Nr.: 5038.74		

**Article Description****Article Nr.****Fitting Position**

<b>DUCATO Box (230L)</b>			<b>03/1994 → 04/2002</b>		
Top Strut Mounting	1.9 D, 1.9 TD, 1.9 TD CAT, 2.0, 2.0 JTD, 2.5 D, 2.5 TD, 2.5 TD 4x4, 2.5 TDI, 2.5 TDI 4x4, 2.5 TDI Maxi, 2.8 D, 2.8 D 4x4, 2.8 iDTD 4x4, 2.8 JTD, 2.8 JTD 4x4, 2.8 TDI, 2.8 TDI 4x4	also for special vehicles;	<b>F8-5354</b>		
Belt Pulley, crankshaft	2.0 JTD		<b>F8-5636</b>		d=30
Belt Pulley, crankshaft	1.9 D, 1.9 TD	Number of Ribs: 6;	<b>F8-5643</b>		Belt Pulley Ø [mm]=156; W=44
Mounting, leaf spring	1.9 D, 1.9 TD, 2.0, 2.5 D, 2.5 TDI Maxi		<b>F8-5870</b>		H=72; d=16; D=38
Mounting, leaf spring	1.9 D, 1.9 TD, 1.9 TD CAT, 2.0, 2.5 D, 2.5 TD, 2.5 TD 4x4, 2.5 TDI, 2.5 TDI 4x4, 2.5 TDI Maxi, 2.8 D, 2.8 D 4x4, 2.8 iDTD 4x4, 2.8 JTD, 2.8 JTD 4x4, 2.8 TDI		<b>F8-5897</b>		H=46.5; d=16; D=40
Mounting, leaf spring	1.9 D, 1.9 TD, 1.9 TD CAT, 2.0, 2.0 JTD, 2.5 D, 2.5 TDI, 2.5 TDI 4x4, 2.5 TDI Maxi, 2.8 D, 2.8 D 4x4, 2.8 JTD, 2.8 JTD 4x4, 2.8 TDI, 2.8 TDI 4x4		<b>F8-5898</b>		H=87; d=16; D=50
Control Arm-/Trailing Arm Bush	1.9 D, 1.9 TD, 1.9 TD CAT, 2.0, 2.0 4x4, 2.0 JTD, 2.5 D, 2.5 TD, 2.5 TD 4x4, 2.5 TDI, 2.5 TDI 4x4, 2.5 TDI Maxi, 2.8 D, 2.8 D 4x4, 2.8 iDTD 4x4, 2.8 JTD, 2.8 JTD 4x4, 2.8 TDI, 2.8 TDI 4x4	for OE: 1320755080, 1320756080, 3520.N3, 3520.N4, 3521.J3, 3521.J4	<b>F8-6114</b>		
Control Arm-/Trailing Arm Bush	1.9 D, 1.9 TD, 1.9 TD CAT, 2.0, 2.0 JTD, 2.5 D, 2.5 TD, 2.5 TD 4x4, 2.5 TDI, 2.5 TDI 4x4, 2.5 TDI Maxi, 2.8 D, 2.8 D 4x4, 2.8 iDTD 4x4, 2.8 JTD, 2.8 JTD 4x4, 2.8 TDI, 2.8 TDI 4x4		<b>F8-6115</b>		H=55; d=25.5; D1=56; D2=45
Top Strut Mounting	1.9 D, 1.9 TD, 1.9 TD CAT, 2.0, 2.0 4x4, 2.0 JTD, 2.5 D, 2.5 TD, 2.5 TD 4x4, 2.5 TDI, 2.5 TDI 4x4, 2.5 TDI Maxi, 2.8 D, 2.8 D 4x4, 2.8 iDTD 4x4, 2.8 JTD, 2.8 JTD 4x4, 2.8 TDI, 2.8 TDI 4x4		<b>F8-6306</b>		
Control Arm-/Trailing Arm Bush	1.9 D, 1.9 TD, 1.9 TD CAT, 2.0, 2.0 JTD, 2.5 D, 2.5 TD, 2.5 TD 4x4, 2.5 TDI, 2.5 TDI 4x4, 2.5 TDI Maxi, 2.8 D, 2.8 D 4x4, 2.8 iDTD 4x4, 2.8 JTD, 2.8 JTD 4x4, 2.8 TDI, 2.8 TDI 4x4		<b>F8-6452</b>		
Engine Mounting	1.9 D, 1.9 TD, 1.9 TD CAT, 2.0, 2.0 JTD, 2.5 D, 2.5 TD, 2.5 TD 4x4, 2.5 TDI, 2.5 TDI 4x4, 2.5 TDI Maxi, 2.8 D, 2.8 D 4x4, 2.8 iDTD 4x4, 2.8 JTD, 2.8 JTD 4x4, 2.8 TDI, 2.8 TDI 4x4		<b>F8-6485</b>		
Engine Mounting	1.9 D, 1.9 TD, 1.9 TD CAT, 2.0, 2.5 D, 2.5 TDI, 2.5 TDI 4x4, 2.5 TDI Maxi, 2.8 D, 2.8 D 4x4, 2.8 TDI, 2.8 TDI 4x4	[kg]: 1800	<b>F8-6520</b>		
Engine Mounting	2.5 D, 2.5 TDI, 2.5 TDI 4x4, 2.5 TDI Maxi, 2.8 D, 2.8 D 4x4, 2.8 TDI, 2.8 TDI 4x4		<b>F8-6888</b>		
Engine Mounting	1.9 D, 1.9 TD, 1.9 TD CAT, 2.0		<b>F8-6891</b>		
Engine Mounting	1.9 D, 1.9 TD, 1.9 TD CAT, 2.0, 2.0 JTD, 2.5 D, 2.5 TDI, 2.5 TDI 4x4, 2.5 TDI Maxi, 2.8 D, 2.8 D 4x4, 2.8 TDI, 2.8 TDI 4x4		<b>F8-6918</b>		
Engine Mounting	2.8 JTD, 2.8 JTD 4x4		<b>F8-6918</b>		
Belt Pulley, crankshaft	2.8 D	06/1998 →; Number of Ribs: 6	<b>F8-7080</b>		Belt Pulley Ø [mm]=146; Mounting points diam.[mm]=21; W=51.4

<b>F8-5354</b>	<b>F8-5636</b>	<b>F8-5643</b>	<b>F8-5870</b>	<b>F8-5897</b>	<b>F8-5898</b>	<b>F8-6114</b>
Ref.Nr.: 5038.18	Ref.Nr.: 0515P2	Ref.Nr.: 96089 38980	Ref.Nr.: 04333710	Ref.Nr.: 1304640080	Ref.Nr.: 5131.73	Ref.Nr.: 1320755080-PA
<b>F8-6115</b>	<b>F8-6306</b>	<b>F8-6452</b>	<b>F8-6485</b>	<b>F8-6520</b>	<b>F8-6888</b>	<b>F8-6891</b>
Ref.Nr.: 3523.93	Ref.Nr.: 503547	Ref.Nr.: 3523.93	Ref.Nr.: 1846.66	Ref.Nr.: 1307908080	Ref.Nr.: 1307907080	Ref.Nr.: 1307906080
<b>F8-6918</b>	<b>F8-7080</b>					
Ref.Nr.: 1310575080	Ref.Nr.: 500332292					

Article Description

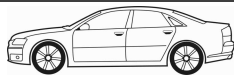

Article Nr.

Fitting Position



<b>DUCATO Box (230L)</b>				<b>03/1994 → 04/2002</b>	
Belt Pulley, crankshaft	2.8 D 4x4, 2.8 JTD, 2.8 JTD 4x4	Number of Ribs: 6	<b>F8-7080</b>		Belt Pulley Ø [mm]=146; Mounting points diam.[mm]=21; W=51.4
Belt Pulley, crankshaft	2.8 D, 2.8 D 4x4, 2.8 JTD	Number of Ribs: 6	<b>F8-7081</b>		Belt Pulley Ø [mm]=146; W=56
Top Strut Mounting	1.9 D, 1.9 TD, 1.9 TD CAT, 2.0, 2.0 4x4, 2.0 JTD, 2.5 D, 2.5 TD, 2.5 TD 4x4, 2.5 TDI, 2.5 TDI 4x4, 2.5 TDI Maxi, 2.8 D, 2.8 D 4x4, 2.8 iDTD 4x4, 2.8 JTD, 2.8 JTD 4x4, 2.8 TDI, 2.8 TDI 4x4		<b>F8-7154</b>		
Belt Pulley, crankshaft	1.9 D	11/1994 →	<b>F8-7863</b>		
Belt Pulley, crankshaft	1.9 D, 1.9 TD		<b>F8-7863</b>		
Belt Pulley, crankshaft	1.9 TD	06/1994 →	<b>F8-7863</b>		
Belt Pulley, crankshaft	1.9 TD CAT		<b>F8-7863</b>		
Top Strut Mounting	1.9 D, 1.9 TD, 1.9 TD CAT, 2.0, 2.0 JTD, 2.5 D, 2.5 TD, 2.5 TD 4x4, 2.5 TDI, 2.5 TDI 4x4, 2.5 TDI Maxi, 2.8 D, 2.8 D 4x4, 2.8 iDTD 4x4, 2.8 JTD, 2.8 JTD 4x4, 2.8 TDI, 2.8 TDI 4x4	ch.→5616154; not for special purpose vehicles;	<b>F8-8066</b>		
Top Strut Mounting	1.9 D, 1.9 TD, 1.9 TD CAT, 2.0, 2.0 JTD, 2.5 D, 2.5 TD, 2.5 TD 4x4, 2.5 TDI, 2.5 TDI 4x4, 2.5 TDI Maxi, 2.8 D, 2.8 D 4x4, 2.8 iDTD 4x4, 2.8 JTD, 2.8 JTD 4x4, 2.8 TDI, 2.8 TDI 4x4	ch.5616155→; not for special purpose vehicles;	<b>F8-8066</b>		
Top Strut Mounting	1.9 D, 1.9 TD, 1.9 TD CAT, 2.0, 2.0 JTD, 2.5 D, 2.5 TD, 2.5 TD 4x4, 2.5 TDI, 2.5 TDI 4x4, 2.5 TDI Maxi, 2.8 D, 2.8 D 4x4, 2.8 iDTD 4x4, 2.8 JTD, 2.8 JTD 4x4, 2.8 TDI, 2.8 TDI 4x4	ch.→5616154; not for special purpose vehicles;	<b>F8-8067</b>		
Top Strut Mounting	1.9 D, 1.9 TD, 1.9 TD CAT, 2.0, 2.0 JTD, 2.5 D, 2.5 TD, 2.5 TD 4x4, 2.5 TDI, 2.5 TDI 4x4, 2.5 TDI Maxi, 2.8 D, 2.8 D 4x4, 2.8 iDTD 4x4, 2.8 JTD, 2.8 JTD 4x4, 2.8 TDI, 2.8 TDI 4x4	ch.5616155→; not for special purpose vehicles;	<b>F8-8067</b>		

<b>DUCATO Platform/Chassis (230)</b>				<b>03/1994 → 04/2002</b>	
Dust Cover Kit, shock absorber	1.9 D, 1.9 TD, 1.9 TD CAT, 2.0, 2.5 D, 2.5 D 4x4, 2.5 TDI, 2.5 TDI 4x4, 2.8 D, 2.8 JTD, 2.8 TDI	[kg]: 1000, 1400	<b>AK-735070</b>		
Anti-Friction Bearing	1.9 D, 1.9 TD, 2.0, 2.5 D, 2.5 D 4x4, 2.5 TDI, 2.5 TDI 4x4, 2.8 TDI		<b>F8-3013</b>		H=7; d=49; D=71
Anti-Friction Bearing	1.9 D, 1.9 TD, 1.9 TD CAT, 2.0, 2.5 D, 2.5 TDI, 2.8 D, 2.8 TDI		<b>F8-3023</b>		H=9; d=49; D=71
Tie Bar Bush	1.9 D, 1.9 TD, 2.5 D, 2.5 TDI		<b>F8-5084</b>		H=24.5; H1=20.5; d=22; D=48
Top Strut Mounting	1.9 D, 1.9 TD, 1.9 TD CAT, 2.0, 2.5 D, 2.5 D 4x4, 2.5 TD, 2.5 TD 4x4, 2.5 TDI, 2.5 TDI 4x4, 2.8 D, 2.8 iDTD 4x4, 2.8 JTD, 2.8 TD 4x4, 2.8 TDI	also for special vehicles;	<b>F8-5353</b>		
Top Strut Mounting	1.9 D, 1.9 TD, 1.9 TD CAT, 2.0, 2.5 D, 2.5 D 4x4, 2.5 TD, 2.5 TD 4x4, 2.5 TDI, 2.5 TDI 4x4, 2.8 D, 2.8 iDTD 4x4, 2.8 JTD, 2.8 TD 4x4, 2.8 TDI	also for special vehicles;	<b>F8-5354</b>		
Belt Pulley, crankshaft	1.9 D, 1.9 TD	Number of Ribs: 6;	<b>F8-5643</b>		Belt Pulley Ø [mm]=156; W=44
Mounting, leaf spring	1.9 D, 1.9 TD, 2.5 D, 2.5 TDI		<b>F8-5870</b>		H=72; d=16; D=38

<b>AK-735070</b>	<b>F8-3013</b>	<b>F8-3023</b>	<b>F8-5084</b>	<b>F8-5353</b>	<b>F8-5354</b>	<b>F8-5643</b>
Ref.Nr.: <b>AK-735070</b>	Ref.Nr.: <b>503517</b>	Ref.Nr.: <b>503547</b>	Ref.Nr.: <b>3561.08</b>	Ref.Nr.: <b>5038.19</b>	Ref.Nr.: <b>5038.18</b>	Ref.Nr.: <b>96089 38980</b>
<b>F8-5870</b>	<b>F8-5897</b>	<b>F8-7080</b>	<b>F8-7081</b>	<b>F8-7154</b>	<b>F8-7863</b>	<b>F8-8066</b>
Ref.Nr.: <b>04333710</b>	Ref.Nr.: <b>1304640080</b>	Ref.Nr.: <b>500332292</b>	Ref.Nr.: <b>0515.T4</b>	Ref.Nr.: <b>503530</b>	Ref.Nr.: <b>0515K4</b>	Ref.Nr.: <b>5038.72</b>
<b>F8-8067</b>						
Ref.Nr.: <b>5038.74</b>						



**Article Description****Article Nr.****Fitting Position**

<b>DUCATO Platform/Chassis (230)</b>			<b>03/1994 → 04/2002</b>	
Mounting, leaf spring	1.9 D, 1.9 TD, 1.9 TD CAT, 2.0, 2.5 D, 2.5 D 4x4, 2.5 TD, 2.5 TD 4x4, 2.5 TDI, 2.8 D, 2.8 iDTD 4x4, 2.8 JTD, 2.8 TD 4x4, 2.8 TDI		<b>F8-5897</b>	⊕ ⊕ H=46.5; d=16; D=40
Mounting, leaf spring	1.9 D, 1.9 TD, 1.9 TD CAT, 2.0, 2.5 D, 2.5 D 4x4, 2.5 TDI, 2.5 TDI 4x4, 2.8 D, 2.8 JTD, 2.8 TDI		<b>F8-5898</b>	⊕ ⊕ H=87; d=16; D=50
Control Arm-/Trailing Arm Bush	1.9 D, 1.9 TD, 1.9 TD CAT, 2.0, 2.5 D, 2.5 D 4x4, 2.5 TD, 2.5 TD 4x4, 2.5 TDI, 2.5 TDI 4x4, 2.8 D, 2.8 iDTD 4x4, 2.8 JTD, 2.8 TD 4x4, 2.8 TDI	for OE: 1320755080, 1320756080, 3520.N3, 3520.N4, 3521.J3, 3521.J4	<b>F8-6114</b>	⊕ ⊕ ⊕ ↓
Control Arm-/Trailing Arm Bush	1.9 D, 1.9 TD, 1.9 TD CAT, 2.0, 2.5 D, 2.5 D 4x4, 2.5 TD, 2.5 TD 4x4, 2.5 TDI, 2.5 TDI 4x4, 2.8 D, 2.8 iDTD 4x4, 2.8 JTD, 2.8 TD 4x4, 2.8 TDI		<b>F8-6115</b>	⊕ ⊕ ⊕ H=55; d=25.5; D1=56; D2=45
Top Strut Mounting	1.9 D, 1.9 TD, 1.9 TD CAT, 2.0, 2.5 D, 2.5 D 4x4, 2.5 TD, 2.5 TD 4x4, 2.5 TDI, 2.5 TDI 4x4, 2.8 D, 2.8 iDTD 4x4, 2.8 JTD, 2.8 TD 4x4, 2.8 TDI		<b>F8-6306</b>	⊕
Control Arm-/Trailing Arm Bush	1.9 D, 1.9 TD, 1.9 TD CAT, 2.0, 2.5 D, 2.5 D 4x4, 2.5 TD, 2.5 TD 4x4, 2.5 TDI, 2.5 TDI 4x4, 2.8 D, 2.8 iDTD 4x4, 2.8 JTD, 2.8 TD 4x4, 2.8 TDI		<b>F8-6452</b>	⊕ ⊕ ⊕ ↓
Engine Mounting	1.9 D, 1.9 TD, 1.9 TD CAT, 2.0, 2.5 D, 2.5 D 4x4, 2.5 TD, 2.5 TD 4x4, 2.5 TDI, 2.5 TDI 4x4, 2.8 D, 2.8 iDTD 4x4, 2.8 JTD, 2.8 TDI		<b>F8-6485</b>	⊕
Engine Mounting	1.9 D, 1.9 TD, 1.9 TD CAT, 2.0, 2.5 D, 2.5 D 4x4, 2.5 TDI, 2.5 TDI 4x4, 2.8 D, 2.8 TDI	[kg]: 1800	<b>F8-6520</b>	
Engine Mounting	2.5 D, 2.5 D 4x4, 2.5 TDI, 2.5 TDI 4x4, 2.8 D, 2.8 TDI		<b>F8-6888</b>	⊕
Engine Mounting	1.9 D, 1.9 TD, 1.9 TD CAT, 2.0		<b>F8-6891</b>	⊕
Engine Mounting	1.9 D, 1.9 TD, 1.9 TD CAT, 2.0, 2.5 D, 2.5 D 4x4, 2.5 TDI, 2.5 TDI 4x4, 2.8 D, 2.8 TDI		<b>F8-6918</b>	⊕
Engine Mounting	2.8 JTD		<b>F8-6918</b>	⊕
Belt Pulley, crankshaft	2.8 D	06/1998 →; Number of Ribs: 6	<b>F8-7080</b>	
Belt Pulley, crankshaft	2.8 JTD	Number of Ribs: 6	<b>F8-7080</b>	
Belt Pulley, crankshaft	2.8 D, 2.8 JTD	Number of Ribs: 6	<b>F8-7081</b>	
Top Strut Mounting	1.9 D, 1.9 TD, 1.9 TD CAT, 2.0, 2.5 D, 2.5 D 4x4, 2.5 TD, 2.5 TD 4x4, 2.5 TDI, 2.5 TDI 4x4, 2.8 D, 2.8 iDTD 4x4, 2.8 JTD, 2.8 TD 4x4, 2.8 TDI		<b>F8-7154</b>	⊕
Belt Pulley, crankshaft	1.9 D, 1.9 TD	11/1994 →	<b>F8-7863</b>	
Belt Pulley, crankshaft	1.9 D, 1.9 TD		<b>F8-7863</b>	
Belt Pulley, crankshaft	1.9 TD CAT		<b>F8-7863</b>	
Top Strut Mounting	1.9 D, 1.9 TD, 1.9 TD CAT, 2.0, 2.5 D, 2.5 D 4x4, 2.5 TD, 2.5 TD 4x4, 2.5 TDI, 2.5 TDI 4x4, 2.8 D, 2.8 iDTD 4x4, 2.8 JTD, 2.8 TD 4x4, 2.8 TDI	ch.→5616154; not for special purpose vehicles;	<b>F8-8066</b>	⊕

<b>F8-5897</b>	<b>F8-5898</b>	<b>F8-6114</b>	<b>F8-6115</b>	<b>F8-6306</b>	<b>F8-6452</b>	<b>F8-6485</b>
Ref.Nr.: 1304640080	Ref.Nr.: 5131.73	Ref.Nr.: 1320755080-PA	Ref.Nr.: 3523.93	Ref.Nr.: 503547	Ref.Nr.: 3523.93	Ref.Nr.: 1846.66
<b>F8-6520</b>	<b>F8-6888</b>	<b>F8-6891</b>	<b>F8-6918</b>	<b>F8-7080</b>	<b>F8-7081</b>	<b>F8-7154</b>
Ref.Nr.: 1307908080	Ref.Nr.: 1307907080	Ref.Nr.: 1307906080	Ref.Nr.: 1310575080	Ref.Nr.: 500332292	Ref.Nr.: 0515.T4	Ref.Nr.: 503530
<b>F8-7863</b>	<b>F8-8066</b>					
Ref.Nr.: 0515K4	Ref.Nr.: 5038.72					

Article Description



Article Nr.

Fitting Position



<b>DUCATO Platform/Chassis (230)</b>			<b>03/1994 → 04/2002</b>		
Top Strut Mounting	1.9 D, 1.9 TD, 1.9 TD CAT, 2.0, 2.5 D, 2.5 D 4x4, 2.5 TD, 2.5 TD 4x4, 2.5 TDI, 2.5 TDI 4x4, 2.8 D, 2.8 IDTD 4x4, 2.8 JTD, 2.8 TD 4x4, 2.8 TDI	ch.5616155→; not for special purpose vehicles;	<b>F8-8066</b>		
Top Strut Mounting	1.9 D, 1.9 TD, 1.9 TD CAT, 2.0, 2.5 D, 2.5 D 4x4, 2.5 TD, 2.5 TD 4x4, 2.5 TDI, 2.5 TDI 4x4, 2.8 D, 2.8 IDTD 4x4, 2.8 JTD, 2.8 TD 4x4, 2.8 TDI	ch.→5616154; not for special purpose vehicles;	<b>F8-8067</b>		
Top Strut Mounting	1.9 D, 1.9 TD, 1.9 TD CAT, 2.0, 2.5 D, 2.5 D 4x4, 2.5 TD, 2.5 TD 4x4, 2.5 TDI, 2.5 TDI 4x4, 2.8 D, 2.8 IDTD 4x4, 2.8 JTD, 2.8 TD 4x4, 2.8 TDI	ch.5616155→; not for special purpose vehicles;	<b>F8-8067</b>		
<b>DUCATO Bus (244, Z_)</b>			<b>04/2002 → 07/2006</b>		
Dust Cover Kit, shock absorber	2.0, 2.0 Bipower, 2.0 JTD, 2.3 JTD, 2.8 JTD, 2.8 JTD 4x4		<b>AK-735070</b>		
Alternator Freewheel Clutch	2.3 JTD		<b>F5-1013</b>		
Alternator Freewheel Clutch	2.0 JTD, 2.3 JTD		<b>F5-1020</b>		
Alternator Freewheel Clutch	2.0 JTD		<b>F5-1046</b>		
Belt Pulley, crankshaft	2.0 JTD		<b>F8-5636</b>		d=30
Mounting, leaf spring	All Models		<b>F8-5897</b>		H=46.5; d=16; D=40
Control Arm-/Trailing Arm Bush	All Models	ch.→17226522; for OE: 1320755080, 1320756080, 3520.N3, 3520.N4, 3521.J3, 3521.J4	<b>F8-6114</b>		
Control Arm-/Trailing Arm Bush	2.0, 2.0 Bipower, 2.0 JTD, 2.3 JTD, 2.8 JTD, 2.8 JTD 4x4		<b>F8-6115</b>		H=55; d=25.5; D1=56; D2=45
Control Arm-/Trailing Arm Bush	All Models		<b>F8-6452</b>		
Engine Mounting	2.0, 2.0 4x4, 2.0 Bipower, 2.0 JTD, 2.3 JTD, 2.8 JTD, 2.8 JTD 4x4		<b>F8-6485</b>		
Control Arm-/Trailing Arm Bush	All Models	ch.17226523→; for OE: 3520.N3, 3520.N4, 3521.J3, 3521.J4	<b>F8-6773</b>		
Engine Mounting	2.0, 2.0 JTD		<b>F8-6918</b>		
Belt Pulley, crankshaft	2.8 JTD, 2.8 JTD 4x4	Number of Ribs: 6	<b>F8-7080</b>		Belt Pulley Ø [mm]=146; Mounting points diam.[mm]=21; W=51.4
Belt Pulley, crankshaft	2.8 JTD, 2.8 JTD 4x4	Number of Ribs: 6	<b>F8-7081</b>		Belt Pulley Ø [mm]=146; W=56
<b>DUCATO Box (244)</b>			<b>04/2002 → 07/2006</b>		
Dust Cover Kit, shock absorber	2.0, 2.0 Bipower, 2.0 JTD, 2.3 JTD, 2.8 JTD, 2.8 JTD 4x4	[kg]: 1000, 1400	<b>AK-735070</b>		
Alternator Freewheel Clutch	2.3 JTD		<b>F5-1013</b>		
Alternator Freewheel Clutch	2.0 JTD, 2.3 JTD		<b>F5-1020</b>		
Alternator Freewheel Clutch	2.0 JTD		<b>F5-1046</b>		
Belt Pulley, crankshaft	2.0 JTD		<b>F8-5636</b>		d=30
Mounting, leaf spring	All Models		<b>F8-5897</b>		H=46.5; d=16; D=40

<b>AK-735070</b>	<b>F5-1013</b>	<b>F5-1020</b>	<b>F5-1046</b>	<b>F8-5636</b>	<b>F8-5897</b>	<b>F8-6114</b>
Ref.Nr.: <b>5038.72</b>	Ref.Nr.: <b>038903119L</b>	Ref.Nr.: <b>31771-68D01</b>	Ref.Nr.: <b>30667687</b>	Ref.Nr.: <b>0515P2</b>	Ref.Nr.: <b>1304640080</b>	Ref.Nr.: <b>1320755080-PA</b>
<b>F8-6115</b>	<b>F8-6452</b>	<b>F8-6485</b>	<b>F8-6773</b>	<b>F8-6918</b>	<b>F8-7080</b>	<b>F8-7081</b>
Ref.Nr.: <b>3523.93</b>	Ref.Nr.: <b>3523.93</b>	Ref.Nr.: <b>1846.66</b>	Ref.Nr.: <b>1338373080</b>	Ref.Nr.: <b>1310575080</b>	Ref.Nr.: <b>500332292</b>	Ref.Nr.: <b>0515.T4</b>
<b>F8-8066</b>	<b>F8-8067</b>					
Ref.Nr.: <b>5038.72</b>	Ref.Nr.: <b>5038.74</b>					

**Article Description****Article Nr.****Fitting Position****DUCATO Box (244)**

04/2002 → 07/2006

Control Arm-/Trailing Arm Bush	All Models	ch.→17226522; for OE: 1320755080, 1320756080, 3520.N3, 3520.N4, 3521.J3, 3521.J4	<b>F8-6114</b>		
Control Arm-/Trailing Arm Bush	2.0, 2.0 Bipower, 2.0 JTD, 2.3 JTD, 2.8 JTD, 2.8 JTD 4x4		<b>F8-6115</b>		H=55; d=25.5; D1=56; D2=45
Top Strut Mounting	2.0, 2.0 Bipower, 2.0 JTD, 2.3 JTD, 2.8 JTD, 2.8 JTD 4x4, 2.8 JTD Power		<b>F8-6306</b>		
Control Arm-/Trailing Arm Bush	All Models		<b>F8-6452</b>		
Engine Mounting	2.0, 2.0 4x4, 2.0 Bipower, 2.0 JTD, 2.3 JTD, 2.8 JTD, 2.8 JTD 4x4		<b>F8-6485</b>		
Control Arm-/Trailing Arm Bush	All Models	ch.17226523→; for OE: 3520.N3, 3520.N4, 3521.J3, 3521.J4	<b>F8-6773</b>		
Engine Mounting	2.0, 2.0 JTD		<b>F8-6918</b>		
Belt Pulley, crankshaft	2.8 JTD, 2.8 JTD 4x4, 2.8 JTD Power	Number of Ribs: 6	<b>F8-7080</b>		Belt Pulley Ø [mm]=146; Mounting points diam.[mm]=21; W=51.4
Belt Pulley, crankshaft	2.8 JTD, 2.8 JTD 4x4	Number of Ribs: 6	<b>F8-7081</b>		Belt Pulley Ø [mm]=146; W=56
Top Strut Mounting	2.0, 2.0 Bipower, 2.0 JTD, 2.3 JTD, 2.8 JTD, 2.8 JTD 4x4, 2.8 JTD Power		<b>F8-7154</b>		

**DUCATO Platform/Chassis (244)**

04/2002 → 07/2006

Dust Cover Kit, shock absorber	2.0 JTD, 2.3 JTD, 2.8 JTD, 2.8 JTD 4x4	[kg]: 1000, 1400	<b>AK-735070</b>		
Alternator Freewheel Clutch	2.3 JTD		<b>F5-1013</b>		
Alternator Freewheel Clutch	2.0 JTD, 2.3 JTD		<b>F5-1020</b>		
Alternator Freewheel Clutch	2.0 JTD		<b>F5-1046</b>		
Belt Pulley, crankshaft	2.0 JTD		<b>F8-5636</b>		d=30
Mounting, leaf spring	All Models		<b>F8-5897</b>		H=46.5; d=16; D=40
Control Arm-/Trailing Arm Bush	2.0 JTD, 2.3 JTD, 2.8 JTD, 2.8 JTD 4x4, 2.8 JTD Power	ch.→17226522; for OE: 1320755080, 1320756080, 3520.N3, 3520.N4, 3521.J3, 3521.J4	<b>F8-6114</b>		
Control Arm-/Trailing Arm Bush	2.0 JTD, 2.3 JTD, 2.8 JTD, 2.8 JTD 4x4		<b>F8-6115</b>		H=55; d=25.5; D1=56; D2=45
Top Strut Mounting	2.0 JTD, 2.3 JTD, 2.8 JTD, 2.8 JTD 4x4, 2.8 JTD Power		<b>F8-6306</b>		
Control Arm-/Trailing Arm Bush	2.0 JTD, 2.3 JTD, 2.8 JTD, 2.8 JTD 4x4, 2.8 JTD Power		<b>F8-6452</b>		
Engine Mounting	2.0 JTD, 2.3 JTD, 2.8 JTD, 2.8 JTD 4x4		<b>F8-6485</b>		
Control Arm-/Trailing Arm Bush	2.0 JTD, 2.3 JTD, 2.8 JTD, 2.8 JTD 4x4, 2.8 JTD Power	ch.17226523→; for OE: 3520.N3, 3520.N4, 3521.J3, 3521.J4	<b>F8-6773</b>		
Engine Mounting	2.0 JTD		<b>F8-6918</b>		

<b>AK-735070</b>	<b>F5-1013</b>	<b>F5-1020</b>	<b>F5-1046</b>	<b>F8-5636</b>	<b>F8-5897</b>	<b>F8-6114</b>
Ref.Nr.:	Ref.Nr.: 038903119L	Ref.Nr.: 31771-68D01	Ref.Nr.: 30667687	Ref.Nr.: 0515P2	Ref.Nr.: 1304640080	Ref.Nr.: 1320755080-PA
<b>F8-6115</b>	<b>F8-6306</b>	<b>F8-6452</b>	<b>F8-6485</b>	<b>F8-6773</b>	<b>F8-6918</b>	<b>F8-7080</b>
Ref.Nr.: 3523.93	Ref.Nr.: 503547	Ref.Nr.: 3523.93	Ref.Nr.: 1846.66	Ref.Nr.: 1338373080	Ref.Nr.: 1310575080	Ref.Nr.: 500332292
<b>F8-7081</b>	<b>F8-7154</b>					
Ref.Nr.: 0515.T4	Ref.Nr.: 503530					

Article Description



Article Nr.

Fitting Position



**DUCATO Platform/Chassis (244)**

04/2002 → 07/2006

Belt Pulley, crankshaft	2.8 JTD 4x4, 2.8 JTD Power	Number of Ribs: 6	F8-7080		Belt Pulley Ø [mm]=146; Mounting points diam.[mm]=21; W=51.4
Belt Pulley, crankshaft	2.8 JTD, 2.8 JTD 4x4	Number of Ribs: 6	F8-7081		Belt Pulley Ø [mm]=146; W=56
Top Strut Mounting	2.0 JTD, 2.3 JTD, 2.8 JTD, 2.8 JTD 4x4, 2.8 JTD Power		F8-7154		

**DUCATO Bus (250, 290)**

07/2006 →

Alternator Freewheel Clutch	130 Multijet 2,3 D		F5-1013		
Alternator Freewheel Clutch	100 Multijet 2,2 D		F5-1046		
Alternator Freewheel Clutch	115 Multijet 2,0 D		F5-1072		
Alternator Freewheel Clutch	115 Multijet 2,0 D		F5-1098		
Alternator Freewheel Clutch	100 Multijet 2,2 D		F5-1125		
Alternator Freewheel Clutch	140 Natural Power, 150 Multijet 3,0 D, 160 Multijet 3,0 D, 3,0 D Multijet		F5-1148		
Top Strut Mounting	100 Multijet 2,2 D, 120 Multijet 2,3 D, 160 Multijet 3,0 D		F8-6610		
Top Strut Mounting	100 Multijet 2,2 D, 120 Multijet 2,3 D, 160 Multijet 3,0 D		F8-6611		
Engine Mounting	100 Multijet 2,2 D		F8-6612		
Engine Mounting	120 Multijet 2,3 D, 130 Multijet 2,3 D, 150 Multijet 2,3 D	not for transmission type: M38	F8-6612		
Engine Mounting	160 Multijet 3,0 D		F8-6613		
Engine Mounting	100 Multijet 2,2 D, 120 Multijet 2,3 D, 140 Natural Power		F8-6614		
Mounting, manual transmission	100 Multijet 2,2 D, 120 Multijet 2,3 D, 150 Multijet 3,0 D, 160 Multijet 3,0 D		F8-6712		
Top Strut Mounting	100 Multijet 2,2 D, 120 Multijet 2,3 D, 160 Multijet 3,0 D		F8-7467		
Top Strut Mounting	100 Multijet 2,2 D, 120 Multijet 2,3 D, 160 Multijet 3,0 D		F8-7468		
Mounting, leaf spring	100 Multijet 2,2 D, 110 Multijet 2,3 D, 115 Multijet 2,0 D, 120 Multijet 2,3 D, 130 Multijet 2,3 D, 140 Natural Power, 150 Multijet 2,3 D, 150 Multijet 3,0 D, 160 Multijet 3,0 D, 3,0 D Multijet		F8-7790		H=43; d=28; D=50
Mounting, leaf spring	100 Multijet 2,2 D, 110 Multijet 2,3 D, 115 Multijet 2,0 D, 120 Multijet 2,3 D, 130 Multijet 2,3 D, 140 Natural Power, 150 Multijet 2,3 D, 150 Multijet 3,0 D, 160 Multijet 3,0 D, 3,0 D Multijet		F8-7791		d=16,5; L=86,9; D=66,7

**DUCATO Box (250, 290)**

07/2006 →

Alternator Freewheel Clutch	120 Multijet 2,3 D, 130 Multijet 2,3 D		F5-1013		
Alternator Freewheel Clutch	115 Multijet 2,0 D		F5-1072		
Alternator Freewheel Clutch	115 Multijet 2,0 D		F5-1098		
Alternator Freewheel Clutch	100 Multijet 2,2 D		F5-1125		
Alternator Freewheel Clutch	140 Natural Power, 150 Multijet 3,0 D, 160 Multijet 3,0 D, 3,0 D Multijet		F5-1148		

<b>F5-1013</b>	<b>F5-1046</b>	<b>F5-1072</b>	<b>F5-1098</b>	<b>F5-1125</b>	<b>F5-1148</b>	<b>F8-6610</b>
Ref.Nr.: 038903119L	Ref.Nr.: 30667687	Ref.Nr.: 30667067	Ref.Nr.: 77364725	Ref.Nr.: 77364082	Ref.Nr.: 77364797	Ref.Nr.: 5038.A4
<b>F8-6611</b>	<b>F8-6612</b>	<b>F8-6613</b>	<b>F8-6614</b>	<b>F8-6712</b>	<b>F8-7080</b>	<b>F8-7081</b>
Ref.Nr.: 1350788080	Ref.Nr.: 1343631080	Ref.Nr.: 1344335080	Ref.Nr.: 1348993080	Ref.Nr.: 1352888080	Ref.Nr.: 500332292	Ref.Nr.: 0515.T4
<b>F8-7154</b>	<b>F8-7467</b>	<b>F8-7468</b>	<b>F8-7790</b>	<b>F8-7791</b>		
Ref.Nr.: 503530	Ref.Nr.: 5038E3	Ref.Nr.: 503447	Ref.Nr.: 5131.F6	Ref.Nr.: 5102.P8		

**Article Description****Article Nr.****Fitting Position****DUCATO Box (250, 290) 07/2006 →**

Top Strut Mounting	100 Multijet 2,2 D, 120 Multijet 2,3 D, 160 Multijet 3,0 D		<b>F8-6610</b>		
Top Strut Mounting	100 Multijet 2,2 D, 120 Multijet 2,3 D, 130 Multijet 2,3 D, 160 Multijet 3,0 D		<b>F8-6611</b>		
Engine Mounting	100 Multijet 2,2 D		<b>F8-6612</b>		
Engine Mounting	120 Multijet 2,3 D, 130 Multijet 2,3 D, 150 Multijet 2,3 D	not for transmission type: M38	<b>F8-6612</b>		
Engine Mounting	160 Multijet 3,0 D		<b>F8-6613</b>		
Engine Mounting	100 Multijet 2,2 D, 120 Multijet 2,3 D, 130 Multijet 2,3 D		<b>F8-6614</b>		
Mounting, manual transmission	100 Multijet 2,2 D, 120 Multijet 2,3 D, 130 Multijet 2,3 D, 150 Multijet 3,0 D, 160 Multijet 3,0 D		<b>F8-6712</b>		
Top Strut Mounting	100 Multijet 2,2 D, 120 Multijet 2,3 D, 160 Multijet 3,0 D		<b>F8-7467</b>		
Top Strut Mounting	100 Multijet 2,2 D, 120 Multijet 2,3 D, 160 Multijet 3,0 D		<b>F8-7468</b>		
Mounting, leaf spring	100 Multijet 2,2 D, 110 Multijet 2,3 D, 115 Multijet 2,0 D, 120 Multijet 2,3 D, 130 Multijet 2,3 D, 140 Natural Power, 150 Multijet 2,3 D, 150 Multijet 3,0 D, 160 Multijet 3,0 D, 3,0 D Multijet, Multijet		<b>F8-7790</b>		H=43; d=28; D=50
Mounting, leaf spring	100 Multijet 2,2 D, 110 Multijet 2,3 D, 115 Multijet 2,0 D, 120 Multijet 2,3 D, 130 Multijet 2,3 D, 140 Natural Power, 150 Multijet 2,3 D, 150 Multijet 3,0 D, 160 Multijet 3,0 D, 3,0 D Multijet, Multijet		<b>F8-7791</b>		d=16,5; L=86,9; D=66,7

**DUCATO Platform/Chassis (250, 290) 07/2006 →**

Alternator Freewheel Clutch	120 Multijet 2,3 D, 130 Multijet 2,3 D		<b>F5-1013</b>		
Alternator Freewheel Clutch	115 Multijet 2,0 D		<b>F5-1072</b>		
Alternator Freewheel Clutch	115 Multijet 2,0 D		<b>F5-1098</b>		
Alternator Freewheel Clutch	100 Multijet 2,2 D		<b>F5-1125</b>		
Alternator Freewheel Clutch	150 Multijet 3,0 D, 160 Multijet 3,0 D, 3,0 D Multijet		<b>F5-1148</b>		
Top Strut Mounting	100 Multijet 2,2 D, 120 Multijet 2,3 D, 160 Multijet 3,0 D		<b>F8-6610</b>		
Top Strut Mounting	100 Multijet 2,2 D, 120 Multijet 2,3 D, 160 Multijet 3,0 D		<b>F8-6611</b>		
Engine Mounting	100 Multijet 2,2 D		<b>F8-6612</b>		
Engine Mounting	120 Multijet 2,3 D, 130 Multijet 2,3 D, 150 Multijet 2,3 D	not for transmission type: M38	<b>F8-6612</b>		
Engine Mounting	160 Multijet 3,0 D		<b>F8-6613</b>		
Engine Mounting	100 Multijet 2,2 D, 120 Multijet 2,3 D, 130 Multijet 2,3 D		<b>F8-6614</b>		
Mounting, manual transmission	100 Multijet 2,2 D, 120 Multijet 2,3 D, 160 Multijet 3,0 D		<b>F8-6712</b>		
Top Strut Mounting	100 Multijet 2,2 D, 120 Multijet 2,3 D, 160 Multijet 3,0 D		<b>F8-7467</b>		
Top Strut Mounting	100 Multijet 2,2 D, 120 Multijet 2,3 D, 160 Multijet 3,0 D		<b>F8-7468</b>		
Mounting, leaf spring	100 Multijet 2,2 D, 110 Multijet 2,3 D, 115 Multijet 2,0 D, 120 Multijet 2,3 D, 130 Multijet 2,3 D, 140 Natural Power, 150 Multijet 2,3 D, 150 Multijet 3,0 D, 160 Multijet 3,0 D, 3,0 D Multijet		<b>F8-7790</b>		H=43; d=28; D=50

<b>F5-1013</b>	<b>F5-1072</b>	<b>F5-1098</b>	<b>F5-1125</b>	<b>F5-1148</b>	<b>F8-6610</b>	<b>F8-6611</b>
Ref.Nr.: 038903119L	Ref.Nr.: 30667067	Ref.Nr.: 77364725	Ref.Nr.: 77364082	Ref.Nr.: 77364797	Ref.Nr.: 5038.A4	Ref.Nr.: 1350788080
<b>F8-6612</b>	<b>F8-6613</b>	<b>F8-6614</b>	<b>F8-6712</b>	<b>F8-7467</b>	<b>F8-7468</b>	<b>F8-7790</b>
Ref.Nr.: 1343631080	Ref.Nr.: 1344335080	Ref.Nr.: 1348993080	Ref.Nr.: 1352888080	Ref.Nr.: 5038E3	Ref.Nr.: 503447	Ref.Nr.: 5131.F6
<b>F8-7791</b>						
Ref.Nr.: 5102.P8						

Article Description



Article Nr.

Fitting Position



<b>DUCATO Platform/Chassis (250, 290)</b>			<b>07/2006 →</b>		
Mounting, leaf spring	100 Multijet 2,2 D, 110 Multijet 2,3 D, 115 Multijet 2,0 D, 120 Multijet 2,3 D, 130 Multijet 2,3 D, 140 Natural Power, 150 Multijet 2,3 D, 150 Multijet 3,0 D, 160 Multijet 3,0 D, 3,0 D Multijet	F8-7791			d=16,5; L=86,9; D=66,7
<b>DUNA (146 B)</b>			<b>01/1987 → 12/1991</b>		
Anti-Friction Bearing	All Models	F8-3017			d=50; D=70
Top Strut Mounting	All Models	F8-5927			
Top Strut Mounting	All Models	F8-6342			
Engine Mounting	DS 1.7	F8-6894			
<b>DUNA Weekend (146 B)</b>			<b>01/1987 → 12/1991</b>		
Anti-Friction Bearing	All Models	F8-3017			d=50; D=70
Top Strut Mounting	All Models	F8-5927			
Top Strut Mounting	All Models	F8-6342			
<b>ELBA (146_)</b>			<b>04/1989 → 12/1996</b>		
Engine Mounting	1.7 D	F8-6894			
<b>FIORINO (127)</b>			<b>01/1980 → 12/1987</b>		
Control Arm-/Trailing Arm Bush	1050	G9-508			H1=34; H2=44; d=10; D=29
Stabiliser Mounting	1050	G9-512			H=25; d=14; D=41
<b>FIORINO Box (146)</b>			<b>01/1988 → 05/2001</b>		
Dust Cover Kit, shock absorber	60 1.1, 70 i.e. 1.4	AK-735005			
Anti-Friction Bearing	60 1.7 D	F8-3013			H=7; d=49; D=71
Anti-Friction Bearing	1.7 D, 60 1.1, 60 1.7 D, 65 1.7 TD, 70 1.3, 70 i.e. 1.4, 75 i.e. 1.5, 75 i.e. 1.6	F8-3017			d=50; D=70
Top Strut Mounting	60 1.1, 60 1.7 D, 70 1.3, 70 i.e. 1.4, 75 i.e. 1.5	F8-5515			
Top Strut Mounting	60 1.1, 60 1.7 D, 65 1.7 TD, 70 1.3, 70 i.e. 1.4, 75 i.e. 1.5, 75 i.e. 1.6	F8-6342			
Bush, leaf spring	All Models	F8-6602			H=77; d=14; D=34.4
Stabiliser Mounting	1.0 iE, 1.4, 1.7 D, 60 1.1, 60 1.7 D, 65 1.7 TD, 70 1.3, 70 i.e. 1.4, 75 i.e. 1.5, 75 i.e. 1.6	F8-6791			D=22
Engine Mounting	60 1.7 D, 65 1.7 TD	F8-6894			
<b>FIORINO Pick up (146)</b>			<b>01/1988 → 05/2001</b>		
Anti-Friction Bearing	1.3, 1.4, 1.6, 1.7 D, 1.7 TD	F8-3017			d=50; D=70
Top Strut Mounting	1.3, 1.4, 1.6, 1.7 D, 1.7 TD	F8-6342			
Bush, leaf spring	1.3, 1.4, 1.6, 1.7 D, 1.7 TD	F8-6602			H=77; d=14; D=34.4
Stabiliser Mounting	1.7 D, 1.7 TD	F8-6791			D=22
Engine Mounting	1.7 D, 1.7 TD	F8-6894			



**Article Description****Article Nr.****Fitting Position**

<b>FIORINO (147)</b>			<b>01/1980 → 10/1993</b>		
Anti-Friction Bearing	1.0, 1.1 60, 1.3 Diesel, 1.5, 1.7 Diesel		<b>F8-3017</b>		d=50; D=70
Anti-Friction Bearing	1.3, 1.7 Diesel	01/1988 →	<b>F8-3017</b>		d=50; D=70
Top Strut Mounting	1.3, 1.5, 1.7 Diesel	07/1988 →;	<b>F8-6342</b>		
Stabiliser Mounting	1.5, 1.7 Diesel		<b>F8-6791</b>		D=22
Control Arm-/Trailing Arm Bush	1.3, 1.7 Diesel		<b>G9-508</b>		H1=34; H2=44; d=10; D=29
Stabiliser Mounting	1.3, 1.7 Diesel	01/1988 →	<b>G9-512</b>		H=25; d=14; D=41
Stabiliser Mounting	1.7 Diesel		<b>G9-512</b>		H=25; d=14; D=41
<b>FIORINO Pick up (147)</b>			<b>05/1984 → 12/1988</b>		
Anti-Friction Bearing	1.3 D		<b>F8-3017</b>		d=50; D=70
<b>FIORINO Box Body / Estate (225)</b>			<b>11/2007 →</b>		
Alternator Freewheel Clutch	1.3 D Multijet		<b>F5-1041</b>		
Alternator Freewheel Clutch	1.3 D Multijet		<b>F5-1045</b>		
Belt Pulley, crankshaft	1.4	KfV; Number of Ribs: 5; Parameter: 6PK	<b>F8-6394</b>		H=25; d=44.05; Mounting points diam.[mm]=9; D=148; D1=142.9
Engine Mounting	1.3 D Multijet, 1.4		<b>F8-6615</b>		
Engine Mounting	1.3 D Multijet	Ver.: Cambio robotizzato, Selespeed	<b>F8-6624</b>		
Engine Mounting	1.3 D Multijet		<b>F8-6630</b>		
Engine Mounting	1.3 D Multijet	SELESPEED; not for exhaust-emission standard: Euro 5; Automated	<b>F8-6713</b>		
Top Strut Mounting	1.3 D Multijet, 1.4, 1.4 Natural Power		<b>F8-7428</b>		
Top Strut Mounting	1.3 D Multijet, 1.4, 1.4 Natural Power		<b>F8-7429</b>		
Belt Pulley, crankshaft	1.3 D Multijet	Number of grooves: 4, 6; Number of Ribs: 3, 5; Parameter: 4PK+6PK	<b>F8-7647</b>		d=35.03; Mounting points diam.[mm]=8.5; D1=164.9; D2=145
Protective Cap/Bellow, shock absorber	1.3 D Multijet, 1.4, 1.4 Natural Power		<b>F8-7663</b>		H=205
Control Arm-/Trailing Arm Bush	1.3 D Multijet, 1.4, 1.4 Natural Power		<b>F8-7995</b>		
<b>PUNTO Van (199)</b>			<b>04/2008 →</b>		
Alternator Freewheel Clutch	1.3 D Multijet		<b>F5-1041</b>		
Alternator Freewheel Clutch	1.3 D Multijet		<b>F5-1045</b>		
Control Arm-/Trailing Arm Bush	1.3 D Multijet		<b>F8-7995</b>		
<b>IDEA (350_)</b>			<b>12/2003 → 07/2010</b>		
Dust Cover Kit, shock absorber	1.2 16V, 1.3 D Multijet, 1.3 JTD, 1.4, 1.4 16V, 1.9 JTD		<b>AK-735345</b>		
Dust Cover Kit, shock absorber	1.2 16V, 1.3 D Multijet, 1.3 JTD, 1.4, 1.4 16V, 1.9 JTD		<b>AK-735346</b>		
Alternator Freewheel Clutch	1.3 D Multijet, 1.3 JTD		<b>F5-1041</b>		

<b>AK-735345</b>	<b>AK-735346</b>	<b>F5-1041</b>	<b>F5-1045</b>	<b>F8-3017</b>	<b>F8-6342</b>	<b>F8-6394</b>
Ref.Nr.: 50701077	Ref.Nr.: 51796607	Ref.Nr.: 77364723	Ref.Nr.: 77362721	Ref.Nr.: 4400895	Ref.Nr.: 7583185	Ref.Nr.: 0515.R8
<b>F8-6615</b>	<b>F8-6624</b>	<b>F8-6630</b>	<b>F8-6713</b>	<b>F8-6791</b>	<b>F8-7428</b>	<b>F8-7429</b>
Ref.Nr.: 51761609	Ref.Nr.: 51782560	Ref.Nr.: 51799110	Ref.Nr.: 51805433	Ref.Nr.: 7692557	Ref.Nr.: 5038J8	Ref.Nr.: 5038G8
<b>F8-7647</b>	<b>F8-7663</b>	<b>F8-7995</b>	<b>G9-508</b>	<b>G9-512</b>		
Ref.Nr.: 55182506	Ref.Nr.: 344435	Ref.Nr.: 55700751	Ref.Nr.: 07674701	Ref.Nr.: 07544738		

Article Description



Article Nr.

Fitting Position



## IDEA (350\_)

12/2003 → 07/2010

Alternator Freewheel Clutch	1.3 D Multijet, 1.3 JTD		<b>F5-1045</b>		
Alternator Freewheel Clutch	1.6 D Multijet, 1.8, 1.9 JTD		<b>F5-1098</b>		
Alternator Freewheel Clutch	1.8, 1.9 JTD		<b>F5-1123</b>		
Anti-Friction Bearing	1.3 JTD, 1.9 JTD		<b>F8-6266</b>		
Top Strut Mounting	1.3 JTD, 1.9 JTD	<b>ST</b>	<b>F8-6288</b>		
Belt Pulley, crankshaft	1.9 JTD	Number of Ribs: 5; Parameter: 6PK; with screw set	<b>F8-6393</b>		D=169
Control Arm-/Trailing Arm Bush	1.2 16V, 1.3 D Multijet, 1.3 JTD, 1.4, 1.4 16V, 1.4 LPG, 1.6 D Multijet, 1.9 JTD		<b>F8-6442</b>		
Control Arm-/Trailing Arm Bush	1.2 16V, 1.3 D Multijet, 1.3 JTD, 1.4, 1.4 16V, 1.9 JTD		<b>F8-6450</b>	⊕ ⊕	
Spring Cap	1.2 16V, 1.3 JTD, 1.4 16V, 1.9 JTD		<b>F8-6560</b>		
Spring Cap	1.2 16V, 1.3 D Multijet, 1.3 JTD, 1.4, 1.4 16V, 1.9 JTD		<b>F8-6561</b>	↓	
Belt Pulley, crankshaft	1.3 D Multijet, 1.3 JTD	Number of Ribs: 6	<b>F8-7086</b>		Belt Pulley Ø [mm]=165; Mounting points diam.[mm]=35; W=30
Rubber Buffer, suspension	1.2 16V, 1.3 D Multijet, 1.3 JTD, 1.4, 1.4 16V, 1.6 D Multijet, 1.9 JTD		<b>F8-7594</b>	⊕ ⊕	H=228
Mounting, manual transmission	1.2 16V, 1.4, 1.4 16V		<b>F8-8086</b>		

## LINEA (323)

06/2007 →

Alternator Freewheel Clutch	1.3 D Multijet		<b>F5-1041</b>		
Alternator Freewheel Clutch	1.3 D Multijet		<b>F5-1045</b>		
Alternator Freewheel Clutch	1.6 D Multijet		<b>F5-1098</b>		
Engine Mounting	1.4 T-Jet		<b>F8-6615</b>	⊕ ↑	
Engine Mounting	1.3 D Multijet	Ver.: Cambio robotizzato, Selespeed	<b>F8-6624</b>		
Engine Mounting	1.4		<b>F8-6625</b>		
Engine Mounting	1.4		<b>F8-6626</b>		
Holder, engine mounting	1.4		<b>F8-6627</b>		
Engine Mounting	1.3 D Multijet		<b>F8-6628</b>		
Engine Mounting	1.4 T-Jet		<b>F8-6629</b>		
Engine Mounting	1.3 D Multijet		<b>F8-6630</b>		
Engine Mounting	1.3 D Multijet	SELESPEED; Automated	<b>F8-6713</b>		
Top Strut Mounting	1.3 D Multijet, 1.4, 1.4 T-Jet, 1.6 D Multijet		<b>F8-7428</b>	⊕	
Top Strut Mounting	1.3 D Multijet, 1.4, 1.4 T-Jet, 1.6 D Multijet		<b>F8-7429</b>	⊕	
Belt Pulley, crankshaft	1.3 D Multijet	Number of grooves: 4, 6; Number of Ribs: 3, 5; Parameter: 4PK+6PK	<b>F8-7647</b>		d=35.03; Mounting points diam.[mm]=8.5; D1=164.9; D2=145
Protective Cap/Bellow, shock absorber	1.3 D Multijet, 1.4, 1.4 T-Jet, 1.6 D Multijet		<b>F8-7663</b>	⊕ ⊕	H=205

<b>F5-1041</b>	<b>F5-1045</b>	<b>F5-1098</b>	<b>F5-1123</b>	<b>F8-6266</b>	<b>F8-6288</b>	<b>F8-6393</b>
Ref.Nr.: 77364723	Ref.Nr.: 77362721	Ref.Nr.: 77364725	Ref.Nr.: 9948513	Ref.Nr.: 5035C2	Ref.Nr.: 50702206	Ref.Nr.: 55196301
<b>F8-6442</b>	<b>F8-6450</b>	<b>F8-6560</b>	<b>F8-6561</b>	<b>F8-6615</b>	<b>F8-6624</b>	<b>F8-6625</b>
Ref.Nr.: 50703231-PART	Ref.Nr.: 46551790	Ref.Nr.: 46541086	Ref.Nr.: 46750910	Ref.Nr.: 51761609	Ref.Nr.: 51782560	Ref.Nr.: 51813605
<b>F8-6626</b>	<b>F8-6627</b>	<b>F8-6628</b>	<b>F8-6629</b>	<b>F8-6630</b>	<b>F8-6713</b>	<b>F8-7086</b>
Ref.Nr.: 51813606	Ref.Nr.: 51813607	Ref.Nr.: 51813603	Ref.Nr.: 51813029	Ref.Nr.: 51799110	Ref.Nr.: 51805433	Ref.Nr.: 55200498



**Article Description****Article Nr.****Fitting Position**

<b>LINEA (323)</b>		<b>06/2007 →</b>	
Control Arm-/Trailing Arm Bush	1.3 D Multijet, 1.4, 1.4 T-Jet, 1.6, 1.6 D Multijet, 1.9 16V	<b>F8-7995</b>	
<b>MAREA (185)</b>		<b>09/1996 → 08/2002</b>	
Dust Cover Kit, shock absorber	1.4 80 12V, 1.6 100 16V, 1.6 100 16V Bipower, 1.8 115 16V, 1.9 JTD 105, 1.9 JTD 110, 1.9 TD 100, 1.9 TD 75, 2.0 150 20V, 2.0 155 20V, 2.4 JTD 130	<b>AK-735110</b>	
Dust Cover Kit, shock absorber	1.2 16V, 1.4 80 12V, 1.6, 1.6 100 16V, 1.6 100 16V Bipower, 1.6 SX, 1.8 115 16V, 1.9 JTD 105, 1.9 JTD 110, 1.9 TD 100, 1.9 TD 75, 2.0 150 20V, 2.0 155 20V, 2.4 JTD 130, 2.4 TD 125	<b>AK-735347</b>	
Alternator Freewheel Clutch	1.9 JTD 105, 1.9 TD 100, 2.4 JTD 130	<b>F5-1005</b>	
Alternator Freewheel Clutch	2.4 JTD 130	<b>F5-1108</b>	
Alternator Freewheel Clutch	1.9 JTD 110, 1.9 TD 100, 2.4 JTD 130	<b>F5-1123</b>	
Top Strut Mounting	1.2 16V, 1.4 80 12V, 1.6, 1.6 100 16V, 1.6 100 16V Bipower, 1.6 16V, 1.6 SX, 1.8 115 16V, 1.9 JTD 105, 1.9 JTD 110, 1.9 TD 100, 1.9 TD 75, 2.0 150 20V, 2.0 155 20V, 2.4 JTD 130, 2.4 TD 125	<b>F8-5600</b>	
Belt Pulley, crankshaft	1.9 JTD 105, 1.9 JTD 110, 1.9 TD 75	Number of Ribs: 5; Parameter: 6PK; with screw set	<b>F8-6393</b>
Engine Mounting	1.8 115 16V, 2.0 150 20V, 2.0 155 20V		<b>F8-6631</b>
Engine Mounting	1.6, 1.6 100 16V, 1.6 100 16V Bipower, 1.6 SX, 2.0 150 20V, 2.0 155 20V		<b>F8-6632</b>
Engine Mounting	1.6 100 16V		<b>F8-6936</b>
Engine Mounting	1.6 100 16V Bipower	185 A3.000;	<b>F8-6936</b>
Engine Mounting	1.4 80 12V		<b>F8-6939</b>
Engine Mounting	1.4 80 12V		<b>F8-6940</b>
Engine Mounting	1.4 80 12V		<b>F8-6941</b>
Belt Pulley, crankshaft	2.4 JTD 130, 2.4 TD 125	Number of Ribs: 6	<b>F8-7087</b>
Control Arm-/Trailing Arm Bush	1.2 16V, 1.4 80 12V, 1.6 100 16V, 1.6 100 16V Bipower, 1.8 115 16V, 1.9 JTD 105, 1.9 TD 100, 1.9 TD 75, 2.0 150 20V, 2.0 155 20V, 2.4 JTD 130, 2.4 TD 125		<b>G9-530</b>
Bellow, steering	1.8 115 16V, 1.9 JTD 105, 1.9 JTD 110, 1.9 TD 100, 1.9 TD 75, 2.0 150 20V, 2.0 155 20V, 2.4 JTD 130, 2.4 TD 125	with clamps	<b>LM-10008S</b>
Bellow, steering	1.8 115 16V, 1.9 JTD 105, 1.9 JTD 110, 1.9 TD 100, 1.9 TD 75, 2.0 150 20V, 2.0 155 20V, 2.4 JTD 130, 2.4 TD 125	with clamps	<b>LM-10025S</b>

<b>AK-735110</b>	<b>AK-735347</b>	<b>F5-1005</b>	<b>F5-1108</b>	<b>F5-1123</b>	<b>F8-5600</b>	<b>F8-6393</b>
Ref.Nr.: 55700751	Ref.Nr.: 46470781	Ref.Nr.: 9951162	Ref.Nr.: 46441617	Ref.Nr.: 9948513	Ref.Nr.: 46445246	Ref.Nr.: 55196301
<b>F8-6631</b>	<b>F8-6632</b>	<b>F8-6936</b>	<b>F8-6939</b>	<b>F8-6940</b>	<b>F8-6941</b>	<b>F8-7087</b>
Ref.Nr.: 077 824 35	Ref.Nr.: 60813084	Ref.Nr.: 7778563	Ref.Nr.: 7764084	Ref.Nr.: 7765921	Ref.Nr.: 7764414	Ref.Nr.: 55184474
<b>F8-7995</b>	<b>G9-530</b>	<b>LM-10008S</b>	<b>LM-10025S</b>			
Ref.Nr.: 55700751	Ref.Nr.: 7601064	Ref.Nr.: 9947369	Ref.Nr.: 9947369			

Article Description



Article Nr.

Fitting Position



<b>MAREA Weekend (185)</b>		<b>09/1996 → 02/2003</b>	
Dust Cover Kit, shock absorber	1.4 80 12V, 1.6 100 16V, 1.8 115 16V, 1.9 JTD 105, 1.9 JTD 110, 1.9 TD 100, 1.9 TD 75, 2.0 150 20V, 2.0 155 20V, 2.4 JTD 130		AK-735110
Dust Cover Kit, shock absorber	1.2 16V, 1.4 80 12V, 1.6 100 16V, 1.8 115 16V, 1.9 JTD 105, 1.9 JTD 110, 1.9 TD 100, 1.9 TD 75, 2.0 150 20V, 2.0 155 20V, 2.4 JTD 130, 2.4 TD 125		AK-735347
Alternator Freewheel Clutch	1.9 JTD 105, 1.9 TD 100, 2.4 JTD 130		F5-1005
Alternator Freewheel Clutch	2.4 JTD 130		F5-1108
Alternator Freewheel Clutch	1.9 JTD 110, 1.9 TD 100, 2.4 JTD 130		F5-1123
Top Strut Mounting	1.2 16V, 1.4 80 12V, 1.6, 1.6 100 16V, 1.8 115 16V, 1.9 JTD 105, 1.9 JTD 110, 1.9 TD 100, 1.9 TD 75, 2.0 150 20V, 2.0 155 20V, 2.4 JTD 130, 2.4 TD 125		F8-5600
Belt Pulley, crankshaft	1.9 JTD 105, 1.9 JTD 110, 1.9 TD 75	Number of Ribs: 5; Parameter: 6PK; with screw set	F8-6393
Engine Mounting	1.8 115 16V, 2.0 150 20V, 2.0 155 20V		F8-6631
Engine Mounting	1.6, 1.6 100 16V, 2.0 150 20V, 2.0 155 20V		F8-6632
Engine Mounting	1.6 100 16V		F8-6936
Engine Mounting	1.4 80 12V		F8-6939
Engine Mounting	1.4 80 12V		F8-6940
Engine Mounting	1.4 80 12V		F8-6941
Belt Pulley, crankshaft	2.4 JTD 130, 2.4 TD 125	Number of Ribs: 6	F8-7087
Control Arm-/Trailing Arm Bush	1.2 16V, 1.4 80 12V, 1.6 100 16V, 1.8 115 16V, 1.9 JTD 105, 1.9 TD 100, 1.9 TD 75, 2.0 150 20V, 2.0 155 20V, 2.4 JTD 130, 2.4 TD 125		G9-530
Bellow, steering	1.8 115 16V, 1.9 JTD 105, 1.9 JTD 110, 1.9 TD 100, 1.9 TD 75, 2.0 150 20V, 2.0 155 20V, 2.4 JTD 130, 2.4 TD 125	with clamps	LM-10008S
Bellow, steering	1.8 115 16V, 1.9 JTD 105, 1.9 JTD 110, 1.9 TD 100, 1.9 TD 75, 2.0 150 20V, 2.0 155 20V, 2.4 JTD 130, 2.4 TD 125	with clamps	LM-10025S
<b>MULTIPLA (186)</b>		<b>04/1999 → 06/2010</b>	
Dust Cover Kit, shock absorber	1.6, 1.6 100 16V, 1.6 16V, 1.6 16V Bipower, 1.6 16V Blupower, 1.9 JTD, 1.9 JTD 105, 1.9 JTD 110, 1.9 JTD 115		AK-735348
Dust Cover Kit, shock absorber	1.6, 1.6 100 16V, 1.6 16V, 1.6 16V Bipower, 1.6 16V Blupower, 1.9 JTD, 1.9 JTD 105, 1.9 JTD 110, 1.9 JTD 115		AK-735349
Alternator Freewheel Clutch	1.9 JTD 105, 1.9 JTD 115		F5-1005
Alternator Freewheel Clutch	1.9 JTD, 1.9 JTD 105, 1.9 JTD 110, 1.9 JTD 115		F5-1123

<b>AK-735110</b>	<b>AK-735347</b>	<b>AK-735348</b>	<b>AK-735349</b>	<b>F5-1005</b>	<b>F5-1108</b>	<b>F5-1123</b>
Ref.Nr.:	Ref.Nr.: 46470781	Ref.Nr.: 46550122	Ref.Nr.: 46550123	Ref.Nr.: 9951162	Ref.Nr.: 46441617	Ref.Nr.: 9948513
<b>F8-3014</b>	<b>F8-5600</b>	<b>F8-6393</b>	<b>F8-6631</b>	<b>F8-6632</b>	<b>F8-6936</b>	<b>F8-6939</b>
Ref.Nr.: 503545	Ref.Nr.: 46445246	Ref.Nr.: 55196301	Ref.Nr.: 077 824 35	Ref.Nr.: 60813084	Ref.Nr.: 7778563	Ref.Nr.: 7764084
<b>F8-6940</b>	<b>F8-6941</b>	<b>F8-7087</b>	<b>G9-530</b>	<b>LM-10008S</b>	<b>LM-10025S</b>	
Ref.Nr.: 7765921	Ref.Nr.: 7764414	Ref.Nr.: 55184474	Ref.Nr.: 7601064	Ref.Nr.: 9947369	Ref.Nr.: 9947369	

**Article Description****Article Nr.****Fitting Position**

<b>MULTIPLA (186)</b>		<b>04/1999 → 06/2010</b>	
Anti-Friction Bearing	1.6, 1.6 100 16V, 1.6 16V, 1.6 16V Bipower, 1.6 16V Blupower, 1.9 JTD, 1.9 JTD 105, 1.9 JTD 110, 1.9 JTD 115	<b>F8-3014</b>	H1=24; H2=46; d1=78; d2=84; D=128
Spring Cap	1.6, 1.6 100 16V, 1.6 16V Bipower, 1.6 16V Blupower, 1.9 JTD 105, 1.9 JTD 110, 1.9 JTD 115	<b>F8-5956</b>	
Top Strut Mounting	1.6, 1.6 100 16V, 1.6 16V, 1.6 16V Bipower, 1.6 16V Blupower, 1.9 JTD, 1.9 JTD 105, 1.9 JTD 110, 1.9 JTD 115	<b>F8-6291</b>	
Belt Pulley, crankshaft	1.9 JTD 105, 1.9 JTD 110, 1.9 JTD 115	<b>F8-6393</b>	Number of Ribs: 5; Parameter: 6PK; with screw set D=169
<b>PALIO (178BX)</b>		<b>04/1996 → 10/2003</b>	
Dust Cover Kit, shock absorber	1.2, 1.3 JTD Multijet, 1.6, 1.6 16V, 1.7 TD, 1.9 D	<b>AK-735443</b>	
Alternator Freewheel Clutch	1.9 D	<b>F5-1005</b>	
Alternator Freewheel Clutch	1.3, 1.3 JTD Multijet	<b>F5-1045</b>	
Alternator Freewheel Clutch	1.9 D	<b>F5-1123</b>	
Control Arm-/Trailing Arm Bush	1.0, 1.2, 1.4, 1.4 CAT, 1.5, 1.6 16V	<b>F8-5273</b>	
Top Strut Mounting	1.0, 1.2, 1.4, 1.4 CAT, 1.5, 1.6 16V	<b>F8-6367</b>	
Control Arm-/Trailing Arm Bush	1.0, 1.2, 1.4, 1.4 CAT, 1.5, 1.6 16V	<b>F8-6633</b>	
Top Strut Mounting	1.0, 1.2, 1.4, 1.4 CAT, 1.5, 1.6 16V	<b>F8-7158</b>	
Belt Pulley, crankshaft	1.3 JTD Multijet	<b>F8-7647</b>	Number of grooves: 4, 6; Number of Ribs: 3, 5; Parameter: 4PK+6PK d=35.03; Mounting points diam.[mm]=8.5; D1=164.9; D2=145
Repair Set, axle beam	1.0, 1.1, 1.2, 1.4, 1.4 CAT, 1.5, 1.6, 1.6 16V, 1.7 TD, 1.9 D	<b>G8-555</b>	
<b>PALIO Weekend (178DX)</b>		<b>04/1996 → 10/2003</b>	
Dust Cover Kit, shock absorber	1.6, 1.6 16V, 1.7 TD, 1.9 D, 1.9 JTD	<b>AK-735347</b>	
Dust Cover Kit, shock absorber	1.2, 1.4, 1.6 16V, 1.7 TD, 1.9 D, 1.9 JTD	<b>AK-735443</b>	
Alternator Freewheel Clutch	1.9 D, 1.9 JTD	<b>F5-1005</b>	
Alternator Freewheel Clutch	1.9 D, 1.9 JTD	<b>F5-1123</b>	
Control Arm-/Trailing Arm Bush	1.2, 1.6 16V, 1.7 TD	<b>F8-5273</b>	for OE: 46554597 
Control Arm-/Trailing Arm Bush	1.2, 1.6 16V, 1.9 D	<b>F8-5273</b>	
Control Arm-/Trailing Arm Bush	1.2, 1.6 16V, 1.7 TD, 1.9 D	<b>F8-5274</b>	
Control Arm-/Trailing Arm Bush	1.2, 1.6 16V, 1.7 TD, 1.9 D	<b>F8-5275</b>	
Control Arm-/Trailing Arm Bush	1.2, 1.6 16V, 1.7 TD, 1.9 D	<b>F8-5276</b>	

<b>AK-735347</b>	<b>AK-735443</b>	<b>F5-1005</b>	<b>F5-1045</b>	<b>F5-1123</b>	<b>F8-3014</b>	<b>F8-5273</b>
Ref.Nr.: 46470781	Ref.Nr.: 46464298	Ref.Nr.: 9951162	Ref.Nr.: 77362721	Ref.Nr.: 9948513	Ref.Nr.: 503545	Ref.Nr.: 46421522
<b>F8-5274</b>	<b>F8-5275</b>	<b>F8-5276</b>	<b>F8-5277</b>	<b>F8-5956</b>	<b>F8-6291</b>	<b>F8-6367</b>
Ref.Nr.: 46454061	Ref.Nr.: 46454062	Ref.Nr.: 46551376	Ref.Nr.: 46551377	Ref.Nr.: 7602150	Ref.Nr.: 1303672080	Ref.Nr.: 46760673
<b>F8-6393</b>	<b>F8-6633</b>	<b>F8-7158</b>	<b>F8-7647</b>	<b>G8-555</b>		
Ref.Nr.: 55196301	Ref.Nr.: 46450461	Ref.Nr.: 46760674	Ref.Nr.: 55182506	Ref.Nr.:		

Article Description



Article Nr.

Fitting Position



### PALIO Weekend (178DX)

04/1996 → 10/2003

Control Arm-/Trailing Arm Bush	1.2, 1.6 16V, 1.7 TD, 1.9 D		F8-5277		
Top Strut Mounting	1.2, 1.6 16V, 1.7 TD, 1.9 D		F8-6367		
Belt Pulley, crankshaft	1.9 D	Number of Ribs: 5; Parameter: 6PK; with screw set	F8-6393		D=169
Control Arm-/Trailing Arm Bush	1.2, 1.6 16V, 1.7 TD, 1.9 D		F8-6633		
Top Strut Mounting	1.2, 1.6 16V, 1.7 TD, 1.9 D		F8-7158		
Top Strut Mounting	1.2, 1.4, 1.6 16V, 1.7 TD, 1.9 JTD		F8-7430		
Belt Pulley, crankshaft	1.2		F8-7648		
Repair Set, axle beam	1.2, 1.4, 1.6, 1.6 16V, 1.7 TD, 1.9 D, 1.9 JTD		G8-555		

### PANDA (141A\_)

10/1980 → 07/2004

Anti-Friction Bearing	1000, 1000 4x4, 1000 i.e. CAT, 1100, 1100 4x4, 1100 Trekking 4x4, 1300 D, 650, 750, 800, 900, 950		F8-3017		d=50; D=70
Anti-Friction Bearing	1100	03/1992 →	F8-3017		d=50; D=70
Anti-Friction Bearing	900	09/1982 →	F8-3017		d=50; D=70
Top Strut Mounting	All Models		F8-5957		
Top Strut Mounting	1000, 1000 4x4, 1000 i.e. CAT, 1100, 1100 4x4, 1100 Trekking 4x4, 1300 D, 650, 750, 800, 900, 950, 950 4x4		F8-5958		
Engine Mounting	1000 i.e. CAT, 750	01/1991 →;	F8-6887		
Engine Mounting	1000, 1100, 750		F8-6887		
Engine Mounting	1000 4x4	156 A2.100	F8-6893		
Engine Mounting	1000 4x4, 1000 i.e. CAT	156 A2.246	F8-6893		
Engine Mounting	1000, 1000 4x4, 1100, 1100 4x4, 1100 Trekking 4x4, 750		F8-6893		
Engine Mounting	1000 i.e. CAT	156 A2.246	F8-6911		
Engine Mounting	1000, 1000 4x4, 1100, 750, 900		F8-6911		
Engine Mounting	1000, 1000 4x4, 1100, 750, 900		F8-6911		
Engine Mounting	1000 4x4	156 A2.100	F8-6955		
Engine Mounting	1000 4x4	156 A2.246	F8-6955		
Engine Mounting	1000 4x4, 1100 4x4, 1100 Trekking 4x4		F8-6955		
Control Arm-/Trailing Arm Bush	1000, 1000 4x4, 1000 i.e. CAT, 1100, 1100 4x4, 1100 Trekking 4x4, 1300 D, 650, 750, 800, 900, 950 4x4		G9-506		H=37; d=9.2; D1=25; D2=36

### PANDA Van (141\_)

01/1986 → 02/2004

Anti-Friction Bearing	1000		F8-3017		d=50; D=70
Top Strut Mounting	1000, 1000 i.e. 750		F8-5957		
Top Strut Mounting	1.1, 1000, 1000 i.e. 750		F8-5958		

<b>F8-3017</b>	<b>F8-5277</b>	<b>F8-5957</b>	<b>F8-5958</b>	<b>F8-6367</b>	<b>F8-6393</b>	<b>F8-6633</b>
Ref.Nr.: 4400895	Ref.Nr.: 46551377	Ref.Nr.: SE141156228A	Ref.Nr.: 7635775	Ref.Nr.: 46760673	Ref.Nr.: 55196301	Ref.Nr.: 46450461
<b>F8-6887</b>	<b>F8-6893</b>	<b>F8-6911</b>	<b>F8-6955</b>	<b>F8-7158</b>	<b>F8-7430</b>	<b>F8-7648</b>
Ref.Nr.: 7667850	Ref.Nr.: 7613889	Ref.Nr.: 7544643	Ref.Nr.: 7550361	Ref.Nr.: 46760674	Ref.Nr.: 46464273	Ref.Nr.: 7778028
<b>G8-555</b>	<b>G9-506</b>					
Ref.Nr.:	Ref.Nr.: 0004288726					

**Article Description****Article Nr.****Fitting Position**

<b>PANDA Van (141_)</b>				<b>01/1986 → 02/2004</b>	
Engine Mounting	1000, 1000 i.e		<b>F8-6887</b>	⊕	
Engine Mounting	1000	156 A2.100	<b>F8-6893</b>		
Engine Mounting	1000 i.e		<b>F8-6893</b>		
Engine Mounting	1000 i.e		<b>F8-6911</b>	⊕	
Control Arm-/Trailing Arm Bush	1000, 1000 i.e, 750		<b>G9-506</b>	⊕ ⊕	H=37; d=9,2; D1=25; D2=36
<b>PANDA (169)</b>				<b>09/2003 → 11/2009</b>	
Alternator Freewheel Clutch	1.3 D Multijet, 1.3 D Multijet 4x4		<b>F5-1045</b>		
Control Arm-/Trailing Arm Bush	1.1, 1.2, 1.2 4x4, 1.3 D Multijet, 1.3 D Multijet 4x4		<b>F8-6246</b>	⊕ ⊕	H=52,5; d=12; D=33,5
Control Arm-/Trailing Arm Bush	1.1, 1.2, 1.2 4x4, 1.3 D Multijet, 1.3 D Multijet 4x4		<b>F8-6247</b>	⊕ ⊕	H=52; H1=26,5; d=14,5; D=60,5
Top Strut Mounting	1.1, 1.2, 1.2 4x4, 1.3 D Multijet, 1.3 D Multijet 4x4		<b>F8-6286</b>		
Spring Cap	1.1, 1.2, 1.2 4x4, 1.3 D Multijet, 1.3 D Multijet 4x4		<b>F8-6560</b>		
Spring Cap	1.1, 1.2, 1.2 4x4, 1.3 D Multijet, 1.3 D Multijet 4x4, 1.4		<b>F8-6561</b>	↓	
Belt Pulley, crankshaft	1.3 D Multijet	Number of Ribs: 6	<b>F8-7086</b>		Belt Pulley Ø [mm]=165; Mounting points diam.[mm]=35; W=30
Rubber Buffer, suspension	1.1, 1.2, 1.2 Bi-Power / Natural Power, 1.2 LPG, 1.3 D Multijet, 1.4		<b>F8-7484</b>	⊕ ⊕	
Rubber Buffer, suspension	All Models		<b>F8-7594</b>	⊕ ⊕	H=228
Rubber Buffer, suspension	1.1, 1.2, 1.2 4x4, 1.3 D Multijet, 1.3 D Multijet 4x4, 1.4		<b>F8-7597</b>	⊕ ⊕	H=244
<b>PANDA Van (169)</b>				<b>03/2004 →</b>	
Alternator Freewheel Clutch	1.3 JTD, 1.3 Multijet 4x4		<b>F5-1045</b>		
Rubber Buffer, suspension	1.1, 1.2, 1.3 JTD, 1.4 Natural Power		<b>F8-7484</b>	⊕ ⊕	
Rubber Buffer, suspension	1.1, 1.2, 1.2 4x4, 1.2 LPG, 1.3 JTD, 1.3 Multijet 4x4, 1.4 Natural Power		<b>F8-7594</b>	⊕ ⊕	H=228
<b>PANDA (312, 312_)</b>				<b>02/2012 →</b>	
Alternator Freewheel Clutch	1.3 D Multijet, 1.3 D Multijet 4x4		<b>F5-1045</b>		
<b>PUNTO (176)</b>				<b>09/1993 → 09/1999</b>	
Anti-Friction Bearing	1.4 GT Turbo, 1.7 D, 1.7 TD, 60 1.2, 60 TD 1.7, 75 1.2, 85 16V 1.2		<b>F8-3013</b>		H=7; d=49; D=71
Anti-Friction Bearing	55 1.1	01/1994 →	<b>F8-3013</b>		H=7; d=49; D=71
Engine Mounting	1.7 D, 1.7 TD, 60 TD 1.7		<b>F8-5414</b>		
Engine Mounting	55 1.1, 60 1.2, 75 1.2, 85 16V 1.2, 90 1.6		<b>F8-5415</b>		
Top Strut Mounting	All Models		<b>F8-5858</b>	⊕ ⊕	
Mounting, axle beam	All Models		<b>F8-5864</b>	⊕ ⊕	H=29; d=16; D=72

<b>F5-1045</b>	<b>F8-3013</b>	<b>F8-5414</b>	<b>F8-5415</b>	<b>F8-5858</b>	<b>F8-5864</b>	<b>F8-5937</b>
Ref.Nr.: 77362721	Ref.Nr.: 503517	Ref.Nr.: 46431619	Ref.Nr.: 7784313	Ref.Nr.: 07775940	Ref.Nr.: 46476755	Ref.Nr.: 07762158
<b>F8-6246</b>	<b>F8-6247</b>	<b>F8-6286</b>	<b>F8-6560</b>	<b>F8-6561</b>	<b>F8-6887</b>	<b>F8-6893</b>
Ref.Nr.: 50703128-PART	Ref.Nr.: 50703128	Ref.Nr.: 46746544	Ref.Nr.: 46541086	Ref.Nr.: 46750910	Ref.Nr.: 7667850	Ref.Nr.: 7613889
<b>F8-6911</b>	<b>F8-7086</b>	<b>F8-7484</b>	<b>F8-7594</b>	<b>F8-7597</b>	<b>G9-506</b>	
Ref.Nr.: 7544643	Ref.Nr.: 55200498	Ref.Nr.: 51811829	Ref.Nr.: 1 639 562	Ref.Nr.: 50703131	Ref.Nr.: 0004288726	

Article Description



Article Nr.

Fitting Position



<b>PUNTO (176)</b>			<b>09/1993 → 09/1999</b>		
Rubber Buffer, suspension	1.4 GT Turbo, 1.7 D, 1.7 TD, 55 1.1, 60 1.2, 75 1.2, 85 16V 1.2, 90 1.6		<b>F8-5937</b>		H=195
Repair Kit, wheel suspension	All Models		<b>F8-6279</b>		
Bearing Bush, stabiliser	All Models		<b>F8-6731</b>		
Engine Mounting	1.4 GT Turbo, 1.7 TD		<b>F8-6917</b>		
Holder, engine mounting	55 1.1, 60 1.2, 75 1.2, 85 16V 1.2		<b>F8-7012</b>		
Holder, engine mounting	60 1.2	01/1997 →;  176 B4.000	<b>F8-7012</b>		
Holder, engine mounting	1.4 GT Turbo, 55 1.1, 75 1.2, 85 16V 1.2		<b>F8-7013</b>		
Holder, engine mounting	1.7 D, 60 1.2, 90 1.6		<b>F8-7013</b>		
Holder, engine mounting	60 1.2	176 B4.000;	<b>F8-7013</b>		
Mounting, axle beam	1.4 GT Turbo, 1.7 TD, 55 1.1, 60 1.2, 75 1.2, 90 1.6		<b>F8-7020</b>		H=48; d=15; D=60,2
Belt Pulley, crankshaft	60 1.2, 75 1.2, 85 16V 1.2		<b>F8-7648</b>		
Control Arm-/Trailing Arm Bush	1.7 TD, 55 1.1, 60 1.2, 60 TD 1.7, 75 1.2, 85 16V 1.2, 90 1.6		<b>G9-533</b>		H=55; D1=32; D2=38
Control Arm-/Trailing Arm Bush	All Models		<b>G9-584</b>		
Control Arm-/Trailing Arm Bush	All Models		<b>G9-612</b>		
<b>PUNTO Convertible (176C)</b>			<b>04/1994 → 06/2000</b>		
Anti-Friction Bearing	60 1.2, 90 1.6		<b>F8-3013</b>		H=7; d=49; D=71
Top Strut Mounting	All Models		<b>F8-5858</b>		
Mounting, axle beam	All Models		<b>F8-5864</b>		H=29; d=16; D=72
Rubber Buffer, suspension	60 1.2, 85 16V 1.2		<b>F8-5937</b>		H=195
Rubber Buffer, suspension	90 1.6		<b>F8-5937</b>		H=195
Bearing Bush, stabiliser	All Models		<b>F8-6731</b>		
Holder, engine mounting	60 1.2	176 B4.000	<b>F8-7012</b>		
Holder, engine mounting	60 1.2, 85 16V 1.2		<b>F8-7012</b>		
Holder, engine mounting	60 1.2	176 B4.000;	<b>F8-7013</b>		
Holder, engine mounting	60 1.2, 85 16V 1.2, 90 1.6		<b>F8-7013</b>		
Mounting, axle beam	60 1.2, 90 1.6		<b>F8-7020</b>		H=48; d=15; D=60,2
Belt Pulley, crankshaft	60 1.2		<b>F8-7648</b>		
Control Arm-/Trailing Arm Bush	All Models		<b>G9-533</b>		H=55; D1=32; D2=38
Control Arm-/Trailing Arm Bush	All Models		<b>G9-584</b>		
Control Arm-/Trailing Arm Bush	All Models		<b>G9-612</b>		

<b>F8-3013</b>	<b>F8-5858</b>	<b>F8-5864</b>	<b>F8-5937</b>	<b>F8-6279</b>	<b>F8-6731</b>	<b>F8-6917</b>
Ref.Nr.: 503517	Ref.Nr.: 07775940	Ref.Nr.: 46476755	Ref.Nr.: 07762158	Ref.Nr.:	Ref.Nr.: 7750990	Ref.Nr.: 7748666
<b>F8-7012</b>	<b>F8-7013</b>	<b>F8-7020</b>	<b>F8-7648</b>	<b>G9-533</b>	<b>G9-584</b>	<b>G9-612</b>
Ref.Nr.: 46439876	Ref.Nr.: 7737417	Ref.Nr.: 7756218	Ref.Nr.: 7778028	Ref.Nr.: 7673581	Ref.Nr.: 7775344R	Ref.Nr.: 7775343

**Article Description****Article Nr.****Fitting Position****PUNTO Van (176L)****04/1996 → 02/2000**

Anti-Friction Bearing	1.1, 1.7 D, 1.7 TD		<b>F8-3013</b>		H=7; d=49; D=71
Engine Mounting	1.7 D, 1.7 TD		<b>F8-5414</b>		
Top Strut Mounting	1.1, 1.7 D, 1.7 TD		<b>F8-5858</b>		
Mounting, axle beam	1.1, 1.7 D, 1.7 TD		<b>F8-5864</b>		H=29; d=16; D=72
Rubber Buffer, suspension	1.1, 1.7 D, 1.7 TD		<b>F8-5937</b>		H=195
Repair Kit, wheel suspension	1.1, 1.7 D, 1.7 TD		<b>F8-6279</b>		
Bearing Bush, stabiliser	1.1, 1.7 D, 1.7 TD		<b>F8-6731</b>		
Engine Mounting	1.7 TD		<b>F8-6917</b>		
Holder, engine mounting	1.1		<b>F8-7012</b>		
Holder, engine mounting	1.1		<b>F8-7013</b>		
Holder, engine mounting	1.7 D		<b>F8-7013</b>		
Control Arm-/Trailing Arm Bush	1.1, 1.7 D, 1.7 TD		<b>G9-584</b>		
Control Arm-/Trailing Arm Bush	1.1, 1.7 D, 1.7 TD		<b>G9-612</b>		

**PUNTO (188)****09/1999 →**

Dust Cover Kit, shock absorber	1.2 16V 80 , 1.2 60 , 1.2 Natural Power, 1.3 JTD 16V, 1.4, 1.8 130 HGT , 1.9 DS 60 , 1.9 JTD, 1.9 JTD 80		<b>AK-735350</b>		
Alternator Freewheel Clutch	1.9 DS 60 , 1.9 JTD, 1.9 JTD 80		<b>F5-1005</b>		
Alternator Freewheel Clutch	1.3 JTD 16V		<b>F5-1045</b>		
Alternator Freewheel Clutch	1.9 JTD		<b>F5-1098</b>		
Alternator Freewheel Clutch	1.9 DS 60 , 1.9 JTD, 1.9 JTD 80		<b>F5-1123</b>		
Control Arm-/Trailing Arm Bush	1.2 16V 80 , 1.2 60 , 1.2 Natural Power, 1.3 JTD 16V, 1.4, 1.8 130 HGT , 1.9 DS 60 , 1.9 JTD, 1.9 JTD 80		<b>F8-6052</b>		
Control Arm-/Trailing Arm Bush	1.2 16V 80 , 1.2 60 , 1.2 Natural Power, 1.3 JTD 16V, 1.4, 1.8 130 HGT , 1.9 DS 60 , 1.9 JTD, 1.9 JTD 80		<b>F8-6053</b>		
Anti-Friction Bearing	1.2 16V 80		<b>F8-6266</b>		
Anti-Friction Bearing	1.4		<b>F8-6266</b>		
Anti-Friction Bearing	1.8 130 HGT , 1.9 DS 60 , 1.9 JTD, 1.9 JTD 80		<b>F8-6266</b>		
Top Strut Mounting	1.2 16V 80 , 1.2 60 , 1.2 Natural Power, 1.3 JTD 16V, 1.4		<b>F8-6286</b>		
Top Strut Mounting	1.2 16V 80 , 1.2 60 , 1.2 Natural Power, 1.3 JTD 16V, 1.4, 1.8 130 HGT , 1.9 DS 60 , 1.9 JTD, 1.9 JTD 80		<b>F8-6287</b>		
Top Strut Mounting	1.8 130 HGT , 1.9 DS 60 , 1.9 JTD, 1.9 JTD 80		<b>F8-6288</b>		
Belt Pulley, crankshaft	1.9 JTD, 1.9 JTD 80	Number of Ribs: 5; Parameter: 6PK; with screw set	<b>F8-6393</b>		D=169
Spring Cap	1.2 16V 80 , 1.2 60 , 1.2 Natural Power, 1.3 JTD 16V, 1.4, 1.8 130 HGT , 1.9 DS 60 , 1.9 JTD, 1.9 JTD 80		<b>F8-6560</b>		

<b>AK-735350</b>	<b>F5-1005</b>	<b>F5-1045</b>	<b>F5-1098</b>	<b>F5-1123</b>	<b>F8-3013</b>	<b>F8-5414</b>
Ref.Nr.: 46531017	Ref.Nr.: 9951162	Ref.Nr.: 77362721	Ref.Nr.: 77364725	Ref.Nr.: 9948513	Ref.Nr.: 503517	Ref.Nr.: 46431619
<b>F8-5858</b>	<b>F8-5864</b>	<b>F8-5937</b>	<b>F8-6052</b>	<b>F8-6053</b>	<b>F8-6266</b>	<b>F8-6279</b>
Ref.Nr.: 07775940	Ref.Nr.: 46476755	Ref.Nr.: 07762158	Ref.Nr.: 46545661S	Ref.Nr.: 46545661S1	Ref.Nr.: 5035C2	Ref.Nr.:
<b>F8-6286</b>	<b>F8-6287</b>	<b>F8-6288</b>	<b>F8-6393</b>	<b>F8-6560</b>	<b>F8-6561</b>	<b>F8-6731</b>
Ref.Nr.: 46746544	Ref.Nr.: 46746548	Ref.Nr.: 50702206	Ref.Nr.: 55196301	Ref.Nr.: 46541086	Ref.Nr.: 46750910	Ref.Nr.: 7750990

Article Description



Article Nr.

Fitting Position



<b>PUNTO (188)</b>			<b>09/1999 →</b>		
Spring Cap	1.2 16V 80, 1.2 60, 1.4, 1.8 130 HGT, 1.9 DS 60, 1.9 JTD 80		<b>F8-6561</b>		
Bearing Bush, stabiliser	1.2 16V 80, 1.2 60, 1.2 Natural Power, 1.3 JTD 16V, 1.4, 1.8 130 HGT, 1.9 DS 60, 1.9 JTD, 1.9 JTD 80		<b>F8-6731</b>		
Belt Pulley, crankshaft	1.9 DS 60	Number of Ribs: 6	<b>F8-7085</b>		Belt Pulley Ø [mm]=168; W=35.5
Belt Pulley, crankshaft	1.3 JTD 16V	07/2003 →; Number of Ribs: 6	<b>F8-7086</b>		Belt Pulley Ø [mm]=165; Mounting points diam.[mm]=35; W=30
Rubber Buffer, suspension	1.2 16V 80, 1.2 60, 1.2 Natural Power, 1.3 JTD 16V, 1.4, 1.8 130 HGT, 1.9 DS 60, 1.9 JTD, 1.9 JTD 80		<b>F8-7593</b>		H=212
Rubber Buffer, suspension	1.2 16V 80, 1.2 60, 1.2 Natural Power, 1.3 JTD 16V, 1.4, 1.8 130 HGT, 1.9 DS 60, 1.9 JTD, 1.9 JTD 80	with accessories	<b>F8-7596</b>		
Mounting, manual transmission	1.2 16V 80, 1.2 60, 1.2 Bifuel, 1.2 Natural Power		<b>F8-8086</b>		
Mounting, manual transmission	1.4		<b>F8-8086</b>		

<b>PUNTO Van (188AX)</b>			<b>02/2000 → 10/2009</b>		
Alternator Freewheel Clutch	1.9 JTD		<b>F5-1005</b>		
Alternator Freewheel Clutch	1.3 JTD		<b>F5-1045</b>		
Alternator Freewheel Clutch	1.9 D 60, 1.9 JTD		<b>F5-1123</b>		
Control Arm-/Trailing Arm Bush	1.2 60, 1.9 D 60, 1.9 JTD		<b>F8-6052</b>		
Control Arm-/Trailing Arm Bush	1.2 60, 1.9 D 60, 1.9 JTD		<b>F8-6053</b>		
Anti-Friction Bearing	1.2 60		<b>F8-6266</b>		
Anti-Friction Bearing	1.9 D 60, 1.9 JTD		<b>F8-6266</b>		
Top Strut Mounting	1.2 60		<b>F8-6286</b>		
Top Strut Mounting	1.2 60, 1.9 D 60, 1.9 JTD		<b>F8-6287</b>		
Top Strut Mounting	1.9 D 60, 1.9 JTD		<b>F8-6288</b>		
Belt Pulley, crankshaft	1.9 JTD	Number of Ribs: 5; Parameter: 6PK; with screw set	<b>F8-6393</b>		D=169
Spring Cap	1.2 60, 1.9 D 60, 1.9 JTD		<b>F8-6560</b>		
Spring Cap	1.2 60, 1.3 JTD, 1.9 D 60, 1.9 JTD		<b>F8-6561</b>		
Bearing Bush, stabiliser	1.2 60, 1.9 D 60, 1.9 JTD		<b>F8-6731</b>		
Belt Pulley, crankshaft	1.9 D 60	Number of Ribs: 6	<b>F8-7085</b>		Belt Pulley Ø [mm]=168; W=35.5
Belt Pulley, crankshaft	1.3 JTD	07/2003 →; Number of Ribs: 6	<b>F8-7086</b>		Belt Pulley Ø [mm]=165; Mounting points diam.[mm]=35; W=30
Rubber Buffer, suspension	1.2 60, 1.3 JTD, 1.9 D 60, 1.9 JTD		<b>F8-7593</b>		H=212
Mounting, manual transmission	1.2 60		<b>F8-8086</b>		

<b>AK-735343</b>	<b>F5-1005</b>	<b>F5-1045</b>	<b>F5-1123</b>	<b>F8-6052</b>	<b>F8-6053</b>	<b>F8-6266</b>
Ref.Nr.: 51775545	Ref.Nr.: 9951162	Ref.Nr.: 77362721	Ref.Nr.: 9948513	Ref.Nr.: 46545661S	Ref.Nr.: 46545661S1	Ref.Nr.: 5035C2
<b>F8-6286</b>	<b>F8-6287</b>	<b>F8-6288</b>	<b>F8-6393</b>	<b>F8-6560</b>	<b>F8-6561</b>	<b>F8-6731</b>
Ref.Nr.: 46746544	Ref.Nr.: 46746548	Ref.Nr.: 50702206	Ref.Nr.: 55196301	Ref.Nr.: 46541086	Ref.Nr.: 46750910	Ref.Nr.: 7750990
<b>F8-7085</b>	<b>F8-7086</b>	<b>F8-7593</b>	<b>F8-7596</b>	<b>F8-8086</b>		
Ref.Nr.: 46770939	Ref.Nr.: 55200498	Ref.Nr.: 46531017	Ref.Nr.: 46529067	Ref.Nr.: 46528871		



**Article Description****Article Nr.****Fitting Position**

<b>GRANDE PUNTO (199)</b>		<b>10/2005 → 07/2012</b>	
Dust Cover Kit, shock absorber	1.2, 1.3 D Multijet, 1.4, 1.4 16V, 1.4 T-Jet, 1.9 D Multijet	<b>AK-735343</b>	
Dust Cover Kit, shock absorber	1.2, 1.3 D Multijet, 1.4, 1.4 16V, 1.4 T-Jet, 1.9 D Multijet	<b>AK-735344</b>	
Alternator Freewheel Clutch	1.3 D Multijet	<b>F5-1037</b>	
Alternator Freewheel Clutch	1.3 D Multijet	<b>F5-1041</b>	
Alternator Freewheel Clutch	1.3 D Multijet	<b>F5-1045</b>	
Alternator Freewheel Clutch	1.6 D Multijet, 1.9 D Multijet	<b>F5-1098</b>	
Alternator Freewheel Clutch	1.6 D Multijet, 1.9 D Multijet	<b>F5-1123</b>	
Engine Mounting	1.3 D Multijet	<b>F8-6616</b>	
Engine Mounting	1.3 D Multijet	<b>F8-6617</b>	not for  5-speed
Engine Mounting	1.2, 1.4, 1.4 16V	<b>F8-6618</b>	
Engine Mounting	1.2, 1.4, 1.4 16V	<b>F8-6619</b>	
Engine Mounting	1.2, 1.4, 1.4 16V	<b>F8-6620</b>	
Engine Mounting	1.3 D Multijet	<b>F8-6621</b>	
Engine Mounting	1.3 D Multijet	<b>F8-6621</b>	
Engine Mounting	1.3 D Multijet	<b>F8-6622</b>	
Engine Mounting	1.3 D Multijet	<b>F8-6623</b>	
Engine Mounting	1.3 D Multijet	<b>F8-6623</b>	
Belt Pulley, crankshaft	1.3 D Multijet	<b>F8-7086</b>	Number of Ribs: 6
Top Strut Mounting	1.2, 1.3 D Multijet, 1.4, 1.4 16V, 1.4 LPG, 1.4 Natural Power, 1.4 T-Jet, 1.6 D Multijet, 1.9 D Multijet	<b>F8-7421</b>	
Spring Cap	1.2, 1.3 D Multijet, 1.4, 1.4 16V, 1.4 LPG, 1.4 Natural Power, 1.4 T-Jet, 1.6 D Multijet, 1.9 D Multijet	<b>F8-7422</b>	
Top Strut Mounting	1.2, 1.3 D Multijet, 1.4, 1.4 16V, 1.4 LPG, 1.4 Natural Power, 1.4 T-Jet, 1.6 D Multijet, 1.9 D Multijet	<b>F8-7423</b>	
Top Strut Mounting	1.2, 1.3 D Multijet, 1.4, 1.4 16V, 1.4 LPG, 1.4 Natural Power, 1.4 T-Jet, 1.6 D Multijet, 1.9 D Multijet	<b>F8-7424</b>	
Belt Pulley, crankshaft	1.3 D Multijet	<b>F8-7647</b>	Number of grooves: 4, 6; Number of Ribs: 3, 5; Parameter: 4PK+6PK
Protective Cap/Bellow, shock absorber	1.2, 1.2 LPG, 1.3 D Multijet, 1.4, 1.4 16V, 1.4 Natural Power, 1.4 T-Jet, 1.6 D Multijet, 1.9 D Multijet	<b>F8-7663</b>	
Control Arm-/Trailing Arm Bush	1.2, 1.3 D Multijet, 1.4, 1.4 16V, 1.4 LPG, 1.4 Natural Power, 1.4 T-Jet, 1.6 D Multijet, 1.9 D Multijet	<b>F8-7995</b>	
<b>PUNTO (199)</b>		<b>03/2012 →</b>	
Alternator Freewheel Clutch	1.3 Multijet	<b>F5-1041</b>	
Alternator Freewheel Clutch	1.3 Multijet	<b>F5-1045</b>	

<b>AK-735343</b>	<b>AK-735344</b>	<b>F5-1037</b>	<b>F5-1041</b>	<b>F5-1045</b>	<b>F5-1098</b>	<b>F5-1123</b>
Ref.Nr.: 51775545	Ref.Nr.: 55701429	Ref.Nr.: 77363954	Ref.Nr.: 77364723	Ref.Nr.: 77362721	Ref.Nr.: 77364725	Ref.Nr.: 9948513
<b>F8-6616</b>	<b>F8-6617</b>	<b>F8-6618</b>	<b>F8-6619</b>	<b>F8-6620</b>	<b>F8-6621</b>	<b>F8-6622</b>
Ref.Nr.: 55700440	Ref.Nr.: 55700442	Ref.Nr.: 55700431	Ref.Nr.: 55700434	Ref.Nr.: 55700441	Ref.Nr.: 55702836	Ref.Nr.: 55700435
<b>F8-6623</b>	<b>F8-7086</b>	<b>F8-7421</b>	<b>F8-7422</b>	<b>F8-7423</b>	<b>F8-7424</b>	<b>F8-7647</b>
Ref.Nr.: 55702833	Ref.Nr.: 55200498	Ref.Nr.: 51813225	Ref.Nr.: 344963	Ref.Nr.: 55701902	Ref.Nr.: 55703318	Ref.Nr.: 55182506

Article Description



Article Nr.

Fitting Position



<b>PUNTO (199)</b>		<b>03/2012 →</b>	
Control Arm-/Trailing Arm Bush	0.9 Bifuel, 0.9 Twinair Turbo, 1.2, 1.3 Multijet, 1.4, 1.4 Multi Air, 1.4 Natural Power, 1.4 Turbo Multi Air	F8-7995	
<b>PUNTO EVO (199)</b>		<b>07/2008 → 02/2012</b>	
Alternator Freewheel Clutch	1.3 D Multijet	F5-1041	
Alternator Freewheel Clutch	1.3 D Multijet	F5-1045	
Alternator Freewheel Clutch	1.6 D Multijet	F5-1098	
Top Strut Mounting	1.2, 1.3 D Multijet, 1.4, 1.4 16V, 1.4 Natural Power, 1.6 D Multijet	F8-7421	
Spring Cap	1.2, 1.3 D Multijet, 1.4, 1.4 16V, 1.4 Natural Power, 1.6 D Multijet	F8-7422	
Top Strut Mounting	1.2, 1.3 D Multijet, 1.4, 1.4 16V, 1.4 Natural Power, 1.6 D Multijet	F8-7423	
Top Strut Mounting	1.2, 1.3 D Multijet, 1.4, 1.4 16V, 1.4 Natural Power, 1.6 D Multijet	F8-7424	
Protective Cap/Bellow, shock absorber	1.2, 1.3 D Multijet, 1.4, 1.4 16V, 1.4 LPG, 1.4 Natural Power, 1.6 D Multijet	F8-7663	H=205
Control Arm-/Trailing Arm Bush	1.2, 1.3 D Multijet, 1.4, 1.4 16V, 1.4 Natural Power, 1.6 D Multijet	F8-7995	
<b>QUBO (225)</b>		<b>02/2008 →</b>	
Alternator Freewheel Clutch	1.3 D Multijet	F5-1041	
Belt Pulley, crankshaft	1.4 KfV; Number of Ribs: 5; Parameter: 6PK	F8-6394	H=25; d=44.05; Mounting points diam.[mm]=9; D=148; D1=142.9
Engine Mounting	1.3 D Multijet, 1.4	F8-6615	
Engine Mounting	1.3 D Multijet	F8-6624	Ver.: Cambio robotizzato, Selespeed
Engine Mounting	1.3 D Multijet	F8-6630	
Top Strut Mounting	1.3 D Multijet, 1.4, 1.4 Natural Power	F8-7428	
Top Strut Mounting	1.3 D Multijet, 1.4, 1.4 Natural Power	F8-7429	
Belt Pulley, crankshaft	1.3 D Multijet Number of grooves: 4, 6; Number of Ribs: 3, 5; Parameter: 4PK+6PK	F8-7647	d=35.03; Mounting points diam.[mm]=8.5; D1=164.9; D2=145
Protective Cap/Bellow, shock absorber	1.3 D Multijet, 1.4, 1.4 Natural Power	F8-7663	H=205
Control Arm-/Trailing Arm Bush	1.3 D Multijet, 1.4, 1.4 Natural Power	F8-7995	
<b>REGATA (138)</b>		<b>09/1983 → 12/1990</b>	
Dust Cover Kit, shock absorber	All Models	AK-735005	
Dust Cover Kit, shock absorber	All Models	AK-735097	
Anti-Friction Bearing	All Models	F8-3017	d=50; D=70
Top Strut Mounting	All Models	F8-5927	
Engine Mounting	70 1.3, 75 1.5, 75 i.e. 1.5, 85 1.5, 85 1.6, 85 Super 1.5	F8-6912	

<b>AK-735005</b>	<b>AK-735097</b>	<b>F5-1041</b>	<b>F5-1045</b>	<b>F5-1098</b>	<b>F8-3017</b>	<b>F8-5927</b>
Ref.Nr.:	Ref.Nr.:	Ref.Nr.: 77364723	Ref.Nr.: 77362721	Ref.Nr.: 77364725	Ref.Nr.: 4400895	Ref.Nr.: 7537167
<b>F8-6394</b>	<b>F8-6615</b>	<b>F8-6624</b>	<b>F8-6630</b>	<b>F8-6912</b>	<b>F8-6928</b>	<b>F8-7421</b>
Ref.Nr.: 0515.R8	Ref.Nr.: 51761609	Ref.Nr.: 51782560	Ref.Nr.: 51799110	Ref.Nr.: 4433965	Ref.Nr.: 4433964	Ref.Nr.: 51813225
<b>F8-7422</b>	<b>F8-7423</b>	<b>F8-7424</b>	<b>F8-7428</b>	<b>F8-7429</b>	<b>F8-7647</b>	<b>F8-7663</b>
Ref.Nr.: 344963	Ref.Nr.: 55701902	Ref.Nr.: 55703318	Ref.Nr.: 5038J8	Ref.Nr.: 5038G8	Ref.Nr.: 55182506	Ref.Nr.: 344435

**Article Description****Article Nr.****Fitting Position**

<b>REGATA (138)</b>		<b>09/1983 → 12/1990</b>	
Engine Mounting	70 1.3, 75 1.5, 75 i.e. 1.5, 85 1.5, 85 1.6, 85 Super 1.5	<b>F8-6928</b>	⊕
<b>REGATA Weekend (138)</b>		<b>01/1984 → 12/1990</b>	
Dust Cover Kit, shock absorber	All Models	<b>AK-735005</b>	⊕ ⊕ ⊕
Dust Cover Kit, shock absorber	All Models	<b>AK-735097</b>	⊕
Anti-Friction Bearing	All Models	<b>F8-3017</b>	⊕ ⊕ ⊕ d=50; D=70
Top Strut Mounting	All Models	<b>F8-5927</b>	⊕ ⊕ ⊕
Engine Mounting	70 1.3, 75 1.5, 90 i.e. 1.6	<b>F8-6912</b>	
Engine Mounting	75 1.5, 90 i.e. 1.6	<b>F8-6928</b>	⊕
<b>STRADA Convertible (138_)</b>		<b>01/1980 → 07/1989</b>	
Dust Cover Kit, shock absorber	85 1.5	<b>AK-735005</b>	⊕ ⊕ ⊕
Dust Cover Kit, shock absorber	100 1.6, 50 1.3, 85 1.5	<b>AK-735097</b>	⊕
Anti-Friction Bearing	100 1.6, 50 1.3, 85 1.5	<b>F8-3017</b>	⊕ ⊕ ⊕ d=50; D=70
<b>STRADA (138A)</b>		<b>01/1978 → 12/1987</b>	
Dust Cover Kit, shock absorber	105 Sport 1.6, 55 Diesel 1.7, 60 1.0, 65 1.3, 75 1.3, 75 i.e. 1.5, 85 1.5	<b>AK-735005</b>	⊕ ⊕ ⊕
Dust Cover Kit, shock absorber	105 Sport 1.6, 55 Diesel 1.7, 60 1.0, 65 1.3, 70 1.3, 75 1.3, 75 1.5, 75 i.e. 1.5, 85 1.5, 90 i.e. 1.6	<b>AK-735097</b>	⊕
Anti-Friction Bearing	105 Sport 1.6, 55 Diesel 1.7, 60 1.0, 65 1.3, 75 1.3, 75 1.5, 75 i.e. 1.5, 85 1.5	<b>F8-3017</b>	⊕ ⊕ ⊕ d=50; D=70
Top Strut Mounting	All Models	<b>F8-5927</b>	⊕ ⊕ ⊕
Top Strut Mounting	105 Sport 1.6, 55 Diesel 1.7, 60 1.0, 65 1.3, 75 1.3, 75 1.5, 85 1.5	<b>F8-5957</b>	⊕ ⊕ ⊕
Top Strut Mounting	105 Sport 1.6, 125 TC Abarth 2.0, 55 Diesel 1.7, 60 1.0, 65 1.3, 75 1.3, 75 1.5, 85 1.5	<b>F8-5958</b>	⊕ ⊕ ⊕
Engine Mounting	60 1.0, 65 1.3, 75 1.3, 75 1.5, 85 1.5	<b>F8-6912</b>	
Engine Mounting	60 1.0, 65 1.3, 75 1.3, 75 1.5, 85 1.5	<b>F8-6928</b>	⊕
<b>STRADA Mk II (138A)</b>		<b>10/1982 → 12/1988</b>	
Dust Cover Kit, shock absorber	105 1.6, 60 1.1, 60 Diesel 1.7, 70 1.3, 75 1.5 CAT, 80 Turbo Diesel 1.9, 85 1.5	<b>AK-735005</b>	⊕ ⊕ ⊕
Dust Cover Kit, shock absorber	100 1.6, 105 1.6, 60 1.1, 60 Diesel 1.7, 70 1.3, 75 1.5, 75 1.5 CAT, 80 Turbo Diesel 1.9, 85 1.5, 90 1.6 i.e.	<b>AK-735097</b>	⊕
Anti-Friction Bearing	100 1.6, 105 1.6, 60 1.1, 60 Diesel 1.7, 70 1.3, 75 1.5, 75 1.5 CAT, 80 Turbo Diesel 1.9, 85 1.5, 90 1.6 i.e.	<b>F8-3017</b>	⊕ ⊕ ⊕ d=50; D=70
Top Strut Mounting	All Models	<b>F8-5927</b>	⊕ ⊕ ⊕
Top Strut Mounting	60 1.1	<b>F8-5958</b>	⊕ ⊕ ⊕
<b>SCUDO Combinato (220P)</b>		<b>02/1996 → 12/2006</b>	
Dust Cover Kit, shock absorber	1.6, 1.9 D, 1.9 TD, 1.9 TD Eco, 2.0 16V, 2.0 JTD	<b>AK-735091</b>	⊕ ⊕ ⊕
Alternator Freewheel Clutch	2.0 JTD, 2.0 JTD 16V	<b>F5-1020</b>	



**AK-735005**  
Ref.Nr.:



**AK-735091**  
Ref.Nr.: 503339



**AK-735097**  
Ref.Nr.:



**F5-1020**  
Ref.Nr.: 31771-68D01



**F5-1046**  
Ref.Nr.: 30667687



**F8-3017**  
Ref.Nr.: 4400895



**F8-5927**  
Ref.Nr.: 7537167



**F8-5957**  
Ref.Nr.: SE141156228A



**F8-5958**  
Ref.Nr.: 7635775



**F8-6912**  
Ref.Nr.: 4433965



**F8-6928**  
Ref.Nr.: 4433964

Article Description



Article Nr.

Fitting Position



### SCUDO Combinato (220P)

02/1996 → 12/2006

Alternator Freewheel Clutch	1.9 D, 2.0 JTD, 2.0 JTD 16V		<b>F5-1046</b>		
Anti-Friction Bearing	1.6, 1.9 D, 1.9 TD, 1.9 TD Eco, 2.0 16V, 2.0 JTD		<b>F8-3014</b>		H1=24; H2=46; d1=78; d2=84; D=128
Engine Mounting	1.6, 1.9 D, 1.9 TD, 1.9 TD Eco		<b>F8-5026</b>		d=10; D=70; Thick. [mm]=40, 53
Stabiliser Mounting	1.6, 1.9 D, 1.9 TD, 1.9 TD Eco		<b>F8-5092</b>		d=24
Engine Mounting	1.6, 1.9 D, 1.9 TD, 1.9 TD Eco		<b>F8-5569</b>		
Top Strut Mounting	1.6, 1.9 D, 1.9 TD, 1.9 TD Eco, 2.0 16V, 2.0 JTD		<b>F8-5621</b>		
Top Strut Mounting	1.6, 1.9 D, 1.9 TD, 1.9 TD Eco, 2.0 16V, 2.0 JTD		<b>F8-5622</b>		
Belt Pulley, crankshaft	1.9 D		<b>F8-5636</b>		d=30
Belt Pulley, crankshaft	2.0 JTD		<b>F8-5636</b>		d=30
Belt Pulley, crankshaft	1.9 D, 1.9 TD, 1.9 TD Eco	Number of Ribs: 6	<b>F8-5643</b>		Belt Pulley Ø [mm]=156; W=44
Belt Pulley, crankshaft	1.9 D		<b>F8-5659</b>		
Belt Pulley, crankshaft	1.9 D	Orga.10178→	<b>F8-5660</b>		
Belt Pulley, crankshaft	2.0 JTD	Orga.10180→	<b>F8-5660</b>		
Mounting, axle beam	1.6, 1.9 D, 1.9 TD, 1.9 TD Eco, 2.0 16V, 2.0 JTD		<b>F8-5871</b>		H1=60; H2=48; d=12; D=46
Rubber Buffer, suspension	1.6, 1.9 D, 1.9 TD, 1.9 TD Eco, 2.0 16V, 2.0 JTD		<b>F8-5936</b>		
Control Arm-/Trailing Arm Bush	1.6, 1.9 D, 1.9 TD, 1.9 TD Eco, 2.0 JTD		<b>F8-6153</b>		
Control Arm-/Trailing Arm Bush	1.6, 1.9 D, 1.9 TD, 1.9 TD Eco, 2.0 JTD		<b>F8-6154</b>		
Control Arm-/Trailing Arm Bush	1.6, 1.9 D, 1.9 TD, 1.9 TD Eco, 2.0 JTD		<b>F8-6155</b>		
Engine Mounting	1.6, 1.9 D, 1.9 TD, 1.9 TD Eco, 2.0 JTD		<b>F8-6236</b>		H1=53; H2=40; d=10; D=70
Top Strut Mounting	1.6, 1.9 D, 1.9 TD, 1.9 TD Eco, 2.0 16V, 2.0 JTD		<b>F8-6304</b>		
Control Arm-/Trailing Arm Bush	1.6, 1.9 D, 1.9 TD		<b>F8-6439</b>		H=50; d=22.85; Inner Thread 1=M12 x 1,25 RHT F; Inner Thread 2=M12 x 1,25 RHT F; L=82
Engine Mounting	2.0 JTD		<b>F8-6507</b>		
Engine Mounting	2.0 JTD		<b>F8-6507</b>		
Top Strut Mounting	1.6, 1.9 D, 1.9 TD, 1.9 TD Eco, 2.0 16V, 2.0 JTD		<b>F8-7164</b>		
Engine Mounting	2.0 JTD		<b>F8-8149</b>		
Engine Mounting	1.9 D, 2.0 JTD		<b>F8-8167</b>		
Bellow, steering	1.6, 1.9 D, 1.9 TD, 1.9 TD Eco, 2.0 16V, 2.0 JTD, 2.0 JTD 16V	ch.→0009715; with clamps;	<b>LM-10022S</b>		d1=13; d2=62; L [mm]=210

### SCUDO Box (220L)

02/1996 → 12/2006

Dust Cover Kit, shock absorber	1.6, 1.9 D, 1.9 TD, 2.0, 2.0 JTD		<b>AK-735091</b>		
Alternator Freewheel Clutch	2.0 JTD, 2.0 JTD 16V		<b>F5-1020</b>		

<b>AK-735091</b>	<b>F5-1020</b>	<b>F5-1046</b>	<b>F8-3014</b>	<b>F8-5026</b>	<b>F8-5092</b>	<b>F8-5569</b>
Ref.Nr.: 503339	Ref.Nr.: 31771-68D01	Ref.Nr.: 30667687	Ref.Nr.: 503545	Ref.Nr.: 9606121080	Ref.Nr.: 1305782080	Ref.Nr.: 9604338880
<b>F8-5621</b>	<b>F8-5622</b>	<b>F8-5636</b>	<b>F8-5643</b>	<b>F8-5659</b>	<b>F8-5660</b>	<b>F8-5871</b>
Ref.Nr.: 1311931080	Ref.Nr.: 503868	Ref.Nr.: 0515P2	Ref.Nr.: 96089 38980	Ref.Nr.: 0515Q6	Ref.Nr.: 0515R9	Ref.Nr.: 515261
<b>F8-5936</b>	<b>F8-6153</b>	<b>F8-6154</b>	<b>F8-6155</b>	<b>F8-6236</b>	<b>F8-6304</b>	<b>F8-6439</b>
Ref.Nr.: 5033.39	Ref.Nr.: 3520.G9S1	Ref.Nr.: 3521.C9S	Ref.Nr.: 1316735080S	Ref.Nr.: 1809.21	Ref.Nr.: 1311930080	Ref.Nr.: 1312317080

**Article Description****Article Nr.****Fitting Position**

<b>SCUDO Box (220L)</b>			<b>02/1996 → 12/2006</b>	
Alternator Freewheel Clutch	1.9 D, 2.0 JTD, 2.0 JTD 16V		<b>F5-1046</b>	
Anti-Friction Bearing	All Models		<b>F8-3014</b>	H1=24; H2=46; d1=78; d2=84; D=128
Engine Mounting	1.6, 1.9 D, 1.9 TD		<b>F8-5569</b>	
Top Strut Mounting	1.6, 1.9 D, 1.9 TD, 2.0, 2.0 JTD		<b>F8-5621</b>	
Top Strut Mounting	1.6, 1.9 D, 1.9 TD, 2.0, 2.0 JTD		<b>F8-5622</b>	
Belt Pulley, crankshaft	1.9 D	DW8;	<b>F8-5636</b>	d=30
Belt Pulley, crankshaft	2.0 JTD		<b>F8-5636</b>	d=30
Belt Pulley, crankshaft	1.9 D, 1.9 TD	Number of Ribs: 6	<b>F8-5643</b>	Belt Pulley Ø [mm]=156; W=44
Belt Pulley, crankshaft	1.9 D	DW8;	<b>F8-5659</b>	
Belt Pulley, crankshaft	1.9 D	DW8; Orga.10178→	<b>F8-5660</b>	
Belt Pulley, crankshaft	2.0 JTD	Orga.10180→	<b>F8-5660</b>	
Mounting, axle beam	1.6, 1.9 D, 1.9 TD, 2.0, 2.0 JTD		<b>F8-5871</b>	H1=60; H2=48; d=12; D=46
Rubber Buffer, suspension	1.6, 1.9 D, 1.9 TD, 2.0, 2.0 JTD		<b>F8-5936</b>	
Control Arm-Trailing Arm Bush	1.6, 1.9 D, 1.9 TD, 2.0, 2.0 JTD		<b>F8-6153</b>	
Control Arm-Trailing Arm Bush	1.6, 1.9 D, 1.9 TD, 2.0, 2.0 JTD		<b>F8-6154</b>	
Control Arm-Trailing Arm Bush	1.6, 1.9 D, 1.9 TD, 2.0, 2.0 JTD		<b>F8-6155</b>	
Engine Mounting	1.6, 1.9 D, 1.9 TD, 2.0, 2.0 JTD		<b>F8-6236</b>	H1=53; H2=40; d=10; D=70
Top Strut Mounting	1.6, 1.9 D, 1.9 TD, 2.0, 2.0 JTD		<b>F8-6304</b>	
Control Arm-Trailing Arm Bush	1.6, 1.9 D, 1.9 TD		<b>F8-6439</b>	H=50; d=22.85; Inner Thread 1=M12 x 1,25 RHT F; Inner Thread 2=M12 x 1,25 RHT F; L=82
Engine Mounting	2.0 JTD		<b>F8-6507</b>	
Engine Mounting	2.0 JTD		<b>F8-6507</b>	
Top Strut Mounting	1.6, 1.9 D, 1.9 TD, 2.0, 2.0 JTD		<b>F8-7164</b>	
Engine Mounting	2.0 JTD, 2.0 JTD 16V		<b>F8-8149</b>	
Engine Mounting	1.9 D, 2.0 JTD		<b>F8-8167</b>	
Bellow, steering	All Models	ch.→0009715; with clamps;	<b>LM-10022S</b>	d1=13; d2=62; L [mm]=210
<b>SCUDO (272, 270)</b>			<b>01/2007 →</b>	
Dust Cover Kit, shock absorber	1.6 D Multijet, 2.0 D Multijet		<b>AK-735351</b>	
Alternator Freewheel Clutch	1.6 D Multijet, 2.0 D Multijet		<b>F5-1046</b>	
Anti-Friction Bearing	2.0 D Multijet		<b>F8-3014</b>	H1=24; H2=46; d1=78; d2=84; D=128
Belt Pulley, crankshaft	1.6 D Multijet	Number of Ribs: 5; Parameter: 6PK	<b>F8-7645</b>	D=157.75

<b>AK-735351</b>	<b>F5-1046</b>	<b>F8-3014</b>	<b>F8-5569</b>	<b>F8-5621</b>	<b>F8-5622</b>	<b>F8-5636</b>
Ref.Nr.: 1311716080	Ref.Nr.: 30667687	Ref.Nr.: 503545	Ref.Nr.: 9604338880	Ref.Nr.: 1311931080	Ref.Nr.: 503868	Ref.Nr.: 0515P2
<b>F8-5643</b>	<b>F8-5659</b>	<b>F8-5660</b>	<b>F8-5871</b>	<b>F8-5936</b>	<b>F8-6153</b>	<b>F8-6154</b>
Ref.Nr.: 96089 38980	Ref.Nr.: 0515Q6	Ref.Nr.: 0515R9	Ref.Nr.: 515261	Ref.Nr.: 5033.39	Ref.Nr.: 3520.G9S1	Ref.Nr.: 3521.C9S
<b>F8-6155</b>	<b>F8-6236</b>	<b>F8-6304</b>	<b>F8-6439</b>	<b>F8-6507</b>	<b>F8-7164</b>	<b>F8-7645</b>
Ref.Nr.: 1316735080S	Ref.Nr.: 1809.21	Ref.Nr.: 1311930080	Ref.Nr.: 1312317080	Ref.Nr.: 1827.16	Ref.Nr.: 503555	Ref.Nr.: 0515.T3

Article Description

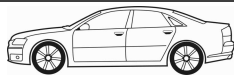

Article Nr.

Fitting Position



<b>SCUDO (272, 270)</b>			<b>01/2007 →</b>		
Belt Pulley, crankshaft	2.0 D Multijet		<b>F8-7861</b>		
Engine Mounting	2.0 D Multijet		<b>F8-8149</b>	⊕	
Engine Mounting	1.6 D Multijet, 2.0 D Multijet, 2.0 D Multijet 4x4		<b>F8-8167</b>	⊕	
<b>SCUDO Box (272, 270)</b>			<b>01/2007 →</b>		
Dust Cover Kit, shock absorber	1.6 D Multijet, 2.0 D Multijet		<b>AK-735351</b>	⊕ ⊕ ⊕	
Alternator Freewheel Clutch	1.6 D Multijet, 2.0 D Multijet		<b>F5-1046</b>		
Anti-Friction Bearing	2.0 D Multijet		<b>F8-3014</b>	⊕	H1=24; H2=46; d1=78; d2=84; D=128
Belt Pulley, crankshaft	1.6 D Multijet	Number of Ribs: 5; Parameter: 6PK	<b>F8-7645</b>		D=157.75
Belt Pulley, crankshaft	2.0 D Multijet		<b>F8-7861</b>		
Engine Mounting	2.0 D Multijet, 2.0 D Multijet 4x4		<b>F8-8149</b>	⊕	
Engine Mounting	1.6 D Multijet, 2.0 D Multijet, 2.0 D Multijet 4x4		<b>F8-8167</b>	⊕	
<b>SCUDO Platform/Chassis (272, 270)</b>			<b>01/2007 →</b>		
Dust Cover Kit, shock absorber	1.6 D Multijet, 2.0 D Multijet		<b>AK-735351</b>	⊕ ⊕ ⊕	
Alternator Freewheel Clutch	1.6 D Multijet, 2.0 D Multijet		<b>F5-1046</b>		
Anti-Friction Bearing	2.0 D Multijet		<b>F8-3014</b>	⊕	H1=24; H2=46; d1=78; d2=84; D=128
Belt Pulley, crankshaft	1.6 D Multijet	Number of Ribs: 5; Parameter: 6PK	<b>F8-7645</b>		D=157.75
Belt Pulley, crankshaft	2.0 D Multijet		<b>F8-7861</b>		
Engine Mounting	2.0 D Multijet		<b>F8-8149</b>	⊕	
Engine Mounting	1.6 D Multijet, 2.0 D Multijet		<b>F8-8167</b>	⊕	
<b>SEDICI (FY_)</b>			<b>06/2006 →</b>		
Dust Cover Kit, shock absorber	1.6 16V, 1.6 16V 4x4, 1.9 D Multijet 4x4		<b>AK-735352</b>	⊕ ⊕ ⊕	
Alternator Freewheel Clutch	1.9 D Multijet, 1.9 D Multijet 4x4		<b>F5-1123</b>		
Control Arm-/Trailing Arm Bush	All Models		<b>F8-6448</b>	⊕ ⊕ ⊕	
Control Arm-/Trailing Arm Bush	All Models		<b>F8-6449</b>	⊕ ⊕ ⊕	
<b>SEICENTO / 600 (187)</b>			<b>01/1998 → 01/2010</b>		
Dust Cover Kit, shock absorber	0.9 , 1.1		<b>AK-735116</b>	⊕ ⊕ ⊕	
Top Strut Mounting	0.9 , 1.1 , Elettrica	⊕	<b>F8-5598</b>	⊕ ⊕ ⊕	
Engine Mounting	0.9		<b>F8-6896</b>	⊕	H=54; d=11; D=69
Engine Mounting	0.9 , 1.1		<b>F8-6932</b>	⊕	
Engine Mounting	0.9 , 1.1		<b>F8-6934</b>		H=58; d=11; D=74
Control Arm-/Trailing Arm Bush	0.9 , 1.1 , Elektra		<b>G9-533</b>	⊕ ⊕ ⊕	H=55; D1=32; D2=38

<b>AK-735116</b>	<b>AK-735351</b>	<b>AK-735352</b>	<b>F5-1046</b>	<b>F5-1123</b>	<b>F8-3014</b>	<b>F8-5598</b>
Ref.Nr.:	Ref.Nr.: 1311716080	Ref.Nr.: 71742685	Ref.Nr.: 30667687	Ref.Nr.: 9948513	Ref.Nr.: 503545	Ref.Nr.: 7667087
<b>F8-6448</b>	<b>F8-6449</b>	<b>F8-6896</b>	<b>F8-6932</b>	<b>F8-6934</b>	<b>F8-7645</b>	<b>F8-7861</b>
Ref.Nr.: 45261-79J00	Ref.Nr.: 45201-79J00	Ref.Nr.: 46749600	Ref.Nr.: 46514433	Ref.Nr.: 46765087	Ref.Nr.: 0515.T3	Ref.Nr.: 0515 Q8
<b>F8-8149</b>	<b>F8-8167</b>	<b>G9-533</b>	<b>G9-534</b>			
Ref.Nr.: 1844.93	Ref.Nr.: 9631575180	Ref.Nr.: 7673581	Ref.Nr.: 5927293			

**Article Description****Article Nr.****Fitting Position**

<b>SEICENTO / 600 (187)</b>			<b>01/1998 → 01/2010</b>		
Control Arm-/Trailing Arm Bush	0.9 , 1.1 , Elektra		<b>G9-534</b>		H=58; d1=5; d2=22; W=42
<b>SEICENTO / 600 Van (287)</b>			<b>01/1998 → 01/2010</b>		
Top Strut Mounting	1.1		<b>F8-5598</b>		
Engine Mounting	0.9		<b>F8-6896</b>		H=54; d=11; D=69
<b>SIENA (172_)</b>			<b>11/2007 →</b>		
Alternator Freewheel Clutch	1.3 JTD		<b>F5-1045</b>		
Belt Pulley, crankshaft	1.3 JTD	Number of grooves: 4, 6; Number of Ribs: 3, 5; Parameter: 4PK+6PK	<b>F8-7647</b>		d=35.03; Mounting points diam.[mm]=8.5; D1=164.9; D2=145
<b>SIENA (178_)</b>			<b>04/1996 → 12/2009</b>		
Dust Cover Kit, shock absorber	1.0, 1.2, 1.3 JTD, 1.4, 1.4 CAT, 1.5, 1.6, 1.6 16V, 1.7 TD, 1.9 D		<b>AK-735443</b>		
Alternator Freewheel Clutch	1.3 JTD, 1.7 TD		<b>F5-1045</b>		
Alternator Freewheel Clutch	1.9 D		<b>F5-1123</b>		
Control Arm-/Trailing Arm Bush	1.0, 1.2, 1.4, 1.4 CAT, 1.6 16V		<b>F8-5273</b>		
Top Strut Mounting	1.0, 1.2, 1.4, 1.4 CAT, 1.6 16V		<b>F8-6367</b>		
Top Strut Mounting	1.0, 1.2, 1.4, 1.4 CAT, 1.6 16V		<b>F8-7158</b>		
Belt Pulley, crankshaft	1.3 JTD	Number of grooves: 4, 6; Number of Ribs: 3, 5; Parameter: 4PK+6PK	<b>F8-7647</b>		d=35.03; Mounting points diam.[mm]=8.5; D1=164.9; D2=145
Repair Set, axle beam	1.0, 1.2, 1.4, 1.4 CAT, 1.6, 1.6 16V, 1.9 D		<b>G8-555</b>		
<b>STILO (192)</b>			<b>10/2001 → 11/2006</b>		
Dust Cover Kit, shock absorber	1.2 16V , 1.4 16V, 1.6 16V , 1.8 16V , 1.9 JTD, 2.4 20V		<b>AK-735067</b>		
Alternator Freewheel Clutch	1.9 D Multijet, 1.9 JTD		<b>F5-1098</b>		
Alternator Freewheel Clutch	1.9 D Multijet, 1.9 JTD		<b>F5-1123</b>		
Control Arm-/Trailing Arm Bush	1.2 16V , 1.6 16V , 1.8 16V , 1.9 JTD , 2.4 20V		<b>F8-5264</b>		
Control Arm-/Trailing Arm Bush	1.2 16V , 1.6 16V , 1.8 16V , 1.9 JTD , 2.4 20V		<b>F8-5265</b>		
Anti-Friction Bearing	1.2 16V , 1.4 16V, 1.6 16V , 1.8 16V , 1.9 D Multijet, 1.9 JTD, 2.4 20V		<b>F8-6264</b>		H=9; D=110
Top Strut Mounting	1.2 16V , 1.4 16V, 1.6 16V , 1.8 16V , 1.9 D Multijet, 1.9 JTD, 2.4 20V		<b>F8-6290</b>		
Belt Pulley, crankshaft	1.9 JTD	Number of Ribs: 5; Parameter: 6PK; with screw set	<b>F8-6393</b>		D=169
Spring Cap	1.2 16V , 1.4 16V, 1.6, 1.6 16V , 1.8 16V , 1.9 D Multijet, 1.9 JTD, 2.4 20V		<b>F8-6521</b>		

<b>AK-735067</b>	<b>AK-735443</b>	<b>F5-1045</b>	<b>F5-1098</b>	<b>F5-1123</b>	<b>F8-5264</b>	<b>F8-5265</b>
Ref.Nr.:	Ref.Nr.: 46464298	Ref.Nr.: 77362721	Ref.Nr.: 77364725	Ref.Nr.: 9948513	Ref.Nr.: 50700443	Ref.Nr.: 50700778
<b>F8-5273</b>	<b>F8-5598</b>	<b>F8-6264</b>	<b>F8-6290</b>	<b>F8-6367</b>	<b>F8-6393</b>	<b>F8-6521</b>
Ref.Nr.: 46421522	Ref.Nr.: 7667087	Ref.Nr.: 50700871	Ref.Nr.: 50702841	Ref.Nr.: 46760673	Ref.Nr.: 55196301	Ref.Nr.: 46786245
<b>F8-6735</b>	<b>F8-6896</b>	<b>F8-7158</b>	<b>F8-7647</b>	<b>G8-555</b>	<b>G9-534</b>	
Ref.Nr.: 50700871	Ref.Nr.: 46749600	Ref.Nr.: 46760674	Ref.Nr.: 55182506	Ref.Nr.:	Ref.Nr.: 5927293	

Article Description

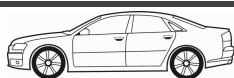

Article Nr.

Fitting Position



<b>STILO (192)</b>		<b>10/2001 → 11/2006</b>	
Supporting Ring, suspension strut bearing	1.2 16V , 1.4 16V, 1.6 16V , 1.8 16V , 1.9 D Multijet, 1.9 JTD, 2.4 20V		<b>F8-6735</b>
Protective Cap/Bellow, shock absorber	All Models		<b>F8-7592</b>
Bellow Set, drive shaft	1.9 JTD , 2.4 20V	with clamps	<b>MK-810160</b>
<b>STILO Multi Wagon (192)</b>		<b>01/2003 → 08/2008</b>	
Alternator Freewheel Clutch	1.9 D, 1.9 D Multijet, 1.9 JTD		<b>F5-1098</b>
Alternator Freewheel Clutch	1.9 D, 1.9 D Multijet, 1.9 JTD		<b>F5-1123</b>
Anti-Friction Bearing	1.4 16V, 1.6 16V, 1.8 16V, 1.9 D Multijet, 1.9 JTD		<b>F8-6264</b>
Top Strut Mounting	1.4 16V, 1.6 16V, 1.8 16V, 1.9 D Multijet, 1.9 JTD		<b>F8-6290</b>
Belt Pulley, crankshaft	1.9 JTD	Number of Ribs: 5; Parameter: 6PK; with screw set	<b>F8-6393</b>
Spring Cap	1.4 16V, 1.6 16V, 1.8 16V, 1.9 D, 1.9 D Multijet, 1.9 JTD		<b>F8-6521</b>
Supporting Ring, suspension strut bearing	1.4 16V, 1.6 16V, 1.8 16V, 1.9 D Multijet, 1.9 JTD		<b>F8-6735</b>
Protective Cap/Bellow, shock absorber	1.4 16V, 1.6 16V, 1.8 16V, 1.9 D, 1.9 D Multijet, 1.9 JTD		<b>F8-7592</b>
Bellow Set, drive shaft	1.9 JTD	with clamps	<b>MK-810160</b>
<b>STRADA Pickup (178E)</b>		<b>06/1999 →</b>	
Dust Cover Kit, shock absorber	All Models		<b>AK-735353</b>
Alternator Freewheel Clutch	1.9 JTD		<b>F5-1005</b>
Alternator Freewheel Clutch	1.3 D Multijet		<b>F5-1045</b>
Alternator Freewheel Clutch	1.9 D, 1.9 JTD		<b>F5-1123</b>
Control Arm-Trailing Arm Bush	1.2, 1.7 TD		<b>F8-5273</b>
Top Strut Mounting	1.2, 1.7 TD, 1.9 D, 1.9 JTD		<b>F8-6367</b>
Belt Pulley, crankshaft	1.9 D, 1.9 JTD	Number of Ribs: 5; Parameter: 6PK; with screw set	<b>F8-6393</b>
Bush, leaf spring	All Models		<b>F8-6602</b>
Bearing Bush, stabiliser	1.2, 1.7 TD, 1.9 D		<b>F8-6731</b>
Top Strut Mounting	1.2, 1.7 TD, 1.9 D, 1.9 JTD		<b>F8-7158</b>
Belt Pulley, crankshaft	1.3 D Multijet	Number of grooves: 4, 6; Number of Ribs: 3, 5; Parameter: 4PK+6PK	<b>F8-7647</b>
Belt Pulley, crankshaft	1.2	Engine →1715697;	<b>F8-7648</b>
<b>STRADA Pickup (578_, 278_)</b>		<b>10/2010 →</b>	
Alternator Freewheel Clutch	All Models		<b>F5-1045</b>

<b>AK-735070</b>	<b>AK-735353</b>	<b>F5-1005</b>	<b>F5-1045</b>	<b>F5-1098</b>	<b>F5-1123</b>	<b>F8-5273</b>
Ref.Nr.:	Ref.Nr.: 46466619	Ref.Nr.: 9951162	Ref.Nr.: 77362721	Ref.Nr.: 77364725	Ref.Nr.: 9948513	Ref.Nr.: 46421522
<b>F8-6264</b>	<b>F8-6290</b>	<b>F8-6367</b>	<b>F8-6393</b>	<b>F8-6521</b>	<b>F8-6602</b>	<b>F8-6731</b>
Ref.Nr.: 50700871	Ref.Nr.: 50702841	Ref.Nr.: 46760673	Ref.Nr.: 55196301	Ref.Nr.: 46786245	Ref.Nr.: 7743792	Ref.Nr.: 7750990
<b>F8-6735</b>	<b>F8-7158</b>	<b>F8-7592</b>	<b>F8-7647</b>	<b>F8-7648</b>	<b>MK-810160</b>	
Ref.Nr.: 50700871	Ref.Nr.: 46760674	Ref.Nr.: 50701328	Ref.Nr.: 55182506	Ref.Nr.: 7778028	Ref.Nr.: 3D0 498 201	



**Article Description****Article Nr.****Fitting Position**

<b>TALENTO Bus (290)</b>		<b>03/1989 → 03/1994</b>	
Dust Cover Kit, shock absorber	All Models	AK-735070	
Tie Bar Bush	All Models	F8-5084	⊕ ⊕ H=24.5; H1=20.5; d=22; D=48
Top Strut Mounting	All Models	F8-5612	⊕ ⊕
Mounting, leaf spring	All Models	F8-5870	⊕ ⊕ H=72; d=16; D=38
Engine Mounting	All Models	F8-6496	
Engine Mounting	All Models	F8-6509	
Engine Mounting	All Models	F8-6903	⊕
<b>TALENTO Box (290)</b>		<b>03/1989 → 03/1994</b>	
Dust Cover Kit, shock absorber	All Models	AK-735070	
Tie Bar Bush	All Models	F8-5084	⊕ ⊕ H=24.5; H1=20.5; d=22; D=48
Top Strut Mounting	All Models	F8-5612	⊕ ⊕
Mounting, leaf spring	All Models	F8-5870	⊕ ⊕ H=72; d=16; D=38
Engine Mounting	All Models	F8-6496	
Engine Mounting	All Models	F8-6509	
Engine Mounting	All Models	F8-6903	⊕
<b>TALENTO Platform/Chassis (290)</b>		<b>03/1989 → 03/1994</b>	
Dust Cover Kit, shock absorber	All Models	AK-735070	
Tie Bar Bush	All Models	F8-5084	⊕ ⊕ H=24.5; H1=20.5; d=22; D=48
Top Strut Mounting	All Models	F8-5612	⊕ ⊕
Mounting, leaf spring	All Models	F8-5870	⊕ ⊕ H=72; d=16; D=38
Engine Mounting	All Models	F8-6496	
Engine Mounting	All Models	F8-6509	
Engine Mounting	All Models	F8-6903	⊕
<b>TEMPRA (159)</b>		<b>03/1990 → 08/1996</b>	
Dust Cover Kit, shock absorber	1.4 i.e., 1.6, 1.6 i.e., 1.8 i.e., 1.9 D, 1.9 TD, 2.0 i.e.	AK-735018	⊕ ⊕
Dust Cover Kit, shock absorber	1.4 i.e., 1.6, 1.6 i.e., 1.8 i.e., 1.9 D, 1.9 TD, 2.0 i.e.	AK-735337	⊕ ⊕
Anti-Friction Bearing	1.4 i.e., 1.6, 1.6 i.e.	F8-3015	⊕ ⊕ H=48; d1=79; d2=84; D1=116; D2=128
Anti-Friction Bearing	1.9 TD	F8-3015	⊕ ⊕ H=48; d1=79; d2=84; D1=116; D2=128
Stabiliser Mounting	1.4 i.e., 1.6, 1.6 i.e., 1.8 i.e., 1.9 TD, 2.0 i.e.	F8-5094	d=22
Top Strut Mounting	1.4 i.e., 1.6, 1.6 i.e., 1.8 i.e., 1.9 D, 1.9 TD, 2.0 i.e.	F8-5513	⊕
Top Strut Mounting	1.4 i.e., 1.6, 1.6 i.e., 1.8 i.e., 1.9 D, 1.9 TD, 2.0 i.e.	F8-5514	⊕
Engine Mounting	1.4 i.e., 1.6, 1.6 i.e.	F8-5641	⊕
Spring Cap	1.4 i.e., 1.6, 1.6 i.e., 1.8 i.e., 1.9 D, 1.9 TD, 2.0 i.e.	F8-5956	⊕ ⊕

<b>AK-735018</b>	<b>AK-735070</b>	<b>AK-735337</b>	<b>F8-3015</b>	<b>F8-5084</b>	<b>F8-5094</b>	<b>F8-5513</b>
Ref.Nr.:	Ref.Nr.:	Ref.Nr.: 7599485	Ref.Nr.: 7601502	Ref.Nr.: 3561.08	Ref.Nr.: 07760424	Ref.Nr.: 46414184
<b>F8-5514</b>	<b>F8-5612</b>	<b>F8-5641</b>	<b>F8-5870</b>	<b>F8-5956</b>	<b>F8-6496</b>	<b>F8-6509</b>
Ref.Nr.: 46414184	Ref.Nr.: 04466980	Ref.Nr.: 7610157	Ref.Nr.: 04333710	Ref.Nr.: 7602150	Ref.Nr.: 1844.41	Ref.Nr.: 1843.61
<b>F8-6885</b>	<b>F8-6903</b>					
Ref.Nr.: 7610541	Ref.Nr.: 5934176					

Article Description



Article Nr.

Fitting Position



<b>TEMPRA (159)</b>			<b>03/1990 → 08/1996</b>		
Engine Mounting	1.4 i.e. , 1.6, 1.6 i.e.		<b>F8-6885</b>	⊕	
Engine Mounting	1.4 i.e. , 1.6, 1.6 i.e.		<b>F8-6886</b>		
Engine Mounting	1.6 i.e.	159 A3.048, 835 C1.000; Type: 159.AS	<b>F8-6886</b>		
Engine Mounting	1.8 i.e.		<b>F8-6914</b>		
Belt Pulley, crankshaft	1.9 D , 1.9 TD	07/1993 →;	<b>F8-7863</b>		
Control Arm-/Trailing Arm Bush	1.4 i.e. , 1.6, 1.6 i.e. , 1.8 i.e. , 1.9 TD , 2.0 i.e.		<b>G9-530</b>	⊕ ⊕	H=50; d=20; D=41
Control Arm-/Trailing Arm Bush	1.4 i.e. , 1.6, 1.6 i.e. , 1.8 i.e. , 1.9 TD , 2.0 i.e.		<b>G9-531</b>	⊕	H=52; d=20; D=59
Control Arm-/Trailing Arm Bush	1.4 i.e. , 1.6, 1.6 i.e. , 1.8 i.e. , 1.9 TD , 2.0 i.e.		<b>G9-532</b>	⊕	H=53; d=20; D=58
<b>TEMPRA S.W. (159)</b>			<b>03/1990 → 08/1996</b>		
Dust Cover Kit, shock absorber	1.4 i.e. , 1.6 i.e. , 1.8 i.e. , 1.9 TD , 2.0 i.e. , 2.0 i.e. 4x4		<b>AK-735018</b>	⊕ ⊕ ⊕	
Stabiliser Mounting	1.4 i.e. , 1.6 i.e. , 1.8 i.e. , 1.9 TD , 2.0 i.e.		<b>F8-5094</b>		d=22
Top Strut Mounting	1.4 i.e. , 1.6 i.e. , 1.8 i.e. , 1.9 D , 1.9 TD , 2.0 i.e. , 2.0 i.e. 4x4		<b>F8-5513</b>	⊕	
Top Strut Mounting	1.4 i.e. , 1.6 i.e. , 1.8 i.e. , 1.9 D , 1.9 TD , 2.0 i.e. , 2.0 i.e. 4x4		<b>F8-5514</b>	⊕	
Engine Mounting	1.4 i.e. , 1.6, 1.6 i.e.		<b>F8-5641</b>	⊕	
Spring Cap	All Models		<b>F8-5956</b>	⊕ ⊕ ⊕	
Engine Mounting	1.4 i.e. , 1.6, 1.6 i.e.		<b>F8-6885</b>	⊕	
Engine Mounting	1.4 i.e. , 1.6, 1.6 i.e.		<b>F8-6886</b>		
Engine Mounting	1.6 i.e.	159 A3.048, 835 C1.000; Type: 159.AS	<b>F8-6886</b>		
Engine Mounting	1.8 i.e.		<b>F8-6914</b>		
Belt Pulley, crankshaft	1.9 TD	07/1993 →;	<b>F8-7863</b>		
Control Arm-/Trailing Arm Bush	1.4 i.e. , 1.6, 1.6 i.e. , 1.8 i.e. , 1.9 TD , 2.0 i.e. , 2.0 i.e. 4x4		<b>G9-530</b>	⊕ ⊕	H=50; d=20; D=41
Control Arm-/Trailing Arm Bush	1.4 i.e. , 1.6, 1.6 i.e. , 1.8 i.e. , 1.9 TD , 2.0 i.e. , 2.0 i.e. 4x4		<b>G9-531</b>	⊕	H=52; d=20; D=59
Control Arm-/Trailing Arm Bush	1.4 i.e. , 1.6, 1.6 i.e. , 1.8 i.e. , 1.9 TD , 2.0 i.e. , 2.0 i.e. 4x4		<b>G9-532</b>	⊕	H=53; d=20; D=58
<b>TIPO (160)</b>			<b>07/1987 → 10/1995</b>		
Dust Cover Kit, shock absorber	1.1 , 1.4 , 1.4 i.e. , 1.6 , 1.6 i.e. , 1.7 D , 1.8 i.e. , 1.9 TD , 2.0 16V , 2.0 i.e. , 2.0 i.e. 16V Sport		<b>AK-735018</b>	⊕ ⊕ ⊕	
Dust Cover Kit, shock absorber	1.1 , 1.4 , 1.4 i.e. , 1.6 , 1.6 i.e. , 1.6 SX DGT , 1.7 D , 1.8 i.e. , 1.8 i.e. 16V Sport , 1.9 D , 1.9 TD , 2.0 16V , 2.0 i.e. , 2.0 i.e. 16V Sport		<b>AK-735337</b>	⊕ ⊕ ⊕	
Anti-Friction Bearing	1.1 , 1.4 , 1.4 i.e. , 1.6 , 1.6 i.e. , 1.7 D , 1.9 TD		<b>F8-3015</b>	⊕ ⊕ ⊕	H=48; d1=79; d2=84; D1=116; D2=128



**Article Description****Article Nr.****Fitting Position**

<b>TIPO (160)</b>		<b>07/1987 → 10/1995</b>	
Anti-Friction Bearing	1.8 i.e., 2.0 16V, 2.0 i.e., 2.0 i.e. 16V Sport		<b>F8-3015</b>
Stabiliser Mounting	1.1, 1.4, 1.4 i.e., 1.6, 1.6 i.e., 1.7 D, 1.8 i.e., 1.9 TD, 2.0 16V, 2.0 i.e., 2.0 i.e. 16V Sport		<b>F8-5094</b>
Top Strut Mounting	1.1, 1.4, 1.4 i.e., 1.6, 1.6 i.e., 1.7 D, 1.8 i.e., 1.8 i.e., 1.9 D, 1.9 TD, 2.0 16V, 2.0 i.e., 2.0 i.e. 16V Sport		<b>F8-5513</b>
Top Strut Mounting	1.1, 1.4, 1.4 i.e., 1.6, 1.6 i.e., 1.7 D, 1.8 i.e., 1.8 i.e., 1.9 D, 1.9 TD, 2.0 16V, 2.0 i.e., 2.0 i.e. 16V Sport		<b>F8-5514</b>
Engine Mounting	1.1, 1.4, 1.4 i.e., 1.6, 1.6 i.e., 1.7 D, 1.9 D		<b>F8-5641</b>
Spring Cap	1.1, 1.4, 1.4 i.e., 1.6, 1.6 i.e., 1.6 SX DGT, 1.7 D, 1.8 i.e., 1.8 i.e., 1.8 i.e. 16V Sport, 1.9 D, 1.9 TD, 2.0, 2.0 16V, 2.0 i.e., 2.0 i.e. 16V Sport		<b>F8-5956</b>
Engine Mounting	1.4, 1.4 i.e., 1.6, 1.6 i.e.		<b>F8-6885</b>
Engine Mounting	1.1		<b>F8-6886</b>
Engine Mounting	1.4, 1.4 i.e., 1.6, 1.6 i.e.		<b>F8-6886</b>
Engine Mounting	1.6 i.e.	159 A3.048, 835 C1.000;	<b>F8-6886</b>
Engine Mounting	1.1		<b>F8-6895</b>
Engine Mounting	1.8 i.e.		<b>F8-6914</b>
Belt Pulley, crankshaft	1.9 D, 1.9 TD		<b>F8-7863</b>
Control Arm-/Trailing Arm Bush	1.1, 1.4, 1.4 i.e., 1.6, 1.6 i.e., 1.7 D, 1.8 i.e., 1.9 TD, 2.0 16V, 2.0 i.e., 2.0 i.e. 16V Sport		<b>G9-530</b>
Control Arm-/Trailing Arm Bush	1.1, 1.4, 1.4 i.e., 1.6, 1.6 i.e., 1.7 D, 1.8 i.e., 1.9 TD, 2.0 16V, 2.0 i.e., 2.0 i.e. 16V Sport		<b>G9-531</b>
Control Arm-/Trailing Arm Bush	1.1, 1.4, 1.4 i.e., 1.6, 1.6 i.e., 1.7 D, 1.8 i.e., 1.9 TD, 2.0 16V, 2.0 i.e., 2.0 i.e. 16V Sport		<b>G9-532</b>
<b>ULYSSE (179AX)</b>		<b>08/2002 → 06/2011</b>	
Dust Cover Kit, shock absorber	2.0, 2.0 D Multijet, 2.0 JTD, 2.2 JTD, 3.0 V6		<b>AK-735351</b>
Alternator Freewheel Clutch	2.0 D Multijet, 2.0 JTD, 2.2 D Multijet, 2.2 JTD		<b>F5-1020</b>
Alternator Freewheel Clutch	2.0 D Multijet, 2.0 JTD, 2.2 D Multijet, 2.2 JTD		<b>F5-1046</b>
Alternator Freewheel Clutch	2.2 JTD		<b>F5-1048</b>
Anti-Friction Bearing	All Models		<b>F8-3014</b>
Engine Mounting	2.0, 2.0 JTD		<b>F8-5569</b>
Top Strut Mounting	2.0, 2.0 JTD, 3.0 V6		<b>F8-5621</b>
Top Strut Mounting	2.0, 2.0 JTD, 3.0 V6		<b>F8-5622</b>
Belt Pulley, crankshaft	2.0 JTD, 2.2 JTD		<b>F8-5636</b>
Belt Pulley, crankshaft	2.0 D Multijet, 2.0 JTD	Orga.10148→	<b>F8-5660</b>
Belt Pulley, crankshaft	2.0 JTD		<b>F8-5660</b>
Belt Pulley, crankshaft	2.2 JTD	Orga.10248→	<b>F8-5660</b>

<b>AK-735351</b>	<b>F5-1020</b>	<b>F5-1046</b>	<b>F5-1048</b>	<b>F8-3014</b>	<b>F8-3015</b>	<b>F8-5094</b>
Ref.Nr.: 1311716080	Ref.Nr.: 31771-68D01	Ref.Nr.: 30667687	Ref.Nr.: 77363468	Ref.Nr.: 503545	Ref.Nr.: 7601502	Ref.Nr.: 07760424
<b>F8-5513</b>	<b>F8-5514</b>	<b>F8-5569</b>	<b>F8-5621</b>	<b>F8-5622</b>	<b>F8-5636</b>	<b>F8-5641</b>
Ref.Nr.: 46414184	Ref.Nr.: 46414184	Ref.Nr.: 9604338880	Ref.Nr.: 1311931080	Ref.Nr.: 503868	Ref.Nr.: 0515P2	Ref.Nr.: 7610157
<b>F8-5660</b>	<b>F8-5871</b>	<b>F8-5956</b>	<b>F8-6885</b>	<b>F8-6886</b>	<b>F8-6895</b>	<b>F8-6914</b>
Ref.Nr.: 0515R9	Ref.Nr.: 515261	Ref.Nr.: 7602150	Ref.Nr.: 7610541	Ref.Nr.: 7629021	Ref.Nr.: 7594993	Ref.Nr.: 60805971

Article Description



Article Nr.

Fitting Position



<b>ULYSSE (179AX)</b>		<b>08/2002 → 06/2011</b>	
Mounting, axle beam	2.0, 2.0 JTD, 3.0 V6	<b>F8-5871</b>	
Engine Mounting	2.0, 2.0 JTD, 2.2 JTD, 3.0 V6	<b>F8-6236</b>	
Top Strut Mounting	2.0, 2.0 JTD, 2.2 JTD, 3.0 V6	<b>F8-6304</b>	
Control Arm-/Trailing Arm Bush	2.0, 2.0 JTD, 2.2 JTD, 3.0 V6	<b>F8-6439</b>	
Engine Mounting	2.0 JTD, 2.2 JTD	<b>F8-6507</b>	
Engine Mounting	2.0, 2.0 JTD	<b>F8-6507</b>	
Top Strut Mounting	2.0, 2.0 JTD, 2.2 JTD, 3.0 V6	<b>F8-7164</b>	
Belt Pulley, crankshaft	2.0 D Multijet	<b>F8-7861</b>	
Engine Mounting	2.0 D Multijet, 2.0 JTD, 2.2 D Multijet, 2.2 JTD	<b>F8-8149</b>	
Engine Mounting	2.0 JTD, 2.2 JTD	<b>F8-8167</b>	
<b>ULYSSE (220)</b>		<b>06/1994 → 08/2002</b>	
Dust Cover Kit, shock absorber	1.8, 1.9 TD, 2.0, 2.0 16V, 2.0 JTD, 2.0 Turbo, 2.1 TD	<b>AK-735091</b>	
Alternator Freewheel Clutch	2.0 JTD, 2.0 JTD 16V	<b>F5-1020</b>	
Alternator Freewheel Clutch	2.0 JTD, 2.0 JTD 16V	<b>F5-1046</b>	
Anti-Friction Bearing	1.8, 1.9 TD, 2.0, 2.0 16V, 2.0 JTD, 2.0 JTD 16V, 2.0 Turbo, 2.1 TD	<b>F8-3014</b>	H1=24; H2=46; d1=78; d2=84; D=128
Engine Mounting	1.9 TD, 2.1 TD	<b>F8-5026</b>	d=10; D=70; Thick. [mm]=40, 53
Stabiliser Mounting	1.8, 1.9 TD, 2.1 TD	<b>F8-5092</b>	d=24
Stabiliser Mounting	2.0, 2.0 Turbo	<b>F8-5092</b>	d=24
Engine Mounting	1.8, 2.0	<b>F8-5569</b>	
Top Strut Mounting	1.8, 1.9 TD, 2.0, 2.0 16V, 2.0 JTD, 2.0 Turbo, 2.1 TD	<b>F8-5621</b>	
Top Strut Mounting	1.8, 1.9 TD, 2.0, 2.0 16V, 2.0 JTD, 2.0 Turbo, 2.1 TD	<b>F8-5622</b>	
Belt Pulley, crankshaft	2.0 JTD	<b>F8-5636</b>	d=30
Belt Pulley, crankshaft	1.9 TD	<b>F8-5643</b>	Belt Pulley Ø [mm]=156; W=44
Mounting, axle beam	1.8, 1.9 TD, 2.0, 2.0 16V, 2.0 JTD, 2.0 Turbo, 2.1 TD	<b>F8-5871</b>	H1=60; H2=48; d=12; D=46
Rubber Buffer, suspension	1.8, 1.9 TD, 2.0, 2.0 16V, 2.0 JTD, 2.0 Turbo, 2.1 TD	<b>F8-5936</b>	
Control Arm-/Trailing Arm Bush	1.8, 1.9 TD, 2.0, 2.0 16V, 2.0 JTD, 2.0 Turbo, 2.1 TD	<b>F8-6153</b>	
Control Arm-/Trailing Arm Bush	1.8, 1.9 TD, 2.0, 2.0 16V, 2.0 JTD, 2.0 Turbo, 2.1 TD	<b>F8-6154</b>	
Control Arm-/Trailing Arm Bush	1.8, 1.9 TD, 2.0, 2.0 16V, 2.0 JTD, 2.0 Turbo, 2.1 TD	<b>F8-6155</b>	
Engine Mounting	1.8, 1.9 TD, 2.0, 2.0 16V, 2.0 JTD, 2.0 Turbo, 2.1 TD	<b>F8-6236</b>	H1=53; H2=40; d=10; D=70
Top Strut Mounting	1.8, 1.9 TD, 2.0, 2.0 16V, 2.0 JTD, 2.0 Turbo, 2.1 TD	<b>F8-6304</b>	

<b>AK-735091</b>	<b>F5-1020</b>	<b>F5-1046</b>	<b>F8-3014</b>	<b>F8-5026</b>	<b>F8-5092</b>	<b>F8-5569</b>
Ref.Nr.: 503339	Ref.Nr.: 31771-68D01	Ref.Nr.: 30667687	Ref.Nr.: 503545	Ref.Nr.: 9606121080	Ref.Nr.: 1305782080	Ref.Nr.: 9604338880
<b>F8-5621</b>	<b>F8-5622</b>	<b>F8-5636</b>	<b>F8-5643</b>	<b>F8-5871</b>	<b>F8-5936</b>	<b>F8-6153</b>
Ref.Nr.: 1311931080	Ref.Nr.: 503868	Ref.Nr.: 0515P2	Ref.Nr.: 96089 38980	Ref.Nr.: 515261	Ref.Nr.: 5033.39	Ref.Nr.: 3520.G9S1
<b>F8-6154</b>	<b>F8-6155</b>	<b>F8-6236</b>	<b>F8-6304</b>	<b>F8-6439</b>	<b>F8-6507</b>	<b>F8-7164</b>
Ref.Nr.: 3521.C9S	Ref.Nr.: 1316735080S	Ref.Nr.: 1809.21	Ref.Nr.: 1311930080	Ref.Nr.: 1312317080	Ref.Nr.: 1827.16	Ref.Nr.: 503555

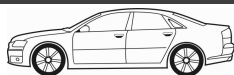
**Article Description****Article Nr.****Fitting Position**

<b>ULYSSE (220)</b>		<b>06/1994 → 08/2002</b>	
Control Arm-/Trailing Arm Bush	1.8, 1.9 TD, 2.0, 2.0 Turbo, 2.1 TD		F8-6439  ⊕ ⊕
Engine Mounting	1.9 TD, 2.0 16V, 2.0 JTD, 2.1 TD		F8-6507 ⊕
Engine Mounting	2.0 16V	05/2000 →;	F8-6507 ⊕
Engine Mounting	2.0 Turbo	05/1996 →;	F8-6507 ⊕
Top Strut Mounting	1.8, 1.9 TD, 2.0, 2.0 16V, 2.0 JTD, 2.0 Turbo, 2.1 TD		F8-7164  ⊕
Engine Mounting	2.0 JTD, 2.0 JTD 16V		F8-8149 ⊕
Engine Mounting	2.0 JTD		F8-8167 ⊕
Bellow, steering	1.8, 1.9 TD, 2.0, 2.0 16V, 2.0 JTD, 2.0 Turbo, 2.1 TD	with clamps	LM-10022S  ⊕ ⊕ ⊕ d1=13; d2=62; L [mm]=210
<b>UNO (146A/E)</b>		<b>01/1983 → 06/2001</b>	
Dust Cover Kit, shock absorber	1.3 Super Diesel, 1.3 Turbo i.e., 1.4 Turbo i.e., 45 0.9, 45 1.0, 45 i.e. 1.0, 50 1.1, 50 i.e. 1.1, 55 1.1, 60 1.1, 60 Diesel 1.7, 70 1.3, 70 i.e. 1.4, 70 TD 1.4, 75 i.e. 1.5		AK-735005  ⊕ ⊕ ⊕
Dust Cover Kit, shock absorber	1.3 Super Diesel, 1.3 Turbo i.e., 1.4 Turbo i.e., 1.6, 1.6 R, 1.9 D, 45 0.9, 45 1.0, 45 i.e. 1.0, 50 1.1, 50 i.e. 1.1, 55 1.0, 55 1.1, 60 1.1, 60 Diesel 1.7, 70 1.3, 70 i.e. 1.4, 70 S 1.4, 70 TD 1.4, 75 i.e. 1.5		AK-735097
Anti-Friction Bearing	1.0, 1.3 Super Diesel, 1.3 Turbo i.e., 1.4, 1.4 Turbo, 1.4 Turbo i.e., 1.6, 1.6 R, 1.9 D, 45 0.9, 45 1.0, 45 i.e. 1.0, 50 1.1, 50 i.e. 1.1, 55 1.1, 60 1.1, 60 Diesel 1.7, 70 1.3, 70 i.e. 1.4, 70 S 1.4, 70 TD 1.4, 75 i.e. 1.5		F8-3017  ⊕ ⊕ ⊕ d=50; D=70
Stabiliser Mounting	1.3 Super Diesel, 1.3 Turbo i.e., 1.4 Turbo i.e., 45 1.0, 45 i.e. 1.0, 50 1.1, 50 i.e. 1.1, 60 1.1, 60 Diesel 1.7, 70 i.e. 1.4, 70 TD 1.4, 75 i.e. 1.5		F8-5083  d=18
Top Strut Mounting	1.0, 1.3 Super Diesel, 1.3 Turbo i.e., 1.4, 1.4 Turbo, 1.4 Turbo i.e., 1.6, 1.6 R, 1.9 D, 45 0.9, 45 1.0, 45 i.e. 1.0, 50 1.1, 50 i.e. 1.1, 55 1.0, 55 1.1, 60 1.1, 60 Diesel 1.7, 70 1.3, 70 i.e. 1.4, 70 S 1.4, 70 TD 1.4, 75 i.e. 1.5		F8-5515  ⊕ ⊕ ⊕
Top Strut Mounting	1.3 Super Diesel, 1.3 Turbo i.e., 1.6 R, 1.9 D, 45 0.9, 45 1.0, 45 i.e. 1.0, 50 1.1, 55 1.1, 60 1.1, 60 Diesel 1.7, 70 1.3, 70 i.e. 1.4, 70 S 1.4, 70 TD 1.4, 75 i.e. 1.5		F8-5563  ⊕ ⊕ ⊕
Stabiliser Mounting	1.0, 1.3 Super Diesel, 1.3 Turbo i.e., 1.4, 1.4 Turbo i.e., 1.9 D, 45 1.0, 45 i.e. 1.0, 50 1.1, 50 i.e. 1.1, 60 1.1, 60 Diesel 1.7, 70 i.e. 1.4, 70 S 1.4, 70 TD 1.4, 75 i.e. 1.5		F8-5642  ⊕ ⊕ ⊕ d=18
Stabiliser Mounting	1.3 Turbo i.e., 45 1.0, 50 1.1, 70 1.3	01/1989 →	F8-5642  ⊕ ⊕ ⊕ d=18
Stabiliser Mounting	45 0.9	01/1989 →;  146A.000	F8-5642  ⊕ ⊕ ⊕ d=18
Top Strut Mounting	1.0, 1.3 Super Diesel, 1.3 Turbo i.e., 1.4, 1.4 Turbo i.e., 1.9 D, 45 0.9, 45 1.0, 45 i.e. 1.0, 50 1.1, 60 1.1, 60 Diesel 1.7, 70 1.3, 70 i.e. 1.4, 70 S 1.4, 70 TD 1.4, 75 i.e. 1.5		F8-5927  ⊕ ⊕ ⊕

<b>AK-735005</b>	<b>AK-735097</b>	<b>F8-3017</b>	<b>F8-5083</b>	<b>F8-5515</b>	<b>F8-5563</b>	<b>F8-5642</b>
Ref.Nr.:	Ref.Nr.:	Ref.Nr.: 4400895	Ref.Nr.: 7603476	Ref.Nr.: 05968311	Ref.Nr.: 05960254	Ref.Nr.: 7563151
<b>F8-5927</b>	<b>F8-6381</b>	<b>F8-6439</b>	<b>F8-6507</b>	<b>F8-7164</b>	<b>F8-8149</b>	<b>F8-8167</b>
Ref.Nr.: 7537167	Ref.Nr.: 04400895	Ref.Nr.: 1312317080	Ref.Nr.: 1827.16	Ref.Nr.: 503555	Ref.Nr.: 1844.93	Ref.Nr.: 9631575180
<b>LM-10022S</b>						
Ref.Nr.: 4066.41						

Article Description



Article Nr.

Fitting Position



UNO (146A/E)		01/1983 → 06/2001			
Top Strut Mounting	1.3 Super Diesel, 1.3 Turbo i.e., 1.4 Turbo i.e., 1.6, 1.6 R, 1.9 D, 45 0.9, 45 1.0, 45 i.e. 1.0, 50 1.1, 50 i.e. 1.1, 55 1.0, 55 1.1, 60 1.1, 60 Diesel 1.7, 70 1.3, 70 i.e. 1.4, 70 S 1.4, 70 TD 1.4, 75 i.e. 1.5		F8-6381		
Engine Mounting	45 i.e. 1.0	01/1989 →	F8-6887		
Engine Mounting	50 1.1, 50 i.e. 1.1, 60 1.1		F8-6887		
Engine Mounting	45 1.0	01/1989 →;  156 A2.100	F8-6931		
Engine Mounting	45 i.e. 1.0, 60 1.1, 75 i.e. 1.5	01/1989 →	F8-6931		
Engine Mounting	45 1.0	01/1989 →;  156 A2.100	F8-6935		
Engine Mounting	45 i.e. 1.0	01/1989 →	F8-6935		
Engine Mounting	50 1.1, 50 i.e. 1.1, 60 1.1		F8-6935		
Engine Mounting	70 TD 1.4		F8-6937		
Control Arm-/Trailing Arm Bush	1.3 Super Diesel, 1.3 Turbo i.e., 1.4 Turbo i.e., 45 1.0, 45 i.e. 1.0, 50 1.1, 60 1.1, 60 Diesel 1.7, 70 1.3, 70 i.e. 1.4, 70 TD 1.4, 75 i.e. 1.5		G9-508		H1=34; H2=44; d=10; D=29
Stabiliser Mounting	1.3 Super Diesel, 1.3 Turbo i.e., 1.4 Turbo i.e., 45 1.0, 45 i.e. 1.0, 50 1.1, 60 1.1, 60 Diesel 1.7, 70 1.3, 70 i.e. 1.4, 70 TD 1.4, 75 i.e. 1.5		G9-512		H=25; d=14; D=41
Control Arm-/Trailing Arm Bush	1.3 Super Diesel, 1.3 Turbo i.e., 1.4 Turbo i.e., 1.6, 1.6 R, 1.9 D, 45 0.9, 45 1.0, 45 i.e. 1.0, 50 1.1, 50 i.e. 1.1, 55 1.0, 55 1.1, 60 1.1, 60 Diesel 1.7, 70 1.3, 70 i.e. 1.4, 70 S 1.4, 70 TD 1.4, 75 i.e. 1.5		G9-533		H=55; D1=32; D2=38
Control Arm-/Trailing Arm Bush	1.3 Turbo i.e., 1.4 Turbo i.e.	ABS	G9-533		H=55; D1=32; D2=38
Control Arm-/Trailing Arm Bush	1.3 Super Diesel, 1.3 Turbo i.e., 1.4 Turbo i.e., 1.6, 1.6 R, 1.9 D, 45 0.9, 45 1.0, 45 i.e. 1.0, 50 1.1, 50 i.e. 1.1, 55 1.0, 55 1.1, 60 1.1, 60 Diesel 1.7, 70 1.3, 70 i.e. 1.4, 70 S 1.4, 70 TD 1.4, 75 i.e. 1.5		G9-534		H=58; d1=5; d2=22; W=42
<b>X 1/9 (128 AS)</b>		<b>05/1973 → 12/1989</b>			
Control Arm-/Trailing Arm Bush	All Models		G9-506		H=37; d=9,2; D1=25; D2=36

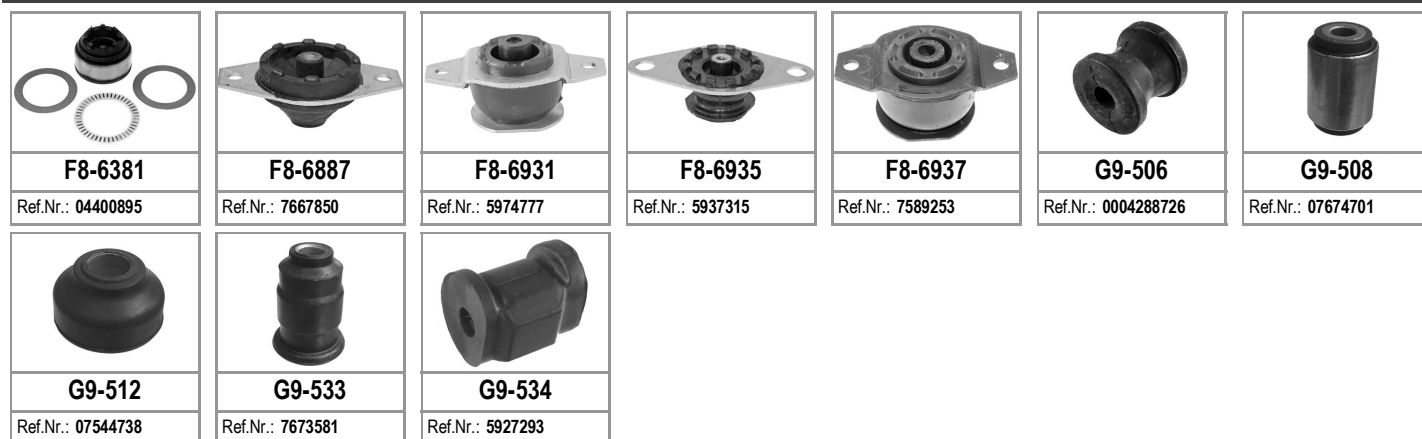

**Article Description****Article Nr.****Fitting Position**

<b>B-MAX (JK)</b>			<b>10/2012 →</b>		
Dust Cover Kit, shock absorber	1.0 EcoBoost, 1.4, 1.5 TDCi, 1.6 TDCi, 1.6 Ti		<b>AK-735095</b>		
Anti-Friction Bearing	1.0 EcoBoost, 1.4, 1.5 TDCi, 1.6 TDCi, 1.6 Ti		<b>F8-7433</b>		
Top Strut Mounting	1.0 EcoBoost, 1.4, 1.5 TDCi, 1.6 TDCi, 1.6 Ti		<b>F8-7434</b>		H=48; d=8
Protective Cap/Bellow, shock absorber	1.0 EcoBoost, 1.4, 1.5 TDCi, 1.6 TDCi, 1.6 Ti		<b>F8-7489</b>		
Rubber Buffer, suspension	1.0 EcoBoost, 1.4, 1.5 TDCi, 1.6 TDCi, 1.6 Ti	<b>ST</b>	<b>F8-7896</b>		
Engine Mounting	1.0 EcoBoost, 1.4, 1.5 TDCi, 1.6 TDCi, 1.6 Ti		<b>F8-8139</b>		
<b>CAPRI (ECJ)</b>			<b>01/1970 → 12/1973</b>		
Bellow, steering	3000	with clamps	<b>LM-10062S</b>		d1=10; d2=46; L [mm]=145
<b>CAPRI Mk II (GECF)</b>			<b>02/1974 → 12/1977</b>		
Bellow, steering	3.0	with clamps	<b>LM-10062S</b>		d1=10; d2=46; L [mm]=145
<b>CAPRI Mk III (GECF)</b>			<b>01/1978 → 12/1981</b>		
Bellow, steering	3.0	with clamps	<b>LM-10062S</b>		d1=10; d2=46; L [mm]=145
<b>C-MAX (DM2)</b>			<b>02/2007 → 09/2010</b>		
Dust Cover Kit, shock absorber	1.6, 1.6 TDCi, 1.8, 1.8 Flexifuel, 1.8 TDCi, 2.0, 2.0 CNG, 2.0 LPG, 2.0 TDCi		<b>AK-735196</b>		
Alternator Freewheel Clutch	1.8 TDCi		<b>F5-1057</b>		
Alternator Freewheel Clutch	2.0, 2.0 CNG, 2.0 LPG	Alternator Charge Current [A]: 120, 150; for OE: 3M5T-10300-VC, 3M5T-10300-VD; Manufacturer Restriction: Denso;	<b>F5-1059</b>		
Mounting, manual transmission	1.8, 1.8 Flexifuel, 2.0		<b>F8-6207</b>		
Top Strut Mounting	1.6, 1.6 TDCi, 1.8, 1.8 Flexifuel, 1.8 TDCi, 2.0, 2.0 CNG, 2.0 LPG, 2.0 TDCi		<b>F8-6210</b>		
Anti-Friction Bearing	1.6, 1.6 TDCi, 1.8, 1.8 Flexifuel, 1.8 TDCi, 2.0, 2.0 CNG, 2.0 LPG, 2.0 TDCi		<b>F8-6268</b>		
Top Strut Mounting	1.6, 1.6 TDCi, 1.8, 1.8 Flexifuel, 1.8 TDCi, 2.0, 2.0 CNG, 2.0 LPG, 2.0 TDCi		<b>F8-6357</b>		
Stabiliser Mounting	1.6, 1.6 TDCi, 1.8, 1.8 Flexifuel, 1.8 TDCi, 2.0, 2.0 CNG, 2.0 LPG, 2.0 TDCi		<b>F8-6637</b>		
Mounting, axle beam	1.6, 1.6 TDCi, 1.8, 1.8 Flexifuel, 1.8 TDCi, 2.0, 2.0 CNG, 2.0 LPG, 2.0 TDCi		<b>F8-6638</b>		D=60
Belt Pulley, crankshaft	1.6 TDCi	Number of Ribs: 6	<b>F8-7082</b>		Belt Pulley Ø [mm]=152; Mounting points diam.[mm]=30; W=34
Top Strut Mounting	1.6, 1.6 TDCi, 1.8, 1.8 Flexifuel, 1.8 TDCi, 2.0, 2.0 TDCi		<b>F8-7156</b>		
Rubber Buffer, suspension	1.6, 1.6 TDCi, 1.8, 1.8 Flexifuel, 1.8 TDCi, 2.0, 2.0 CNG, 2.0 LPG, 2.0 TDCi	<b>ST</b>	<b>F8-7583</b>		H=122.5
Belt Pulley, crankshaft	1.8 TDCi		<b>F8-7649</b>		

<b>AK-735095</b>	<b>AK-735196</b>	<b>F5-1057</b>	<b>F5-1059</b>	<b>F8-6207</b>	<b>F8-6210</b>	<b>F8-6268</b>
Ref.Nr.: 1J0512131B	Ref.Nr.: 1305329	Ref.Nr.: 5M5Q-10344-AA	Ref.Nr.: 3M5T-10300-VC	Ref.Nr.: 1322569	Ref.Nr.: 3M513K155DC	Ref.Nr.: 30639948
<b>F8-6357</b>	<b>F8-6637</b>	<b>F8-6638</b>	<b>F8-7082</b>	<b>F8-7156</b>	<b>F8-7433</b>	<b>F8-7434</b>
Ref.Nr.: 30714395	Ref.Nr.: 1305960	Ref.Nr.: C2Y6-28-460	Ref.Nr.: 0515.R0	Ref.Nr.: BP4L-34-380C	Ref.Nr.: 1514857	Ref.Nr.: 1535299
<b>F8-7489</b>	<b>F8-7583</b>	<b>F8-7649</b>	<b>F8-7838</b>	<b>F8-7896</b>	<b>F8-8139</b>	<b>LM-10062S</b>
Ref.Nr.: 8V51-5349-AB	Ref.Nr.: 1370318	Ref.Nr.: 1131911	Ref.Nr.: 1305329	Ref.Nr.: AY11-3K100-AB	Ref.Nr.: 1695146	Ref.Nr.: 1568676

Article Description

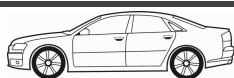

Article Nr.

Fitting Position



<b>C-MAX (DM2)</b>			<b>02/2007 → 09/2010</b>		
Protective Cap/Bellow, shock absorber	1.6, 1.6 TDCi, 1.8, 1.8 Flexifuel, 1.8 TDCi, 2.0, 2.0 CNG, 2.0 LPG, 2.0 TDCi		<b>F8-7838</b>		H=250
Control Arm-/Trailing Arm Bush	1.6, 1.6 TDCi, 1.8, 1.8 TDCi, 2.0, 2.0 CNG, 2.0 LPG, 2.0 TDCi		<b>F8-8078</b>		
Engine Mounting	1.6, 1.6 TDCi, 1.8, 1.8 Flexifuel, 1.8 TDCi, 2.0, 2.0 TDCi		<b>F8-8140</b>		
Engine Mounting	1.6 TDCi		<b>F8-8197</b>		
<b>C-MAX II (DXA/CB7, DXA/CEU)</b>			<b>12/2010 →</b>		
Anti-Friction Bearing	1.0 EcoBoost, 1.6 EcoBoost, 1.6 Flexifuel, 1.6 TDCi, 1.6 Ti, 2.0 TDCi		<b>F8-6268</b>		
Top Strut Mounting	1.0 EcoBoost, 1.6 EcoBoost, 1.6 Flexifuel, 1.6 LPG, 1.6 TDCi, 1.6 Ti, 2.0 TDCi		<b>F8-6357</b>		
Protective Cap/Bellow, shock absorber	1.0 EcoBoost, 1.6 EcoBoost, 1.6 Flexifuel, 1.6 LPG, 1.6 TDCi, 1.6 Ti, 2.0 TDCi		<b>F8-7838</b>		H=250
Control Arm-/Trailing Arm Bush	1.6 EcoBoost, 1.6 Flexifuel, 1.6 Ti, 2.0 TDCi		<b>F8-7853</b>		H=64.7; d=14; D1=54; D2=44.7
Engine Mounting	1.6 EcoBoost, 1.6 Flexifuel, 1.6 LPG, 1.6 TDCi, 1.6 Ti, 2.0 TDCi		<b>F8-8140</b>		
Engine Mounting	2.0 TDCi	Transmission Type: MMT6	<b>F8-8196</b>		
Engine Mounting	1.6 TDCi		<b>F8-8197</b>		
<b>GRAND C-MAX (DXA/CB7, DXA/CEU)</b>			<b>12/2010 →</b>		
Anti-Friction Bearing	1.0 EcoBoost, 1.6 EcoBoost, 1.6 TDCi, 1.6 Ti, 2.0 TDCi		<b>F8-6268</b>		
Top Strut Mounting	1.0 EcoBoost, 1.6 EcoBoost, 1.6 TDCi, 1.6 Ti, 2.0 TDCi		<b>F8-6357</b>		
Protective Cap/Bellow, shock absorber	1.0 EcoBoost, 1.6 EcoBoost, 1.6 TDCi, 1.6 Ti, 2.0 TDCi		<b>F8-7838</b>		H=250
Control Arm-/Trailing Arm Bush	1.6 EcoBoost, 1.6 TDCi, 1.6 Ti, 2.0 TDCi		<b>F8-7853</b>		H=64.7; d=14; D1=54; D2=44.7
Engine Mounting	1.6 EcoBoost, 1.6 TDCi, 1.6 Ti, 2.0 TDCi		<b>F8-8140</b>		
Engine Mounting	2.0 TDCi	Transmission Type: MMT6	<b>F8-8196</b>		
<b>CONSUL (GGFL)</b>			<b>01/1972 → 12/1974</b>		
Bellow, steering	3000	with clamps	<b>LM-10062S</b>		d1=10; d2=46; L [mm]=145
<b>CONSUL Coupe (GGCL)</b>			<b>01/1972 → 12/1974</b>		
Bellow, steering	3000	with clamps	<b>LM-10062S</b>		d1=10; d2=46; L [mm]=145
<b>CONSUL Turnier (GGNL)</b>			<b>01/1972 → 12/1975</b>		
Bellow, steering	3000	with clamps	<b>LM-10062S</b>		d1=10; d2=46; L [mm]=145
<b>COUGAR (EC_)</b>			<b>08/1998 → 12/2001</b>		
Top Strut Mounting	All Models		<b>F8-5503</b>		

<b>F8-5503</b>	<b>F8-5504</b>	<b>F8-6268</b>	<b>F8-6357</b>	<b>F8-7838</b>	<b>F8-7853</b>	<b>F8-8078</b>
Ref.Nr.: 6807407	Ref.Nr.: 6799585	Ref.Nr.: 30639948	Ref.Nr.: 30714395	Ref.Nr.: 1305329	Ref.Nr.: 1749991	Ref.Nr.: 3M5J-3A262-BP
<b>F8-8140</b>	<b>F8-8196</b>	<b>F8-8197</b>	<b>LM-10062S</b>			
Ref.Nr.: 30778647	Ref.Nr.: 1543750	Ref.Nr.: 1345657	Ref.Nr.: 1568676			



**Article Description****Article Nr.****Fitting Position**

<b>COUGAR (EC_)</b>			<b>08/1998 → 12/2001</b>		
Top Strut Mounting	All Models		<b>F8-5504</b>		
Stabiliser Mounting	All Models		<b>F8-6137</b>		d=19
Anti-Friction Bearing	All Models		<b>F8-6262</b>		
Top Strut Mounting	All Models		<b>F8-6308</b>		
Control Arm-/Trailing Arm Bush	All Models		<b>F8-6722</b>		H1=28; H2=35; d=12; D=36,5
Engine Mounting	2.0 16V		<b>F8-7031</b>		
Mounting, axle beam	All Models		<b>F8-7940</b>		H=55; d=12; D1=37,2; D2=38,4
Bellow, steering	All Models	with clamps	<b>LM-10034S</b>		d1=17; d2=58; L [mm]=215
<b>ESCORT '81 Express (AVA)</b>			<b>03/1981 → 02/1986</b>		
Dust Cover Kit, shock absorber	1.1, 1.3, 1.6 D		<b>AK-735005</b>		
Anti-Friction Bearing	1.1, 1.3, 1.6 D		<b>F8-3018</b>		H=11; d1=12; d2=20; D=42.2
Control Arm-/Trailing Arm Bush	1.1, 1.3, 1.6	06/1983 →	<b>F8-5075</b>		H=51; d=10; D=33
Control Arm-/Trailing Arm Bush	1.6 D		<b>F8-5075</b>		H=51; d=10; D=33
Top Strut Mounting	All Models		<b>F8-5507</b>		
Top Strut Mounting	1.1	12/1984 →;	<b>F8-5880</b>		
Engine Mounting	1.6 D		<b>F8-6952</b>		
Control Arm-/Trailing Arm Bush	All Models		<b>G9-500</b>		H=20; d=16; D=46
<b>ESCORT '86 Express (AVF)</b>			<b>02/1986 → 07/1990</b>		
Dust Cover Kit, shock absorber	1.1, 1.3, 1.4 i, 1.6 D, 1.8 D		<b>AK-735005</b>		
Stabiliser Mounting	All Models		<b>F8-5070</b>		d=24
Control Arm-/Trailing Arm Bush	1.1, 1.3, 1.4 i, 1.6, 1.6 D		<b>F8-5075</b>		H=51; d=10; D=33
Control Arm-/Trailing Arm Bush	1.3, 1.8 D	09/1988 →	<b>F8-5075</b>		H=51; d=10; D=33
Stabiliser Mounting	All Models		<b>F8-5080</b>		d=22
Top Strut Mounting	All Models		<b>F8-5507</b>		
Top Strut Mounting	1.1, 1.3, 1.4 i		<b>F8-5880</b>		
Engine Mounting	1.8 D		<b>F8-6492</b>		
Engine Mounting	1.6 D		<b>F8-6952</b>		
Engine Mounting	1.8 D		<b>F8-6953</b>		
Control Arm-/Trailing Arm Bush	All Models		<b>G9-500</b>		H=20; d=16; D=46
Control Arm-/Trailing Arm Bush	1.1, 1.3, 1.8 D	for OE: 1637184, 1637185	<b>G9-522</b>		H=51; d=10; D1=33; D2=38

<b>AK-735005</b>	<b>F8-3018</b>	<b>F8-5070</b>	<b>F8-5075</b>	<b>F8-5080</b>	<b>F8-5504</b>	<b>F8-5507</b>
Ref.Nr.:	Ref.Nr.: 6112404	Ref.Nr.: 1634901	Ref.Nr.: 1619120	Ref.Nr.: 1634900	Ref.Nr.: 6799585	Ref.Nr.: 6119999
<b>F8-5880</b>	<b>F8-6137</b>	<b>F8-6262</b>	<b>F8-6308</b>	<b>F8-6492</b>	<b>F8-6722</b>	<b>F8-6952</b>
Ref.Nr.: 6150276	Ref.Nr.: 1128725	Ref.Nr.: 97BG-3K099-AA	Ref.Nr.: 98BG3K099AA	Ref.Nr.: 1 661 786	Ref.Nr.: 6829045	Ref.Nr.: 6185027
<b>F8-6953</b>	<b>F8-7031</b>	<b>F8-7940</b>	<b>G9-500</b>	<b>G9-522</b>	<b>LM-10034S</b>	
Ref.Nr.: 6178901	Ref.Nr.: 97BB6P082AB	Ref.Nr.: 6829046	Ref.Nr.: 6107025	Ref.Nr.: 1619120	Ref.Nr.: 3904122	

Article Description



Article Nr.

Fitting Position



<b>ESCORT '86 Express (AVF)</b>			<b>02/1986 → 07/1990</b>		
Control Arm-/Trailing Arm Bush	1.4 i, 1.6 D	01/1986 →; for OE: 1637184, 1637185	<b>G9-522</b>		H=51; d=10; D1=33; D2=38
Control Arm-/Trailing Arm Bush	1.6		<b>G9-522</b>		H=51; d=10; D1=33; D2=38
<b>ESCORT '91 Express (AVL)</b>			<b>07/1990 → 12/1994</b>		
Anti-Friction Bearing	All Models		<b>F8-3018</b>		H=11; d1=12; d2=20; D=42.2
Top Strut Mounting	All Models		<b>F8-5522</b>		
Stabiliser Mounting	All Models		<b>F8-6034</b>		d=16
Top Strut Mounting	All Models		<b>F8-6307</b>		
Engine Mounting	1.8 D		<b>F8-6503</b>		
Engine Mounting	1.8 D	Transmission Nr: B5, IB5;	<b>F8-6833</b>		
Engine Mounting	1.8 D		<b>F8-6952</b>		
Mounting, axle beam	All Models		<b>F8-7935</b>		
Control Arm-/Trailing Arm Bush	All Models		<b>G9-585</b>		H1=46; H2=25; d=12; D=46
Control Arm-/Trailing Arm Bush	All Models		<b>G9-586</b>		H1=27; H2=46; d=12; D1=54; D2=62
<b>ESCORT '95 Box (AVL)</b>			<b>01/1995 → 06/2001</b>		
Top Strut Mounting	1.4, 1.8 D, 1.8 Turbo D		<b>F8-5447</b>		
Top Strut Mounting	1.4, 1.8 D, 1.8 Turbo D		<b>F8-5447S</b>		
Stabiliser Mounting	1.4, 1.8 D, 1.8 Turbo D		<b>F8-6034</b>		d=16
Suspension Strut Mounting	1.4, 1.8 D, 1.8 Turbo D		<b>F8-6356</b>		
Engine Mounting	1.8 D, 1.8 Turbo D		<b>F8-6503</b>		
Engine Mounting	1.8 D, 1.8 Turbo D	Transmission Nr: B5, IB5;	<b>F8-6833</b>		
Engine Mounting	1.8 D, 1.8 Turbo D		<b>F8-6952</b>		
Control Arm-/Trailing Arm Bush	1.4, 1.8 D, 1.8 Turbo D		<b>G9-585</b>		H1=46; H2=25; d=12; D=46
Control Arm-/Trailing Arm Bush	1.4, 1.8 D, 1.8 Turbo D		<b>G9-586</b>		H1=27; H2=46; d=12; D1=54; D2=62
<b>ESCORT CLASSIC (AAL, ABL)</b>			<b>10/1998 → 07/2000</b>		
Dust Cover Kit, shock absorber	All Models		<b>AK-735017</b>		
Dust Cover Kit, shock absorber	All Models		<b>AK-735082</b>		
Anti-Friction Bearing	All Models		<b>F8-3019</b>		H=14; d1=12; d2=20; D=45
Mounting, axle beam	All Models		<b>F8-5329</b>		H=70; d=12; D=64
Top Strut Mounting	All Models		<b>F8-5406</b>		
Top Strut Mounting	All Models		<b>F8-5447</b>		
Top Strut Mounting	All Models		<b>F8-5447S</b>		



**Article Description****Article Nr.****Fitting Position**

<b>ESCORT CLASSIC (AAL, ABL)</b>				<b>10/1998 → 07/2000</b>	
Mounting, axle beam	All Models		<b>F8-5971</b>		
Stabiliser Mounting	All Models		<b>F8-6034</b>		d=16
Engine Mounting	1.8 TD		<b>F8-6503</b>		
Engine Mounting	1.8 TD	Transmission Nr: B5, IB5	<b>F8-6833</b>		
Control Arm-/Trailing Arm Bush	All Models		<b>G9-585</b>		H1=46; H2=25; d=12; D=46
Control Arm-/Trailing Arm Bush	All Models		<b>G9-586</b>		H1=27; H2=46; d=12; D1=54; D2=62
<b>ESCORT CLASSIC Turnier (ANL)</b>				<b>02/1999 → 07/2000</b>	
Dust Cover Kit, shock absorber	All Models		<b>AK-735017</b>		
Anti-Friction Bearing	All Models		<b>F8-3019</b>		H=14; d1=12; d2=20; D=45
Mounting, axle beam	All Models		<b>F8-5329</b>		H=70; d=12; D=64
Top Strut Mounting	All Models		<b>F8-5406</b>		
Top Strut Mounting	All Models		<b>F8-5447</b>		
Top Strut Mounting	All Models		<b>F8-5447S</b>		
Mounting, axle beam	All Models		<b>F8-5971</b>		
Stabiliser Mounting	All Models		<b>F8-6034</b>		d=16
Engine Mounting	1.8 TD		<b>F8-6503</b>		
Engine Mounting	1.8 TD	Transmission Nr: B5, IB5	<b>F8-6833</b>		
Engine Mounting	1.8 TD		<b>F8-6952</b>		
Control Arm-/Trailing Arm Bush	All Models		<b>G9-585</b>		H1=46; H2=25; d=12; D=46
Control Arm-/Trailing Arm Bush	All Models		<b>G9-586</b>		H1=27; H2=46; d=12; D1=54; D2=62
<b>ESCORT Mk III (GAA)</b>				<b>09/1980 → 07/1986</b>	
Dust Cover Kit, shock absorber	1.1, 1.3, 1.6, 1.6 D, 1.6 i, 1.6 RS Turbo, 1.6 XR3i		<b>AK-735005</b>		
Dust Cover Kit, shock absorber	1.1, 1.3, 1.6, 1.6 D, 1.6 i, 1.6 XR3i, RS 1600i		<b>AK-735097</b>		
Anti-Friction Bearing	1.1, 1.3, 1.6, 1.6 D, 1.6 i, 1.6 RS Turbo, 1.6 XR3i		<b>F8-3018</b>		H=11; d1=12; d2=20; D=42.2
Anti-Friction Bearing	1.1, 1.3, 1.6, 1.6 D, 1.6 XR3i	12/1984 →	<b>F8-3020</b>		d=12; d1=12; d2=20; D=54; W=10
Anti-Friction Bearing	1.6 i, 1.6 RS Turbo		<b>F8-3020</b>		d=12; d1=12; d2=20; D=54; W=10
Anti-Friction Bearing	1.1, 1.3, 1.6, 1.6 D, 1.6 i, 1.6 XR3i		<b>F8-3027</b>		H=27; d=12; D1=95; D2=130
Bellow, steering	1.1, 1.3, 1.6, 1.6 D, 1.6 i, 1.6 XR3i		<b>F8-5038</b>		
Control Arm-/Trailing Arm Bush	1.1, 1.3, 1.6, 1.6 D, 1.6 i, 1.6 RS Turbo		<b>F8-5075</b>		H=51; d=10; D=33
Control Arm-/Trailing Arm Bush	1.1, 1.6, 1.6 XR3i, RS 1600i	06/1983 →	<b>F8-5075</b>		H=51; d=10; D=33
Stabiliser Mounting	1.1, 1.3, 1.6		<b>F8-5080</b>		d=22

<b>AK-735005</b>	<b>AK-735017</b>	<b>AK-735097</b>	<b>F8-3018</b>	<b>F8-3019</b>	<b>F8-3020</b>	<b>F8-3027</b>
Ref.Nr.:	Ref.Nr.:	Ref.Nr.:	Ref.Nr.: 6112404	Ref.Nr.: 7331751	Ref.Nr.: 85BB3K099AA	Ref.Nr.: 90170695
<b>F8-5038</b>	<b>F8-5075</b>	<b>F8-5080</b>	<b>F8-5329</b>	<b>F8-5406</b>	<b>F8-5447</b>	<b>F8-5447S</b>
Ref.Nr.: 6127744	Ref.Nr.: 1619120	Ref.Nr.: 1634900	Ref.Nr.: 1E00-28-460B	Ref.Nr.: 7234730	Ref.Nr.: 7350847	Ref.Nr.: 7331751
<b>F8-5507</b>	<b>F8-5971</b>	<b>F8-6034</b>	<b>F8-6503</b>	<b>F8-6833</b>	<b>F8-6952</b>	<b>G9-585</b>
Ref.Nr.: 6119999	Ref.Nr.: AB5K653AC	Ref.Nr.: 7102392	Ref.Nr.: 1 040 404	Ref.Nr.: 91AB6L028CB	Ref.Nr.: 6185027	Ref.Nr.: 1000445

Article Description



Article Nr.

Fitting Position



<b>ESCORT Mk III (GAA)</b>			<b>09/1980 → 07/1986</b>	
Top Strut Mounting	1.1, 1.3, 1.6, 1.6 D, 1.6 i, 1.6 RS Turbo, 1.6 XR3i, RS 1600i		<b>F8-5507</b>	
Top Strut Mounting	1.1, 1.3, 1.6, 1.6 RS Turbo, 1.6 XR3i	12/1984 →;	<b>F8-5880</b>	
Top Strut Mounting	1.1, 1.6, 1.6 D, 1.6 i		<b>F8-5880</b>	
Engine Mounting	1.6 D		<b>F8-6952</b>	
Control Arm-/Trailing Arm Bush	1.1, 1.3, 1.6, 1.6 D, 1.6 i, 1.6 RS Turbo, 1.6 XR3i, RS 1600i		<b>G9-500</b>	H=20; d=16; D=46
Control Arm-/Trailing Arm Bush	1.1, 1.3, 1.6, 1.6 D, 1.6 i, 1.6 XR3i		<b>G9-522</b>	H=51; d=10; D1=33; D2=38
<b>ESCORT Mk III Convertible (ALD)</b>			<b>09/1983 → 12/1985</b>	
Dust Cover Kit, shock absorber	1.6, 1.6 i		<b>AK-735005</b>	
Dust Cover Kit, shock absorber	All Models		<b>AK-735097</b>	
Anti-Friction Bearing	All Models		<b>F8-3018</b>	H=11; d1=12; d2=20; D=42.2
Anti-Friction Bearing	All Models	12/1984 →	<b>F8-3020</b>	d=12; d1=12; d2=20; D=54; W=10
Anti-Friction Bearing	All Models		<b>F8-3027</b>	H=27; d=12; D1=95; D2=130
Bellow, steering	All Models		<b>F8-5038</b>	
Control Arm-/Trailing Arm Bush	1.3, 1.6		<b>F8-5075</b>	H=51; d=10; D=33
Control Arm-/Trailing Arm Bush	1.6 i		<b>F8-5075</b>	H=51; d=10; D=33
Top Strut Mounting	All Models		<b>F8-5507</b>	
Top Strut Mounting	All Models	12/1984 →;	<b>F8-5880</b>	
Control Arm-/Trailing Arm Bush	All Models		<b>G9-500</b>	H=20; d=16; D=46
Control Arm-/Trailing Arm Bush	All Models		<b>G9-522</b>	H=51; d=10; D1=33; D2=38
<b>ESCORT Mk III Estate (AWA)</b>			<b>09/1980 → 12/1985</b>	
Dust Cover Kit, shock absorber	1.1, 1.3, 1.6, 1.6 D		<b>AK-735005</b>	
Dust Cover Kit, shock absorber	1.1, 1.3, 1.6, 1.6 D		<b>AK-735097</b>	
Anti-Friction Bearing	1.1, 1.3, 1.6, 1.6 D		<b>F8-3018</b>	H=11; d1=12; d2=20; D=42.2
Anti-Friction Bearing	1.1, 1.3, 1.6, 1.6 D	12/1984 →	<b>F8-3020</b>	d=12; d1=12; d2=20; D=54; W=10
Anti-Friction Bearing	1.1, 1.3, 1.6, 1.6 D		<b>F8-3027</b>	H=27; d=12; D1=95; D2=130
Bellow, steering	1.1, 1.3, 1.6, 1.6 D		<b>F8-5038</b>	
Control Arm-/Trailing Arm Bush	1.1, 1.3, 1.6	06/1983 →	<b>F8-5075</b>	H=51; d=10; D=33
Control Arm-/Trailing Arm Bush	1.1, 1.6 D		<b>F8-5075</b>	H=51; d=10; D=33
Stabiliser Mounting	1.1, 1.3, 1.6		<b>F8-5080</b>	d=22

<b>AK-735005</b>	<b>AK-735097</b>	<b>F8-3018</b>	<b>F8-3020</b>	<b>F8-3027</b>	<b>F8-5038</b>	<b>F8-5075</b>
Ref.Nr.:	Ref.Nr.:	Ref.Nr.: 6112404	Ref.Nr.: 85BB3K099AA	Ref.Nr.: 90170695	Ref.Nr.: 6127744	Ref.Nr.: 1619120
<b>F8-5080</b>	<b>F8-5507</b>	<b>F8-5880</b>	<b>F8-6952</b>	<b>G9-500</b>	<b>G9-522</b>	
Ref.Nr.: 1634900	Ref.Nr.: 6119999	Ref.Nr.: 6150276	Ref.Nr.: 6185027	Ref.Nr.: 6107025	Ref.Nr.: 1619120	

**Article Description****Article Nr.****Fitting Position**

<b>ESCORT Mk III Estate (AWA)</b>			<b>09/1980 → 12/1985</b>		
Top Strut Mounting	1.1, 1.3, 1.6, 1.6 D		<b>F8-5507</b>		
Top Strut Mounting	1.1, 1.3, 1.6	12/1984 →;	<b>F8-5880</b>		
Top Strut Mounting	1.1, 1.6 D		<b>F8-5880</b>		
Engine Mounting	1.6 D		<b>F8-6952</b>		
Control Arm-/Trailing Arm Bush	1.1, 1.3, 1.6, 1.6 D		<b>G9-500</b>		H=20; d=16; D=46
Control Arm-/Trailing Arm Bush	1.1, 1.3, 1.6, 1.6 D		<b>G9-522</b>		H=51; d=10; D1=33; D2=38
<b>ESCORT Mk IV (GAF, AWF, ABFT)</b>			<b>10/1985 → 10/1990</b>		
Dust Cover Kit, shock absorber	1.1, 1.3, 1.4, 1.6, 1.6 D, 1.6 i, 1.6 Turbo RS, 1.6 XR3i, 1.8 D		<b>AK-735005</b>		
Dust Cover Kit, shock absorber	All Models		<b>AK-735097</b>		
Anti-Friction Bearing	1.1, 1.3, 1.4, 1.6, 1.6 D, 1.6 i, 1.6 Turbo RS, 1.6 XR3i, 1.8 D		<b>F8-3018</b>		H=11; d1=12; d2=20; D=42.2
Anti-Friction Bearing	1.1, 1.3, 1.4, 1.6, 1.6 D, 1.6 i, 1.6 Turbo RS, 1.6 XR3i, 1.8 D		<b>F8-3020</b>		d=12; d1=12; d2=20; D=54; W=10
Anti-Friction Bearing	1.1, 1.3, 1.4, 1.6, 1.6 D, 1.6 i, 1.6 Turbo RS, 1.6 XR3i, 1.8 D		<b>F8-3027</b>		H=27; d=12; D1=95; D2=130
Bellow, steering	1.1, 1.3, 1.4, 1.6 D, 1.6 i, 1.6 XR3i		<b>F8-5038</b>		
Stabiliser Mounting	1.1, 1.3, 1.4, 1.6, 1.6 D, 1.6 i, 1.6 XR3i, 1.8 D		<b>F8-5070</b>		d=24
Stabiliser Mounting	1.3, 1.4, 1.6, 1.6 Turbo RS		<b>F8-5070</b>		d=24
Control Arm-/Trailing Arm Bush	1.1, 1.3, 1.4, 1.6, 1.6 D, 1.6 i, 1.6 Turbo RS, 1.6 XR3i	09/1988 →	<b>F8-5075</b>		H=51; d=10; D=33
Control Arm-/Trailing Arm Bush	1.3, 1.6, 1.6 i, 1.8 D		<b>F8-5075</b>		H=51; d=10; D=33
Stabiliser Mounting	1.1, 1.3, 1.4, 1.6, 1.6 D, 1.6 i, 1.6 XR3i, 1.8 D		<b>F8-5080</b>		d=22
Stabiliser Mounting	1.3, 1.4, 1.6, 1.6 Turbo RS		<b>F8-5080</b>		d=22
Top Strut Mounting	All Models		<b>F8-5507</b>		
Top Strut Mounting	1.1, 1.4	01/1986 →;	<b>F8-5880</b>		
Top Strut Mounting	1.3, 1.4, 1.6, 1.6 D, 1.6 i, 1.6 Turbo RS, 1.6 XR3i, 1.8 D		<b>F8-5880</b>		
Engine Mounting	1.8 D		<b>F8-6492</b>		
Engine Mounting	1.6 D	08/1988 →	<b>F8-6506</b>		
Engine Mounting	1.8 D		<b>F8-6506</b>		
Engine Mounting	1.1, 1.3		<b>F8-6929</b>		
Engine Mounting	1.8 D		<b>F8-6952</b>		
Engine Mounting	1.8 D		<b>F8-6953</b>		
Control Arm-/Trailing Arm Bush	All Models		<b>G9-500</b>		H=20; d=16; D=46

<b>AK-735005</b>	<b>AK-735097</b>	<b>F8-3018</b>	<b>F8-3020</b>	<b>F8-3027</b>	<b>F8-5038</b>	<b>F8-5070</b>
Ref.Nr.:	Ref.Nr.:	Ref.Nr.: 6112404	Ref.Nr.: 85BB3K099AA	Ref.Nr.: 90170695	Ref.Nr.: 6127744	Ref.Nr.: 1634901
<b>F8-5075</b>	<b>F8-5080</b>	<b>F8-5507</b>	<b>F8-5880</b>	<b>F8-6492</b>	<b>F8-6506</b>	<b>F8-6929</b>
Ref.Nr.: 1619120	Ref.Nr.: 1634900	Ref.Nr.: 6119999	Ref.Nr.: 6150276	Ref.Nr.: 1 661 786	Ref.Nr.: 6203710	Ref.Nr.: 84FB6038AE
<b>F8-6952</b>	<b>F8-6953</b>	<b>G9-500</b>	<b>G9-522</b>			
Ref.Nr.: 6185027	Ref.Nr.: 6178901	Ref.Nr.: 6107025	Ref.Nr.: 1619120			

Article Description



Article Nr.

Fitting Position



<b>ESCORT Mk IV (GAF, AWF, ABFT)</b>		<b>10/1985 → 10/1990</b>	
Control Arm-/Trailing Arm Bush	All Models	G9-522	
<b>ESCORT Mk IV Convertible (ALF)</b>		<b>01/1986 → 07/1990</b>	
Dust Cover Kit, shock absorber	1.4, 1.6 i, 1.6 XR3i	AK-735005	
Dust Cover Kit, shock absorber	All Models	AK-735097	
Anti-Friction Bearing	1.4, 1.6 i, 1.6 XR3i	F8-3018	
Anti-Friction Bearing	All Models	F8-3020	
Anti-Friction Bearing	1.4, 1.6 i, 1.6 XR3i	F8-3027	
Bellow, steering	1.4, 1.6 i, 1.6 XR3i	F8-5038	
Stabiliser Mounting	1.4, 1.6 i, 1.6 XR3i	F8-5070	
Stabiliser Mounting	1.6	F8-5070	
Control Arm-/Trailing Arm Bush	1.4, 1.6 i, 1.6 XR3i	F8-5075	
Control Arm-/Trailing Arm Bush	1.6 i	F8-5075	
Stabiliser Mounting	1.4, 1.6 i, 1.6 XR3i	F8-5080	
Stabiliser Mounting	1.6	F8-5080	
Top Strut Mounting	All Models	F8-5507	
Top Strut Mounting	All Models	F8-5880	
Control Arm-/Trailing Arm Bush	All Models	G9-500	
Control Arm-/Trailing Arm Bush	All Models	G9-522	
<b>ESCORT Mk IV Estate (AWF, AVF)</b>		<b>10/1985 → 10/1990</b>	
Dust Cover Kit, shock absorber	1.3, 1.4, 1.6 D, 1.6 i, 1.8 D	AK-735005	
Dust Cover Kit, shock absorber	1.1, 1.3, 1.4, 1.6, 1.6 D, 1.6 i, 1.8 D	AK-735097	
Anti-Friction Bearing	1.1, 1.3, 1.4, 1.6 D, 1.6 i, 1.8 D	F8-3018	
Anti-Friction Bearing	1.1, 1.3, 1.4, 1.6, 1.6 D, 1.6 i, 1.8 D	F8-3020	
Anti-Friction Bearing	1.1, 1.3, 1.4, 1.6 D, 1.6 i, 1.8 D	F8-3027	
Bellow, steering	1.3, 1.4, 1.6 D, 1.6 i	F8-5038	
Stabiliser Mounting	1.1, 1.3, 1.4, 1.6	F8-5070	
Stabiliser Mounting	1.3, 1.4, 1.6 D, 1.6 i, 1.8 D	F8-5070	
Control Arm-/Trailing Arm Bush	1.1, 1.3, 1.4, 1.6, 1.6 D, 1.6 i, 1.8 D	F8-5075	
Control Arm-/Trailing Arm Bush	1.4	F8-5075	
Stabiliser Mounting	1.1, 1.3, 1.4, 1.6	F8-5080	
Stabiliser Mounting	1.3, 1.4, 1.6 D, 1.6 i, 1.8 D	F8-5080	

<b>AK-735005</b>	<b>AK-735097</b>	<b>F8-3018</b>	<b>F8-3020</b>	<b>F8-3027</b>	<b>F8-5038</b>	<b>F8-5070</b>
Ref.Nr.:	Ref.Nr.:	Ref.Nr.: 6112404	Ref.Nr.: 85BB3K099AA	Ref.Nr.: 90170695	Ref.Nr.: 6127744	Ref.Nr.: 1634901
<b>F8-5075</b>	<b>F8-5080</b>	<b>F8-5507</b>	<b>F8-5880</b>	<b>G9-500</b>	<b>G9-522</b>	
Ref.Nr.: 1619120	Ref.Nr.: 1634900	Ref.Nr.: 6119999	Ref.Nr.: 6150276	Ref.Nr.: 6107025	Ref.Nr.: 1619120	

**Article Description****Article Nr.****Fitting Position****ESCORT Mk IV Estate (AWF, AVF)****10/1985 → 10/1990**

Top Strut Mounting	1.1, 1.3, 1.4, 1.6, 1.6 D, 1.6 i, 1.8 D		<b>F8-5507</b>				
Top Strut Mounting	1.1, 1.4	01/1986 →;	<b>F8-5880</b>				
Top Strut Mounting	1.3, 1.4, 1.6, 1.6 D, 1.6 i, 1.8 D		<b>F8-5880</b>				
Engine Mounting	1.8 D		<b>F8-6492</b>				
Engine Mounting	1.6 D	08/1988 →	<b>F8-6506</b>				
Engine Mounting	1.8 D		<b>F8-6506</b>				
Engine Mounting	1.3		<b>F8-6929</b>				
Engine Mounting	1.6 D, 1.8 D		<b>F8-6952</b>				
Engine Mounting	1.8 D		<b>F8-6953</b>				
Control Arm-/Trailing Arm Bush	1.1, 1.3, 1.4, 1.6, 1.6 D, 1.6 i, 1.8 D		<b>G9-500</b>				H=20; d=16; D=46
Control Arm-/Trailing Arm Bush	1.1, 1.3, 1.4, 1.6, 1.6 D, 1.6 i, 1.8 D		<b>G9-522</b>				H=51; d=10; D1=33; D2=38

**ESCORT Mk V (GAL)****07/1990 → 12/1992**

Dust Cover Kit, shock absorber	1.8 16V XR3i, RS 2000		<b>AK-735005</b>				
Dust Cover Kit, shock absorber	1.8 16V XR3i		<b>AK-735097</b>				
Anti-Friction Bearing	All Models		<b>F8-3018</b>				H=11; d1=12; d2=20; D=42.2
Anti-Friction Bearing	All Models		<b>F8-3020</b>				d=12; d1=12; d2=20; D=54; W=10
Anti-Friction Bearing	All Models		<b>F8-3027</b>				H=27; d=12; D1=95; D2=130
Mounting, axle beam	1.3		<b>F8-5329</b>				H=70; d=12; D=64
Top Strut Mounting	All Models		<b>F8-5522</b>				
Engine Mounting	1.8 D		<b>F8-5561</b>				
Stabiliser Mounting	All Models		<b>F8-6034</b>				d=16
Top Strut Mounting	All Models		<b>F8-6307</b>				
Suspension Strut Mounting	All Models		<b>F8-6356</b>				
Engine Mounting	1.8 16V XR3i, RS 2000		<b>F8-6503</b>				
Engine Mounting	1.8 D	08/1990 →	<b>F8-6503</b>				
Engine Mounting	1.8 16V XR3i, 1.8 D	Transmission Nr: B5, IB5;	<b>F8-6833</b>				
Engine Mounting	1.8 D		<b>F8-6952</b>				
Mounting, axle beam	All Models		<b>F8-7935</b>				
Control Arm-/Trailing Arm Bush	RS 2000		<b>G9-501</b>				H=23; d=16; D1=49; D2=65
Control Arm-/Trailing Arm Bush	RS 2000		<b>G9-501S</b>				H=23; d=16; D1=49; D2=65
Control Arm-/Trailing Arm Bush	RS 2000		<b>G9-524</b>				H=52; d=12.1; D1=31.5; D2=40

<b>AK-735005</b>	<b>AK-735097</b>	<b>F8-3018</b>	<b>F8-3020</b>	<b>F8-3027</b>	<b>F8-5329</b>	<b>F8-5507</b>
Ref.Nr.:	Ref.Nr.:	Ref.Nr.: 6112404	Ref.Nr.: 85BB3K099AA	Ref.Nr.: 90170695	Ref.Nr.: 1E00-28-460B	Ref.Nr.: 6119999
<b>F8-5522</b>	<b>F8-5561</b>	<b>F8-5880</b>	<b>F8-6034</b>	<b>F8-6307</b>	<b>F8-6356</b>	<b>F8-6492</b>
Ref.Nr.: 6495311	Ref.Nr.: 6 160 229	Ref.Nr.: 6150276	Ref.Nr.: 7102392	Ref.Nr.: 6112404	Ref.Nr.: 89FB-5599-AC	Ref.Nr.: 1 661 786
<b>F8-6503</b>	<b>F8-6506</b>	<b>F8-6833</b>	<b>F8-6929</b>	<b>F8-6952</b>	<b>F8-6953</b>	<b>F8-7935</b>
Ref.Nr.: 1 040 404	Ref.Nr.: 6203710	Ref.Nr.: 91AB6L028CB	Ref.Nr.: 84FB6038AE	Ref.Nr.: 6185027	Ref.Nr.: 6178901	Ref.Nr.: 6745350

Article Description			Article Nr.	Fitting Position	
---------------------	--	--	-------------	------------------	--

<b>ESCORT Mk V (GAL)</b>			<b>07/1990 → 12/1992</b>		
Control Arm-/Trailing Arm Bush	All Models		<b>G9-585</b>		H1=46; H2=25; d=12; D=46
Control Arm-/Trailing Arm Bush	All Models		<b>G9-586</b>		H1=27; H2=46; d=12; D1=54; D2=62
<b>ESCORT Mk V Convertible (ALL)</b>			<b>07/1990 → 12/1992</b>		
Dust Cover Kit, shock absorber	1.8 16V XR3i		<b>AK-735005</b>		
Anti-Friction Bearing	All Models		<b>F8-3018</b>		H=11; d1=12; d2=20; D=42.2
Anti-Friction Bearing	All Models		<b>F8-3020</b>		d=12; d1=12; d2=20; D=54; W=10
Anti-Friction Bearing	All Models		<b>F8-3027</b>		H=27; d=12; D1=95; D2=130
Top Strut Mounting	All Models		<b>F8-5522</b>		
Stabiliser Mounting	All Models		<b>F8-6034</b>		d=16
Top Strut Mounting	All Models		<b>F8-6307</b>		
Suspension Strut Mounting	All Models		<b>F8-6356</b>		
Engine Mounting	1.8 16V XR3i		<b>F8-6503</b>		
Engine Mounting	1.8 16V XR3i	Transmission Nr: B5, IB5;	<b>F8-6833</b>		
Mounting, axle beam	All Models		<b>F8-7935</b>		
Control Arm-/Trailing Arm Bush	All Models		<b>G9-585</b>		H1=46; H2=25; d=12; D=46
Control Arm-/Trailing Arm Bush	All Models		<b>G9-586</b>		H1=27; H2=46; d=12; D1=54; D2=62
<b>ESCORT Mk V Estate (GAL, AVL)</b>			<b>07/1990 → 12/1992</b>		
Anti-Friction Bearing	1.3, 1.4, 1.6, 1.8 16V, 1.8 D		<b>F8-3018</b>		H=11; d1=12; d2=20; D=42.2
Anti-Friction Bearing	1.3, 1.4, 1.6, 1.8 16V, 1.8 D		<b>F8-3020</b>		d=12; d1=12; d2=20; D=54; W=10
Anti-Friction Bearing	1.3, 1.4, 1.6, 1.8 16V, 1.8 D		<b>F8-3027</b>		H=27; d=12; D1=95; D2=130
Top Strut Mounting	1.3, 1.4, 1.6, 1.8 16V, 1.8 D		<b>F8-5522</b>		
Engine Mounting	1.8 D		<b>F8-5561</b>		
Stabiliser Mounting	1.3, 1.4, 1.6, 1.8 16V, 1.8 D		<b>F8-6034</b>		d=16
Top Strut Mounting	1.3, 1.4, 1.6, 1.8 16V, 1.8 D		<b>F8-6307</b>		
Engine Mounting	1.8 16V, 1.8 D		<b>F8-6503</b>		
Engine Mounting	1.8 16V, 1.8 D	Transmission Nr: B5, IB5;	<b>F8-6833</b>		
Engine Mounting	1.4, 1.8 D		<b>F8-6952</b>		
Mounting, axle beam	All Models		<b>F8-7935</b>		
Control Arm-/Trailing Arm Bush	1.3, 1.4, 1.6, 1.8 16V, 1.8 D		<b>G9-585</b>		H1=46; H2=25; d=12; D=46
Control Arm-/Trailing Arm Bush	1.3, 1.4, 1.6, 1.8 16V, 1.8 D		<b>G9-586</b>		H1=27; H2=46; d=12; D1=54; D2=62

<b>AK-735005</b>	<b>F8-3018</b>	<b>F8-3020</b>	<b>F8-3027</b>	<b>F8-5522</b>	<b>F8-5561</b>	<b>F8-6034</b>
Ref.Nr.:	Ref.Nr.: 6112404	Ref.Nr.: 85BB3K099AA	Ref.Nr.: 90170695	Ref.Nr.: 6495311	Ref.Nr.: 6 160 229	Ref.Nr.: 7102392
<b>F8-6307</b>	<b>F8-6356</b>	<b>F8-6503</b>	<b>F8-6833</b>	<b>F8-6952</b>	<b>F8-7935</b>	<b>G9-585</b>
Ref.Nr.: 6112404	Ref.Nr.: 89FB-5599-AC	Ref.Nr.: 1 040 404	Ref.Nr.: 91AB6L028CB	Ref.Nr.: 6185027	Ref.Nr.: 6745350	Ref.Nr.: 1000445
<b>G9-586</b>						
Ref.Nr.: 1035929						



**Article Description****Article Nr.****Fitting Position****ESCORT Mk VI (GAL) 09/1992 → 01/1995**

Dust Cover Kit, shock absorber	1.8 XR3i 16V 4x4, RS 2000, RS 2000 4x4		<b>AK-735005</b>				
Anti-Friction Bearing	1.3, 1.4, 1.6 i 16V, 1.8 D, 1.8 i 16V, 1.8 TD, 1.8 XR3i 16V 4x4, RS 2000, RS 2000 4x4, RS Cosworth 4x4		<b>F8-3018</b>				H=11; d1=12; d2=20; D=42.2
Anti-Friction Bearing	1.8 TD		<b>F8-3019</b>				H=14; d1=12; d2=20; D=45
Anti-Friction Bearing	1.3, 1.4, 1.6 i 16V, 1.8 D, 1.8 i 16V, 1.8 TD, 1.8 XR3i 16V 4x4, RS 2000, RS 2000 4x4, RS Cosworth 4x4		<b>F8-3020</b>				d=12; d1=12; d2=20; D=54; W=10
Anti-Friction Bearing	1.3, 1.4, 1.6 i 16V, 1.8 D, 1.8 i 16V, 1.8 TD, 1.8 XR3i 16V 4x4, RS 2000, RS 2000 4x4, RS Cosworth 4x4		<b>F8-3027</b>				H=27; d=12; D1=95; D2=130
Mounting, axle beam	1.3, 1.4, 1.6 i 16V, 1.8 TD, RS Cosworth 4x4		<b>F8-5329</b>				H=70; d=12; D=64
Top Strut Mounting	1.8 TD	Hatchback;	<b>F8-5406</b>				
Top Strut Mounting	1.3, 1.4, 1.6 i 16V, 1.8 16V XR3i, 1.8 D, 1.8 i 16V, 1.8 TD, 1.8 XR3i 16V 4x4, RS 2000 4x4, RS Cosworth 4x4		<b>F8-5522</b>				
Engine Mounting	1.8 D, 1.8 TD		<b>F8-5561</b>				
Stabiliser Mounting	All Models		<b>F8-6034</b>				d=16
Top Strut Mounting	All Models		<b>F8-6307</b>				
Suspension Strut Mounting	All Models		<b>F8-6356</b>				
Engine Mounting	1.6 i 16V, 1.8 16V XR3i, 1.8 D, 1.8 i 16V, 1.8 TD, 1.8 XR3i 16V 4x4, RS 2000, RS 2000 4x4, RS Cosworth 4x4		<b>F8-6503</b>				
Engine Mounting	1.6 i 16V, 1.8 D, 1.8 i 16V, 1.8 TD, 1.8 XR3i 16V 4x4, RS 2000	Transmission Nr: B5, IB5;	<b>F8-6833</b>				
Engine Mounting	1.8 16V XR3i	Transmission Nr: B5, IB5	<b>F8-6833</b>				
Engine Mounting	1.8 D, 1.8 TD		<b>F8-6952</b>				
Mounting, axle beam	All Models		<b>F8-7935</b>				
Control Arm-/Trailing Arm Bush	RS 2000, RS 2000 4x4, RS Cosworth 4x4		<b>G9-501</b>				H=23; d=16; D1=49; D2=65
Control Arm-/Trailing Arm Bush	RS 2000, RS 2000 4x4, RS Cosworth 4x4		<b>G9-501S</b>				H=23; d=16; D1=49; D2=65
Control Arm-/Trailing Arm Bush	RS 2000, RS 2000 4x4, RS Cosworth 4x4		<b>G9-524</b>				H=52; d=12.1; D1=31.5; D2=40
Control Arm-/Trailing Arm Bush	All Models		<b>G9-585</b>				H1=46; H2=25; d=12; D=46
Control Arm-/Trailing Arm Bush	All Models		<b>G9-586</b>				H1=27; H2=46; d=12; D1=54; D2=62

**ESCORT Mk VI Convertible (ALL) 12/1992 → 01/1995**

Anti-Friction Bearing	All Models		<b>F8-3018</b>				H=11; d1=12; d2=20; D=42.2
Anti-Friction Bearing	All Models		<b>F8-3020</b>				d=12; d1=12; d2=20; D=54; W=10
Anti-Friction Bearing	All Models		<b>F8-3027</b>				H=27; d=12; D1=95; D2=130
Mounting, axle beam	1.4 i, 1.6 16V XR3i, 1.6 i 16V		<b>F8-5329</b>				H=70; d=12; D=64
Top Strut Mounting	All Models		<b>F8-5522</b>				

<b>AK-735005</b>	<b>F8-3018</b>	<b>F8-3019</b>	<b>F8-3020</b>	<b>F8-3027</b>	<b>F8-5329</b>	<b>F8-5406</b>
Ref.Nr.:	Ref.Nr.: 6112404	Ref.Nr.: 7331751	Ref.Nr.: 85BB3K099AA	Ref.Nr.: 90170695	Ref.Nr.: 1E00-28-460B	Ref.Nr.: 7234730
<b>F8-5522</b>	<b>F8-5561</b>	<b>F8-6034</b>	<b>F8-6307</b>	<b>F8-6356</b>	<b>F8-6503</b>	<b>F8-6833</b>
Ref.Nr.: 6495311	Ref.Nr.: 6 160 229	Ref.Nr.: 7102392	Ref.Nr.: 6112404	Ref.Nr.: 89FB-5599-AC	Ref.Nr.: 1 040 404	Ref.Nr.: 91AB6L028CB
<b>F8-6952</b>	<b>F8-7935</b>	<b>G9-501</b>	<b>G9-501S</b>	<b>G9-524</b>	<b>G9-585</b>	<b>G9-586</b>
Ref.Nr.: 6185027	Ref.Nr.: 6745350	Ref.Nr.: 5021729	Ref.Nr.: 6122507	Ref.Nr.: 1632679	Ref.Nr.: 1000445	Ref.Nr.: 1035929

Article Description

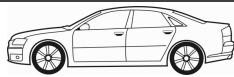

Article Nr.

Fitting Position



<b>ESCORT Mk VI Convertible (ALL)</b>			<b>12/1992 → 01/1995</b>		
Stabiliser Mounting	All Models		<b>F8-6034</b>		d=16
Top Strut Mounting	All Models		<b>F8-6307</b>		
Suspension Strut Mounting	All Models		<b>F8-6356</b>		
Engine Mounting	1.6 16V XR3i, 1.6 i 16V, 1.8 16V XR3i		<b>F8-6503</b>		
Engine Mounting	1.6 16V XR3i, 1.6 i 16V	Transmission Nr: B5, IB5;	<b>F8-6833</b>		
Engine Mounting	1.8 16V XR3i	Transmission Nr: B5, IB5	<b>F8-6833</b>		
Mounting, axle beam	All Models		<b>F8-7935</b>		
Control Arm-/Trailing Arm Bush	All Models		<b>G9-585</b>		H1=46; H2=25; d=12; D=46
Control Arm-/Trailing Arm Bush	All Models		<b>G9-586</b>		H1=27; H2=46; d=12; D1=54; D2=62
<b>ESCORT Mk VI Estate (GAL)</b>			<b>09/1992 → 01/1995</b>		
Anti-Friction Bearing	All Models		<b>F8-3018</b>		H=11; d1=12; d2=20; D=42.2
Anti-Friction Bearing	All Models		<b>F8-3020</b>		d=12; d1=12; d2=20; D=54; W=10
Anti-Friction Bearing	All Models		<b>F8-3027</b>		H=27; d=12; D1=95; D2=130
Mounting, axle beam	1.4, 1.6 i 16V, 1.8 TD		<b>F8-5329</b>		H=70; d=12; D=64
Top Strut Mounting	All Models		<b>F8-5522</b>		
Engine Mounting	1.8 D, 1.8 TD		<b>F8-5561</b>		
Stabiliser Mounting	All Models		<b>F8-6034</b>		d=16
Top Strut Mounting	All Models		<b>F8-6307</b>		
Engine Mounting	1.6 i 16V, 1.8 D, 1.8 i 16V, 1.8 TD		<b>F8-6503</b>		
Engine Mounting	1.6 i 16V, 1.8 D, 1.8 i 16V, 1.8 TD	Transmission Nr: B5, IB5;	<b>F8-6833</b>		
Engine Mounting	1.8 D, 1.8 TD		<b>F8-6952</b>		
Mounting, axle beam	All Models		<b>F8-7935</b>		
Control Arm-/Trailing Arm Bush	All Models		<b>G9-585</b>		H1=46; H2=25; d=12; D=46
Control Arm-/Trailing Arm Bush	All Models		<b>G9-586</b>		H1=27; H2=46; d=12; D1=54; D2=62
<b>ESCORT Mk VI Saloon (GAL)</b>			<b>08/1993 → 01/1995</b>		
Anti-Friction Bearing	All Models		<b>F8-3018</b>		H=11; d1=12; d2=20; D=42.2
Anti-Friction Bearing	All Models		<b>F8-3020</b>		d=12; d1=12; d2=20; D=54; W=10
Anti-Friction Bearing	All Models		<b>F8-3027</b>		H=27; d=12; D1=95; D2=130
Mounting, axle beam	1.4, 1.6 i 16V		<b>F8-5329</b>		H=70; d=12; D=64
Top Strut Mounting	1.6 i 16V		<b>F8-5406</b>		
Top Strut Mounting	All Models		<b>F8-5522</b>		
Engine Mounting	1.8 D, 1.8 TD		<b>F8-5561</b>		

<b>F8-3018</b>	<b>F8-3020</b>	<b>F8-3027</b>	<b>F8-5329</b>	<b>F8-5406</b>	<b>F8-5522</b>	<b>F8-5561</b>
Ref.Nr.: 6112404	Ref.Nr.: 85BB3K099AA	Ref.Nr.: 90170695	Ref.Nr.: 1E00-28-460B	Ref.Nr.: 7234730	Ref.Nr.: 6495311	Ref.Nr.: 6 160 229
<b>F8-6034</b>	<b>F8-6307</b>	<b>F8-6356</b>	<b>F8-6503</b>	<b>F8-6833</b>	<b>F8-6952</b>	<b>F8-7935</b>
Ref.Nr.: 7102392	Ref.Nr.: 6112404	Ref.Nr.: 89FB-5599-AC	Ref.Nr.: 1 040 404	Ref.Nr.: 91AB6L028CB	Ref.Nr.: 6185027	Ref.Nr.: 6745350
<b>G9-585</b>	<b>G9-586</b>					
Ref.Nr.: 1000445	Ref.Nr.: 1035929					

**Article Description****Article Nr.****Fitting Position**

<b>ESCORT Mk VI Saloon (GAL)</b>		<b>08/1993 → 01/1995</b>	
Stabiliser Mounting	All Models	<b>F8-6034</b>	⊕ ⊕ ⊕ d=16
Top Strut Mounting	All Models	<b>F8-6307</b>	
Suspension Strut Mounting	All Models	<b>F8-6356</b>	
Engine Mounting	1.6 i 16V, 1.8 D, 1.8 i 16V, 1.8 TD	<b>F8-6503</b>	⊕
Engine Mounting	1.6 i 16V, 1.8 D, 1.8 i 16V, 1.8 TD	<b>F8-6833</b>	⊕ Transmission Nr: B5, IB5;
Engine Mounting	1.8 D, 1.8 TD	<b>F8-6952</b>	⊕
Mounting, axle beam	All Models	<b>F8-7935</b>	⊕ ⊕ ⊕
Control Arm-/Trailing Arm Bush	All Models	<b>G9-585</b>	⊕ ⊕ ⊕ H1=46; H2=25; d=12; D=46
Control Arm-/Trailing Arm Bush	All Models	<b>G9-586</b>	⊕ ⊕ ⊕ ↓ H1=27; H2=46; d=12; D1=54; D2=62
<b>ESCORT Mk VII (GAL, AAL, ABL)</b>		<b>01/1995 → 10/1998</b>	
Dust Cover Kit, shock absorber	RS 2000	<b>AK-735005</b>	⊕ ⊕ ⊕
Dust Cover Kit, shock absorber	1.3, 1.4, 1.6 16V, 1.6 16V 4x4, 1.6 i 16V, 1.8 16V, 1.8 D, 1.8 TD, 1.8 Turbo D	<b>AK-735017</b>	⊕ ⊕ ⊕
Dust Cover Kit, shock absorber	1.3, 1.4, 1.6 16V, 1.6 i 16V, 1.8 16V, 1.8 D, 1.8 TD, 1.8 Turbo D	<b>AK-735082</b>	
Anti-Friction Bearing	1.3, 1.4, 1.6 16V, 1.6 16V 4x4, 1.6 i 16V, 1.8 16V, 1.8 D, 1.8 TD, 1.8 Turbo D, RS 2000, RS 2000 4x4, RS Cosworth 4x4	<b>F8-3019</b>	H=14; d1=12; d2=20; D=45
Anti-Friction Bearing	RS Cosworth 4x4	<b>F8-3020</b>	⊕ ⊕ ⊕ d=12; d1=12; d2=20; D=54; W=10
Mounting, axle beam	1.3, 1.4, 1.6 16V, 1.6 i 16V, 1.8 16V, 1.8 D, 1.8 TD, 1.8 Turbo D, RS Cosworth 4x4	<b>F8-5329</b>	H=70; d=12; D=64
Top Strut Mounting	1.3, 1.4, 1.6 16V, 1.6 i 16V, 1.8 16V, 1.8 D, 1.8 TD, 1.8 Turbo D, RS 2000, RS Cosworth 4x4	<b>F8-5406</b>	⊕ ⊕ ⊕
Top Strut Mounting	1.3, 1.4, 1.6 16V, 1.6 16V 4x4, 1.6 i 16V, 1.8 16V, 1.8 D, 1.8 TD, 1.8 Turbo D, RS 2000, RS 2000 4x4, RS Cosworth 4x4	<b>F8-5447</b>	⊕ ⊕ ⊕
Top Strut Mounting	1.3, 1.4, 1.6 16V, 1.6 16V 4x4, 1.6 i 16V, 1.8 16V, 1.8 D, 1.8 TD, 1.8 Turbo D, RS 2000, RS 2000 4x4, RS Cosworth 4x4	<b>F8-5447S</b>	⊕ ⊕ ⊕
Top Strut Mounting	RS Cosworth 4x4	<b>F8-5507</b>	⊕ ⊕ ⊕
Engine Mounting	1.8 D	<b>F8-5561</b>	
Mounting, axle beam	1.3, 1.4, 1.6 16V, 1.6 i 16V, 1.8 16V, 1.8 D, 1.8 TD, 1.8 Turbo D, RS 2000 4x4, RS Cosworth 4x4	<b>F8-5971</b>	⊕ ⊕ ⊕
Stabiliser Mounting	1.3, 1.4, 1.6 16V, 1.6 16V 4x4, 1.6 i 16V, 1.8 16V, 1.8 D, 1.8 TD, 1.8 Turbo D, RS 2000, RS 2000 4x4, RS Cosworth 4x4	<b>F8-6034</b>	⊕ ⊕ ⊕ d=16
Suspension Strut Mounting	1.3, 1.4, 1.6 16V, 1.6 i 16V, 1.8 16V, 1.8 D, 1.8 TD, 1.8 Turbo D	<b>F8-6356</b>	

<b>AK-735005</b>	<b>AK-735017</b>	<b>AK-735082</b>	<b>F8-3019</b>	<b>F8-3020</b>	<b>F8-5329</b>	<b>F8-5406</b>
Ref.Nr.:	Ref.Nr.:	Ref.Nr.:	Ref.Nr.: 7331751	Ref.Nr.: 85BB3K099AA	Ref.Nr.: 1E00-28-460B	Ref.Nr.: 7234730
<b>F8-5447</b>	<b>F8-5447S</b>	<b>F8-5507</b>	<b>F8-5561</b>	<b>F8-5971</b>	<b>F8-6034</b>	<b>F8-6307</b>
Ref.Nr.: 7350847	Ref.Nr.: 7331751	Ref.Nr.: 6119999	Ref.Nr.: 6 160 229	Ref.Nr.: AB5K653AC	Ref.Nr.: 7102392	Ref.Nr.: 6112404
<b>F8-6356</b>	<b>F8-6503</b>	<b>F8-6833</b>	<b>F8-6952</b>	<b>F8-7935</b>	<b>G9-585</b>	<b>G9-586</b>
Ref.Nr.: 89FB-5599-AC	Ref.Nr.: 1 040 404	Ref.Nr.: 91AB6L028CB	Ref.Nr.: 6185027	Ref.Nr.: 6745350	Ref.Nr.: 1000445	Ref.Nr.: 1035929

Article Description

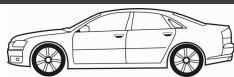

Article Nr.

Fitting Position



**ESCORT Mk VII (GAL, AAL, ABL) 01/1995 → 10/1998**

Engine Mounting	1.6 16V, 1.6 16V 4x4, 1.6 i 16V, 1.8 16V, 1.8 D, 1.8 TD, 1.8 Turbo D, RS 2000, RS 2000 4x4, RS Cosworth 4x4		F8-6503	⊕	
Spring Cap	1.3, 1.4, 1.6 16V, 1.6 16V 4x4, 1.6 i 16V, 1.8 16V, 1.8 D, 1.8 TD, 1.8 Turbo D, RS 2000, RS 2000 4x4, RS Cosworth 4x4		F8-6557	🚗	
Engine Mounting	1.6 16V, 1.6 16V 4x4, 1.6 i 16V, 1.8 16V, 1.8 D, 1.8 TD, 1.8 Turbo D, RS 2000	Transmission Nr: B5, IB5; ⚙️	F8-6833	⊕	
Engine Mounting	1.8 D, 1.8 TD, 1.8 Turbo D		F8-6952	⊕	
Mounting, axle beam	1.6 16V		F8-7935	🚗 ⊕ ⊕	
Control Arm-/Trailing Arm Bush	RS 2000, RS 2000 4x4, RS Cosworth 4x4		G9-501	🚗 ⊕ ⊕ ⊕	H=23; d=16; D1=49; D2=65
Control Arm-/Trailing Arm Bush	RS 2000, RS 2000 4x4, RS Cosworth 4x4		G9-501S	🚗 ⊕ ⊕ ⊕	H=23; d=16; D1=49; D2=65
Control Arm-/Trailing Arm Bush	RS 2000, RS 2000 4x4, RS Cosworth 4x4		G9-524	🚗 ⊕ ⊕ ⊕	H=52; d=12.1; D1=31.5; D2=40
Control Arm-/Trailing Arm Bush	1.3, 1.4, 1.6 16V, 1.6 16V 4x4, 1.6 i 16V, 1.8 16V, 1.8 D, 1.8 TD, 1.8 Turbo D, RS 2000, RS 2000 4x4, RS Cosworth 4x4		G9-585	🚗 ⊕ ⊕ ⊕	H1=46; H2=25; d=12; D=46
Control Arm-/Trailing Arm Bush	1.3, 1.4, 1.6 16V, 1.6 16V 4x4, 1.6 i 16V, 1.8 16V, 1.8 D, 1.8 TD, 1.8 Turbo D, RS 2000, RS 2000 4x4, RS Cosworth 4x4		G9-586	🚗 ⊕ ⊕ ⊕ ↓	H1=27; H2=46; d=12; D1=54; D2=62

**ESCORT Mk VII Convertible (ALL) 02/1995 → 08/2000**

Dust Cover Kit, shock absorber	All Models		AK-735017	🚗 ⊕ ⊕ ⊕	
Anti-Friction Bearing	All Models		F8-3019	🚗	H=14; d1=12; d2=20; D=45
Mounting, axle beam	All Models		F8-5329	🚗	H=70; d=12; D=64
Top Strut Mounting	1.4, 1.6 16V XR3i, 1.8 16V XR3i, 1.8 Turbo D		F8-5406	🚗 ⊕ ⊕ ⊕	
Top Strut Mounting	1.8 TD	⚙️	F8-5406	🚗 ⊕ ⊕ ⊕	
Top Strut Mounting	All Models	⚙️	F8-5447	🚗 ⊕ ⊕ ⊕	
Top Strut Mounting	All Models	⚙️	F8-5447S	🚗 ⊕ ⊕ ⊕	
Mounting, axle beam	All Models		F8-5971	🚗 ⊕ ⊕ ⊕	
Stabiliser Mounting	All Models		F8-6034	🚗 ⊕ ⊕ ⊕	d=16
Suspension Strut Mounting	All Models		F8-6356	🚗	
Engine Mounting	1.6 16V XR3i, 1.8 16V XR3i, 1.8 TD, 1.8 Turbo D		F8-6503	⊕	
Spring Cap	All Models		F8-6557	🚗	
Engine Mounting	1.6 16V XR3i, 1.8 16V XR3i, 1.8 TD, 1.8 Turbo D	Transmission Nr: B5, IB5; ⚙️	F8-6833	⊕	
Engine Mounting	1.8 16V XR3i	Transmission Nr: B5, IB5	F8-6833	⊕	
Engine Mounting	1.8 TD, 1.8 Turbo D		F8-6952	⊕	
Control Arm-/Trailing Arm Bush	All Models		G9-585	🚗 ⊕ ⊕ ⊕	H1=46; H2=25; d=12; D=46

<b>AK-735017</b>	<b>F8-3019</b>	<b>F8-5329</b>	<b>F8-5406</b>	<b>F8-5447</b>	<b>F8-5447S</b>	<b>F8-5971</b>
Ref.Nr.: 7102392	Ref.Nr.: 7331751	Ref.Nr.: 1E00-28-460B	Ref.Nr.: 7234730	Ref.Nr.: 7350847	Ref.Nr.: 7331751	Ref.Nr.: AB5K653AC
<b>F8-6034</b>	<b>F8-6356</b>	<b>F8-6503</b>	<b>F8-6557</b>	<b>F8-6833</b>	<b>F8-6952</b>	<b>F8-7935</b>
Ref.Nr.: 7102392	Ref.Nr.: 89FB-5599-AC	Ref.Nr.: 1 040 404	Ref.Nr.: 7350848	Ref.Nr.: 91AB6L028CB	Ref.Nr.: 6185027	Ref.Nr.: 6745350
<b>G9-501</b>	<b>G9-501S</b>	<b>G9-524</b>	<b>G9-585</b>	<b>G9-586</b>		
Ref.Nr.: 5021729	Ref.Nr.: 6122507	Ref.Nr.: 1632679	Ref.Nr.: 1000445	Ref.Nr.: 1035929		

**Article Description****Article Nr.****Fitting Position**

<b>ESCORT Mk VII Convertible (ALL)</b>			<b>02/1995 → 08/2000</b>		
Control Arm-/Trailing Arm Bush	All Models		<b>G9-586</b>		H1=27; H2=46; d=12; D1=54; D2=62
<b>ESCORT Mk VII Saloon (GAL, AFL)</b>			<b>01/1995 → 02/1999</b>		
Dust Cover Kit, shock absorber	All Models		<b>AK-735017</b>		
Dust Cover Kit, shock absorber	All Models		<b>AK-735082</b>		
Anti-Friction Bearing	All Models		<b>F8-3019</b>		H=14; d1=12; d2=20; D=45
Mounting, axle beam	All Models		<b>F8-5329</b>		H=70; d=12; D=64
Top Strut Mounting	1.3, 1.4, 1.6 i 16V, 1.8 16V, 1.8 D, 1.8 Turbo D		<b>F8-5406</b>		
Top Strut Mounting	1.8 TD		<b>F8-5406</b>		
Top Strut Mounting	All Models		<b>F8-5447</b>		
Top Strut Mounting	All Models		<b>F8-5447S</b>		
Engine Mounting	1.8 D		<b>F8-5561</b>		
Mounting, axle beam	All Models		<b>F8-5971</b>		
Stabiliser Mounting	All Models		<b>F8-6034</b>		d=16
Suspension Strut Mounting	All Models		<b>F8-6356</b>		
Engine Mounting	1.6 i 16V, 1.8 16V, 1.8 D, 1.8 TD, 1.8 Turbo D		<b>F8-6503</b>		
Spring Cap	All Models		<b>F8-6557</b>		
Engine Mounting	1.6 i 16V, 1.8 16V, 1.8 TD, 1.8 Turbo D	Transmission Nr.: B5, IB5;	<b>F8-6833</b>		
Engine Mounting	1.8 D	Transmission Nr.: B5, IB5	<b>F8-6833</b>		
Engine Mounting	1.8 D, 1.8 TD, 1.8 Turbo D		<b>F8-6952</b>		
Control Arm-/Trailing Arm Bush	All Models		<b>G9-585</b>		H1=46; H2=25; d=12; D=46
Control Arm-/Trailing Arm Bush	All Models		<b>G9-586</b>		H1=27; H2=46; d=12; D1=54; D2=62
<b>ESCORT Mk VII Estate (GAL, ANL)</b>			<b>01/1995 → 02/1999</b>		
Dust Cover Kit, shock absorber	All Models		<b>AK-735017</b>		
Anti-Friction Bearing	All Models		<b>F8-3019</b>		H=14; d1=12; d2=20; D=45
Mounting, axle beam	All Models		<b>F8-5329</b>		H=70; d=12; D=64
Top Strut Mounting	1.3, 1.4, 1.6 16V, 1.8 16V, 1.8 D, 1.8 Turbo D		<b>F8-5406</b>		
Top Strut Mounting	1.8 TD		<b>F8-5406</b>		
Top Strut Mounting	All Models		<b>F8-5447</b>		
Top Strut Mounting	All Models		<b>F8-5447S</b>		
Mounting, axle beam	All Models		<b>F8-5971</b>		
Stabiliser Mounting	All Models		<b>F8-6034</b>		d=16
Engine Mounting	1.6 16V, 1.6 i 16V, 1.8 16V, 1.8 D, 1.8 TD, 1.8 Turbo D		<b>F8-6503</b>		
Spring Cap	All Models		<b>F8-6557</b>		

<b>AK-735017</b>	<b>AK-735082</b>	<b>F8-3019</b>	<b>F8-5329</b>	<b>F8-5406</b>	<b>F8-5447</b>	<b>F8-5447S</b>
Ref.Nr.:	Ref.Nr.:	Ref.Nr.: 7331751	Ref.Nr.: 1E00-28-460B	Ref.Nr.: 7234730	Ref.Nr.: 7350847	Ref.Nr.: 7331751
<b>F8-5561</b>	<b>F8-5971</b>	<b>F8-6034</b>	<b>F8-6356</b>	<b>F8-6503</b>	<b>F8-6557</b>	<b>F8-6833</b>
Ref.Nr.: 6 160 229	Ref.Nr.: AB5K653AC	Ref.Nr.: 7102392	Ref.Nr.: 89FB-5599-AC	Ref.Nr.: 1 040 404	Ref.Nr.: 7350848	Ref.Nr.: 91AB6L028CB
<b>F8-6952</b>	<b>G9-585</b>	<b>G9-586</b>				
Ref.Nr.: 6185027	Ref.Nr.: 1000445	Ref.Nr.: 1035929				

Article Description



Article Nr.

Fitting Position



### ESCORT Mk VII Estate (GAL, ANL)

01/1995 → 02/1999

Engine Mounting	1.6 16V, 1.6 i 16V, 1.8 16V, 1.8 TD, 1.8 Turbo D	Transmission Nr: B5, IB5;	F8-6833		
Engine Mounting	1.8 D	Transmission Nr: B5, IB5	F8-6833		
Engine Mounting	1.8 D, 1.8 TD, 1.8 Turbo D		F8-6952		
Mounting, axle beam	1.3, 1.4, 1.6 i 16V, 1.8 16V, 1.8 D, 1.8 TD		F8-7935		
Control Arm-/Trailing Arm Bush	All Models		G9-585		H1=46; H2=25; d=12; D=46
Control Arm-/Trailing Arm Bush	All Models		G9-586		H1=27; H2=46; d=12; D1=54; D2=62

### FIESTA (GFBT)

05/1976 → 08/1983

Dust Cover Kit, shock absorber	0.9, 1.1, 1.3		AK-735005		
Dust Cover Kit, shock absorber	0.9, 1.1, 1.3, 1.6 XR2		AK-735097		
Mounting, manual transmission	0.9, 1.1, 1.3, 1.6 XR2		F8-5562		
Control Arm-/Trailing Arm Bush	0.9, 1.1, 1.3, 1.6 XR2		G9-522		H=51; d=10; D1=33; D2=38

### FIESTA Box (WFVT)

10/1977 → 11/1986

Dust Cover Kit, shock absorber	All Models		AK-735005		
Dust Cover Kit, shock absorber	All Models		AK-735097		
Top Strut Mounting	All Models		F8-5507		
Mounting, manual transmission	All Models		F8-5562		
Control Arm-/Trailing Arm Bush	All Models	09/1983 →	G9-522		H=51; d=10; D1=33; D2=38

### FIESTA Mk II (FBD)

09/1983 → 11/1989

Dust Cover Kit, shock absorber	1.0, 1.1, 1.3, 1.4, 1.6 D, 1.6 XR2		AK-735005		
Dust Cover Kit, shock absorber	1.0, 1.1, 1.3, 1.4, 1.6 D, 1.6 XR2		AK-735097		
Anti-Friction Bearing	1.0, 1.1, 1.3, 1.4, 1.6 D, 1.6 XR2		F8-3018		H=11; d1=12; d2=20; D=42.2
Anti-Friction Bearing	1.0, 1.1, 1.3, 1.6 XR2	12/1984 →	F8-3020		d=12; d1=12; d2=20; D=54; W=10
Anti-Friction Bearing	1.1, 1.4, 1.6 D, 1.6 XR2		F8-3020		d=12; d1=12; d2=20; D=54; W=10
Anti-Friction Bearing	1.0, 1.1, 1.3, 1.4, 1.6 D, 1.6 XR2		F8-3027		H=27; d=12; D1=95; D2=130
Bellow, steering	1.0, 1.1, 1.3, 1.4, 1.6 D, 1.6 XR2		F8-5038		
Top Strut Mounting	1.0, 1.1, 1.3, 1.4, 1.6 D, 1.6 XR2		F8-5507		
Mounting, manual transmission	1.0, 1.1, 1.3, 1.4, 1.6 D, 1.6 XR2		F8-5562		
Top Strut Mounting	1.0, 1.1, 1.3, 1.4	12/1984 →;	F8-5880		
Top Strut Mounting	1.1, 1.4	02/1987 →;	F8-5880		
Top Strut Mounting	1.4		F8-5880		
Top Strut Mounting	1.4, 1.6 D	01/1985 →;	F8-5880		
Engine Mounting	1.1, 1.3		F8-6929		

<b>AK-735005</b>	<b>AK-735097</b>	<b>F8-3018</b>	<b>F8-3020</b>	<b>F8-3027</b>	<b>F8-5038</b>	<b>F8-5507</b>
Ref.Nr.:	Ref.Nr.:	Ref.Nr.: 6112404	Ref.Nr.: 85BB3K099AA	Ref.Nr.: 90170695	Ref.Nr.: 6127744	Ref.Nr.: 6119999
<b>F8-5562</b>	<b>F8-5880</b>	<b>F8-6833</b>	<b>F8-6929</b>	<b>F8-6952</b>	<b>F8-7935</b>	<b>G9-522</b>
Ref.Nr.: 6049904	Ref.Nr.: 6150276	Ref.Nr.: 91AB6L028CB	Ref.Nr.: 84FB6038AE	Ref.Nr.: 6185027	Ref.Nr.: 6745350	Ref.Nr.: 1619120
<b>G9-585</b>	<b>G9-586</b>					
Ref.Nr.: 1000445	Ref.Nr.: 1035929					

**Article Description****Article Nr.****Fitting Position**

<b>FIESTA Mk II (FBD)</b>		<b>09/1983 → 11/1989</b>	
Control Arm-/Trailing Arm Bush	1.0 , 1.1 , 1.3 , 1.4 , 1.6 D , 1.6 XR2	<b>G9-522</b>	H=51; d=10; D1=33; D2=38
<b>FIESTA Box (FVD)</b>		<b>08/1983 → 12/1995</b>	
Dust Cover Kit, shock absorber	1.0, 1.8 D	<b>AK-735005</b>	
Dust Cover Kit, shock absorber	1.0, 1.8 D	<b>AK-735017</b>	
Dust Cover Kit, shock absorber	1.0	<b>AK-735097</b>	
Anti-Friction Bearing	1.0	<b>F8-3018</b>	H=11; d1=12; d2=20; D=42.2
Top Strut Mounting	1.8 D	<b>F8-5412</b>	
Top Strut Mounting	1.0, 1.8 D	<b>F8-5507</b>	
Stabiliser Mounting	1.8 D	<b>F8-6034</b>	d=16
Mounting, axle beam	1.8 D	<b>F8-6079</b>	H1=73; H2=37; d=32; D1=72; D2=40
Top Strut Mounting	1.8 D	<b>F8-6312</b>	08/1995 →;
Engine Mounting	1.8 D	<b>F8-6492</b>	
Engine Mounting	1.8 D	<b>F8-6952</b>	
Control Arm-/Trailing Arm Bush	1.8 D	<b>G9-585</b>	H1=46; H2=25; d=12; D=46
Control Arm-/Trailing Arm Bush	1.8 D	<b>G9-586</b>	H1=27; H2=46; d=12; D1=54; D2=62
Control Arm-/Trailing Arm Bush	1.8 D	<b>G9-662</b>	H1=44; H2=62; d=12; D1=24; D2=37
Control Arm-/Trailing Arm Bush	1.8 D	<b>G9-663</b>	H=50; d=12; D=66
<b>FIESTA Mk III (GFJ)</b>		<b>01/1989 → 01/1997</b>	
Dust Cover Kit, shock absorber	1.0, 1.1, 1.3, 1.3 CAT, 1.4, 1.4 CAT, 1.6, 1.6 i 16V, 1.6 Turbo , 1.6 XR2i, 1.8 16V, 1.8 D, 1.8 XR2i 16V	<b>AK-735017</b>	
Dust Cover Kit, shock absorber	1.0, 1.1, 1.3, 1.3 CAT, 1.4, 1.4 CAT, 1.6, 1.6 i 16V, 1.6 Turbo , 1.6 XR2i, 1.8 16V, 1.8 D, 1.8 TD, 1.8 XR2i 16V	<b>AK-735051</b>	
Dust Cover Kit, shock absorber	1.0, 1.1, 1.3, 1.3 CAT, 1.4, 1.4 CAT, 1.6, 1.6 i 16V, 1.8 D	<b>AK-735097</b>	
Anti-Friction Bearing	1.0, 1.1, 1.3, 1.3 CAT, 1.4, 1.4 CAT, 1.6, 1.6 i 16V, 1.6 XR2i, 1.8 16V, 1.8 D, 1.8 XR2i 16V	<b>F8-3018</b>	H=11; d1=12; d2=20; D=42.2
Anti-Friction Bearing	1.0, 1.1, 1.3, 1.3 CAT, 1.4, 1.4 CAT, 1.6, 1.6 i 16V, 1.6 Turbo , 1.6 XR2i, 1.8 16V, 1.8 D, 1.8 XR2i 16V	<b>F8-3020</b>	d=12; d1=12; d2=20; D=54; W=10
Anti-Friction Bearing	1.0, 1.1, 1.3, 1.3 CAT, 1.4, 1.4 CAT, 1.6, 1.6 i 16V, 1.6 XR2i, 1.8 16V, 1.8 D, 1.8 XR2i 16V	<b>F8-3027</b>	H=27; d=12; D1=95; D2=130
Top Strut Mounting	1.0, 1.1, 1.3, 1.3 CAT, 1.4, 1.4 CAT, 1.6, 1.6 i 16V, 1.6 Turbo , 1.6 XR2i, 1.8 16V, 1.8 D, 1.8 TD, 1.8 XR2i 16V	<b>F8-5507</b>	
Mounting, automatic transmission	1.3, 1.8 D	<b>F8-5559</b>	

<b>AK-735005</b>	<b>AK-735017</b>	<b>AK-735051</b>	<b>AK-735097</b>	<b>F8-3018</b>	<b>F8-3020</b>	<b>F8-3027</b>
Ref.Nr.:	Ref.Nr.:	Ref.Nr.:	Ref.Nr.:	Ref.Nr.: 6112404	Ref.Nr.: 85BB3K099AA	Ref.Nr.: 90170695
<b>F8-5412</b>	<b>F8-5507</b>	<b>F8-5559</b>	<b>F8-6034</b>	<b>F8-6079</b>	<b>F8-6312</b>	<b>F8-6492</b>
Ref.Nr.: 1E0034390	Ref.Nr.: 6119999	Ref.Nr.: 6161628	Ref.Nr.: 7102392	Ref.Nr.: 95FB-5C485-AA	Ref.Nr.: 1E003438X	Ref.Nr.: 1 661 786
<b>F8-6952</b>	<b>G9-522</b>	<b>G9-585</b>	<b>G9-586</b>	<b>G9-662</b>	<b>G9-663</b>	
Ref.Nr.: 6185027	Ref.Nr.: 1619120	Ref.Nr.: 1000445	Ref.Nr.: 1035929	Ref.Nr.: 1E0034153A	Ref.Nr.: 1063372	

Article Description



Article Nr.

Fitting Position



### FIESTA Mk III (GFJ)

01/1989 → 01/1997

Mounting, automatic transmission	1.4, 1.4 CAT, 1.6, 1.6 XR2i		F8-5559		
Mounting, manual transmission	1.0, 1.1, 1.3, 1.3 CAT, 1.4, 1.4 CAT, 1.6, 1.6 Turbo, 1.6 XR2i		F8-5562		
Top Strut Mounting	1.0, 1.1, 1.3, 1.3 CAT, 1.4, 1.4 CAT, 1.6, 1.6 i 16V, 1.6 Turbo, 1.6 XR2i, 1.8 16V, 1.8 D, 1.8 XR2i 16V		F8-5880		
Stabiliser Mounting	1.0, 1.1, 1.3, 1.3 CAT, 1.4, 1.4 CAT, 1.6, 1.6 i 16V, 1.6 Turbo, 1.6 XR2i, 1.8 16V, 1.8 D, 1.8 TD, 1.8 XR2i 16V		F8-6034		d=16
Suspension Strut Mounting	1.0, 1.1, 1.3, 1.3 CAT, 1.4, 1.4 CAT, 1.6, 1.6 i 16V, 1.6 Turbo, 1.6 XR2i, 1.8 16V, 1.8 D, 1.8 TD, 1.8 XR2i 16V		F8-6260		
Suspension Strut Mounting	1.0, 1.1, 1.3, 1.3 CAT, 1.4, 1.4 CAT, 1.6, 1.6 i 16V, 1.6 Turbo, 1.6 XR2i, 1.8 16V, 1.8 D, 1.8 TD, 1.8 XR2i 16V		F8-6356		
Engine Mounting	1.0, 1.1, 1.3, 1.3 CAT, 1.8 D		F8-6492		
Engine Mounting	1.4, 1.6, 1.6 XR2i		F8-6492		
Engine Mounting	1.0, 1.1, 1.3, 1.4, 1.4 CAT, 1.6, 1.6 Turbo, 1.6 XR2i, 1.8 D		F8-6506		
Engine Mounting	1.0, 1.1, 1.3, 1.4, 1.4 CAT, 1.6, 1.6 Turbo, 1.6 XR2i, 1.8 D		F8-6506		
Engine Mounting	1.3 CAT		F8-6506		
Engine Mounting	1.4	08/1988 →	F8-6506		
Engine Mounting	1.1, 1.3, 1.3 CAT		F8-6930		
Engine Mounting	1.8 D		F8-6952		
Engine Mounting	1.8 TD		F8-6952		
Mounting, axle beam	All Models		F8-7935		
Control Arm-/Trailing Arm Bush	1.0, 1.1, 1.3, 1.3 CAT, 1.4, 1.4 CAT, 1.6, 1.6 i 16V, 1.6 Turbo, 1.6 XR2i, 1.8 16V, 1.8 D, 1.8 TD, 1.8 XR2i 16V		G9-585		H1=46; H2=25; d=12; D=46
Control Arm-/Trailing Arm Bush	1.0, 1.1, 1.3, 1.3 CAT, 1.4, 1.4 CAT, 1.6, 1.6 i 16V, 1.6 Turbo, 1.6 XR2i, 1.8 16V, 1.8 D, 1.8 TD, 1.8 XR2i 16V		G9-586		H1=27; H2=46; d=12; D1=54; D2=62
Bellow, steering	1.0, 1.1, 1.3 CAT, 1.4, 1.4 CAT, 1.6, 1.6 XR2i, 1.8 16V, 1.8 D, 1.8 TD, 1.8 XR2i 16V	01/1994 →; with clamps;	LM-10007S		d1=14; d2=56; L [mm]=175
Bellow, steering	1.6 i 16V	with clamps;	LM-10007S		d1=14; d2=56; L [mm]=175

### COURIER Box (F3L, F5L)

09/1991 → 02/1996

Dust Cover Kit, shock absorber	All Models		AK-735017		
Dust Cover Kit, shock absorber	All Models		AK-735051		
Dust Cover Kit, shock absorber	All Models		AK-735097		
Anti-Friction Bearing	All Models		F8-3020		d=12; d1=12; d2=20; D=54; W=10
Top Strut Mounting	All Models		F8-5412		
Top Strut Mounting	All Models		F8-5507		
Mounting, manual transmission	1.3		F8-5562		
Stabiliser Mounting	All Models		F8-6034		d=16

AK-735017	AK-735051	AK-735097	F8-3020	F8-5412	F8-5507	F8-5559
Ref.Nr.:	Ref.Nr.:	Ref.Nr.:	Ref.Nr.: 85BB3K099AA	Ref.Nr.: 1E0034390	Ref.Nr.: 6119999	Ref.Nr.: 6161628
F8-5562	F8-5880	F8-6034	F8-6079	F8-6260	F8-6356	F8-6492
Ref.Nr.: 6049904	Ref.Nr.: 6150276	Ref.Nr.: 7102392	Ref.Nr.: 95FB-5C485-AA	Ref.Nr.: 89FB-5599-ACS	Ref.Nr.: 89FB-5599-AC	Ref.Nr.: 1 661 786
F8-6506	F8-6930	F8-6952	F8-7935	G9-585	G9-586	LM-10007S
Ref.Nr.: 6203710	Ref.Nr.: 6161627	Ref.Nr.: 6185027	Ref.Nr.: 6745350	Ref.Nr.: 1000445	Ref.Nr.: 1035929	Ref.Nr.: 94FB-3K661-AC



**Article Description****Article Nr.****Fitting Position**

<b>COURIER Box (F3L, F5L)</b>				<b>09/1991 → 02/1996</b>	
Mounting, axle beam	All Models		<b>F8-6079</b>		H1=73; H2=37; d=32; D1=72; D2=40
Top Strut Mounting	All Models	08/1995 →;	<b>F8-6312</b>		
Suspension Strut Mounting	All Models		<b>F8-6356</b>		
Engine Mounting	All Models		<b>F8-6492</b>		
Engine Mounting	1.3		<b>F8-6506</b>		
Engine Mounting	1.8 D		<b>F8-6952</b>		
Mounting, axle beam	All Models		<b>F8-7935</b>		
Control Arm-/Trailing Arm Bush	All Models		<b>G9-585</b>		H1=46; H2=25; d=12; D=46
Control Arm-/Trailing Arm Bush	All Models		<b>G9-586</b>		H1=27; H2=46; d=12; D1=54; D2=62
Control Arm-/Trailing Arm Bush	All Models	01/1994 →	<b>G9-662</b>		H1=44; H2=62; d=12; D1=24; D2=37
Control Arm-/Trailing Arm Bush	All Models	01/1994 →	<b>G9-663</b>		H=50; d=12; D=66
<b>FIESTA Mk IV (JA_, JB_)</b>				<b>08/1995 → 01/2002</b>	
Dust Cover Kit, shock absorber	1.0 i, 1.25 i 16V, 1.3 i, 1.4 i 16V, 1.8 D, 1.8 DI		<b>AK-735017</b>		
Dust Cover Kit, shock absorber	1.0 i, 1.25 i 16V, 1.3 i, 1.4 i 16V, 1.8 D, 1.8 DI		<b>AK-735082</b>		
Stabiliser Mounting	1.0 i		<b>F8-5328</b>		d=15
Stabiliser Mounting	1.25 i 16V, 1.3 i, 1.4 i 16V, 1.6 16V Sport, 1.8 D, 1.8 DI	for OE: 1003609	<b>F8-5328</b>		D=15; d=15
Mounting, axle beam	1.0 i, 1.1, 1.25 i 16V, 1.3 i, 1.4 i 16V, 1.6 16V Sport, 1.8 D, 1.8 DI		<b>F8-5329</b>		H=70; d=12; D=64
Top Strut Mounting	1.25 i 16V, 1.3 i, 1.4 i 16V, 1.8 D, 1.8 DI	02/2000 →; ; ;	<b>F8-5409</b>		d=22; D1=99; D2=106
Top Strut Mounting	1.6 16V Sport	;	<b>F8-5409</b>		d=22; D1=99; D2=106
Top Strut Mounting	1.0 i, 1.4 i 16V, 1.6 16V Sport, 1.8 DI		<b>F8-5410</b>		
Top Strut Mounting	1.25 i 16V, 1.3 i, 1.8 D	01/1996 →	<b>F8-5410</b>		
Engine Mounting	1.25 i 16V, 1.3 i, 1.4 i 16V, 1.6 16V Sport, 1.8 D, 1.8 DI		<b>F8-5411</b>		
Top Strut Mounting	1.0 i, 1.1, 1.4 i 16V		<b>F8-5412</b>		
Top Strut Mounting	1.25 i 16V, 1.3 i, 1.8 D	;	<b>F8-5412</b>		
Top Strut Mounting	1.6 16V Sport, 1.8 DI	;	<b>F8-5412</b>		
Anti-Friction Bearing	1.25 i 16V, 1.3 i, 1.4 i 16V, 1.6 16V Sport, 1.8 D, 1.8 DI		<b>F8-5413</b>		
Stabiliser Mounting	1.0 i, 1.25 i 16V, 1.3 i, 1.4 i 16V, 1.6 16V Sport, 1.8 D, 1.8 DI		<b>F8-6034</b>		d=16
Mounting, axle beam	1.0 i, 1.1, 1.25 i 16V, 1.3 i, 1.4 i 16V, 1.6 16V Sport, 1.8 D, 1.8 DI		<b>F8-6074</b>		H1=70; H2=55; D=63.2
Mounting, axle beam	1.8 D, 1.8 DI		<b>F8-6079</b>		H1=73; H2=37; d=32; D1=72; D2=40

<b>AK-735017</b>	<b>AK-735082</b>	<b>F8-5328</b>	<b>F8-5329</b>	<b>F8-5409</b>	<b>F8-5410</b>	<b>F8-5411</b>
Ref.Nr.:	Ref.Nr.:	Ref.Nr.: 96FB5484CA	Ref.Nr.: 1E00-28-460B	Ref.Nr.: 1039001	Ref.Nr.: 1E0028012A	Ref.Nr.: 1014899
<b>F8-5412</b>	<b>F8-5413</b>	<b>F8-6034</b>	<b>F8-6074</b>	<b>F8-6079</b>	<b>F8-6312</b>	<b>F8-6356</b>
Ref.Nr.: 1E0034390	Ref.Nr.: 1002513	Ref.Nr.: 7102392	Ref.Nr.: 1016439	Ref.Nr.: 95FB-5C485-AA	Ref.Nr.: 1E003438X	Ref.Nr.: 89FB-5599-AC
<b>F8-6492</b>	<b>F8-6506</b>	<b>F8-6952</b>	<b>F8-7935</b>	<b>G9-585</b>	<b>G9-586</b>	<b>G9-662</b>
Ref.Nr.: 1 661 786	Ref.Nr.: 6203710	Ref.Nr.: 6185027	Ref.Nr.: 6745350	Ref.Nr.: 1000445	Ref.Nr.: 1035929	Ref.Nr.: 1E0034153A

Article Description



Article Nr.

Fitting Position



<b>FIESTA Mk IV (JA_, JB_) 08/1995 → 01/2002</b>	
Top Strut Mounting	1.0 i, 1.25 i 16V, 1.3 i, 1.4 i 16V, 1.6 16V Sport, 1.8 D, 1.8 DI
Belt Pulley, crankshaft	1.8 DI
Locking ring	1.25 i 16V, 1.3 i, 1.4 i 16V, 1.6 16V Sport, 1.8 D, 1.8 DI
Spring Cap	1.0 i, 1.1, 1.25 i 16V, 1.3 i, 1.4 i 16V, 1.6 16V Sport, 1.8 D, 1.8 DI
Top Strut Mounting	1.25 i 16V, 1.3 i, 1.4 i 16V, 1.6 16V Sport
Engine Mounting	1.8 D, 1.8 DI
Engine Mounting	1.8 D
Engine Mounting	1.0 i, 1.25 i 16V, 1.3 i, 1.4 i 16V, 1.6 16V Sport
Control Arm-/Trailing Arm Bush	1.0 i, 1.25 i 16V, 1.3 i, 1.4 i 16V, 1.6 16V Sport, 1.8 D, 1.8 DI
Control Arm-/Trailing Arm Bush	1.0 i, 1.25 i 16V, 1.3 i, 1.4 i 16V, 1.6 16V Sport, 1.8 D, 1.8 DI
Bellow, steering	1.25 i 16V, 1.3 i, 1.4 i 16V, 1.8 D
<b>COURIER Box (J5_, J3_) 02/1996 → 08/2003</b>	
Dust Cover Kit, shock absorber	All Models
Dust Cover Kit, shock absorber	1.8 D
Anti-Friction Bearing	1.8 D
Stabiliser Mounting	1.3, 1.4 i, 1.8 D
Stabiliser Mounting	1.8 DI
Mounting, axle beam	All Models
Top Strut Mounting	All Models
Engine Mounting	1.3, 1.8 D, 1.8 DI
Top Strut Mounting	All Models
Anti-Friction Bearing	All Models
Top Strut Mounting	1.8 D
Stabiliser Mounting	All Models
Mounting, axle beam	All Models
Mounting, axle beam	All Models
Top Strut Mounting	All Models
Engine Mounting	1.8 D
Engine Mounting	1.8 D
Engine Mounting	1.3, 1.4 i
Control Arm-/Trailing Arm Bush	All Models

<b>AK-735017</b>	<b>AK-735051</b>	<b>F8-3020</b>	<b>F8-5328</b>	<b>F8-5329</b>	<b>F8-5410</b>	<b>F8-5411</b>
Ref.Nr.:	Ref.Nr.:	Ref.Nr.: 85BB3K099AA	Ref.Nr.: 96FB5484CA	Ref.Nr.: 1E00-28-460B	Ref.Nr.: 1E0028012A	Ref.Nr.: 1014899
<b>F8-5412</b>	<b>F8-5413</b>	<b>F8-5507</b>	<b>F8-6034</b>	<b>F8-6074</b>	<b>F8-6079</b>	<b>F8-6312</b>
Ref.Nr.: 1E0034390	Ref.Nr.: 1002513	Ref.Nr.: 6119999	Ref.Nr.: 7102392	Ref.Nr.: 1016439	Ref.Nr.: 95FB-5C485-AA	Ref.Nr.: 1E003438X
<b>F8-6387</b>	<b>F8-6556</b>	<b>F8-6557</b>	<b>F8-6559</b>	<b>F8-6926</b>	<b>F8-6952</b>	<b>F8-8115</b>
Ref.Nr.: 1 079 188	Ref.Nr.: 1010127	Ref.Nr.: 7350848	Ref.Nr.: 1150967	Ref.Nr.: 1021268	Ref.Nr.: 6185027	Ref.Nr.: 1021267

**Article Description****Article Nr.****Fitting Position**

<b>COURIER Box (J5, J3)</b>				<b>02/1996 → 08/2003</b>	
Control Arm-/Trailing Arm Bush	All Models		<b>G9-663</b>	⊕ ⊕	H=50; d=12; D=66
<b>COURIER Box (JV)</b>				<b>05/1998 → 08/2003</b>	
Dust Cover Kit, shock absorber	All Models		<b>AK-735017</b>	⊕ ⊕	
Stabiliser Mounting	D 1.8		<b>F8-5328</b>		d=15
Mounting, axle beam	All Models	<b>HD</b>	<b>F8-5329</b>		H=70; d=12; D=64
Top Strut Mounting	All Models		<b>F8-5410</b>	⊕ ⊕	
Engine Mounting	All Models		<b>F8-5411</b>		
Top Strut Mounting	All Models		<b>F8-5412</b>	⊕ ⊕	
Anti-Friction Bearing	All Models		<b>F8-5413</b>	⊕ ⊕	
Stabiliser Mounting	All Models		<b>F8-6034</b>	⊕ ⊕	d=16
Mounting, axle beam	All Models	<b>HD</b>	<b>F8-6074</b>	⊕ ⊕	H1=70; H2=55; D=63.2
Mounting, axle beam	All Models		<b>F8-6079</b>	⊕ ⊕	H1=73; H2=37; d=32; D1=72; D2=40
Top Strut Mounting	D 1.8		<b>F8-6312</b>	⊕ ⊕	
Engine Mounting	D 1.8		<b>F8-6926</b>	⊕	
Control Arm-/Trailing Arm Bush	All Models		<b>G9-662</b>	⊕ ⊕	H1=44; H2=62; d=12; D1=24; D2=37
Control Arm-/Trailing Arm Bush	All Models		<b>G9-663</b>	⊕ ⊕	H=50; d=12; D=66
<b>FIESTA V (JH, JD)</b>				<b>11/2001 → 06/2008</b>	
Dust Cover Kit, shock absorber	1.25 16V, 1.3, 1.4 16V, 1.4 TDCi, 1.6 16V, 1.6 TDCi	<b>ST</b>	<b>AK-735095</b>	⊕ ⊕	
Dust Cover Kit, shock absorber	1.25 16V, 1.3, 1.4 16V, 1.4 TDCi, 1.6 16V, 1.6 TDCi	<b>ST</b>	<b>AK-735431</b>		
Alternator Freewheel Clutch	1.4 TDCi		<b>F5-1052</b>		
Stabiliser Mounting	1.25 16V, 1.3, 1.4 16V, 1.4 TDCi, 1.6 16V		<b>F8-5328</b>		d=15
Control Arm-/Trailing Arm Bush	1.25 16V, 1.3, 1.4 16V, 1.4 TDCi, 1.6 16V, 1.6 TDCi, ST150		<b>F8-6159</b>	⊕ ⊕ ⊕ ↓	
Control Arm-/Trailing Arm Bush	1.25 16V, 1.3, 1.4 16V, 1.4 TDCi, 1.6 16V, 1.6 TDCi, ST150		<b>F8-6160</b>	⊕ ⊕ ⊕ ↓	
Anti-Friction Bearing	1.25 16V, 1.3, 1.4 16V, 1.4 TDCi, 1.6 16V, 1.6 TDCi, ST150		<b>F8-6317</b>		
Top Strut Mounting	All Models		<b>F8-6358</b>		
Belt Pulley, crankshaft	1.6 TDCi	Number of Ribs: 6	<b>F8-7082</b>		Belt Pulley Ø [mm]=152; Mounting points diam.[mm]=30; W=34
Top Strut Mounting	All Models		<b>F8-7431</b>	⊕ ⊕	
Rubber Buffer, suspension	1.25 16V, 1.3, 1.4 16V, 1.4 TDCi, 1.6 16V, 1.6 TDCi, ST150	<b>ST</b>	<b>F8-7581</b>	⊕ ⊕	H=86

<b>AK-735017</b>	<b>AK-735095</b>	<b>AK-735431</b>	<b>F5-1052</b>	<b>F8-5328</b>	<b>F8-5329</b>	<b>F8-5410</b>
Ref.Nr.:	Ref.Nr.: 1J0512131B	Ref.Nr.: 1254213	Ref.Nr.:	Ref.Nr.: 96FB5484CA	Ref.Nr.: 1E00-28-460B	Ref.Nr.: 1E0028012A
<b>F8-5411</b>	<b>F8-5412</b>	<b>F8-5413</b>	<b>F8-6034</b>	<b>F8-6074</b>	<b>F8-6079</b>	<b>F8-6159</b>
Ref.Nr.: 1014899	Ref.Nr.: 1E0034390	Ref.Nr.: 1002513	Ref.Nr.: 7102392	Ref.Nr.: 1016439	Ref.Nr.: 95FB-5C485-AA	Ref.Nr.: 1212807-PART
<b>F8-6160</b>	<b>F8-6312</b>	<b>F8-6317</b>	<b>F8-6358</b>	<b>F8-6926</b>	<b>F8-7082</b>	<b>F8-7431</b>
Ref.Nr.: 1212807-PART	Ref.Nr.: 1E003438X	Ref.Nr.: 1146152	Ref.Nr.: 1330706	Ref.Nr.: 1021268	Ref.Nr.: 0515.R0	Ref.Nr.: 1469224

Article Description



Article Nr.

Fitting Position



<b>FIESTA V (JH_, JD_)</b>			11/2001 → 06/2008		
Protective Cap/Bellow, shock absorber	1.25 16V, 1.3, 1.4 16V, 1.4 TDCi, 1.6 16V, 1.6 TDCi, ST150		F8-7683		
Stabiliser Mounting	All Models		F8-7934		d=17
Control Arm-/Trailing Arm Bush	All Models		F8-8001		
Engine Mounting	All Models		F8-8139		
Repair Kit, suspension strut	All Models		F8-8213		
<b>FIESTA V Van</b>			10/2003 → 12/2010		
Alternator Freewheel Clutch	1.4 TDCi		F5-1052		
Top Strut Mounting	1.3, 1.4 TDCi		F8-6358		
Top Strut Mounting	1.3, 1.4 TDCi		F8-7431		
Rubber Buffer, suspension	1.3	ST	F8-7581		H=86
Stabiliser Mounting	1.3		F8-7934		d=17
Control Arm-/Trailing Arm Bush	1.3		F8-8001		
Engine Mounting	All Models		F8-8139		
Repair Kit, suspension strut	All Models		F8-8213		
<b>FIESTA VI</b>			06/2008 →		
Dust Cover Kit, shock absorber	1.25, 1.4, 1.4 LPG, 1.4 TDCi, 1.6 TDCi, 1.6 Ti		AK-735095		
Dust Cover Kit, shock absorber	1.25, 1.4, 1.4 LPG, 1.4 TDCi, 1.6, 1.6 TDCi, 1.6 Ti	ST	AK-735435		
Belt Pulley, crankshaft	1.6 TDCi	Number of Ribs: 6	F8-7082		Belt Pulley Ø [mm]=152; Mounting points diam.[mm]=30; W=34
Top Strut Mounting	1.25, 1.4, 1.4 LPG, 1.4 TDCi, 1.6, 1.6 TDCi, 1.6 Ti		F8-7432		
Anti-Friction Bearing	1.25, 1.4, 1.4 LPG, 1.4 TDCi, 1.6, 1.6 TDCi, 1.6 Ti		F8-7433		
Top Strut Mounting	1.25, 1.4, 1.4 LPG, 1.4 TDCi, 1.6, 1.6 TDCi, 1.6 Ti		F8-7434		H=48; d=8
Protective Cap/Bellow, shock absorber	1.0, 1.0 EcoBoost, 1.25, 1.4, 1.4 LPG, 1.4 TDCi, 1.5 TDCi, 1.6, 1.6 ST, 1.6 TDCi, 1.6 Ti		F8-7489		
Engine Mounting	1.25, 1.4, 1.4 LPG, 1.4 TDCi, 1.6, 1.6 TDCi, 1.6 Ti		F8-8139		
<b>FIESTA Saloon</b>			10/2012 →		
Protective Cap/Bellow, shock absorber	All Models		F8-7489		
<b>FIESTA VI Van</b>			01/2009 →		
Dust Cover Kit, shock absorber	1.25, 1.4 TDCi, 1.5 TDCi, 1.6 TDCi		AK-735095		
Top Strut Mounting	1.4 TDCi, 1.6 TDCi		F8-7432		
Anti-Friction Bearing	1.25, 1.4 TDCi, 1.6 TDCi		F8-7433		
Top Strut Mounting	1.4 TDCi, 1.6 TDCi		F8-7434		H=48; d=8

<b>AK-735095</b>	<b>AK-735435</b>	<b>F5-1052</b>	<b>F8-6358</b>	<b>F8-7082</b>	<b>F8-7431</b>	<b>F8-7432</b>
Ref.Nr.: 1J0512131B	Ref.Nr.: 1514543	Ref.Nr.:	Ref.Nr.: 1330706	Ref.Nr.: 0515.R0	Ref.Nr.: 1469224	Ref.Nr.: 1514834
<b>F8-7433</b>	<b>F8-7434</b>	<b>F8-7489</b>	<b>F8-7581</b>	<b>F8-7683</b>	<b>F8-7934</b>	<b>F8-8001</b>
Ref.Nr.: 1514857	Ref.Nr.: 1535299	Ref.Nr.: 8V51-5349-AB	Ref.Nr.: 1254220	Ref.Nr.: 1254213	Ref.Nr.: 1152852	Ref.Nr.: 1426699
<b>F8-8139</b>	<b>F8-8213</b>					
Ref.Nr.: 1695146	Ref.Nr.: 1151926					

**Article Description****Article Nr.****Fitting Position**

<b>FIESTA VI Van</b>		<b>01/2009 →</b>	
Engine Mounting	1.25, 1.4 TDCi, 1.6 TDCi	F8-8139	↓
<b>FOCUS (DAW, DBW)</b>		<b>10/1998 → 11/2004</b>	
Dust Cover Kit, shock absorber	1.4 16V, 1.6 16V, 1.8 16V, 1.8 DI / TDDi, 1.8 TDCi, 1.8 Turbo DI / TDDi, 2.0 16V	AK-735093	⊕ ⊕ ⊕
Dust Cover Kit, shock absorber	1.4 16V, 1.6 16V, 1.8 16V, 1.8 DI / TDDi, 1.8 TDCi, 1.8 Turbo DI / TDDi, 2.0 16V	AK-735128	⊕ ⊕ ⊕
Alternator Freewheel Clutch	1.8 TDCi	F5-1057	
Alternator Freewheel Clutch	ST170	F5-1094	
Stabiliser Mounting	1.4 16V, 1.6 16V, 1.8 16V, 1.8 DI / TDDi, 1.8 TDCi, 1.8 Turbo DI / TDDi, 2.0 16V, RS, ST170	F8-5330	⊕ ⊕ ⊕
Control Arm-/Trailing Arm Bush	1.4 16V, 1.6 16V, 1.8 16V, 1.8 DI / TDDi, 1.8 TDCi, 1.8 Turbo DI / TDDi, 2.0 16V, ST170	F8-6015	⊕ ⊕ ⊕ H=64.5; d=12.1; D=40
Control Arm-/Trailing Arm Bush	1.4 16V, 1.6 16V, 1.8 16V, 1.8 DI / TDDi, 1.8 Turbo DI / TDDi, 2.0 16V	F8-6016	⊕ ⊕ ⊕
Rubber Buffer, suspension	All Models	F8-6060	H=55
Rubber Buffer, suspension	1.4 16V, 1.6 16V, 1.8 16V, 1.8 DI / TDDi, 1.8 TDCi, 1.8 Turbo DI / TDDi, 2.0 16V, RS, ST170	F8-6061	⊕ ⊕ ⊕ H=115; d=32; D=55
Top Strut Mounting	All Models	F8-6066	⊕ ⊕ ⊕ Outer Thread [mm]=M8 x 1,5
Mounting, manual transmission	1.4 16V, 1.6 16V, 1.6 16V Flexifuel, 1.8 16V, 2.0 16V	F8-6208	
Engine Mounting	All Models	F8-6209	
Top Strut Mounting	1.4 16V, 1.6 16V, 1.6 16V Flexifuel, 1.8 16V, 1.8 DI / TDDi, 1.8 TDCi, 1.8 Turbo DI / TDDi, 2.0 16V	F8-6318	⊕ ⊕ ⊕
Supporting Ring, suspension strut bearing	1.4 16V, 1.6 16V, 1.8 16V, 1.8 DI / TDDi, 1.8 TDCi, 1.8 Turbo DI / TDDi, 2.0 16V	F8-6355	
Belt Pulley, crankshaft	1.8 DI / TDDi	F8-6387	Number of Ribs: 6 d=14; D=140
Belt Pulley, crankshaft	1.8 Turbo DI / TDDi	F8-6387	01/1999 →; Number of Ribs: 6 d=14; D=140
Belt Pulley, crankshaft	1.8 TDCi	F8-6399	Number of Ribs: 6
Engine Mounting	1.4 16V, 1.6 16V, 1.8 16V, 1.8 DI / TDDi, 1.8 TDCi, 1.8 Turbo DI / TDDi, 2.0 16V, RS, ST170	F8-6472	⊕
Engine Mounting	1.4 16V, 1.6 16V	F8-6475	⊕
Anti-Friction Bearing	All Models	F8-6511	d=68; D=98; Thick. [mm]=18.5
Spring Cap	1.4 16V, 1.6 16V, 1.8 16V, 1.8 DI / TDDi, 1.8 TDCi, 1.8 Turbo DI / TDDi, 2.0 16V, RS, ST170	F8-6555	
Mounting, axle beam	All Models	F8-6638	⊕ ⊕ ⊕ D=60
Stabiliser Mounting	1.4 16V, 1.6 16V, 1.8 16V, 1.8 DI / TDDi, 1.8 TDCi, 1.8 Turbo DI / TDDi, 2.0 16V, RS, ST170	F8-6732	⊕ ⊕ ⊕
Engine Mounting	2.0 16V	F8-6754	
Engine Mounting	ST170	F8-6754	6-speed
Engine Mounting	1.4 16V, 1.6 16V, 1.8 16V, 1.8 TDCi	F8-7030	

<b>AK-735093</b>	<b>AK-735128</b>	<b>F5-1057</b>	<b>F5-1094</b>	<b>F8-5330</b>	<b>F8-6015</b>	<b>F8-6016</b>
Ref.Nr.:	Ref.Nr.:	Ref.Nr.: 5M5Q-10344-AA	Ref.Nr.: VP6S4U10A352	Ref.Nr.: 1073217	Ref.Nr.: 98AG3063AE	Ref.Nr.: 1067918
<b>F8-6060</b>	<b>F8-6061</b>	<b>F8-6066</b>	<b>F8-6208</b>	<b>F8-6209</b>	<b>F8-6318</b>	<b>F8-6355</b>
Ref.Nr.: 1064069	Ref.Nr.: 1073486	Ref.Nr.: 1061722	Ref.Nr.: 1323096	Ref.Nr.: 3M51GP093	Ref.Nr.: 1115132	Ref.Nr.: 1061658
<b>F8-6387</b>	<b>F8-6399</b>	<b>F8-6472</b>	<b>F8-6475</b>	<b>F8-6511</b>	<b>F8-6555</b>	<b>F8-6638</b>
Ref.Nr.: 1 079 188	Ref.Nr.: 1151 392	Ref.Nr.: 1 133 019	Ref.Nr.: 98AB6038CH	Ref.Nr.: 1061721	Ref.Nr.: 1073155	Ref.Nr.: C2Y6-28-460

Article Description



Article Nr.

Fitting Position



<b>FOCUS (DAW, DBW)</b>		<b>10/1998 → 11/2004</b>	
Protective Cap/Bellow, shock absorber	1.4 16V, 1.6 16V, 1.8 16V, 1.8 DI / TDDi, 1.8 TDCi, 1.8 Turbo DI / TDDi, 2.0 16V, ST170	F8-7686	
Engine Mounting	1.6 16V, 1.8 16V, 2.0 16V	F8-8165	
<b>FOCUS Saloon (DFW)</b>		<b>02/1999 → 03/2005</b>	
Dust Cover Kit, shock absorber	1.4 16V, 1.6 16V, 1.8 16V, 1.8 TDCi, 1.8 Turbo DI / TDDi, 2.0 16V	AK-735093	
Dust Cover Kit, shock absorber	1.4 16V, 1.6 16V, 1.8 16V, 1.8 TDCi, 1.8 Turbo DI / TDDi, 2.0 16V	AK-735128	
Alternator Freewheel Clutch	1.8 TDCi	F5-1057	
Stabiliser Mounting	1.4 16V, 1.6 16V, 1.8 16V, 1.8 TDCi, 1.8 Turbo DI / TDDi, 2.0 16V	F8-5330	
Control Arm-/Trailing Arm Bush	1.4 16V, 1.6 16V, 1.8 16V, 1.8 TDCi, 1.8 Turbo DI / TDDi, 2.0 16V	F8-6015	
Rubber Buffer, suspension	All Models	F8-6060	
Rubber Buffer, suspension	All Models	F8-6061	
Top Strut Mounting	All Models	F8-6066	
Mounting, manual transmission	1.4 16V, 1.6 16V, 1.8 16V, 2.0 16V	F8-6208	
Engine Mounting	All Models	F8-6209	
Top Strut Mounting	All Models	F8-6318	
Supporting Ring, suspension strut bearing	1.4 16V, 1.6 16V, 1.8 16V, 1.8 TDCi, 1.8 Turbo DI / TDDi, 2.0 16V	F8-6355	
Belt Pulley, crankshaft	1.8 Turbo DI / TDDi	F8-6387	
Belt Pulley, crankshaft	1.8 TDCi	F8-6399	
Engine Mounting	1.4 16V, 1.6 16V, 1.8 16V, 1.8 TDCi, 1.8 Turbo DI / TDDi, 2.0 16V	F8-6472	
Engine Mounting	1.4 16V, 1.6 16V	F8-6475	
Anti-Friction Bearing	All Models	F8-6511	
Spring Cap	1.4 16V, 1.6 16V, 1.8 16V, 1.8 TDCi, 1.8 Turbo DI / TDDi, 2.0 16V	F8-6555	
Mounting, axle beam	All Models	F8-6638	
Stabiliser Mounting	1.4 16V, 1.6 16V, 1.8 16V, 1.8 TDCi, 1.8 Turbo DI / TDDi, 2.0 16V	F8-6732	
Engine Mounting	2.0 16V	F8-6754	
Engine Mounting	1.4 16V, 1.6 16V, 1.8 16V, 1.8 TDCi	F8-7030	
Protective Cap/Bellow, shock absorber	1.4 16V, 1.6 16V, 1.8 16V, 1.8 TDCi, 1.8 Turbo DI / TDDi, 2.0 16V	F8-7686	
Engine Mounting	1.6 16V, 1.8 16V, 2.0 16V	F8-8165	
<b>FOCUS Estate (DNW)</b>		<b>02/1999 → 01/2005</b>	
Dust Cover Kit, shock absorber	1.4 16V, 1.6 16V, 1.8 16V, 1.8 DI / TDDi, 1.8 TDCi, 1.8 Turbo DI / TDDi, 2.0 16V	AK-735093	

<b>AK-735093</b>	<b>AK-735128</b>	<b>F5-1057</b>	<b>F8-5330</b>	<b>F8-6015</b>	<b>F8-6060</b>	<b>F8-6061</b>
Ref.Nr.:	Ref.Nr.:	Ref.Nr.: 5M5Q-10344-AA	Ref.Nr.: 1073217	Ref.Nr.: 98AG3063AE	Ref.Nr.: 1064069	Ref.Nr.: 1073486
<b>F8-6066</b>	<b>F8-6208</b>	<b>F8-6209</b>	<b>F8-6318</b>	<b>F8-6355</b>	<b>F8-6387</b>	<b>F8-6399</b>
Ref.Nr.: 1061722	Ref.Nr.: 1323096	Ref.Nr.: 3M51GP093	Ref.Nr.: 1115132	Ref.Nr.: 1061658	Ref.Nr.: 1 079 188	Ref.Nr.: 1151 392
<b>F8-6472</b>	<b>F8-6475</b>	<b>F8-6511</b>	<b>F8-6555</b>	<b>F8-6638</b>	<b>F8-6732</b>	<b>F8-6754</b>
Ref.Nr.: 1 133 019	Ref.Nr.: 98AB6038CH	Ref.Nr.: 1061721	Ref.Nr.: 1073155	Ref.Nr.: C2Y6-28-460	Ref.Nr.: YS4Z-5493-BA	Ref.Nr.: 98AB-6P082-MB

**Article Description****Article Nr.****Fitting Position**

<b>FOCUS Estate (DNW)</b>		<b>02/1999 → 01/2005</b>	
Alternator Freewheel Clutch	1.8 TDCi		<b>F5-1057</b>
Alternator Freewheel Clutch	ST170		<b>F5-1094</b>
Stabiliser Mounting	1.4 16V, 1.6 16V, 1.8 16V, 1.8 DI / TDDi, 1.8 TDCi, 1.8 Turbo DI / TDDi, 2.0 16V, ST170		<b>F8-5330</b>
Control Arm-/Trailing Arm Bush	1.4 16V, 1.6 16V, 1.8 16V, 1.8 DI / TDDi, 1.8 TDCi, 1.8 Turbo DI / TDDi, 2.0 16V, ST170		<b>F8-6015</b>
Control Arm-/Trailing Arm Bush	1.4 16V, 1.6 16V, 1.8 16V, 1.8 DI / TDDi, 1.8 Turbo DI / TDDi, 2.0 16V		<b>F8-6016</b>
Rubber Buffer, suspension	1.4 16V, 1.6 16V, 1.6 16V Flexifuel, 1.8 16V, 1.8 DI / TDDi, 1.8 TDCi, 1.8 Turbo DI / TDDi, 2.0 16V		<b>F8-6060</b>
Top Strut Mounting	All Models		<b>F8-6066</b>
Mounting, manual transmission	1.4 16V, 1.6 16V, 1.6 16V Flexifuel, 1.8 16V, 2.0 16V		<b>F8-6208</b>
Engine Mounting	All Models		<b>F8-6209</b>
Top Strut Mounting	1.4 16V, 1.6 16V, 1.6 16V Flexifuel, 1.8 16V, 1.8 DI / TDDi, 1.8 TDCi, 1.8 Turbo DI / TDDi, 2.0 16V		<b>F8-6318</b>
Belt Pulley, crankshaft	1.8 DI / TDDi, 1.8 Turbo DI / TDDi	Number of Ribs: 6	<b>F8-6387</b>
Belt Pulley, crankshaft	1.8 TDCi	Number of Ribs: 6	<b>F8-6399</b>
Engine Mounting	1.4 16V, 1.6 16V, 1.8 16V, 1.8 DI / TDDi, 1.8 TDCi, 1.8 Turbo DI / TDDi, 2.0 16V, ST170		<b>F8-6472</b>
Engine Mounting	1.4 16V, 1.6 16V		<b>F8-6475</b>
Anti-Friction Bearing	1.4 16V, 1.6 16V, 1.6 16V Flexifuel, 1.8 16V, 1.8 DI / TDDi, 1.8 TDCi, 1.8 Turbo DI / TDDi, 2.0 16V, ST170		<b>F8-6511</b>
Spring Cap	1.4 16V, 1.6 16V, 1.8 16V, 1.8 DI / TDDi, 1.8 TDCi, 1.8 Turbo DI / TDDi, 2.0 16V, ST170		<b>F8-6555</b>
Mounting, axle beam	All Models		<b>F8-6638</b>
Stabiliser Mounting	1.4 16V, 1.6 16V, 1.8 16V, 1.8 DI / TDDi, 1.8 TDCi, 1.8 Turbo DI / TDDi, 2.0 16V, ST170		<b>F8-6732</b>
Engine Mounting	2.0 16V		<b>F8-6754</b>
Engine Mounting	ST170		<b>F8-6754</b>
Engine Mounting	1.4 16V, 1.6 16V, 1.8 16V, 1.8 TDCi		<b>F8-7030</b>
Protective Cap/Bellow, shock absorber	1.4 16V, 1.6 16V, 1.8 16V, 1.8 DI / TDDi, 1.8 TDCi, 1.8 Turbo DI / TDDi, 2.0 16V		<b>F8-7686</b>
Engine Mounting	1.6 16V, 1.8 16V, 2.0 16V		<b>F8-8165</b>
<b>FOCUS II (DA_)</b>		<b>07/2004 → 09/2012</b>	
Dust Cover Kit, shock absorber	2.5 ST		<b>AK-735194</b>
Dust Cover Kit, shock absorber	2.5 ST		<b>AK-735195</b>
Dust Cover Kit, shock absorber	1.4, 1.6, 1.6 LPG, 1.6 TDCi, 1.6 Ti, 1.8, 1.8 Flexifuel, 1.8 TDCi, 2.0, 2.0 CNG, 2.0 Flex, 2.0 LPG, 2.0 TDCi		<b>AK-735196</b>
Dust Cover Kit, shock absorber	1.4, 1.6, 1.6 TDCi, 1.6 Ti, 1.8 Flexifuel, 1.8 TDCi, 2.0, 2.0 TDCi		<b>AK-735197</b>

<b>AK-735194</b>	<b>AK-735195</b>	<b>AK-735196</b>	<b>AK-735197</b>	<b>F5-1057</b>	<b>F5-1094</b>	<b>F8-5330</b>
Ref.Nr.: 1468902	Ref.Nr.: 1321003	Ref.Nr.: 1305329	Ref.Nr.: 1309147	Ref.Nr.: 5M5Q-10344-AA	Ref.Nr.: VP6S4U10A352	Ref.Nr.: 1073217
<b>F8-6015</b>	<b>F8-6016</b>	<b>F8-6060</b>	<b>F8-6066</b>	<b>F8-6208</b>	<b>F8-6209</b>	<b>F8-6318</b>
Ref.Nr.: 98AG3063AE	Ref.Nr.: 1067918	Ref.Nr.: 1064069	Ref.Nr.: 1061722	Ref.Nr.: 1323096	Ref.Nr.: 3M51GP093	Ref.Nr.: 1115132
<b>F8-6387</b>	<b>F8-6399</b>	<b>F8-6472</b>	<b>F8-6475</b>	<b>F8-6511</b>	<b>F8-6555</b>	<b>F8-6638</b>
Ref.Nr.: 1 079 188	Ref.Nr.: 1151 392	Ref.Nr.: 1 133 019	Ref.Nr.: 98AB6038CH	Ref.Nr.: 1061721	Ref.Nr.: 1073155	Ref.Nr.: C2Y6-28-460

Article Description



Article Nr.

Fitting Position



FOCUS II (DA_)			07/2004 → 09/2012		
Alternator Freewheel Clutch	1.8 TDCi		F5-1057		
Alternator Freewheel Clutch	1.8 Flexifuel	Alternator Charge Current [A]: 120; for OE: 3M5T-10300-VC; Manufacturer Restriction: Denso	F5-1059		
Alternator Freewheel Clutch	2.0 Flex	Alternator Charge Current [A]: 120, 150; for OE: 3M5T-10300-VD; Manufacturer Restriction: Denso	F5-1059		
Alternator Freewheel Clutch	2.0, 2.0 CNG, 2.0 LPG	Alternator Charge Current [A]: 120, 150; for OE: 3M5T-10300-VC, 3M5T-10300-VD; Manufacturer Restriction: Denso;	F5-1059		
Alternator Freewheel Clutch	2.5 RS, 2.5 RS 500	Alternator Charge Current [A]: 120; Manufacturer Restriction: Denso	F5-1059		
Alternator Freewheel Clutch	2.5 ST	Alternator Nr: 104210-3550, 104210-3560, 104210-4640; Manufacturer Restriction: Denso	F5-1151		
Mounting, manual transmission	1.8, 1.8 Flexifuel, 2.0		F8-6207		
Top Strut Mounting	1.4, 1.6, 1.6 LPG, 1.6 TDCi, 1.6 Ti, 1.8, 1.8 Flexifuel, 1.8 TDCi, 2.0, 2.0 CNG, 2.0 LPG, 2.0 TDCi, 2.5 ST		F8-6210		
Anti-Friction Bearing	1.4, 1.6, 1.6 LPG, 1.6 TDCi, 1.6 Ti, 1.8, 1.8 Flexifuel, 1.8 TDCi, 2.0, 2.0 CNG, 2.0 LPG, 2.0 TDCi, 2.5 RS, 2.5 RS 500, 2.5 ST		F8-6268		
Top Strut Mounting	1.4, 1.6, 1.6 LPG, 1.6 TDCi, 1.6 Ti, 1.8, 1.8 Flexifuel, 1.8 TDCi, 2.0, 2.0 CNG, 2.0 LPG, 2.0 TDCi, 2.5 RS, 2.5 RS 500, 2.5 ST		F8-6357		
Mounting, axle beam	1.4, 1.6, 1.6 LPG, 1.6 TDCi, 1.6 Ti, 1.8, 1.8 Flexifuel, 1.8 TDCi, 2.0, 2.0 CNG, 2.0 LPG, 2.0 TDCi, 2.5 RS, 2.5 RS 500, 2.5 ST		F8-6638		D=60
Belt Pulley, crankshaft	1.6 TDCi, 1.6 Ti	Number of Ribs: 6	F8-7082		Belt Pulley Ø [mm]=152; Mounting points diam.[mm]=30; W=34
Top Strut Mounting	1.4, 1.6, 1.6 TDCi, 1.6 Ti, 1.8 Flexifuel, 1.8 TDCi, 2.0, 2.0 TDCi		F8-7156		
Belt Pulley, crankshaft	1.8 TDCi		F8-7649		
Protective Cap/Bellow, shock absorber	1.4, 1.6, 1.6 LPG, 1.6 TDCi, 1.6 Ti, 1.8, 1.8 Flexifuel, 1.8 TDCi, 2.0, 2.0 CNG, 2.0 Flex, 2.0 LPG, 2.0 TDCi, 2.5 RS, 2.5 RS 500, 2.5 ST		F8-7838		H=250
Belt Pulley, crankshaft	2.0 TDCi		F8-7861		
Control Arm-/Trailing Arm Bush	1.4, 1.6, 1.6 LPG, 1.6 TDCi, 1.8, 1.8 Flexifuel, 1.8 TDCi, 2.0, 2.0 CNG, 2.0 LPG, 2.0 TDCi, 2.5 ST		F8-8078		
Control Arm-/Trailing Arm Bush	1.6	PFI	F8-8078		
Control Arm-/Trailing Arm Bush	1.6 Ti	Ti-VCT	F8-8078		
Control Arm-/Trailing Arm Bush	2.0 Flex	2,0 PFI	F8-8078		

<b>F5-1057</b>	<b>F5-1059</b>	<b>F5-1151</b>	<b>F8-6207</b>	<b>F8-6210</b>	<b>F8-6268</b>	<b>F8-6357</b>
Ref.Nr.: 5M5Q-10344-AA	Ref.Nr.: 3M5T-10300-VC	Ref.Nr.:	Ref.Nr.: 1322569	Ref.Nr.: 3M513K155DC	Ref.Nr.: 30639948	Ref.Nr.: 30714395
<b>F8-6638</b>	<b>F8-7082</b>	<b>F8-7156</b>	<b>F8-7649</b>	<b>F8-7838</b>	<b>F8-7861</b>	<b>F8-8078</b>
Ref.Nr.: C2Y6-28-460	Ref.Nr.: 0515.R0	Ref.Nr.: BP4L-34-380C	Ref.Nr.: 1131911	Ref.Nr.: 1305329	Ref.Nr.: 0515 Q8	Ref.Nr.: 3M5J-3A262-BP
<b>F8-8140</b>						
Ref.Nr.: 30778647						



**Article Description****Article Nr.****Fitting Position****FOCUS II (DA\_) 07/2004 → 09/2012**

Engine Mounting	1.4, 1.6, 1.6 TDCi, 1.6 Ti, 1.8, 1.8 Flexifuel, 1.8 TDCi, 2.0, 2.0 TDCi		<b>F8-8140</b>		
Engine Mounting	1.6 TDCi		<b>F8-8197</b>	⊕	

**FOCUS II Convertible 10/2006 → 07/2011**

Dust Cover Kit, shock absorber	All Models		<b>AK-735199</b>		⊕ ⊕ ⊕
Dust Cover Kit, shock absorber	All Models		<b>AK-735200</b>		⊕ ⊕ ⊕
Alternator Freewheel Clutch	2.0	Alternator Charge Current [A]: 120, 150; for OE: 3M5T-10300-VC, 3M5T-10300-VD; Manufacturer Restriction: Denso;	<b>F5-1059</b>		
Anti-Friction Bearing	All Models		<b>F8-6268</b>		
Top Strut Mounting	All Models		<b>F8-6357</b>		
Mounting, axle beam	All Models		<b>F8-6638</b>		⊕ ⊕ ⊕ D=60
Control Arm-/Trailing Arm Bush	1.6	PFI	<b>F8-8078</b>		⊕ ⊕ ⊕
Control Arm-/Trailing Arm Bush	2.0, 2.0 TDCi		<b>F8-8078</b>		⊕ ⊕ ⊕
Engine Mounting	All Models		<b>F8-8140</b>		

**FOCUS II Saloon (DA\_) 04/2005 → 09/2012**

Dust Cover Kit, shock absorber	1.4, 1.6, 1.6 TDCi, 1.6 Ti, 1.8, 1.8 Flexifuel, 1.8 TDCi, 2.0, 2.0 TDCi		<b>AK-735196</b>		⊕ ⊕ ⊕
Dust Cover Kit, shock absorber	1.4, 1.6, 1.6 TDCi, 1.6 Ti, 1.8 Flexifuel, 1.8 TDCi, 2.0, 2.0 TDCi		<b>AK-735197</b>		⊕ ⊕ ⊕
Alternator Freewheel Clutch	1.8 TDCi		<b>F5-1057</b>		
Alternator Freewheel Clutch	1.8 Flexifuel	Alternator Charge Current [A]: 120; for OE: 3M5T-10300-VC; Manufacturer Restriction: Denso	<b>F5-1059</b>		
Alternator Freewheel Clutch	2.0	Alternator Charge Current [A]: 120, 150; for OE: 3M5T-10300-VC, 3M5T-10300-VD; Manufacturer Restriction: Denso;	<b>F5-1059</b>		
Alternator Freewheel Clutch	2.0	Alternator Charge Current [A]: 120, 150; for OE: 3M5T-10300-VD; Manufacturer Restriction: Denso	<b>F5-1059</b>		
Top Strut Mounting	1.4, 1.6, 1.6 TDCi, 1.6 Ti, 1.8, 1.8 Flexifuel, 1.8 TDCi, 2.0, 2.0 TDCi		<b>F8-6210</b>		⊕ ⊕ ⊕
Anti-Friction Bearing	1.4, 1.6, 1.6 TDCi, 1.6 Ti, 1.8, 1.8 Flexifuel, 1.8 TDCi, 2.0, 2.0 TDCi		<b>F8-6268</b>		
Top Strut Mounting	1.4, 1.6, 1.6 TDCi, 1.6 Ti, 1.8, 1.8 Flexifuel, 1.8 TDCi, 2.0, 2.0 TDCi		<b>F8-6357</b>		
Mounting, axle beam	1.4, 1.6, 1.6 TDCi, 1.6 Ti, 1.8, 1.8 Flexifuel, 1.8 TDCi, 2.0, 2.0 TDCi		<b>F8-6638</b>		⊕ ⊕ ⊕ D=60
Belt Pulley, crankshaft	1.6 TDCi	Number of Ribs: 6	<b>F8-7082</b>		Belt Pulley Ø [mm]=152; Mounting points diam.[mm]=30; W=34

<b>AK-735196</b>	<b>AK-735197</b>	<b>AK-735199</b>	<b>AK-735200</b>	<b>F5-1057</b>	<b>F5-1059</b>	<b>F8-6210</b>
Ref.Nr.: 1305329	Ref.Nr.: 1309147	Ref.Nr.: 1305329	Ref.Nr.: 1458447	Ref.Nr.: 5M5Q-10344-AA	Ref.Nr.: 3M5T-10300-VC	Ref.Nr.: 3M513K155DC
<b>F8-6268</b>	<b>F8-6357</b>	<b>F8-6638</b>	<b>F8-7082</b>	<b>F8-7156</b>	<b>F8-8078</b>	<b>F8-8140</b>
Ref.Nr.: 30639948	Ref.Nr.: 30714395	Ref.Nr.: C2Y6-28-460	Ref.Nr.: 0515.R0	Ref.Nr.: BP4L-34-380C	Ref.Nr.: 3M5J-3A262-BP	Ref.Nr.: 30778647
<b>F8-8197</b>						
Ref.Nr.: 1345657						

Article Description



Article Nr.

Fitting Position



**FOCUS II Saloon (DA\_)** 04/2005 → 09/2012

Top Strut Mounting	1.4, 1.6, 1.6 TDCi, 1.6 Ti, 1.8 Flexifuel, 1.8 TDCi, 2.0, 2.0 TDCi		F8-7156		
Belt Pulley, crankshaft	1.8 TDCi		F8-7649		
Protective Cap/Bellow, shock absorber	All Models		F8-7838		H=250
Belt Pulley, crankshaft	2.0 TDCi		F8-7861		
Control Arm-/Trailing Arm Bush	1.4, 1.6, 1.6 TDCi, 1.6 Ti, 1.8, 1.8 Flexifuel, 1.8 TDCi, 2.0, 2.0 TDCi		F8-8078		
Control Arm-/Trailing Arm Bush	1.6 Ti	Ti-VCT	F8-8078		
Control Arm-/Trailing Arm Bush	1.8 Flexifuel	PFI	F8-8078		
Engine Mounting	1.4, 1.6, 1.6 TDCi, 1.6 Ti, 1.8, 1.8 Flexifuel, 1.8 TDCi, 2.0, 2.0 TDCi		F8-8140		
Engine Mounting	2.0 TDCi	Transmission Type: MMT6	F8-8196		
Engine Mounting	1.6 TDCi		F8-8197		

**FOCUS II Station Wagon (DA\_)** 07/2004 → 09/2012

Dust Cover Kit, shock absorber	All Models		AK-735196		
Alternator Freewheel Clutch	1.8 TDCi		F5-1057		
Alternator Freewheel Clutch	1.8 Flexifuel	Alternator Charge Current [A]: 120; for OE: 3M5T-10300-VC; Manufacturer Restriction: Denso	F5-1059		
Alternator Freewheel Clutch	2.0	Alternator Charge Current [A]: 120;  AODA; for OE: 3M5T-10300-VC; Manufacturer Restriction: Denso	F5-1059		
Alternator Freewheel Clutch	2.0 LPG	Alternator Charge Current [A]: 120, 150; for OE: 3M5T-10300-VD; Manufacturer Restriction: Denso	F5-1059		
Mounting, manual transmission	1.8, 1.8 Flexifuel, 2.0		F8-6207		
Top Strut Mounting	1.4, 1.6, 1.6 LPG, 1.6 TDCi, 1.6 Ti, 1.8, 1.8 Flexifuel, 1.8 TDCi, 2.0, 2.0 LPG, 2.0 TDCi		F8-6210		
Anti-Friction Bearing	1.4, 1.6, 1.6 LPG, 1.6 TDCi, 1.6 Ti, 1.8, 1.8 Flexifuel, 1.8 TDCi, 2.0, 2.0 LPG, 2.0 TDCi		F8-6268		
Top Strut Mounting	1.8, 2.0 TDCi		F8-6357		
Mounting, axle beam	1.4, 1.6, 1.6 LPG, 1.6 TDCi, 1.6 Ti, 1.8, 1.8 Flexifuel, 1.8 TDCi, 2.0, 2.0 LPG, 2.0 TDCi		F8-6638		D=60
Belt Pulley, crankshaft	1.6 TDCi	Number of Ribs: 6	F8-7082		Belt Pulley Ø [mm]=152; Mounting points diam.[mm]=30; W=34
Top Strut Mounting	1.4, 1.6, 1.6 TDCi, 1.6 Ti, 1.8 Flexifuel, 1.8 TDCi, 2.0, 2.0 TDCi		F8-7156		
Belt Pulley, crankshaft	1.8 TDCi		F8-7649		

<b>AK-735196</b>	<b>F5-1057</b>	<b>F5-1059</b>	<b>F8-6207</b>	<b>F8-6210</b>	<b>F8-6268</b>	<b>F8-6357</b>
Ref.Nr.: 1305329	Ref.Nr.: 5M5Q-10344-AA	Ref.Nr.: 3M5T-10300-VC	Ref.Nr.: 1322569	Ref.Nr.: 3M513K155DC	Ref.Nr.: 30639948	Ref.Nr.: 30714395
<b>F8-6638</b>	<b>F8-7082</b>	<b>F8-7156</b>	<b>F8-7649</b>	<b>F8-7838</b>	<b>F8-7861</b>	<b>F8-8078</b>
Ref.Nr.: C2Y6-28-460	Ref.Nr.: 0515.R0	Ref.Nr.: BP4L-34-380C	Ref.Nr.: 1131911	Ref.Nr.: 1305329	Ref.Nr.: 0515 Q8	Ref.Nr.: 3M5J-3A262-BP
<b>F8-8140</b>	<b>F8-8196</b>	<b>F8-8197</b>				
Ref.Nr.: 30778647	Ref.Nr.: 1543750	Ref.Nr.: 1345657				



Article Description



Article Nr.

Fitting Position



### FOCUS II Station Wagon (DA\_) 07/2004 → 09/2012

Protective Cap/Bellow, shock absorber	All Models		<b>F8-7838</b>	⊕ ⊕	H=250
Belt Pulley, crankshaft	2.0 TDCi		<b>F8-7861</b>		
Control Arm-/Trailing Arm Bush	1.4, 1.6, 1.6 LPG, 1.6 TDCi, 1.6 Ti, 1.8 Flexifuel, 1.8 TDCi, 2.0, 2.0 LPG, 2.0 TDCi		<b>F8-8078</b>	⊕ ⊕ ⊕	
Control Arm-/Trailing Arm Bush	1.6, 1.8, 1.8 Flexifuel	PFI	<b>F8-8078</b>	⊕ ⊕ ⊕	
Engine Mounting	1.4, 1.6, 1.6 TDCi, 1.6 Ti, 1.8, 1.8 Flexifuel, 1.8 TDCi, 2.0, 2.0 TDCi		<b>F8-8140</b>		
Engine Mounting	1.6 TDCi		<b>F8-8197</b>	⊕	

### FOCUS III 07/2010 →

Dust Cover Kit, shock absorber	1.0 EcoBoost, 1.6 EcoBoost, 1.6 Flexifuel, 1.6 LPG, 1.6 TDCi, 1.6 TDCi ECONetic, 1.6 Ti, 2.0 GDi, 2.0 TDCi		<b>AK-735451</b>	⊕ ⊕ ⊕	
Anti-Friction Bearing	1.0 EcoBoost, 1.6 EcoBoost, 1.6 Flexifuel, 1.6 LPG, 1.6 TDCi, 1.6 TDCi ECONetic, 1.6 Ti, 2.0 GDi, 2.0 ST, 2.0 TDCi		<b>F8-6268</b>		
Top Strut Mounting	1.0 EcoBoost, 1.6 EcoBoost, 1.6 Flexifuel, 1.6 LPG, 1.6 TDCi, 1.6 TDCi ECONetic, 1.6 Ti, 2.0 GDi, 2.0 ST, 2.0 TDCi		<b>F8-6357</b>		
Rubber Buffer, suspension	1.0 EcoBoost, 1.6 EcoBoost, 1.6 Flexifuel, 1.6 LPG, 1.6 TDCi, 1.6 TDCi ECONetic, 1.6 Ti, 2.0 GDi, 2.0 TDCi		<b>F8-7479</b>	⊕ ⊕ ⊕	
Protective Cap/Bellow, shock absorber	1.0 EcoBoost, 1.6 EcoBoost, 1.6 Flexifuel, 1.6 LPG, 1.6 TDCi, 1.6 TDCi ECONetic, 1.6 Ti, 2.0 GDi, 2.0 TDCi		<b>F8-7480</b>	⊕ ⊕ ⊕	
Rubber Buffer, suspension	1.0 EcoBoost, 1.6 EcoBoost, 1.6 Flexifuel, 1.6 LPG, 1.6 TDCi, 1.6 TDCi ECONetic, 1.6 Ti, 2.0 GDi, 2.0 ST, 2.0 TDCi		<b>F8-7483</b>	⊕ ⊕ ⊕	
Protective Cap/Bellow, shock absorber	1.0 EcoBoost, 1.6 EcoBoost, 1.6 Flexifuel, 1.6 LPG, 1.6 TDCi, 1.6 TDCi ECONetic, 1.6 Ti, 2.0 GDi, 2.0 ST, 2.0 TDCi		<b>F8-7838</b>	⊕ ⊕ ⊕	H=250
Control Arm-/Trailing Arm Bush	1.6 EcoBoost, 1.6 TDCi, 1.6 Ti, 2.0 TDCi		<b>F8-7853</b>	⊕ ⊕ ⊕	H=64.7; d=14; D1=54; D2=44.7
Control Arm-/Trailing Arm Bush	1.6 Ti		<b>F8-7854</b>	⊕	d=18.6; D=74
Control Arm-/Trailing Arm Bush	1.6 Ti		<b>F8-7855</b>	⊕	d=18.6; D=74
Engine Mounting	1.6 Flexifuel, 1.6 LPG, 1.6 Ti, 2.0 ST, 2.0 TDCi		<b>F8-8140</b>		
Engine Mounting	2.0 TDCi	Transmission Type: MMT6	<b>F8-8196</b>	⊕	
Engine Mounting	1.6 TDCi, 1.6 TDCi ECONetic		<b>F8-8197</b>	⊕	

### FOCUS III Saloon 07/2010 →

Dust Cover Kit, shock absorber	1.0 EcoBoost, 1.6 EcoBoost, 1.6 Flexifuel, 1.6 TDCi, 1.6 Ti, 2.0 TDCi		<b>AK-735451</b>	⊕ ⊕ ⊕	
--------------------------------	---	--	------------------	-------	--



Article Description



Article Nr.

Fitting Position



### FOCUS III Saloon

07/2010 →

Anti-Friction Bearing	1.0 EcoBoost, 1.6 EcoBoost, 1.6 Flexifuel, 1.6 TDCi, 1.6 Ti, 2.0 TDCi		F8-6268		
Top Strut Mounting	1.0 EcoBoost, 1.6 EcoBoost, 1.6 Flexifuel, 1.6 TDCi, 1.6 Ti, 2.0 TDCi		F8-6357		
Rubber Buffer, suspension	1.0 EcoBoost, 1.6 EcoBoost, 1.6 Flexifuel, 1.6 TDCi, 1.6 Ti, 2.0 TDCi		F8-7479		
Protective Cap/Bellow, shock absorber	1.0 EcoBoost, 1.6 EcoBoost, 1.6 Flexifuel, 1.6 TDCi, 1.6 Ti, 2.0 TDCi		F8-7480		
Rubber Buffer, suspension	1.0 EcoBoost, 1.6 EcoBoost, 1.6 Flexifuel, 1.6 TDCi, 1.6 Ti, 2.0 TDCi		F8-7483		
Protective Cap/Bellow, shock absorber	1.0 EcoBoost, 1.6 EcoBoost, 1.6 Flexifuel, 1.6 TDCi, 1.6 Ti, 2.0 TDCi		F8-7838		
Control Arm-/Trailing Arm Bush	1.6 EcoBoost, 1.6 TDCi, 1.6 Ti, 2.0 TDCi		F8-7853		
Engine Mounting	1.6 Flexifuel, 1.6 Ti, 2.0 TDCi		F8-8140		
Engine Mounting	2.0 TDCi	Transmission Type: MMT6	F8-8196		
Engine Mounting	1.6 TDCi		F8-8197		

### FOCUS III Turnier

07/2010 →

Anti-Friction Bearing	1.0 EcoBoost, 1.6 EcoBoost, 1.6 Flexifuel, 1.6 LPG, 1.6 TDCi, 1.6 TDCi ECOnetic, 1.6 Ti, 2.0 ST, 2.0 TDCi		F8-6268		
Rubber Buffer, suspension	1.0 EcoBoost, 1.6 EcoBoost, 1.6 Flexifuel, 1.6 LPG, 1.6 TDCi, 1.6 TDCi ECOnetic, 1.6 Ti, 2.0 ST, 2.0 TDCi		F8-7483		
Protective Cap/Bellow, shock absorber	1.0 EcoBoost, 1.6 EcoBoost, 1.6 Flexifuel, 1.6 LPG, 1.6 TDCi, 1.6 TDCi ECOnetic, 1.6 Ti, 2.0 ST, 2.0 TDCi		F8-7838		
Control Arm-/Trailing Arm Bush	1.6 EcoBoost, 1.6 TDCi, 1.6 Ti, 2.0 TDCi		F8-7853		
Engine Mounting	1.6 Flexifuel, 1.6 LPG, 1.6 Ti, 2.0 ST, 2.0 TDCi		F8-8140		
Engine Mounting	1.6 TDCi, 1.6 TDCi ECOnetic		F8-8197		

### FOCUS C-MAX

10/2003 → 03/2007

Dust Cover Kit, shock absorber	All Models		AK-735196		
Dust Cover Kit, shock absorber	1.6, 1.6 TDCi, 1.6 Ti, 1.8, 1.8 Flexifuel, 1.8 TDCi, 2.0, 2.0 TDCi		AK-735198		
Alternator Freewheel Clutch	1.8 TDCi		F5-1057		
Alternator Freewheel Clutch	1.8	Alternator Charge Current [A]: 120;  Q7DA; for OE: 3M5T-10300-VC; Manufacturer Restriction: Denso	F5-1059		
Alternator Freewheel Clutch	1.8 Flexifuel	Alternator Charge Current [A]: 120; for OE: 3M5T-10300-VC; Manufacturer Restriction: Denso	F5-1059		
Alternator Freewheel Clutch	2.0	Alternator Charge Current [A]: 120, 150; for OE: 3M5T-10300-VC, 3M5T-10300-VD; Manufacturer Restriction: Denso;	F5-1059		

<b>AK-735196</b>	<b>AK-735198</b>	<b>F5-1057</b>	<b>F5-1059</b>	<b>F8-6207</b>	<b>F8-6268</b>	<b>F8-6357</b>
Ref.Nr.: 1305329	Ref.Nr.: 1309151	Ref.Nr.: 5M5Q-10344-AA	Ref.Nr.: 3M5T-10300-VC	Ref.Nr.: 1322569	Ref.Nr.: 30639948	Ref.Nr.: 30714395
<b>F8-7479</b>	<b>F8-7480</b>	<b>F8-7483</b>	<b>F8-7838</b>	<b>F8-7853</b>	<b>F8-8140</b>	<b>F8-8196</b>
Ref.Nr.: 1713375	Ref.Nr.: 8V61-18159-AB	Ref.Nr.: BV61-3K100-AA	Ref.Nr.: 1305329	Ref.Nr.: 1749991	Ref.Nr.: 30778647	Ref.Nr.: 1543750
<b>F8-8197</b>						
Ref.Nr.: 1345657						

**Article Description****Article Nr.****Fitting Position**

<b>FOCUS C-MAX</b>				<b>10/2003 → 03/2007</b>	
Mounting, manual transmission	1.8, 2.0		<b>F8-6207</b>		
Top Strut Mounting	1.6, 1.6 TDCi, 1.6 Ti, 1.8, 1.8 Flexifuel, 1.8 TDCi, 2.0, 2.0 TDCi		<b>F8-6210</b>		
Anti-Friction Bearing	1.6, 1.6 TDCi, 1.6 Ti, 1.8, 1.8 Flexifuel, 1.8 TDCi, 2.0, 2.0 TDCi		<b>F8-6268</b>		
Top Strut Mounting	1.6, 1.6 TDCi, 1.6 Ti, 1.8, 1.8 Flexifuel, 1.8 TDCi, 2.0, 2.0 TDCi		<b>F8-6357</b>		
Stabiliser Mounting	1.6, 1.6 TDCi, 1.6 Ti, 1.8, 1.8 Flexifuel, 1.8 TDCi, 2.0, 2.0 TDCi		<b>F8-6637</b>		
Mounting, axle beam	1.6, 1.6 TDCi, 1.6 Ti, 1.8, 1.8 Flexifuel, 1.8 TDCi, 2.0, 2.0 TDCi		<b>F8-6638</b>		D=60
Belt Pulley, crankshaft	1.6 TDCi	Number of Ribs: 6	<b>F8-7082</b>		Belt Pulley Ø [mm]=152; Mounting points diam.[mm]=30; W=34
Top Strut Mounting	1.6, 1.6 TDCi, 1.6 Ti, 1.8, 1.8 Flexifuel, 1.8 TDCi, 2.0, 2.0 TDCi		<b>F8-7156</b>		
Rubber Buffer, suspension	1.6, 1.6 TDCi, 1.6 Ti, 1.8, 1.8 Flexifuel, 1.8 TDCi, 2.0, 2.0 TDCi	<b>ST</b>	<b>F8-7583</b>		H=122.5
Belt Pulley, crankshaft	1.8 TDCi		<b>F8-7649</b>		
Control Arm-/Trailing Arm Bush	All Models		<b>F8-8078</b>		
Engine Mounting	1.6, 1.6 TDCi, 1.6 Ti, 1.8, 1.8 TDCi, 2.0, 2.0 TDCi		<b>F8-8140</b>		
Engine Mounting	1.6 TDCi		<b>F8-8197</b>		
<b>FUSION (JU_)</b>				<b>08/2002 → 12/2012</b>	
Dust Cover Kit, shock absorber	1.25, 1.4, 1.4 TDCi, 1.6, 1.6 TDCi	<b>ST</b>	<b>AK-735095</b>		
Dust Cover Kit, shock absorber	1.25, 1.4, 1.4 TDCi, 1.6, 1.6 TDCi		<b>AK-735201</b>		
Alternator Freewheel Clutch	1.4 TDCi		<b>F5-1052</b>		
Control Arm-/Trailing Arm Bush	1.25, 1.4, 1.4 TDCi, 1.6, 1.6 TDCi		<b>F8-6159</b>		
Control Arm-/Trailing Arm Bush	1.25, 1.4, 1.4 TDCi, 1.6, 1.6 TDCi		<b>F8-6160</b>		
Anti-Friction Bearing	1.25, 1.4, 1.4 TDCi, 1.6, 1.6 TDCi		<b>F8-6317</b>		
Top Strut Mounting	All Models		<b>F8-6358</b>		
Belt Pulley, crankshaft	1.6 TDCi	Number of Ribs: 6	<b>F8-7082</b>		Belt Pulley Ø [mm]=152; Mounting points diam.[mm]=30; W=34
Top Strut Mounting	1.25, 1.4, 1.4 TDCi, 1.6, 1.6 TDCi		<b>F8-7431</b>		
Protective Cap/Bellow, shock absorber	1.25, 1.4, 1.4 TDCi, 1.6, 1.6 TDCi		<b>F8-7683</b>		
Stabiliser Mounting	All Models		<b>F8-7934</b>		d=17
Control Arm-/Trailing Arm Bush	All Models		<b>F8-8001</b>		

<b>AK-735095</b>	<b>AK-735201</b>	<b>F5-1052</b>	<b>F8-6159</b>	<b>F8-6160</b>	<b>F8-6207</b>	<b>F8-6210</b>
Ref.Nr.: 1J0512131B	Ref.Nr.: 1254213	Ref.Nr.:	Ref.Nr.: 1212807-PART	Ref.Nr.: 1212807-PART	Ref.Nr.: 1322569	Ref.Nr.: 3M513K155DC
<b>F8-6268</b>	<b>F8-6317</b>	<b>F8-6357</b>	<b>F8-6358</b>	<b>F8-6637</b>	<b>F8-6638</b>	<b>F8-7082</b>
Ref.Nr.: 30639948	Ref.Nr.: 1146152	Ref.Nr.: 30714395	Ref.Nr.: 1330706	Ref.Nr.: 1305960	Ref.Nr.: C2Y6-28-460	Ref.Nr.: 0515.R0
<b>F8-7156</b>	<b>F8-7431</b>	<b>F8-7583</b>	<b>F8-7649</b>	<b>F8-7683</b>	<b>F8-7934</b>	<b>F8-8001</b>
Ref.Nr.: BP4L-34-380C	Ref.Nr.: 1469224	Ref.Nr.: 1370318	Ref.Nr.: 1131911	Ref.Nr.: 1254213	Ref.Nr.: 1152852	Ref.Nr.: 1426699

Article Description



Article Nr.

Fitting Position



<b>FUSION (JU_)</b>		08/2002 → 12/2012		
Engine Mounting	All Models	F8-8139	↓	
Repair Kit, suspension strut	All Models	F8-8213	↖ ↗ ↘	
<b>GALAXY (WGR)</b>		03/1995 → 05/2006		
Dust Cover Kit, shock absorber	1.9 TDI, 2.0 i, 2.3 16V, 2.8 i V6, 2.8 i V6 4x4, 2.8 V6	AK-735034	↖ ↗ ↘	
Alternator Freewheel Clutch	1.9 TDI, 2.8 i V6, 2.8 i V6 4x4, 2.8 V6	F5-1004		
Alternator Freewheel Clutch	1.9 TDI	F5-1007		
Top Strut Mounting	1.9 TDI, 2.0 i, 2.3 16V, 2.8 i V6, 2.8 i V6 4x4, 2.8 V6	F8-1034	↖ ↗ ↘ H=50; d=27; D=98	
Top Strut Mounting	1.9 TDI, 2.0 i, 2.3 16V, 2.8 i V6, 2.8 i V6 4x4, 2.8 V6	F8-1034S	↖ ↗ ↘ H=51; d=14; D=96	
Anti-Friction Bearing	All Models	F8-3039	↖ ↗ ↘ H=14; d1=14; D=45	
Bellow, steering	1.9 TDI, 2.0 i, 2.3 16V, 2.8 i V6, 2.8 i V6 4x4, 2.8 V6	F8-5051	↖ ↗ ↘ H=180; d1=10; d2=49	
Stabiliser Mounting	1.9 TDI, 2.0 i, 2.3 16V, 2.8 i V6, 2.8 i V6 4x4, 2.8 V6	F8-5407	↖ ↗ ↘ d=17	
Mounting, axle beam	1.9 TDI, 2.0 i, 2.3 16V, 2.8 i V6, 2.8 i V6 4x4, 2.8 V6	F8-5530	↖ ↗ ↘	
Belt Pulley, crankshaft	1.9 TDI	Number of Ribs: 5; Parameter: 6PK	F8-5649	H=31.5; d=30.02; Mounting points diam.[mm]=8.5; D1=161.5; D2=160.5
Rubber Buffer, suspension	1.9 TDI, 2.0 i, 2.3 16V, 2.8 i V6, 2.8 i V6 4x4, 2.8 V6		F8-5995	↖ ↗ ↘ H=83
Belt Pulley, crankshaft	1.9 TDI	08/2003 →; Number of Ribs: 5; Parameter: 6PK	F8-6396	H=41.6; d=30; Mounting points diam.[mm]=7, 8.6; D=139.7
Belt Pulley, crankshaft	1.9 TDI	Number of Ribs: 5; Parameter: 6PK	F8-6396	H=41.6; d=30; Mounting points diam.[mm]=7, 8.6; D=139.7
Stabiliser Mounting	1.9 TDI, 2.0 i, 2.3 16V, 2.8 i V6, 2.8 i V6 4x4, 2.8 V6		F8-6702	↖ ↗ ↘ d=20.6
Stabiliser Mounting	1.9 TDI, 2.0 i, 2.3 16V, 2.8 i V6, 2.8 i V6 4x4		F8-6703	↖ ↗ ↘ H=29; d=21
Engine Mounting	2.8 V6		F8-7032	
Protective Cap/Bellow, shock absorber	1.9 TDI, 2.0 i, 2.3 16V, 2.8 i V6, 2.8 i V6 4x4, 2.8 V6		F8-7688	H=220
Engine Mounting	1.9 TDI		F8-8150	
Control Arm-/Trailing Arm Bush	1.9 TDI, 2.0 i, 2.3 16V, 2.8 i V6, 2.8 i V6 4x4, 2.8 V6		G9-664	↖ ↗ ↘ H=50; d=18; D=60
Control Arm-/Trailing Arm Bush	1.9 TDI, 2.0 i, 2.3 16V, 2.8 i V6, 2.8 i V6 4x4, 2.8 V6		G9-665	↖ ↗ ↘ ↙ H=60; d=14; D1=35; D2=38
Bellow, steering	1.9 TDI, 2.0 i, 2.3 16V, 2.3 4x4, 2.8 i V6, 2.8 i V6 4x4	with clamps; ⚙	LM-10023S	↖ ↗ ↘ d1=10; d2=49; L [mm]=180
Bellow Set, drive shaft	1.9 TDI	with clamps	MK-810160	↖ ↗ ↘ L=116
<b>GALAXY (WA6)</b>		05/2006 → 06/2015		
Alternator Freewheel Clutch	2.0 TDCi, 2.2 TDCi		F5-1046	
Alternator Freewheel Clutch	1.8 TDCi		F5-1057	
Alternator Freewheel Clutch	2.0	Manufacturer Restriction: Denso	F5-1059	
Alternator Freewheel Clutch	2.0, 2.0 Flexifuel		F5-1075	
Alternator Freewheel Clutch	2.0 EcoBoost		F5-1134	

<b>AK-735034</b>	<b>F5-1004</b>	<b>F5-1007</b>	<b>F5-1046</b>	<b>F5-1057</b>	<b>F5-1059</b>	<b>F5-1075</b>
Ref.Nr.:	Ref.Nr.: 038903119T	Ref.Nr.: 028903119AQ	Ref.Nr.: 30667687	Ref.Nr.: 5M5Q-10344-AA	Ref.Nr.: 3M5T-10300-VC	Ref.Nr.: 30667610
<b>F5-1134</b>	<b>F8-1034</b>	<b>F8-1034S</b>	<b>F8-3039</b>	<b>F8-5051</b>	<b>F8-5407</b>	<b>F8-5530</b>
Ref.Nr.: 31285489	Ref.Nr.: 357412331A	Ref.Nr.: 7201848S1	Ref.Nr.: 357412249A	Ref.Nr.: 7398680	Ref.Nr.: 7200957	Ref.Nr.: 95VW5K818BC
<b>F8-5649</b>	<b>F8-5995</b>	<b>F8-6396</b>	<b>F8-6399</b>	<b>F8-6702</b>	<b>F8-6703</b>	<b>F8-7032</b>
Ref.Nr.: 028105243T	Ref.Nr.: 1011898	Ref.Nr.: 03G105243	Ref.Nr.: 1151 392	Ref.Nr.: 7M0511413A	Ref.Nr.: 7M0511414B	Ref.Nr.: 1118741

**Article Description****Article Nr.****Fitting Position**

<b>GALAXY (WA6)</b>			<b>05/2006 → 06/2015</b>		
Belt Pulley, crankshaft	1.8 TDCi	Number of Ribs: 6	<b>F8-6399</b>		
Top Strut Mounting	1.6 EcoBoost, 1.6 TDCi, 1.8 TDCi, 2.0, 2.0 EcoBoost, 2.0 Flexifuel, 2.0 TDCi, 2.2 TDCi, 2.3		<b>F8-7606</b>		
Anti-Friction Bearing	1.6 EcoBoost, 1.6 TDCi, 1.8 TDCi, 2.0, 2.0 EcoBoost, 2.0 Flexifuel, 2.0 TDCi, 2.2 TDCi, 2.3		<b>F8-7607</b>		
Top Strut Mounting	1.6 EcoBoost, 1.6 TDCi, 1.8 TDCi, 2.0, 2.0 EcoBoost, 2.0 Flexifuel, 2.0 TDCi, 2.2 TDCi, 2.3		<b>F8-7608</b>		
Control Arm-/Trailing Arm Bush	1.6 EcoBoost, 1.6 TDCi, 1.8 TDCi, 2.0, 2.0 EcoBoost, 2.0 Flexifuel, 2.0 TDCi, 2.2 TDCi, 2.3		<b>F8-7877</b>		
Control Arm-/Trailing Arm Bush	1.6 EcoBoost, 1.6 TDCi, 1.8 TDCi, 2.0, 2.0 EcoBoost, 2.0 Flexifuel, 2.0 TDCi, 2.2 TDCi, 2.3		<b>F8-7878</b>		
Control Arm-/Trailing Arm Bush	All Models		<b>F8-8074</b>		
Control Arm-/Trailing Arm Bush	All Models		<b>F8-8075</b>		
<b>KA (RB_)</b>			<b>09/1996 → 11/2008</b>		
Dust Cover Kit, shock absorber	1.0 i, 1.3 i		<b>AK-735404</b>		
Dust Cover Kit, shock absorber	1.6 i		<b>AK-735405</b>		
Stabiliser Mounting	1.0 i, 1.3 i		<b>F8-5328</b>		d=15
Top Strut Mounting	1.6 i		<b>F8-5409</b>		d=22; D1=99; D2=106
Top Strut Mounting	1.0 i, 1.3 i, 1.6 i		<b>F8-5410</b>		
Top Strut Mounting	1.0 i, 1.3 i		<b>F8-5412</b>		
Anti-Friction Bearing	1.3 i		<b>F8-5413</b>		
Mounting, axle beam	1.0 i, 1.3 i, 1.6 i		<b>F8-6074</b>		H1=70; H2=55; D=63.2
Top Strut Mounting	1.0 i, 1.3 i, 1.6 i		<b>F8-6312</b>		
Locking ring	1.3 i, 1.6 i		<b>F8-6556</b>		
Spring Cap	1.0 i, 1.3 i		<b>F8-6557</b>		
Spring Cap	1.3 i, 1.6 i	02/2000 →	<b>F8-6558</b>		
Engine Mounting	1.3 i		<b>F8-6756</b>		
Engine Mounting	1.3 i		<b>F8-6958</b>		
Control Arm-/Trailing Arm Bush	1.0 i, 1.3 i, 1.6 i		<b>G9-585</b>		H1=46; H2=25; d=12; D=46
Control Arm-/Trailing Arm Bush	1.0 i, 1.3 i, 1.6 i		<b>G9-586</b>		H1=27; H2=46; d=12; D1=54; D2=62
Bellow, steering	1.0 i, 1.3 i	with clamps;	<b>LM-10007S</b>		d1=14; d2=56; L [mm]=175
<b>KA Van (RB)</b>			<b>05/2002 → 05/2005</b>		
Top Strut Mounting	All Models		<b>F8-5412</b>		

<b>AK-735404</b>	<b>AK-735405</b>	<b>F8-5328</b>	<b>F8-5409</b>	<b>F8-5410</b>	<b>F8-5412</b>	<b>F8-5413</b>
Ref.Nr.: 6532212	Ref.Nr.: 95AB-3K036-AD	Ref.Nr.: 96FB5484CA	Ref.Nr.: 1039001	Ref.Nr.: 1E0028012A	Ref.Nr.: 1E0034390	Ref.Nr.: 1002513
<b>F8-6074</b>	<b>F8-6312</b>	<b>F8-6399</b>	<b>F8-6556</b>	<b>F8-6557</b>	<b>F8-6558</b>	<b>F8-6756</b>
Ref.Nr.: 1016439	Ref.Nr.: 1E003438X	Ref.Nr.: 1151 392	Ref.Nr.: 1010127	Ref.Nr.: 7350848	Ref.Nr.: 1111753	Ref.Nr.: 97KB-6B032-AG
<b>F8-6958</b>	<b>F8-7435</b>	<b>F8-7606</b>	<b>F8-7607</b>	<b>F8-7608</b>	<b>F8-7877</b>	<b>F8-7878</b>
Ref.Nr.: 1032120	Ref.Nr.: 9S5118198BC	Ref.Nr.: 1734710	Ref.Nr.: 1510474	Ref.Nr.: 6G91-3K099-NB	Ref.Nr.: 1865033	Ref.Nr.: 31 277 755

Article Description



Article Nr.

Fitting Position



Article Description		Article Nr.	Fitting Position	10/2008 →
<b>KA (RU8)</b>				
Top Strut Mounting	All Models	F8-7435		
Rubber Buffer, suspension	All Models	F8-7594		H=228
<b>KUGA I</b>				
03/2008 → 11/2012				
Anti-Friction Bearing	All Models	F8-6268		
Top Strut Mounting	All Models	F8-6357		
Mounting, axle beam	2.0 TDCi, 2.0 TDCi 4x4, 2.5 4x4	F8-6638		D=60
Protective Cap/Bellow, shock absorber	All Models	F8-7838		H=250
Control Arm-/Trailing Arm Bush	All Models	F8-8078		
Engine Mounting	All Models	F8-8140		
Engine Mounting	2.0 TDCi, 2.0 TDCi 4x4	F8-8196		Transmission Type: MMT6
<b>KUGA II (DM2)</b>				
03/2013 →				
Protective Cap/Bellow, shock absorber	1.6 EcoBoost, 1.6 EcoBoost 4x4, 2.0 TDCi, 2.0 TDCi 4x4	F8-7480		
Protective Cap/Bellow, shock absorber	1.6 EcoBoost, 1.6 EcoBoost 4x4, 2.0 TDCi, 2.0 TDCi 4x4	F8-7838		H=250
Engine Mounting	1.6 EcoBoost, 1.6 EcoBoost 4x4, 2.0 TDCi, 2.0 TDCi 4x4	F8-8140		
Engine Mounting	2.0 TDCi, 2.0 TDCi 4x4	F8-8196		Transmission Type: MMT6
<b>METROSTAR</b>				
10/2000 → 02/2007				
Alternator Freewheel Clutch	2.5	F5-1066		
<b>MONDEO (GBP)</b>				
02/1993 → 08/1996				
Dust Cover Kit, shock absorber	1.6 i 16V, 1.8 i 16V, 1.8 i 16V 4x4, 1.8 TD, 2.0 i 16V, 2.0 i 16V 4x4, 2.5 i 24V	AK-735033		
Dust Cover Kit, shock absorber	1.6 i 16V, 1.8 i 16V, 1.8 i 16V 4x4, 1.8 TD, 2.0 i 16V, 2.0 i 16V 4x4, 2.5 i 24V	AK-735035		
Control Arm-/Trailing Arm Bush	1.6 i 16V, 1.8 i 16V, 1.8 TD, 2.0 i 16V, 2.5 i 24V	F8-5136		H=46; d=12; D=60
Top Strut Mounting	1.6 i 16V, 1.8 i 16V, 1.8 i 16V 4x4, 1.8 TD, 2.0 i 16V, 2.0 i 16V 4x4, 2.5 i 24V	F8-5503		
Top Strut Mounting	1.6 i 16V, 1.8 i 16V, 1.8 i 16V 4x4, 1.8 TD, 2.0 i 16V, 2.0 i 16V 4x4, 2.5 i 24V	F8-5504		
Stabiliser Mounting	1.6 i 16V, 1.8 i 16V, 1.8 i 16V 4x4, 1.8 TD, 2.0 i 16V, 2.0 i 16V 4x4, 2.5 i 24V	F8-6137		d=19
Anti-Friction Bearing	1.6 i 16V, 1.8 i 16V, 1.8 i 16V 4x4, 1.8 TD, 2.0 i 16V, 2.0 i 16V 4x4, 2.5 i 24V	F8-6262		
Top Strut Mounting	1.6 i 16V, 1.8 i 16V, 1.8 i 16V 4x4, 1.8 TD, 2.0 i 16V, 2.0 i 16V 4x4, 2.5 i 24V	F8-6308		
Stabiliser Mounting	1.6 i 16V, 1.8 i 16V, 1.8 i 16V 4x4, 1.8 TD, 2.0 i 16V, 2.0 i 16V 4x4, 2.5 i 24V	F8-6639		d=16

<b>AK-735033</b>	<b>AK-735035</b>	<b>F5-1066</b>	<b>F8-5136</b>	<b>F8-5503</b>	<b>F8-5504</b>	<b>F8-6137</b>
Ref.Nr.: 1023326	Ref.Nr.:	Ref.Nr.:	Ref.Nr.: 95BG3A262AA	Ref.Nr.: 6807407	Ref.Nr.: 6799585	Ref.Nr.: 1128725
<b>F8-6262</b>	<b>F8-6268</b>	<b>F8-6308</b>	<b>F8-6357</b>	<b>F8-6638</b>	<b>F8-6639</b>	<b>F8-6722</b>
Ref.Nr.: 97BG-3K099-AA	Ref.Nr.: 30639948	Ref.Nr.: 98BG3K099AA	Ref.Nr.: 30714395	Ref.Nr.: C2Y6-28-460	Ref.Nr.: 93BB4A037EA	Ref.Nr.: 6829045
<b>F8-7435</b>	<b>F8-7480</b>	<b>F8-7594</b>	<b>F8-7838</b>	<b>F8-8078</b>	<b>F8-8140</b>	<b>F8-8196</b>
Ref.Nr.: 9S5118198BC	Ref.Nr.: 8V61-18159-AB	Ref.Nr.: 1 639 562	Ref.Nr.: 1305329	Ref.Nr.: 3M5J-3A262-BP	Ref.Nr.: 30778647	Ref.Nr.: 1543750



**Article Description****Article Nr.****Fitting Position**

<b>MONDEO (GBP)</b>		<b>02/1993 → 08/1996</b>	
Control Arm-/Trailing Arm Bush	1.6 i 16V, 1.8 i 16V, 1.8 i 16V 4x4, 1.8 TD, 2.0 i 16V, 2.0 i 16V 4x4, 2.5 i 24V	<b>F8-6722</b>	H1=28; H2=35; d=12; D=36,5
Engine Mounting	1.6 i 16V, 1.8 i 16V, 2.0 i 16V, 2.5 i 24V	<b>F8-7031</b>	
Stabiliser Mounting	1.6 i 16V, 1.8 i 16V, 1.8 TD, 2.0 i 16V, 2.5 i 24V	<b>F8-7915</b>	
Mounting, axle beam	1.6 i 16V, 1.8 i 16V, 1.8 i 16V 4x4, 1.8 TD, 2.0 i 16V, 2.0 i 16V 4x4, 2.5 i 24V	<b>F8-7940</b>	H=55; d=12; D1=37,2; D2=38,4
Rubber Buffer, suspension	1.6 i 16V, 1.8 i 16V, 1.8 i 16V 4x4, 1.8 TD, 2.0 i 16V, 2.0 i 16V 4x4, 2.5 i 24V	<b>F8-8120</b>	
Protective Cap/Bellow, shock absorber	1.6 i 16V, 1.8 i 16V, 1.8 i 16V 4x4, 1.8 TD, 2.0 i 16V, 2.0 i 16V 4x4, 2.5 i 24V	<b>F8-8121</b>	
Control Arm-/Trailing Arm Bush	1.6 i 16V, 1.8 i 16V, 1.8 i 16V 4x4, 1.8 TD, 2.0 i 16V, 2.0 i 16V 4x4, 2.5 i 24V	<b>G9-633</b>	H1=28.2; H2=45.5; d=12; D=47.5
Control Arm-/Trailing Arm Bush	1.6 i 16V, 1.8 i 16V, 1.8 i 16V 4x4, 1.8 TD, 2.0 i 16V, 2.0 i 16V 4x4, 2.5 i 24V	<b>G9-634</b>	H1=25; H2=45; d=12; D=46
Bellow, steering	1.6 i 16V, 1.8 i 16V, 1.8 i 16V 4x4, 1.8 TD, 2.0 i 16V, 2.0 i 16V 4x4, 2.5 i 24V	<b>LM-10034S</b>	with clamps;  d1=17; d2=58; L [mm]=215
<b>MONDEO Saloon (GBP)</b>		<b>02/1993 → 08/1996</b>	
Dust Cover Kit, shock absorber	1.6 i 16V, 1.8 i 16V, 1.8 TD, 2.0 i 16V, 2.0 i 16V 4x4, 2.5 i 24V	<b>AK-735033</b>	
Dust Cover Kit, shock absorber	1.6 i 16V, 1.8 i 16V, 1.8 TD, 2.0 i 16V, 2.0 i 16V 4x4, 2.5 i 24V	<b>AK-735035</b>	
Control Arm-/Trailing Arm Bush	1.6 i 16V, 1.8 i 16V, 1.8 TD, 2.0 i 16V, 2.5 i 24V	<b>F8-5136</b>	H=46; d=12; D=60
Top Strut Mounting	1.6 i 16V, 1.8 i 16V, 1.8 TD, 2.0 i 16V, 2.0 i 16V 4x4, 2.5 i 24V	<b>F8-5503</b>	
Top Strut Mounting	1.6 i 16V, 1.8 i 16V, 1.8 TD, 2.0 i 16V, 2.0 i 16V 4x4, 2.5 i 24V	<b>F8-5504</b>	
Stabiliser Mounting	1.6 i 16V, 1.8 i 16V, 1.8 TD, 2.0 i 16V, 2.0 i 16V 4x4, 2.5 i 24V	<b>F8-6137</b>	d=19
Anti-Friction Bearing	1.6 i 16V, 1.8 i 16V, 1.8 TD, 2.0 i 16V, 2.0 i 16V 4x4, 2.5 i 24V	<b>F8-6262</b>	
Top Strut Mounting	1.6 i 16V, 1.8 i 16V, 1.8 TD, 2.0 i 16V, 2.0 i 16V 4x4, 2.5 i 24V	<b>F8-6308</b>	
Stabiliser Mounting	1.6 i 16V, 1.8 i 16V, 1.8 TD, 2.0 i 16V, 2.0 i 16V 4x4, 2.5 i 24V	<b>F8-6639</b>	d=16
Control Arm-/Trailing Arm Bush	1.6 i 16V, 1.8 4x4, 1.8 i 16V, 1.8 TD, 2.0 i 16V, 2.0 i 16V 4x4, 2.5 i 24V	<b>F8-6722</b>	H1=28; H2=35; d=12; D=36,5
Engine Mounting	1.6 i 16V, 1.8 i 16V, 2.0 i 16V, 2.5 i 24V	<b>F8-7031</b>	
Stabiliser Mounting	1.6 i 16V, 1.8 i 16V, 1.8 TD, 2.0 i 16V, 2.5 i 24V	<b>F8-7915</b>	
Mounting, axle beam	1.6 i 16V, 1.8 4x4, 1.8 i 16V, 1.8 TD, 2.0 i 16V, 2.0 i 16V 4x4, 2.5 i 24V	<b>F8-7940</b>	H=55; d=12; D1=37,2; D2=38,4
Rubber Buffer, suspension	1.6 i 16V, 1.8 i 16V, 1.8 TD, 2.0 i 16V, 2.0 i 16V 4x4, 2.5 i 24V	<b>F8-8120</b>	

<b>AK-735033</b>	<b>AK-735035</b>	<b>F8-5136</b>	<b>F8-5503</b>	<b>F8-5504</b>	<b>F8-6137</b>	<b>F8-6262</b>
Ref.Nr.: 1023326	Ref.Nr.:	Ref.Nr.: 95BG3A262AA	Ref.Nr.: 6807407	Ref.Nr.: 6799585	Ref.Nr.: 1128725	Ref.Nr.: 97BG-3K099-AA
<b>F8-6308</b>	<b>F8-6639</b>	<b>F8-6722</b>	<b>F8-7031</b>	<b>F8-7915</b>	<b>F8-7940</b>	<b>F8-8120</b>
Ref.Nr.: 98BG3K099AA	Ref.Nr.: 93BB4A037EA	Ref.Nr.: 6829045	Ref.Nr.: 97BB6P082AB	Ref.Nr.: 7144202	Ref.Nr.: 6829046	Ref.Nr.: 6708739
<b>F8-8121</b>	<b>G9-633</b>	<b>G9-634</b>	<b>LM-10034S</b>			
Ref.Nr.: 1023326	Ref.Nr.: 6790115	Ref.Nr.: 6870549	Ref.Nr.: 3904122			

Article Description



Article Nr.

Fitting Position



<b>MONDEO Saloon (GBP)</b>		<b>02/1993 → 08/1996</b>	
Protective Cap/Bellow, shock absorber	1.6 i 16V, 1.8 i 16V, 1.8 TD, 2.0 i 16V, 2.0 i 16V 4x4, 2.5 i 24V	<b>F8-8121</b>	
Control Arm-/Trailing Arm Bush	1.6 i 16V, 1.8 i 16V, 1.8 TD, 2.0 i 16V, 2.0 i 16V 4x4, 2.5 i 24V	<b>G9-633</b>	H1=28.2; H2=45.5; d=12; D=47.5
Control Arm-/Trailing Arm Bush	1.6 i 16V, 1.8 i 16V, 1.8 TD, 2.0 i 16V, 2.0 i 16V 4x4, 2.5 i 24V	<b>G9-634</b>	H1=25; H2=45; d=12; D=46
Bellow, steering	1.6 i 16V, 1.8 4x4, 1.8 i 16V, 1.8 TD, 2.0 i 16V, 2.0 i 16V 4x4, 2.5 i 24V	<b>LM-10034S</b>	with clamps;  d1=17; d2=58; L [mm]=215
<b>MONDEO Estate (BNP)</b>		<b>01/1993 → 08/1996</b>	
Dust Cover Kit, shock absorber	All Models	<b>AK-735033</b>	
Control Arm-/Trailing Arm Bush	1.6 i 16V, 1.8 i 16V, 1.8 TD, 2.0 i 16V, 2.5 i 24V	<b>F8-5136</b>	H=46; d=12; D=60
Top Strut Mounting	All Models	<b>F8-5504</b>	
Stabiliser Mounting	All Models	<b>F8-6137</b>	d=19
Anti-Friction Bearing	All Models	<b>F8-6262</b>	
Top Strut Mounting	All Models	<b>F8-6308</b>	
Stabiliser Mounting	All Models	<b>F8-6639</b>	d=16
Control Arm-/Trailing Arm Bush	All Models	<b>F8-6722</b>	H1=28; H2=35; d=12; D=36,5
Engine Mounting	1.6 i 16V, 1.8 i 16V, 2.0 i 16V, 2.5 i 24V	<b>F8-7031</b>	
Stabiliser Mounting	1.6 i 16V, 1.8 i 16V, 1.8 TD, 2.0 i 16V, 2.5 i 24V	<b>F8-7915</b>	
Mounting, axle beam	1.6 i 16V, 1.8 i 16V, 1.8 i 16V 4x4, 1.8 TD, 2.0 i 16V, 2.0 i 16V 4x4, 2.5 i 24V	<b>F8-7940</b>	H=55; d=12; D1=37,2; D2=38,4
Rubber Buffer, suspension	All Models	<b>F8-8120</b>	
Protective Cap/Bellow, shock absorber	All Models	<b>F8-8121</b>	
Control Arm-/Trailing Arm Bush	All Models	<b>G9-633</b>	H1=28.2; H2=45.5; d=12; D=47.5
Control Arm-/Trailing Arm Bush	All Models	<b>G9-634</b>	H1=25; H2=45; d=12; D=46
Bellow, steering	All Models	<b>LM-10034S</b>	with clamps;  d1=17; d2=58; L [mm]=215
<b>MONDEO Mk II (BAP)</b>		<b>08/1996 → 09/2000</b>	
Dust Cover Kit, shock absorber	All Models	<b>AK-735033</b>	
Dust Cover Kit, shock absorber	All Models	<b>AK-735035</b>	
Control Arm-/Trailing Arm Bush	1.6 i, 1.6 i 16V, 1.8 i, 1.8 TD, 2.0 i, 2.5 24V	<b>F8-5136</b>	H=46; d=12; D=60
Top Strut Mounting	All Models	<b>F8-5503</b>	
Top Strut Mounting	All Models	<b>F8-5504</b>	
Stabiliser Mounting	All Models	<b>F8-6137</b>	d=19

<b>AK-735033</b>	<b>AK-735035</b>	<b>F8-5136</b>	<b>F8-5503</b>	<b>F8-5504</b>	<b>F8-6137</b>	<b>F8-6262</b>
Ref.Nr.: 1023326	Ref.Nr.:	Ref.Nr.: 95BG3A262AA	Ref.Nr.: 6807407	Ref.Nr.: 6799585	Ref.Nr.: 1128725	Ref.Nr.: 97BG-3K099-AA
<b>F8-6308</b>	<b>F8-6639</b>	<b>F8-6722</b>	<b>F8-7031</b>	<b>F8-7915</b>	<b>F8-7940</b>	<b>F8-8120</b>
Ref.Nr.: 98BG3K099AA	Ref.Nr.: 93BB4A037EA	Ref.Nr.: 6829045	Ref.Nr.: 97BB6P082AB	Ref.Nr.: 7144202	Ref.Nr.: 6829046	Ref.Nr.: 6708739
<b>F8-8121</b>	<b>G9-633</b>	<b>G9-634</b>	<b>LM-10034S</b>			
Ref.Nr.: 1023326	Ref.Nr.: 6790115	Ref.Nr.: 6870549	Ref.Nr.: 3904122			

**Article Description****Article Nr.****Fitting Position****MONDEO Mk II (BAP)****08/1996 → 09/2000**

Anti-Friction Bearing	All Models		<b>F8-6262</b>		
Top Strut Mounting	All Models		<b>F8-6308</b>		
Spring Cap	All Models		<b>F8-6553</b>		
Locking ring	All Models		<b>F8-6554</b>		
Stabiliser Mounting	1.6 i, 1.6 i 16V, 1.8 i, 1.8 TD, 2.0 i, 2.5 24V		<b>F8-6639</b>		d=16
Control Arm-/Trailing Arm Bush	All Models		<b>F8-6722</b>		H1=28; H2=35; d=12; D=36,5
Engine Mounting	1.6 i, 1.8 i, 2.0 i, 2.5 24V, 2.5 ST 200		<b>F8-7031</b>		
Stabiliser Mounting	All Models		<b>F8-7915</b>		
Mounting, axle beam	All Models		<b>F8-7940</b>		H=55; d=12; D1=37,2; D2=38,4
Rubber Buffer, suspension	All Models		<b>F8-8120</b>		
Protective Cap/Bellow, shock absorber	All Models		<b>F8-8121</b>		
Control Arm-/Trailing Arm Bush	All Models		<b>G9-633</b>		H1=28.2; H2=45.5; d=12; D=47.5
Control Arm-/Trailing Arm Bush	All Models		<b>G9-634</b>		H1=25; H2=45; d=12; D=46
Bellow, steering	All Models	with clamps;	<b>LM-10034S</b>		d1=17; d2=58; L [mm]=215

**MONDEO Mk II Saloon (BFP)****08/1996 → 09/2000**

Dust Cover Kit, shock absorber	All Models		<b>AK-735033</b>		
Dust Cover Kit, shock absorber	All Models		<b>AK-735035</b>		
Control Arm-/Trailing Arm Bush	1.6 i, 1.6 i 16V, 1.8 i, 1.8 TD, 2.0 i, 2.5 24V		<b>F8-5136</b>		H=46; d=12; D=60
Top Strut Mounting	All Models		<b>F8-5503</b>		
Top Strut Mounting	All Models		<b>F8-5504</b>		
Stabiliser Mounting	All Models		<b>F8-6137</b>		d=19
Anti-Friction Bearing	All Models		<b>F8-6262</b>		
Top Strut Mounting	All Models		<b>F8-6308</b>		
Spring Cap	All Models		<b>F8-6553</b>		
Locking ring	All Models		<b>F8-6554</b>		
Stabiliser Mounting	All Models		<b>F8-6639</b>		d=16
Control Arm-/Trailing Arm Bush	All Models		<b>F8-6722</b>		H1=28; H2=35; d=12; D=36,5
Engine Mounting	1.6 i, 1.8 i, 2.0 i, 2.5 24V, 2.5 ST 200		<b>F8-7031</b>		
Stabiliser Mounting	All Models		<b>F8-7915</b>		
Mounting, axle beam	All Models		<b>F8-7940</b>		H=55; d=12; D1=37,2; D2=38,4
Rubber Buffer, suspension	All Models		<b>F8-8120</b>		

<b>AK-735033</b>	<b>AK-735035</b>	<b>F8-5136</b>	<b>F8-5503</b>	<b>F8-5504</b>	<b>F8-6137</b>	<b>F8-6262</b>
Ref.Nr.: 1023326	Ref.Nr.:	Ref.Nr.: 95BG3A262AA	Ref.Nr.: 6807407	Ref.Nr.: 6799585	Ref.Nr.: 1128725	Ref.Nr.: 97BG-3K099-AA
<b>F8-6308</b>	<b>F8-6553</b>	<b>F8-6554</b>	<b>F8-6639</b>	<b>F8-6722</b>	<b>F8-7031</b>	<b>F8-7915</b>
Ref.Nr.: 98BG3K099AA	Ref.Nr.: 1033283	Ref.Nr.: 6708751	Ref.Nr.: 93BB4A037EA	Ref.Nr.: 6829045	Ref.Nr.: 97BB6P082AB	Ref.Nr.: 7144202
<b>F8-7940</b>	<b>F8-8120</b>	<b>F8-8121</b>	<b>G9-633</b>	<b>G9-634</b>	<b>LM-10034S</b>	
Ref.Nr.: 6829046	Ref.Nr.: 6708739	Ref.Nr.: 1023326	Ref.Nr.: 6790115	Ref.Nr.: 6870549	Ref.Nr.: 3904122	

Article Description



Article Nr.

Fitting Position



<b>MONDEO Mk II Saloon (BFP)</b>			<b>08/1996 → 09/2000</b>	
Protective Cap/Bellow, shock absorber	All Models		<b>F8-8121</b>	
Control Arm-/Trailing Arm Bush	All Models		<b>G9-633</b>	H1=28.2; H2=45.5; d=12; D=47.5
Control Arm-/Trailing Arm Bush	All Models		<b>G9-634</b>	H1=25; H2=45; d=12; D=46
Bellow, steering	All Models	with clamps;	<b>LM-10034S</b>	d1=17; d2=58; L [mm]=215
<b>MONDEO Mk II Estate (BNP)</b>			<b>08/1996 → 09/2000</b>	
Dust Cover Kit, shock absorber	All Models		<b>AK-735033</b>	
Control Arm-/Trailing Arm Bush	1.6 i, 1.6 i 16V, 1.8 i, 1.8 TD, 2.0 i, 2.5 24V		<b>F8-5136</b>	H=46; d=12; D=60
Top Strut Mounting	All Models		<b>F8-5504</b>	
Stabiliser Mounting	All Models		<b>F8-6137</b>	d=19
Anti-Friction Bearing	All Models		<b>F8-6262</b>	
Top Strut Mounting	All Models		<b>F8-6308</b>	
Spring Cap	All Models		<b>F8-6553</b>	
Locking ring	All Models		<b>F8-6554</b>	
Stabiliser Mounting	1.6 i, 1.6 i 16V, 1.8 i, 1.8 TD, 2.0 i, 2.5 24V		<b>F8-6639</b>	d=16
Control Arm-/Trailing Arm Bush	All Models		<b>F8-6722</b>	H1=28; H2=35; d=12; D=36,5
Engine Mounting	1.6 i, 1.8 i, 2.0 i, 2.5 24V, 2.5 ST 200		<b>F8-7031</b>	
Stabiliser Mounting	All Models		<b>F8-7915</b>	
Mounting, axle beam	All Models		<b>F8-7940</b>	H=55; d=12; D1=37,2; D2=38,4
Rubber Buffer, suspension	All Models		<b>F8-8120</b>	
Protective Cap/Bellow, shock absorber	All Models		<b>F8-8121</b>	
Control Arm-/Trailing Arm Bush	All Models		<b>G9-633</b>	H1=28.2; H2=45.5; d=12; D=47.5
Control Arm-/Trailing Arm Bush	All Models		<b>G9-634</b>	H1=25; H2=45; d=12; D=46
Bellow, steering	All Models	with clamps;	<b>LM-10034S</b>	d1=17; d2=58; L [mm]=215
<b>MONDEO Mk III (B5Y)</b>			<b>10/2000 → 03/2007</b>	
Dust Cover Kit, shock absorber	1.8 16V, 1.8 SCi, 2.0 16V, 2.0 16V DI / TDDi / TDCi, 2.0 16V TDDi / TDCi, 2.0 TDCi, 2.5 V6 24V		<b>AK-735077</b>	
Dust Cover Kit, shock absorber	1.8 16V, 1.8 SCi, 2.0 16V, 2.0 16V DI / TDDi / TDCi, 2.0 16V TDDi / TDCi, 2.0 TDCi, 2.2 TDCi, 2.5 V6 24V, 3.0 V6 24V		<b>AK-735084</b>	
Alternator Freewheel Clutch	1.8 16V, 1.8 SCi, 2.0 16V		<b>F5-1034</b>	
Alternator Freewheel Clutch	1.8 16V	CHBA; Manufacturer Restriction: Denso	<b>F5-1059</b>	

<b>AK-735033</b>	<b>AK-735077</b>	<b>AK-735084</b>	<b>F5-1034</b>	<b>F5-1059</b>	<b>F8-5136</b>	<b>F8-5504</b>
Ref.Nr.: 1023326	Ref.Nr.: 1105883	Ref.Nr.: 1105883	Ref.Nr.:	Ref.Nr.: 3M5T-10300-VC	Ref.Nr.: 95BG3A262AA	Ref.Nr.: 6799585
<b>F8-6137</b>	<b>F8-6262</b>	<b>F8-6308</b>	<b>F8-6553</b>	<b>F8-6554</b>	<b>F8-6639</b>	<b>F8-6722</b>
Ref.Nr.: 1128725	Ref.Nr.: 97BG-3K099-AA	Ref.Nr.: 98BG3K099AA	Ref.Nr.: 1033283	Ref.Nr.: 6708751	Ref.Nr.: 93BB4A037EA	Ref.Nr.: 6829045
<b>F8-7031</b>	<b>F8-7915</b>	<b>F8-7940</b>			<b>G9-633</b>	<b>G9-634</b>
Ref.Nr.: 97BB6P082AB	Ref.Nr.: 7144202	Ref.Nr.: 6829046	Ref.Nr.: 6708739	Ref.Nr.: 1023326	Ref.Nr.: 6790115	Ref.Nr.: 6870549

**Article Description****Article Nr.****Fitting Position****MONDEO Mk III (B5Y) 10/2000 → 03/2007**

Alternator Freewheel Clutch	1.8 SCi	Manufacturer Restriction: Denso	<b>F5-1059</b>		
Alternator Freewheel Clutch	2.0 16V DI / TDDi / TDCi, 2.5 V6 24V		<b>F5-1063</b>		
Alternator Freewheel Clutch	2.5 V6 24V, 3.0 V6 24V, ST220		<b>F5-1066</b>		
Top Strut Mounting	1.8 16V, 1.8 SCi, 2.0 16V, 2.0 16V DI / TDDi / TDCi, 2.0 16V TDDi / TDCi, 2.0 TDCi, 2.2 TDCi, 2.5 V6 24V, 3.0 V6 24V, ST220		<b>F8-5408</b>		
Control Arm-/Trailing Arm Bush	1.8 16V, 1.8 SCi, 2.0 16V, 2.0 16V DI / TDDi / TDCi, 2.0 16V TDDi / TDCi, 2.0 TDCi, 2.2 TDCi, 2.5 V6 24V, 3.0 V6 24V		<b>F8-6157</b>		d=12; L=69
Control Arm-/Trailing Arm Bush	1.8 16V, 1.8 SCi, 2.0 16V, 2.0 16V DI / TDDi / TDCi, 2.0 16V TDDi / TDCi, 2.0 TDCi, 2.2 TDCi, 2.5 V6 24V, 3.0 V6 24V	Operating Mode: Hydraulic	<b>F8-6158</b>		d=13; D=84; D1=75
Anti-Friction Bearing	1.8 16V, 1.8 SCi, 2.0 16V, 2.0 16V DI / TDDi / TDCi, 2.0 16V TDDi / TDCi, 2.0 TDCi, 2.2 TDCi, 2.5 V6 24V, 3.0 V6 24V, ST220		<b>F8-6510</b>		d=35; D=107; Thick. [mm]=37
Mounting, axle beam	1.8 16V, 1.8 SCi, 2.0 16V, 2.0 16V DI / TDDi / TDCi, 2.0 16V TDDi / TDCi, 2.0 TDCi, 2.2 TDCi, 2.5 V6 24V, 3.0 V6 24V, ST220		<b>F8-6640</b>		
Mounting, axle beam	1.8 16V, 1.8 SCi, 2.0 16V, 2.0 16V DI / TDDi / TDCi, 2.0 16V TDDi / TDCi, 2.0 TDCi, 2.2 TDCi, 2.5 V6 24V, 3.0 V6 24V, ST220		<b>F8-6641</b>		
Top Strut Mounting	1.8 16V, 1.8 SCi, 2.0 16V, 2.0 16V DI / TDDi / TDCi, 2.0 16V TDDi / TDCi, 2.0 TDCi, 2.5 V6 24V, 3.0 V6 24V, ST220		<b>F8-7102</b>		
Top Strut Mounting	1.8 16V, 1.8 SCi, 2.0 16V, 2.0 16V DI / TDDi / TDCi, 2.0 16V TDDi / TDCi, 2.0 TDCi, 2.2 TDCi, 2.5 V6 24V, 3.0 V6 24V		<b>F8-7455</b>		
Belt Pulley, crankshaft	2.0 16V DI / TDDi / TDCi, 2.0 16V TDDi / TDCi, 2.0 TDCi, 2.2 TDCi	Number of Ribs: 5; Parameter: 6PK	<b>F8-7650</b>		D=167; Thick. [mm]=37
Engine Mounting	2.0 16V DI / TDDi / TDCi, 2.0 16V TDDi / TDCi, 2.0 TDCi, 2.2 TDCi		<b>F8-8177</b>		
Engine Mounting	1.8 16V, 2.0 16V, 2.0 16V DI / TDDi / TDCi, 2.0 16V TDDi / TDCi, 2.0 TDCi, 2.5 V6 24V	12/2001 →	<b>F8-8200</b>		
Engine Mounting	2.0 TDCi, 2.2 TDCi, 3.0 V6 24V, ST220		<b>F8-8200</b>		

**MONDEO Mk III Saloon (B4Y) 10/2000 → 03/2007**

Dust Cover Kit, shock absorber	1.8 16V, 1.8 SCi, 2.0 16V, 2.0 16V DI / TDDi / TDCi, 2.0 16V TDDi / TDCi, 2.0 TDCi, 2.5 V6 24V		<b>AK-735077</b>		
Dust Cover Kit, shock absorber	1.8 16V, 1.8 SCi, 2.0 16V, 2.0 16V DI / TDDi / TDCi, 2.0 16V TDDi / TDCi, 2.0 TDCi, 2.2 TDCi, 2.5 V6 24V, 3.0 V6 24V		<b>AK-735084</b>		
Alternator Freewheel Clutch	1.8 16V, 1.8 SCi, 2.0 16V		<b>F5-1034</b>		
Alternator Freewheel Clutch	1.8 16V	CHBA; Manufacturer Restriction: Denso	<b>F5-1059</b>		
Alternator Freewheel Clutch	1.8 SCi	Manufacturer Restriction: Denso	<b>F5-1059</b>		

<b>AK-735077</b>	<b>AK-735084</b>	<b>F5-1034</b>	<b>F5-1059</b>	<b>F5-1063</b>	<b>F5-1066</b>	<b>F8-5408</b>
Ref.Nr.: 1105883	Ref.Nr.: 1105883	Ref.Nr.:	Ref.Nr.: 3M5T-10300-VC	Ref.Nr.:	Ref.Nr.:	Ref.Nr.: 1S7W3K155AF
<b>F8-6157</b>	<b>F8-6158</b>	<b>F8-6510</b>	<b>F8-6640</b>	<b>F8-6641</b>	<b>F8-7102</b>	<b>F8-7455</b>
Ref.Nr.: 1311416S1	Ref.Nr.: 1311416S2	Ref.Nr.: 1115177	Ref.Nr.: 1404977	Ref.Nr.: 1404976	Ref.Nr.: 1115177	Ref.Nr.: 1S7118198AF
<b>F8-7650</b>	<b>F8-8177</b>	<b>F8-8200</b>				
Ref.Nr.: 1S7Q6B319AB	Ref.Nr.: 1332838	Ref.Nr.: 1152896				

Article Description



Article Nr.

Fitting Position



<b>MONDEO Mk III Saloon (B4Y)</b>		<b>10/2000 → 03/2007</b>	
Alternator Freewheel Clutch	2.5 V6 24V, 3.0 V6 24V, ST220		<b>F5-1066</b>
Top Strut Mounting	1.8 16V, 1.8 SCi, 2.0 16V, 2.0 16V DI / TDDi / TDCi, 2.0 16V TDDi / TDCi, 2.0 TDCi, 2.2 TDCi, 2.5 V6 24V, 3.0 V6 24V, ST220		<b>F8-5408</b>
Control Arm-/Trailing Arm Bush	1.8 16V, 1.8 SCi, 2.0 16V, 2.0 16V DI / TDDi / TDCi, 2.0 16V TDDi / TDCi, 2.0 TDCi, 2.2 TDCi, 2.5 V6 24V, 3.0 V6 24V		<b>F8-6157</b>
Control Arm-/Trailing Arm Bush	1.8 16V, 1.8 SCi, 2.0 16V, 2.0 16V DI / TDDi / TDCi, 2.0 16V TDDi / TDCi, 2.0 TDCi, 2.2 TDCi, 2.5 V6 24V, 3.0 V6 24V	Operating Mode: Hydraulic 	<b>F8-6158</b>
Anti-Friction Bearing	1.8 16V, 1.8 SCi, 2.0 16V, 2.0 16V DI / TDDi / TDCi, 2.0 16V TDDi / TDCi, 2.0 TDCi, 2.2 TDCi, 2.5 V6 24V, 3.0 V6 24V, ST220		<b>F8-6510</b>
Mounting, axle beam	1.8 16V, 1.8 SCi, 2.0 16V, 2.0 16V DI / TDDi / TDCi, 2.0 16V TDDi / TDCi, 2.0 TDCi, 2.2 TDCi, 2.5 V6 24V, 3.0 V6 24V, ST220		<b>F8-6640</b>
Mounting, axle beam	1.8 16V, 1.8 SCi, 2.0 16V, 2.0 16V DI / TDDi / TDCi, 2.0 16V TDDi / TDCi, 2.0 TDCi, 2.2 TDCi, 2.5 V6 24V, 3.0 V6 24V, ST220		<b>F8-6641</b>
Top Strut Mounting	1.8 16V, 1.8 SCi, 2.0 16V, 2.0 16V DI / TDDi / TDCi, 2.0 16V TDDi / TDCi, 2.0 TDCi, 2.2 TDCi, 2.5 V6 24V, 3.0 V6 24V, ST220		<b>F8-7102</b>
Top Strut Mounting	1.8 16V, 1.8 SCi, 2.0 16V, 2.0 16V DI / TDDi / TDCi, 2.0 16V TDDi / TDCi, 2.0 TDCi, 2.2 TDCi, 2.5 V6 24V, 3.0 V6 24V		<b>F8-7455</b>
Belt Pulley, crankshaft	2.0 16V DI / TDDi / TDCi, 2.0 16V TDDi / TDCi, 2.0 TDCi, 2.2 TDCi	Number of Ribs: 5; Parameter: 6PK	<b>F8-7650</b>
Stabiliser Mounting	1.8 16V, 1.8 SCi, 2.0 16V, 2.0 16V DI / TDDi / TDCi, 2.0 16V TDDi / TDCi, 2.0 TDCi, 2.2 TDCi, 2.5 V6 24V, 3.0 V6 24V, ST220		<b>F8-7903</b>
Engine Mounting	2.0 16V DI / TDDi / TDCi, 2.0 16V TDDi / TDCi, 2.0 TDCi, 2.2 TDCi		<b>F8-8177</b>
Engine Mounting	1.8 16V, 2.0 16V, 2.0 16V DI / TDDi / TDCi, 2.0 16V TDDi / TDCi, 2.0 TDCi, 2.2 TDCi, 3.0 V6 24V, ST220		<b>F8-8200</b>
Engine Mounting	2.5 V6 24V	12/2001 →	<b>F8-8200</b>
<b>MONDEO Mk III Estate (BWY)</b>		<b>10/2000 → 03/2007</b>	
Dust Cover Kit, shock absorber	1.8 16V, 1.8 SCi, 2.0 16V, 2.0 16V DI / TDDi / TDCi, 2.0 16V TDDi / TDCi, 2.0 TDCi, 2.5 V6 24V		<b>AK-735077</b>
Alternator Freewheel Clutch	1.8 16V, 1.8 SCi, 2.0 16V		<b>F5-1034</b>
Alternator Freewheel Clutch	1.8 16V	CHBA; Manufacturer Restriction: Denso	<b>F5-1059</b>
Alternator Freewheel Clutch	1.8 SCi	Manufacturer Restriction: Denso	<b>F5-1059</b>
Alternator Freewheel Clutch	2.5 V6 24V		<b>F5-1063</b>
Alternator Freewheel Clutch	2.5 V6 24V, 3.0 V6 24V, ST220		<b>F5-1066</b>

<b>AK-735077</b>	<b>F5-1034</b>	<b>F5-1059</b>	<b>F5-1063</b>	<b>F5-1066</b>	<b>F8-5408</b>	<b>F8-6157</b>
Ref.Nr.: 1105883	Ref.Nr.:	Ref.Nr.: 3M5T-10300-VC	Ref.Nr.:	Ref.Nr.:	Ref.Nr.: 1S7W3K155AF	Ref.Nr.: 1311416S1
<b>F8-6158</b>	<b>F8-6510</b>	<b>F8-6640</b>	<b>F8-6641</b>	<b>F8-7102</b>	<b>F8-7455</b>	<b>F8-7650</b>
Ref.Nr.: 1311416S2	Ref.Nr.: 1115177	Ref.Nr.: 1404977	Ref.Nr.: 1404976	Ref.Nr.: 1115177	Ref.Nr.: 1S7118198AF	Ref.Nr.: 1S7Q6B319AB
<b>F8-7903</b>	<b>F8-8177</b>	<b>F8-8200</b>				
Ref.Nr.: 1124418	Ref.Nr.: 1332838	Ref.Nr.: 1152896				

**Article Description****Article Nr.****Fitting Position**

<b>MONDEO Mk III Estate (BWY)</b>		<b>10/2000 → 03/2007</b>	
Top Strut Mounting	1.8 16V, 1.8 SCi, 2.0 16V, 2.0 16V DI / TDDi / TDCi, 2.0 16V TDDi / TDCi, 2.0 TDCi, 2.2 TDCi, 2.5 V6 24V, 3.0 V6 24V, ST220		<b>F8-5408</b>
Control Arm-/Trailing Arm Bush	1.8 16V, 1.8 SCi, 2.0 16V, 2.0 16V DI / TDDi / TDCi, 2.0 16V TDDi / TDCi, 2.0 TDCi, 2.2 TDCi, 2.5 V6 24V, 3.0 V6 24V		<b>F8-6157</b>
Control Arm-/Trailing Arm Bush	1.8 16V, 1.8 SCi, 2.0 16V, 2.0 16V DI / TDDi / TDCi, 2.0 16V TDDi / TDCi, 2.0 TDCi, 2.2 TDCi, 2.5 V6 24V, 3.0 V6 24V	Operating Mode: Hydraulic 	<b>F8-6158</b>
Anti-Friction Bearing	1.8 16V, 1.8 SCi, 2.0 16V, 2.0 16V DI / TDDi / TDCi, 2.0 16V TDDi / TDCi, 2.0 TDCi, 2.2 TDCi, 2.5 V6 24V, 3.0 V6 24V, ST220		<b>F8-6510</b>
Top Strut Mounting	1.8 16V, 1.8 SCi, 2.0 16V, 2.0 16V DI / TDDi / TDCi, 2.0 16V TDDi / TDCi, 2.0 TDCi, 2.2 TDCi, 2.5 V6 24V, 3.0 V6 24V, ST220		<b>F8-7102</b>
Belt Pulley, crankshaft	2.0 16V DI / TDDi / TDCi, 2.0 16V TDDi / TDCi, 2.0 TDCi, 2.2 TDCi	Number of Ribs: 5; Parameter: 6PK	<b>F8-7650</b>
Engine Mounting	2.0 16V DI / TDDi / TDCi, 2.0 16V TDDi / TDCi, 2.0 TDCi, 2.2 TDCi		<b>F8-8177</b>
Engine Mounting	1.8 16V, 2.0 16V, 2.0 16V DI / TDDi / TDCi, 2.0 16V TDDi / TDCi, 2.0 TDCi, 2.2 TDCi, 3.0 V6 24V, ST220		<b>F8-8200</b>
Engine Mounting	2.5 V6 24V	12/2001 →	<b>F8-8200</b>
<b>MONDEO IV (BA7)</b>		<b>03/2007 → 09/2014</b>	
Dust Cover Kit, shock absorber	All Models		<b>AK-735192</b>
Dust Cover Kit, shock absorber	1.6 Ti, 1.8 TDCi, 2.0, 2.0 Flexifuel, 2.0 TDCi, 2.2 TDCi, 2.3, 2.5		<b>AK-735193</b>
Alternator Freewheel Clutch	2.0 TDCi, 2.2 TDCi		<b>F5-1046</b>
Alternator Freewheel Clutch	1.8 TDCi		<b>F5-1057</b>
Alternator Freewheel Clutch	2.0, 2.0 Flexifuel, 2.0 LPG		<b>F5-1075</b>
Alternator Freewheel Clutch	2.0 EcoBoost, 2.0 SCTi		<b>F5-1134</b>
Belt Pulley, crankshaft	1.8 TDCi	Number of Ribs: 6	<b>F8-6399</b>
Top Strut Mounting	All Models		<b>F8-7606</b>
Anti-Friction Bearing	All Models		<b>F8-7607</b>
Top Strut Mounting	All Models		<b>F8-7608</b>
Control Arm-/Trailing Arm Bush	All Models		<b>F8-7877</b>
Control Arm-/Trailing Arm Bush	All Models		<b>F8-7878</b>
Control Arm-/Trailing Arm Bush	All Models		<b>F8-8074</b>
Control Arm-/Trailing Arm Bush	All Models		<b>F8-8075</b>

<b>AK-735192</b>	<b>AK-735193</b>	<b>F5-1046</b>	<b>F5-1057</b>	<b>F5-1075</b>	<b>F5-1134</b>	<b>F8-5408</b>
Ref.Nr.: 1474352	Ref.Nr.: 1464268	Ref.Nr.: 30667687	Ref.Nr.: 5M5Q-10344-AA	Ref.Nr.: 30667610	Ref.Nr.: 31285489	Ref.Nr.: 1S7W3K155AF
<b>F8-6157</b>	<b>F8-6158</b>	<b>F8-6399</b>	<b>F8-6510</b>	<b>F8-7102</b>	<b>F8-7606</b>	<b>F8-7607</b>
Ref.Nr.: 1311416S1	Ref.Nr.: 1311416S2	Ref.Nr.: 1151 392	Ref.Nr.: 1115177	Ref.Nr.: 1115177	Ref.Nr.: 1734710	Ref.Nr.: 1510474
<b>F8-7608</b>	<b>F8-7650</b>	<b>F8-7877</b>	<b>F8-7878</b>	<b>F8-8074</b>	<b>F8-8075</b>	<b>F8-8177</b>
Ref.Nr.: 6G91-3K099-NB	Ref.Nr.: 1S7Q6B319AB	Ref.Nr.: 1865033	Ref.Nr.: 31 277 755	Ref.Nr.: 7G9J-3A262-AB	Ref.Nr.: 1507181	Ref.Nr.: 1332838

Article Description



Article Nr.

Fitting Position



### MONDEO IV Saloon (BA7)

03/2007 → 09/2014

Dust Cover Kit, shock absorber	1.6 Ti, 1.8 TDCi, 2.0, 2.0 Flexifuel, 2.0 LPG, 2.0 TDCi, 2.2 TDCi, 2.3, 2.5	ST	AK-735192			
Dust Cover Kit, shock absorber	1.6 Ti, 1.8 TDCi, 2.0, 2.0 Flexifuel, 2.0 TDCi, 2.2 TDCi, 2.3, 2.5		AK-735193			
Alternator Freewheel Clutch	2.0 TDCi, 2.2 TDCi		F5-1046			
Alternator Freewheel Clutch	1.8 TDCi		F5-1057			
Alternator Freewheel Clutch	2.0, 2.0 Flexifuel, 2.0 LPG		F5-1075			
Belt Pulley, crankshaft	1.8 TDCi	Number of Ribs: 6	F8-6399			
Top Strut Mounting	1.6 Ti, 1.8 TDCi, 2.0, 2.0 Flexifuel, 2.0 LPG, 2.0 TDCi, 2.2 TDCi, 2.3, 2.5		F8-7606			
Anti-Friction Bearing	1.6 Ti, 1.8 TDCi, 2.0, 2.0 Flexifuel, 2.0 LPG, 2.0 TDCi, 2.2 TDCi, 2.3, 2.5		F8-7607			
Top Strut Mounting	1.6 Ti, 1.8 TDCi, 2.0, 2.0 Flexifuel, 2.0 LPG, 2.0 TDCi, 2.2 TDCi, 2.3, 2.5		F8-7608			
Control Arm-/Trailing Arm Bush	1.6 Ti, 1.8 TDCi, 2.0, 2.0 Flexifuel, 2.0 LPG, 2.0 TDCi, 2.2 TDCi, 2.3, 2.5		F8-7877			
Control Arm-/Trailing Arm Bush	1.6 Ti, 1.8 TDCi, 2.0, 2.0 Flexifuel, 2.0 LPG, 2.0 TDCi, 2.2 TDCi, 2.3, 2.5		F8-7878			
Control Arm-/Trailing Arm Bush	All Models		F8-8074			
Control Arm-/Trailing Arm Bush	All Models		F8-8075			

### MONDEO IV Turnier (BA7)

03/2007 → 09/2014

Dust Cover Kit, shock absorber	All Models	ST	AK-735192			
Dust Cover Kit, shock absorber	1.6 EcoBoost, 1.6 TDCi, 1.6 Ti, 1.8 TDCi, 2.0, 2.0 EcoBoost, 2.0 Flexifuel, 2.0 LPG, 2.0 SCTi, 2.0 TDCi, 2.2 TDCi, 2.5		AK-735202			
Alternator Freewheel Clutch	2.0 TDCi, 2.2 TDCi		F5-1046			
Alternator Freewheel Clutch	1.8 TDCi		F5-1057			
Alternator Freewheel Clutch	2.0, 2.0 Flexifuel, 2.0 LPG		F5-1075			
Alternator Freewheel Clutch	2.0 EcoBoost, 2.0 SCTi		F5-1134			
Belt Pulley, crankshaft	1.8 TDCi	Number of Ribs: 6	F8-6399			
Top Strut Mounting	All Models		F8-7606			
Anti-Friction Bearing	All Models		F8-7607			
Top Strut Mounting	All Models		F8-7608			
Control Arm-/Trailing Arm Bush	All Models		F8-7877			
Control Arm-/Trailing Arm Bush	All Models		F8-7878			
Control Arm-/Trailing Arm Bush	All Models		F8-8074			

<b>AK-735192</b>	<b>AK-735193</b>	<b>AK-735202</b>	<b>F5-1046</b>	<b>F5-1057</b>	<b>F5-1075</b>	<b>F5-1134</b>
Ref.Nr.: 1474352	Ref.Nr.: 1464268	Ref.Nr.: 1441213	Ref.Nr.: 30667687	Ref.Nr.: 5M5Q-10344-AA	Ref.Nr.: 30667610	Ref.Nr.: 31285489
<b>F8-6399</b>	<b>F8-7606</b>	<b>F8-7607</b>	<b>F8-7608</b>	<b>F8-7877</b>	<b>F8-7878</b>	<b>F8-8074</b>
Ref.Nr.: 1151 392	Ref.Nr.: 1734710	Ref.Nr.: 1510474	Ref.Nr.: 6G91-3K099-NB	Ref.Nr.: 1865033	Ref.Nr.: 31 277 755	Ref.Nr.: 7G9J-3A262-AB
<b>F8-8075</b>						
Ref.Nr.: 1507181						



**Article Description****Article Nr.****Fitting Position**

<b>MONDEO IV Turnier (BA7)</b>		<b>03/2007 → 09/2014</b>	
Control Arm-/Trailing Arm Bush	All Models	F8-8075	
<b>ORION (AFD)</b>		<b>07/1983 → 03/1986</b>	
Dust Cover Kit, shock absorber	All Models	AK-735005	
Dust Cover Kit, shock absorber	All Models	AK-735097	
Anti-Friction Bearing	All Models	F8-3018	H=11; d1=12; d2=20; D=42.2
Anti-Friction Bearing	All Models	F8-3020	d=12; d1=12; d2=20; D=54; W=10
Anti-Friction Bearing	All Models	F8-3027	H=27; d=12; D1=95; D2=130
Bellow, steering	All Models	F8-5038	
Control Arm-/Trailing Arm Bush	All Models	F8-5075	H=51; d=10; D=33
Stabiliser Mounting	1.3, 1.6	F8-5080	d=22
Top Strut Mounting	All Models	F8-5507	
Top Strut Mounting	1.3, 1.6, 1.6 i	F8-5880	
Top Strut Mounting	1.6 D	F8-5880	
Engine Mounting	1.6 D	F8-6952	
Control Arm-/Trailing Arm Bush	All Models	G9-500	H=20; d=16; D=46
Control Arm-/Trailing Arm Bush	All Models	G9-522	H=51; d=10; D1=33; D2=38
<b>ORION Mk II (AFF)</b>		<b>12/1985 → 07/1990</b>	
Dust Cover Kit, shock absorber	1.3, 1.4, 1.4 CAT, 1.6, 1.6 D, 1.6 i, 1.6 i CAT, 1.8 D	AK-735005	
Dust Cover Kit, shock absorber	1.3, 1.4, 1.4 CAT, 1.6, 1.6 D, 1.6 i, 1.6 i CAT, 1.8 D	AK-735097	
Anti-Friction Bearing	1.4, 1.4 CAT, 1.6, 1.6 D, 1.6 i, 1.6 i CAT, 1.8 D	F8-3018	H=11; d1=12; d2=20; D=42.2
Anti-Friction Bearing	1.3, 1.4, 1.4 CAT, 1.6, 1.6 D, 1.6 i, 1.6 i CAT, 1.8 D	F8-3020	d=12; d1=12; d2=20; D=54; W=10
Anti-Friction Bearing	1.4, 1.4 CAT, 1.6, 1.6 D, 1.6 i, 1.6 i CAT, 1.8 D	F8-3027	H=27; d=12; D1=95; D2=130
Bellow, steering	1.3, 1.4, 1.4 CAT, 1.6, 1.6 D, 1.6 i, 1.6 i CAT	F8-5038	
Stabiliser Mounting	1.4, 1.4 CAT, 1.6, 1.6 D, 1.6 i, 1.6 i CAT, 1.8 D	F8-5070	d=24
Control Arm-/Trailing Arm Bush	1.3, 1.4, 1.4 CAT, 1.6, 1.6 D, 1.6 i, 1.6 i CAT, 1.8 D	F8-5075	H=51; d=10; D=33
Stabiliser Mounting	1.3, 1.4	F8-5080	d=22
Stabiliser Mounting	1.4, 1.4 CAT, 1.6, 1.6 D, 1.6 i, 1.6 i CAT, 1.8 D	F8-5080	d=22
Top Strut Mounting	1.3, 1.4, 1.4 CAT, 1.6, 1.6 D, 1.6 i, 1.6 i CAT, 1.8 D	F8-5507	
Top Strut Mounting	1.3, 1.4, 1.6, 1.6 D	F8-5880	
Top Strut Mounting	1.4, 1.4 CAT, 1.6 i, 1.8 D	F8-5880	
Engine Mounting	1.8 D	F8-6492	
Engine Mounting	1.6 D	F8-6506	

<b>AK-735005</b>	<b>AK-735097</b>	<b>F8-3018</b>	<b>F8-3020</b>	<b>F8-3027</b>	<b>F8-5038</b>	<b>F8-5070</b>
Ref.Nr.:	Ref.Nr.:	Ref.Nr.: 6112404	Ref.Nr.: 85BB3K099AA	Ref.Nr.: 90170695	Ref.Nr.: 6127744	Ref.Nr.: 1634901
<b>F8-5075</b>	<b>F8-5080</b>	<b>F8-5507</b>	<b>F8-5880</b>	<b>F8-6492</b>	<b>F8-6506</b>	<b>F8-6952</b>
Ref.Nr.: 1619120	Ref.Nr.: 1634900	Ref.Nr.: 6119999	Ref.Nr.: 6150276	Ref.Nr.: 1 661 786	Ref.Nr.: 6203710	Ref.Nr.: 6185027
<b>F8-8075</b>	<b>G9-500</b>	<b>G9-522</b>				
Ref.Nr.: 1507181	Ref.Nr.: 6107025	Ref.Nr.: 1619120				

Article Description



Article Nr.

Fitting Position



<b>ORION Mk II (AFF)</b>		<b>12/1985 → 07/1990</b>	
Engine Mounting	1.8 D	<b>F8-6506</b>	⊕ ⊕
Engine Mounting	1.8 D	<b>F8-6953</b>	⊕
Control Arm-/Trailing Arm Bush	1.3, 1.4, 1.4 CAT, 1.6, 1.6 D, 1.6 i, 1.6 i CAT, 1.8 D	<b>G9-500</b>	⊕ ⊕ ⊕ H=20; d=16; D=46
Control Arm-/Trailing Arm Bush	1.3, 1.4, 1.4 CAT, 1.6, 1.6 D, 1.6 i, 1.6 i CAT, 1.8 D	<b>G9-522</b>	⊕ ⊕ ⊕ H=51; d=10; D1=33; D2=38
Control Arm-/Trailing Arm Bush	1.4	for OE: 1637184, 1637185	<b>G9-522</b> ⊕ ⊕ ⊕ H=51; d=10; D1=33; D2=38
<b>ORION Mk III (GAL)</b>		<b>07/1990 → 12/1993</b>	
Dust Cover Kit, shock absorber	1.8 i 16V	<b>AK-735005</b>	⊕ ⊕ ⊕
Dust Cover Kit, shock absorber	1.3, 1.4, 1.6, 1.6 i, 1.6 i 16V, 1.8 D, 1.8 i 16V, 1.8 TD	<b>AK-735017</b>	⊕ ⊕ ⊕
Anti-Friction Bearing	1.3, 1.4, 1.6, 1.6 i, 1.6 i 16V, 1.8 D, 1.8 i 16V, 1.8 TD	<b>F8-3018</b>	⊕ ⊕ ⊕ H=11; d1=12; d2=20; D=42.2
Anti-Friction Bearing	1.3, 1.4, 1.6 i 16V, 1.8 D, 1.8 i 16V, 1.8 TD	<b>F8-3020</b>	⊕ ⊕ ⊕ d=12; d1=12; d2=20; D=54; W=10
Anti-Friction Bearing	1.3, 1.4, 1.6 i 16V, 1.8 D, 1.8 i 16V, 1.8 TD	<b>F8-3027</b>	⊕ ⊕ ⊕ H=27; d=12; D1=95; D2=130
Top Strut Mounting	1.3, 1.4, 1.6, 1.6 i, 1.6 i 16V, 1.8 D, 1.8 i 16V, 1.8 TD	<b>F8-5522</b>	⊕ ⊕ ⊕
Engine Mounting	1.8 D, 1.8 TD	<b>F8-5561</b>	⊕
Stabiliser Mounting	1.3, 1.4, 1.6, 1.6 i, 1.6 i 16V, 1.8 D, 1.8 i 16V, 1.8 TD	<b>F8-6034</b>	⊕ ⊕ ⊕ d=16
Top Strut Mounting	1.3, 1.4, 1.6, 1.6 i, 1.6 i 16V, 1.8 D, 1.8 i 16V, 1.8 TD	<b>F8-6307</b>	⊕
Suspension Strut Mounting	1.3, 1.4, 1.6, 1.6 i, 1.6 i 16V, 1.8 D, 1.8 i 16V, 1.8 TD	<b>F8-6356</b>	⊕
Engine Mounting	1.6 i 16V, 1.8 D, 1.8 i 16V, 1.8 TD	<b>F8-6503</b>	⊕
Control Arm-/Trailing Arm Bush	1.3, 1.4, 1.6, 1.6 i, 1.6 i 16V, 1.8 D, 1.8 i 16V, 1.8 TD	<b>G9-585</b>	⊕ ⊕ ⊕ H1=46; H2=25; d=12; D=46
Control Arm-/Trailing Arm Bush	1.3, 1.4, 1.6, 1.6 i, 1.6 i 16V, 1.8 D, 1.8 i 16V, 1.8 TD	<b>G9-586</b>	⊕ ⊕ ⊕ ↓ H1=27; H2=46; d=12; D1=54; D2=62
<b>P 100 Mk II</b>		<b>10/1987 → 12/1992</b>	
Top Strut Mounting	All Models	<b>F8-5507</b>	⊕ ⊕ ⊕
Control Arm-/Trailing Arm Bush	All Models	<b>G9-501</b>	⊕ ⊕ ⊕ H=23; d=16; D1=49; D2=65
Control Arm-/Trailing Arm Bush	All Models	<b>G9-501S</b>	⊕ ⊕ ⊕ H=23; d=16; D1=49; D2=65
<b>PUMA (EC_)</b>		<b>03/1997 → 06/2002</b>	
Dust Cover Kit, shock absorber	All Models	<b>AK-735082</b>	⊕
Top Strut Mounting	All Models	<b>F8-5409</b>	⊕ ⊕ ⊕ d=22; D1=99; D2=106
Top Strut Mounting	All Models	<b>F8-5410</b>	⊕ ⊕ ⊕
Engine Mounting	1.4 16V, 1.6 16V, 1.7 16V	<b>F8-5411</b>	⊕
Anti-Friction Bearing	1.7 16V	<b>F8-5413</b>	⊕ ⊕ ⊕
Stabiliser Mounting	All Models	<b>F8-6034</b>	⊕ ⊕ ⊕ d=16

<b>AK-735005</b>	<b>AK-735017</b>	<b>AK-735082</b>	<b>F8-3018</b>	<b>F8-3020</b>	<b>F8-3027</b>	<b>F8-5409</b>
Ref.Nr.:	Ref.Nr.:	Ref.Nr.:	Ref.Nr.: 6112404	Ref.Nr.: 85BB3K099AA	Ref.Nr.: 90170695	Ref.Nr.: 1039001
<b>F8-5410</b>	<b>F8-5411</b>	<b>F8-5413</b>	<b>F8-5507</b>	<b>F8-5522</b>	<b>F8-5561</b>	<b>F8-6034</b>
Ref.Nr.: 1E0028012A	Ref.Nr.: 1014899	Ref.Nr.: 1002513	Ref.Nr.: 6119999	Ref.Nr.: 6495311	Ref.Nr.: 6 160 229	Ref.Nr.: 7102392
<b>F8-6074</b>	<b>F8-6307</b>	<b>F8-6356</b>	<b>F8-6503</b>	<b>F8-6506</b>	<b>F8-6953</b>	<b>G9-500</b>
Ref.Nr.: 1016439	Ref.Nr.: 6112404	Ref.Nr.: 89FB-5599-AC	Ref.Nr.: 1 040 404	Ref.Nr.: 6203710	Ref.Nr.: 6178901	Ref.Nr.: 6107025

**Article Description****Article Nr.****Fitting Position**

<b>PUMA (EC_)</b>			<b>03/1997 → 06/2002</b>		
Mounting, axle beam	All Models		<b>F8-6074</b>		H1=70; H2=55; D=63.2
Top Strut Mounting	All Models		<b>F8-6312</b>		
Spring Cap	All Models		<b>F8-6557</b>		
Engine Mounting	1.4 16V, 1.6 16V, 1.7 16V		<b>F8-8115</b>		
Control Arm-/Trailing Arm Bush	All Models		<b>G9-662</b>		H1=44; H2=62; d=12; D1=24; D2=37
Control Arm-/Trailing Arm Bush	All Models		<b>G9-663</b>		H=50; d=12; D=66
Bellow, steering	1.4 16V, 1.7 16V, ST 160	with clamps	<b>LM-10007S</b>		d1=14; d2=56; L [mm]=175
<b>RANGER (TKE)</b>			<b>04/2011 →</b>		
Alternator Freewheel Clutch	2.2 TDCi, 2.2 TDCi 4x4, 2.2 TDi, 3.2 TDCi 4x4		<b>F5-1101</b>		
<b>GRANADA Mk III (GAE, GGE)</b>			<b>04/1985 → 09/1994</b>		
Dust Cover Kit, shock absorber	1.8, 2.0, 2.0 i, 2.4 i, 2.4 i CAT, 2.5 D, 2.5 TD, 2.8 i, 2.9 i, 2.9 i 24V, 2.9 i CAT		<b>AK-735034</b>		
Anti-Friction Bearing	1.8, 2.0, 2.0 i, 2.4 i, 2.4 i CAT, 2.5 D, 2.5 TD, 2.8 i, 2.8 i 4x4, 2.9 i, 2.9 i 24V, 2.9 i 4x4, 2.9 i CAT		<b>F8-3018</b>		H=11; d1=12; d2=20; D=42.2
Mounting, axle beam	All Models		<b>F8-5204</b>		d=14
Control Arm-/Trailing Arm Bush	1.8, 2.0, 2.0 i, 2.4 i, 2.5 D, 2.9 i, 2.9 i CAT	02/1989 →	<b>G9-501</b>		H=23; d=16; D1=49; D2=65
Control Arm-/Trailing Arm Bush	2.0, 2.0 i, 2.4 i, 2.4 i CAT, 2.5 TD, 2.8 i, 2.8 i 4x4, 2.9 i 24V, 2.9 i 4x4		<b>G9-501</b>		H=23; d=16; D1=49; D2=65
Control Arm-/Trailing Arm Bush	1.8, 2.0, 2.0 i, 2.4 i, 2.5 D, 2.9 i, 2.9 i CAT	02/1989 →	<b>G9-501S</b>		H=23; d=16; D1=49; D2=65
Control Arm-/Trailing Arm Bush	2.0, 2.0 i, 2.4 i, 2.4 i CAT, 2.5 TD, 2.8 i, 2.8 i 4x4, 2.9 i 24V, 2.9 i 4x4		<b>G9-501S</b>		H=23; d=16; D1=49; D2=65
Control Arm-/Trailing Arm Bush	All Models		<b>G9-524</b>		H=52; d=12.1; D1=31.5; D2=40
Bellow, steering	1.8	1.8 HC; with clamps;	<b>LM-10027S</b>		d1=11; d2=48; L [mm]=220
Bellow, steering	2.0	2.0 HC; with clamps;	<b>LM-10027S</b>		d1=11; d2=48; L [mm]=220
Bellow, steering	2.0 i	2.0 EFI; with clamps;	<b>LM-10027S</b>		d1=11; d2=48; L [mm]=220
Bellow, steering	2.0 i	2.0 HC EFI; with clamps;	<b>LM-10027S</b>		d1=11; d2=48; L [mm]=220
Bellow, steering	2.0 i	2.0 LC EFI; with clamps;	<b>LM-10027S</b>		d1=11; d2=48; L [mm]=220
Bellow, steering	2.4 i	2.4 EFI; with clamps;	<b>LM-10027S</b>		d1=11; d2=48; L [mm]=220
Bellow, steering	2.5 D	2.5 NA; with clamps;	<b>LM-10027S</b>		d1=11; d2=48; L [mm]=220
Bellow, steering	2.5 TD	; with clamps;	<b>LM-10027S</b>		d1=11; d2=48; L [mm]=220

<b>AK-735034</b>	<b>F5-1101</b>	<b>F8-3018</b>	<b>F8-5204</b>	<b>F8-6074</b>	<b>F8-6312</b>	<b>F8-6557</b>
Ref.Nr.:	Ref.Nr.: 27415-0L020	Ref.Nr.: 6112404	Ref.Nr.: 6094239	Ref.Nr.: 1016439	Ref.Nr.: 1E003438X	Ref.Nr.: 7350848
<b>F8-8115</b>	<b>G9-501</b>	<b>G9-501S</b>	<b>G9-524</b>	<b>G9-662</b>	<b>G9-663</b>	<b>LM-10007S</b>
Ref.Nr.: 1021267	Ref.Nr.: 5021729	Ref.Nr.: 6122507	Ref.Nr.: 1632679	Ref.Nr.: 1E0034153A	Ref.Nr.: 1063372	Ref.Nr.: 94FB-3K661-AC
<b>LM-10027S</b>						
Ref.Nr.: 6128736						

Article Description



Article Nr.

Fitting Position



<b>GRANADA Mk III (GAE, GGE)</b>			<b>04/1985 → 09/1994</b>		
Bellow, steering	2.8 i, 2.8 i 4x4	2.8 HC EFI; with clamps;	<b>LM-10027S</b>		d1=11; d2=48; L [mm]=220
Bellow, steering	2.9 i, 2.9 i 24V, 2.9 i 4x4	2.9 EFI; with clamps;	<b>LM-10027S</b>		d1=11; d2=48; L [mm]=220
Bellow, steering	2.9 i, 2.9 i CAT	2.9 MC EFI; with clamps;	<b>LM-10027S</b>		d1=11; d2=48; L [mm]=220
Bellow, steering	1.8, 2.0, 2.0 i, 2.4 i, 2.5 D, 2.5 TD, 2.8 i, 2.9 i, 2.9 i 24V, 2.9 i CAT	with clamps;	<b>LM-10044S</b>		d1=10; d2=36.5; L [mm]=200
<b>GRANADA Mk III Saloon (GGE)</b>			<b>09/1986 → 12/1994</b>		
Dust Cover Kit, shock absorber	1.9, 2.0 i, 2.4 i, 2.5 D, 2.5 TD, 2.9 i, 2.9 i 24V		<b>AK-735034</b>		
Anti-Friction Bearing	2.0 i, 2.4 i, 2.5 TD, 2.9 i, 2.9 i 24V		<b>F8-3018</b>		H=11; d1=12; d2=20; D=42.2
Mounting, axle beam	2.0 i, 2.4 i, 2.5 D, 2.5 TD, 2.9 i, 2.9 i 24V, 2.9 i 4x4		<b>F8-5204</b>		d=14
Control Arm-/Trailing Arm Bush	2.0 i, 2.5 D, 2.5 TD, 2.9 i 24V, 2.9 i 4x4		<b>G9-501</b>		H=23; d=16; D1=49; D2=65
Control Arm-/Trailing Arm Bush	2.4 i, 2.9 i	02/1989 →	<b>G9-501</b>		H=23; d=16; D1=49; D2=65
Control Arm-/Trailing Arm Bush	2.0 i, 2.5 D, 2.5 TD, 2.9 i 24V, 2.9 i 4x4		<b>G9-501S</b>		H=23; d=16; D1=49; D2=65
Control Arm-/Trailing Arm Bush	2.4 i, 2.9 i	02/1989 →	<b>G9-501S</b>		H=23; d=16; D1=49; D2=65
Control Arm-/Trailing Arm Bush	2.0 i, 2.4 i, 2.5 D, 2.5 TD, 2.9 i, 2.9 i 24V, 2.9 i 4x4		<b>G9-524</b>		H=52; d=12.1; D1=31.5; D2=40
Bellow, steering	2.0	2.0 HC; with clamps;	<b>LM-10027S</b>		d1=11; d2=48; L [mm]=220
Bellow, steering	2.0 i	2.0 EFI; with clamps;	<b>LM-10027S</b>		d1=11; d2=48; L [mm]=220
Bellow, steering	2.4 i	2.4 EFI; with clamps;	<b>LM-10027S</b>		d1=11; d2=48; L [mm]=220
Bellow, steering	2.5 TD	with clamps;	<b>LM-10027S</b>		d1=11; d2=48; L [mm]=220
Bellow, steering	2.9 i	2.9 MC EFI; with clamps;	<b>LM-10027S</b>		d1=11; d2=48; L [mm]=220
Bellow, steering	2.9 i 24V	2.9 EFI; with clamps;	<b>LM-10027S</b>		d1=11; d2=48; L [mm]=220
Bellow, steering	2.9 i 4x4	2.9 MC, 2.9 MC EFI; with clamps;	<b>LM-10027S</b>		d1=11; d2=48; L [mm]=220
Bellow, steering	2.0 i, 2.4 i, 2.5 TD, 2.9 i, 2.9 i 24V	with clamps;	<b>LM-10044S</b>		d1=10; d2=36.5; L [mm]=200
<b>GRANADA Mk III Estate (GGE)</b>			<b>05/1988 → 09/1994</b>		
Dust Cover Kit, shock absorber	2.0 i, 2.4 i, 2.5 TD, 2.9 24V, 2.9 i, 2.9 i 4x4		<b>AK-735034</b>		
Anti-Friction Bearing	2.0 i, 2.4 i, 2.5 TD, 2.9 24V, 2.9 i		<b>F8-3018</b>		H=11; d1=12; d2=20; D=42.2
Mounting, axle beam	2.0 i, 2.4 i, 2.5 TD, 2.9 24V, 2.9 i, 2.9 i 4x4		<b>F8-5204</b>		d=14
Control Arm-/Trailing Arm Bush	2.0 i, 2.4 i, 2.5 TD, 2.9 24V, 2.9 i, 2.9 i 4x4		<b>G9-501</b>		H=23; d=16; D1=49; D2=65





Article Description

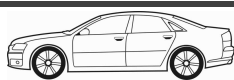

Article Nr.

Fitting Position



<b>GRANADA Mk III Estate (GGE)</b>				<b>05/1988 → 09/1994</b>	
Control Arm-/Trailing Arm Bush	2.0 i, 2.4 i, 2.5 TD, 2.9 24V, 2.9 i, 2.9 i 4x4		<b>G9-501S</b>		H=23; d=16; D1=49; D2=65
Control Arm-/Trailing Arm Bush	2.0 i, 2.4 i, 2.5 TD, 2.9 24V, 2.9 i, 2.9 i 4x4		<b>G9-524</b>		H=52; d=12.1; D1=31.5; D2=40
Bellow, steering	2.0 i	2.0 EFI; with clamps;	<b>LM-10027S</b>		d1=11; d2=48; L [mm]=220
Bellow, steering	2.4 i	2.4 EFI; with clamps;	<b>LM-10027S</b>		d1=11; d2=48; L [mm]=220
Bellow, steering	2.5 TD	with clamps;	<b>LM-10027S</b>		d1=11; d2=48; L [mm]=220
Bellow, steering	2.9 i	2.9 MC EFI; with clamps;	<b>LM-10027S</b>		d1=11; d2=48; L [mm]=220
Bellow, steering	2.0 i, 2.4 i, 2.5 TD, 2.9 24V, 2.9 i	with clamps;	<b>LM-10044S</b>		d1=10; d2=36.5; L [mm]=200
<b>SCORPIO Mk II (GFR, GGR)</b>				<b>10/1994 → 08/1998</b>	
Mounting, axle beam	All Models		<b>F8-5204</b>		d=14
Stabiliser Mounting	2.0 i, 2.0 i 16V, 2.5 TD, 2.9 i, 2.9 i 24V		<b>F8-6137</b>		d=19
Anti-Friction Bearing	All Models		<b>F8-6262</b>		
<b>SCORPIO Mk II Estate (GNR, GGR)</b>				<b>10/1994 → 08/1998</b>	
Mounting, axle beam	All Models		<b>F8-5204</b>		d=14
Stabiliser Mounting	2.0 i, 2.0 i 16V, 2.5 TD, 2.9 i, 2.9 i 24V		<b>F8-6137</b>		d=19
Anti-Friction Bearing	All Models		<b>F8-6262</b>		
<b>SIERRA Hatchback (GBC)</b>				<b>08/1982 → 12/1986</b>	
Dust Cover Kit, shock absorber	1.3, 1.6, 1.8, 2.0, 2.0 i, 2.3, 2.3 D, 2.8 XR4i		<b>AK-735011</b>		
Dust Cover Kit, shock absorber	2.8 XR4i	06/1984 →	<b>AK-735011</b>		
Dust Cover Kit, shock absorber	1.3, 1.6, 1.8, 2.0, 2.0 i, 2.3, 2.3 D, 2.8 i XR 4x4, 2.8 XR 4x4, 2.8 XR4i		<b>AK-735149</b>		
Anti-Friction Bearing	1.3, 1.6, 1.8, 2.0, 2.0 i, 2.3, 2.3 D, 2.8 XR 4x4, 2.8 XR4i		<b>F8-3018</b>		H=11; d1=12; d2=20; D=42.2
Anti-Friction Bearing	1.3, 1.6, 2.0, 2.3, 2.3 D, 2.8 XR4i	10/1984 →	<b>F8-3020</b>		d=12; d1=12; d2=20; D=54; W=10
Anti-Friction Bearing	1.6, 1.8, 2.0, 2.0 i, 2.8 XR 4x4, 2.8 XR4i		<b>F8-3020</b>		d=12; d1=12; d2=20; D=54; W=10
Anti-Friction Bearing	1.3, 1.6, 1.8, 2.0, 2.0 i, 2.3, 2.3 D, 2.8 XR 4x4, 2.8 XR4i		<b>F8-3027</b>		H=27; d=12; D1=95; D2=130
Control Arm-/Trailing Arm Bush	1.3		<b>F8-5075</b>		H=51; d=10; D=33
Control Arm-/Trailing Arm Bush	1.6, 1.8, 2.0, 2.0 i, 2.3, 2.3 D, 2.8 XR4i		<b>F8-5075</b>		H=51; d=10; D=33
Mounting, axle beam	1.3, 1.6, 1.8, 2.0, 2.0 i, 2.3, 2.3 D, 2.8 i XR 4x4, 2.8 XR 4x4, 2.8 XR4i		<b>F8-5204</b>		d=14
Top Strut Mounting	1.3, 1.6, 1.8, 2.0, 2.0 i, 2.3, 2.3 D, 2.8 i XR 4x4, 2.8 XR 4x4, 2.8 XR4i		<b>F8-5507</b>		
Top Strut Mounting	1.3, 1.6, 2.0, 2.3, 2.3 D, 2.8 XR4i	10/1984 →;	<b>F8-5880</b>		
Top Strut Mounting	1.6, 1.8, 2.0, 2.0 i, 2.8 XR 4x4		<b>F8-5880</b>		

<b>AK-735011</b>	<b>AK-735149</b>	<b>F8-3018</b>	<b>F8-3020</b>	<b>F8-3027</b>	<b>F8-5075</b>	<b>F8-5204</b>
Ref.Nr.:	Ref.Nr.: 6176933	Ref.Nr.: 6112404	Ref.Nr.: 85BB3K099AA	Ref.Nr.: 90170695	Ref.Nr.: 1619120	Ref.Nr.: 6094239
<b>F8-5507</b>	<b>F8-5880</b>	<b>F8-6137</b>	<b>F8-6262</b>	<b>G9-501</b>	<b>G9-501S</b>	<b>G9-524</b>
Ref.Nr.: 6119999	Ref.Nr.: 6150276	Ref.Nr.: 1128725	Ref.Nr.: 97BG-3K099-AA	Ref.Nr.: 5021729	Ref.Nr.: 6122507	Ref.Nr.: 1632679
<b>LM-10027S</b>	<b>LM-10044S</b>					
Ref.Nr.: 6128736	Ref.Nr.: 1619061					

Article Description



Article Nr.

Fitting Position



<b>SIERRA Hatchback (GBC)</b>			<b>08/1982 → 12/1986</b>		
Control Arm-/Trailing Arm Bush	1.3, 1.6, 1.8, 2.0, 2.0 i, 2.3, 2.3 D, 2.8 i XR 4x4, 2.8 XR 4x4, 2.8 XR4i		<b>G9-501</b>		H=23; d=16; D1=49; D2=65
Control Arm-/Trailing Arm Bush	1.3, 1.6, 1.8, 2.0, 2.0 i, 2.3, 2.3 D, 2.8 i XR 4x4, 2.8 XR 4x4, 2.8 XR4i		<b>G9-501S</b>		H=23; d=16; D1=49; D2=65
Control Arm-/Trailing Arm Bush	1.3, 1.6, 1.8, 2.0, 2.0 i, 2.3, 2.3 D, 2.8 XR4i		<b>G9-522</b>		H=51; d=10; D1=33; D2=38
Control Arm-/Trailing Arm Bush	1.6, 2.8 XR4i		<b>G9-522</b>		H=51; d=10; D1=33; D2=38
Control Arm-/Trailing Arm Bush	2.8 i XR 4x4, 2.8 XR 4x4		<b>G9-524</b>		H=52; d=12.1; D1=31.5; D2=40
Bellow, steering	1.3, 1.6, 2.0, 2.3 D	with clamps;	<b>LM-10027S</b>		d1=11; d2=48; L [mm]=220
Bellow, steering	1.8, 2.3	; ; with clamps; ;	<b>LM-10027S</b>		d1=11; d2=48; L [mm]=220
Bellow, steering	2.0 i	; ; ; ; 2.0 EFI; with clamps; ;	<b>LM-10027S</b>		d1=11; d2=48; L [mm]=220
Bellow, steering	2.8 XR 4x4, 2.8 XR4i	; ; ; ; 2.8 EFI; with clamps; ;	<b>LM-10027S</b>		d1=11; d2=48; L [mm]=220
Bellow, steering	2.8 XR4i	; ; ; ; 2.8 MFI; with clamps; ;	<b>LM-10027S</b>		d1=11; d2=48; L [mm]=220
Bellow, steering	1.3, 1.6, 1.8, 2.0, 2.0 i, 2.3, 2.3 D, 2.8 XR4i	with clamps;	<b>LM-10044S</b>		d1=10; d2=36.5; L [mm]=200
<b>SIERRA Estate (BNC)</b>			<b>08/1982 → 12/1986</b>		
Dust Cover Kit, shock absorber	1.6, 1.8, 2.0, 2.3, 2.3 D		<b>AK-735011</b>		
Dust Cover Kit, shock absorber	All Models		<b>AK-735149</b>		
Anti-Friction Bearing	1.6, 1.8, 2.0, 2.3, 2.3 D, 2.8 XR4i		<b>F8-3018</b>		H=11; d1=12; d2=20; D=42.2
Anti-Friction Bearing	1.6, 2.0, 2.3, 2.3 D, 2.8 XR4i	10/1984 →	<b>F8-3020</b>		d=12; d1=12; d2=20; D=54; W=10
Anti-Friction Bearing	1.8, 2.0, 2.8 XR4i		<b>F8-3020</b>		d=12; d1=12; d2=20; D=54; W=10
Anti-Friction Bearing	1.6, 1.8, 2.0, 2.3, 2.3 D, 2.8 XR4i		<b>F8-3027</b>		H=27; d=12; D1=95; D2=130
Control Arm-/Trailing Arm Bush	1.6, 1.8, 2.0, 2.3, 2.3 D, 2.8 XR4i		<b>F8-5075</b>		H=51; d=10; D=33
Mounting, axle beam	All Models		<b>F8-5204</b>		d=14
Top Strut Mounting	All Models		<b>F8-5507</b>		
Top Strut Mounting	1.6, 2.0, 2.3, 2.3 D, 2.8 XR4i	10/1984 →;	<b>F8-5880</b>		
Top Strut Mounting	1.8, 2.0		<b>F8-5880</b>		
Control Arm-/Trailing Arm Bush	All Models		<b>G9-501</b>		H=23; d=16; D1=49; D2=65
Control Arm-/Trailing Arm Bush	All Models		<b>G9-501S</b>		H=23; d=16; D1=49; D2=65
Control Arm-/Trailing Arm Bush	1.6, 1.8, 2.0, 2.3, 2.3 D, 2.8 XR4i		<b>G9-522</b>		H=51; d=10; D1=33; D2=38
Control Arm-/Trailing Arm Bush	2.8 XR4i		<b>G9-522</b>		H=51; d=10; D1=33; D2=38

<b>AK-735011</b>	<b>AK-735149</b>	<b>F8-3018</b>	<b>F8-3020</b>	<b>F8-3027</b>	<b>F8-5075</b>	<b>F8-5204</b>
Ref.Nr.:	Ref.Nr.: 6176933	Ref.Nr.: 6112404	Ref.Nr.: 85BB3K099AA	Ref.Nr.: 90170695	Ref.Nr.: 1619120	Ref.Nr.: 6094239
<b>F8-5507</b>	<b>F8-5880</b>	<b>G9-501</b>	<b>G9-501S</b>	<b>G9-522</b>	<b>G9-524</b>	<b>LM-10027S</b>
Ref.Nr.: 6119999	Ref.Nr.: 6150276	Ref.Nr.: 5021729	Ref.Nr.: 6122507	Ref.Nr.: 1619120	Ref.Nr.: 1632679	Ref.Nr.: 6128736
<b>LM-10044S</b>						
Ref.Nr.: 1619061						

**Article Description****Article Nr.****Fitting Position**

<b>SIERRA Estate (BNC)</b>			<b>08/1982 → 12/1986</b>		
Control Arm-/Trailing Arm Bush	2.8 i 4x4		<b>G9-524</b>		H=52; d=12.1; D1=31.5; D2=40
Bellow, steering	1.6, 2.0, 2.3 D	with clamps;	<b>LM-10027S</b>		d1=11; d2=48; L [mm]=220
Bellow, steering	1.8, 2.3	; ; with clamps; ;	<b>LM-10027S</b>		d1=11; d2=48; L [mm]=220
Bellow, steering	2.8 XR4i	; ; ;  2.8 EFI; with clamps; ;	<b>LM-10027S</b>		d1=11; d2=48; L [mm]=220
Bellow, steering	1.6, 1.8, 2.0, 2.3, 2.3 D, 2.8 XR4i	with clamps;	<b>LM-10044S</b>		d1=10; d2=36.5; L [mm]=200
<b>SIERRA (GBG, GB4)</b>			<b>01/1987 → 02/1993</b>		
Dust Cover Kit, shock absorber	1.6, 1.6 i, 1.8, 1.8 TD, 2.0, 2.0 i, 2.0 i CAT, 2.3 D, 2.9 i		<b>AK-735011</b>		
Dust Cover Kit, shock absorber	1.6, 1.6 i, 1.8, 1.8 TD, 2.0, 2.0 4x4, 2.0 i, 2.0 i CAT, 2.0 i DOHC, 2.3 D, 2.8 i, 2.9 4x4, 2.9 i		<b>AK-735149</b>		
Anti-Friction Bearing	1.6, 1.6 i, 1.8, 1.8 TD, 2.0, 2.0 4x4, 2.0 i, 2.0 i CAT, 2.3 D, 2.9 4x4, 2.9 i		<b>F8-3018</b>		H=11; d1=12; d2=20; D=42.2
Anti-Friction Bearing	1.6, 1.6 i, 1.8, 1.8 TD, 2.0, 2.0 4x4, 2.0 i, 2.0 i CAT, 2.3 D, 2.8 i, 2.9 4x4, 2.9 i		<b>F8-3020</b>		d=12; d1=12; d2=20; D=54; W=10
Anti-Friction Bearing	1.6, 1.6 i, 1.8, 1.8 TD, 2.0, 2.0 4x4, 2.0 i, 2.0 i CAT, 2.3 D, 2.9 4x4, 2.9 i		<b>F8-3027</b>		H=27; d=12; D1=95; D2=130
Control Arm-/Trailing Arm Bush	1.6, 1.6 i, 1.8, 1.8 TD, 2.0, 2.0 i, 2.0 i CAT, 2.3 D, 2.9 i		<b>F8-5075</b>		H=51; d=10; D=33
Mounting, axle beam	1.6, 1.6 i, 1.8, 1.8 TD, 2.0, 2.0 4x4, 2.0 i, 2.0 i CAT, 2.3 D, 2.8 i, 2.9 4x4, 2.9 i		<b>F8-5204</b>		d=14
Top Strut Mounting	1.6, 1.6 i, 1.8, 1.8 TD, 2.0, 2.0 4x4, 2.0 i, 2.0 i CAT, 2.3 D, 2.8 i, 2.9 4x4, 2.9 i		<b>F8-5507</b>		
Top Strut Mounting	1.6, 1.6 i, 1.8, 1.8 TD, 2.0, 2.0 4x4, 2.0 i, 2.0 i CAT, 2.0 i DOHC, 2.3 D, 2.8 i, 2.9 4x4, 2.9 i		<b>F8-5880</b>		
Control Arm-/Trailing Arm Bush	1.6, 1.6 i, 1.8, 1.8 TD, 2.0, 2.0 4x4, 2.0 i, 2.0 i CAT, 2.3 D, 2.8 i, 2.9 4x4, 2.9 i		<b>G9-501</b>		H=23; d=16; D1=49; D2=65
Control Arm-/Trailing Arm Bush	1.6, 1.6 i, 1.8, 1.8 TD, 2.0, 2.0 4x4, 2.0 i, 2.0 i CAT, 2.3 D, 2.8 i, 2.9 4x4, 2.9 i		<b>G9-501S</b>		H=23; d=16; D1=49; D2=65
Control Arm-/Trailing Arm Bush	1.6, 1.6 i, 1.8, 1.8 TD, 2.0, 2.0 4x4, 2.0 i, 2.0 i CAT, 2.3 D, 2.8 i, 2.9 4x4, 2.9 i		<b>G9-522</b>		H=51; d=10; D1=33; D2=38
Control Arm-/Trailing Arm Bush	2.0 4x4, 2.9 4x4		<b>G9-524</b>		H=52; d=12.1; D1=31.5; D2=40
Bellow, steering	1.6, 2.0, 2.3 D	with clamps;	<b>LM-10027S</b>		d1=11; d2=48; L [mm]=220
Bellow, steering	1.8	; ; ;  1.8 HC; with clamps; ;	<b>LM-10027S</b>		d1=11; d2=48; L [mm]=220
Bellow, steering	1.8 TD	; ; ; with clamps; ;	<b>LM-10027S</b>		d1=11; d2=48; L [mm]=220
Bellow, steering	2.0 i	; ; ;  2.0 HC EFI; with clamps; ;	<b>LM-10027S</b>		d1=11; d2=48; L [mm]=220
Bellow, steering	2.0 i CAT	; ; ;  2.0 LC EFI; with clamps; ;	<b>LM-10027S</b>		d1=11; d2=48; L [mm]=220
Bellow, steering	2.0 i DOHC	; ; ;  2.0 EFI; with clamps; ;	<b>LM-10027S</b>		d1=11; d2=48; L [mm]=220

<b>AK-735011</b>	<b>AK-735149</b>	<b>F8-3018</b>	<b>F8-3020</b>	<b>F8-3027</b>	<b>F8-5075</b>	<b>F8-5204</b>
Ref.Nr.:	Ref.Nr.: 6176933	Ref.Nr.: 6112404	Ref.Nr.: 85BB3K099AA	Ref.Nr.: 90170695	Ref.Nr.: 1619120	Ref.Nr.: 6094239
<b>F8-5507</b>	<b>F8-5880</b>	<b>G9-501</b>	<b>G9-501S</b>	<b>G9-522</b>	<b>G9-524</b>	<b>LM-10027S</b>
Ref.Nr.: 6119999	Ref.Nr.: 6150276	Ref.Nr.: 5021729	Ref.Nr.: 6122507	Ref.Nr.: 1619120	Ref.Nr.: 1632679	Ref.Nr.: 6128736
<b>LM-10044S</b>						
Ref.Nr.: 1619061						

Article Description

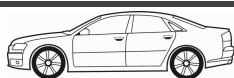

Article Nr.

Fitting Position



<b>SIERRA (GBG, GB4)</b>				<b>01/1987 → 02/1993</b>	
Bellow, steering	2.0, 2.0 i	2.0 HC; with clamps;	<b>LM-10027S</b>		d1=11; d2=48; L [mm]=220
Bellow, steering	2.8 i	2.8 EFI; with clamps;	<b>LM-10027S</b>		d1=11; d2=48; L [mm]=220
Bellow, steering	2.9 4x4, 2.9 i	2.9 EFI; with clamps;	<b>LM-10027S</b>		d1=11; d2=48; L [mm]=220
Bellow, steering	1.6, 1.6 i, 1.8, 1.8 TD, 2.0, 2.0 i, 2.0 i CAT, 2.3 D, 2.9 i	with clamps;	<b>LM-10044S</b>		d1=10; d2=36.5; L [mm]=200
<b>SIERRA Hatchback (GBC, GBG)</b>				<b>01/1987 → 02/1993</b>	
Dust Cover Kit, shock absorber	1.6, 1.6 i, 1.8, 1.8 TD, 2.0, 2.0 i, 2.0 i CAT, 2.3 D, 2.9 i		<b>AK-735011</b>		
Dust Cover Kit, shock absorber	1.6, 1.6 i, 1.8, 1.8 TD, 2.0, 2.0 16V Cosworth 4x4, 2.0 16V Cosworth 4x4 CAT, 2.0 i, 2.0 i CAT, 2.0 DOHC, 2.0 RS Cosworth, 2.3 D, 2.8 i, 2.8 i XR 4x4, 2.9 i, 2.9 i XR 4x4		<b>AK-735149</b>		
Anti-Friction Bearing	1.6, 1.6 i, 1.8, 1.8 TD, 2.0, 2.0 16V Cosworth 4x4, 2.0 16V Cosworth 4x4 CAT, 2.0 i, 2.0 i CAT, 2.0 RS Cosworth, 2.3 D, 2.8 i, 2.8 i XR 4x4, 2.9 i, 2.9 i XR 4x4		<b>F8-3018</b>		H=11; d1=12; d2=20; D=42.2
Anti-Friction Bearing	1.6, 1.6 i, 1.8, 1.8 TD, 2.0, 2.0 16V Cosworth 4x4, 2.0 16V Cosworth 4x4 CAT, 2.0 i, 2.0 i CAT, 2.0 RS Cosworth, 2.3 D, 2.8 i, 2.8 i XR 4x4, 2.9 i, 2.9 i XR 4x4		<b>F8-3020</b>		d=12; d1=12; d2=20; D=54; W=10
Anti-Friction Bearing	1.6, 1.6 i, 1.8, 1.8 TD, 2.0, 2.0 16V Cosworth 4x4, 2.0 16V Cosworth 4x4 CAT, 2.0 i, 2.0 i CAT, 2.0 RS Cosworth, 2.3 D, 2.8 i, 2.8 i XR 4x4, 2.9 i, 2.9 i XR 4x4		<b>F8-3027</b>		H=27; d=12; D1=95; D2=130
Control Arm-/Trailing Arm Bush	1.6, 1.6 i, 1.8, 1.8 TD, 2.0, 2.0 16V Cosworth 4x4, 2.0 16V Cosworth 4x4 CAT, 2.0 i, 2.0 i CAT, 2.0 RS Cosworth, 2.3 D, 2.8 i, 2.8 i XR 4x4, 2.9 i		<b>F8-5075</b>		H=51; d=10; D=33
Mounting, axle beam	1.6, 1.6 i, 1.8, 1.8 TD, 2.0, 2.0 16V Cosworth 4x4, 2.0 16V Cosworth 4x4 CAT, 2.0 i, 2.0 i CAT, 2.0 RS Cosworth, 2.3 D, 2.8 i, 2.8 i XR 4x4, 2.9 i, 2.9 i XR 4x4		<b>F8-5204</b>		d=14
Top Strut Mounting	1.6, 1.6 i, 1.8, 1.8 TD, 2.0, 2.0 16V Cosworth 4x4, 2.0 16V Cosworth 4x4 CAT, 2.0 i, 2.0 i CAT, 2.0 RS Cosworth, 2.3 D, 2.8 i, 2.8 i XR 4x4, 2.9 i, 2.9 i XR 4x4		<b>F8-5507</b>		
Top Strut Mounting	1.6, 1.6 i, 1.8, 1.8 TD, 2.0, 2.0 16V Cosworth 4x4 CAT, 2.0 i, 2.0 i CAT, 2.0 DOHC, 2.0 RS Cosworth, 2.3 D, 2.8 i, 2.8 i XR 4x4, 2.9 i, 2.9 i XR 4x4		<b>F8-5880</b>		
Control Arm-/Trailing Arm Bush	1.6, 1.6 i, 1.8, 1.8 TD, 2.0, 2.0 16V Cosworth 4x4, 2.0 16V Cosworth 4x4 CAT, 2.0 i, 2.0 i CAT, 2.0 RS Cosworth, 2.3 D, 2.8 i, 2.8 i XR 4x4, 2.9 i, 2.9 i XR 4x4		<b>G9-501</b>		H=23; d=16; D1=49; D2=65
Control Arm-/Trailing Arm Bush	1.6, 1.6 i, 1.8, 1.8 TD, 2.0, 2.0 16V Cosworth 4x4, 2.0 16V Cosworth 4x4 CAT, 2.0 i, 2.0 i CAT, 2.0 RS Cosworth, 2.3 D, 2.8 i, 2.8 i XR 4x4, 2.9 i, 2.9 i XR 4x4		<b>G9-501S</b>		H=23; d=16; D1=49; D2=65
Control Arm-/Trailing Arm Bush	1.6, 1.6 i, 1.8, 1.8 TD, 2.0, 2.0 16V Cosworth 4x4, 2.0 16V Cosworth 4x4 CAT, 2.0 i, 2.0 i CAT, 2.0 RS Cosworth, 2.3 D, 2.8 i, 2.8 i XR 4x4, 2.9 i, 2.9 i XR 4x4		<b>G9-522</b>		H=51; d=10; D1=33; D2=38
Control Arm-/Trailing Arm Bush	2.0 16V Cosworth 4x4, 2.0 16V Cosworth 4x4 CAT, 2.8 i XR 4x4, 2.9 i XR 4x4		<b>G9-524</b>		H=52; d=12.1; D1=31.5; D2=40

<b>AK-735011</b>	<b>AK-735149</b>	<b>F8-3018</b>	<b>F8-3020</b>	<b>F8-3027</b>	<b>F8-5075</b>	<b>F8-5204</b>
Ref.Nr.:	Ref.Nr.: 6176933	Ref.Nr.: 6112404	Ref.Nr.: 85BB3K099AA	Ref.Nr.: 90170695	Ref.Nr.: 1619120	Ref.Nr.: 6094239
<b>F8-5507</b>	<b>F8-5880</b>	<b>G9-501</b>	<b>G9-501S</b>	<b>G9-522</b>	<b>G9-524</b>	<b>LM-10027S</b>
Ref.Nr.: 6119999	Ref.Nr.: 6150276	Ref.Nr.: 5021729	Ref.Nr.: 6122507	Ref.Nr.: 1619120	Ref.Nr.: 1632679	Ref.Nr.: 6128736
<b>LM-10044S</b>						
Ref.Nr.: 1619061						



**Article Description****Article Nr.****Fitting Position**

<b>SIERRA Hatchback (GBC, GBG)</b>			<b>01/1987 → 02/1993</b>		
Bellow, steering	1.6, 2.0, 2.3 D	with clamps;	<b>LM-10027S</b>		d1=11; d2=48; L [mm]=220
Bellow, steering	1.8	; ; ;  1.8 CFI, 1.8 HC; with clamps; ;	<b>LM-10027S</b>		d1=11; d2=48; L [mm]=220
Bellow, steering	1.8	; ; ;  1.8 HC; with clamps; ;	<b>LM-10027S</b>		d1=11; d2=48; L [mm]=220
Bellow, steering	1.8 TD	; ; ;  with clamps; ;	<b>LM-10027S</b>		d1=11; d2=48; L [mm]=220
Bellow, steering	2.0 i	; ; ;  2.0 HC EFI; with clamps; ;	<b>LM-10027S</b>		d1=11; d2=48; L [mm]=220
Bellow, steering	2.0 i CAT	; ; ;  2.0 LC EFI; with clamps; ;	<b>LM-10027S</b>		d1=11; d2=48; L [mm]=220
Bellow, steering	2.0 i DOHC	; ; ;  2.0 EFI; with clamps; ;	<b>LM-10027S</b>		d1=11; d2=48; L [mm]=220
Bellow, steering	2.0 i, 2.0 RS Cosworth	; ; ;  2.0 HC; with clamps; ;	<b>LM-10027S</b>		d1=11; d2=48; L [mm]=220
Bellow, steering	2.8 i, 2.8 i XR 4x4	; ; ;  2.8 EFI; with clamps; ;	<b>LM-10027S</b>		d1=11; d2=48; L [mm]=220
Bellow, steering	2.9 i, 2.9 i XR 4x4	; ; ;  2.9 EFI; with clamps; ;	<b>LM-10027S</b>		d1=11; d2=48; L [mm]=220
Bellow, steering	1.6, 1.6 i, 1.8, 1.8 TD, 2.0, 2.0 16V Cosworth 4x4, 2.0 16V Cosworth 4x4 CAT, 2.0 i, 2.0 i CAT, 2.0 RS Cosworth, 2.3 D, 2.8 i XR 4x4, 2.9 i	with clamps;	<b>LM-10044S</b>		d1=10; d2=36.5; L [mm]=200
<b>SIERRA Estate (BNG)</b>			<b>01/1987 → 02/1993</b>		
Dust Cover Kit, shock absorber	1.6, 1.6 i, 1.8, 1.8 TD, 2.0, 2.0 i, 2.0 i CAT, 2.3 D, 2.9		<b>AK-735011</b>		
Dust Cover Kit, shock absorber	1.6, 1.6 i, 1.8, 1.8 TD, 2.0, 2.0 4x4, 2.0 i, 2.0 i CAT, 2.0 i DOHC, 2.3 D, 2.8 4x4, 2.8 i, 2.8 i 4x4, 2.9, 2.9 4x4, 2.9 i		<b>AK-735149</b>		
Anti-Friction Bearing	1.6, 1.6 i, 1.8, 1.8 TD, 2.0, 2.0 4x4, 2.0 i, 2.0 i CAT, 2.3 D, 2.8 4x4, 2.9, 2.9 4x4, 2.9 i		<b>F8-3018</b>		H=11; d1=12; d2=20; D=42.2
Anti-Friction Bearing	1.6, 1.6 i, 1.8, 1.8 TD, 2.0, 2.0 4x4, 2.0 i, 2.0 i CAT, 2.3 D, 2.8 4x4, 2.8 i, 2.8 i 4x4, 2.9, 2.9 4x4, 2.9 i		<b>F8-3020</b>		d=12; d1=12; d2=20; D=54; W=10
Anti-Friction Bearing	1.6, 1.6 i, 1.8, 1.8 TD, 2.0, 2.0 4x4, 2.0 i, 2.0 i CAT, 2.3 D, 2.8 4x4, 2.9, 2.9 4x4, 2.9 i		<b>F8-3027</b>		H=27; d=12; D1=95; D2=130
Control Arm-/Trailing Arm Bush	1.6, 1.6 i, 1.8, 1.8 TD, 2.0, 2.0 i, 2.0 i CAT, 2.3 D, 2.8 4x4, 2.9		<b>F8-5075</b>		H=51; d=10; D=33
Mounting, axle beam	1.6, 1.6 i, 1.8, 1.8 TD, 2.0, 2.0 4x4, 2.0 i, 2.0 i CAT, 2.3 D, 2.8 4x4, 2.8 i, 2.8 i 4x4, 2.9, 2.9 4x4, 2.9 i		<b>F8-5204</b>		d=14
Top Strut Mounting	1.6, 1.6 i, 1.8, 1.8 TD, 2.0, 2.0 4x4, 2.0 i, 2.0 i CAT, 2.3 D, 2.8 4x4, 2.8 i, 2.8 i 4x4, 2.9, 2.9 4x4, 2.9 i		<b>F8-5507</b>		
Top Strut Mounting	1.6, 1.6 i, 1.8, 1.8 TD, 2.0, 2.0 4x4, 2.0 i, 2.0 i CAT, 2.0 i DOHC, 2.3 D, 2.8 4x4, 2.8 i, 2.8 i 4x4, 2.9, 2.9 4x4, 2.9 i		<b>F8-5880</b>		
Control Arm-/Trailing Arm Bush	1.6, 1.6 i, 1.8, 1.8 TD, 2.0, 2.0 4x4, 2.0 i, 2.0 i CAT, 2.3 D, 2.8 4x4, 2.8 i, 2.8 i 4x4, 2.9, 2.9 4x4, 2.9 i		<b>G9-501</b>		H=23; d=16; D1=49; D2=65

<b>AK-735011</b>	<b>AK-735149</b>	<b>F8-3018</b>	<b>F8-3020</b>	<b>F8-3027</b>	<b>F8-5075</b>	<b>F8-5204</b>
Ref.Nr.:	Ref.Nr.: 6176933	Ref.Nr.: 6112404	Ref.Nr.: 85BB3K099AA	Ref.Nr.: 90170695	Ref.Nr.: 1619120	Ref.Nr.: 6094239
<b>F8-5507</b>	<b>F8-5880</b>	<b>G9-501</b>	<b>G9-501S</b>	<b>LM-10027S</b>	<b>LM-10044S</b>	
Ref.Nr.: 6119999	Ref.Nr.: 6150276	Ref.Nr.: 5021729	Ref.Nr.: 6122507	Ref.Nr.: 6128736	Ref.Nr.: 1619061	

Article Description



Article Nr.

Fitting Position



<b>SIERRA Estate (BNG)</b>		<b>01/1987 → 02/1993</b>	
Control Arm-/Trailing Arm Bush	1.6, 1.6 i, 1.8, 1.8 TD, 2.0, 2.0 4x4, 2.0 i, 2.0 i CAT, 2.3 D, 2.8 4x4, 2.8 i, 2.8 i 4x4, 2.9, 2.9 4x4, 2.9 i		<b>G9-501S</b>
Control Arm-/Trailing Arm Bush	1.6, 1.6 i, 1.8, 1.8 TD, 2.0, 2.0 4x4, 2.0 i, 2.0 i CAT, 2.3 D, 2.8 4x4, 2.8 i, 2.8 i 4x4, 2.9, 2.9 4x4, 2.9 i		<b>G9-522</b>
Control Arm-/Trailing Arm Bush	2.0 4x4, 2.8 4x4, 2.8 i 4x4, 2.9 4x4		<b>G9-524</b>
Bellow, steering	1.6, 2.0, 2.3 D	with clamps;	<b>LM-10027S</b>
Bellow, steering	1.8	; ; ;  1.8 CFI, 1.8 HC; with clamps; ;	<b>LM-10027S</b>
Bellow, steering	1.8	; ; ;  1.8 HC; with clamps; ;	<b>LM-10027S</b>
Bellow, steering	1.8 TD	; ; ; ; with clamps; ;	<b>LM-10027S</b>
Bellow, steering	2.0 i	; ; ;  2.0 HC EFI; with clamps; ;	<b>LM-10027S</b>
Bellow, steering	2.0 i	; ; ;  2.0 HC; with clamps; ;	<b>LM-10027S</b>
Bellow, steering	2.0 i CAT	; ; ;  2.0 LC EFI; with clamps; ;	<b>LM-10027S</b>
Bellow, steering	2.0 i DOHC	; ; ;  2.0 EFI; with clamps; ;	<b>LM-10027S</b>
Bellow, steering	2.8 4x4, 2.8 i, 2.8 i 4x4	; ; ;  2.8 EFI; with clamps; ;	<b>LM-10027S</b>
Bellow, steering	2.9, 2.9 4x4	; ; ;  2.9 EFI; with clamps; ;	<b>LM-10027S</b>
Bellow, steering	1.6, 1.6 i, 1.8, 1.8 TD, 2.0, 2.0 i, 2.0 i CAT, 2.3 D, 2.8 4x4, 2.9	with clamps;	<b>LM-10044S</b>
<b>S-MAX (WA6)</b>		<b>05/2006 →</b>	
Alternator Freewheel Clutch	2.0 TDCi, 2.2 TDCi		<b>F5-1046</b>
Alternator Freewheel Clutch	1.8 TDCi		<b>F5-1057</b>
Alternator Freewheel Clutch	2.0, 2.0 Flexifuel	Manufacturer Restriction: Denso	<b>F5-1059</b>
Alternator Freewheel Clutch	2.0, 2.0 Flexifuel		<b>F5-1075</b>
Alternator Freewheel Clutch	2.0 EcoBoost		<b>F5-1134</b>
Belt Pulley, crankshaft	1.8 TDCi	Number of Ribs: 6	<b>F8-6399</b>
Top Strut Mounting	1.6 EcoBoost, 1.6 TDCi, 1.8 TDCi, 2.0, 2.0 EcoBoost, 2.0 Flexifuel, 2.0 TDCi, 2.2 TDCi, 2.3, 2.5 ST		<b>F8-7606</b>
Anti-Friction Bearing	1.6 EcoBoost, 1.6 TDCi, 1.8 TDCi, 2.0, 2.0 EcoBoost, 2.0 Flexifuel, 2.0 TDCi, 2.2 TDCi, 2.3, 2.5 ST		<b>F8-7607</b>
Top Strut Mounting	1.6 EcoBoost, 1.6 TDCi, 1.8 TDCi, 2.0, 2.0 EcoBoost, 2.0 Flexifuel, 2.0 TDCi, 2.2 TDCi, 2.3, 2.5 ST		<b>F8-7608</b>
Control Arm-/Trailing Arm Bush	1.6 EcoBoost, 1.6 TDCi, 1.8 TDCi, 2.0, 2.0 EcoBoost, 2.0 Flexifuel, 2.0 TDCi, 2.2 TDCi, 2.3, 2.5 ST		<b>F8-7877</b>
Control Arm-/Trailing Arm Bush	1.6 EcoBoost, 1.6 TDCi, 1.8 TDCi, 2.0, 2.0 EcoBoost, 2.0 Flexifuel, 2.0 TDCi, 2.2 TDCi, 2.3, 2.5 ST		<b>F8-7878</b>

<b>F5-1046</b>	<b>F5-1057</b>	<b>F5-1059</b>	<b>F5-1075</b>	<b>F5-1134</b>	<b>F8-6399</b>	<b>F8-7606</b>
Ref.Nr.: 30667687	Ref.Nr.: 5M5Q-10344-AA	Ref.Nr.: 3M5T-10300-VC	Ref.Nr.: 30667610	Ref.Nr.: 31285489	Ref.Nr.: 1151 392	Ref.Nr.: 1734710
<b>F8-7607</b>	<b>F8-7608</b>	<b>F8-7877</b>	<b>F8-7878</b>	<b>F8-8074</b>	<b>G9-501S</b>	<b>G9-522</b>
Ref.Nr.: 1510474	Ref.Nr.: 6G91-3K099-NB	Ref.Nr.: 1865033	Ref.Nr.: 31 277 755	Ref.Nr.: 7G9J-3A262-AB	Ref.Nr.: 6122507	Ref.Nr.: 1619120
<b>G9-524</b>	<b>LM-10027S</b>	<b>LM-10044S</b>				
Ref.Nr.: 1632679	Ref.Nr.: 6128736	Ref.Nr.: 1619061				

**Article Description****Article Nr.****Fitting Position**

<b>S-MAX (WA6)</b>			<b>05/2006 →</b>		
Control Arm-/Trailing Arm Bush	All Models		<b>F8-8074</b>		
Control Arm-/Trailing Arm Bush	All Models		<b>F8-8075</b>		
<b>STREET KA (RL2)</b>			<b>05/2003 → 07/2005</b>		
Dust Cover Kit, shock absorber	All Models		<b>AK-735405</b>		
Top Strut Mounting	All Models		<b>F8-5409</b>		d=22; D1=99; D2=106
Mounting, axle beam	All Models		<b>F8-6074</b>		H1=70; H2=55; D=63.2
Top Strut Mounting	All Models		<b>F8-6312</b>		
<b>TAUNUS 12M (11G)</b>			<b>08/1966 → 06/1971</b>		
Bellow, steering	1.3	with clamps	<b>LM-10062S</b>		d1=10; d2=46; L [mm]=145
<b>TAUNUS 12M Coupe (13G)</b>			<b>08/1966 → 06/1971</b>		
Bellow, steering	All Models	with clamps	<b>LM-10062S</b>		d1=10; d2=46; L [mm]=145
<b>TAUNUS 12M Turnier (15G)</b>			<b>09/1966 → 06/1971</b>		
Bellow, steering	All Models	with clamps	<b>LM-10062S</b>		d1=10; d2=46; L [mm]=145
<b>TOURNEO CONNECT</b>			<b>06/2002 → 12/2013</b>		
Alternator Freewheel Clutch	1.8 Di, 1.8 TDCi, 1.8 Turbo Di		<b>F5-1057</b>		
Top Strut Mounting	1.8 16V, 1.8 Di, 1.8 TDCi, 1.8 Turbo Di		<b>F8-6066</b>		Outer Thread [mm]=M8 x 1,5
Top Strut Mounting	1.8 16V, 1.8 Di, 1.8 TDCi, 1.8 Turbo Di		<b>F8-6318</b>		
Belt Pulley, crankshaft	1.8 Turbo Di	Number of Ribs: 6	<b>F8-6399</b>		
<b>TOURNEO CUSTOM Bus</b>			<b>04/2012 →</b>		
Alternator Freewheel Clutch	2.2 TDCi		<b>F5-1125</b>		
Top Strut Mounting	2.2 TDCi		<b>F8-7456</b>		
Anti-Friction Bearing	2.2 TDCi		<b>F8-7609</b>		
<b>TRANSIT Bus (V_ )</b>			<b>10/1983 → 10/1986</b>		
Control Arm-/Trailing Arm Bush	2.5 D		<b>F8-5252</b>		H=52; d=16; D=52, 60
<b>TRANSIT Platform/Chassis (V_ )</b>			<b>11/1977 → 10/1986</b>		
Control Arm-/Trailing Arm Bush	1.6	11/1985 →	<b>F8-5252</b>		H=52; d=16; D=52, 60
<b>TRANSIT Bus (T_ )</b>			<b>10/1985 → 09/1992</b>		
Control Arm-/Trailing Arm Bush	1.6, 2.0, 2.5 D		<b>F8-5135</b>		d=16; D=41; W=91
Control Arm-/Trailing Arm Bush	1.6, 2.0, 2.5 D		<b>F8-5252</b>		H=52; d=16; D=52, 60
Stabiliser Mounting	1.6, 2.0, 2.5 D		<b>F8-6048</b>		



Article Description

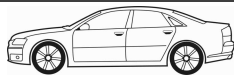

Article Nr.

Fitting Position



<b>TRANSIT Bus (T_ )</b>				<b>10/1985 → 09/1992</b>	
Stabiliser Mounting	2.0 L, 2.5 D	: 80-120	<b>F8-6048</b>	⊕ ⊕	
Bellow, steering	All Models	Manufacturer Restriction: 80-120; with clamps;	<b>LM-10019S</b>		d1=15; d2=49; L [mm]=185
<b>TRANSIT Van (T_ )</b>				<b>09/1985 → 09/1992</b>	
Control Arm-/Trailing Arm Bush	1.6, 2.0, 2.5 D		<b>F8-5135</b>	⊕ ⊕	d=16; D=41; W=91
Control Arm-/Trailing Arm Bush	1.6, 2.0, 2.5 D		<b>F8-5252</b>	⊕ ⊕	H=52; d=16; D=52, 60
Stabiliser Mounting	1.6, 2.0, 2.5 D		<b>F8-6048</b>	⊕ ⊕	
Bellow, steering	1.6, 2.0, 2.5 D	Manufacturer Restriction: 80-120; with clamps;	<b>LM-10019S</b>		d1=15; d2=49; L [mm]=185
<b>TRANSIT Platform/Chassis (T_ )</b>				<b>11/1985 → 09/1992</b>	
Control Arm-/Trailing Arm Bush	All Models		<b>F8-5135</b>	⊕ ⊕	d=16; D=41; W=91
Control Arm-/Trailing Arm Bush	All Models		<b>F8-5252</b>	⊕ ⊕	H=52; d=16; D=52, 60
Stabiliser Mounting	All Models		<b>F8-6048</b>	⊕ ⊕	
Bellow, steering	All Models	Manufacturer Restriction: 80-120; with clamps;	<b>LM-10019S</b>		d1=15; d2=49; L [mm]=185
<b>TRANSIT Bus (E_ )</b>				<b>01/1991 → 09/1994</b>	
Control Arm-/Trailing Arm Bush	All Models		<b>F8-5135</b>	⊕ ⊕	d=16; D=41; W=91
Control Arm-/Trailing Arm Bush	All Models		<b>F8-5252</b>	⊕ ⊕	H=52; d=16; D=52, 60
Top Strut Mounting	All Models		<b>F8-5505</b>	⊕ ⊕	
Repair Kit, suspension strut	2.0, 2.0 i, 2.5 DI, 2.5 TD	01/1992 →	<b>F8-6313</b>	⊕ ⊕	
Repair Kit, suspension strut	2.5 TD, 2.9 i		<b>F8-6313</b>	⊕ ⊕	
Engine Mounting	2.5 DI	02/1994 →	<b>F8-6954</b>	⊕	
Mounting, propshaft	2.0 i, 2.5 DI, 2.5 TD, 2.9 i		<b>F8-8224</b>		
Bellow, steering	All Models	Manufacturer Restriction: 80-120; with clamps;	<b>LM-10019S</b>		d1=15; d2=49; L [mm]=185
<b>TRANSIT Van (E_ )</b>				<b>05/1991 → 06/1994</b>	
Control Arm-/Trailing Arm Bush	All Models		<b>F8-5135</b>	⊕ ⊕	d=16; D=41; W=91
Control Arm-/Trailing Arm Bush	All Models		<b>F8-5252</b>	⊕ ⊕	H=52; d=16; D=52, 60
Top Strut Mounting	All Models		<b>F8-5505</b>	⊕ ⊕	
Repair Kit, suspension strut	2.0, 2.0 i, 2.5 DI, 2.5 TD	01/1992 →	<b>F8-6313</b>	⊕ ⊕	
Repair Kit, suspension strut	2.5 DI		<b>F8-6313</b>	⊕ ⊕	
Engine Mounting	2.5 DI	02/1994 →	<b>F8-6954</b>	⊕	

<b>F8-5135</b>	<b>F8-5252</b>	<b>F8-5505</b>	<b>F8-6048</b>	<b>F8-6313</b>	<b>F8-6954</b>	<b>F8-8224</b>
Ref.Nr.: 6517356	Ref.Nr.: 6608818	Ref.Nr.: 6675788	Ref.Nr.: 6150977	Ref.Nr.: 6675788	Ref.Nr.: 6908393	Ref.Nr.: 4104708
<b>LM-10019S</b>						
Ref.Nr.: 6156467						

**Article Description****Article Nr.****Fitting Position**

<b>TRANSIT Van (E_ _)</b>				<b>05/1991 → 06/1994</b>	
Mounting, propshaft	All Models		<b>F8-8224</b>		
Bellow, steering	All Models	Manufacturer Restriction: 80-120; with clamps;	<b>LM-10019S</b>		d1=15; d2=49; L [mm]=185
<b>TRANSIT Platform/Chassis (E_ _)</b>				<b>09/1991 → 08/1994</b>	
Control Arm-/Trailing Arm Bush	2.0 , 2.5 DI , 2.5 TD		<b>F8-5135</b>		d=16; D=41; W=91
Control Arm-/Trailing Arm Bush	2.0 , 2.5 DI , 2.5 TD		<b>F8-5252</b>		H=52; d=16; D=52, 60
Top Strut Mounting	2.0 , 2.5 DI , 2.5 TD		<b>F8-5505</b>		
Repair Kit, suspension strut	2.0 , 2.5 DI , 2.5 TD	01/1992 →	<b>F8-6313</b>		
Repair Kit, suspension strut	2.5 TD		<b>F8-6313</b>		
Engine Mounting	2.5 DI	02/1994 →	<b>F8-6954</b>		
Mounting, propshaft	2.0 , 2.5 DI , 2.5 TD		<b>F8-8224</b>		
Bellow, steering	2.0 , 2.5 DI , 2.5 TD	Manufacturer Restriction: 80-120; with clamps;	<b>LM-10019S</b>		d1=15; d2=49; L [mm]=185
<b>TRANSIT Bus (E_ _)</b>				<b>06/1994 → 06/2000</b>	
Control Arm-/Trailing Arm Bush	All Models		<b>F8-5135</b>		d=16; D=41; W=91
Control Arm-/Trailing Arm Bush	2.0 , 2.0 CNG, 2.5 DI , 2.5 TD		<b>F8-5252</b>		H=52; d=16; D=52, 60
Top Strut Mounting	2.0 , 2.0 CNG, 2.5 DI , 2.5 TD		<b>F8-5505</b>		
Top Strut Mounting	2.5 DI	01/2000 →;	<b>F8-6164</b>		
Repair Kit, suspension strut	All Models		<b>F8-6313</b>		
Engine Mounting	2.5 DI		<b>F8-6970</b>		
Engine Mounting	2.5 DI		<b>F8-6971</b>		
Mounting, propshaft	All Models		<b>F8-8224</b>		
Bellow, steering	All Models	Manufacturer Restriction: 80-120; with clamps;	<b>LM-10019S</b>		d1=15; d2=49; L [mm]=185
<b>TRANSIT Van (E_ _)</b>				<b>06/1994 → 03/2000</b>	
Control Arm-/Trailing Arm Bush	All Models		<b>F8-5135</b>		d=16; D=41; W=91
Control Arm-/Trailing Arm Bush	2.0 , 2.5 DI , 2.5 TD , 2.5 TDI		<b>F8-5252</b>		H=52; d=16; D=52, 60
Top Strut Mounting	2.0 , 2.5 DI , 2.5 TD , 2.5 TDI		<b>F8-5505</b>		
Repair Kit, stabilizer coupling rod	2.5 DI	Coupling Rod	<b>F8-6118</b>		L=72
Control Arm-/Trailing Arm Bush	2.5 DI		<b>F8-6162</b>		H1=40; H2=72; d=16.5; D=66
Control Arm-/Trailing Arm Bush	2.5 DI		<b>F8-6163</b>		H=67; d=14; D1=37; D2=44



Article Description



Article Nr.

Fitting Position



<b>TRANSIT Van (E_ _)</b>			<b>06/1994 → 03/2000</b>		
Top Strut Mounting	2.5 DI	01/2000 →;	<b>F8-6164</b>		
Repair Kit, suspension strut	All Models		<b>F8-6313</b>		
Engine Mounting	2.5 DI		<b>F8-6970</b>		
Engine Mounting	2.5 DI		<b>F8-6971</b>		
Mounting, propshaft	All Models		<b>F8-8224</b>		
Bellow, steering	All Models	Manufacturer Restriction: 80-120; with clamps;	<b>LM-10019S</b>		d1=15; d2=49; L [mm]=185
<b>TRANSIT Platform/Chassis (E_ _)</b>			<b>08/1994 → 07/2000</b>		
Control Arm-/Trailing Arm Bush	All Models		<b>F8-5135</b>		d=16; D=41; W=91
Control Arm-/Trailing Arm Bush	2.0, 2.5 DI, 2.5 TD		<b>F8-5252</b>		H=52; d=16; D=52, 60
Top Strut Mounting	2.0, 2.5 DI, 2.5 TD		<b>F8-5505</b>		
Repair Kit, stabilizer coupling rod	2.5 DI	Coupling Rod	<b>F8-6118</b>		L=72
Control Arm-/Trailing Arm Bush	2.5 DI		<b>F8-6162</b>		H1=40; H2=72; d=16.5; D=66
Control Arm-/Trailing Arm Bush	2.5 DI		<b>F8-6163</b>		H=67; d=14; D1=37; D2=44
Top Strut Mounting	2.5 DI	01/2000 →;	<b>F8-6164</b>		
Repair Kit, suspension strut	All Models		<b>F8-6313</b>		
Engine Mounting	2.5 DI		<b>F8-6970</b>		
Engine Mounting	2.5 DI		<b>F8-6971</b>		
Mounting, propshaft	All Models		<b>F8-8224</b>		
Bellow, steering	All Models	Manufacturer Restriction: 80-120; with clamps;	<b>LM-10019S</b>		d1=15; d2=49; L [mm]=185
<b>TRANSIT Bus (FD_ _ , FB_ _ , FS_ _ , FZ_ _ , FC_ _)</b>			<b>01/2000 → 05/2006</b>		
Dust Cover Kit, shock absorber	2.0 DI, 2.0 TDCi, 2.3 16V [RWD], 2.4 DI, 2.4 DI [RWD], 2.4 TDCi, 2.4 TDE		<b>AK-735076</b>		
Alternator Freewheel Clutch	2.4 DI, 2.4 DI [RWD], 2.4 TD, 2.4 TDCi, 2.4 TDdi, 2.4 TDE		<b>F5-1021</b>		
Alternator Freewheel Clutch	2.4 DI, 2.4 DI [RWD], 2.4 TD, 2.4 TDCi, 2.4 TDdi, 2.4 TDE		<b>F5-1023</b>		
Alternator Freewheel Clutch	2.3, 2.3 16V [RWD]		<b>F5-1077</b>		
Repair Kit, stabilizer coupling rod	2.0 DI, 2.0 TDCi, 2.3 16V [RWD], 2.4 DI, 2.4 DI [RWD], 2.4 TDCi, 2.4 TDdi, 2.4 TDE	Coupling Rod	<b>F8-6118</b>		L=72
Control Arm-/Trailing Arm Bush	2.0 DI, 2.0 TDCi, 2.3 16V [RWD], 2.4 DI, 2.4 DI [RWD], 2.4 TDCi, 2.4 TDdi, 2.4 TDE		<b>F8-6162</b>		H1=40; H2=72; d=16.5; D=66
Control Arm-/Trailing Arm Bush	2.0 DI, 2.0 TDCi, 2.3 16V [RWD], 2.4 DI, 2.4 DI [RWD], 2.4 TDCi, 2.4 TDdi, 2.4 TDE		<b>F8-6163</b>		H=67; d=14; D1=37; D2=44

<b>AK-735076</b>	<b>F5-1021</b>	<b>F5-1023</b>	<b>F5-1077</b>	<b>F8-5135</b>	<b>F8-5252</b>	<b>F8-5505</b>
Ref.Nr.:	Ref.Nr.:	Ref.Nr.: 2C1U-10A352-A	Ref.Nr.:	Ref.Nr.: 6517356	Ref.Nr.: 6608818	Ref.Nr.: 6675788
<b>F8-6118</b>	<b>F8-6162</b>	<b>F8-6163</b>	<b>F8-6164</b>	<b>F8-6313</b>	<b>F8-6970</b>	<b>F8-6971</b>
Ref.Nr.: 3736028	Ref.Nr.: YC153A262AD	Ref.Nr.: 4041450	Ref.Nr.: 4094373	Ref.Nr.: 6675788	Ref.Nr.: 7128520	Ref.Nr.: 95VB6B032BD
<b>F8-8224</b>	<b>LM-10019S</b>					
Ref.Nr.: 4104708	Ref.Nr.: 6156467					

**Article Description****Article Nr.****Fitting Position**

<b>TRANSIT Bus (FD_ , FB_ , FS_ , FZ_ , FC_ )</b>			<b>01/2000 → 05/2006</b>		
Top Strut Mounting	2.0 DI , 2.0 TDCi , 2.3 16V [RWD] , 2.4 DI , 2.4 DI [RWD] , 2.4 TDCi , 2.4 TDi , 2.4 TDE		<b>F8-6164</b>		
Anti-Friction Bearing	2.0 DI , 2.0 TDCi , 2.3 16V [RWD] , 2.4 DI , 2.4 DI [RWD] , 2.4 TDCi , 2.4 TDE		<b>F8-6262</b>		
Top Strut Mounting	2.0 DI , 2.0 TDCi , 2.3 16V [RWD] , 2.4 DI , 2.4 DI [RWD] , 2.4 TDCi , 2.4 TDi , 2.4 TDE		<b>F8-6316</b>		
Rubber Buffer, suspension	2.0 DI , 2.0 TDCi , 2.3 16V [RWD] , 2.4 DI , 2.4 DI [RWD] , 2.4 TDCi , 2.4 TDi , 2.4 TDE		<b>F8-7582</b>		H=92
Belt Pulley, crankshaft	2.0 DI , 2.0 TDCi	Number of Ribs: 5; Parameter: 6PK	<b>F8-7650</b>		D=167; Thick. [mm]=37
<b>TRANSIT Platform/Chassis (FM_ , FN_ )</b>			<b>01/2000 → 05/2006</b>		
Dust Cover Kit, shock absorber	2.0 DI , 2.0 TDCi , 2.3 16V , 2.4 DI , 2.4 TDCi , 2.4 TDE		<b>AK-735076</b>		
Alternator Freewheel Clutch	2.4 DI , 2.4 TDCi , 2.4 TDi , 2.4 TDE		<b>F5-1021</b>		
Alternator Freewheel Clutch	2.4 DI , 2.4 TDCi , 2.4 TDi , 2.4 TDE		<b>F5-1023</b>		
Alternator Freewheel Clutch	2.3 16V		<b>F5-1077</b>		
Repair Kit, stabilizer coupling rod	2.0 DI , 2.0 TDCi , 2.3 16V , 2.4 DI , 2.4 TDCi , 2.4 TDi , 2.4 TDE	Coupling Rod	<b>F8-6118</b>		L=72
Control Arm-/Trailing Arm Bush	2.0 DI , 2.0 TDCi , 2.3 16V , 2.4 DI , 2.4 TDCi , 2.4 TDi , 2.4 TDE		<b>F8-6162</b>		H1=40; H2=72; d=16.5; D=66
Control Arm-/Trailing Arm Bush	2.0 DI , 2.0 TDCi , 2.3 16V , 2.4 DI , 2.4 TDCi , 2.4 TDi , 2.4 TDE		<b>F8-6163</b>		H=67; d=14; D1=37; D2=44
Top Strut Mounting	2.0 DI , 2.0 TDCi , 2.3 16V , 2.4 DI , 2.4 TDCi , 2.4 TDi , 2.4 TDE		<b>F8-6164</b>		
Anti-Friction Bearing	2.0 DI , 2.0 TDCi , 2.3 16V , 2.4 DI , 2.4 TDCi , 2.4 TDE		<b>F8-6262</b>		
Top Strut Mounting	2.0 DI , 2.0 TDCi , 2.3 16V , 2.4 DI , 2.4 TDCi , 2.4 TDi , 2.4 TDE		<b>F8-6316</b>		
Rubber Buffer, suspension	2.0 DI , 2.0 TDCi , 2.3 16V , 2.4 DI , 2.4 TDCi , 2.4 TDi , 2.4 TDE		<b>F8-7582</b>		H=92
Belt Pulley, crankshaft	2.0 DI , 2.0 TDCi	Number of Ribs: 5; Parameter: 6PK	<b>F8-7650</b>		D=167; Thick. [mm]=37
<b>TRANSIT Van (FA_ )</b>			<b>01/2000 → 05/2006</b>		
Dust Cover Kit, shock absorber	2.0 DI , 2.0 TDCi , 2.3 16V [RWD] , 2.4 DI , 2.4 DI [RWD] , 2.4 TDCi , 2.4 TDE		<b>AK-735076</b>		
Alternator Freewheel Clutch	2.4 DI , 2.4 DI [RWD] , 2.4 TD , 2.4 TDCi , 2.4 TDi , 2.4 TDE		<b>F5-1021</b>		
Alternator Freewheel Clutch	2.4 DI , 2.4 DI [RWD] , 2.4 TD , 2.4 TDCi , 2.4 TDi , 2.4 TDE		<b>F5-1023</b>		
Alternator Freewheel Clutch	2.3 , 2.3 16V [RWD]		<b>F5-1077</b>		
Repair Kit, stabilizer coupling rod	2.0 DI , 2.0 TDCi , 2.3 , 2.3 16V [RWD] , 2.4 DI , 2.4 DI [RWD] , 2.4 TDCi , 2.4 TDi , 2.4 TDE	Coupling Rod	<b>F8-6118</b>		L=72
Control Arm-/Trailing Arm Bush	2.0 DI , 2.0 TDCi , 2.3 , 2.3 16V [RWD] , 2.4 DI , 2.4 DI [RWD] , 2.4 TDCi , 2.4 TDi , 2.4 TDE		<b>F8-6162</b>		H1=40; H2=72; d=16.5; D=66
Control Arm-/Trailing Arm Bush	2.0 DI , 2.0 TDCi , 2.3 , 2.3 16V [RWD] , 2.4 DI , 2.4 DI [RWD] , 2.4 TDCi , 2.4 TDi , 2.4 TDE		<b>F8-6163</b>		H=67; d=14; D1=37; D2=44

<b>AK-735076</b>	<b>F5-1021</b>	<b>F5-1023</b>	<b>F5-1077</b>	<b>F8-6118</b>	<b>F8-6162</b>	<b>F8-6163</b>
Ref.Nr.:	Ref.Nr.:	Ref.Nr.: 2C1U-10A352-A	Ref.Nr.:	Ref.Nr.: 3736028	Ref.Nr.: YC153A262AD	Ref.Nr.: 4041450
<b>F8-6164</b>	<b>F8-6262</b>	<b>F8-6316</b>	<b>F8-7582</b>	<b>F8-7650</b>		
Ref.Nr.: 4094373	Ref.Nr.: 97BG-3K099-AA	Ref.Nr.: 4094280	Ref.Nr.: 4041449	Ref.Nr.: 1S7Q6B319AB		

Article Description

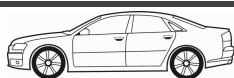

Article Nr.

Fitting Position



<b>TRANSIT Van (FA_ _)</b>		<b>01/2000 → 05/2006</b>	
Top Strut Mounting	2.0 DI , 2.0 TDCi, 2.3, 2.3 16V [RWD] , 2.4 DI , 2.4 DI [RWD] , 2.4 TDCi, 2.4 TDdi, 2.4 TDE		<b>F8-6164</b>
Anti-Friction Bearing	2.0 DI , 2.0 TDCi, 2.3 16V [RWD] , 2.4 DI , 2.4 DI [RWD] , 2.4 TDCi, 2.4 TDE		<b>F8-6262</b>
Top Strut Mounting	2.0 DI , 2.0 TDCi, 2.3, 2.3 16V [RWD] , 2.4 DI , 2.4 DI [RWD] , 2.4 TDCi, 2.4 TDdi, 2.4 TDE		<b>F8-6316</b>
Rubber Buffer, suspension	2.0 DI , 2.0 TDCi, 2.3, 2.3 16V [RWD] , 2.4 DI , 2.4 DI [RWD] , 2.4 TDCi, 2.4 TDdi, 2.4 TDE		<b>F8-7582</b>
Belt Pulley, crankshaft	2.0 DI , 2.0 TDCi	Number of Ribs: 5; Parameter: 6PK	<b>F8-7650</b>
<b>TRANSIT Bus</b>		<b>04/2006 → 08/2014</b>	
Alternator Freewheel Clutch	All Models		<b>F5-1101</b>
Alternator Freewheel Clutch	All Models		<b>F5-1125</b>
Control Arm-/Trailing Arm Bush	2.2 TDCi, 2.4 TDCi		<b>F8-6162</b>
Control Arm-/Trailing Arm Bush	2.2 TDCi, 2.4 TDCi		<b>F8-6163</b>
Belt Pulley, crankshaft	2.2 TDCi	Number of Ribs: 3, 5; Parameter: 6 PK + 4 PK	<b>F8-6571</b>
Top Strut Mounting	All Models		<b>F8-7456</b>
Anti-Friction Bearing	All Models		<b>F8-7609</b>
Belt Pulley, crankshaft	2.4 TDCi	H9FB; Number of Ribs: 6; Parameter: 7PK	<b>F8-7651</b>
Belt Pulley, crankshaft	2.4 TDCi	JXFA; Number of Ribs: 6; Parameter: 7PK	<b>F8-7651</b>
Belt Pulley, crankshaft	2.4 TDCi	PHFA; Number of Ribs: 6; Parameter: 7PK	<b>F8-7651</b>
Rubber Buffer, suspension	2.2 TDCi, 2.4 TDCi, 2.4 TDCi 4x4, 3.2 TDCi		<b>F8-7712</b>
<b>TRANSIT Box</b>		<b>04/2006 → 08/2014</b>	
Alternator Freewheel Clutch	2.2 TDCi, 2.2 TDCi [RWD], 2.2 TDCi 4x4, 2.4 TDCi, 2.4 TDCi 4x4, 3.2 TDCi		<b>F5-1101</b>
Alternator Freewheel Clutch	2.2 TDCi, 2.2 TDCi [RWD], 2.2 TDCi 4x4, 2.4 TDCi, 2.4 TDCi 4x4, 3.2 TDCi		<b>F5-1125</b>
Control Arm-/Trailing Arm Bush	2.2 TDCi, 2.3 16V, 2.4 TDCi		<b>F8-6162</b>
Control Arm-/Trailing Arm Bush	2.2 TDCi, 2.3 16V, 2.4 TDCi		<b>F8-6163</b>
Belt Pulley, crankshaft	2.2 TDCi	Number of Ribs: 3, 5; Parameter: 6 PK + 4 PK	<b>F8-6571</b>
Top Strut Mounting	2.2 TDCi, 2.2 TDCi [RWD], 2.2 TDCi 4x4, 2.3 16V, 2.4 TDCi, 2.4 TDCi 4x4, 3.2 TDCi		<b>F8-7456</b>

<b>F5-1101</b>	<b>F5-1125</b>	<b>F8-6162</b>	<b>F8-6163</b>	<b>F8-6164</b>	<b>F8-6262</b>	<b>F8-6316</b>
Ref.Nr.: 27415-0L020	Ref.Nr.: 77364082	Ref.Nr.: YC153A262AD	Ref.Nr.: 4041450	Ref.Nr.: 4094373	Ref.Nr.: 97BG-3K099-AA	Ref.Nr.: 4094280
<b>F8-6571</b>	<b>F8-7456</b>	<b>F8-7582</b>	<b>F8-7609</b>	<b>F8-7650</b>	<b>F8-7651</b>	<b>F8-7712</b>
Ref.Nr.: 0515.T1	Ref.Nr.: 1377973	Ref.Nr.: 4041449	Ref.Nr.: 1808435	Ref.Nr.: 1S7Q6B319AB	Ref.Nr.: BK3Q-6B319-C	Ref.Nr.: 1388271



**Article Description****Article Nr.****Fitting Position**

<b>TRANSIT Box</b>			<b>04/2006 → 08/2014</b>	
Anti-Friction Bearing	2.2 TDCi, 2.2 TDCi [RWD], 2.2 TDCi 4x4, 2.3 16V, 2.4 TDCi, 2.4 TDCi 4x4, 3.2 TDCi		<b>F8-7609</b>	
Belt Pulley, crankshaft	2.4 TDCi	H9FB; Number of Ribs: 6; Parameter: 7PK	<b>F8-7651</b>	H=53; d1=50.03; d2=59; Mounting points diam.[mm]=13.1; D=167.3; D1=160; D2=133.5
Belt Pulley, crankshaft	2.4 TDCi	JXFA; Number of Ribs: 6; Parameter: 7PK	<b>F8-7651</b>	H=53; d1=50.03; d2=59; Mounting points diam.[mm]=13.1; D=167.3; D1=160; D2=133.5
Belt Pulley, crankshaft	2.4 TDCi	PHFA; Number of Ribs: 6; Parameter: 7PK	<b>F8-7651</b>	H=53; d1=50.03; d2=59; Mounting points diam.[mm]=13.1; D=167.3; D1=160; D2=133.5
Rubber Buffer, suspension	2.2 TDCi, 2.3 16V, 2.4 TDCi, 2.4 TDCi 4x4, 3.2 TDCi		<b>F8-7712</b>	
<b>TRANSIT Platform/Chassis</b>			<b>04/2006 → 08/2014</b>	
Alternator Freewheel Clutch	2.2 TDCi, 2.2 TDCi [RWD], 2.2 TDCi 4x4, 2.4 TDCi, 2.4 TDCi 4x4, 3.2 TDCi		<b>F5-1101</b>	
Alternator Freewheel Clutch	2.2 TDCi, 2.2 TDCi [RWD], 2.2 TDCi 4x4, 2.4 TDCi, 2.4 TDCi 4x4, 3.2 TDCi		<b>F5-1125</b>	
Control Arm-/Trailing Arm Bush	2.2 TDCi, 2.3 16V, 2.4 TDCi		<b>F8-6162</b>	H1=40; H2=72; d=16.5; D=66
Control Arm-/Trailing Arm Bush	2.2 TDCi, 2.3 16V, 2.4 TDCi		<b>F8-6163</b>	H=67; d=14; D1=37; D2=44
Belt Pulley, crankshaft	2.2 TDCi	Number of Ribs: 3, 5; Parameter: 6 PK + 4 PK	<b>F8-6571</b>	Bore Ø [mm]=13; H=50; D=167
Top Strut Mounting	2.2 TDCi, 2.2 TDCi [RWD], 2.2 TDCi 4x4, 2.3 16V, 2.4 TDCi, 2.4 TDCi 4x4, 3.2 TDCi		<b>F8-7456</b>	
Anti-Friction Bearing	2.2 TDCi, 2.2 TDCi [RWD], 2.2 TDCi 4x4, 2.3 16V, 2.4 TDCi, 2.4 TDCi 4x4, 3.2 TDCi		<b>F8-7609</b>	
Belt Pulley, crankshaft	2.4 TDCi	H9FB; Number of Ribs: 6; Parameter: 7PK	<b>F8-7651</b>	H=53; d1=50.03; d2=59; Mounting points diam.[mm]=13.1; D=167.3; D1=160; D2=133.5
Belt Pulley, crankshaft	2.4 TDCi	JXFA; Number of Ribs: 6; Parameter: 7PK	<b>F8-7651</b>	H=53; d1=50.03; d2=59; Mounting points diam.[mm]=13.1; D=167.3; D1=160; D2=133.5
Belt Pulley, crankshaft	2.4 TDCi	PHFA; Number of Ribs: 6; Parameter: 7PK	<b>F8-7651</b>	H=53; d1=50.03; d2=59; Mounting points diam.[mm]=13.1; D=167.3; D1=160; D2=133.5
Rubber Buffer, suspension	2.2 TDCi, 2.3 16V, 2.4 TDCi, 2.4 TDCi 4x4, 3.2 TDCi		<b>F8-7712</b>	
<b>TRANSIT CONNECT (P65_, P70_, P80_)</b>			<b>06/2002 → 12/2013</b>	
Alternator Freewheel Clutch	1.8 Di, 1.8 TDCi		<b>F5-1057</b>	
Top Strut Mounting	1.8 16V, 1.8 Di, 1.8 TDCi		<b>F8-6066</b>	Outer Thread [mm]=M8 x 1,5
Top Strut Mounting	1.8 16V, 1.8 Di, 1.8 TDCi		<b>F8-6318</b>	
Belt Pulley, crankshaft	1.8 Di, 1.8 TDCi	Number of Ribs: 6	<b>F8-6399</b>	
Engine Mounting	1.8 16V, 1.8 Di, 1.8 TDCi		<b>F8-6754</b>	

<b>F5-1057</b>	<b>F5-1101</b>	<b>F5-1125</b>	<b>F8-6066</b>	<b>F8-6162</b>	<b>F8-6163</b>	<b>F8-6318</b>
Ref.Nr.: 5M5Q-10344-AA	Ref.Nr.: 27415-0L020	Ref.Nr.: 77364082	Ref.Nr.: 1061722	Ref.Nr.: YC153A262AD	Ref.Nr.: 4041450	Ref.Nr.: 1115132
<b>F8-6399</b>	<b>F8-6571</b>	<b>F8-6754</b>	<b>F8-7456</b>	<b>F8-7609</b>	<b>F8-7649</b>	<b>F8-7651</b>
Ref.Nr.: 1151 392	Ref.Nr.: 0515.T1	Ref.Nr.: 98AB-6P082-MB	Ref.Nr.: 1377973	Ref.Nr.: 1808435	Ref.Nr.: 1131911	Ref.Nr.: BK3Q-6B319-C
<b>F8-7712</b>						
Ref.Nr.: 1388271						

Article Description

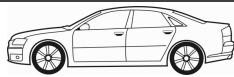

Article Nr.

Fitting Position



Article Description			Article Nr.	Fitting Position	
<b>TRANSIT CONNECT (P65_, P70_, P80_)</b>			<b>06/2002 → 12/2013</b>		
Belt Pulley, crankshaft	1.8 Di, 1.8 TDCi		<b>F8-7649</b>		
<b>TRANSIT CUSTOM Box</b>			<b>04/2012 →</b>		
Alternator Freewheel Clutch	2.2 TDCi		<b>F5-1125</b>		
Top Strut Mounting	2.2 TDCi		<b>F8-7456</b>		
Anti-Friction Bearing	2.2 TDCi		<b>F8-7609</b>		
<b>TRANSIT CUSTOM Bus</b>			<b>04/2012 →</b>		
Alternator Freewheel Clutch	2.2 TDCi		<b>F5-1125</b>		
Top Strut Mounting	2.2 TDCi		<b>F8-7456</b>		
Anti-Friction Bearing	2.2 TDCi		<b>F8-7609</b>		
<b>TRANSIT TOURNEO</b>			<b>07/2006 → 08/2014</b>		
Alternator Freewheel Clutch	All Models		<b>F5-1101</b>		
Alternator Freewheel Clutch	All Models		<b>F5-1125</b>		
Control Arm-/Trailing Arm Bush	2.2 TDCi		<b>F8-6162</b>		H1=40; H2=72; d=16.5; D=66
Control Arm-/Trailing Arm Bush	2.2 TDCi		<b>F8-6163</b>		H=67; d=14; D1=37; D2=44
Belt Pulley, crankshaft	2.2 TDCi	Number of Ribs: 3, 5; Parameter: 6 PK + 4 PK	<b>F8-6571</b>		Bore Ø [mm]=13; H=50; D=167
Top Strut Mounting	All Models		<b>F8-7456</b>		
Anti-Friction Bearing	All Models		<b>F8-7609</b>		
<b>TRANSIT Bus</b>			<b>08/2013 →</b>		
Alternator Freewheel Clutch	2.2 TDCi, 2.2 TDCi [RWD], 2.4 TDCi, 2.4 TDCi 4x4, 3.2 TDCi		<b>F5-1101</b>		
<b>TRANSIT Box</b>			<b>08/2013 →</b>		
Alternator Freewheel Clutch	2.2 TDCi, 2.2 TDCi [RWD], 2.2 TDCi 4x4, 2.4 TDCi, 2.4 TDCi 4x4, 3.2 TDCi		<b>F5-1101</b>		
Alternator Freewheel Clutch	2.2 TDCi, 2.2 TDCi [RWD], 2.2 TDCi 4x4, 2.4 TDCi, 2.4 TDCi 4x4, 3.2 TDCi		<b>F5-1125</b>		
<b>TRANSIT Platform/Chassis</b>			<b>08/2013 →</b>		
Alternator Freewheel Clutch	2.2 TDCi, 2.2 TDCi [RWD], 2.2 TDCi 4x4, 2.4 TDCi, 2.4 TDCi 4x4, 3.2 TDCi		<b>F5-1101</b>		
Alternator Freewheel Clutch	2.2 TDCi, 2.2 TDCi [RWD], 2.2 TDCi 4x4, 2.4 TDCi, 2.4 TDCi 4x4, 3.2 TDCi		<b>F5-1125</b>		
<b>PROBE [USA] Hatchback</b>			<b>01/1993 → 12/1997</b>		
Top Strut Mounting	2.0	with add-on material	<b>F8-7438</b>		



**Article Description****Article Nr.****Fitting Position**

<b>ACCORD Mk IV (CB)</b>			<b>01/1990 → 03/1993</b>	
Repair Kit, suspension strut	1.8, 2.0 16V, 2.0 i 16V, 2.2 i 16V, 2.2 i 16V Automatik		<b>F8-5949</b>	
Bellow, steering	2.2 i 16V, 2.2 i 16V Automatik	with clamps	<b>LM-10046S</b>	⊕ ⊕ d1=9; d2=44; L [mm]=160
Bellow, steering	2.0 16V, 2.0 i 16V, 2.2 i 16V, 2.2 i 16V Automatik	with clamps	<b>LM-10086S</b>	⊕ d1=9; d2=44; L [mm]=160
<b>ACCORD Mk IV Estate (CB)</b>			<b>01/1991 → 12/1993</b>	
Bellow, steering	2.0 i 16V, 2.2 i 16V	with clamps	<b>LM-10046S</b>	⊕ ⊕ d1=9; d2=44; L [mm]=160
Bellow, steering	2.0 i 16V, 2.2 i 16V	with clamps	<b>LM-10086S</b>	⊕ d1=9; d2=44; L [mm]=160
<b>ACCORD Mk IV Coupe (CB, CC)</b>			<b>01/1992 → 09/1993</b>	
Bellow, steering	All Models	with clamps	<b>LM-10086S</b>	⊕ d1=9; d2=44; L [mm]=160
<b>ACCORD Mk V (CC, CD)</b>			<b>03/1993 → 01/1996</b>	
Repair Kit, suspension strut	2.0 i S		<b>F8-5949</b>	
Bellow, steering	2.0 i, 2.0 i S, 2.3 i SR	with clamps	<b>LM-10046S</b>	⊕ ⊕ d1=9; d2=44; L [mm]=160
Bellow, steering	2.0 i, 2.3 i SR	with clamps	<b>LM-10086S</b>	⊕ d1=9; d2=44; L [mm]=160
<b>ACCORD Mk V Estate (CE)</b>			<b>09/1993 → 02/1998</b>	
Control Arm-/Trailing Arm Bush	All Models	05/1994 →	<b>F8-5278</b>	⊕ ⊕ ⊕ ↓
Repair Kit, suspension strut	All Models		<b>F8-5949</b>	
Bellow, steering	2.0 i LS 16V	with clamps	<b>LM-10046S</b>	⊕ ⊕ ⊕ d1=9; d2=44; L [mm]=160
<b>ACCORD Mk V Coupe (CD)</b>			<b>09/1993 → 02/1998</b>	
Control Arm-/Trailing Arm Bush	2.0		<b>F8-5278</b>	⊕ ⊕ ⊕ ↓
Control Arm-/Trailing Arm Bush	2.2 i ES	05/1994 →	<b>F8-5278</b>	⊕ ⊕ ⊕ ↓
Bellow, steering	All Models	with clamps	<b>LM-10046S</b>	⊕ ⊕ d1=9; d2=44; L [mm]=160
<b>ACCORD Mk VI (CE, CF)</b>			<b>02/1996 → 10/1998</b>	
Control Arm-/Trailing Arm Bush	1.9 i	03/1996 →	<b>F8-5278</b>	⊕ ⊕ ⊕ ↓
Repair Kit, suspension strut	2.0 i LS		<b>F8-5949</b>	
Bellow, steering	1.9 i, 2.0 i LS	with clamps	<b>LM-10086S</b>	⊕ ⊕ d1=9; d2=44; L [mm]=160
<b>ACCORD Mk VII (CG, CK)</b>			<b>10/1998 → 06/2003</b>	
Control Arm-/Trailing Arm Bush	1.6 i, 1.8 i, 2.0 i, 2.0 Turbo DI, 2.2 Type-R, 2.3		<b>F8-5278</b>	⊕ ⊕ ⊕ ↓
Control Arm-/Trailing Arm Bush	1.6 i, 1.8 i, 2.0 i, 2.0 Turbo DI, 2.2 Type-R, 2.3		<b>F8-5279</b>	⊕ ⊕ ⊕ ↓ d=12,2; D=42; L [mm]=52
<b>ACCORD Mk VII Estate (CF)</b>			<b>02/1998 →</b>	
Control Arm-/Trailing Arm Bush	2.3 16 V		<b>F8-5278</b>	⊕ ⊕ ⊕ ↓



Article Description



Article Nr.

Fitting Position



Article Description		Article Nr.	Fitting Position	02/1998 →
<b>ACCORD Mk VII Estate (CF)</b>				
Control Arm-/Trailing Arm Bush	2.3 16 V	F8-5279	⊕ ⊕ ↓	d=12,2; D=42; L [mm]=52
<b>ACCORD Mk VII Coupe (CG)</b>				
Control Arm-/Trailing Arm Bush	2.0 i 16V, 3.0 V6 24V	F8-5278	⊕ ⊕ ↓	
Control Arm-/Trailing Arm Bush	2.0 i 16V, 3.0 V6 24V	F8-5279	⊕ ⊕ ↓	d=12,2; D=42; L [mm]=52
<b>ACCORD Mk VII Hatchback (CH)</b>				
Control Arm-/Trailing Arm Bush	1.8 i , 2.0 , 2.0 TDi	F8-5278	⊕ ⊕ ↓	
Control Arm-/Trailing Arm Bush	2.3	F8-5278	⊕ ⊕ ↓	07/2001 →
Control Arm-/Trailing Arm Bush	1.8 i	F8-5279	⊕ ⊕ ↓	d=12,2; D=42; L [mm]=52
<b>ACCORD VII (CL)</b>				
02/2003 → 05/2008				
Dust Cover Kit, shock absorber	2.0 , 2.0 All-wheel Drive , 2.2 i-CTDi, 2.4	AK-735206	⊕ ⊕	
Dust Cover Kit, shock absorber	2.0 , 2.0 All-wheel Drive , 2.2 i-CTDi, 2.4	AK-735207	⊕ ⊕	
Alternator Freewheel Clutch	2.2 i-CTDi	F5-1136		
Control Arm-/Trailing Arm Bush	2.0 All-wheel Drive	F8-5278	⊕ ⊕ ↓	
<b>ACCORD VII Tourer (CM)</b>				
04/2003 → 05/2008				
Dust Cover Kit, shock absorber	All Models	AK-735206	⊕ ⊕	
Dust Cover Kit, shock absorber	All Models	AK-735208	⊕ ⊕	
Alternator Freewheel Clutch	2.2 i-CTDi	F5-1136		
<b>ACCORD VIII (CU)</b>				
07/2008 → 06/2015				
Alternator Freewheel Clutch	2.2 i-DTEC	F5-1136		
Alternator Freewheel Clutch	2.2 i-DTEC	F5-1143		
<b>ACCORD VIII Estate</b>				
07/2008 →				
Alternator Freewheel Clutch	2.2 i-DTEC	F5-1136		
Alternator Freewheel Clutch	2.2 i-DTEC	F5-1143		
<b>CIVIC III Saloon (AM, AK, AU)</b>				
01/1985 → 10/1987				
Repair Kit, suspension strut	1.2	F8-5949		
<b>CIVIC Mk III Hatchback (EC, ED, EE)</b>				
09/1987 → 12/1991				
Repair Kit, suspension strut	1.2, 1.3 , 1.3 16 V , 1.4 L , 1.5, 1.5 i 16V, 1.6 i 16V , 1.6 i 16V Vtec	F8-5949		
Control Arm-/Trailing Arm Bush	1.3 , 1.3 16 V , 1.4 L , 1.5 i 16V , 1.6 i 16V , 1.6 i 16V Vtec	F8-5981	⊕ ⊕	H=50; d=10; D=37

<b>AK-735206</b>	<b>AK-735207</b>	<b>AK-735208</b>	<b>F5-1136</b>	<b>F5-1143</b>	<b>F8-5278</b>	<b>F8-5279</b>
Ref.Nr.: 51688SDAA01	Ref.Nr.: 52688S0A004	Ref.Nr.: 52687S70004	Ref.Nr.: 31141-RBD-E02	Ref.Nr.: 31141-RL0-G01	Ref.Nr.: 51393-SL5-013	Ref.Nr.: 51810SM4004
<b>F8-5949</b>	<b>F8-5981</b>	<b>F8-5982</b>				
Ref.Nr.: 51631SB0004	Ref.Nr.: 52622-SH3-010	Ref.Nr.: 52365-SH3-000				

**Article Description****Article Nr.****Fitting Position**

<b>CIVIC Mk III Hatchback (EC, ED, EE)</b>			<b>09/1987 → 12/1991</b>		
Control Arm-/Trailing Arm Bush	1.3, 1.3 16V, 1.4 L, 1.5 i 16V, 1.6 i 16V, 1.6 i 16V Vtec		<b>F8-5982</b>		H=50; d=10; D=31
Control Arm-/Trailing Arm Bush	1.3 16V, 1.5 i 16V, 1.6 i 16V, 1.6 i 16V Vtec		<b>F8-5988</b>		D=80
Control Arm-/Trailing Arm Bush	1.3, 1.3 16V, 1.4 L, 1.5, 1.5 i 16V, 1.6 i 16V, 1.6 i 16V Vtec		<b>F8-6073</b>		H=50; d=12; D=37
Bellow, steering	1.5 i 16V	with clamps;	<b>LM-10046S</b>		d1=9; d2=44; L [mm]=160
Bellow, steering	1.6 i 16V, 1.6 i 16V Vtec	with clamps	<b>LM-10086S</b>		d1=9; d2=44; L [mm]=160
<b>CIVIC Mk III Saloon (ED)</b>			<b>09/1987 → 12/1991</b>		
Repair Kit, suspension strut	1.2, 1.3, 1.4 L, 1.5, 1.5 i 16V, 1.6, 1.6 4x4, 1.6 i 16V, 1.6 i 16V 4x4		<b>F8-5949</b>		
Control Arm-/Trailing Arm Bush	1.4 L, 1.5 i 16V, 1.6 i 16V, 1.6 i 16V 4x4		<b>F8-5981</b>		H=50; d=10; D=37
Control Arm-/Trailing Arm Bush	1.4 L, 1.5 i 16V, 1.6 i 16V		<b>F8-5982</b>		H=50; d=10; D=31
Control Arm-/Trailing Arm Bush	1.5 i 16V, 1.6 i 16V, 1.6 i 16V 4x4		<b>F8-5988</b>		D=80
Control Arm-/Trailing Arm Bush	1.2, 1.4 L, 1.5, 1.5 i 16V, 1.6, 1.6 4x4, 1.6 i 16V		<b>F8-6073</b>		H=50; d=12; D=37
Bellow, steering	1.6 i 16V, 1.6 i 16V 4x4	with clamps	<b>LM-10086S</b>		d1=9; d2=44; L [mm]=160
<b>CIVIC Mk II Estate (EE)</b>			<b>01/1988 → 02/1995</b>		
Repair Kit, suspension strut	1.8		<b>F8-5949</b>		
Control Arm-/Trailing Arm Bush	1.5 i 16V, 1.6 i 16V 4WD		<b>F8-5981</b>		H=50; d=10; D=37
Control Arm-/Trailing Arm Bush	1.5 i 16V, 1.6 i 16V 4WD		<b>F8-5988</b>		D=80
<b>CIVIC Mk IV Coupe (EJ)</b>			<b>08/1993 → 03/1996</b>		
Stabiliser Mounting	All Models		<b>F8-5294</b>		
Control Arm-/Trailing Arm Bush	1.5 i LSi, 1.6 i Vtec		<b>F8-5981</b>		H=50; d=10; D=37
Control Arm-/Trailing Arm Bush	1.5 i LSi, 1.6 i Vtec		<b>F8-5982</b>		H=50; d=10; D=31
Control Arm-/Trailing Arm Bush	All Models		<b>F8-5988</b>		D=80
Control Arm-/Trailing Arm Bush	1.5 i LSi, 1.6 i, 1.6 i Vtec		<b>F8-6073</b>		H=50; d=12; D=37
Engine Mounting	1.6 i Vtec		<b>F8-8159</b>		
Engine Mounting	1.6 i Vtec		<b>F8-8160</b>		
Bellow, steering	All Models	with clamps	<b>LM-10046S</b>		d1=9; d2=44; L [mm]=160
Bellow, steering	All Models	with clamps	<b>LM-10086S</b>		d1=9; d2=44; L [mm]=160

<b>F8-5294</b>	<b>F8-5949</b>	<b>F8-5981</b>	<b>F8-5982</b>	<b>F8-5988</b>	<b>F8-6073</b>	<b>F8-8159</b>
Ref.Nr.: 51312SR3000	Ref.Nr.: 51631SB0004	Ref.Nr.: 52622-SH3-010	Ref.Nr.: 52365-SH3-000	Ref.Nr.: RGX100980	Ref.Nr.: 51392-SR3-024	Ref.Nr.: 50842-SR3-030
<b>F8-8160</b>	<b>LM-10046S</b>	<b>LM-10086S</b>				
Ref.Nr.: 50841-SR3-984	Ref.Nr.: 48204-53A00	Ref.Nr.: 53534-SR3-N52				

Article Description



Article Nr.

Fitting Position



<b>CIVIC Mk IV Hatchback (EG)</b>			<b>10/1991 → 11/1995</b>		
Stabiliser Mounting	1.3 16V , 1.5 i 16V , 1.6 16V Vtec , 1.6 VTi 16V		<b>F8-5294</b>		
Repair Kit, suspension strut	1.3 16V , 1.5 i 16V , 1.6 16V Vtec , 1.6 VTi 16V		<b>F8-5949</b>		
Control Arm-/Trailing Arm Bush	1.3 16V , 1.5 i 16V , 1.6 16V Vtec , 1.6 VTi 16V		<b>F8-5981</b>		H=50; d=10; D=37
Control Arm-/Trailing Arm Bush	1.3 16V , 1.5 i 16V , 1.6 16V Vtec , 1.6 VTi 16V		<b>F8-5982</b>		H=50; d=10; D=31
Control Arm-/Trailing Arm Bush	1.3 16V , 1.5 i 16V , 1.6 16V Vtec , 1.6 VTi 16V		<b>F8-5988</b>		D=80
Control Arm-/Trailing Arm Bush	1.3 16V , 1.5 i 16V , 1.6 16V Vtec , 1.6 VTi 16V		<b>F8-6073</b>		H=50; d=12; D=37
Control Arm-/Trailing Arm Bush	1.3 16V , 1.5 i 16V , 1.6 16V Vtec , 1.6 VTi 16V		<b>F8-8005</b>		
Bellow, steering	1.3 16V	with clamps;	<b>LM-10046S</b>		d1=9; d2=44; L [mm]=160
Bellow, steering	1.5 i 16V , 1.6 16V Vtec , 1.6 VTi 16V	with clamps	<b>LM-10046S</b>		d1=9; d2=44; L [mm]=160
Bellow, steering	1.3 16V , 1.5 i 16V , 1.6 16V Vtec , 1.6 VTi 16V	with clamps	<b>LM-10086S</b>		d1=9; d2=44; L [mm]=160
<b>CIVIC Mk IV Saloon (EG, EH)</b>			<b>10/1991 → 12/1995</b>		
Stabiliser Mounting	1.5 i 16V , 1.6 16V Vtec , 1.6 VTi		<b>F8-5294</b>		
Repair Kit, suspension strut	1.3, 1.5, 1.5 i 16V , 1.6 16V Vtec , 1.6 4x4, 1.6 EX, 1.6 VTi		<b>F8-5949</b>		
Control Arm-/Trailing Arm Bush	1.5 i 16V , 1.6 16V Vtec , 1.6 VTi		<b>F8-5981</b>		H=50; d=10; D=37
Control Arm-/Trailing Arm Bush	1.5 i 16V , 1.6 16V Vtec , 1.6 VTi		<b>F8-5982</b>		H=50; d=10; D=31
Control Arm-/Trailing Arm Bush	1.5 i 16V , 1.6 16V Vtec , 1.6 VTi		<b>F8-5988</b>		D=80
Control Arm-/Trailing Arm Bush	1.3, 1.5, 1.5 i 16V , 1.6 16V Vtec , 1.6 4x4, 1.6 EX, 1.6 VTi		<b>F8-6073</b>		H=50; d=12; D=37
Control Arm-/Trailing Arm Bush	1.3, 1.5, 1.5 i 16V , 1.6 16V Vtec , 1.6 EX, 1.6 VTi		<b>F8-8005</b>		
Bellow, steering	1.5 i 16V , 1.6 16V Vtec , 1.6 VTi	with clamps	<b>LM-10086S</b>		d1=9; d2=44; L [mm]=160
<b>CIVIC Mk V Estate (MB, MC)</b>			<b>04/1998 → 02/2001</b>		
Control Arm-/Trailing Arm Bush	1.4 16V , 1.5 16V , 1.6 16V , 1.8 16V		<b>F8-5988</b>		D=80
Bellow, steering	1.4 16V , 1.5 16V , 1.6 16V , 1.8 16V , 2.0 i D	with clamps	<b>LM-10086S</b>		d1=9; d2=44; L [mm]=160
<b>CIVIC VI Coupe (EJ, EM1)</b>			<b>03/1996 → 12/2000</b>		
Repair Kit, suspension strut	1.6 i, 1.6 i Vtec		<b>F8-5949</b>		
Stabiliser Mounting	1.6 i Vtec		<b>F8-8029</b>		d=25
Engine Mounting	1.6, 1.6 i, 1.6 i Vtec		<b>F8-8159</b>		
Engine Mounting	1.6 i, 1.6 i Vtec		<b>F8-8160</b>		
Bellow, steering	1.6 i Vtec	with clamps	<b>LM-10046S</b>		d1=9; d2=44; L [mm]=160

<b>F8-5294</b>	<b>F8-5949</b>	<b>F8-5981</b>	<b>F8-5982</b>	<b>F8-5988</b>	<b>F8-6073</b>	<b>F8-8005</b>
Ref.Nr.: 51312SR3000	Ref.Nr.: 51631SB0004	Ref.Nr.: 52622-SH3-010	Ref.Nr.: 52365-SH3-000	Ref.Nr.: RGX100980	Ref.Nr.: 51392-SR3-024	Ref.Nr.: 51395-SR3-N02
<b>F8-8029</b>	<b>F8-8159</b>	<b>F8-8160</b>	<b>LM-10046S</b>	<b>LM-10086S</b>		
Ref.Nr.: 51306-S04-N01	Ref.Nr.: 50842-SR3-030	Ref.Nr.: 50841-SR3-984	Ref.Nr.: 48204-53A00	Ref.Nr.: 53534-SR3-N52		

**Article Description****Article Nr.****Fitting Position**

<b>CIVIC VI Coupe (EJ, EM1)</b>				<b>03/1996 → 12/2000</b>	
Bellow, steering	1.6 i, 1.6 i Vtec	with clamps	<b>LM-10086S</b>		d1=9; d2=44; L [mm]=160
<b>CIVIC Mk IV Hatchback (MA, MB)</b>				<b>09/1994 → 02/2001</b>	
Stabiliser Mounting	1.4 i, 1.5 i Vtec-E, 1.6 i, 1.6 i Vtec		<b>F8-5294</b>		
Repair Kit, suspension strut	1.6 VTi		<b>F8-5949</b>		
Control Arm-/Trailing Arm Bush	1.4 i, 1.5 16V, 1.5 i Vtec-E, 1.6 16V, 1.6 i, 1.6 i Vtec, 1.8 16V, 2.0 i TD		<b>F8-5988</b>		D=80
Bellow, steering	1.4 i, 1.5 i Vtec-E, 1.6 i, 1.6 i Vtec	with clamps	<b>LM-10046S</b>		d1=9; d2=44; L [mm]=160
Bellow, steering	1.4 i, 1.5 16V, 1.5 i Vtec-E, 1.6 16V, 1.6 i, 1.6 i Vtec, 1.6 VTi, 1.8 16V, 2.0 i TD	with clamps	<b>LM-10086S</b>		d1=9; d2=44; L [mm]=160
<b>CIVIC Mk V Hatchback (EJ, EK)</b>				<b>11/1995 → 02/2001</b>	
Repair Kit, suspension strut	1.4 i, 1.4 i S, 1.5 i, 1.6 VTi		<b>F8-5949</b>		
Control Arm-/Trailing Arm Bush	1.4 i, 1.4 i S, 1.5 i, 1.6 VTi		<b>F8-5988</b>		D=80
Control Arm-/Trailing Arm Bush	1.4 i, 1.4 i S, 1.5 i, 1.6 i, 1.6 VTi		<b>F8-8027</b>		d=18
Stabiliser Mounting	1.6 VTi		<b>F8-8029</b>		d=25
Engine Mounting	1.4 i, 1.4 i S, 1.5 i, 1.6 VTi		<b>F8-8159</b>		
Engine Mounting	1.4 i, 1.4 i S, 1.5 i, 1.6 VTi		<b>F8-8160</b>		
Bellow, steering	1.4 i, 1.4 i S, 1.5 i, 1.6 i, 1.6 VTi	with clamps	<b>LM-10086S</b>		d1=9; d2=44; L [mm]=160
<b>CIVIC Mk V Saloon (EJ, EK)</b>				<b>10/1995 → 02/2001</b>	
Repair Kit, suspension strut	1.4, 1.4 i, 1.5 i, 1.6 VTi		<b>F8-5949</b>		
Control Arm-/Trailing Arm Bush	1.4, 1.4 i, 1.5 i, 1.6 VTi		<b>F8-8027</b>		d=18
Stabiliser Mounting	1.6 VTi		<b>F8-8029</b>		d=25
Engine Mounting	1.4, 1.4 i, 1.5 i, 1.6 VTi		<b>F8-8159</b>		
Engine Mounting	1.4, 1.4 i, 1.5 i, 1.6 VTi		<b>F8-8160</b>		
Bellow, steering	1.4, 1.6	with clamps	<b>LM-10046S</b>		d1=9; d2=44; L [mm]=160
Bellow, steering	1.4 i, 1.5 i, 1.6 i Vtec, 1.6 VTi	with clamps	<b>LM-10086S</b>		d1=9; d2=44; L [mm]=160
<b>CIVIC VII Coupe (EM2)</b>				<b>02/2001 → 12/2005</b>	
Dust Cover Kit, shock absorber	All Models		<b>AK-735204</b>		
Top Strut Mounting	All Models		<b>F8-7462</b>		
<b>CIVIC VII Hatchback (EU, EP, EV)</b>				<b>01/2000 → 09/2005</b>	
Dust Cover Kit, shock absorber	1.4 i, 1.4 i S, 1.6 i, 1.7 CTDi, 2.0 i Sport, 2.0 Type-R		<b>AK-735131</b>		
Dust Cover Kit, shock absorber	All Models		<b>AK-735204</b>		
Top Strut Mounting	1.4 i, 1.4 i S, 1.6 i, 1.7, 1.7 CTDi, 2.0 i Sport		<b>F8-7462</b>		
Control Arm-/Trailing Arm Bush	1.4 i, 1.4 i S, 1.6 i		<b>F8-8028</b>		d=14; D=42

<b>AK-735131</b>	<b>AK-735204</b>	<b>F8-5294</b>	<b>F8-5949</b>	<b>F8-5988</b>	<b>F8-7462</b>	<b>F8-8027</b>
Ref.Nr.:	Ref.Nr.: 52687S5A014	Ref.Nr.: 51312SR3000	Ref.Nr.: 51631SB0004	Ref.Nr.: RGX100980	Ref.Nr.: 51920-S6M-J02	Ref.Nr.: 51391-S04-005
<b>F8-8028</b>	<b>F8-8029</b>	<b>F8-8159</b>	<b>F8-8160</b>	<b>LM-10046S</b>	<b>LM-10086S</b>	
Ref.Nr.: 51392-S5A-004	Ref.Nr.: 51306-S04-N01	Ref.Nr.: 50842-SR3-030	Ref.Nr.: 50841-SR3-984	Ref.Nr.: 48204-53A00	Ref.Nr.: 53534-SR3-N52	

Article Description

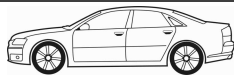

Article Nr.

Fitting Position



<b>CIVIC VII Saloon (ES)</b>		<b>12/2000 → 09/2005</b>	
Dust Cover Kit, shock absorber	1.4 , 1.6	AK-735131	
Dust Cover Kit, shock absorber	1.3 IMA	AK-735203	
Dust Cover Kit, shock absorber	1.2, 1.3 IMA, 1.4 , 1.6, 1.7 , 1.8, 2.0	AK-735204	
Top Strut Mounting	1.2, 1.3 IMA, 1.4 , 1.6, 1.8	F8-7462	
Stabiliser Mounting	1.3 IMA	F8-8031	d=25
<b>CIVIC VIII Hatchback (FN, FK)</b>		<b>09/2005 →</b>	
Dust Cover Kit, shock absorber	1.4, 1.6, 1.8, 2.2 CTDi	AK-735205	
Alternator Freewheel Clutch	2.2 CTDi	F5-1136	
<b>CIVIC VIII Saloon (FD, FA)</b>		<b>09/2005 → 02/2012</b>	
Dust Cover Kit, shock absorber	1.3 Hybrid, 1.6, 1.8	AK-735205	
<b>CIVIC IX (FK)</b>		<b>02/2012 →</b>	
Alternator Freewheel Clutch	1.6 i-DTEC, 2.2 i-DTEC	F5-1143	
<b>CIVIC IX Saloon (FB, FG)</b>		<b>02/2012 →</b>	
Alternator Freewheel Clutch	1.8	F5-1143	
<b>CONCERTO (HW, MA)</b>		<b>08/1989 → 03/1995</b>	
Control Arm-/Trailing Arm Bush	1.4, 1.5 i 16V, 1.6 16V, 1.6 i 16V	F8-5123	H1=50; H2=30; d=10; D=32
Control Arm-/Trailing Arm Bush	1.4, 1.5 i 16V, 1.6 16V, 1.6 i 16V	F8-5988	D=80
<b>CONCERTO Saloon (HWW)</b>		<b>08/1989 → 05/1995</b>	
Control Arm-/Trailing Arm Bush	1.4, 1.5 i 16V, 1.6 16V, 1.6 i 16V	F8-5123	H1=50; H2=30; d=10; D=32
Control Arm-/Trailing Arm Bush	1.4, 1.5 i 16V, 1.6 16V, 1.6 i 16V	F8-5988	D=80
<b>CR-V I (RD)</b>		<b>10/1995 → 02/2002</b>	
Repair Kit, suspension strut	All Models	F8-5949	
Control Arm-/Trailing Arm Bush	All Models	F8-8027	d=18
Stabiliser Mounting	All Models	F8-8029	d=25
Engine Mounting	All Models	F8-8160	
Bellow, steering	2.0, 2.0 16V	LM-10046S	d1=9; d2=44; L [mm]=160
Bellow, steering	2.0, 2.0 16V	LM-10046S	d1=9; d2=44; L [mm]=160
<b>CR-V Mk II (RD_)</b>		<b>09/2001 → 09/2006</b>	
Dust Cover Kit, shock absorber	All Models	AK-735211	
Dust Cover Kit, shock absorber	All Models	AK-735212	
Alternator Freewheel Clutch	2.2 CTDi	F5-1136	



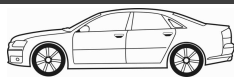

**Article Description****Article Nr.****Fitting Position**

<b>CR-V Mk II (RD_)</b>			<b>09/2001 → 09/2006</b>	
Top Strut Mounting	2.0		<b>F8-7462</b>	
Control Arm-/Trailing Arm Bush	2.0, 2.2 CTDi		<b>F8-8028</b>	d=14; D=42
Stabiliser Mounting	2.0		<b>F8-8030</b>	d=18
Stabiliser Mounting	2.0, 2.2 CTDi		<b>F8-8031</b>	d=25
<b>CR-V Mk III (RE)</b>			<b>01/2007 →</b>	
Alternator Freewheel Clutch	2.2 i-CTDi 4WD, 2.2 i-DTEC 4WD		<b>F5-1136</b>	
Alternator Freewheel Clutch	2.2 i-CTDi 4WD, 2.2 i-DTEC 4WD		<b>F5-1143</b>	
<b>CR-V IV (RE)</b>			<b>10/2012 →</b>	
Alternator Freewheel Clutch	1.6 i-DTEC, 2.2 i-DTEC AWD		<b>F5-1143</b>	
<b>CRX Mk II (ED, EE)</b>			<b>10/1987 → 02/1992</b>	
Repair Kit, suspension strut	All Models		<b>F8-5949</b>	
Control Arm-/Trailing Arm Bush	1.6 i 16V, 1.6 i 16V Vtec		<b>F8-5981</b>	H=50; d=10; D=37
Control Arm-/Trailing Arm Bush	1.6 i 16V, 1.6 i 16V Vtec		<b>F8-5982</b>	H=50; d=10; D=31
Control Arm-/Trailing Arm Bush	All Models		<b>F8-6073</b>	H=50; d=12; D=37
<b>CRX Mk III (EH, EG)</b>			<b>03/1992 → 12/1998</b>	
Stabiliser Mounting	1.6 ESi, 1.6 i VTi		<b>F8-5294</b>	
Repair Kit, suspension strut	1.6 ESi		<b>F8-5949</b>	
Control Arm-/Trailing Arm Bush	1.6 ESi, 1.6 i VTi		<b>F8-5981</b>	H=50; d=10; D=37
Control Arm-/Trailing Arm Bush	1.6 ESi, 1.6 i VTi		<b>F8-5982</b>	H=50; d=10; D=31
Control Arm-/Trailing Arm Bush	1.6 ESi, 1.6 i VTi		<b>F8-5988</b>	D=80
Control Arm-/Trailing Arm Bush	1.6 ESi, 1.6 i VTi		<b>F8-6073</b>	H=50; d=12; D=37
Engine Mounting	All Models		<b>F8-8159</b>	
Bellow, steering	1.6 ESi, 1.6 i VTi	with clamps	<b>LM-10086S</b>	d1=9; d2=44; L [mm]=160
<b>CR-Z (ZF1)</b>			<b>06/2010 →</b>	
Anti-Friction Bearing	1.5 Hybrid		<b>F8-6266</b>	
<b>FR-V (BE)</b>			<b>02/2005 →</b>	
Alternator Freewheel Clutch	2.2 i CTDi		<b>F5-1136</b>	
Stabiliser Mounting	1.8, 2.0, 2.2 i CTDi		<b>F8-8031</b>	d=25

<b>AK-735209</b>	<b>F5-1136</b>	<b>F5-1143</b>	<b>F8-5294</b>	<b>F8-5949</b>	<b>F8-5981</b>	<b>F8-5982</b>
Ref.Nr.: 51722S2H014	Ref.Nr.: 31141-RBD-E02	Ref.Nr.: 31141-RL0-G01	Ref.Nr.: 51312SR3000	Ref.Nr.: 51631SB0004	Ref.Nr.: 52622-SH3-010	Ref.Nr.: 52365-SH3-000
<b>F8-5988</b>	<b>F8-6073</b>	<b>F8-6266</b>	<b>F8-7462</b>	<b>F8-8028</b>	<b>F8-8030</b>	<b>F8-8031</b>
Ref.Nr.: RGX100980	Ref.Nr.: 51392-SR3-024	Ref.Nr.: 5035C2	Ref.Nr.: 51920-S6M-J02	Ref.Nr.: 51392-S5A-004	Ref.Nr.: 52306-S9A-005	Ref.Nr.: 51306-S7B-014
<b>F8-8159</b>	<b>LM-10086S</b>					
Ref.Nr.: 50842-SR3-030	Ref.Nr.: 53534-SR3-N52					

Article Description



Article Nr.

Fitting Position



Article Description		Article Nr.	Fitting Position	Period
<b>HR-V (GH)</b>				<b>03/1999 →</b>
Dust Cover Kit, shock absorber	All Models	AK-735209		
Dust Cover Kit, shock absorber	All Models	AK-735210		
Engine Mounting	1.6 16V, 1.6 16V 4WD	F8-8160		
<b>INSIGHT (ZE_)</b>				<b>04/2009 →</b>
Anti-Friction Bearing	1.3 Hybrid	F8-6266		
<b>JAZZ II (GD)</b>				<b>03/2002 → 07/2008</b>
Anti-Friction Bearing	1.2, 1.4	F8-6266		
<b>JAZZ III (GE)</b>				<b>04/2011 →</b>
Anti-Friction Bearing	1.3 HYBRID	F8-6266		
<b>PRELUDE Mk IV (BB)</b>				<b>02/1992 → 09/1996</b>
Control Arm-/Trailing Arm Bush	2.0 i 16V , 2.3 i 16V	F8-5278	   	
Control Arm-/Trailing Arm Bush	2.2 i 16V Vtec	F8-5278	   	11/1993 →
Bellow, steering	2.2 i 16V Vtec , 2.3 i 16V	LM-10046S		d1=9; d2=44; L [mm]=160
<b>PRELUDE Mk V (BB)</b>				<b>10/1996 → 10/2000</b>
Control Arm-/Trailing Arm Bush	2.0 16V , 2.2 16V	F8-5278	   	
Control Arm-/Trailing Arm Bush	2.2 16V	F8-5278	   	10/1998 →
Bellow, steering	All Models	LM-10046S		d1=9; d2=44; L [mm]=160
<b>SHUTTLE (RA)</b>				<b>10/1994 → 06/2004</b>
Control Arm-/Trailing Arm Bush	2.2 16V	F8-5278	   	06/1995 →
Control Arm-/Trailing Arm Bush	2.3 16V	F8-5278	   	11/1997 →
Bellow, steering	2.2 16V, 2.3 16V	LM-10046S		d1=9; d2=44; L [mm]=160
<b>STREAM (RN)</b>				<b>05/2001 →</b>
Stabiliser Mounting	All Models	F8-8031		d=25
<b>ACCORD VII (CM)</b>				<b>09/2002 → 12/2005</b>
Dust Cover Kit, shock absorber	All Models	AK-735206	 	
Dust Cover Kit, shock absorber	All Models	AK-735207	 	



**Article Description****Article Nr.****Fitting Position**

<b>ACCENT I (X-3)</b>			<b>10/1994 → 01/2000</b>		
Dust Cover Kit, shock absorber	1.3, 1.3 i 12V, 1.5 i 12V, 1.5 i 16V		<b>AK-735011</b>		
Stabiliser Mounting	1.3, 1.3 i 12V, 1.5 i 12V, 1.5 i 16V	11/1996 →	<b>F8-7827</b>		d=14,5
<b>ACCENT Saloon (X-3)</b>			<b>10/1994 → 01/2000</b>		
Dust Cover Kit, shock absorber	1.3, 1.3 i 12V, 1.5 i 12V, 1.5 i 16V		<b>AK-735011</b>		
Stabiliser Mounting	1.3, 1.3 i 12V, 1.5 i 12V, 1.5 i 16V	11/1996 →	<b>F8-7827</b>		d=14,5
<b>ACCENT II (LC)</b>			<b>01/2000 → 11/2005</b>		
Alternator Freewheel Clutch	1.5 CRDi		<b>F5-1124</b>		
Control Arm-/Trailing Arm Bush	1.3, 1.5, 1.5 CRDi, 1.6		<b>F8-7073</b>		d=12; L1=54; L2=31.5; D1=35; D2=34
Top Strut Mounting	1.3, 1.5, 1.5 CRDi, 1.6		<b>F8-7463</b>		
Control Arm-/Trailing Arm Bush	1.3, 1.5, 1.5 CRDi, 1.6		<b>F8-7817</b>		
Stabiliser Mounting	1.3, 1.5, 1.5 CRDi, 1.6		<b>F8-7826</b>		
Stabiliser Mounting	1.3, 1.5, 1.5 CRDi, 1.6		<b>F8-7827</b>		d=14,5
Belt Pulley, crankshaft	1.5 CRDi		<b>F8-7866</b>		
<b>ACCENT II Saloon (LC)</b>			<b>01/2000 → 11/2005</b>		
Alternator Freewheel Clutch	1.5 CRDi		<b>F5-1124</b>		
Control Arm-/Trailing Arm Bush	1.3, 1.5, 1.5 CRDi, 1.6		<b>F8-7073</b>		d=12; L1=54; L2=31.5; D1=35; D2=34
Top Strut Mounting	1.3, 1.5, 1.5 CRDi, 1.6		<b>F8-7463</b>		
Control Arm-/Trailing Arm Bush	1.3, 1.5, 1.5 CRDi, 1.6		<b>F8-7817</b>		
Stabiliser Mounting	1.3, 1.5, 1.5 CRDi, 1.6		<b>F8-7826</b>		
Stabiliser Mounting	1.3, 1.5, 1.5 CRDi, 1.6		<b>F8-7827</b>		d=14,5
Belt Pulley, crankshaft	1.5 CRDi		<b>F8-7866</b>		
<b>ACCENT III (MC)</b>			<b>11/2005 → 11/2010</b>		
Dust Cover Kit, shock absorber	All Models		<b>AK-735213</b>		
Dust Cover Kit, shock absorber	All Models		<b>AK-735214</b>		
Alternator Freewheel Clutch	1.5 CRDi GLS		<b>F5-1124</b>		
Control Arm-/Trailing Arm Bush	All Models		<b>F8-7067</b>		H=54; d=12,2; D=32,5
Control Arm-/Trailing Arm Bush	All Models		<b>F8-7822</b>		
Stabiliser Mounting	All Models		<b>F8-7829</b>		d=24; L=45
Belt Pulley, crankshaft	1.5 CRDi GLS		<b>F8-7866</b>		
<b>ACCENT III Saloon (MC)</b>			<b>11/2005 → 11/2010</b>		
Alternator Freewheel Clutch	1.5 CRDi GLS		<b>F5-1124</b>		

<b>AK-735011</b>	<b>AK-735213</b>	<b>AK-735214</b>	<b>F5-1124</b>	<b>F8-7067</b>	<b>F8-7073</b>	<b>F8-7463</b>
Ref.Nr.:	Ref.Nr.: 546251E100	Ref.Nr.: 553261E000	Ref.Nr.: 37322-27501	Ref.Nr.: 54551-07001	Ref.Nr.: 54551-25000	Ref.Nr.: 54610-22000
<b>F8-7817</b>	<b>F8-7822</b>	<b>F8-7826</b>	<b>F8-7827</b>	<b>F8-7829</b>	<b>F8-7866</b>	
Ref.Nr.: 54555-25000	Ref.Nr.: 54584-1G000	Ref.Nr.: 54813-25000	Ref.Nr.: 55513-22500	Ref.Nr.: 54812-1G100	Ref.Nr.: 23124-2A001	

Article Description



Article Nr.

Fitting Position



<b>ACCENT III Saloon (MC)</b>		11/2005 → 11/2010	
Control Arm-/Trailing Arm Bush	All Models	F8-7067	
Control Arm-/Trailing Arm Bush	All Models	F8-7822	
Stabiliser Mounting	All Models	F8-7829	
Belt Pulley, crankshaft	1.5 CRDi GLS	F8-7866	
<b>AMICA / ATOZ (MX)</b>		02/1998 → 05/2005	
Dust Cover Kit, shock absorber	1.0 i, 1.1	AK-735327	
Dust Cover Kit, shock absorber	1.0 i	AK-735328	
Dust Cover Kit, shock absorber	1.1	AK-735329	
Anti-Friction Bearing	1.0 i	F8-6366	
<b>AMICA (MX)</b>		08/1999 →	
Dust Cover Kit, shock absorber	All Models	AK-735327	
Dust Cover Kit, shock absorber	1.0 i	AK-735328	
Anti-Friction Bearing	1.0 i	F8-6366	
Rubber Buffer, suspension	All Models	F8-7443	H=106
<b>LANTRA (RD)</b>		08/1996 → 04/2002	
Top Strut Mounting	1.6 16V, 1.6 i 16V, 2.0 16V	F8-7370	
<b>LANTRA (GK)</b>		08/2001 → 08/2009	
Dust Cover Kit, shock absorber	1.6 16V, 2.0, 2.0 GLS, 2.7 V6	AK-735333	
Dust Cover Kit, shock absorber	1.6 16V, 2.0, 2.0 GLS, 2.7 V6	AK-735334	
Anti-Friction Bearing	All Models	F8-3012	H=20; d=66; D=100
<b>ELANTRA (XD)</b>		06/2000 → 07/2006	
Dust Cover Kit, shock absorber	1.6, 1.6 CRDi, 1.8, 2.0, 2.0 CRDi	AK-735335	
Dust Cover Kit, shock absorber	1.6, 1.6 CRDi, 1.8, 2.0, 2.0 CRDi	AK-735336	
Alternator Freewheel Clutch	2.0 CRDi	F5-1055	
Stabiliser Mounting	1.6, 1.6 CRDi, 1.8, 2.0, 2.0 CRDi	F8-7061	
Bearing Bush, stabiliser	1.6, 1.6 CRDi, 1.8, 2.0, 2.0 CRDi	F8-7063	
Control Arm-/Trailing Arm Bush	1.6 CRDi	F8-7070	
Control Arm-/Trailing Arm Bush	1.6, 2.0	F8-7074	
Top Strut Mounting	1.6, 1.6 CRDi, 1.8, 2.0, 2.0 CRDi	F8-7370	
Stabiliser Mounting	1.6, 1.6 CRDi, 2.0	F8-7828	
Stabiliser Mounting	1.6, 1.8, 2.0, 2.0 CRDi	F8-7828	
Belt Pulley, crankshaft	1.6 CRDi	F8-7866	

AK-735327	AK-735328	AK-735329	AK-735333	AK-735334	AK-735335	AK-735336
Ref.Nr.: 5462502000	Ref.Nr.: 5534002000	Ref.Nr.: 5534002100	Ref.Nr.: 5462627000	Ref.Nr.: 553252D000	Ref.Nr.: 546252D000	Ref.Nr.: 5462629100
F5-1055	F8-3012	F8-6366	F8-7061	F8-7063	F8-7067	F8-7070
Ref.Nr.: 37322-27010	Ref.Nr.: 503527	Ref.Nr.: 5461202000	Ref.Nr.: 54813-1H100	Ref.Nr.: 55513-2G100	Ref.Nr.: 54551-07001	Ref.Nr.: 54584-2H000
F8-7074	F8-7370	F8-7443	F8-7822	F8-7828	F8-7829	F8-7866
Ref.Nr.: 54584-17000	Ref.Nr.: 54610-29000	Ref.Nr.: 55326-07100	Ref.Nr.: 54584-1G000	Ref.Nr.: 54813-2D102	Ref.Nr.: 54812-1G100	Ref.Nr.: 23124-2A001

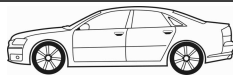
**Article Description****Article Nr.****Fitting Position**

<b>ELANTRA (XD)</b>				<b>06/2000 → 07/2006</b>	
Belt Pulley, crankshaft	2.0 CRDi		F8-7871		
<b>ELANTRA Saloon (XD)</b>				<b>06/2000 → 07/2006</b>	
Dust Cover Kit, shock absorber	1.6, 1.6 CRDi, 1.8, 2.0, 2.0 CRDi		AK-735335		
Dust Cover Kit, shock absorber	1.6, 1.6 CRDi, 1.8, 2.0, 2.0 CRDi		AK-735336		
Alternator Freewheel Clutch	2.0 CRDi		F5-1055		
Stabiliser Mounting	1.6, 1.6 CRDi, 1.8, 2.0, 2.0 CRDi		F8-7061		
Bearing Bush, stabiliser	1.6, 1.6 CRDi, 1.8, 2.0, 2.0 CRDi		F8-7063		
Control Arm-/Trailing Arm Bush	1.6 CRDi		F8-7070		
Control Arm-/Trailing Arm Bush	1.6, 2.0		F8-7074		
Top Strut Mounting	1.6, 1.6 CRDi, 1.8, 2.0, 2.0 CRDi		F8-7370		
Stabiliser Mounting	1.6, 1.6 CRDi, 2.0		F8-7828		
Stabiliser Mounting	1.6, 1.8, 2.0, 2.0 CRDi	10/2002 →	F8-7828		
Belt Pulley, crankshaft	1.6 CRDi		F8-7866		
Belt Pulley, crankshaft	2.0 CRDi		F8-7871		
<b>EQUUS / CENTENNIAL</b>				<b>10/1999 → 09/2003</b>	
Stabiliser Mounting	4.5		F8-7066		
<b>GETZ (TB)</b>				<b>09/2002 → 06/2009</b>	
Rubber Buffer, suspension	1.1, 1.3, 1.3 i, 1.4 i, 1.5 CRDi, 1.5 CRDi GLS, 1.5 i, 1.6		AK-735330		
Dust Cover Kit, shock absorber	1.1, 1.3, 1.3 i, 1.4 i, 1.5 CRDi, 1.5 i, 1.6		AK-735331		
Dust Cover Kit, shock absorber	1.5 CRDi	10/2003 →	AK-735332		
Dust Cover Kit, shock absorber	1.5 CRDi, 1.5 CRDi GLS		AK-735332		
Alternator Freewheel Clutch	1.5 CRDi, 1.5 CRDi GLS		F5-1124		
Top Strut Mounting	1.1, 1.3, 1.3 i, 1.4 i, 1.5 CRDi, 1.5 CRDi GLS, 1.5 i, 1.6		F8-7463		
Belt Pulley, crankshaft	1.5 CRDi, 1.5 CRDi GLS		F8-7866		
Stabiliser Mounting	1.1, 1.3, 1.3 i, 1.4 i, 1.6		F8-8018		
Stabiliser Mounting	1.5 CRDi, 1.5 CRDi GLS		F8-8018		
					d=19
					d=19
<b>GRANDEUR (TG)</b>				<b>04/2005 →</b>	
Stabiliser Mounting	2.2 CRDi, 3.3		F8-7066		
Belt Pulley, crankshaft	2.2 CRDi		F8-7871		
Control Arm-/Trailing Arm Bush	2.2 CRDi, 2.7, 3.3, 3.8		F8-7998		
					H=60; d=14; D=66
Stabiliser Mounting	2.2 CRDi, 3.3		F8-8020		
					d=15

<b>AK-735330</b>	<b>AK-735331</b>	<b>AK-735332</b>	<b>AK-735335</b>	<b>AK-735336</b>	<b>F5-1055</b>	<b>F5-1124</b>
Ref.Nr.: 553261C000	Ref.Nr.: 546251C000	Ref.Nr.: 546251C000	Ref.Nr.: 546252D000	Ref.Nr.: 5462629100	Ref.Nr.: 37322-27010	Ref.Nr.: 37322-27501
<b>F8-7061</b>	<b>F8-7063</b>	<b>F8-7066</b>	<b>F8-7070</b>	<b>F8-7074</b>	<b>F8-7370</b>	<b>F8-7463</b>
Ref.Nr.: 54813-1H100	Ref.Nr.: 55513-2G100	Ref.Nr.: 54813-3K100	Ref.Nr.: 54584-2H000	Ref.Nr.: 54584-17000	Ref.Nr.: 54610-29000	Ref.Nr.: 54610-22000
<b>F8-7828</b>	<b>F8-7866</b>	<b>F8-7871</b>	<b>F8-7998</b>	<b>F8-8018</b>	<b>F8-8020</b>	
Ref.Nr.: 54813-2D102	Ref.Nr.: 23124-2A001	Ref.Nr.: 2312427000	Ref.Nr.: 54584-38100	Ref.Nr.: 54812-1C000	Ref.Nr.: 55513-3K100	

Article Description			Article Nr.	Fitting Position	
<b>H-1 / STAREX</b>					<b>03/2001 → 12/2007</b>
Stabiliser Mounting	2.5 CRDi, 2.5 TD 4WD		<b>F8-7066</b>		
<b>H-1 Box</b>					<b>08/2003 → 12/2007</b>
Alternator Freewheel Clutch	2.5 CRDi		<b>F5-1054</b>		
<b>H-1 Platform/Chassis</b>					<b>12/2002 →</b>
Alternator Freewheel Clutch	2.5 CRDi		<b>F5-1054</b>		
<b>iLoad Box (TQ)</b>					<b>02/2008 →</b>
Alternator Freewheel Clutch	2.5 CRDi		<b>F5-1137</b>		
<b>i800 Bus (TQ)</b>					<b>05/2008 →</b>
Alternator Freewheel Clutch	2.5 CRDi		<b>F5-1137</b>		
<b>i10 (PA)</b>					<b>01/2008 →</b>
Stabiliser Mounting	1.1, 1.1 CRDi, 1.2		<b>F8-7060</b>		
Belt Pulley, crankshaft	1.1 CRDi		<b>F8-7866</b>		
<b>i20 (PB, PBT)</b>					<b>08/2008 →</b>
Dust Cover Kit, shock absorber	All Models		<b>AK-735331</b>		
Belt Pulley, crankshaft	1.4 CRDi, 1.6 CRDi		<b>F8-7866</b>		
<b>i30 (FD)</b>					<b>10/2007 → 11/2011</b>
Anti-Friction Bearing	1.4, 1.6, 1.6 CRDi, 2.0, 2.0 CRDi		<b>F8-3012</b>		H=20; d=66; D=100
Stabiliser Mounting	1.4, 1.6, 1.6 CRDi, 2.0, 2.0 CRDi		<b>F8-7061</b>		
Control Arm-/Trailing Arm Bush	1.4, 1.6, 1.6 CRDi, 2.0, 2.0 CRDi		<b>F8-7070</b>		
Belt Pulley, crankshaft	1.6 CRDi		<b>F8-7866</b>		
Belt Pulley, crankshaft	2.0 CRDi		<b>F8-7871</b>		
Control Arm-/Trailing Arm Bush	All Models		<b>F8-7998</b>		H=60; d=14; D=66
<b>i30 CW (FD)</b>					<b>10/2007 → 06/2012</b>
Anti-Friction Bearing	1.4, 1.6, 1.6 CRDi, 2.0, 2.0 CRDi		<b>F8-3012</b>		H=20; d=66; D=100
Stabiliser Mounting	1.6, 1.6 CRDi, 2.0, 2.0 CRDi		<b>F8-7061</b>		
Control Arm-/Trailing Arm Bush	1.6, 1.6 CRDi, 2.0, 2.0 CRDi		<b>F8-7070</b>		
Belt Pulley, crankshaft	1.6 CRDi		<b>F8-7866</b>		
Belt Pulley, crankshaft	2.0 CRDi		<b>F8-7871</b>		
Control Arm-/Trailing Arm Bush	All Models		<b>F8-7998</b>		H=60; d=14; D=66
<b>ix20 (JC)</b>					<b>11/2010 →</b>
Belt Pulley, crankshaft	1.4 CRDi, 1.6 CRDi		<b>F8-7866</b>		

<b>AK-735331</b>	<b>F5-1054</b>	<b>F5-1137</b>	<b>F8-3012</b>	<b>F8-7060</b>	<b>F8-7061</b>	<b>F8-7066</b>
Ref.Nr.: 546251C000	Ref.Nr.: 37321-4A000	Ref.Nr.: 12317790877	Ref.Nr.: 503527	Ref.Nr.: 54812-07000	Ref.Nr.: 54813-1H100	Ref.Nr.: 54813-3K100
<b>F8-7070</b>	<b>F8-7866</b>	<b>F8-7871</b>	<b>F8-7998</b>			
Ref.Nr.: 54584-2H000	Ref.Nr.: 23124-2A001	Ref.Nr.: 2312427000	Ref.Nr.: 54584-38100			

**Article Description****Article Nr.****Fitting Position**

<b>ix35 (LM, EL, ELH)</b>			<b>01/2010 →</b>		
Alternator Freewheel Clutch	2.0, 2.0 All-wheel Drive, 2.0 CRDi, 2.0 CRDi All-wheel Drive, 2.0 CRDi AWD, 2.0 GDi, 2.0 GDi 4WD		<b>F5-1138</b>		
<b>ix55</b>			<b>09/2008 →</b>		
Stabiliser Mounting	3.0 V6 CRDi		<b>F8-7066</b>		
Control Arm-/Trailing Arm Bush	3.0 V6 CRDi		<b>F8-7076</b>		
<b>LANTRA (J-1)</b>			<b>10/1990 → 11/1995</b>		
Top Strut Mounting	1.5 i.e.	12/1990 →; ☼	<b>F8-6372</b>		
Top Strut Mounting	1.6 i.e. 16V	11/1991 →; ☼	<b>F8-6372</b>		
Top Strut Mounting	1.8 i.e. 16V	06/1992 →; ☼	<b>F8-6372</b>		
<b>LANTRA Mk II (J-2)</b>			<b>11/1995 → 09/2000</b>		
Top Strut Mounting	1.5 12V, 1.6 16V, 1.6 i, 1.8 16V, 1.9 D, 2.0 16V	☼	<b>F8-7370</b>		⊕ ⊕
<b>LANTRA Mk II Estate (J-2)</b>			<b>02/1996 → 10/2000</b>		
Top Strut Mounting	1.5 12V, 1.6 16V, 1.6 i, 1.8 16V, 1.9 D, 2.0 16V	☼	<b>F8-7370</b>		⊕ ⊕
<b>MATRIX (FC)</b>			<b>06/2001 → 08/2010</b>		
Alternator Freewheel Clutch	1.5 CRDi, 1.5 CRDi VGT		<b>F5-1124</b>		
Stabiliser Mounting	1.5 CRDi, 1.5 CRDi VGT, 1.6, 1.8		<b>F8-7064</b>		H1=42; H2=46; d=22; Thick. [mm]=41
Stabiliser Mounting	1.5 CRDi, 1.5 CRDi VGT, 1.6, 1.8		<b>F8-7065</b>		d=15,8; L=44; W=30
Control Arm-/Trailing Arm Bush	1.5 CRDi, 1.5 CRDi VGT, 1.6, 1.8		<b>F8-7073</b>		⊕ ⊕ ⊕
Control Arm-/Trailing Arm Bush	1.5 CRDi, 1.5 CRDi VGT, 1.6, 1.8		<b>F8-7074</b>		⊕ ⊕ ⊕
Top Strut Mounting	1.5 CRDi, 1.6, 1.8	☼	<b>F8-7370</b>		⊕ ⊕ ⊕
Belt Pulley, crankshaft	1.5 CRDi, 1.5 CRDi VGT		<b>F8-7866</b>		
<b>PONY (X-2)</b>			<b>10/1989 → 01/1995</b>		
Dust Cover Kit, shock absorber	All Models	07/1994 →	<b>AK-735011</b>		⊕ ⊕ ⊕
Dust Cover Kit, shock absorber	All Models		<b>AK-735120</b>		⊕ ⊕ ⊕
<b>PONY / EXCEL Saloon (X-2)</b>			<b>01/1990 → 01/1995</b>		
Dust Cover Kit, shock absorber	1.3, 1.5, 1.5 i	07/1994 →	<b>AK-735011</b>		⊕ ⊕ ⊕
Dust Cover Kit, shock absorber	1.3, 1.5, 1.5 i		<b>AK-735120</b>		⊕ ⊕ ⊕
<b>PORTER Bus</b>			<b>02/2003 → 04/2004</b>		
Alternator Freewheel Clutch	2.5 CRDi		<b>F5-1054</b>		
<b>PORTER Box</b>			<b>02/2003 → 04/2004</b>		
Alternator Freewheel Clutch	2.5 CRDi		<b>F5-1054</b>		

<b>AK-735011</b>	<b>AK-735120</b>	<b>F5-1054</b>	<b>F5-1124</b>	<b>F5-1138</b>	<b>F8-6372</b>	<b>F8-7064</b>
Ref.Nr.:	Ref.Nr.:	Ref.Nr.: 37321-4A000	Ref.Nr.: 37322-27501	Ref.Nr.: 37322-2F000	Ref.Nr.: MB518798	Ref.Nr.: 54813-17100
<b>F8-7065</b>	<b>F8-7066</b>	<b>F8-7073</b>	<b>F8-7074</b>	<b>F8-7076</b>	<b>F8-7370</b>	<b>F8-7866</b>
Ref.Nr.: 55513-17000	Ref.Nr.: 54813-3K100	Ref.Nr.: 54551-25000	Ref.Nr.: 54584-17000	Ref.Nr.: 54551-2B000	Ref.Nr.: 54610-29000	Ref.Nr.: 23124-2A001

Article Description

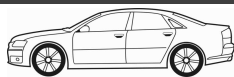

Article Nr.

Fitting Position



<b>PORTER Pickup</b>		02/2003 → 04/2004	
Alternator Freewheel Clutch	2.5 CRDi	F5-1054	
<b>PORTER Box</b>		05/2004 →	
Alternator Freewheel Clutch	2.5 CRDi	F5-1054	
<b>S COUPE (SLC)</b>		02/1990 → 05/1996	
Dust Cover Kit, shock absorber	1.5 i, 1.5 i Turbo	AK-735120	
<b>SANTA FÉ I (SM)</b>		02/2001 → 03/2006	
Dust Cover Kit, shock absorber	2.0, 2.0 CRDi, 2.0 CRDi 4x4, 2.2 CRDi, 2.4 16V, 2.4 16V 4x4, 2.7, 2.7 4x4, 2.7 V6 4x4, 3.5, 3.5 4x4	AK-735217	
Dust Cover Kit, shock absorber	2.0, 2.0 CRDi, 2.0 CRDi 4x4, 2.2 CRDi, 2.4 16V, 2.4 16V 4x4, 2.7, 2.7 4x4, 2.7 V6 4x4, 3.5, 3.5 4x4	AK-735218	
Alternator Freewheel Clutch	2.0 CRDi, 2.0 CRDi 4x4, 2.0 CRDi All-wheel Drive, 2.2 CRDi	F5-1055	
Anti-Friction Bearing	2.2 CRDi, 2.7 V6 4x4	11/2005 →	F8-6270
Control Arm-/Trailing Arm Bush	2.0 CRDi All-wheel Drive	F8-7076	
Control Arm-/Trailing Arm Bush	2.0, 2.0 CRDi, 2.0 CRDi 4x4, 2.2 CRDi, 2.4 16V, 2.4 16V 4x4, 2.7, 2.7 4x4, 2.7 V6 4x4	F8-7819	
Control Arm-/Trailing Arm Bush	2.0, 2.0 CRDi, 2.0 CRDi 4x4, 2.2 CRDi, 2.4 16V, 2.4 16V 4x4, 2.7, 2.7 4x4, 2.7 V6 4x4	F8-7820	
Control Arm-/Trailing Arm Bush	2.7	F8-7824	
Belt Pulley, crankshaft	2.0 CRDi All-wheel Drive	06/2005 →	F8-7871
Belt Pulley, crankshaft	2.0 CRDi, 2.0 CRDi 4x4, 2.0 CRDi All-wheel Drive	F8-7871	
Control Arm-/Trailing Arm Bush	2.7	F8-7998	H=60; d=14; D=66
Stabiliser Mounting	2.0, 2.0 CRDi, 2.0 CRDi 4x4, 2.0 CRDi All-wheel Drive, 2.2 CRDi, 2.4 16V, 2.4 16V 4x4, 2.7, 2.7 4x4, 2.7 V6 4x4, 3.5, 3.5 4x4	F8-8017	d=23
<b>SANTA FÉ II (CM)</b>		10/2005 → 03/2006	
Dust Cover Kit, shock absorber	2.2 CRDi 4x4	AK-735217	
Dust Cover Kit, shock absorber	2.2 CRDi 4x4	AK-735218	
Dust Cover Kit, shock absorber	2.2 CRDi, 2.2 CRDi 4x4, 2.2 CRDi GLS, 2.2 CRDi GLS 4x4, 2.7, 2.7 4x4, 2.7 V6 GLS, 2.7 V6 GLS 4x4, 3.3 Dynamic 4x4	AK-735219	
Rubber Buffer, suspension	2.2 CRDi, 2.2 CRDi 4x4, 2.2 CRDi GLS, 2.2 CRDi GLS 4x4, 2.7, 2.7 4x4, 2.7 V6 GLS, 2.7 V6 GLS 4x4, 3.3 Dynamic 4x4	AK-735220	
Alternator Freewheel Clutch	2.2 CRDi, 2.2 CRDi 4x4, 2.2 CRDi GLS, 2.2 CRDi GLS 4x4	F5-1055	
Alternator Freewheel Clutch	2.0 CRDi, 2.0 CRDi 4x4	F5-1138	
Alternator Freewheel Clutch	2.4, 2.4 4x4	F5-1139	





**Article Description****Article Nr.****Fitting Position**

<b>SANTA FÉ II (CM)</b>			<b>10/2005 → 03/2006</b>		
Stabiliser Mounting	2.2 CRDi, 2.2 CRDi 4x4, 2.2 CRDi GLS, 2.2 CRDi GLS 4x4, 2.7, 2.7 4x4, 2.7 V6 GLS, 2.7 V6 GLS 4x4		<b>F8-7066</b>		
Control Arm-/Trailing Arm Bush	2.2 CRDi, 2.2 CRDi 4x4, 2.2 CRDi GLS, 2.2 CRDi GLS 4x4, 2.7, 2.7 4x4, 2.7 V6 GLS, 2.7 V6 GLS 4x4		<b>F8-7076</b>		
Control Arm-/Trailing Arm Bush	2.2 CRDi 4x4		<b>F8-7819</b>	⊕ ⊕	
Control Arm-/Trailing Arm Bush	2.2 CRDi 4x4		<b>F8-7820</b>	⊕ ⊕	
Control Arm-/Trailing Arm Bush	2.0 CRDi, 2.0 CRDi 4x4, 2.2 CRDi, 2.2 CRDi 4x4, 2.2 CRDi GLS, 2.2 CRDi GLS 4x4, 2.4, 2.4 4x4, 2.7, 2.7 4x4, 2.7 V6 GLS, 2.7 V6 GLS 4x4		<b>F8-7824</b>	⊕ ⊕	
Belt Pulley, crankshaft	2.2 CRDi, 2.2 CRDi 4x4, 2.2 CRDi GLS, 2.2 CRDi GLS 4x4		<b>F8-7871</b>		
Control Arm-/Trailing Arm Bush	2.0 CRDi, 2.0 CRDi 4x4, 2.2 CRDi, 2.2 CRDi 4x4, 2.2 CRDi GLS, 2.2 CRDi GLS 4x4, 2.4, 2.4 4x4, 2.7, 2.7 4x4, 2.7 V6 GLS, 2.7 V6 GLS 4x4, 3.3 Dynamic 4x4		<b>F8-7998</b>	⊕ ⊕	H=60; d=14; D=66
Stabiliser Mounting	2.2 CRDi 4x4		<b>F8-8017</b>	⊕ ⊕	d=23
Stabiliser Mounting	2.0 CRDi 4x4, 2.2 CRDi, 2.2 CRDi 4x4, 2.4, 2.4 4x4, 2.7 V6 GLS, 2.7 V6 GLS 4x4		<b>F8-8123</b>	⊕ ⊕	d=15
<b>SANTA FÉ III (DM)</b>			<b>09/2012 →</b>		
Alternator Freewheel Clutch	2.0 CRDi, 2.2 CRDi, 2.2 CRDi 4WD		<b>F5-1138</b>		
Alternator Freewheel Clutch	2.4, 2.4 4WD		<b>F5-1139</b>		
<b>SONATA Mk II (Y-3)</b>			<b>05/1993 → 06/1998</b>		
Top Strut Mounting	1.8 GLS, 1.8 i, 2.0 i, 2.0 i 16V, 3.0 i V6		<b>F8-6374</b>		
<b>SONATA Mk III (EF)</b>			<b>03/1998 → 05/2005</b>		
Control Arm-/Trailing Arm Bush	2.0 16V, 2.4 16V, 2.5 V6 24V, 2.7 V6		<b>F8-7818</b>	⊕ ⊕ ↓	H=50; d=12.2; D=40
Control Arm-/Trailing Arm Bush	2.0 16V, 2.0 CRDi Dynamic, 2.2 CRDi, 2.4 16V, 2.5 V6 24V, 2.7 i V6, 2.7 V6		<b>F8-7998</b>	⊕ ⊕	H=60; d=14; D=66
Bellow, steering	2.0 16V, 2.4 16V, 2.5 V6 24V, 2.7 V6	with clamps	<b>LM-10030S</b>		d1=14; d2=48; L [mm]=158
<b>SONATA V (NF)</b>			<b>01/2005 → 12/2010</b>		
Stabiliser Mounting	2.0 CRDi, 2.0 VVTi GLS, 2.4, 3.3		<b>F8-7066</b>		
Belt Pulley, crankshaft	2.0 CRDi		<b>F8-7871</b>		
Control Arm-/Trailing Arm Bush	2.0 CRDi, 2.0 VVTi GLS, 2.4, 3.3		<b>F8-7998</b>	⊕ ⊕	H=60; d=14; D=66
Stabiliser Mounting	2.0 CRDi, 2.0 VVTi GLS, 2.4		<b>F8-8020</b>	⊕ ⊕	d=15
<b>SONATA VI (YF)</b>			<b>01/2009 →</b>		
Alternator Freewheel Clutch	2.0 i		<b>F5-1139</b>		
Alternator Freewheel Clutch	2.0, 2.4	01/2011 →	<b>F5-1139</b>		
Stabiliser Mounting	2.4		<b>F8-8020</b>	⊕ ⊕	d=15



Article Description			Article Nr.	Fitting Position	
<b>TERRACAN (HP)</b>		<b>11/2001 → 12/2006</b>			
Alternator Freewheel Clutch	2.9 CRDi, 2.9 CRDi 4WD		<b>F5-1060</b>		
Belt Pulley, crankshaft	2.9 CRDi, 2.9 CRDi 4WD		<b>F8-7865</b>		
<b>TRAJET (FO)</b>		<b>04/2001 → 07/2008</b>			
Alternator Freewheel Clutch	2.0 CRDi		<b>F5-1055</b>		
Belt Pulley, crankshaft	2.0 CRDi		<b>F8-7871</b>		
<b>TUCSON (JM)</b>		<b>08/2004 → 03/2010</b>			
Dust Cover Kit, shock absorber	2.0, 2.0 All-wheel Drive, 2.0 CRDi, 2.0 CRDi All-wheel Drive, 2.7 All-wheel Drive		<b>AK-735215</b>		
Dust Cover Kit, shock absorber	2.0, 2.0 All-wheel Drive, 2.0 CRDi, 2.0 CRDi All-wheel Drive, 2.7 All-wheel Drive		<b>AK-735216</b>		
Alternator Freewheel Clutch	2.0 CRDi, 2.0 CRDi All-wheel Drive		<b>F5-1055</b>		
Alternator Freewheel Clutch	2.0 CRDi, 2.0 CRDi All-wheel Drive		<b>F5-1138</b>		
Control Arm-/Trailing Arm Bush	2.0, 2.0 All-wheel Drive, 2.0 CRDi, 2.0 CRDi All-wheel Drive, 2.7 All-wheel Drive		<b>F8-6576</b>		
Rubber Buffer, suspension	2.0, 2.0 All-wheel Drive, 2.0 CRDi, 2.0 CRDi All-wheel Drive, 2.7 All-wheel Drive	<b>ST</b>	<b>F8-7441</b>		
Control Arm-/Trailing Arm Bush	2.0, 2.0 All-wheel Drive, 2.0 CRDi, 2.0 CRDi All-wheel Drive, 2.7 All-wheel Drive		<b>F8-7821</b>		
Belt Pulley, crankshaft	2.0 CRDi, 2.0 CRDi All-wheel Drive		<b>F8-7871</b>		
Control Arm-/Trailing Arm Bush	2.0, 2.0 All-wheel Drive, 2.0 CRDi, 2.0 CRDi All-wheel Drive, 2.7 All-wheel Drive		<b>F8-7998</b>		
<b>VISTO</b>		<b>11/1997 → 10/2000</b>			
Rubber Buffer, suspension	All Models	<b>ST</b>	<b>F8-7443</b>		
<b>XG (XG)</b>		<b>12/1998 → 12/2005</b>			
Rubber Buffer, suspension	25, 30/300	<b>ST</b>	<b>F8-7442</b>		
Control Arm-/Trailing Arm Bush	25, 30/300, 350		<b>F8-7818</b>		
Bellow, steering	All Models	with clamps	<b>LM-10030S</b>		
<b>AZERA [USA] Saloon</b>		<b>01/2006 → 12/2011</b>			
Alternator Freewheel Clutch	All Models		<b>F5-1119</b>		

<b>AK-735215</b>	<b>AK-735216</b>	<b>F5-1055</b>	<b>F5-1060</b>	<b>F5-1119</b>	<b>F5-1138</b>	<b>F8-6576</b>
Ref.Nr.: 546252E000	Ref.Nr.: 546262E000	Ref.Nr.: 37322-27010	Ref.Nr.: 37321-4X-301	Ref.Nr.: 373213C150	Ref.Nr.: 37322-2F000	Ref.Nr.: 54584-2E000
<b>F8-7441</b>	<b>F8-7442</b>	<b>F8-7443</b>	<b>F8-7818</b>	<b>F8-7821</b>	<b>F8-7865</b>	<b>F8-7871</b>
Ref.Nr.: 54626-2E000	Ref.Nr.: 55348-34910	Ref.Nr.: 55326-07100	Ref.Nr.: 54552-38000	Ref.Nr.: 54551-2E000	Ref.Nr.: 231244X011	Ref.Nr.: 2312427000
<b>F8-7998</b>	<b>LM-10030S</b>					
Ref.Nr.: 54584-38100	Ref.Nr.: 90512778					

**Article Description****Article Nr.****Fitting Position**

<b>S-TYPE (CCX)</b>		<b>01/1999 → 10/2007</b>	
Alternator Freewheel Clutch	3.0 V6	F5-1120	
Stabiliser Mounting	2.5 V6, 3.0 V6, 4.0 V8, 4.2 V8, R 4.2 V8	F8-6728	
<b>XF (_J05_, CC9)</b>		<b>06/2012 → 04/2015</b>	
Alternator Freewheel Clutch	2.0	F5-1134	
<b>XJ (N3_, X350, X358)</b>		<b>05/2003 → 03/2009</b>	
Dust Cover Kit, shock absorber	6 2.7 D, 6 3.0, 8 3.5, 8 4.2, R 4.2	AK-735357	⊕ ⊕
Dust Cover Kit, shock absorber	6 2.7 D, 6 3.0, 8 3.5, 8 4.2, R 4.2	AK-735358	⊕ ⊕
Stabiliser Mounting	6 3.0, 8 3.5, 8 4.2, R 4.2	F8-6728	
<b>XJ (NNA_, X35_, _J12_, _J24_)</b>		<b>05/2012 →</b>	
Alternator Freewheel Clutch	2.0	F5-1134	
<b>X-TYPE (CF1)</b>		<b>06/2001 → 11/2009</b>	
Dust Cover Kit, shock absorber	2.0 D, 2.0 V6, 2.2 D, 2.5 V6, 3.0 V6	AK-735354	⊕ ⊕
Dust Cover Kit, shock absorber	2.0 D, 2.0 V6, 2.2 D, 2.5 V6, 3.0 V6	AK-735355	⊕ ⊕
Alternator Freewheel Clutch	2.5 V6, 3.0 V6	F5-1120	
Control Arm-/Trailing Arm Bush	2.0 V6, 2.2 D, 2.5 V6, 3.0 V6	F8-6157	⊕ ⊕ ↓ d=12; L=69
Control Arm-/Trailing Arm Bush	2.0 V6, 2.2 D, 2.5 V6, 3.0 V6	F8-6158	⊕ ⊕ ↓ d=13; D=84; D1=75
Operating Mode: Hydraulic			
<b>X-TYPE Estate (CF1_)</b>		<b>11/2003 → 12/2009</b>	
Dust Cover Kit, shock absorber	2.0 D, 2.0 V6, 2.2 D, 2.5, 3.0	AK-735354	⊕ ⊕
Dust Cover Kit, shock absorber	2.0 D, 2.0 V6, 2.2 D, 2.5, 3.0	AK-735356	⊕ ⊕
Alternator Freewheel Clutch	2.5, 3.0	F5-1120	
Control Arm-/Trailing Arm Bush	2.0 V6, 2.2 D, 2.5, 3.0	F8-6157	⊕ ⊕ ↓ d=12; L=69
Control Arm-/Trailing Arm Bush	2.0 V6, 2.2 D, 2.5, 3.0	F8-6158	⊕ ⊕ ↓ d=13; D=84; D1=75
Operating Mode: Hydraulic			

<b>AK-735354</b>	<b>AK-735355</b>	<b>AK-735356</b>	<b>AK-735357</b>	<b>AK-735358</b>		<b>F5-1120</b>	<b>F5-1134</b>
Ref.Nr.: C2S14666	Ref.Nr.: C2S9225	Ref.Nr.: C2S30429	Ref.Nr.: C2C12560	Ref.Nr.: C2C12560		Ref.Nr.:	Ref.Nr.: 31285489
<b>F8-6157</b>	<b>F8-6158</b>	<b>F8-6728</b>					
Ref.Nr.: 1311416S1	Ref.Nr.: 1311416S2	Ref.Nr.: XR819697					

Article Description				Article Nr.	Fitting Position	
<b>CHEROKEE (KJ)</b>						<b>09/2001 → 01/2008</b>
Dust Cover Kit, shock absorber	All Models			<b>AK-735319</b>	⊕ ⊕	
Alternator Freewheel Clutch	2.5 CRD 4WD, 2.8 CRD 4WD			<b>F5-1033</b>		
<b>LIBERTY (KK)</b>						<b>01/2008 →</b>
Alternator Freewheel Clutch	2.8 CRD 4WD			<b>F5-1033</b>		
Alternator Freewheel Clutch	3.7 V6, 3.7 V6 4WD			<b>F5-1126</b>		
<b>COMMANDER (XK)</b>						<b>09/2005 → 12/2010</b>
Alternator Freewheel Clutch	3.0 CRD, 3.7 V6			<b>F5-1126</b>		
<b>GRAND CHEROKEE (ZJ)</b>						<b>09/1991 → 04/1999</b>
Dust Cover Kit, shock absorber	All Models			<b>AK-735320</b>	⊕ ⊕	
<b>GRAND CHEROKEE Mk II (WJ, WG)</b>						<b>10/2001 → 09/2005</b>
Alternator Freewheel Clutch	2.7 CRD 4x4, 2.7 CRD Laredo			<b>F5-1019</b>		
<b>GRAND CHEROKEE III (WH, WK)</b>						<b>06/2005 → 12/2010</b>
Alternator Freewheel Clutch	3.0 CRD, 3.7 V6			<b>F5-1126</b>		
<b>WRANGLER Mk II (TJ)</b>						<b>08/1996 → 12/2008</b>
Dust Cover Kit, shock absorber	2.4, 2.5, 3.8, 3.8 Rubicon Rear Wheel Drive, 4.0, 4.0 Rubicon			<b>AK-735320</b>	⊕ ⊕	
<b>WRANGLER III (JK)</b>						<b>04/2007 →</b>
Alternator Freewheel Clutch	2.8 CRD			<b>F5-1033</b>		
<b>LIBERTY [USA] Sport Utility</b>						<b>01/2002 → 12/2005</b>
Alternator Freewheel Clutch	2.4			<b>F5-1106</b>		
<b>PATRIOT [USA] Sport Utility</b>						<b>01/2007 → 12/2010</b>
Alternator Freewheel Clutch	2.4			<b>F5-1078</b>		

<b>AK-735319</b>	<b>AK-735320</b>	<b>F5-1019</b>	<b>F5-1033</b>	<b>F5-1078</b>	<b>F5-1106</b>	<b>F5-1126</b>
Ref.Nr.: 52088705AE	Ref.Nr.: 52087635	Ref.Nr.: 5117591AA	Ref.Nr.: 53013554AF	Ref.Nr.: 4891737AB	Ref.Nr.: 53013579AA	Ref.Nr.: 05175811AA

**Article Description****Article Nr.****Fitting Position**

<b>CARENS Mk II (FJ)</b>		<b>07/2002 →</b>	
Dust Cover Kit, shock absorber	All Models	AK-735369	
Dust Cover Kit, shock absorber	All Models	AK-735370	
Alternator Freewheel Clutch	2.0 CRDi	F5-1055	
<b>SEDONA I (UP)</b>		<b>08/1999 → 10/2001</b>	
Dust Cover Kit, shock absorber	2.5 V6, 2.9 TD	AK-735373	
Alternator Freewheel Clutch	2.9 TD	F5-1060	
Belt Pulley, crankshaft	2.9 TD	F8-7865	
<b>SEDONA Mk II (GQ)</b>		<b>01/1999 →</b>	
Dust Cover Kit, shock absorber	2.5 V6, 2.9 CRDi, 2.9 TD, 3.5	AK-735373	
Alternator Freewheel Clutch	2.9 CRDi, 2.9 TD	F5-1060	
Belt Pulley, crankshaft	2.9 CRDi, 2.9 TD	F8-7865	
<b>SEDONA Mk II (VQ)</b>		<b>06/2006 →</b>	
Rubber Buffer, suspension	2.2 CRDi, 2.7 V6, 2.9 CRDi	F8-7444	
Rubber Buffer, suspension	2.2 CRDi, 2.7 V6, 2.9 CRDi, 2.9 CRDi LX	F8-7445	
Belt Pulley, crankshaft	2.9 CRDi	F8-7865	
Control Arm-/Trailing Arm Bush	2.7 V6, 2.9 CRDi, 2.9 CRDi LX	F8-8025	
Control Arm-/Trailing Arm Bush	2.7 V6	F8-8026	
Control Arm-/Trailing Arm Bush	2.9 CRDi	F8-8026	
Control Arm-/Trailing Arm Bush	2.9 CRDi LX	F8-8026	
<b>CEE'D Hatchback (ED)</b>		<b>12/2006 → 12/2012</b>	
Dust Cover Kit, shock absorber	1.4, 1.6, 1.6 CRDi 115, 1.6 CRDi 90, 2.0, 2.0 CRDi 140	AK-735368	
Stabiliser Mounting	1.4, 1.6, 1.6 CRDi 115, 1.6 CRDi 90, 2.0, 2.0 CRDi 140	F8-7061	
Control Arm-/Trailing Arm Bush	1.4, 1.6, 1.6 CRDi 115, 1.6 CRDi 90, 2.0, 2.0 CRDi 140	F8-7070	
Belt Pulley, crankshaft	1.6 CRDi 115, 1.6 CRDi 90	F8-7866	
Stabiliser Mounting	1.4 CVVT	F8-8019	
<b>CEE'D SW (ED)</b>		<b>09/2007 → 12/2012</b>	
Dust Cover Kit, shock absorber	1.4, 1.6, 1.6 CRDi 115, 1.6 CRDi 90, 2.0, 2.0 CRDi 140	AK-735368	
Stabiliser Mounting	1.4, 1.6, 1.6 CRDi 115, 1.6 CRDi 90, 2.0, 2.0 CRDi 140	F8-7061	
Control Arm-/Trailing Arm Bush	1.4, 1.6, 1.6 CRDi 115, 1.6 CRDi 90, 2.0, 2.0 CRDi 140	F8-7070	
Belt Pulley, crankshaft	1.6 CRDi 115, 1.6 CRDi 90	F8-7866	
Stabiliser Mounting	1.4 CVVT	F8-8019	

<b>AK-735368</b>	<b>AK-735369</b>	<b>AK-735370</b>	<b>AK-735373</b>	<b>F5-1055</b>	<b>F5-1060</b>	<b>F8-7061</b>
Ref.Nr.: 546251H000	Ref.Nr.: 0K2FA34015	Ref.Nr.: 0K2FA28015	Ref.Nr.: KGJ2134015A	Ref.Nr.: 37322-27010	Ref.Nr.: 37321-4X-301	Ref.Nr.: 54813-1H100
<b>F8-7070</b>	<b>F8-7444</b>	<b>F8-7445</b>	<b>F8-7865</b>	<b>F8-7866</b>	<b>F8-8019</b>	<b>F8-8025</b>
Ref.Nr.: 54584-2H000	Ref.Nr.: 54626-4D000	Ref.Nr.: 55326-4D000	Ref.Nr.: 231244X011	Ref.Nr.: 23124-2A001	Ref.Nr.: 55513-1H000	Ref.Nr.: 54584-4D000
<b>F8-8026</b>						
Ref.Nr.: 54551-4D000						

Article Description

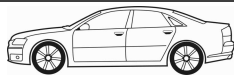

Article Nr.

Fitting Position



<b>CERATO (LD)</b>		<b>04/2004 →</b>	
Dust Cover Kit, shock absorber	1.5 CRDi, 1.6, 1.6 CRDi, 2.0, 2.0 CRDi	AK-735364	
Dust Cover Kit, shock absorber	1.5 CRDi, 1.6, 1.6 CRDi, 2.0, 2.0 CRDi	AK-735365	
Alternator Freewheel Clutch	2.0 CRDi	F5-1055	
Stabiliser Mounting	1.5 CRDi, 1.6, 1.6 CRDi, 2.0, 2.0 CRDi	F8-7061	
Belt Pulley, crankshaft	1.5 CRDi, 1.6 CRDi	F8-7866	
<b>CERATO Saloon (LD)</b>		<b>04/2004 →</b>	
Dust Cover Kit, shock absorber	1.5 CRDi, 1.6, 1.6 CRDi, 2.0, 2.0 CRDi	AK-735364	
Dust Cover Kit, shock absorber	1.5 CRDi, 1.6, 1.6 CRDi, 2.0, 2.0 CRDi	AK-735365	
Alternator Freewheel Clutch	2.0 CRDi	F5-1055	
Stabiliser Mounting	1.5 CRDi, 1.6, 1.6 CRDi, 2.0, 2.0 CRDi	F8-7061	
Belt Pulley, crankshaft	1.5 CRDi, 1.6 CRDi	F8-7866	
<b>CLARUS (K9A)</b>		<b>07/1996 →</b>	
Dust Cover Kit, shock absorber	All Models	AK-735371	
Dust Cover Kit, shock absorber	All Models	AK-735372	
<b>CLARUS Estate (GC)</b>		<b>05/1998 →</b>	
Dust Cover Kit, shock absorber	All Models	AK-735371	
Dust Cover Kit, shock absorber	All Models	AK-735372	
<b>MAGENTIS (GD)</b>		<b>05/2001 →</b>	
Bearing Bush, stabiliser	2.0, 2.5 V6	F8-7063	
Rubber Buffer, suspension	2.0, 2.5 V6	F8-7442	H=81.5
Control Arm-/Trailing Arm Bush	2.0, 2.5 V6	F8-7818	H=50; d=12.2; D=40
Bellow, steering	2.0, 2.5 V6	LM-10030S	d1=14; d2=48; L [mm]=158
<b>MAGENTIS (MG)</b>		<b>11/2005 → 12/2008</b>	
Bearing Bush, stabiliser	2.0, 2.0 CRDi, 2.7	F8-7063	
Control Arm-/Trailing Arm Bush	All Models	F8-7818	H=50; d=12.2; D=40
Control Arm-/Trailing Arm Bush	2.0, 2.0 CRDi, 2.7	F8-7821	H=55; d=12; D=38
<b>OPIRUS (GH)</b>		<b>09/2003 →</b>	
Stabiliser Mounting	3.5, 3.8 V6	F8-7066	
Rubber Buffer, suspension	3.5, 3.8 V6	F8-7442	H=81.5
Control Arm-/Trailing Arm Bush	3.5, 3.8 V6	F8-7818	H=50; d=12.2; D=40

<b>AK-735362</b>	<b>AK-735364</b>	<b>AK-735365</b>	<b>AK-735371</b>	<b>AK-735372</b>	<b>F5-1055</b>	<b>F8-7061</b>
Ref.Nr.: 5462507000	Ref.Nr.: 5462629100	Ref.Nr.: 5462629100	Ref.Nr.: 0K9A034111A	Ref.Nr.: 0K9A228111A	Ref.Nr.: 37322-27010	Ref.Nr.: 54813-1H100
<b>F8-7063</b>	<b>F8-7066</b>	<b>F8-7442</b>	<b>F8-7818</b>	<b>F8-7821</b>	<b>F8-7866</b>	<b>LM-10030S</b>
Ref.Nr.: 55513-2G100	Ref.Nr.: 54813-3K100	Ref.Nr.: 55348-34910	Ref.Nr.: 54552-38000	Ref.Nr.: 54551-2E000	Ref.Nr.: 23124-2A001	Ref.Nr.: 90512778

**Article Description****Article Nr.****Fitting Position**

<b>PICANTO (BA)</b>		<b>04/2004 →</b>	
Dust Cover Kit, shock absorber	1.0, 1.1, 1.1 CRDi	AK-735362	
Dust Cover Kit, shock absorber	1.0, 1.1, 1.1 CRDi	AK-735363	
Stabiliser Mounting	1.0, 1.1, 1.1 CRDi	F8-7060	
Control Arm-/Trailing Arm Bush	1.0, 1.1, 1.1 CRDi	F8-7067	
Rubber Buffer, suspension	All Models <b>ST</b>	F8-7443	
Belt Pulley, crankshaft	1.1 CRDi	F8-7866	
<b>PRO CEE'D (ED)</b>		<b>02/2008 → 09/2012</b>	
Stabiliser Mounting	1.4, 1.6, 1.6 CRDi 115, 1.6 CRDi 90, 2.0	F8-7061	
Bearing Bush, stabiliser	1.4, 1.6, 1.6 CRDi 115, 1.6 CRDi 90, 2.0, 2.0 CRDi 140	F8-7063	
Control Arm-/Trailing Arm Bush	1.4, 1.6, 1.6 CRDi 115, 1.6 CRDi 90, 2.0, 2.0 CRDi 140	F8-7070	
Belt Pulley, crankshaft	1.6 CRDi 115, 1.6 CRDi 90	F8-7866	
<b>RIO II (JB)</b>		<b>03/2005 →</b>	
Dust Cover Kit, shock absorber	1.4 16V, 1.5 CRDi, 1.6 CVVT	AK-735366	
Dust Cover Kit, shock absorber	1.4 16V, 1.5 CRDi, 1.6 CVVT	AK-735367	
Anti-Friction Bearing	1.4 16V, 1.5 CRDi, 1.6 CVVT	F8-3012	H=20; d=66; D=100
Control Arm-/Trailing Arm Bush	1.4 16V, 1.5 CRDi, 1.6 CVVT	F8-7067	H=54; d=12,2; D=32,5
Control Arm-/Trailing Arm Bush	1.4 16V, 1.5 CRDi, 1.6 CVVT	F8-7822	
Stabiliser Mounting	1.4 16V, 1.5 CRDi, 1.6 CVVT	F8-7829	d=24; L=45
Belt Pulley, crankshaft	1.5 CRDi	F8-7866	
<b>RIO II Saloon (JB)</b>		<b>03/2005 →</b>	
Dust Cover Kit, shock absorber	1.4 16V, 1.5 CRDi, 1.6 16V	AK-735366	
Dust Cover Kit, shock absorber	1.4 16V, 1.5 CRDi, 1.6 16V	AK-735367	
Anti-Friction Bearing	1.4 16V, 1.5 CRDi, 1.6 16V	F8-3012	H=20; d=66; D=100
Control Arm-/Trailing Arm Bush	1.4 16V, 1.5 CRDi, 1.6 16V	F8-7067	H=54; d=12,2; D=32,5
Control Arm-/Trailing Arm Bush	1.4 16V, 1.5 CRDi, 1.6 16V	F8-7822	
Stabiliser Mounting	1.4 16V, 1.5 CRDi, 1.6 16V	F8-7829	d=24; L=45
Belt Pulley, crankshaft	1.5 CRDi	F8-7866	
<b>RIO III (UB)</b>		<b>09/2011 →</b>	
Belt Pulley, crankshaft	1.1 CRDi, 1.4 CRDi	F8-7866	
<b>MENTOR (FA)</b>		<b>01/1995 → 10/1997</b>	
Dust Cover Kit, shock absorber	1.5 i, 1.8 i 16V	AK-735135	

<b>AK-735135</b>	<b>AK-735362</b>	<b>AK-735363</b>	<b>AK-735366</b>	<b>AK-735367</b>	<b>F8-3012</b>	<b>F8-7060</b>
Ref.Nr.:	Ref.Nr.: 5462507000	Ref.Nr.: 55326071	Ref.Nr.: 546251E000	Ref.Nr.: 553261G000	Ref.Nr.: 503527	Ref.Nr.: 54812-07000
<b>F8-7061</b>	<b>F8-7063</b>	<b>F8-7067</b>	<b>F8-7070</b>	<b>F8-7438</b>	<b>F8-7443</b>	<b>F8-7822</b>
Ref.Nr.: 54813-1H100	Ref.Nr.: 55513-2G100	Ref.Nr.: 54551-07001	Ref.Nr.: 54584-2H000	Ref.Nr.: 3405806	Ref.Nr.: 55326-07100	Ref.Nr.: 54584-1G000
<b>F8-7829</b>	<b>F8-7866</b>					
Ref.Nr.: 54812-1G100	Ref.Nr.: 23124-2A001					

**Article Description**

**Article Nr.**
**Fitting Position**

<b>MENTOR (FA)</b>			<b>01/1995 → 10/1997</b>		
Top Strut Mounting	All Models	🔧; with add-on material	F8-7438		
<b>MENTOR Saloon (FA)</b>			<b>09/1993 → 10/1997</b>		
Dust Cover Kit, shock absorber	1.8 i 16V		AK-735135		
Top Strut Mounting	All Models	🔧; with add-on material	F8-7438		
<b>SHUMA (FB)</b>			<b>10/1997 → 03/2001</b>		
Dust Cover Kit, shock absorber	1.5 i 16V, 1.8 i 16V		AK-735135		
<b>SHUMA Saloon (FB)</b>			<b>10/1997 → 10/2001</b>		
Dust Cover Kit, shock absorber	1.5 i 16V		AK-735135		
<b>SORENTO I (JC)</b>			<b>08/2002 →</b>		
Dust Cover Kit, shock absorber	2.4, 2.5 CRDi, 3.3 V6, 3.5 V6		AK-735374		
Alternator Freewheel Clutch	2.5 CRDi		F5-1054		
Alternator Freewheel Clutch	2.5 CRDi		F5-1137		
Stabiliser Mounting	2.4, 2.5 CRDi, 3.3 V6, 3.5 V6		F8-7066		
Rubber Buffer, suspension	2.4, 2.5 CRDi, 3.3 V6, 3.5 V6	ST	F8-7446		
Control Arm-/Trailing Arm Bush	2.4, 2.5 CRDi, 3.5 V6	12/2003 →	F8-8021		
Control Arm-/Trailing Arm Bush	2.5 CRDi, 3.3 V6		F8-8022		
Stabiliser Mounting	2.4, 2.5 CRDi, 3.3 V6, 3.5 V6		F8-8023		
Stabiliser Mounting	2.5 CRDi, 3.3 V6		F8-8024		
<b>SORENTO II (XM)</b>			<b>11/2009 →</b>		
Alternator Freewheel Clutch	2.0 CRDi, 2.0 CRDi 4WD, 2.2 CRDi, 2.2 CRDi 4WD		F5-1138		
Alternator Freewheel Clutch	2.4 CVVT, 2.4 CVVT 4WD, 2.4 GDI, 2.4 GDI 4WD		F5-1139		
Stabiliser Mounting	2.2 CRDi, 2.2 CRDi 4WD, 2.4 CVVT, 2.4 CVVT 4WD		F8-7066		
Control Arm-/Trailing Arm Bush	2.0 CRDi, 2.0 CRDi 4WD, 2.2 CRDi, 2.2 CRDi 4WD, 2.4 CVVT, 2.4 CVVT 4WD		F8-7824		
<b>SOUL (AM)</b>			<b>02/2009 →</b>		
Control Arm-/Trailing Arm Bush	1.6 CRDi 128, 1.6 CVVT		F8-7067		
Belt Pulley, crankshaft	1.6 CRDi 128		F8-7866		
<b>SPORTAGE (K00)</b>			<b>04/1994 → 08/2003</b>		
Dust Cover Kit, shock absorber	2.0, 2.0 4WD, 2.0 i 16V, 2.0 i 16V 4WD, 2.0 i 4WD, 2.0 TD 4WD, 2.2 D 4x4		AK-735375		
Dust Cover Kit, shock absorber	2.0, 2.0 4WD, 2.0 i 16V, 2.0 i 16V 4WD, 2.0 i 4WD, 2.0 TD 4WD, 2.2 D 4x4		AK-735376		

<b>AK-735135</b>	<b>AK-735215</b>	<b>AK-735374</b>	<b>AK-735375</b>	<b>AK-735376</b>	<b>F5-1054</b>	<b>F5-1137</b>
Ref.Nr.:	Ref.Nr.: 546252E000	Ref.Nr.: 546023E100	Ref.Nr.: 0K01134015A	Ref.Nr.: 0K01828111	Ref.Nr.: 37321-4A000	Ref.Nr.: 12317790877
<b>F5-1138</b>	<b>F5-1139</b>	<b>F8-7066</b>	<b>F8-7067</b>	<b>F8-7438</b>	<b>F8-7446</b>	<b>F8-7824</b>
Ref.Nr.: 37322-2F000	Ref.Nr.: 37322-2G500	Ref.Nr.: 54813-3K100	Ref.Nr.: 54551-07001	Ref.Nr.: 3405806	Ref.Nr.: 54602-3E100	Ref.Nr.: 54584-2B000
<b>F8-7866</b>	<b>F8-8021</b>	<b>F8-8022</b>	<b>F8-8023</b>	<b>F8-8024</b>		
Ref.Nr.: 23124-2A001	Ref.Nr.: 54480-3E002	Ref.Nr.: 54580-3E100	Ref.Nr.: 54813-3E000	Ref.Nr.: 55513-3E000		



**Article Description****Article Nr.****Fitting Position**

<b>SPORTAGE (JE_, KM_)</b>		<b>09/2004 →</b>	
Dust Cover Kit, shock absorber	2.0 16V 4WD, 2.0 CRDi, 2.0 CRDi 4WD, 2.0 i 16V, 2.7 V6 4WD	<b>AK-735215</b>	
Dust Cover Kit, shock absorber	2.0 16V 4WD, 2.0 CRDi, 2.0 CRDi 4WD, 2.0 i 16V, 2.7 V6 4WD	<b>AK-735216</b>	
Alternator Freewheel Clutch	2.0 CRDi, 2.0 CRDi 4WD	<b>F5-1055</b>	
Control Arm-/Trailing Arm Bush	All Models	<b>F8-6576</b>	H1=60; H2=36.7; d=14.1; D=66.4
Control Arm-/Trailing Arm Bush	2.0 CRDi 4WD	<b>F8-7072</b>	
Rubber Buffer, suspension	All Models <b>ST</b>	<b>F8-7441</b>	H=85
Control Arm-/Trailing Arm Bush	All Models	<b>F8-7821</b>	H=55; d=12; D=38
<b>SPORTAGE (SL)</b>		<b>07/2010 →</b>	
Alternator Freewheel Clutch	2.0 CRDi, 2.0 CRDi AWD	<b>F5-1138</b>	
<b>VENGA (YN)</b>		<b>02/2010 →</b>	
Control Arm-/Trailing Arm Bush	1.4 CRDi 90, 1.4 CVVT, 1.6 CRDi 128, 1.6 CVVT	<b>F8-7067</b>	H=54; d=12,2; D=32,5
Belt Pulley, crankshaft	1.4 CRDi 75, 1.4 CRDi 90, 1.6 CRDi 115, 1.6 CRDi 128	<b>F8-7866</b>	
<b>AMANTI [USA] Saloon</b>		<b>01/2004 → 12/2006</b>	
Alternator Freewheel Clutch	All Models	<b>F5-1119</b>	

<b>AK-735215</b>	<b>AK-735216</b>	<b>F5-1055</b>	<b>F5-1119</b>	<b>F5-1138</b>	<b>F8-6576</b>	<b>F8-7067</b>
Ref.Nr.: 546252E000	Ref.Nr.: 546262E000	Ref.Nr.: 37322-27010	Ref.Nr.: 373213C150	Ref.Nr.: 37322-2F000	Ref.Nr.: 54584-2E000	Ref.Nr.: 54551-07001
<b>F8-7072</b>	<b>F8-7441</b>	<b>F8-7821</b>	<b>F8-7866</b>			
Ref.Nr.: 55215-2D000	Ref.Nr.: 54626-2E000	Ref.Nr.: 54551-2E000	Ref.Nr.: 23124-2A001			





Article Description



Article Nr.

Fitting Position



<b>NIVA (2121)</b>		<b>12/1976 → 03/1995</b>	
Top Strut Mounting	1600	 ⊕ ⊕	H2=55; d=16; D1=96; D2=102
<b>SAMARA (2108, 2109, 2115)</b>		<b>01/1986 → 12/1994</b>	
Dust Cover Kit, shock absorber	1.5, 1100, 1300, 1500	<b>AK-733023</b>  ⊕ ⊕	
Dust Cover Kit, shock absorber	1100, 1300, 1500	<b>AK-735032</b>  ⊕ ⊕	
<b>SAMARA FORMA (21099)</b>		<b>05/1989 → 07/1997</b>	
Dust Cover Kit, shock absorber	1100, 1300, 1500	<b>AK-735032</b>  ⊕ ⊕	



**AK-733023**

Ref.Nr.: 191412303



**AK-735032**

Ref.Nr.:



**F8-4100**

Ref.Nr.: 344511

**Article Description****Article Nr.****Fitting Position**

<b>DEDRA (835)</b>		<b>04/1989 → 07/1999</b>	
Dust Cover Kit, shock absorber	1.6 16V, 1.6 i.e., 1.6 LE, 1.8 i.e., 1.9 TDS, 2.0 16V, 2.0 i.e., 2.0 i.e. Turbo	<b>AK-735018</b>	
Anti-Friction Bearing	1.6 i.e., 1.6 LE, 1.8 16V LE, 1.8 GT 16V, 1.8 i.e., 1.9 TDS, 2.0 16V, 2.0 HF Integrale, 2.0 i.e., 2.0 i.e. Turbo	<b>F8-3015</b>	
Stabiliser Mounting	1.6 i.e., 1.6 LE, 1.8 16V LE, 1.8 GT 16V, 1.8 i.e., 1.9 TDS, 2.0 16V, 2.0 HF Integrale, 2.0 i.e., 2.0 i.e. Turbo	<b>F8-5094</b>	
Top Strut Mounting	1.6 16V, 1.6 i.e., 1.6 LE, 1.8 16V LE, 1.8 GT 16V, 1.8 i.e., 1.9 TDS, 2.0 16V, 2.0 HF Integrale, 2.0 i.e., 2.0 i.e. Turbo	<b>F8-5513</b>	
Top Strut Mounting	1.6 16V, 1.6 i.e., 1.6 LE, 1.8 16V LE, 1.8 GT 16V, 1.8 i.e., 1.9 TDS, 2.0 16V, 2.0 HF Integrale, 2.0 i.e., 2.0 i.e. Turbo	<b>F8-5514</b>	
Top Strut Mounting	1.6 16V, 1.6 i.e., 1.6 LE, 1.8 16V LE, 1.8 GT 16V, 1.8 i.e., 1.9 TDS, 2.0 16V, 2.0 i.e., 2.0 i.e. Turbo	<b>F8-5600</b>	
Engine Mounting	1.6 i.e.	<b>F8-5641</b>	
Engine Mounting	1.6 i.e.	<b>F8-5641</b>	
Spring Cap	All Models	<b>F8-5956</b>	
Engine Mounting	1.8 i.e.	<b>F8-6914</b>	
Engine Mounting	1.6 16V	<b>F8-6936</b>	
Belt Pulley, crankshaft	1.9 TDS	<b>F8-7863</b>	
Control Arm-/Trailing Arm Bush	All Models	<b>G9-530</b>	
Control Arm-/Trailing Arm Bush	1.6 i.e., 1.6 LE, 1.8 16V LE, 1.8 GT 16V, 1.8 i.e., 1.9 TDS, 2.0 16V, 2.0 HF Integrale, 2.0 i.e., 2.0 i.e. Turbo	<b>G9-531</b>	
Control Arm-/Trailing Arm Bush	All Models	<b>G9-532</b>	
Bellow, steering	2.0 i.e.	<b>LM-10060S</b>	
<b>DEDRA SW (835)</b>		<b>07/1994 → 07/1999</b>	
Dust Cover Kit, shock absorber	All Models	<b>AK-735018</b>	
Anti-Friction Bearing	1.6, 1.8 16V LE, 1.8 GT 16V, 1.8 i.e., 1.9 TDS, 2.0 16V, 2.0 Integrale	<b>F8-3015</b>	
Stabiliser Mounting	1.6, 1.8 16V LE, 1.8 GT 16V, 1.8 i.e., 1.9 TDS, 2.0 16V, 2.0 Integrale	<b>F8-5094</b>	
Top Strut Mounting	All Models	<b>F8-5513</b>	
Top Strut Mounting	All Models	<b>F8-5514</b>	
Top Strut Mounting	All Models	<b>F8-5600</b>	
Engine Mounting	1.6	<b>F8-5641</b>	
Spring Cap	All Models	<b>F8-5956</b>	



Article Description



Article Nr.

Fitting Position



<b>DEDRA SW (835)</b>		<b>07/1994 → 07/1999</b>	
Engine Mounting	1.6 16V	<b>F8-6936</b>	⊕
Belt Pulley, crankshaft	1.9 TDS	<b>F8-7863</b>	
Control Arm-/Trailing Arm Bush	All Models	<b>G9-530</b>	⊕ ⊕ ⊕ H=50; d=20; D=41
Control Arm-/Trailing Arm Bush	1.6, 1.8 16V LE, 1.8 GT 16V, 1.8 i.e., 1.9 TDS, 2.0 16V, 2.0 Integrale	<b>G9-531</b>	⊕ ⊕ H=52; d=20; D=59
Control Arm-/Trailing Arm Bush	All Models	<b>G9-532</b>	⊕ ⊕ H=53; d=20; D=58
<b>DELTA (831AB0)</b>		<b>09/1979 → 01/1994</b>	
Dust Cover Kit, shock absorber	1.3, 1.5, 1.6 GT, 1.6 GT i.e., 1.6 HF Turbo, 1.9 Turbo DS	<b>AK-735005</b>	⊕ ⊕ ⊕
Anti-Friction Bearing	1.3, 1.5, 1.6 GT, 1.8 S4	<b>F8-3021</b>	⊕ D1/D2=innen: Ø29/Ø33; d1=29; d2=33; D=62
Top Strut Mounting	1.3, 1.5	<b>F8-5599</b>	⊕ ⊕ ⊕
Top Strut Mounting	1.6 GT i.e., 1.6 HF Turbo	<b>F8-5599</b>	⊕ ⊕ ⊕
Control Arm-/Trailing Arm Bush	2.0 16V HF Evo Integrale	<b>G9-530</b>	⊕ ⊕ ⊕ H=50; d=20; D=41
Control Arm-/Trailing Arm Bush	2.0 16V HF Evo Integrale	<b>G9-531</b>	⊕ ⊕ H=52; d=20; D=59
Control Arm-/Trailing Arm Bush	2.0 16V HF Evo Integrale	<b>G9-532</b>	⊕ ⊕ H=53; d=20; D=58
<b>DELTA Mk II (836)</b>		<b>06/1993 → 08/1999</b>	
Dust Cover Kit, shock absorber	1.6 i.e., 1.8 i.e., 2.0 16V	<b>AK-735018</b>	⊕ ⊕ ⊕
Anti-Friction Bearing	1.4 i.e., 1.6 i.e., 1.6 i.e. 16V, 1.8 i.e., 1.8 i.e. 16V, 1.8 i.e. 16V GT, 1.9 TD, 2.0 16V, 2.0 16V Turbo	<b>F8-3015</b>	⊕ ⊕ ⊕ H=48; d1=79; d2=84; D1=116; D2=128
Stabiliser Mounting	1.4 i.e., 1.6 i.e., 1.6 i.e. 16V, 1.8 i.e., 1.8 i.e. 16V, 1.8 i.e. 16V GT, 1.9 TD	<b>F8-5094</b>	⊕ d=22
Stabiliser Mounting	1.6 i.e., 1.8 i.e., 2.0 16V, 2.0 16V Turbo	<b>F8-5094</b>	⊕ d=22
Top Strut Mounting	1.4 i.e., 1.6 i.e., 1.6 i.e. 16V, 1.8 i.e., 1.8 i.e. 16V, 1.8 i.e. 16V GT, 1.9 TD, 2.0 16V, 2.0 16V Turbo	<b>F8-5513</b>	⊕ ⊕
Top Strut Mounting	1.4 i.e., 1.6 i.e., 1.6 i.e. 16V, 1.8 i.e., 1.8 i.e. 16V, 1.8 i.e. 16V GT, 1.9 TD, 2.0 16V, 2.0 16V Turbo	<b>F8-5514</b>	⊕ ⊕
Engine Mounting	1.4 i.e., 1.6 i.e.	<b>F8-5641</b>	⊕ ⊕
Spring Cap	1.4 i.e., 1.6 i.e., 1.6 i.e. 16V, 1.8 i.e., 1.8 i.e. 16V, 1.8 i.e. 16V GT, 1.9 TD, 2.0 16V, 2.0 16V Turbo	<b>F8-5956</b>	⊕ ⊕ ⊕
Engine Mounting	1.6 i.e., 1.6 i.e. 16V	<b>F8-6632</b>	⊕
Engine Mounting	1.8 i.e.	<b>F8-6914</b>	
Engine Mounting	1.6 i.e., 1.6 i.e. 16V	<b>F8-6936</b>	⊕
Belt Pulley, crankshaft	1.9 TD	<b>F8-7863</b>	
Control Arm-/Trailing Arm Bush	1.4 i.e., 1.6 i.e., 1.6 i.e. 16V, 1.8 i.e., 1.8 i.e. 16V, 1.8 i.e. 16V GT, 1.9 TD, 2.0 16V, 2.0 16V Turbo	<b>G9-530</b>	⊕ ⊕ ⊕ H=50; d=20; D=41



**Article Description****Article Nr.****Fitting Position**

<b>DELTA Mk II (836)</b>		<b>06/1993 → 08/1999</b>	
Control Arm-/Trailing Arm Bush	1.4 i.e. , 1.6 i.e. , 1.6 i.e. 16V , 1.8 i.e. , 1.8 i.e. 16V , 1.8 i.e. 16V GT , 1.9 TD , 2.0 16V , 2.0 16V Turbo	<b>G9-531</b>	⊕
Control Arm-/Trailing Arm Bush	1.4 i.e. , 1.6 i.e. , 1.6 i.e. 16V , 1.8 i.e. , 1.8 i.e. 16V , 1.8 i.e. 16V GT , 1.9 TD , 2.0 16V , 2.0 16V Turbo	<b>G9-532</b>	⊕
<b>DELTA III (844)</b>		<b>08/2008 → 08/2014</b>	
Alternator Freewheel Clutch	1.6 D Multijet, 1.9 D Multijet, 2.0 D Multijet	<b>F5-1098</b>	
Alternator Freewheel Clutch	1.6 D Multijet, 1.9 D Multijet, 2.0 D Multijet	<b>F5-1123</b>	
Alternator Freewheel Clutch	1.8	<b>F5-1147</b>	
<b>KAPPA (838A)</b>		<b>08/1994 → 10/2001</b>	
Alternator Freewheel Clutch	2.0 20V , 2.4 20V , 2.4 T.DS	<b>F5-1108</b>	
Anti-Friction Bearing	2.0 20V	<b>F8-3027</b>	⊕ ⊕
Anti-Friction Bearing	All Models	<b>F8-6264</b>	
Belt Pulley, crankshaft	2.4 JTD	Number of Ribs: 6	<b>F8-7087</b>
Control Arm-/Trailing Arm Bush	All Models	<b>G9-635</b>	⊕ ⊕
<b>KAPPA Coupe (838)</b>		<b>07/1996 → 03/2001</b>	
Anti-Friction Bearing	All Models	<b>F8-6264</b>	
Control Arm-/Trailing Arm Bush	All Models	<b>G9-635</b>	⊕ ⊕
<b>KAPPA SW (838B)</b>		<b>07/1996 → 10/2001</b>	
Alternator Freewheel Clutch	2.0 16V Turbo , 2.4 20V	<b>F5-1108</b>	
Anti-Friction Bearing	All Models	<b>F8-6264</b>	
Belt Pulley, crankshaft	2.4 JTD	Number of Ribs: 6	<b>F8-7087</b>
Control Arm-/Trailing Arm Bush	All Models	<b>G9-635</b>	⊕ ⊕
<b>LYBRA (839AX)</b>		<b>07/1999 → 10/2005</b>	
Alternator Freewheel Clutch	1.9 JTD , 2.4 JTD	<b>F5-1123</b>	
Anti-Friction Bearing	1.6, 1.6 16V , 1.8 16V , 1.9 JTD , 2.0 20V , 2.4 JTD	<b>F8-3014</b>	
Belt Pulley, crankshaft	1.9 JTD	Number of Ribs: 5; Parameter: 6PK; with screw set	<b>F8-6393</b>
Engine Mounting	2.0 20V	<b>F8-6632</b>	⊕
Engine Mounting	1.6 16V	<b>F8-6936</b>	⊕
Belt Pulley, crankshaft	2.4 JTD	09/1999 →; Number of Ribs: 6	<b>F8-7087</b>

<b>F5-1098</b>	<b>F5-1108</b>	<b>F5-1123</b>	<b>F5-1147</b>	<b>F8-3014</b>	<b>F8-3027</b>	<b>F8-6264</b>
Ref.Nr.: 77364725	Ref.Nr.: 46441617	Ref.Nr.: 9948513	Ref.Nr.: 77365271	Ref.Nr.: 503545	Ref.Nr.: 90170695	Ref.Nr.: 50700871
<b>F8-6393</b>	<b>F8-6632</b>	<b>F8-6936</b>	<b>F8-7087</b>	<b>G9-531</b>	<b>G9-532</b>	<b>G9-635</b>
Ref.Nr.: 55196301	Ref.Nr.: 60813084	Ref.Nr.: 7778563	Ref.Nr.: 55184474	Ref.Nr.: 7601068	Ref.Nr.: 7601065	Ref.Nr.: 82483400

Article Description



Article Nr.

Fitting Position



### LYBRA (839AX)

07/1999 → 10/2005

Belt Pulley, crankshaft	2.4 JTD	Number of Ribs: 6	F8-7087		Belt Pulley Ø [mm]=181; Mounting points diam.[mm]=30; W=32
Top Strut Mounting	1.6, 1.6 16V, 1.8 16V, 1.9 JTD, 2.0 20V, 2.4 JTD		F8-7436		
Bellow Set, drive shaft	2.4 JTD	with clamps	MK-810160		L=116

### LYBRA SW (839BX)

07/1999 → 10/2005

Alternator Freewheel Clutch	1.9 JTD		F5-1108		
Alternator Freewheel Clutch	1.9 JTD, 2.4 JTD		F5-1123		
Anti-Friction Bearing	All Models		F8-3014		H1=24; H2=46; d1=78; d2=84; D=128
Belt Pulley, crankshaft	1.9 JTD	Number of Ribs: 5; Parameter: 6PK; with screw set	F8-6393		D=169
Engine Mounting	2.0 20V		F8-6632		
Engine Mounting	1.6 16V		F8-6936		
Top Strut Mounting	All Models		F8-7436		
Bellow Set, drive shaft	2.4 JTD	with clamps	MK-810160		L=116

### MUSA (350)

10/2004 → 09/2012

Dust Cover Kit, shock absorber	1.3 D Multijet, 1.4, 1.9 D Multijet		AK-735377		
Dust Cover Kit, shock absorber	1.3 D Multijet, 1.4, 1.9 D Multijet		AK-735378		
Alternator Freewheel Clutch	1.3 D Multijet		F5-1041		
Alternator Freewheel Clutch	1.3 D Multijet		F5-1045		
Alternator Freewheel Clutch	1.6 D Multijet, 1.9 D Multijet		F5-1098		
Alternator Freewheel Clutch	1.9 D Multijet		F5-1123		
Anti-Friction Bearing	1.3 D Multijet, 1.9 D Multijet		F8-6266		
Top Strut Mounting	1.3 D Multijet, 1.9 D Multijet		F8-6288		
Belt Pulley, crankshaft	1.9 D Multijet	Number of Ribs: 5; Parameter: 6PK; with screw set	F8-6393		D=169
Control Arm-/Trailing Arm Bush	All Models		F8-6442		
Control Arm-/Trailing Arm Bush	1.3 D Multijet, 1.4, 1.9 D Multijet		F8-6450		
Spring Cap	1.3 D Multijet, 1.4, 1.9 D Multijet		F8-6560		
Spring Cap	1.3 D Multijet, 1.4, 1.9 D Multijet		F8-6561		
Belt Pulley, crankshaft	1.3 D Multijet	Number of Ribs: 6	F8-7086		Belt Pulley Ø [mm]=165; Mounting points diam.[mm]=35; W=30
Rubber Buffer, suspension	1.3 D Multijet, 1.4, 1.4 LPG, 1.6 D Multijet, 1.9 D Multijet		F8-7594		H=228
Mounting, manual transmission	1.4, 1.4 LPG		F8-8086		

AK-735377	AK-735378	F5-1041	F5-1045	F5-1098	F5-1108	F5-1123
Ref.Nr.: 50701077	Ref.Nr.: 51796607	Ref.Nr.: 77364723	Ref.Nr.: 77362721	Ref.Nr.: 77364725	Ref.Nr.: 46441617	Ref.Nr.: 9948513
F8-3014	F8-6266	F8-6288	F8-6393	F8-6442	F8-6450	F8-6560
Ref.Nr.: 503545	Ref.Nr.: 5035C2	Ref.Nr.: 50702206	Ref.Nr.: 55196301	Ref.Nr.: 50703231-PART	Ref.Nr.: 46551790	Ref.Nr.: 46541086
F8-6561	F8-6632	F8-6936	F8-7086	F8-7087	F8-7436	F8-7594
Ref.Nr.: 46750910	Ref.Nr.: 60813084	Ref.Nr.: 7778563	Ref.Nr.: 55200498	Ref.Nr.: 55184474	Ref.Nr.: 46544151	Ref.Nr.: 1 639 562

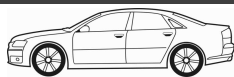
**Article Description****Article Nr.****Fitting Position**

<b>PHEDRA (179)</b>			<b>09/2002 → 11/2010</b>	
Dust Cover Kit, shock absorber	2.0, 2.0 D Multijet, 2.0 JTD, 2.2 JTD, 3.0 V6		<b>AK-735381</b>	
Alternator Freewheel Clutch	2.0 D Multijet, 2.0 JTD, 2.2 D Multijet, 2.2 JTD		<b>F5-1046</b>	
Anti-Friction Bearing	All Models		<b>F8-3014</b>	
Engine Mounting	2.0		<b>F8-5569</b>	
Top Strut Mounting	2.0, 2.0 JTD, 2.2 JTD, 3.0 V6		<b>F8-5621</b>	
Top Strut Mounting	2.0, 2.0 JTD, 2.2 JTD, 3.0 V6		<b>F8-5622</b>	
Belt Pulley, crankshaft	2.0 JTD, 2.2 JTD		<b>F8-5636</b>	
Belt Pulley, crankshaft	2.0 JTD	Orga.09521→	<b>F8-5660</b>	
Belt Pulley, crankshaft	2.2 JTD	Orga.10248→	<b>F8-5660</b>	
Engine Mounting	2.0, 2.0 JTD, 2.2 JTD		<b>F8-6236</b>	
Top Strut Mounting	2.0, 2.0 JTD, 2.2 JTD, 3.0 V6		<b>F8-6304</b>	
Control Arm-Trailing Arm Bush	2.0, 2.0 JTD, 2.2 JTD, 3.0 V6		<b>F8-6439</b>	
Engine Mounting	2.0	RFN;	<b>F8-6507</b>	
Engine Mounting	2.0 JTD, 2.2 JTD		<b>F8-6507</b>	
Top Strut Mounting	2.0, 2.0 JTD, 2.2 JTD, 3.0 V6		<b>F8-7164</b>	
Belt Pulley, crankshaft	2.0 D Multijet, 2.0 JTD		<b>F8-7861</b>	
Engine Mounting	2.0 D Multijet, 2.0 JTD, 2.2 D Multijet, 2.2 JTD		<b>F8-8149</b>	
Engine Mounting	2.0 JTD, 2.2 JTD		<b>F8-8167</b>	
<b>PRISMA (831AB0)</b>			<b>01/1983 → 02/1992</b>	
Dust Cover Kit, shock absorber	1.5, 1.6, 1.6 i.e., 1.6 i.e. Super, 1.9 Turbo Diesel		<b>AK-735005</b>	
Anti-Friction Bearing	1.3, 1.9 Turbo Diesel		<b>F8-3021</b>	
Anti-Friction Bearing	1.9 Diesel	06/1984 →	<b>F8-3021</b>	
Top Strut Mounting	1.3, 1.5, 1.9 Diesel	01/1986 →;	<b>F8-5599</b>	
Top Strut Mounting	1.5		<b>F8-5599</b>	
Top Strut Mounting	1.6, 1.6 i.e., 1.6 i.e. Super	;	<b>F8-5599</b>	
<b>THEMA (834)</b>			<b>11/1984 → 07/1994</b>	
Top Strut Mounting	2000 i.e., 2000 i.e. 16V, 2000 i.e. Turbo		<b>F8-5591</b>	
Top Strut Mounting	2000 i.e. 16V Turbo, 2000 i.e. Turbo, 2500 Turbo D, 2500 Turbo DS, 2850 V6 i.e., 3000 V6		<b>F8-5592</b>	
Top Strut Mounting	2000 i.e. Turbo	09/1988 →;	<b>F8-5592</b>	
Top Strut Mounting	All Models		<b>F8-5603</b>	

<b>AK-735005</b>	<b>AK-735381</b>	<b>F5-1046</b>	<b>F8-3014</b>	<b>F8-3021</b>	<b>F8-5569</b>	<b>F8-5591</b>
Ref.Nr.:	Ref.Nr.: 1400257380	Ref.Nr.: 30667687	Ref.Nr.: 503545	Ref.Nr.: 82382210	Ref.Nr.: 9604338880	Ref.Nr.: 82398815
<b>F8-5592</b>	<b>F8-5599</b>	<b>F8-5603</b>	<b>F8-5621</b>	<b>F8-5622</b>	<b>F8-5636</b>	<b>F8-5640</b>
Ref.Nr.: 82398818	Ref.Nr.: 82403819	Ref.Nr.: 82430666	Ref.Nr.: 1311931080	Ref.Nr.: 503868	Ref.Nr.: 0515P2	Ref.Nr.: 82388242
<b>F8-5660</b>	<b>F8-6236</b>	<b>F8-6304</b>	<b>F8-6439</b>	<b>F8-6507</b>	<b>F8-7164</b>	<b>F8-7861</b>
Ref.Nr.: 0515R9	Ref.Nr.: 1809.21	Ref.Nr.: 1311930080	Ref.Nr.: 1312317080	Ref.Nr.: 1827.16	Ref.Nr.: 503555	Ref.Nr.: 0515 Q8

Article Description



Article Nr.

Fitting Position



<b>THEMA (834)</b>				<b>11/1984 → 07/1994</b>	
Mounting, axle beam	2000 i.e., 2000 i.e., 2000 i.e. 16V, 2000 i.e. 16V Turbo, 2000 i.e. Turbo, 2000 i.e. Turbo, 2500 Turbo D, 2500 Turbo DS, 2850 V6 i.e.		<b>F8-5640</b>		
Bellow, steering	2000 16V, 2000 16V Turbo, 2000 i.e., 2000 i.e., 2000 i.e. 16V, 2000 i.e. 16V Turbo, 2000 i.e. Turbo, 2000 i.e. Turbo, 2500 Turbo D, 2500 Turbo DS, 3000 V6	with clamps;	<b>LM-10060S</b>		d1=10; d2=48; L [mm]=170
<b>THEMA SW (834)</b>				<b>03/1987 → 07/1994</b>	
Top Strut Mounting	2000 i.e. 16V		<b>F8-5591</b>		
Top Strut Mounting	2000 16V, 2000 i.e. 16V Turbo, 2000 Turbo, 3000 V6		<b>F8-5592</b>		
Top Strut Mounting	All Models		<b>F8-5603</b>		H=50; d=14; D=145
Mounting, axle beam	2000 16V, 2000 i.e. 16V, 2000 i.e. 16V Turbo, 2500 Turbo DS		<b>F8-5640</b>		
Bellow, steering	All Models	with clamps;	<b>LM-10060S</b>		d1=10; d2=48; L [mm]=170
<b>THESIS (841AX)</b>				<b>07/2002 → 07/2009</b>	
Dust Cover Kit, shock absorber	2.0 Turbo, 2.4, 2.4 D Multijet, 2.4 JTD, 3.0 V6, 3.2 V6		<b>AK-735380</b>		
Alternator Freewheel Clutch	2.0 Turbo, 2.4, 2.4 D Multijet, 2.4 JTD		<b>F5-1123</b>		
Bellow, steering	2.0 Turbo, 2.4, 2.4 D Multijet, 2.4 JTD, 3.0 V6, 3.2 V6	with clamps	<b>LM-10038S</b>		d1=12; d2=61; L [mm]=210
<b>Y (840A)</b>				<b>11/1995 → 09/2003</b>	
Engine Mounting	1.1	04/1997 →;	<b>F8-5415</b>		
Engine Mounting	1.2, 1.2 16V		<b>F8-5415</b>		
Top Strut Mounting	1.1, 1.2, 1.2 16V, 1.4 12V		<b>F8-5858</b>		
Mounting, axle beam	All Models		<b>F8-5864</b>		H=29; d=16; D=72
Bearing Bush, stabiliser	All Models		<b>F8-6731</b>		
Holder, engine mounting	1.1, 1.2, 1.2 16V		<b>F8-7012</b>		
Holder, engine mounting	1.1, 1.2 16V, 1.4 12V		<b>F8-7013</b>		
Holder, engine mounting	1.2	188 A4.000, 840 A3.000;	<b>F8-7013</b>		
Holder, engine mounting	1.2 16V		<b>F8-7013</b>		
Belt Pulley, crankshaft	1.2	188 A4.000; Engine →1731472;	<b>F8-7648</b>		
Belt Pulley, crankshaft	1.2	840 A3.000; ,	<b>F8-7648</b>		
Belt Pulley, crankshaft	1.2 16V	Engine →0804022;	<b>F8-7648</b>		
Belt Pulley, crankshaft	1.2 16V	,	<b>F8-7648</b>		
Control Arm-/Trailing Arm Bush	1.1	04/1997 →	<b>G9-533</b>		H=55; D1=32; D2=38
Control Arm-/Trailing Arm Bush	1.2, 1.2 16V, 1.4 12V		<b>G9-533</b>		H=55; D1=32; D2=38
Control Arm-/Trailing Arm Bush	All Models		<b>G9-584</b>		

<b>AK-735380</b>	<b>F5-1123</b>	<b>F8-5415</b>	<b>F8-5591</b>	<b>F8-5592</b>	<b>F8-5603</b>	<b>F8-5640</b>
Ref.Nr.: 60674507	Ref.Nr.: 9948513	Ref.Nr.: 7784313	Ref.Nr.: 82398815	Ref.Nr.: 82398818	Ref.Nr.: 82430666	Ref.Nr.: 82388242
<b>F8-5858</b>	<b>F8-5864</b>	<b>F8-6731</b>	<b>F8-7012</b>	<b>F8-7013</b>	<b>F8-7648</b>	<b>G9-533</b>
Ref.Nr.: 07775940	Ref.Nr.: 46476755	Ref.Nr.: 7750990	Ref.Nr.: 46439876	Ref.Nr.: 7737417	Ref.Nr.: 7778028	Ref.Nr.: 7673581
<b>G9-584</b>	<b>G9-612</b>	<b>LM-10038S</b>	<b>LM-10060S</b>			
Ref.Nr.: 7775344R	Ref.Nr.: 7775343	Ref.Nr.: 9947921	Ref.Nr.: 9938779			



**Article Description****Article Nr.****Fitting Position**

<b>Y (840A)</b>				<b>11/1995 → 09/2003</b>	
Control Arm-/Trailing Arm Bush	All Models		<b>G9-612</b>		
<b>Y10 (156)</b>				<b>03/1985 → 12/1995</b>	
Dust Cover Kit, shock absorber	1.0 Fire, 1.0 Fire 4WD, 1.0 Turbo, 1.1 i.e. Fire, 1.1 i.e. Fire 4WD, 1.3 i.e. Fire		<b>AK-735005</b>		
Dust Cover Kit, shock absorber	All Models		<b>AK-735097</b>		
Anti-Friction Bearing	1.0 Fire, 1.0 Fire 4WD, 1.0 Turbo, 1.1 Avenue, 1.1 Avenue 4WD, 1.1 i.e., 1.1 i.e. 4WD, 1.1 i.e. Fire, 1.1 i.e. Fire 4WD, 1.3 i.e. Fire		<b>F8-3017</b>		d=50; D=70
Top Strut Mounting	1.0 Fire, 1.0 Fire 4WD, 1.0 Turbo, 1.1 Avenue, 1.1 Avenue 4WD, 1.1 i.e., 1.1 i.e. 4WD, 1.1 i.e. Fire, 1.1 i.e. Fire 4WD, 1.3 i.e. Fire		<b>F8-5618</b>		
Engine Mounting	1.0 Fire	01/1989 →;	<b>F8-6887</b>		
Engine Mounting	1.0 Fire, 1.1 Avenue, 1.1 i.e., 1.1 i.e. Fire, 1.3 i.e. Fire		<b>F8-6887</b>		
Engine Mounting	1.0 Fire	01/1989 →	<b>F8-6893</b>		
Engine Mounting	1.0 Fire, 1.0 Fire 4WD, 1.1 Avenue, 1.1 Avenue 4WD, 1.1 i.e., 1.1 i.e. 4WD, 1.1 i.e. Fire, 1.3 i.e. Fire		<b>F8-6893</b>		
Engine Mounting	1.0 Fire	01/1989 →	<b>F8-6911</b>		
Engine Mounting	1.0 Fire, 1.0 Turbo, 1.1 Avenue, 1.1 i.e., 1.1 i.e. Fire, 1.3 i.e. Fire		<b>F8-6911</b>		
Engine Mounting	1.0 Fire, 1.0 Turbo, 1.1 Avenue, 1.1 i.e., 1.1 i.e. Fire, 1.3 i.e. Fire		<b>F8-6911</b>		
Engine Mounting	1.0 Fire 4WD, 1.1 Avenue 4WD, 1.1 i.e. 4WD		<b>F8-6955</b>		
Engine Mounting	1.1 Avenue		<b>F8-6956</b>		
Engine Mounting	1.1 i.e. Fire	01/1992 →	<b>F8-6956</b>		
Engine Mounting	1.3 i.e. Fire	01/1992 →;  146A5.046	<b>F8-6956</b>		
Control Arm-/Trailing Arm Bush	All Models		<b>G9-506</b>		
					H=37; d=9,2; D1=25; D2=36
<b>YPSILON (843)</b>				<b>10/2003 → 12/2011</b>	
Alternator Freewheel Clutch	1.3 D Multijet		<b>F5-1041</b>		
Alternator Freewheel Clutch	1.3 D Multijet, 1.3 JTD		<b>F5-1045</b>		
Control Arm-/Trailing Arm Bush	All Models		<b>F8-6442</b>		
Spring Cap	1.2, 1.3 JTD, 1.4 16V		<b>F8-6560</b>		
Spring Cap	1.2, 1.3 JTD, 1.4 16V		<b>F8-6561</b>		
Belt Pulley, crankshaft	1.3 D Multijet	12/2007 →; Number of Ribs: 6	<b>F8-7086</b>		Belt Pulley Ø [mm]=165; Mounting points diam.[mm]=35; W=30

<b>AK-735005</b>	<b>AK-735097</b>	<b>F5-1041</b>	<b>F5-1045</b>	<b>F8-3017</b>	<b>F8-5618</b>	<b>F8-6442</b>
Ref.Nr.:	Ref.Nr.:	Ref.Nr.: 77364723	Ref.Nr.: 77362721	Ref.Nr.: 4400895	Ref.Nr.: 7765188	Ref.Nr.: 50703231-PART
<b>F8-6560</b>	<b>F8-6561</b>	<b>F8-6887</b>	<b>F8-6893</b>	<b>F8-6911</b>	<b>F8-6955</b>	<b>F8-6956</b>
Ref.Nr.: 46541086	Ref.Nr.: 46750910	Ref.Nr.: 7667850	Ref.Nr.: 7613889	Ref.Nr.: 7544643	Ref.Nr.: 7550361	Ref.Nr.: 7720288
<b>F8-7086</b>	<b>G9-506</b>	<b>G9-612</b>				
Ref.Nr.: 55200498	Ref.Nr.: 0004288726	Ref.Nr.: 7775343				

**Article Description**

**Article Nr.**
**Fitting Position**

<b>YPSILON (843)</b>			<b>10/2003 → 12/2011</b>		
Belt Pulley, crankshaft	1.3 D Multijet, 1.3 JTD	Number of Ribs: 6	<b>F8-7086</b>		Belt Pulley Ø [mm]=165; Mounting points diam.[mm]=35; W=30
Rubber Buffer, suspension	1.2, 1.3 D Multijet, 1.3 JTD, 1.4, 1.4 16V		<b>F8-7594</b>		H=228
Mounting, manual transmission	1.2, 1.4, 1.4 16V		<b>F8-8086</b>		
Control Arm-/Trailing Arm Bush	1.2, 1.3 D Multijet, 1.3 JTD, 1.4, 1.4 16V		<b>G9-584</b>		
Control Arm-/Trailing Arm Bush	1.2, 1.3 D Multijet, 1.3 JTD, 1.4, 1.4 16V		<b>G9-612</b>		
<b>YPSILON (312, 846)</b>			<b>05/2011 →</b>		
Alternator Freewheel Clutch	1.3 Multijet		<b>F5-1041</b>		
Top Strut Mounting	0.9 Twinair, 1.2, 1.2 Bifuel, 1.3 Multijet		<b>F8-7421</b>		
Rubber Buffer, suspension	0.9 Twinair, 1.2, 1.2 Bifuel, 1.3 Multijet		<b>F8-7594</b>		H=228
<b>ZETA (220)</b>			<b>05/1995 → 09/2002</b>		
Dust Cover Kit, shock absorber	2.0 16V , 2.0 JTD , 2.0 Turbo , 2.1 TD		<b>AK-735091</b>		
Anti-Friction Bearing	All Models		<b>F8-3014</b>		H1=24; H2=46; d1=78; d2=84; D=128
Engine Mounting	2.1 TD		<b>F8-5026</b>		d=10; D=70; Thick. [mm]=40, 53
Stabiliser Mounting	2.0 Turbo , 2.1 TD		<b>F8-5092</b>		d=24
Top Strut Mounting	2.0 16V , 2.0 JTD , 2.0 Turbo , 2.1 TD		<b>F8-5621</b>		
Top Strut Mounting	2.0 16V , 2.0 JTD , 2.0 Turbo , 2.1 TD		<b>F8-5622</b>		
Belt Pulley, crankshaft	2.0 JTD		<b>F8-5636</b>		d=30
Mounting, axle beam	2.0 16V , 2.0 JTD , 2.0 Turbo , 2.1 TD		<b>F8-5871</b>		H1=60; H2=48; d=12; D=46
Rubber Buffer, suspension	2.0 Turbo , 2.1 TD		<b>F8-5936</b>		
Control Arm-/Trailing Arm Bush	All Models		<b>F8-6153</b>		
Control Arm-/Trailing Arm Bush	All Models		<b>F8-6154</b>		
Control Arm-/Trailing Arm Bush	All Models		<b>F8-6155</b>		
Engine Mounting	All Models		<b>F8-6236</b>		H1=53; H2=40; d=10; D=70
Top Strut Mounting	All Models		<b>F8-6304</b>		
Control Arm-/Trailing Arm Bush	2.0 16V , 2.0 JTD , 2.0 Turbo , 2.1 TD		<b>F8-6439</b>		H=50; d=22.85; Inner Thread 1=M12 x 1,25 RHT F; Inner Thread 2=M12 x 1,25 RHT F; L=82
Engine Mounting	2.0 16V		<b>F8-6507</b>		
Engine Mounting	2.0 16V , 2.0 JTD, 2.0 Turbo , 2.1 TD		<b>F8-6507</b>		
Engine Mounting	2.0 JTD	05/2000 →	<b>F8-6507</b>		

<b>AK-735091</b>	<b>F5-1041</b>	<b>F8-3014</b>	<b>F8-5026</b>	<b>F8-5092</b>	<b>F8-5621</b>	<b>F8-5622</b>
Ref.Nr.: 503339	Ref.Nr.: 77364723	Ref.Nr.: 503545	Ref.Nr.: 9606121080	Ref.Nr.: 1305782080	Ref.Nr.: 1311931080	Ref.Nr.: 503868
<b>F8-5636</b>	<b>F8-5871</b>	<b>F8-5936</b>	<b>F8-6153</b>	<b>F8-6154</b>	<b>F8-6155</b>	<b>F8-6236</b>
Ref.Nr.: 0515P2	Ref.Nr.: 515261	Ref.Nr.: 5033.39	Ref.Nr.: 3520.G9S1	Ref.Nr.: 3521.C9S	Ref.Nr.: 1316735080S	Ref.Nr.: 1809.21
<b>F8-6304</b>	<b>F8-6439</b>	<b>F8-6507</b>	<b>F8-7086</b>	<b>F8-7164</b>	<b>F8-7421</b>	<b>F8-7594</b>
Ref.Nr.: 1311930080	Ref.Nr.: 1312317080	Ref.Nr.: 1827.16	Ref.Nr.: 55200498	Ref.Nr.: 503555	Ref.Nr.: 51813225	Ref.Nr.: 1 639 562



Article Description

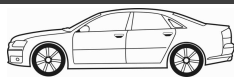

Article Nr.

Fitting Position



### ZETA (220)

05/1995 → 09/2002

Top Strut Mounting	2.0 16V , 2.0 JTD , 2.0 Turbo , 2.1 TD		<b>F8-7164</b>		
Engine Mounting	2.0 JTD		<b>F8-8149</b>		
Engine Mounting	2.0 JTD		<b>F8-8167</b>		
Bellow, steering	All Models	with clamps	<b>LM-10022S</b>		d1=13; d2=62; L [mm]=210

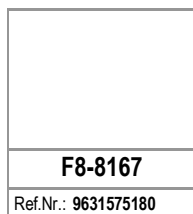
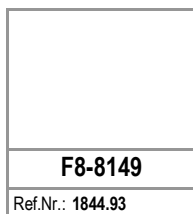

Article Description

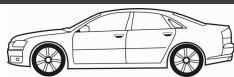

Article Nr.

Fitting Position



<b>DISCOVERY III (TAA, LA_)</b>		07/2004 → 09/2009	
Rod Assembly	2.7 TD, 4.4	F8-6421	⊕ ⊕
Stabiliser Mounting	All Models	F8-8096	⊕ ⊕
Stabiliser Mounting	All Models	F8-8097	⊕ ⊕ ⊕
<b>DISCOVERY IV (LA)</b>		09/2009 →	
Stabiliser Mounting	3.0 4x4, 3.0 SDV6, 3.0 TD	F8-8095	⊕ ⊕ ⊕ d=28,5
<b>FREELANDER (LN)</b>		02/1998 → 10/2006	
Dust Cover Kit, shock absorber	1.8 i 16V, 2.0 DI	AK-735382	⊕ ⊕ ⊕
Dust Cover Kit, shock absorber	All Models	AK-735383	⊕ ⊕ ⊕
Dust Cover Kit, shock absorber	1.8 16V, 2.0 Td4, 2.5 V6	AK-735384	⊕ ⊕ ⊕
<b>RANGE ROVER Mk III (LM)</b>		03/2002 → 08/2012	
Dust Cover Kit, shock absorber	3.0 TD 6, 3.6 TD 8, 4.2, 4.4	AK-735385	⊕ ⊕ ⊕
Engine Mounting	4.2, 4.4	F8-6972	⊕
Engine Mounting	4.2, 4.4	F8-6973	⊕
<b>RANGE ROVER SPORT (LS)</b>		02/2005 → 03/2013	
Rod Assembly	2.7 TDVM, 3.6 TD 8, 4.2, 4.4	F8-6421	⊕ ⊕ ⊕
Stabiliser Mounting	2.7 TDVM, 3.0 TD, 3.0 TD V6, 3.6 TD 8, 4.2, 4.4, 5.0, 5.0 V8	F8-8098	⊕ ⊕ ⊕ d=30
Stabiliser Mounting	2.7 TDVM, 3.0 TD, 3.0 TD V6, 3.6 TD 8, 4.2, 4.4, 5.0, 5.0 V8	F8-8099	⊕ ⊕ ⊕ d=34
Stabiliser Mounting	2.7 TDVM, 3.0 TD, 3.0 TD V6, 3.6 TD 8, 4.2, 4.4, 5.0, 5.0 V8	F8-8100	⊕ ⊕ ⊕ d=23

<b>AK-735382</b>	<b>AK-735383</b>	<b>AK-735384</b>	<b>AK-735385</b>	<b>F8-6421</b>	<b>F8-6972</b>	<b>F8-6973</b>
Ref.Nr.: EAP7162L	Ref.Nr.: ANR6124	Ref.Nr.: RNE100143	Ref.Nr.: RPC000030	Ref.Nr.: RGD500083 PA	Ref.Nr.: KKB000270	Ref.Nr.: KKB000280
<b>F8-8095</b>	<b>F8-8096</b>	<b>F8-8097</b>	<b>F8-8098</b>	<b>F8-8099</b>	<b>F8-8100</b>	
Ref.Nr.: LR018346	Ref.Nr.: LR015336	Ref.Nr.: LR015339	Ref.Nr.: LR015344	Ref.Nr.: RVU000021	Ref.Nr.: RGX500070	

**Article Description****Article Nr.****Fitting Position**

<b>2 (DY)</b>				<b>04/2003 → 06/2007</b>	
Dust Cover Kit, shock absorber	1.25, 1.3 L, 1.4, 1.4 CD, 1.5, 1.6	<b>ST</b>	<b>AK-735095</b>		
Alternator Freewheel Clutch	1.4 CD		<b>F5-1052</b>		
Anti-Friction Bearing	1.25, 1.4, 1.4 CD, 1.6		<b>F8-6317</b>		
Top Strut Mounting	1.25, 1.3 L, 1.4, 1.4 CD, 1.5, 1.6		<b>F8-6358</b>		
Belt Pulley, crankshaft	1.4 CD	Number of Ribs: 6	<b>F8-7082</b>		Belt Pulley Ø [mm]=152; Mounting points diam.[mm]=30; W=34
Top Strut Mounting	1.25, 1.3 L, 1.4, 1.4 CD, 1.5, 1.6		<b>F8-7431</b>		
Engine Mounting	1.25, 1.3 L, 1.4, 1.4 CD, 1.6		<b>F8-8139</b>		
Repair Kit, suspension strut	1.25, 1.3 L, 1.4, 1.4 CD, 1.6		<b>F8-8213</b>		
<b>2 (DE)</b>				<b>10/2007 → 06/2015</b>	
Dust Cover Kit, shock absorber	1.3, 1.4 MZR-CD, 1.5, 1.6 MZ-CD	<b>ST</b>	<b>AK-735095</b>		
Dust Cover Kit, shock absorber	1.3, 1.3 MZR, 1.4 MZR-CD, 1.5, 1.5 MZR, 1.6 MZ-CD	<b>ST</b>	<b>AK-735435</b>		
Belt Pulley, crankshaft	1.4 MZR-CD	Number of Ribs: 6	<b>F8-7082</b>		Belt Pulley Ø [mm]=152; Mounting points diam.[mm]=30; W=34
Anti-Friction Bearing	1.3, 1.3 MZR, 1.4 MZR-CD, 1.5, 1.5 MZR, 1.6 MZ-CD		<b>F8-7433</b>		
Top Strut Mounting	1.3, 1.4 MZR-CD, 1.5, 1.6 MZ-CD		<b>F8-7434</b>		
					H=48; d=8
<b>3 (BK)</b>				<b>10/2003 → 06/2009</b>	
Dust Cover Kit, shock absorber	1.4, 1.6, 1.6 DI Turbo, 2.0		<b>AK-735095</b>		
Dust Cover Kit, shock absorber	1.4, 1.6, 1.6 DI Turbo, 2.0, 2.0 MZR-CD, 2.3 DiSi Turbo MPS, 2.3 MPS, 2.3 MZR, 2.3 MZR Sport		<b>AK-735388</b>		
Alternator Freewheel Clutch	1.6		<b>F5-1082</b>		
Alternator Freewheel Clutch	2.0 MZR-CD		<b>F5-1097</b>		
Alternator Freewheel Clutch	2.3 DiSi Turbo MPS, 2.3 MPS, 2.3 MZR Sport		<b>F5-1142</b>		
Top Strut Mounting	1.4, 1.6, 1.6 DI Turbo, 2.0 MZR-CD, 2.3 DiSi Turbo MPS, 2.3 MPS, 2.3 MZR, 2.3 MZR Sport		<b>F8-6210</b>		
Anti-Friction Bearing	1.4, 1.6, 1.6 DI Turbo, 2.0, 2.0 MZR-CD, 2.3 DiSi Turbo MPS, 2.3 MPS, 2.3 MZR, 2.3 MZR Sport		<b>F8-6268</b>		
Top Strut Mounting	1.4, 1.6, 1.6 DI Turbo, 2.0		<b>F8-6357</b>		
Mounting, axle beam	1.4, 1.6, 1.6 DI Turbo, 2.0, 2.0 MZR-CD, 2.3 DiSi Turbo MPS, 2.3 MPS, 2.3 MZR, 2.3 MZR Sport		<b>F8-6638</b>		
					D=60
Belt Pulley, crankshaft	1.6 DI Turbo	Number of Ribs: 6	<b>F8-7082</b>		Belt Pulley Ø [mm]=152; Mounting points diam.[mm]=30; W=34
Protective Cap/Bellow, shock absorber	1.4, 1.6, 1.6 DI Turbo, 2.0, 2.0 MZR-CD, 2.3 DiSi Turbo MPS, 2.3 MPS, 2.3 MZR, 2.3 MZR Sport		<b>F8-7838</b>		
					H=250
Control Arm-Trailing Arm Bush	1.4, 1.6, 1.6 DI Turbo, 2.0, 2.0 MZR-CD, 2.3 DiSi Turbo MPS, 2.3 MPS		<b>F8-8078</b>		

<b>AK-735095</b>	<b>AK-735388</b>	<b>AK-735435</b>	<b>F5-1052</b>	<b>F5-1082</b>	<b>F5-1097</b>	<b>F5-1142</b>
Ref.Nr.: 1J0512131B	Ref.Nr.: BP4K34111C	Ref.Nr.: 1514543	Ref.Nr.:	Ref.Nr.: LW18-18-W11	Ref.Nr.: A6 28X9 2071	Ref.Nr.: L3M6-18-W11
<b>F8-6210</b>	<b>F8-6268</b>	<b>F8-6317</b>	<b>F8-6357</b>	<b>F8-6358</b>	<b>F8-6638</b>	<b>F8-7082</b>
Ref.Nr.: 3M513K155DC	Ref.Nr.: 30639948	Ref.Nr.: 1146152	Ref.Nr.: 30714395	Ref.Nr.: 1330706	Ref.Nr.: C2Y6-28-460	Ref.Nr.: 0515.R0
<b>F8-7431</b>	<b>F8-7433</b>	<b>F8-7434</b>	<b>F8-7838</b>	<b>F8-8078</b>	<b>F8-8139</b>	<b>F8-8213</b>
Ref.Nr.: 1469224	Ref.Nr.: 1514857	Ref.Nr.: 1535299	Ref.Nr.: 1305329	Ref.Nr.: 3M5J-3A262-BP	Ref.Nr.: 1695146	Ref.Nr.: 1151926

**Article Description**

**Article Nr.**
**Fitting Position**

<b>3 (BK)</b>			<b>10/2003 → 06/2009</b>	
Control Arm-/Trailing Arm Bush	2.3 MZR Sport	L3YS, L3YT	<b>F8-8078</b>	
Engine Mounting	1.4, 1.6		<b>F8-8140</b>	
<b>3 Saloon (BK)</b>			<b>06/2000 → 06/2009</b>	
Dust Cover Kit, shock absorber	1.6, 1.6 DI Turbo, 2.0, 2.0 MZR-CD, 2.3		<b>AK-735095</b>	
Dust Cover Kit, shock absorber	1.6, 1.6 DI Turbo, 2.0, 2.0 MZR-CD, 2.3		<b>AK-735388</b>	
Alternator Freewheel Clutch	1.6		<b>F5-1082</b>	
Alternator Freewheel Clutch	2.0 MZR-CD		<b>F5-1097</b>	
Alternator Freewheel Clutch	2.3		<b>F5-1142</b>	
Top Strut Mounting	1.6, 1.6 DI Turbo, 2.0, 2.0 MZR-CD, 2.3		<b>F8-6210</b>	
Anti-Friction Bearing	1.6, 1.6 DI Turbo, 2.0, 2.0 MZR-CD, 2.3		<b>F8-6268</b>	
Top Strut Mounting	1.6, 1.6 DI Turbo, 2.0		<b>F8-6357</b>	
Mounting, axle beam	1.6, 1.6 DI Turbo, 2.0, 2.0 MZR-CD, 2.3		<b>F8-6638</b>	D=60
Belt Pulley, crankshaft	1.6 DI Turbo	Number of Ribs: 6	<b>F8-7082</b>	Belt Pulley Ø [mm]=152; Mounting points diam.[mm]=30; W=34
Protective Cap/Bellow, shock absorber	1.6, 1.6 DI Turbo, 2.0, 2.0 MZR-CD, 2.3		<b>F8-7838</b>	H=250
Control Arm-/Trailing Arm Bush	1.6, 1.6 DI Turbo, 2.0, 2.0 MZR-CD, 2.3		<b>F8-8078</b>	
Engine Mounting	1.6		<b>F8-8140</b>	
<b>3 (BL)</b>			<b>12/2008 →</b>	
Alternator Freewheel Clutch	1.6 MZR		<b>F5-1082</b>	
Alternator Freewheel Clutch	2.2 MZR-CD		<b>F5-1097</b>	
Alternator Freewheel Clutch	2.3 MPS Turbo		<b>F5-1142</b>	
Anti-Friction Bearing	1.6 MZR, 1.6 MZR CD, 1.6 MZR-CD, 2.0 MZR, 2.0 MZR DISI, 2.2 MZR-CD		<b>F8-6268</b>	
Protective Cap/Bellow, shock absorber	1.6 MZR, 1.6 MZR CD, 1.6 MZR-CD, 2.0 MZR, 2.0 MZR DISI, 2.2 MZR-CD, 2.3 MPS Turbo		<b>F8-7838</b>	H=250
<b>3 Saloon (BL)</b>			<b>12/2008 →</b>	
Alternator Freewheel Clutch	1.6 MZR		<b>F5-1082</b>	
Alternator Freewheel Clutch	2.2 MZR-CD		<b>F5-1097</b>	
Anti-Friction Bearing	1.6 MZR, 1.6 MZR CD, 2.0 MZR, 2.0 MZR DISI, 2.2 MZR-CD		<b>F8-6268</b>	
Protective Cap/Bellow, shock absorber	1.6 MZR, 1.6 MZR CD, 2.0 MZR, 2.0 MZR DISI, 2.2 MZR-CD		<b>F8-7838</b>	H=250
<b>5 (CR19)</b>			<b>02/2005 →</b>	
Dust Cover Kit, shock absorber	All Models		<b>AK-735095</b>	

<b>AK-735095</b>	<b>AK-735388</b>	<b>F5-1082</b>	<b>F5-1097</b>	<b>F5-1142</b>	<b>F8-6210</b>	<b>F8-6268</b>
Ref.Nr.: 1J0512131B	Ref.Nr.: BP4K34111C	Ref.Nr.: LW18-18-W11	Ref.Nr.: A6 28X9 2071	Ref.Nr.: L3M6-18-W11	Ref.Nr.: 3M513K155DC	Ref.Nr.: 30639948
<b>F8-6357</b>	<b>F8-6638</b>	<b>F8-7082</b>	<b>F8-7838</b>	<b>F8-8078</b>	<b>F8-8140</b>	
Ref.Nr.: 30714395	Ref.Nr.: C2Y6-28-460	Ref.Nr.: 0515.R0	Ref.Nr.: 1305329	Ref.Nr.: 3M5J-3A262-BP	Ref.Nr.: 30778647	

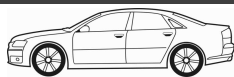
**Article Description****Article Nr.****Fitting Position**

<b>5 (CR19)</b>			<b>02/2005 →</b>		
Dust Cover Kit, shock absorber	All Models		<b>AK-735388</b>		
Alternator Freewheel Clutch	2.0 CD		<b>F5-1097</b>		
Anti-Friction Bearing	All Models		<b>F8-6268</b>		
Top Strut Mounting	1.8, 2.0, 2.0 CD		<b>F8-6357</b>		
Mounting, axle beam	All Models		<b>F8-6638</b>		D=60
Protective Cap/Bellow, shock absorber	All Models		<b>F8-7838</b>		H=250
Control Arm-/Trailing Arm Bush	All Models		<b>F8-8078</b>		
<b>5 (CW)</b>			<b>09/2010 →</b>		
Dust Cover Kit, shock absorber	1.6 CD, 1.8 MZR, 2.0		<b>AK-735388</b>		
Alternator Freewheel Clutch	1.6 CD		<b>F5-1097</b>		
Protective Cap/Bellow, shock absorber	1.6 CD, 1.8 MZR, 2.0		<b>F8-7838</b>		H=250
<b>6 (GG)</b>			<b>06/2002 → 08/2007</b>		
Dust Cover Kit, shock absorber	All Models	ch.→233651; <b>ST</b>	<b>AK-735432</b>		
Dust Cover Kit, shock absorber	All Models	ch.233652→; <b>ST</b>	<b>AK-735433</b>		
Alternator Freewheel Clutch	1.8, 2.0		<b>F5-1063</b>		
Alternator Freewheel Clutch	1.8, 2.0, 2.3		<b>F5-1082</b>		
Alternator Freewheel Clutch	2.0 DI		<b>F5-1097</b>		
Alternator Freewheel Clutch	2.3 MPS Turbo		<b>F5-1142</b>		
Control Arm-/Trailing Arm Bush	1.8, 2.0, 2.0 DI, 2.3		<b>F8-8225</b>		
<b>6 Hatchback (GG)</b>			<b>08/2002 → 08/2007</b>		
Dust Cover Kit, shock absorber	1.8, 2.0, 2.0 DI, 2.3, 2.5	ch.→233651; <b>ST</b>	<b>AK-735432</b>		
Dust Cover Kit, shock absorber	1.8, 2.0, 2.0 DI, 2.3, 2.5	ch.233652→; <b>ST</b>	<b>AK-735433</b>		
Alternator Freewheel Clutch	1.8, 2.0, 2.3		<b>F5-1063</b>		
Alternator Freewheel Clutch	1.8, 2.0, 2.3		<b>F5-1082</b>		
Alternator Freewheel Clutch	2.0 DI		<b>F5-1097</b>		
Control Arm-/Trailing Arm Bush	1.8, 2.0, 2.0 DI, 2.3		<b>F8-8225</b>		
<b>6 Station Wagon (GY)</b>			<b>08/2002 → 08/2007</b>		
Dust Cover Kit, shock absorber	All Models	ch.→233651; <b>ST</b>	<b>AK-735432</b>		
Dust Cover Kit, shock absorber	All Models	ch.233652→; <b>ST</b>	<b>AK-735433</b>		
Alternator Freewheel Clutch	1.8, 2.0, 2.3, 2.3 AWD		<b>F5-1063</b>		
Alternator Freewheel Clutch	1.8, 2.0, 2.3, 2.3 AWD		<b>F5-1082</b>		

<b>AK-735388</b>	<b>AK-735432</b>	<b>AK-735433</b>	<b>F5-1063</b>	<b>F5-1082</b>	<b>F5-1097</b>	<b>F5-1142</b>
Ref.Nr.: BP4K34111C	Ref.Nr.: GJ6A34012	Ref.Nr.: GJ6A34015A	Ref.Nr.:	Ref.Nr.: LW18-18-W11	Ref.Nr.: A6 28X9 2071	Ref.Nr.: L3M6-18-W11
<b>F8-6268</b>	<b>F8-6357</b>	<b>F8-6638</b>	<b>F8-7838</b>	<b>F8-8078</b>	<b>F8-8225</b>	
Ref.Nr.: 30639948	Ref.Nr.: 30714395	Ref.Nr.: C2Y6-28-460	Ref.Nr.: 1305329	Ref.Nr.: 3M5J-3A262-BP	Ref.Nr.: GJ6A-28-200B	

Article Description			Article Nr.	Fitting Position	
<b>6 Station Wagon (GY)</b> <span style="float: right;">08/2002 → 08/2007</span>					
Alternator Freewheel Clutch	2.0 CITD 4x4, 2.0 DI		F5-1097		
Control Arm-/Trailing Arm Bush	1.8, 2.0, 2.0 CITD 4x4, 2.0 DI, 2.3, 2.3 AWD		F8-8225		
<b>6 (GH)</b> <span style="float: right;">08/2007 → 12/2012</span>					
Alternator Freewheel Clutch	2.0 MZR-CD, 2.2 D, 2.2 MZR-CD		F5-1097		
Control Arm-/Trailing Arm Bush	2.0 MZR-CD		F8-8225		
<b>6 Estate (GH)</b> <span style="float: right;">02/2008 →</span>					
Dust Cover Kit, shock absorber	2.5	ch.->233651;	AK-735432		
Dust Cover Kit, shock absorber	2.5	ch.233652->;	AK-735433		
Alternator Freewheel Clutch	2.0 MZR-CD, 2.2 D, 2.2 MRZ-CD, 2.2 MZR-CD		F5-1097		
Control Arm-/Trailing Arm Bush	2.0 MZR-CD		F8-8225		
<b>6 Hatchback (GH)</b> <span style="float: right;">08/2007 →</span>					
Alternator Freewheel Clutch	2.0 MZR-CD, 2.2 D, 2.2 MZR-CD		F5-1097		
Control Arm-/Trailing Arm Bush	2.0 MZR-CD		F8-8225		
<b>121 Mk II (DB)</b> <span style="float: right;">11/1990 → 03/1996</span>					
Dust Cover Kit, shock absorber	1.3 16V, 1.3 i 16V		AK-735386		
Dust Cover Kit, shock absorber	1.3 16V, 1.3 i 16V		AK-735387		
<b>121 Mk III (JASM, JBSM)</b> <span style="float: right;">03/1996 → 04/2003</span>					
Dust Cover Kit, shock absorber	All Models		AK-735017		
Dust Cover Kit, shock absorber	All Models		AK-735082		
Top Strut Mounting	All Models		F8-5410		
Top Strut Mounting	All Models		F8-5412		
Anti-Friction Bearing	All Models		F8-5413		
Stabiliser Mounting	All Models		F8-6034		d=16
Top Strut Mounting	All Models		F8-6312		
Control Arm-/Trailing Arm Bush	All Models		G9-662		H1=44; H2=62; d=12; D1=24; D2=37
Control Arm-/Trailing Arm Bush	All Models		G9-663		H=50; d=12; D=66
<b>323 Mk II (BD)</b> <span style="float: right;">11/1980 → 10/1989</span>					
Dust Cover Kit, shock absorber	1.1, 1.3, 1.5		AK-735085		
<b>323 Mk II Hatchback (BD)</b> <span style="float: right;">11/1980 → 10/1989</span>					
Dust Cover Kit, shock absorber	1.1, 1.3, 1.5		AK-735085		

<b>AK-735017</b>	<b>AK-735082</b>	<b>AK-735085</b>	<b>AK-735386</b>	<b>AK-735387</b>	<b>AK-735432</b>	<b>AK-735433</b>
Ref.Nr.:	Ref.Nr.:	Ref.Nr.: B45534111B	Ref.Nr.: D00134111	Ref.Nr.: D20128015	Ref.Nr.: GJ6A34012	Ref.Nr.: GJ6A34015A
<b>F5-1097</b>	<b>F8-5410</b>	<b>F8-5412</b>	<b>F8-5413</b>	<b>F8-6034</b>	<b>F8-6312</b>	<b>F8-8225</b>
Ref.Nr.: A6 28X9 2071	Ref.Nr.: 1E0028012A	Ref.Nr.: 1E0034390	Ref.Nr.: 1002513	Ref.Nr.: 7102392	Ref.Nr.: 1E003438X	Ref.Nr.: GJ6A-28-200B
<b>G9-662</b>	<b>G9-663</b>					
Ref.Nr.: 1E0034153A	Ref.Nr.: 1063372					





Article Description			Article Nr.	Fitting Position	
<b>323 Mk III (BF)</b> <span style="float: right;">08/1985 → 11/1991</span>					
Dust Cover Kit, shock absorber	1.1, 1.3, 1.5, 1.5 i, 1.5 i Turbo, 1.6 GT, 1.6 GT Turbo, 1.7 D		AK-735085	⊕ ⊕	
<b>323 Mk III Hatchback (BF)</b> <span style="float: right;">08/1985 → 08/1993</span>					
Dust Cover Kit, shock absorber	1.1, 1.3, 1.3 i, 1.4, 1.5, 1.5 i, 1.5 i Turbo, 1.6, 1.6 GT, 1.6 GT Turbo, 1.6 GT Turbo 4WD, 1.7 D		AK-735085	⊕ ⊕	
<b>323 Mk III Estate (BW)</b> <span style="float: right;">05/1986 → 10/1995</span>					
Dust Cover Kit, shock absorber	1.5, 1.6, 1.6 4x4, 1.7 D		AK-735085	⊕ ⊕	
<b>323 C Mk IV (BG)</b> <span style="float: right;">08/1989 → 10/1994</span>					
Dust Cover Kit, shock absorber	1.3, 1.3 16V, 1.6, 1.6 16V, 1.7 D, 1.8 16V, 1.8 16V 4WD, 1.8 16V GT, 1.8 16V Turbo 4WD		AK-735085	⊕ ⊕	
Dust Cover Kit, shock absorber	1.3, 1.3 16V, 1.6, 1.6 16V, 1.7 D, 1.8 16V, 1.8 16V GT		AK-735119	⊕ ⊕	
<b>323 F Mk IV (BG)</b> <span style="float: right;">08/1989 → 10/1994</span>					
Dust Cover Kit, shock absorber	1.6, 1.6 16V, 1.8 16V, 1.8 16V GT		AK-735119	⊕ ⊕	
<b>323 S Mk IV (BG)</b> <span style="float: right;">06/1989 → 10/1994</span>					
Dust Cover Kit, shock absorber	1.3, 1.3 16V, 1.6, 1.6 16V, 1.7 D, 1.8 16V, 1.8 16V 4WD, 1.8 16V GT, 1.8 16V Turbo 4WD		AK-735085	⊕ ⊕	
Dust Cover Kit, shock absorber	1.3, 1.3 16V, 1.6, 1.6 16V, 1.7 D, 1.8 16V, 1.8 16V 4WD, 1.8 16V GT, 1.8 16V Turbo 4WD		AK-735119	⊕ ⊕	
<b>323 C Mk V (BA)</b> <span style="float: right;">08/1994 → 09/1998</span>					
Control Arm-/Trailing Arm Bush	All Models		F8-5284	⊕ ⊕	H=57; d=12; D=40
<b>323 F Mk V (BA)</b> <span style="float: right;">07/1994 → 09/1998</span>					
Control Arm-/Trailing Arm Bush	All Models		F8-5284	⊕ ⊕	H=57; d=12; D=40
<b>323 P Mk V (BA)</b> <span style="float: right;">10/1996 → 09/1998</span>					
Control Arm-/Trailing Arm Bush	All Models		F8-5284	⊕ ⊕	H=57; d=12; D=40
<b>323 S Mk V (BA)</b> <span style="float: right;">05/1994 → 09/1998</span>					
Control Arm-/Trailing Arm Bush	1.3 16V, 1.5 16V, 1.6 TD, 1.8 16V, 2.0 D		F8-5284	⊕ ⊕	H=57; d=12; D=40
<b>323 F/P Mk VI (BJ)</b> <span style="float: right;">09/1998 → 05/2004</span>					
Control Arm-/Trailing Arm Bush	1.4, 1.4 16V, 1.5 16V, 1.6, 1.9 16V, 2.0, 2.0 D, 2.0 TD		F8-6642	⊕ ⊕	H=48; d=16; D=48
<b>323 S Mk VI (BJ)</b> <span style="float: right;">09/1998 → 05/2004</span>					
Control Arm-/Trailing Arm Bush	1.4, 1.4 16V, 1.5 16V, 1.6, 1.9 16V, 2.0, 2.0 D, 2.0 TD		F8-6642	⊕ ⊕	H=48; d=16; D=48
<b>626 Mk II (GC)</b> <span style="float: right;">11/1982 → 09/1987</span>					
Dust Cover Kit, shock absorber	1.6, 2.0, 2.0 D		AK-735112	⊕ ⊕	

<b>AK-735085</b>	<b>AK-735112</b>	<b>AK-735119</b>	<b>F8-5284</b>	<b>F8-6642</b>
Ref.Nr.: B45534111B	Ref.Nr.:	Ref.Nr.:	Ref.Nr.: BC1D34470	Ref.Nr.: B25D34460

Article Description



Article Nr.

Fitting Position



Article Description		Article Nr.	Fitting Position	03/1983 → 09/1987
<b>626 Mk II Hatchback (GC)</b>				
Dust Cover Kit, shock absorber	1.6, 2.0, 2.0 D	AK-735112		
Top Strut Mounting	1.6	F8-4100		H2=55; d=16; D1=96; D2=102
<b>626 Mk III Estate (GV)</b>				
11/1994 → 09/1997				
Control Arm-/Trailing Arm Bush	2.0 D, 2.0 i 16V	F8-5282		
Control Arm-/Trailing Arm Bush	2.0 D, 2.0 i 16V	F8-5283		
<b>626 Mk IV (GE)</b>				
01/1992 → 06/1997				
Dust Cover Kit, shock absorber	1.8 i, 2.0 D GLX Complex, 2.0 i, 2.0 i 4WD	AK-735133		
Dust Cover Kit, shock absorber	1.8 i, 2.0 D GLX Complex, 2.0 i, 2.0 i 4WD	AK-735148		Universal
Anti-Friction Bearing	2.0 D GLX Complex	F8-3020		d=12; d1=12; d2=20; D=54; W=10
Control Arm-/Trailing Arm Bush	1.8 i, 2.0 D GLX Complex, 2.0 i, 2.0 i 4WD	F8-5282		
Control Arm-/Trailing Arm Bush	1.8 i, 2.0 D GLX Complex, 2.0 i, 2.0 i 4WD	F8-5283		
Top Strut Mounting	1.8 i, 2.0 D, 2.0 D GLX Complex, 2.0 i, 2.0 i 4WD	F8-7438		with add-on material
<b>626 Mk IV Hatchback (GE)</b>				
08/1991 → 04/1997				
Dust Cover Kit, shock absorber	All Models	AK-735133		
Dust Cover Kit, shock absorber	All Models	AK-735148		Universal
Control Arm-/Trailing Arm Bush	All Models	F8-5282		
Control Arm-/Trailing Arm Bush	All Models	F8-5283		
Top Strut Mounting	1.8, 2.0 D GLX Complex, 2.0 i, 2.0 i 4WD	F8-7438		with add-on material
<b>626 Mk V (GF)</b>				
05/1997 → 10/2002				
Dust Cover Kit, shock absorber	1.8, 2.0, 2.0 Turbo DI	AK-735134		
<b>626 Mk V Hatchback (GF)</b>				
05/1997 → 10/2002				
Dust Cover Kit, shock absorber	1.8, 2.0, 2.0 H.P., 2.0 Turbo DI	AK-735134		
<b>929 Mk II (HB)</b>				
05/1982 → 07/1987				
Dust Cover Kit, shock absorber	All Models	AK-735082		ch. → HB540489
<b>929 Mk II Coupe (HB)</b>				
05/1982 → 07/1987				
Dust Cover Kit, shock absorber	All Models	AK-735082		
<b>CX-7 (ER)</b>				
10/2007 →				
Alternator Freewheel Clutch	2.2 MZR-CD, 2.2 MZR-CD AWD	F5-1097		
Alternator Freewheel Clutch	2.3 DISI, 2.3 MZR DISI Turbo	F5-1142		

<b>AK-735029</b>	<b>AK-735082</b>	<b>AK-735112</b>	<b>AK-735133</b>	<b>AK-735134</b>	<b>AK-735148</b>	<b>F5-1097</b>
Ref.Nr.:	Ref.Nr.:	Ref.Nr.:	Ref.Nr.:	Ref.Nr.:	Ref.Nr.:	Ref.Nr.: A6 28X9 2071
<b>F5-1142</b>	<b>F8-3020</b>	<b>F8-4100</b>	<b>F8-5282</b>	<b>F8-5283</b>	<b>F8-7438</b>	
Ref.Nr.: L3M6-18-W11	Ref.Nr.: 85BB3K099AA	Ref.Nr.: 344511	Ref.Nr.: GA2A3446YA	Ref.Nr.: GA2A-34-460	Ref.Nr.: 3405806	

**Article Description****Article Nr.****Fitting Position**

<b>Article Description</b>		<b>Article Nr.</b>	<b>Fitting Position</b>	<b>08/1998 → 07/2003</b>
<b>DEMIO (DW)</b>				
Dust Cover Kit, shock absorber	All Models	AK-735029	⊕ ⊕	
<b>MPV Mk II (LW)</b>				<b>09/1999 → 02/2006</b>
Alternator Freewheel Clutch	2.5 V6	F5-1027		
Alternator Freewheel Clutch	2.5 V6	F5-1040		
Alternator Freewheel Clutch	2.0 DI	F5-1097		
<b>MX-3 (EC)</b>				<b>07/1991 → 10/1997</b>
Dust Cover Kit, shock absorber	1.6 i, 1.8 i V6	AK-735395	⊕ ⊕ ⊕	
Dust Cover Kit, shock absorber	1.6 i, 1.8 i V6	AK-735396	⊕ ⊕ ⊕	
<b>PREMACY (CP)</b>				<b>07/1999 → 03/2005</b>
Dust Cover Kit, shock absorber	All Models	AK-735393	⊕ ⊕ ⊕	
Dust Cover Kit, shock absorber	All Models	AK-735394	⊕ ⊕ ⊕	
Control Arm-/Trailing Arm Bush	1.8, 1.9, 2.0, 2.0 TD	F8-6642	⊕ ⊕ ⊕	H=48; d=16; D=48
<b>TRIBUTE (EP)</b>				<b>12/2003 → 05/2008</b>
Alternator Freewheel Clutch	2.3 All-wheel Drive, 2.3 AWD, 2.3 GX	F5-1070		
<b>XEDOS 6 (CA)</b>				<b>01/1992 → 10/1999</b>
Dust Cover Kit, shock absorber	1.6 16V, 2.0 V6	AK-735389	⊕ ⊕ ⊕	
Dust Cover Kit, shock absorber	1.6 16V, 2.0 V6	AK-735390	⊕ ⊕ ⊕	
Dust Cover Kit, shock absorber	1.6 16V, 2.0 V6	AK-735391	⊕ ⊕ ⊕	
Dust Cover Kit, shock absorber	1.6 16V, 2.0 V6	AK-735392	⊕ ⊕ ⊕	

<b>AK-735029</b>	<b>AK-735389</b>	<b>AK-735390</b>	<b>AK-735391</b>	<b>AK-735392</b>	<b>AK-735393</b>	<b>AK-735394</b>
Ref.Nr.:	Ref.Nr.: GA2A34111	Ref.Nr.: GA2A280A5	Ref.Nr.: B01C34111	Ref.Nr.: G30628111	Ref.Nr.: C10034111A	Ref.Nr.: B25D28111
<b>AK-735395</b>	<b>AK-735396</b>	<b>F5-1027</b>	<b>F5-1040</b>	<b>F5-1070</b>	<b>F5-1097</b>	<b>F8-6642</b>
Ref.Nr.: B45534111B	Ref.Nr.: B45528111A	Ref.Nr.: GY02-18-W37Z	Ref.Nr.: 3395459	Ref.Nr.:	Ref.Nr.: A6 28X9 2071	Ref.Nr.: B25D34460

<b>Article Description</b>			<b>Article Nr.</b>	<b>Fitting Position</b>	
----------------------------	--	--	--------------------	-------------------------	--

<b>/8 (W114)</b>		<b>01/1968 → 11/1976</b>			
Control Arm-/Trailing Arm Bush	230.6 , 250, 280, 280 E	<b>F8-4005</b>			H=64.5; d=16.4; D1=42; D2=53
Control Arm-/Trailing Arm Bush	230.6 , 250, 280, 280 E	<b>F8-5688</b>			d=12; D=47; W=28.5
Mounting, axle beam	230.6 , 250, 280, 280 E	<b>F8-5720</b>			
Repair Set, axle beam	230.6 , 280, 280 E	<b>F8-5730</b>			d=16; L=65; D=54
Rubber Buffer, suspension	All Models	<b>F8-5770</b>			H=63
Joint, propshaft	280, 280 E	<b>F8-6235</b>			Bolt Hole Circle Ø [mm]=90

<b>/8 Coupe (W114)</b>		<b>04/1969 → 02/1977</b>			
Control Arm-/Trailing Arm Bush	All Models	<b>F8-4005</b>			H=64.5; d=16.4; D1=42; D2=53
Control Arm-/Trailing Arm Bush	250 C , 250 C 2.8 , 280 C , 280 CE	<b>F8-5688</b>			d=12; D=47; W=28.5
Mounting, axle beam	250 C , 250 C 2.8 , 280 C , 280 CE	<b>F8-5720</b>			
Repair Set, axle beam	250 C , 250 C 2.8 , 280 C , 280 CE	<b>F8-5730</b>			d=16; L=65; D=54
Rubber Buffer, suspension	All Models	<b>F8-5770</b>			H=63
Joint, propshaft	280 C , 280 CE	<b>F8-6235</b>			Bolt Hole Circle Ø [mm]=90

<b>/8 (W115)</b>		<b>01/1968 → 01/1977</b>			
Repair Kit, reversing lever	200, 200 D , 220, 220 D , 230.4 , 240 D , 240 D 3.0	<b>F7-9001</b>			
Control Arm-/Trailing Arm Bush	200, 200 D , 220, 220 D , 230.4 , 240 D , 240 D 3.0	<b>F8-4005</b>			H=64.5; d=16.4; D1=42; D2=53
Control Arm-/Trailing Arm Bush	All Models	<b>F8-5688</b>			d=12; D=47; W=28.5
Mounting, axle beam	All Models	<b>F8-5720</b>			
Repair Set, axle beam	All Models	<b>F8-5730</b>			d=16; L=65; D=54
Rubber Buffer, suspension	All Models	<b>F8-5770</b>			H=63

<b>190 (W201)</b>		<b>10/1982 → 08/1993</b>			
Dust Cover Kit, shock absorber	2.0 , D 2.0 , D 2.5 , E 1.8 , E 2.0 , E 2.3 , E 2.6, Turbo-D 2.5	<b>AK-735019</b>			
Engine Mounting	2.0	<b>F7-2003</b>			
Engine Mounting	D 2.0	<b>F7-2003</b>			
Engine Mounting	D 2.5	<b>F7-2003</b>			
Engine Mounting	E 1.8	<b>F7-2003</b>			
Engine Mounting	E 2.0 , E 2.3	ch.A136174, F025325→;			
Mounting, automatic transmission	D 2.0	ch.→A 201388, F 086255	<b>F7-2069</b>		H=63; L=127; Thick. [mm]=53
Engine Mounting	E 2.6		<b>F8-2005</b>		
Engine Mounting	Turbo-D 2.5		<b>F8-2005</b>		

<b>AK-735019</b>	<b>F7-2003</b>	<b>F7-2069</b>	<b>F7-9001</b>	<b>F8-2005</b>	<b>F8-4005</b>	<b>F8-5005</b>
Ref.Nr.: 1293230192	Ref.Nr.: 1242400217	Ref.Nr.: 2012400318	Ref.Nr.: 1234600050	Ref.Nr.: 1242401917	Ref.Nr.: 1153523265	Ref.Nr.: 1242400317
<b>F8-5688</b>	<b>F8-5720</b>	<b>F8-5730</b>	<b>F8-5770</b>	<b>F8-6235</b>		
Ref.Nr.: 1153333014	Ref.Nr.: 1073300275	Ref.Nr.: 1153523665	Ref.Nr.: 1153200344	Ref.Nr.: 1264100215		



Article Description



Article Nr.

Fitting Position



190 (W201)			10/1982 → 08/1993		
Engine Mounting	2.0	09/1988 →; *	F8-5005		H=111; D1=90; D2=103
Engine Mounting	D 2.5	♣; *	F8-5005		H=111; D1=90; D2=103
Engine Mounting	E 2.0	ch.A136174, F025325 →; *	F8-5005		H=111; D1=90; D2=103
Engine Mounting	E 2.3, E 2.5-16, E Evolution II 2.5	♣	F8-5005		H=111; D1=90; D2=103
Engine Mounting	E 2.3-16		F8-5005		H=111; D1=90; D2=103
Engine Mounting	E 2.6	♣, ♣; *	F8-5005		H=111; D1=90; D2=103
Engine Mounting	Turbo-D 2.5	♣	F8-5005		H=111; D1=90; D2=103
Suspension Kit	2.0, E 2.0	ch.→A675431, F920107; 09/1988 →; <b>SP</b>	F8-5009	⊕ ⊕	
Suspension Kit	D 2.0, D 2.5, E 1.8	ch.→A675431, F920107; <b>SP</b>	F8-5009	⊕ ⊕	
Suspension Kit	E 2.3, E 2.6, Turbo-D 2.5	ch.→A675431, F920107	F8-5009	⊕ ⊕	
Control Arm-/Trailing Arm Bush	2.0, D 2.0, D 2.5, E 1.8, E 2.0		F8-5010	⊕ ⊕ ⊕ ↓	H=49; d=16; D1=49; D2=65
Suspension Kit	2.0, D 2.0, D 2.5, E 2.0	ch.→A675431, F920107; 09/1988 →; <b>SP</b>	F8-5011	⊕ ⊕	
Suspension Kit	2.0, D 2.0, E 1.8	ch.→A675431, F920107; <b>SP</b>	F8-5011	⊕ ⊕	
Suspension Kit	E 2.0	ch.→A675431, F920107; 09/1988 →;  M 102.961; <b>SP</b>	F8-5011	⊕ ⊕	
Suspension Kit	E 2.0	ch.→A675431, F920107;  M 102.961; <b>SP</b>	F8-5011	⊕ ⊕	
Joint, propshaft	2.0, D 2.0, D 2.5, E 2.0	with add-on material	F8-5015		d=34; D=128
Joint, propshaft	2.0, D 2.0, D 2.5, E 2.0	Joint Type: Hard Version; with fastening material	F8-5016		H=26; d=40; Mounting points diam.[mm]=10.2; D=116
Mounting, axle beam	2.0, D 2.0, D 2.5, E 1.8, E 2.0, E 2.3, E 2.3-16, E 2.5-16, E 2.6, E Evolution II 2.5, Turbo-D 2.5		F8-5018		H=58; D1=68; D2=81
Repair Kit, link	E 2.3-16, E Evolution II 2.5		F8-5185	⊕ ⊕ ⊕ ↓	
Repair Kit, link	E 2.5-16	ch.→F920107	F8-5185	⊕ ⊕ ⊕ ↓	
Suspension Kit	D 2.0, D 2.5, E 2.3, E 2.6, Turbo-D 2.5	ch.A675432, F920108 →; 09/1988 →; <b>SP</b>	F8-5195	⊕ ⊕	
Suspension Kit	D 2.0, E 1.8	ch.A675432, F920108 →; <b>SP</b>	F8-5195	⊕ ⊕	
Suspension Kit	E 2.0	ch.A675432, F920108 →; 09/1988 →;  M 102.961; <b>SP</b>	F8-5195	⊕ ⊕	
Suspension Kit	E 2.0	ch.A675432, F920108 →;  M 102.961; <b>SP</b>	F8-5195	⊕ ⊕	
Stabiliser Mounting	D 2.5		F8-5209		H=36; d=22.5; D=38
Stabiliser Mounting	D 2.5, E 2.6, Turbo-D 2.5	09/1988 →	F8-5209		H=36; d=22.5; D=38
Stabiliser Mounting	E 2.6		F8-5214	⊕ ⊕	d=18
Stabiliser Mounting	2.0, D 2.0, D 2.5, E 1.8, E 2.0, E 2.3, Turbo-D 2.5		F8-5218	⊕ ⊕	d=23
Stabiliser Mounting	D 2.5, Turbo-D 2.5		F8-5219	⊕ ⊕	d=24
Control Arm-/Trailing Arm Bush	2.0, D 2.0, D 2.5, E 1.8, E 2.0, E 2.3, E 2.3-16, E 2.5-16, E 2.6, E Evolution II 2.5, Turbo-D 2.5		F8-5297	⊕ ⊕ ⊕ ↓	H=48; d=14.1; D=40.03

<b>F8-5005</b>	<b>F8-5009</b>	<b>F8-5010</b>	<b>F8-5011</b>	<b>F8-5015</b>	<b>F8-5016</b>	<b>F8-5018</b>
Ref.Nr.: 1242400317	Ref.Nr.: 1243300275	Ref.Nr.: 2013335114	Ref.Nr.: 2013300075	Ref.Nr.: 1244100015	Ref.Nr.: 2014102115	Ref.Nr.: 2013512742
<b>F8-5185</b>	<b>F8-5195</b>	<b>F8-5209</b>	<b>F8-5214</b>	<b>F8-5218</b>	<b>F8-5219</b>	<b>F8-5297</b>
Ref.Nr.: 2013300175	Ref.Nr.: 1243300675	Ref.Nr.: 1243235085	Ref.Nr.: 1243234985	Ref.Nr.: 2013234985	Ref.Nr.: 1243233785	Ref.Nr.: 2043520027
<b>F8-5327</b>						
Ref.Nr.: 1243523565						

Article Description



Article Nr.

Fitting Position



190 (W201)				10/1982 → 08/1993	
Control Arm-/Trailing Arm Bush	2.0, D 2.0, D 2.5, E 1.8, E 2.0, E 2.3, E 2.3-16, E 2.5-16, E 2.6, E Evolution II 2.5, Turbo-D 2.5		F8-5327		d=11; D=36
Engine Mounting	D 2.5		F8-5449		
Engine Mounting	E 2.6		F8-5449		
Engine Mounting	Turbo-D 2.5	09/1988 →;	F8-5449		
Engine Mounting	Turbo-D 2.5		F8-5449		
Repair Kit, reversing lever	2.0, D 2.0, D 2.5, E 1.8, E 2.0, E 2.3, E 2.3-16, E 2.5-16, E 2.6, E Evolution II 2.5, Turbo-D 2.5		F8-5582		
Top Strut Mounting	All Models		F8-5613		
Stabiliser Mounting	2.0, D 2.0, D 2.5, E 2.0, E 2.3		F8-5670		d=13
Stabiliser Mounting	E 2.0	M 102.961	F8-5670		d=13
Control Arm-/Trailing Arm Bush	E 2.3-16, E 2.5-16, E Evolution II 2.5		F8-5678		H=58; d=12; D=33
Repair Set, axle beam	2.0, D 2.0, D 2.5, E 1.8, E 2.0, E 2.3, E 2.3-16, E 2.5-16, E 2.6, E Evolution II 2.5, Turbo-D 2.5	with fastening material; with accessories	F8-5697		
Control Arm-/Trailing Arm Bush	2.0, D 2.0, D 2.5, E 1.8, E 2.0, E 2.3, E 2.3-16, E 2.5-16, E 2.6, E Evolution II 2.5, Turbo-D 2.5		F8-5698		
Rubber Buffer, suspension	2.0, D 2.0, D 2.5, E 2.0, E 2.3, E 2.3-16, E 2.6, Turbo-D 2.5		F8-5901		
Rubber Buffer, suspension	2.0, D 2.0, D 2.5, E 1.8, E 2.0, E 2.3, E 2.6, Turbo-D 2.5		F8-5914		H=75
Repair Set, axle beam	2.0, D 2.0, D 2.5, E 1.8, E 2.0, E 2.3, E 2.3-16, E 2.5-16, E 2.6, E Evolution II 2.5, Turbo-D 2.5	with fastening material	F8-6230		
Control Arm-/Trailing Arm Bush	All Models		F8-6468		H=48; d=16; D=49
Suspension Kit	All Models		F8-6473		
Mounting, manual transmission	2.0, E 2.0, E 2.3-16	ch.A136174, F025325→	F8-6498		
Mounting, manual transmission	D 2.0	ch.A201389, F086256→	F8-6498		
Mounting, manual transmission	D 2.0		F8-6498		
Mounting, manual transmission	D 2.5, E 1.8, E 2.3, E 2.3-16, E 2.5-16, E 2.6, E Evolution II 2.5, Turbo-D 2.5		F8-6498		
Mounting, manual transmission	E 2.0	ch.A136174, F025325→;  M 102.961	F8-6498		
Mounting, manual transmission	Turbo-D 2.5	09/1988 →; Type: 201.128	F8-6498		
Control Arm-/Trailing Arm Bush	D 2.0, D 2.5, E 1.8		F8-6804		
Control Arm-/Trailing Arm Bush	D 2.0, D 2.5, E 2.0, E 2.3, E 2.6, Turbo-D 2.5	09/1988 →;	F8-6804		
Control Arm-/Trailing Arm Bush	D 2.0, D 2.5, E 1.8		F8-6805		
Control Arm-/Trailing Arm Bush	D 2.0, D 2.5, E 2.0, E 2.3, E 2.6, Turbo-D 2.5	09/1988 →;	F8-6805		

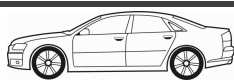

**Article Description****Article Nr.****Fitting Position****190 (W201) 10/1982 → 08/1993**

Mounting, propshaft	2.0, D 2.0, D 2.5, E 1.8, E 2.0, E 2.3, E 2.3-16, E 2.5-16, E 2.6, E Evolution II 2.5, Turbo-D 2.5		<b>F8-7054</b>		d=47
Mounting, propshaft	D 2.0	; Type: 201.122	<b>F8-7054</b>		d=47
Mounting, propshaft	E 2.3-16	; Type: 201.034	<b>F8-7054</b>		d=47
Joint, propshaft	2.0, D 2.0, D 2.5, E 1.8, E 2.0, E 2.3, E 2.6, Turbo-D 2.5	with add-on material	<b>F8-7130</b>		Bolt Hole Circle Ø [mm]=90
Control Arm-/Trailing Arm Bush	2.0, D 2.0, D 2.5, E 1.8, E 2.0, E 2.3, E 2.3-16, E 2.5-16, E 2.6, E Evolution II 2.5, Turbo-D 2.5		<b>G9-503</b>		H=43; d=12; D=31
Control Arm-/Trailing Arm Bush	2.0, D 2.0, D 2.5, E 1.8, E 2.0, E 2.3, E 2.3-16, E 2.5-16, E 2.6, E Evolution II 2.5, Turbo-D 2.5		<b>G9-651</b>		d=12
Control Arm-/Trailing Arm Bush	2.0, D 2.0, D 2.5, E 1.8, E 2.0, E 2.3, E 2.3-16, E 2.5-16, E 2.6, E Evolution II 2.5, Turbo-D 2.5		<b>G9-652</b>		d=13
Control Arm-/Trailing Arm Bush	2.0, D 2.0, D 2.5, E 2.0		<b>G9-667</b>		H=48; d=14; W1=53; W2= 49
Control Arm-/Trailing Arm Bush	E 1.8		<b>G9-667</b>		H=48; d=14; W1=53; W2= 49

**A-CLASS (W168) 07/1997 → 08/2004**

Dust Cover Kit, shock absorber	All Models		<b>AK-735221</b>		
Alternator Freewheel Clutch	A 210		<b>F5-1026</b>		
Alternator Freewheel Clutch	A 160 CDI		<b>F5-1121</b>		
Control Arm-/Trailing Arm Bush	A 140, A 160, A 160 CDI, A 170 CDI, A 190		<b>F8-5325</b>		
Control Arm-/Trailing Arm Bush	A 140, A 160, A 160 CDI, A 170 CDI, A 190, A 210		<b>F8-5326</b>		
Repair Kit, suspension strut	All Models		<b>F8-5834</b>		
Suspension Kit	A 140, A 160, A 160 CDI, A 170 CDI, A 190, A 210		<b>F8-6100</b>		
Belt Pulley, crankshaft	A 140, A 160	Number of Ribs: 5;	<b>F8-6400</b>		
Belt Pulley, crankshaft	A 160 CDI, A 170 CDI, A 190, A 210	Number of Ribs: 5	<b>F8-6400</b>		
Engine Mounting	A 140, A 160, A 160 CDI, A 170 CDI, A 190, A 210		<b>F8-8126</b>		
Engine Mounting	A 140, A 160, A 160 CDI, A 170 CDI, A 190, A 210		<b>F8-8154</b>		

**A-CLASS (W169) 09/2004 → 06/2012**

Dust Cover Kit, shock absorber	A 150, A 160, A 160 CDI, A 170, A 180, A 180 CDI, A 200, A 200 CDI, A 200 TURBO		<b>AK-735222</b>		
Alternator Freewheel Clutch	A 150, A 160, A 170, A 180, A 200, A 200 TURBO		<b>F5-1081</b>		
Alternator Freewheel Clutch	A 160 CDI, A 180 CDI, A 200 CDI	for vehicles without start-stop function	<b>F5-1121</b>		
Top Strut Mounting	A 150, A 160, A 160 CDI, A 170, A 180, A 180 CDI, A 200, A 200 CDI, A 200 TURBO		<b>F8-6518</b>		
Engine Mounting	A 200 TURBO		<b>F8-6643</b>		
Engine Mounting	A 150, A 160 CDI, A 170, A 180 CDI, A 200, A 200 CDI, A 200 TURBO	5-speed	<b>F8-6644</b>		

<b>AK-735221</b>	<b>AK-735222</b>	<b>F5-1026</b>	<b>F5-1081</b>	<b>F5-1121</b>	<b>F8-5325</b>	<b>F8-5326</b>
Ref.Nr.: 1683230192	Ref.Nr.: 1693230192	Ref.Nr.: 1661550215	Ref.Nr.: 2661550115	Ref.Nr.: 6681550215	Ref.Nr.: 1683330214	Ref.Nr.: 1683330014
<b>F8-5834</b>	<b>F8-6100</b>	<b>F8-6400</b>	<b>F8-6518</b>	<b>F8-6643</b>	<b>F8-6644</b>	<b>F8-6645</b>
Ref.Nr.: 1683200073	Ref.Nr.: 1683570771	Ref.Nr.: 166 030 0303	Ref.Nr.: 1693200073	Ref.Nr.: 1692400817	Ref.Nr.: 1692400518	Ref.Nr.: 1692400618
<b>F8-7054</b>	<b>F8-7130</b>	<b>F8-8126</b>	<b>F8-8154</b>	<b>G9-503</b>	<b>G9-651</b>	<b>G9-652</b>
Ref.Nr.: 2014100581	Ref.Nr.: 1264100515	Ref.Nr.: A1682401617	Ref.Nr.: 1682400618	Ref.Nr.: 1243524365	Ref.Nr.: 1243529065	Ref.Nr.: 1243528665

Article Description

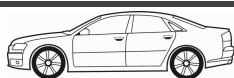

Article Nr.

Fitting Position



<b>A-CLASS (W169)</b>		<b>09/2004 → 06/2012</b>	
Engine Mounting	A 150, A 160 CDI, A 170, A 180 CDI, A 200, A 200 CDI, A 200 TURBO	F8-6645	⊕
Engine Mounting	A 150, A 160 CDI, A 170, A 180 CDI, A 200, A 200 CDI, A 200 TURBO	Transmission Type: CVT (Stepless)	F8-6646 ⊕
<b>A-CLASS (W176)</b>		<b>06/2012 →</b>	
Protective Cap/Bellow, shock absorber	A 160 CDI, A 180, A 180 CDI, A 200, A 200 CDI, A 220 CDI, A 250, A 250 4-matic, A 45 AMG 4-matic	for vehicles without electronic drive dynamics regulation	F8-7899  ⊕ ⊕ H=224
<b>B-CLASS (W245)</b>		<b>03/2005 → 11/2011</b>	
Dust Cover Kit, shock absorber	B 150, B 170, B 180 CDI, B 200, B 200 CDI, B 200 TURBO	AK-735222	⊕ ⊕
Alternator Freewheel Clutch	B 150, B 160, B 170, B 170 NGT, B 180, B 180 NGT, B 200, B 200 TURBO	F5-1081	
Alternator Freewheel Clutch	B 180 CDI	for vehicles without start-stop function	F5-1121
Alternator Freewheel Clutch	B 200 CDI	Alternator Charge Current [A]: 140; Manufacturer Restriction: VALEO; for vehicles without start-stop function	F5-1121
Top Strut Mounting	B 150, B 160, B 170, B 170 NGT, B 180, B 180 CDI, B 180 NGT, B 200, B 200 CDI, B 200 TURBO		F8-6518  ⊕ ⊕
Engine Mounting	B 200 TURBO		F8-6643  ⊕ ⊕
Engine Mounting	B 150, B 170, B 180 CDI, B 200, B 200 CDI, B 200 TURBO	5-speed	F8-6644 ⊕
Engine Mounting	B 150, B 170, B 180 CDI, B 200, B 200 CDI, B 200 TURBO		F8-6645 ⊕
Engine Mounting	B 150, B 170, B 180 CDI, B 200, B 200 CDI, B 200 TURBO	Transmission Type: CVT (Stepless)	F8-6646 ⊕
<b>B-CLASS (W246, W242)</b>		<b>11/2011 →</b>	
Protective Cap/Bellow, shock absorber	B 160 CDI, B 180, B 180 CDI, B 200, B 200 CDI, B 200 Natural Gas Drive, B 220 4-matic, B 220 CDI, B 250	for vehicles without electronic drive dynamics regulation	F8-7899  ⊕ ⊕ H=224
<b>CABRIOLET (A124)</b>		<b>04/1992 → 06/1993</b>	
Dust Cover Kit, shock absorber	300 CE-24	AK-735019	⊕ ⊕
Repair Kit, reversing lever	300 CE-24	F7-9001	⊕
Suspension Kit	300 CE-24	ch.→B711095	F8-5009  ⊕ ⊕
Control Arm-/Trailing Arm Bush	300 CE-24		F8-5010  ⊕ ⊕ ⊕ ↓ H=49; d=16; D1=49; D2=65
Suspension Kit	300 CE-24	ch.B711096→	F8-5195  ⊕ ⊕
Stabiliser Mounting	300 CE-24		F8-5216  d=28.5
Control Arm-/Trailing Arm Bush	300 CE-24		F8-5297  ⊕ ⊕ ⊕ ↓ H=48; d=14.1; D=40.03
Control Arm-/Trailing Arm Bush	300 CE-24		F8-5327  d=11; D=36

<b>AK-735019</b>	<b>AK-735222</b>	<b>F5-1081</b>	<b>F5-1121</b>	<b>F7-9001</b>	<b>F8-5009</b>	<b>F8-5010</b>
Ref.Nr.: 1293230192	Ref.Nr.: 1693230192	Ref.Nr.: 2661550115	Ref.Nr.: 6681550215	Ref.Nr.: 1234600050	Ref.Nr.: 1243300275	Ref.Nr.: 2013335114
<b>F8-5195</b>	<b>F8-5216</b>	<b>F8-5297</b>	<b>F8-5327</b>	<b>F8-5502</b>	<b>F8-6518</b>	<b>F8-6643</b>
Ref.Nr.: 1243300675	Ref.Nr.: 1243232885	Ref.Nr.: 2043520027	Ref.Nr.: 1243523565	Ref.Nr.: A1243201444	Ref.Nr.: 1693200073	Ref.Nr.: 1692400817
<b>F8-6644</b>	<b>F8-6645</b>	<b>F8-6646</b>	<b>F8-7899</b>			
Ref.Nr.: 1692400518	Ref.Nr.: 1692400618	Ref.Nr.: 1692401218	Ref.Nr.: 2123230392			





Article Description



Article Nr.

Fitting Position



<b>CABRIOLET (A124)</b>			<b>04/1992 → 06/1993</b>		
Top Strut Mounting	300 CE-24		<b>F8-5502</b>		d=14.5; D=59; Thick. [mm]=130
Control Arm-/Trailing Arm Bush	300 CE-24		<b>F8-5678</b>		H=58; d=12; D=33
Mounting, axle beam	300 CE-24		<b>F8-5733</b>		H=30; d=14; D=47
Mounting, axle beam	300 CE-24		<b>F8-5744</b>		
Mounting, axle beam	300 CE-24		<b>F8-5773</b>		H=70; D=70
Repair Set, axle beam	300 CE-24		<b>F8-5820</b>		
Mounting, axle beam	300 CE-24		<b>F8-5821</b>		H=59; d=16; D=66
Rubber Buffer, suspension	300 CE-24		<b>F8-5901</b>		
Rubber Buffer, suspension	300 CE-24		<b>F8-5914</b>		H=75
Rubber Buffer, suspension	300 CE-24		<b>F8-5918</b>		
Joint, propshaft	300 CE-24	with fastening material	<b>F8-6239</b>		Bolt Hole Circle Ø [mm]=100; d=46; D=140; W=29.8
Control Arm-/Trailing Arm Bush	300 CE-24		<b>F8-6468</b>		H=48; d=16; D=49
Mounting, manual transmission	300 CE-24		<b>F8-6498</b>		
Control Arm-/Trailing Arm Bush	300 CE-24	ch.B711096→	<b>F8-6804</b>		
Control Arm-/Trailing Arm Bush	300 CE-24	ch.B711096→	<b>F8-6805</b>		
Control Arm-/Trailing Arm Bush	300 CE-24		<b>G9-503</b>		H=43; d=12; D=31
Control Arm-/Trailing Arm Bush	300 CE-24		<b>G9-651</b>		d=12
Control Arm-/Trailing Arm Bush	300 CE-24		<b>G9-652</b>		d=13
<b>C-CLASS (W202)</b>			<b>03/1993 → 05/2000</b>		
Alternator Freewheel Clutch	C 200 D , C 220 D , C 250 D , C 250 Turbo-D		<b>F5-1003</b>		
Alternator Freewheel Clutch	C 200 CDI , C 220 CDI		<b>F5-1017</b>		
Alternator Freewheel Clutch	C 200 CDI , C 220 CDI		<b>F5-1019</b>		
Vibration Damper, propshaft	C 180 , C 200 D , C 220 D		<b>F8-5017</b>		d=37; D=135
Mounting, axle beam	C 180 , C 200 , C 200 D , C 200 Kompressor , C 220 , C 220 D , C 230 Kompressor , C 250 D , C 250 Turbo-D , C 280 , C 36 AMG		<b>F8-5018</b>		H=58; D1=68; D2=81
Suspension Kit	All Models	ch.→A443812, F500865	<b>F8-5023</b>		
Repair Kit, reversing lever	C 180 , C 200 , C 200 D , C 200 Kompressor , C 220 , C 220 D , C 230 Kompressor , C 250 D , C 250 Turbo-D , C 280 , C 36 AMG		<b>F8-5181</b>		D=28; H=56; d=10
Suspension Kit	C 180 , C 200 , C 200 D , C 200 Kompressor , C 220 , C 220 D , C 230 , C 230 Kompressor , C 250 D , C 250 Turbo-D , C 280 , C 36 AMG	ch.A443813, F500866→	<b>F8-5197</b>		

<b>F5-1003</b>	<b>F5-1017</b>	<b>F5-1019</b>	<b>F8-5017</b>	<b>F8-5018</b>	<b>F8-5023</b>	<b>F8-5181</b>
Ref.Nr.: 6041500060	Ref.Nr.: 6111500160	Ref.Nr.: 5117591AA	Ref.Nr.: 2024100747	Ref.Nr.: 2013512742	Ref.Nr.: 2023300075	Ref.Nr.: 2024600319
<b>F8-5197</b>	<b>F8-5502</b>	<b>F8-5678</b>	<b>F8-5733</b>	<b>F8-5744</b>	<b>F8-5773</b>	<b>F8-5820</b>
Ref.Nr.: 1703300075	Ref.Nr.: A1243201444	Ref.Nr.: 1293520065	Ref.Nr.: 1243524165	Ref.Nr.: 1243511342	Ref.Nr.: 1243510242	Ref.Nr.: 1243508608
<b>F8-5821</b>	<b>F8-5901</b>	<b>F8-5914</b>	<b>F8-5918</b>	<b>F8-6239</b>	<b>F8-6468</b>	<b>F8-6498</b>
Ref.Nr.: 1293511542	Ref.Nr.: 2013232044	Ref.Nr.: 1293230744	Ref.Nr.: 1243230744	Ref.Nr.: 1704100015	Ref.Nr.: 201 333 52 14	Ref.Nr.: 1242400018

Article Description



Article Nr.

Fitting Position



**C-CLASS (W202)**

03/1993 → 05/2000

Suspension Kit	C 200 CDI , C 220 CDI , C 240 , C 280 , C 43 AMG		<b>F8-5197</b>		
Stabiliser Mounting	C 180 , C 200 , C 200 D , C 220 , C 220 D , C 230		<b>F8-5214</b>		d=18
Stabiliser Mounting	C 180 , C 200 , C 200 D , C 200 Kompressor , C 220 , C 220 CDI , C 220 D , C 230 , C 230 Kompressor , C 240 , C 250 D , C 250 Turbo-D , C 280 , C 36 AMG		<b>F8-5217</b>		d=26.5
Stabiliser Mounting	C 43 AMG	ch.A569193, F668976→	<b>F8-5222</b>		d=30
Stabiliser Mounting	C 180 , C 200 , C 200 D , C 220 , C 220 D , C 230		<b>F8-5227</b>		d=23
Stabiliser Mounting	C 180	M 111.920; <b>SP</b>	<b>F8-5236</b>		H=38; d=24; D=45
Stabiliser Mounting	C 200	M 111.941; <b>SP</b>	<b>F8-5236</b>		H=38; d=24; D=45
Stabiliser Mounting	C 200 D , C 220 , C 220 D , C 230	<b>SP</b>	<b>F8-5236</b>		H=38; d=24; D=45
Control Arm-/Trailing Arm Bush	All Models		<b>F8-5297</b>		H=48; d=14.1; D=40.03
Control Arm-/Trailing Arm Bush	C 180	ch.F500866→	<b>F8-5307</b>		H=43; d=20; D=70
Control Arm-/Trailing Arm Bush	C 180 , C 200 CDI , C 200 Kompressor , C 220 CDI , C 220 D , C 240 , C 280 , C 43 AMG		<b>F8-5307</b>		H=43; d=20; D=70
Control Arm-/Trailing Arm Bush	C 200 , C 200 D , C 200 Kompressor , C 220 , C 220 D , C 230 , C 230 Kompressor , C 250 D , C 250 Turbo-D , C 280 , C 36 AMG	ch.A443813, F500866→	<b>F8-5307</b>		H=43; d=20; D=70
Mounting, manual transmission	C 240 , C 280		<b>F8-5308</b>		H=75; L=110
Control Arm-/Trailing Arm Bush	C 180 , C 200 , C 200 CDI , C 200 D , C 200 Kompressor , C 220 , C 220 CDI , C 220 D , C 230 , C 230 Kompressor , C 240 , C 250 D , C 250 Turbo-D , C 280 , C 36 AMG , C 43 AMG		<b>F8-5327</b>		d=11; D=36
Engine Mounting	C 180 , C 200	ch.→A436535, F483847	<b>F8-5460</b>		
Engine Mounting	C 180 , C 200 CDI , C 200 D , C 220 , C 220 D , C 230 , C 230 Kompressor		<b>F8-5460</b>		
Engine Mounting	C 180 , C 200	ch.→A436535, F483847	<b>F8-5461</b>		
Engine Mounting	C 200 D , C 220 , C 220 D		<b>F8-5461</b>		
Control Arm-/Trailing Arm Bush	All Models		<b>F8-5477</b>		
Belt Pulley, crankshaft	All Models	Parameter: 6PK	<b>F8-5663</b>		d=32; D1=160; D2=157; W1=82
Control Arm-/Trailing Arm Bush	All Models		<b>F8-5678</b>		H=58; d=12; D=33
Repair Set, axle beam	All Models	with fastening material; with accessories	<b>F8-5697</b>		
Control Arm-/Trailing Arm Bush	C 180 , C 200 , C 200 CDI , C 200 D , C 200 Kompressor , C 220 , C 220 CDI , C 220 D , C 230 , C 230 Kompressor , C 240 , C 250 D , C 250 Turbo-D , C 280 , C 36 AMG , C 43 AMG		<b>F8-5698</b>		
Repair Set, axle beam	All Models	with fastening material	<b>F8-6230</b>		
Joint, propshaft	C 200 CDI , C 220 CDI , C 230 Kompressor , C 250 Turbo-D , C 280 , C 36 AMG	with fastening material	<b>F8-6239</b>		Bolt Hole Circle Ø [mm]=100; d=46; D=140; W=29.8





Article Description



Article Nr.

Fitting Position



## C-CLASS (W202) 03/1993 → 05/2000

Joint, propshaft	C 200 Kompressor	ch.F381314→; with fastening material; Type: 202.025	<b>F8-6239</b>		Bolt Hole Circle Ø [mm]=100; d=46; D=140; W=29.8
Joint, propshaft	C 250 Turbo-D	with fastening material;	<b>F8-6239</b>		Bolt Hole Circle Ø [mm]=100; d=46; D=140; W=29.8
Joint, propshaft	C 280	ch.→A436535; with fastening material	<b>F8-6239</b>		Bolt Hole Circle Ø [mm]=100; d=46; D=140; W=29.8
Joint, propshaft	C 280	ch.→F483847; with fastening material;	<b>F8-6239</b>		Bolt Hole Circle Ø [mm]=100; d=46; D=140; W=29.8
Rubber Buffer, suspension	All Models		<b>F8-6466</b>		
Suspension Kit	All Models	with fastening material	<b>F8-6474</b>		
Control Arm-/Trailing Arm Bush	All Models		<b>F8-6813</b>		H=99; d=10; W=48
Control Arm-/Trailing Arm Bush	All Models		<b>F8-6814</b>		
Engine Mounting	C 180 , C 200 , C 200 D , C 200 Kompressor , C 220 , C 220 D , C 230 Kompressor , C 250 D , C 250 Turbo-D , C 280 , C 36 AMG	ch.→A436535, F483847;  4-speed	<b>F8-6924</b>		
Engine Mounting	C 180 , C 200 , C 230	ch.→A568090, F675418; Aluminium;  5-speed	<b>F8-7747</b>		L=104
Engine Mounting	C 220 D , C 280 , C 36 AMG	Aluminium;  5-speed	<b>F8-7747</b>		L=104
Mounting, manual transmission	C 180 , C 200 , C 200 D , C 200 Kompressor , C 220 , C 220 CDI , C 220 D , C 230 , C 230 Kompressor , C 250 D , C 250 Turbo-D , C 280 , C 36 AMG		<b>F8-8178</b>		
Control Arm-/Trailing Arm Bush	All Models		<b>G9-503</b>		H=43; d=12; D=31
Control Arm-/Trailing Arm Bush	All Models		<b>G9-651</b>		d=12
Control Arm-/Trailing Arm Bush	All Models		<b>G9-652</b>		d=13

## C-CLASS Estate (S202) 06/1996 → 03/2001

Alternator Freewheel Clutch	C 200 T D , C 220 T D , C 250 T Turbo-D		<b>F5-1003</b>		
Alternator Freewheel Clutch	C 200 T CDI , C 220 T CDI		<b>F5-1017</b>		
Alternator Freewheel Clutch	C 200 T CDI , C 220 T CDI		<b>F5-1019</b>		
Vibration Damper, propshaft	C 180 T , C 200 T D , C 220 T D		<b>F8-5017</b>		d=37; D=135
Mounting, axle beam	C 180 T , C 200 T , C 220 T D , C 230 T , C 250 T Turbo-D		<b>F8-5018</b>		H=58; D1=68; D2=81
Suspension Kit	C 180 T , C 200 T , C 200 T D , C 200 T Kompressor , C 220 T D , C 230 T , C 230 T Kompressor , C 250 T Turbo-D	ch.→F500865	<b>F8-5023</b>		
Suspension Kit	C 180 T , C 200 T CDI , C 200 T Kompressor , C 220 T CDI , C 220 T D , C 240 T , C 280 T , C 43 AMG	ch.→A443812, F500865	<b>F8-5023</b>		
Repair Kit, reversing lever	C 180 T , C 200 T , C 220 T D , C 230 T , C 250 T Turbo-D		<b>F8-5181</b>		D=28; H=56; d=10

<b>F5-1003</b>	<b>F5-1017</b>	<b>F5-1019</b>	<b>F8-5017</b>	<b>F8-5018</b>	<b>F8-5023</b>	<b>F8-5181</b>
Ref.Nr.: 6041500060	Ref.Nr.: 6111500160	Ref.Nr.: 5117591AA	Ref.Nr.: 2024100747	Ref.Nr.: 2013512742	Ref.Nr.: 2023300075	Ref.Nr.: 2024600319
<b>F8-5197</b>	<b>F8-6239</b>	<b>F8-6466</b>	<b>F8-6474</b>	<b>F8-6813</b>	<b>F8-6814</b>	<b>F8-6924</b>
Ref.Nr.: 1703300075	Ref.Nr.: 1704100015	Ref.Nr.: 210 325 03 84	Ref.Nr.: 202 330 01 75	Ref.Nr.: 2023337714	Ref.Nr.: 2023336214	Ref.Nr.: 2022400518
<b>F8-7747</b>	<b>F8-8178</b>	<b>G9-503</b>	<b>G9-651</b>	<b>G9-652</b>		
Ref.Nr.: 1402401218	Ref.Nr.: 2022400218	Ref.Nr.: 1243524365	Ref.Nr.: 1243529065	Ref.Nr.: 1243528665		

Article Description



Article Nr.

Fitting Position



C-CLASS Estate (S202)		06/1996 → 03/2001	
Suspension Kit	C 180 T, C 200 T, C 200 T D, C 200 T Kompressor, C 220 T D, C 230 T, C 230 T Kompressor, C 250 T Turbo-D	ch.F500866→	F8-5197
Suspension Kit	C 180 T, C 200 T Kompressor, C 220 T D, C 240 T	ch.A443813, F500866→	F8-5197
Suspension Kit	C 200 T CDI, C 220 T CDI, C 240 T, C 280 T, C 43 AMG		F8-5197
Stabiliser Mounting	C 180 T, C 200 T, C 200 T D, C 220 T D, C 230 T		F8-5214  d=18
Stabiliser Mounting	C 180 T, C 200 T, C 200 T D, C 200 T Kompressor, C 220 T CDI, C 220 T D, C 230 T, C 230 T Kompressor, C 240 T, C 250 T Turbo-D, C 280 T, C 43 AMG		F8-5217  d=26.5
Stabiliser Mounting	C 43 AMG	ch.F668976→	F8-5222  d=30
Stabiliser Mounting	C 180 T, C 200 T, C 200 T D, C 220 T D, C 230 T		F8-5227  d=23
Stabiliser Mounting	C 180 T, C 200 T, C 200 T D, C 220 T D, C 230 T	SP	F8-5236  H=38; d=24; D=45
Control Arm-/Trailing Arm Bush	All Models		F8-5297  H=48; d=14.1; D=40.03
Control Arm-/Trailing Arm Bush	C 180 T, C 200 T, C 200 T D, C 200 T Kompressor, C 220 T D, C 230 T, C 230 T Kompressor, C 250 T Turbo-D	ch.F500866→	F8-5307  H=43; d=20; D=70
Control Arm-/Trailing Arm Bush	C 180 T, C 200 T CDI, C 200 T Kompressor, C 220 T CDI, C 220 T D, C 240 T, C 280 T, C 43 AMG		F8-5307  H=43; d=20; D=70
Mounting, manual transmission	C 240 T, C 280 T		F8-5308  H=75; L=110
Control Arm-/Trailing Arm Bush	C 180 T, C 200 T, C 200 T CDI, C 200 T D, C 200 T Kompressor, C 220 T CDI, C 220 T D, C 230 T, C 230 T Kompressor, C 240 T, C 250 T Turbo-D, C 280 T, C 43 AMG		F8-5327  d=11; D=36
Engine Mounting	C 180 T, C 200 T	ch.→F483847	F8-5460
Engine Mounting	C 200 T CDI, C 200 T D, C 220 T CDI, C 220 T D, C 230 T, C 230 T Kompressor		F8-5460
Engine Mounting	C 180 T, C 200 T	ch.→F483847	F8-5461
Engine Mounting	C 200 T D, C 220 T CDI, C 220 T D		F8-5461
Control Arm-/Trailing Arm Bush	All Models		F8-5477
Belt Pulley, crankshaft	All Models	Parameter: 6PK	F8-5663  d=32; D1=160; D2=157; W1=82
Control Arm-/Trailing Arm Bush	All Models		F8-5678  H=58; d=12; D=33
Repair Set, axle beam	C 180 T, C 200 T, C 200 T CDI, C 200 T D, C 200 T Kompressor, C 220 T CDI, C 220 T D, C 230 T, C 230 T Kompressor, C 240 T, C 250 T Turbo-D, C 280 T, C 43 AMG	with fastening material; with accessories	F8-5697
Control Arm-/Trailing Arm Bush	C 180 T, C 200 T, C 200 T CDI, C 200 T D, C 200 T Kompressor, C 220 T CDI, C 220 T D, C 230 T, C 230 T Kompressor, C 240 T, C 250 T Turbo-D, C 280 T, C 43 AMG		F8-5698

<b>F8-5197</b>	<b>F8-5214</b>	<b>F8-5217</b>	<b>F8-5222</b>	<b>F8-5227</b>	<b>F8-5236</b>	<b>F8-5297</b>
Ref.Nr.: 1703300075	Ref.Nr.: 1243234985	Ref.Nr.: 1243235685	Ref.Nr.: 1293230185	Ref.Nr.: 2023230285	Ref.Nr.: 1243235485	Ref.Nr.: 2043520027
<b>F8-5307</b>	<b>F8-5308</b>	<b>F8-5327</b>	<b>F8-5460</b>	<b>F8-5461</b>	<b>F8-5477</b>	<b>F8-5663</b>
Ref.Nr.: 2023338714	Ref.Nr.: 2102400418	Ref.Nr.: 1243523565	Ref.Nr.: 2022401717	Ref.Nr.: 2102400617	Ref.Nr.: 2023336414	Ref.Nr.: 1120350800
<b>F8-5678</b>	<b>F8-5697</b>	<b>F8-5698</b>	<b>F8-6230</b>			
Ref.Nr.: 1293520065	Ref.Nr.: 1243506708	Ref.Nr.: 2023510842	Ref.Nr.: 1243516408			



Article Description



Article Nr.

Fitting Position



### C-CLASS Estate (S202) 06/1996 → 03/2001

Repair Set, axle beam	All Models	with fastening material	<b>F8-6230</b>		
Joint, propshaft	C 200 T CDI , C 200 T Kompressor , C 220 T CDI , C 230 T Kompressor , C 250 T Turbo-D	with fastening material	<b>F8-6239</b>		Bolt Hole Circle Ø [mm]=100; d=46; D=140; W=29.8
Joint, propshaft	C 250 T Turbo-D	with fastening material;	<b>F8-6239</b>		Bolt Hole Circle Ø [mm]=100; d=46; D=140; W=29.8
Rubber Buffer, suspension	All Models		<b>F8-6466</b>		
Suspension Kit	All Models	with fastening material	<b>F8-6474</b>		
Control Arm-/Trailing Arm Bush	All Models	<b>SP</b>	<b>F8-6813</b>		H=99; d=10; W=48
Control Arm-/Trailing Arm Bush	All Models	<b>SP</b>	<b>F8-6814</b>		
Engine Mounting	C 180 T , C 200 T , C 230 T , C 250 T Turbo-D	ch.→F675418; Aluminium;	<b>F8-7747</b>		L=104
Engine Mounting	C 240 T , C 280 T	ch.F980774→; ; Aluminium;	<b>F8-7747</b>		L=104
Mounting, manual transmission	C 180 T , C 200 T , C 200 T D , C 200 T Kompressor , C 220 T D , C 230 T , C 230 T Kompressor , C 250 T Turbo-D		<b>F8-8178</b>		
Control Arm-/Trailing Arm Bush	All Models		<b>G9-503</b>		H=43; d=12; D=31
Control Arm-/Trailing Arm Bush	All Models		<b>G9-651</b>		d=12
Control Arm-/Trailing Arm Bush	All Models		<b>G9-652</b>		d=13

### C-CLASS (W203) 05/2000 → 02/2007

Dust Cover Kit, shock absorber	C 180 , C 180 Kompressor , C 200 CDI, C 200 CGI Kompressor , C 200 Kompressor , C 220 CDI , C 230 , C 230 Kompressor , C 240 , C 270 CDI , C 280 , C 320 , C 320 CDI , C 350		<b>AK-735081</b>		
Dust Cover Kit, shock absorber	C 30 CDI AMG , C 32 AMG Kompressor , C 55 AMG		<b>AK-735226</b>		
Alternator Freewheel Clutch	C 200 CDI , C 220 CDI , C 270 CDI		<b>F5-1018</b>		
Alternator Freewheel Clutch	C 30 CDI AMG		<b>F5-1019</b>		
Alternator Freewheel Clutch	C 180 Kompressor , C 200 CGI Kompressor , C 200 Kompressor , C 230 Kompressor		<b>F5-1056</b>		
Alternator Freewheel Clutch	C 200 CDI , C 220 CDI		<b>F5-1058</b>		
Alternator Freewheel Clutch	C 320 CDI		<b>F5-1126</b>		
Control Arm-/Trailing Arm Bush	C 180 , C 200 CDI , C 200 Kompressor , C 220 CDI , C 240 , C 270 CDI , C 32 AMG Kompressor , C 320		<b>F8-5297</b>		H=48; d=14.1; D=40.03
Belt Pulley, crankshaft	C 240 , C 240 4-matic , C 32 AMG Kompressor , C 320 , C 320 4-matic	Parameter: 6PK	<b>F8-5663</b>		d=32; D1=160; D2=157; W1=82
Control Arm-/Trailing Arm Bush	C 180 , C 180 Kompressor , C 200 CDI , C 200 CGI Kompressor , C 200 Kompressor , C 220 CDI , C 240 , C 240 4-matic , C 270 CDI , C 30 CDI AMG , C 32 AMG Kompressor , C 320 , C 320 4-matic		<b>F8-5678</b>		H=58; d=12; D=33

<b>AK-735081</b>	<b>AK-735226</b>	<b>F5-1018</b>	<b>F5-1019</b>	<b>F5-1056</b>	<b>F5-1058</b>	<b>F5-1126</b>
Ref.Nr.: 2033200744	Ref.Nr.: 2033200844	Ref.Nr.: 6111500360	Ref.Nr.: 5117591AA	Ref.Nr.: 2711550016	Ref.Nr.: 6461500260	Ref.Nr.: 05175811AA
<b>F8-5297</b>	<b>F8-5663</b>	<b>F8-5678</b>	<b>F8-5872</b>	<b>F8-6230</b>	<b>F8-6239</b>	<b>F8-6466</b>
Ref.Nr.: 2043520027	Ref.Nr.: 1120350800	Ref.Nr.: 1293520065	Ref.Nr.: 5131.53	Ref.Nr.: 1243516408	Ref.Nr.: 1704100015	Ref.Nr.: 210 325 03 84
<b>F8-6474</b>	<b>F8-6813</b>	<b>F8-6814</b>	<b>F8-7747</b>	<b>F8-8178</b>	<b>G9-503</b>	<b>G9-651</b>
Ref.Nr.: 202 330 01 75	Ref.Nr.: 2023337714	Ref.Nr.: 2023336214	Ref.Nr.: 1402401218	Ref.Nr.: 2022400218	Ref.Nr.: 1243524365	Ref.Nr.: 1243529065

Article Description



Article Nr.

Fitting Position



C-CLASS (W203)		05/2000 → 02/2007		
Control Arm-/Trailing Arm Bush	C 180 , C 180 Kompressor , C 200 CDI , C 200 CGI Kompressor , C 200 Kompressor , C 220 CDI , C 240 , C 240 4-matic , C 270 CDI , C 30 CDI AMG , C 32 AMG Kompressor , C 320 , C 320 4-matic		<b>F8-5872</b>	H1=60; H2=40; d=12; D=40
Mounting, axle beam	C 180 , C 180 Kompressor , C 200 CDI , C 200 CGI Kompressor , C 200 Kompressor , C 220 CDI , C 230 Kompressor , C 240 , C 240 4-matic , C 270 CDI , C 30 CDI AMG , C 32 AMG Kompressor , C 320 , C 320 4-matic , C 320 CDI		<b>F8-5873</b>	H=29; d=15; D=66
Stabiliser Mounting	C 180 , C 180 Kompressor , C 200 CDI , C 200 Kompressor , C 220 CDI , C 230 Kompressor , C 240 , C 240 4-matic , C 270 CDI , C 320 , C 320 4-matic	<b>SP</b>	<b>F8-5980</b>	d=20
Stabiliser Mounting	C 200 CGI Kompressor		<b>F8-5980</b>	d=20
Repair Kit, suspension strut	C 180 , C 180 Kompressor , C 200 CDI , C 200 CGI Kompressor , C 200 Kompressor , C 220 CDI , C 230 , C 230 Kompressor , C 240 , C 270 CDI , C 280 , C 30 CDI AMG , C 32 AMG Kompressor , C 320 , C 320 CDI , C 350 , C 55 AMG		<b>F8-6539</b>	
Engine Mounting	C 240 , C 320		<b>F8-6647</b>	
Joint, propshaft	C 220 CDI , C 270 CDI , C 32 AMG Kompressor , C 320 CDI , C 350	with fastening material	<b>F8-6760</b>	d=57.5; D=145; Thick./Strength 1 [mm]=31.5
Joint, propshaft	C 200 Kompressor , C 240 , C 240 4-matic	with add-on material	<b>F8-6761</b>	d=50; D=133; Thick./Strength 1 [mm]=28.5
Engine Mounting	C 180 Kompressor , C 200 CGI Kompressor , C 200 Kompressor , C 230 Kompressor		<b>F8-6950</b>	
Engine Mounting	C 180 Kompressor , C 200 CGI Kompressor , C 200 Kompressor , C 230 Kompressor		<b>F8-6951</b>	
Engine Mounting	C 180 Kompressor , C 200 CGI Kompressor , C 200 Kompressor , C 230 Kompressor	Aluminium	<b>F8-7747</b>	L=104
Engine Mounting	C 200 CDI , C 220 CDI , C 270 CDI , C 30 CDI AMG	Aluminium; not for  5-speed	<b>F8-7747</b>	L=104
Engine Mounting	C 320 CDI	Aluminium; not for  6-speed, not for  7-speed	<b>F8-7747</b>	L=104
Mounting, steering gear	C 180 , C 180 Kompressor , C 200 CDI , C 200 CGI Kompressor , C 200 Kompressor , C 220 CDI , C 230 , C 230 Kompressor , C 240 , C 270 CDI , C 280 , C 30 CDI AMG , C 32 AMG Kompressor , C 320 , C 320 CDI , C 350 , C 55 AMG		<b>F8-7932</b>	
Engine Mounting	C 230 , C 280 , C 350		<b>F8-8153</b>	
Engine Mounting	C 220 CDI , C 270 CDI		<b>F8-8175</b>	
Control Arm-/Trailing Arm Bush	C 180 , C 180 Kompressor , C 200 CDI , C 200 CGI Kompressor , C 200 Kompressor , C 220 CDI , C 230 Kompressor , C 240 , C 240 4-matic , C 270 CDI , C 30 CDI AMG , C 32 AMG Kompressor , C 320 , C 320 4-matic , C 320 CDI , C 55 AMG		<b>G9-503</b>	H=43; d=12; D=31

<b>F8-5872</b>	<b>F8-5873</b>	<b>F8-5980</b>	<b>F8-6539</b>	<b>F8-6647</b>	<b>F8-6760</b>	<b>F8-6761</b>
Ref.Nr.: 5131.53	Ref.Nr.: 1293512142	Ref.Nr.: 2033230685	Ref.Nr.: 203 320 02 73	Ref.Nr.: 203 240 12 17	Ref.Nr.: 0004110200	Ref.Nr.: 2034100315
<b>F8-6950</b>	<b>F8-6951</b>	<b>F8-7747</b>	<b>F8-7932</b>	<b>F8-8153</b>	<b>F8-8175</b>	<b>G9-503</b>
Ref.Nr.: 2032401917	Ref.Nr.: 2032402017	Ref.Nr.: 1402401218	Ref.Nr.: 2033330514	Ref.Nr.: 2112403017	Ref.Nr.: 2112400317	Ref.Nr.: 1243524365
<b>G9-651</b>						
Ref.Nr.: 1243529065						



Article Description



Article Nr.

Fitting Position



<b>C-CLASS (W203)</b>		<b>05/2000 → 02/2007</b>	
Control Arm-/Trailing Arm Bush	C 180 , C 180 Kompressor , C 200 CDI , C 200 CGI Kompressor , C 200 Kompressor , C 220 CDI , C 230 Kompressor , C 240 , C 240 4-matic , C 270 CDI , C 30 CDI AMG , C 32 AMG Kompressor , C 320 , C 320 4-matic , C 320 CDI , C 55 AMG	<b>G9-651</b>	d=12
Control Arm-/Trailing Arm Bush	C 180 , C 180 Kompressor , C 200 CDI , C 200 CGI Kompressor , C 200 Kompressor , C 220 CDI , C 230 Kompressor , C 240 , C 240 4-matic , C 270 CDI , C 30 CDI AMG , C 32 AMG Kompressor , C 320 , C 320 4-matic , C 320 CDI , C 55 AMG	<b>G9-652</b>	d=13
<b>C-CLASS Coupe (CL203)</b>		<b>03/2001 → 05/2008</b>	
Dust Cover Kit, shock absorber	C 160 Kompressor , C 180 , C 180 Kompressor , C 200 CDI , C 200 CGI Kompressor , C 200 Kompressor , C 220 CDI , C 230 , C 230 Kompressor , C 320 , C 350	<b>AK-735081</b>	
Dust Cover Kit, shock absorber	C 30 CDI AMG , C 32 AMG Kompressor	<b>AK-735226</b>	
Alternator Freewheel Clutch	C 220 CDI	<b>F5-1018</b>	
Alternator Freewheel Clutch	C 30 CDI AMG	<b>F5-1019</b>	
Alternator Freewheel Clutch	C 160 Kompressor , C 180 Kompressor , C 200 CGI Kompressor , C 200 Kompressor , C 230 Kompressor	<b>F5-1056</b>	
Alternator Freewheel Clutch	C 200 CDI , C 220 CDI	<b>F5-1058</b>	
Control Arm-/Trailing Arm Bush	C 180 , C 200 Kompressor , C 220 CDI , C 230 Kompressor	<b>F8-5297</b>	H=48; d=14.1; D=40.03
Belt Pulley, crankshaft	C 320	Parameter: 6PK	<b>F8-5663</b>
Control Arm-/Trailing Arm Bush	C 180 , C 200 CDI , C 200 CGI Kompressor , C 200 Kompressor , C 220 CDI , C 230 Kompressor , C 30 CDI AMG , C 320	<b>F8-5678</b>	H=58; d=12; D=33
Control Arm-/Trailing Arm Bush	C 180 , C 180 Kompressor , C 200 CDI , C 200 CGI Kompressor , C 200 Kompressor , C 220 , C 220 CDI , C 230 Kompressor , C 30 CDI AMG , C 320	<b>F8-5872</b>	H1=60; H2=40; d=12; D=40
Mounting, axle beam	C 180 , C 180 Kompressor , C 200 CDI , C 200 CGI Kompressor , C 200 Kompressor , C 220 , C 220 CDI , C 230 Kompressor , C 30 CDI AMG , C 32 AMG Kompressor , C 320	<b>F8-5873</b>	H=29; d=15; D=66
Stabiliser Mounting	C 180 , C 180 Kompressor , C 200 CGI Kompressor , C 200 Kompressor , C 220 CDI , C 230 Kompressor , C 320	<b>F8-5980</b>	d=20
Stabiliser Mounting	C 220 , C 230 Kompressor , C 30 CDI AMG	<b>F8-5980</b>	d=20
Repair Kit, suspension strut	C 160 Kompressor , C 180 , C 180 Kompressor , C 200 CDI , C 200 CGI Kompressor , C 200 Kompressor , C 220 , C 220 CDI , C 230 , C 230 Kompressor , C 30 CDI AMG , C 32 AMG Kompressor , C 320 , C 350	<b>F8-6539</b>	
Engine Mounting	C 320	<b>F8-6647</b>	
Joint, propshaft	C 220 CDI , C 350	with fastening material	<b>F8-6760</b>
			d=57.5; D=145; Thick./Strength 1 [mm]=31.5

<b>AK-735081</b>	<b>AK-735226</b>	<b>F5-1018</b>	<b>F5-1019</b>	<b>F5-1056</b>	<b>F5-1058</b>	<b>F8-5297</b>
Ref.Nr.: 2033200744	Ref.Nr.: 2033200844	Ref.Nr.: 6111500360	Ref.Nr.: 5117591AA	Ref.Nr.: 2711550016	Ref.Nr.: 6461500260	Ref.Nr.: 2043520027
<b>F8-5663</b>	<b>F8-5678</b>	<b>F8-5872</b>	<b>F8-5873</b>	<b>F8-5980</b>	<b>F8-6539</b>	<b>F8-6647</b>
Ref.Nr.: 1120350800	Ref.Nr.: 1293520065	Ref.Nr.: 5131.53	Ref.Nr.: 1293512142	Ref.Nr.: 2033230685	Ref.Nr.: 203 320 02 73	Ref.Nr.: 203 240 12 17
<b>F8-6760</b>	<b>F8-6761</b>	<b>G9-651</b>	<b>G9-652</b>			
Ref.Nr.: 0004110200	Ref.Nr.: 2034100315	Ref.Nr.: 1243529065	Ref.Nr.: 1243528665			

Article Description

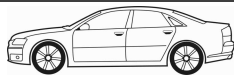

Article Nr.

Fitting Position



<b>C-CLASS Coupe (CL203)</b>		<b>03/2001 → 05/2008</b>	
Joint, propshaft	C 180 Kompressor , C 200 Kompressor , C 220, C 230 Kompressor	with add-on material	<b>F8-6761</b>
Engine Mounting	C 180 Kompressor , C 200 CGI Kompressor , C 200 Kompressor , C 230 Kompressor		<b>F8-6950</b> ⊕
Engine Mounting	C 180 Kompressor , C 200 CGI Kompressor , C 200 Kompressor , C 230 Kompressor		<b>F8-6951</b> ⊕
Engine Mounting	C 160 Kompressor , C 180 Kompressor , C 200 CGI Kompressor , C 200 Kompressor , C 230 Kompressor	Aluminium	<b>F8-7747</b>
Engine Mounting	C 200 CDI , C 220 CDI , C 30 CDI AMG	Aluminium; not for 5-speed	<b>F8-7747</b>
Mounting, steering gear	C 160 Kompressor , C 180 , C 180 Kompressor , C 200 CDI , C 200 CGI Kompressor , C 200 Kompressor , C 220 CDI , C 230 , C 230 Kompressor , C 30 CDI AMG , C 320 , C 350		<b>F8-7932</b> ⊕ ⊕
Engine Mounting	C 230 , C 350		<b>F8-8153</b>
Engine Mounting	C 220 CDI		<b>F8-8175</b> ⊕
Control Arm-/Trailing Arm Bush	C 180 , C 180 Kompressor , C 200 CDI , C 200 CGI Kompressor , C 200 Kompressor , C 220 CDI , C 230 Kompressor , C 30 CDI AMG , C 320		<b>G9-503</b> ⊕ ⊕
Control Arm-/Trailing Arm Bush	C 180 , C 180 Kompressor , C 200 CDI , C 200 CGI Kompressor , C 200 Kompressor , C 220 CDI , C 230 Kompressor , C 30 CDI AMG , C 320		<b>G9-651</b> ⊕ ⊕
Control Arm-/Trailing Arm Bush	C 180 , C 180 Kompressor , C 200 CDI , C 200 CGI Kompressor , C 200 Kompressor , C 220 CDI , C 230 Kompressor , C 30 CDI AMG , C 320		<b>G9-652</b> ⊕ ⊕
Bellow, steering	C 200 CDI	with clamps	<b>LM-10082S</b> ⊕
<b>C-CLASS T-Model (S203)</b>		<b>03/2001 → 08/2007</b>	
Dust Cover Kit, shock absorber	C 180 , C 180 Kompressor , C 200 CDI , C 200 CGI Kompressor , C 200 Kompressor , C 220 CDI , C 230 , C 230 Kompressor , C 240 , C 270 CDI , C 280 , C 320 , C 320 CDI , C 350		<b>AK-735081</b> ⊕ ⊕
Dust Cover Kit, shock absorber	C 30 CDI AMG , C 32 AMG Kompressor , C 55 AMG		<b>AK-735226</b> ⊕ ⊕
Alternator Freewheel Clutch	C 200 CDI , C 220 CDI , C 270 CDI		<b>F5-1018</b>
Alternator Freewheel Clutch	C 30 CDI AMG		<b>F5-1019</b>
Alternator Freewheel Clutch	C 180 Kompressor , C 200 CGI Kompressor , C 200 Kompressor , C 230 Kompressor		<b>F5-1056</b>
Alternator Freewheel Clutch	C 200 CDI , C 220 CDI		<b>F5-1058</b>
Alternator Freewheel Clutch	C 320 CDI		<b>F5-1126</b>
Control Arm-/Trailing Arm Bush	C 200 CDI , C 200 Kompressor , C 220 CDI , C 270 CDI , C 320		<b>F8-5297</b> ⊕ ⊕ ⊕
Belt Pulley, crankshaft	C 240 , C 240 4-matic , C 32 AMG Kompressor , C 320 , C 320 4-matic	Parameter: 6PK	<b>F8-5663</b>

<b>AK-735081</b>	<b>AK-735226</b>	<b>F5-1018</b>	<b>F5-1019</b>	<b>F5-1056</b>	<b>F5-1058</b>	<b>F5-1126</b>
Ref.Nr.: 2033200744	Ref.Nr.: 2033200844	Ref.Nr.: 6111500360	Ref.Nr.: 5117591AA	Ref.Nr.: 2711550016	Ref.Nr.: 6461500260	Ref.Nr.: 05175811AA
<b>F8-5297</b>	<b>F8-5663</b>	<b>F8-5678</b>	<b>F8-6761</b>	<b>F8-6950</b>	<b>F8-6951</b>	<b>F8-7747</b>
Ref.Nr.: 2043520027	Ref.Nr.: 1120350800	Ref.Nr.: 1293520065	Ref.Nr.: 2034100315	Ref.Nr.: 2032401917	Ref.Nr.: 2032402017	Ref.Nr.: 1402401218
<b>F8-7932</b>	<b>F8-8153</b>	<b>F8-8175</b>	<b>G9-503</b>	<b>G9-651</b>	<b>G9-652</b>	<b>LM-10082S</b>
Ref.Nr.: 2033330514	Ref.Nr.: 2112403017	Ref.Nr.: 2112400317	Ref.Nr.: 1243524365	Ref.Nr.: 1243529065	Ref.Nr.: 1243528665	Ref.Nr.: 1714630096





Article Description



Article Nr.

Fitting Position



C-CLASS T-Model (S203)		03/2001 → 08/2007		
Control Arm-/Trailing Arm Bush	C 180 , C 180 Kompressor , C 200 CDI , C 200 CGI Kompressor , C 200 Kompressor , C 220 CDI , C 240 , C 240 4-matic , C 270 CDI , C 30 CDI AMG , C 32 AMG Kompressor , C 320 , C 320 4-matic	F8-5678	⊕ ⊕	H=58; d=12; D=33
Control Arm-/Trailing Arm Bush	C 180 , C 180 Kompressor , C 200 CDI , C 200 CGI Kompressor , C 200 Kompressor , C 220 CDI , C 240 , C 240 4-matic , C 270 CDI , C 30 CDI AMG , C 32 AMG Kompressor , C 320 , C 320 4-matic	F8-5872	⊕ ⊕	H1=60; H2=40; d=12; D=40
Mounting, axle beam	C 180 , C 180 Kompressor , C 200 CDI , C 200 CGI Kompressor , C 200 Kompressor , C 220 CDI , C 230 Kompressor , C 240 , C 240 4-matic , C 270 CDI , C 30 CDI AMG , C 32 AMG Kompressor , C 320 , C 320 4-matic , C 55 AMG	F8-5873	⊕ ⊕	H=29; d=15; D=66
Stabiliser Mounting	C 180	F8-5980	⊕ ⊕	d=20
Stabiliser Mounting	C 180 Kompressor , C 200 CGI Kompressor , C 200 Kompressor	F8-5980	⊕ ⊕	d=20
Repair Kit, suspension strut	C 180 , C 180 Kompressor , C 200 CDI , C 200 CGI Kompressor , C 200 Kompressor , C 220 CDI , C 230 , C 230 Kompressor , C 240 , C 240 4-matic , C 270 CDI , C 280 , C 30 CDI AMG , C 32 AMG Kompressor , C 320 , C 320 4-matic , C 320 CDI , C 350 , C 55 AMG	F8-6539	⊕ ⊕	
Engine Mounting	C 240 , C 320	F8-6647	⊕ ⊕	
Joint, propshaft	C 220 CDI , C 270 CDI , C 32 AMG Kompressor , C 320 CDI , C 350	with fastening material F8-6760		d=57.5; D=145; Thick./Strength 1 [mm]=31.5
Joint, propshaft	C 200 CGI Kompressor , C 200 Kompressor , C 240 , C 240 4-matic	with add-on material F8-6761		d=50; D=133; Thick./Strength 1 [mm]=28.5
Engine Mounting	C 180 Kompressor , C 200 CGI Kompressor , C 200 Kompressor , C 230 Kompressor	F8-6950	⊕	
Engine Mounting	C 180 Kompressor , C 200 CGI Kompressor , C 200 Kompressor , C 230 Kompressor	F8-6951	⊕	
Engine Mounting	C 180 Kompressor , C 200 CGI Kompressor , C 200 Kompressor , C 230 Kompressor	Aluminium F8-7747		L=104
Engine Mounting	C 200 CDI , C 220 CDI , C 270 CDI , C 30 CDI AMG	Aluminium; not for  5-speed F8-7747		L=104
Engine Mounting	C 320 CDI	Aluminium; not for  6-speed, not for  7-speed F8-7747		L=104
Mounting, steering gear	C 180 , C 180 Kompressor , C 200 CDI , C 200 CGI Kompressor , C 200 Kompressor , C 220 CDI , C 230 , C 230 Kompressor , C 240 , C 270 CDI , C 280 , C 30 CDI AMG , C 32 AMG Kompressor , C 320 , C 320 CDI , C 350 , C 55 AMG	F8-7932	⊕ ⊕	
Engine Mounting	C 230 , C 280 , C 350	F8-8153		
Engine Mounting	C 220 CDI , C 270 CDI	F8-8175	⊕	

<b>F8-5678</b>	<b>F8-5872</b>	<b>F8-5873</b>	<b>F8-5980</b>	<b>F8-6539</b>	<b>F8-6647</b>	<b>F8-6760</b>
Ref.Nr.: 1293520065	Ref.Nr.: 5131.53	Ref.Nr.: 1293512142	Ref.Nr.: 2033230685	Ref.Nr.: 203 320 02 73	Ref.Nr.: 203 240 12 17	Ref.Nr.: 0004110200
<b>F8-6761</b>	<b>F8-6950</b>	<b>F8-6951</b>	<b>F8-7747</b>	<b>F8-7932</b>	<b>F8-8153</b>	<b>F8-8175</b>
Ref.Nr.: 2034100315	Ref.Nr.: 2032401917	Ref.Nr.: 2032402017	Ref.Nr.: 1402401218	Ref.Nr.: 203330514	Ref.Nr.: 2112403017	Ref.Nr.: 2112400317
<b>G9-503</b>						
Ref.Nr.: 1243524365						

Article Description			Article Nr.	Fitting Position	
---------------------	--	--	-------------	------------------	--

<b>C-CLASS T-Model (S203)</b>		<b>03/2001 → 08/2007</b>			
Control Arm-/Trailing Arm Bush	C 180 , C 180 Kompressor , C 200 CDI , C 200 CGI Kompressor , C 200 Kompressor , C 220 CDI , C 230 Kompressor , C 240 , C 240 4-matic , C 270 CDI , C 30 CDI AMG , C 32 AMG Kompressor , C 320 , C 320 4-matic , C 55 AMG	<b>G9-503</b>	⊕ ⊕		H=43; d=12; D=31
Control Arm-/Trailing Arm Bush	C 180 , C 180 Kompressor , C 200 CDI , C 200 CGI Kompressor , C 200 Kompressor , C 220 CDI , C 230 Kompressor , C 240 , C 240 4-matic , C 270 CDI , C 30 CDI AMG , C 32 AMG Kompressor , C 320 , C 320 4-matic , C 55 AMG	<b>G9-651</b>	⊕ ⊕		d=12
Control Arm-/Trailing Arm Bush	C 180 , C 180 Kompressor , C 200 CDI , C 200 CGI Kompressor , C 200 Kompressor , C 220 CDI , C 230 Kompressor , C 240 , C 240 4-matic , C 270 CDI , C 30 CDI AMG , C 32 AMG Kompressor , C 320 , C 320 4-matic , C 55 AMG	<b>G9-652</b>	⊕ ⊕		d=13
<b>C-CLASS (W204)</b>		<b>01/2007 → 01/2014</b>			
Dust Cover Kit, shock absorber	C 180 CGI , C 180 Kompressor , C 200 CDI , C 200 CGI , C 200 Kompressor , C 220 CDI , C 230 , C 230 4-matic , C 250 CDI , C 250 CGI , C 280 , C 280 4-matic , C 320 CDI , C 320 CDI 4-matic , C 350 , C 350 4-matic , C 350 CDI , C 350 CGI	<b>AK-735223</b>	⊕ ⊕		
Dust Cover Kit, shock absorber	C 180 CGI , C 180 Kompressor , C 200 CDI , C 200 CGI , C 200 Kompressor , C 220 CDI , C 230 , C 230 4-matic , C 250 CDI , C 250 CGI , C 280 , C 280 4-matic , C 320 CDI , C 320 CDI 4-matic , C 350 , C 350 4-matic , C 350 CDI , C 350 CDI 4-matic , C 350 CGI	<b>AK-735224</b>	⊕ ⊕		
Alternator Freewheel Clutch	C 200 CDI , C 220 CDI	<b>F5-1058</b>			
Alternator Freewheel Clutch	C 300 CDI 4-matic , C 320 CDI , C 320 CDI 4-matic , C 350 CDI , C 350 CDI 4-matic	<b>F5-1126</b>			
Control Arm-/Trailing Arm Bush	C 180 Kompressor , C 200 CDI , C 200 Kompressor , C 220 CDI , C 230 , C 230 4-matic , C 250 CDI , C 280 , C 300 4-matic , C 320 CDI , C 320 CDI 4-matic , C 350 , C 350 4-matic , C 350 CGI , C 63 AMG	<b>F8-6145</b>	⊕ ⊕		d=12.2
Mounting, axle beam	C 180 Kompressor , C 200 CDI , C 200 Kompressor , C 220 CDI , C 230 , C 230 4-matic , C 250 CDI , C 280 , C 280 4-matic , C 300 4-matic , C 320 CDI , C 320 CDI 4-matic , C 350 , C 350 4-matic , C 350 CGI , C 63 AMG	<b>F8-6648</b>	⊕ ⊕		
Joint, propshaft	C 220 CDI , C 350	with fastening material		<b>F8-6760</b>	d=57.5; D=145; Thick./Strength 1 [mm]=31.5
Top Strut Mounting	C 180 CDI , C 180 CGI , C 180 Kompressor , C 200 , C 200 CDI , C 200 CGI , C 200 Kompressor , C 220 CDI , C 220 CDI 4-matic , C 230 , C 230 4-matic , C 250 CDI , C 250 CDI 4-matic , C 250 CGI , C 280 , C 280 4-matic , C 300 , C 300 4-matic , C 300 CDI 4-matic	<b>F8-7477</b>	⊕ ⊕		

<b>AK-735223</b>	<b>AK-735224</b>	<b>F5-1058</b>	<b>F5-1126</b>	<b>F8-6145</b>	<b>F8-6648</b>	<b>F8-6760</b>
Ref.Nr.: A-2043230044	Ref.Nr.: A-2043260098	Ref.Nr.: 6461500260	Ref.Nr.: 05175811AA	Ref.Nr.: 2303521565	Ref.Nr.: 2043521065	Ref.Nr.: 0004110200
<b>F8-7477</b>	<b>F8-7478</b>	<b>G9-503</b>	<b>G9-651</b>	<b>G9-652</b>		
Ref.Nr.: 2043201273	Ref.Nr.: 2043200073	Ref.Nr.: 1243524365	Ref.Nr.: 1243529065	Ref.Nr.: 1243528665		

**Article Description****Article Nr.****Fitting Position****C-CLASS (W204)** 01/2007 → 01/2014

Top Strut Mounting	C 180 CDI , C 180 CGI , C 180 Kompressor , C 200, C 200 CDI , C 200 CGI , C 200 Kompressor , C 220 CDI , C 220 CDI 4-matic , C 230 , C 230 4-matic , C 250 CDI , C 250 CDI 4-matic , C 250 CGI , C 280 , C 280 4-matic , C 300 , C 300 4-matic , C 300 CDI 4-matic		<b>F8-7478</b>		
Top Strut Mounting	C 180 CDI , C 180 CGI , C 180 Kompressor , C 200, C 200 CDI , C 200 CGI , C 200 Kompressor , C 220 CDI , C 230 , C 230 4-matic , C 250 CDI , C 250 CDI 4-matic , C 250 CGI , C 280 , C 280 4-matic , C 300 , C 300 4-matic , C 320 CDI , C 320 CDI 4-matic , C		<b>F8-7626</b>		
Anti-Friction Bearing	C 180 CDI , C 180 CGI , C 180 Kompressor , C 200 CDI , C 200 CGI , C 200 Kompressor , C 220 CDI , C 230 , C 230 4-matic , C 250 CDI , C 250 CDI 4-matic , C 250 CGI , C 280 , C 280 4-matic , C 300 , C 300 4-matic , C 320 CDI , C 320 CDI 4-matic , C 350 , C		<b>F8-7631</b>		
Control Arm-/Trailing Arm Bush	C 180 CGI , C 180 Kompressor , C 200 CDI , C 200 CGI , C 200 Kompressor , C 220 CDI , C 230 , C 250 CDI , C 250 CGI , C 280 , C 300 , C 320 CDI , C 350 , C 350 CGI , C 350 AMG	Aluminium	<b>F8-7671</b>		
Control Arm-/Trailing Arm Bush	C 180 CDI , C 180 CGI , C 180 Kompressor , C 200 CDI , C 200 CGI , C 200 Kompressor , C 220 CDI , C 230 , C 230 4-matic , C 250 CDI , C 250 CDI 4-matic , C 250 CGI , C 280 , C 280 4-matic , C 300 , C 300 4-matic , C 300 CDI 4-matic , C 320 CDI	Shape Round; without cap	<b>F8-7858</b>		H1=80; H2=61; d=15; D=70.2
Protective Cap/Bellow, shock absorber	All Models	for vehicles without electronic drive dynamics regulation	<b>F8-7899</b>		H=224
Rubber Buffer, suspension	C 180 CDI , C 180 CGI , C 180 Kompressor , C 200, C 200 CDI , C 200 CGI , C 200 Kompressor , C 220 CDI , C 230 , C 250 CDI , C 250 CGI , C 280 , C 300 , C 320 CDI , C 350 , C 350 CDI , C 350 CGI	for vehicles without electronic drive dynamics regulation;	<b>F8-8079</b>		H=93; D=58
Rubber Buffer, suspension	C 200 CDI	for vehicles without electronic drive dynamics regulation;  OM 646.811;	<b>F8-8079</b>		H=93; D=58
Bellow, driveshaft	C 300 4-matic, C 350 4-matic		<b>M-871000</b>		
Bellow Set, drive shaft	C 300 4-matic, C 350 4-matic		<b>MK-871000</b>		

**C-CLASS Coupe (C204)** 06/2011 →

Top Strut Mounting	C 180 , C 200 CGI , C 220 CDI , C 250 , C 250 CDI , C 350		<b>F8-7477</b>		
Top Strut Mounting	C 180 , C 200 CGI , C 220 CDI , C 250 , C 250 CDI , C 350		<b>F8-7478</b>		
Top Strut Mounting	C 180 , C 220 CDI , C 250 , C 250 CDI , C 350 , C 63 AMG		<b>F8-7626</b>		
Control Arm-/Trailing Arm Bush	C 180 , C 220 CDI	Shape Round; without cap	<b>F8-7858</b>		H1=80; H2=61; d=15; D=70.2
Protective Cap/Bellow, shock absorber	C 180 , C 200 CGI , C 220 CDI , C 250 , C 250 CDI , C 350 , C 63 AMG	for vehicles without electronic drive dynamics regulation	<b>F8-7899</b>		H=224

<b>F8-7477</b>	<b>F8-7478</b>	<b>F8-7626</b>	<b>F8-7631</b>	<b>F8-7671</b>	<b>F8-7858</b>	<b>F8-7899</b>
Ref.Nr.: 2043201273	Ref.Nr.: 2043200073	Ref.Nr.: A2043260664	Ref.Nr.: 2049810025	Ref.Nr.: 2043306811	Ref.Nr.: 2033331014	Ref.Nr.: 2123230392
<b>F8-8079</b>	<b>M-871000</b>	<b>MK-871000</b>				
Ref.Nr.: A204 323 00 44	Ref.Nr.: 2213300285	Ref.Nr.: A2213300285				

Article Description



Article Nr.

Fitting Position



C-CLASS Coupe (C204)		06/2011 →	
Rubber Buffer, suspension	C 180 , C 220 CDI , C 250 , C 250 CDI , C 350	for vehicles without electronic drive dynamics regulation;	F8-8079
H=93; D=58			
C-CLASS T-Model (S204)		08/2007 → 08/2014	
Dust Cover Kit, shock absorber	C 180 Kompressor , C 200 CDI , C 200 Kompressor , C 220 CDI , C 230 , C 280 , C 320 CDI , C 350 , C 350 CDI		AK-735223
Dust Cover Kit, shock absorber	C 180 Kompressor , C 200 CDI , C 200 Kompressor , C 220 CDI , C 230 , C 280 , C 320 CDI , C 320 CDI 4-matic , C 350 , C 350 CDI , C 350 CDI 4-matic , C 63 AMG		AK-735224
Alternator Freewheel Clutch	C 250 CDI		F5-1017
Alternator Freewheel Clutch	C 250 CDI		F5-1019
Alternator Freewheel Clutch	C 200 CDI , C 220 CDI		F5-1058
Alternator Freewheel Clutch	C 320 CDI , C 320 CDI 4-matic , C 350 CDI , C 350 CDI 4-matic		F5-1126
Control Arm-/Trailing Arm Bush	C 180 Kompressor , C 200 CDI , C 200 Kompressor , C 220 CDI , C 230 , C 280 , C 320 CDI , C 320 CDI 4-matic , C 350 , C 63 AMG		F8-6145    d=12.2
Mounting, axle beam	C 180 Kompressor , C 200 CDI , C 200 Kompressor , C 220 CDI , C 230 , C 280 , C 320 CDI , C 320 CDI 4-matic , C 350 , C 63 AMG		F8-6648
Top Strut Mounting	C 180 CDI , C 180 CGI , C 180 Kompressor , C 200 CDI , C 200 CGI , C 200 Kompressor , C 220 CDI , C 220 CDI 4-matic , C 230 , C 250 CDI , C 250 CDI 4-matic , C 250 CGI , C 280 , C 320 CDI , C 320 CDI 4-matic , C 350 , C 350 CDI , C 350 CDI 4-matic , C 350	;	F8-7477
Top Strut Mounting	C 180 CDI , C 180 CGI , C 180 Kompressor , C 200 CDI , C 200 CGI , C 200 Kompressor , C 220 CDI , C 220 CDI 4-matic , C 230 , C 250 CDI , C 250 CDI 4-matic , C 250 CGI , C 280 , C 320 CDI , C 320 CDI 4-matic , C 350 , C 350 CDI , C 350 CDI 4-matic , C 350	;	F8-7478
Top Strut Mounting	C 180 CDI , C 180 CGI , C 180 Kompressor , C 200 CDI , C 200 CGI , C 200 Kompressor , C 220 CDI , C 230 , C 250 CDI , C 250 CDI 4-matic , C 250 CGI , C 280 , C 300 , C 320 CDI , C 320 CDI 4-matic , C 350 , C 350 CDI , C 350 CDI 4-matic , C 350 CGI , C 63 A		F8-7626
Anti-Friction Bearing	C 180 Kompressor , C 200 CDI , C 200 Kompressor , C 220 CDI , C 230 , C 250 CGI , C 280 , C 320 CDI , C 320 CDI 4-matic , C 350 , C 350 CDI , C 350 CDI 4-matic , C 63 AMG		F8-7631
Control Arm-/Trailing Arm Bush	C 180 CGI , C 180 Kompressor , C 200 CDI , C 200 Kompressor , C 220 CDI , C 230 , C 250 CDI , C 250 CGI , C 280 , C 320 CDI , C 350 , C 350 CDI , C 63 AMG	Aluminium	F8-7671

AK-735223	AK-735224	F5-1017	F5-1019	F5-1058	F5-1126	F8-6145
Ref.Nr.: A-2043230044	Ref.Nr.: A-2043260098	Ref.Nr.: 6111500160	Ref.Nr.: 5117591AA	Ref.Nr.: 6461500260	Ref.Nr.: 05175811AA	Ref.Nr.: 2303521565
F8-6648	F8-7477	F8-7478	F8-7626	F8-7631	F8-7671	F8-7858
Ref.Nr.: 2043521065	Ref.Nr.: 2043201273	Ref.Nr.: 2043200073	Ref.Nr.: A2043260664	Ref.Nr.: 2049810025	Ref.Nr.: 2043306811	Ref.Nr.: 2033331014
F8-8079						
Ref.Nr.: A204 323 00 44						

**Article Description****Article Nr.****Fitting Position****C-CLASS T-Model (S204) 08/2007 → 08/2014**

Control Arm-/Trailing Arm Bush	C 180 CGI , C 180 Kompressor , C 200 CDI , C 200 Kompressor , C 220 CDI , C 230 , C 250 CDI , C 250 CDI 4-matic , C 250 CGI , C 280 , C 300 , C 320 CDI , C 320 CDI 4-matic , C 350 , C 350 CDI , C 350 CDI 4-matic , C 63 AMG	Shape Round; without cap	<b>F8-7858</b>		H1=80; H2=61; d=15; D=70.2
Protective Cap/Bellow, shock absorber	C 180 CDI , C 180 CGI , C 180 Kompressor , C 200 CDI , C 200 CGI , C 200 Kompressor , C 220 CDI , C 220 CDI 4-matic , C 230 , C 250 CDI , C 250 CDI 4-matic , C 250 CGI , C 280 , C 300 , C 320 CDI , C 320 CDI 4-matic , C 350 , C 350 CDI , C 350 CDI 4-matic ,	for vehicles without electronic drive dynamics regulation	<b>F8-7899</b>		H=224
Rubber Buffer, suspension	C 180 CDI , C 180 CGI , C 180 Kompressor , C 200 CDI , C 200 CGI , C 200 Kompressor , C 220 CDI , C 230 , C 250 CDI , C 250 CGI , C 280 , C 300 , C 320 CDI , C 350 , C 350 CDI	for vehicles without electronic drive dynamics regulation;	<b>F8-8079</b>		H=93; D=58
Rubber Buffer, suspension	C 220 CDI	for vehicles without electronic drive dynamics regulation;  OM 651.911;	<b>F8-8079</b>		H=93; D=58
Rubber Buffer, suspension	C 350 CGI	for vehicles without electronic drive dynamics regulation;  M 276.957;	<b>F8-8079</b>		H=93; D=58

**C-CLASS (W205) 12/2013 →**

Alternator Freewheel Clutch	C 180 BlueTEC, C 200 BlueTEC		<b>F5-1126</b>		
Protective Cap/Bellow, shock absorber	C 200, C 220 BlueTEC	for vehicles without electronic drive dynamics regulation	<b>F8-7899</b>		H=224

**CLA Coupe (C117) 01/2013 →**

Protective Cap/Bellow, shock absorber	3.0, CLA 180, CLA 200, CLA 200 CDI, CLA 220 CDI, CLA 250, CLA 250 4-matic, CLA 45 AMG 4-matic	for vehicles without electronic drive dynamics regulation	<b>F8-7899</b>		H=224
---------------------------------------	---	---	----------------	--	-------

**CLC-CLASS (CL203) 05/2008 → 06/2011**

Alternator Freewheel Clutch	CLC 180 Kompressor		<b>F5-1056</b>		
Alternator Freewheel Clutch	CLC 200 CDI , CLC 220 CDI		<b>F5-1058</b>		
Repair Kit, suspension strut	All Models		<b>F8-6539</b>		
Engine Mounting	CLC 160 , CLC 180 Kompressor , CLC 200 Kompressor	Aluminium	<b>F8-7747</b>		L=104
Engine Mounting	CLC 200 CDI , CLC 220 CDI	Aluminium; not for  5-speed	<b>F8-7747</b>		L=104
Engine Mounting	CLC 230 , CLC 350		<b>F8-8153</b>		
Bellow, steering	CLC 200 CDI	with clamps	<b>LM-10082S</b>		d1=14; d2=63; L [mm]=225

**CLK (C208) 06/1997 → 06/2002**

Stabiliser Mounting	200, 200 Kompressor , 230 Kompressor , 320		<b>F8-5217</b>		d=26.5
Stabiliser Mounting	200		<b>F8-5227</b>		d=23
Stabiliser Mounting	200	M 111.945	<b>F8-5236</b>		H=38; d=24; D=45
Control Arm-/Trailing Arm Bush	200, 200 Kompressor , 230 Kompressor , 320, 430, 55 AMG		<b>F8-5307</b>		H=43; d=20; D=70

<b>F5-1056</b>	<b>F5-1058</b>	<b>F5-1126</b>	<b>F8-5217</b>	<b>F8-5227</b>	<b>F8-5236</b>	<b>F8-5307</b>
Ref.Nr.: 2711550016	Ref.Nr.: 6461500260	Ref.Nr.: 05175811AA	Ref.Nr.: 1243235685	Ref.Nr.: 2023230285	Ref.Nr.: 1243235485	Ref.Nr.: 2023338714
<b>F8-5327</b>	<b>F8-6539</b>	<b>F8-7747</b>	<b>F8-7858</b>	<b>F8-7899</b>	<b>F8-8079</b>	<b>F8-8153</b>
Ref.Nr.: 124323565	Ref.Nr.: 203 320 02 73	Ref.Nr.: 1402401218	Ref.Nr.: 2033331014	Ref.Nr.: 2123230392	Ref.Nr.: A204 323 00 44	Ref.Nr.: 2112403017
<b>LM-10082S</b>						
Ref.Nr.: 1714630096						

Article Description

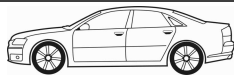

Article Nr.

Fitting Position



<b>CLK (C208)</b>			<b>06/1997 → 06/2002</b>		
Control Arm-/Trailing Arm Bush	200, 200 Kompressor , 230 Kompressor , 320, 430		<b>F8-5327</b>		d=11; D=36
Engine Mounting	200		<b>F8-5460</b>		
Engine Mounting	200		<b>F8-5461</b>		
Control Arm-/Trailing Arm Bush	200, 200 Kompressor , 230 Kompressor , 320, 430, 55 AMG		<b>F8-5477</b>		
Belt Pulley, crankshaft	200, 200 Kompressor , 230 Kompressor , 320, 430, 55 AMG	Parameter: 6PK	<b>F8-5663</b>		d=32; D1=160; D2=157; W1=82
Repair Set, axle beam	200, 200 Kompressor , 230 Kompressor , 320, 430	with fastening material; with accessories	<b>F8-5697</b>		
Control Arm-/Trailing Arm Bush	200, 200 Kompressor , 230 Kompressor , 320, 430		<b>F8-5698</b>		
Repair Set, axle beam	200, 200 Kompressor , 230 Kompressor , 320, 430, 55 AMG	with fastening material	<b>F8-6230</b>		
Joint, propshaft	200 Kompressor , 230 Kompressor , 320	with fastening material	<b>F8-6239</b>		Bolt Hole Circle Ø [mm]=100; d=46; D=140; W=29.8
Rubber Buffer, suspension	200, 200 Kompressor , 230 Kompressor , 320, 430, 55 AMG		<b>F8-6466</b>		
Control Arm-/Trailing Arm Bush	200, 200 Kompressor , 230 Kompressor , 320, 430		<b>F8-6467</b>		
Suspension Kit	200, 200 Kompressor , 230 Kompressor , 320, 430	with fastening material	<b>F8-6474</b>		
Control Arm-/Trailing Arm Bush	200, 200 Kompressor , 230 Kompressor , 320, 430	<b>SP</b>	<b>F8-6813</b>		H=99; d=10; W=48
Control Arm-/Trailing Arm Bush	55 AMG		<b>F8-6813</b>		H=99; d=10; W=48
Control Arm-/Trailing Arm Bush	200, 200 Kompressor , 230 Kompressor , 320, 430	<b>SP</b>	<b>F8-6814</b>		
Mounting, manual transmission	200, 200 Kompressor , 230 Kompressor , 320, 430		<b>F8-8178</b>		
Control Arm-/Trailing Arm Bush	200, 200 Kompressor , 230 Kompressor , 320, 430, 55 AMG		<b>G9-503</b>		H=43; d=12; D=31
Control Arm-/Trailing Arm Bush	200, 200 Kompressor , 230 Kompressor , 320, 430, 55 AMG		<b>G9-651</b>		d=12
Control Arm-/Trailing Arm Bush	200, 200 Kompressor , 230 Kompressor , 320, 430, 55 AMG		<b>G9-652</b>		d=13
<b>CLK Convertible (A208)</b>			<b>03/1998 → 03/2002</b>		
Stabiliser Mounting	200		<b>F8-5214</b>		d=18
Stabiliser Mounting	200	M 111.945	<b>F8-5236</b>		H=38; d=24; D=45
Control Arm-/Trailing Arm Bush	All Models		<b>F8-5307</b>		H=43; d=20; D=70
Control Arm-/Trailing Arm Bush	200, 200 Kompressor , 230 Kompressor , 320, 430		<b>F8-5327</b>		d=11; D=36
Engine Mounting	200		<b>F8-5460</b>		

<b>F8-5214</b>	<b>F8-5236</b>	<b>F8-5307</b>	<b>F8-5327</b>	<b>F8-5460</b>	<b>F8-5461</b>	<b>F8-5477</b>
Ref.Nr.: 1243234985	Ref.Nr.: 1243235485	Ref.Nr.: 2023338714	Ref.Nr.: 1243523565	Ref.Nr.: 2022401717	Ref.Nr.: 2102400617	Ref.Nr.: 2023336414
<b>F8-5663</b>	<b>F8-5697</b>	<b>F8-5698</b>	<b>F8-6230</b>	<b>F8-6239</b>	<b>F8-6466</b>	<b>F8-6467</b>
Ref.Nr.: 1120350800	Ref.Nr.: 1243506708	Ref.Nr.: 2023510842	Ref.Nr.: 1243516408	Ref.Nr.: 1704100015	Ref.Nr.: 210 325 03 84	Ref.Nr.: 208 333 01 14S
<b>F8-6474</b>	<b>F8-6813</b>	<b>F8-6814</b>	<b>F8-8178</b>	<b>G9-503</b>	<b>G9-651</b>	<b>G9-652</b>
Ref.Nr.: 202 330 01 75	Ref.Nr.: 2023337714	Ref.Nr.: 2023336214	Ref.Nr.: 2022400218	Ref.Nr.: 1243524365	Ref.Nr.: 1243529065	Ref.Nr.: 1243528665



Article Description



Article Nr.

Fitting Position



<b>CLK Convertible (A208)</b>			<b>03/1998 → 03/2002</b>	
Control Arm-/Trailing Arm Bush	All Models		<b>F8-5477</b>	
Belt Pulley, crankshaft	320, 430	Parameter: 6PK	<b>F8-5663</b>	d=32; D1=160; D2=157; W1=82
Repair Set, axle beam	200, 200 Kompressor , 230 Kompressor , 320, 430	with fastening material; with accessories	<b>F8-5697</b>	
Control Arm-/Trailing Arm Bush	200, 200 Kompressor , 230 Kompressor , 320, 430		<b>F8-5698</b>	
Repair Set, axle beam	All Models	with fastening material	<b>F8-6230</b>	
Joint, propshaft	200 Kompressor , 230 Kompressor , 320	with fastening material	<b>F8-6239</b>	
Rubber Buffer, suspension	All Models		<b>F8-6466</b>	
Control Arm-/Trailing Arm Bush	200, 200 Kompressor , 230 Kompressor , 320, 430		<b>F8-6467</b>	
Suspension Kit	200, 200 Kompressor , 230 Kompressor , 320, 430	with fastening material	<b>F8-6474</b>	
Control Arm-/Trailing Arm Bush	200, 200 Kompressor , 230 Kompressor , 320	<b>SP</b>	<b>F8-6813</b>	
Control Arm-/Trailing Arm Bush	200, 200 Kompressor , 230 Kompressor , 320	<b>SP</b>	<b>F8-6814</b>	
Mounting, manual transmission	200, 200 Kompressor , 230 Kompressor , 320		<b>F8-8178</b>	
Control Arm-/Trailing Arm Bush	200, 200 Kompressor , 230 Kompressor , 320, 430		<b>G9-503</b>	
Control Arm-/Trailing Arm Bush	200, 200 Kompressor , 230 Kompressor , 320, 430		<b>G9-651</b>	
Control Arm-/Trailing Arm Bush	200, 200 Kompressor , 230 Kompressor , 320, 430		<b>G9-652</b>	
<b>CLK (C209)</b>			<b>06/2002 → 05/2009</b>	
Dust Cover Kit, shock absorber	55 AMG , 63 AMG , CLK DTM AMG		<b>AK-735226</b>	
Alternator Freewheel Clutch	270 CDI		<b>F5-1018</b>	
Alternator Freewheel Clutch	200 CGI , 200 Kompressor		<b>F5-1056</b>	
Alternator Freewheel Clutch	220 CDI		<b>F5-1058</b>	
Alternator Freewheel Clutch	320 CDI		<b>F5-1126</b>	
Belt Pulley, crankshaft	200 CGI , 200 Kompressor , 220 CDI , 240, 270 CDI , 280, 320, 320 CDI , 350, 500, 55 AMG , 63 AMG , CLK DTM AMG	Parameter: 6PK	<b>F8-5663</b>	d=32; D1=160; D2=157; W1=82
Control Arm-/Trailing Arm Bush	200 CGI , 200 Kompressor , 240, 270 CDI , 320, 500, 55 AMG		<b>F8-5678</b>	
Control Arm-/Trailing Arm Bush	200 CGI , 200 Kompressor , 240, 270 CDI , 320, 500, 55 AMG		<b>F8-5872</b>	
Mounting, axle beam	200 CGI , 200 Kompressor , 240, 270 CDI , 320, 500, 55 AMG		<b>F8-5873</b>	
Stabiliser Mounting	200 CGI , 200 Kompressor , 240, 270 CDI , 320, 500	ch.→F085672	<b>F8-5980</b>	



Article Description

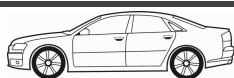

Article Nr.

Fitting Position



<b>CLK (C209)</b>				<b>06/2002 → 05/2009</b>	
Repair Kit, suspension strut	200 CGI , 200 Kompressor , 220 CDI , 240 , 270 CDI , 280, 320, 320 CDI , 350, 500, 55 AMG , 63 AMG , CLK DTM AMG	⊗	<b>F8-6539</b>		
Joint, propshaft	220 CDI , 270 CDI , 320 CDI , 350, 500	with fastening material	<b>F8-6760</b>		d=57.5; D=145; Thick./Strength 1 [mm]=31.5
Engine Mounting	200 CGI , 200 Kompressor		<b>F8-6950</b>		
Engine Mounting	200 CGI , 200 Kompressor		<b>F8-6951</b>		
Engine Mounting	200 CGI , 200 Kompressor	Aluminium	<b>F8-7747</b>		L=104
Engine Mounting	220 CDI , 320 CDI	Aluminium;	<b>F8-7747</b>		L=104
Engine Mounting	270 CDI	Aluminium; not for	<b>F8-7747</b>		L=104
Mounting, steering gear	200 CGI , 200 Kompressor , 220 CDI , 240 , 270 CDI , 280, 320, 320 CDI , 350, 500, 55 AMG , 63 AMG		<b>F8-7932</b>		
Engine Mounting	280, 350		<b>F8-8153</b>		
Engine Mounting	220 CDI , 270 CDI		<b>F8-8175</b>		
Control Arm-/Trailing Arm Bush	200 CGI , 200 Kompressor , 240, 270 CDI , 320, 500, 55 AMG		<b>G9-503</b>		H=43; d=12; D=31
Control Arm-/Trailing Arm Bush	200 CGI , 200 Kompressor , 240, 270 CDI , 320, 500, 55 AMG		<b>G9-651</b>		d=12
Control Arm-/Trailing Arm Bush	200 CGI , 200 Kompressor , 240, 270 CDI , 320, 500, 55 AMG		<b>G9-652</b>		d=13
<b>CLK Convertible (A209)</b>				<b>02/2003 → 03/2010</b>	
Dust Cover Kit, shock absorber	CLK 55 AMG , CLK 63 AMG		<b>AK-735226</b>		
Alternator Freewheel Clutch	CLK 200 CGI , CLK 200 Kompressor		<b>F5-1056</b>		
Alternator Freewheel Clutch	CLK 320 CDI		<b>F5-1126</b>		
Belt Pulley, crankshaft	CLK 240 , CLK 320 , CLK 500	Parameter: 6PK	<b>F8-5663</b>		d=32; D1=160; D2=157; W1=82
Control Arm-/Trailing Arm Bush	CLK 200 CGI , CLK 200 Kompressor , CLK 240 , CLK 320 , CLK 500 , CLK 55 AMG		<b>F8-5678</b>		H=58; d=12; D=33
Control Arm-/Trailing Arm Bush	CLK 200 CGI , CLK 200 Kompressor , CLK 240 , CLK 320 , CLK 500 , CLK 55 AMG		<b>F8-5872</b>		H1=60; H2=40; d=12; D=40
Mounting, axle beam	CLK 200 CGI , CLK 200 Kompressor , CLK 240 , CLK 320 , CLK 500 , CLK 55 AMG		<b>F8-5873</b>		H=29; d=15; D=66
Repair Kit, suspension strut	CLK 200 CGI , CLK 200 Kompressor , CLK 240 , CLK 280 , CLK 320 , CLK 320 CDI , CLK 350 , CLK 500 , CLK 55 AMG , CLK 63 AMG	⊗	<b>F8-6539</b>		
Joint, propshaft	CLK 320 CDI , CLK 350 , CLK 500	with fastening material	<b>F8-6760</b>		d=57.5; D=145; Thick./Strength 1 [mm]=31.5
Engine Mounting	CLK 200 Kompressor		<b>F8-6950</b>		
Engine Mounting	CLK 200 Kompressor		<b>F8-6951</b>		
Engine Mounting	CLK 200 Kompressor	Aluminium	<b>F8-7747</b>		L=104
Engine Mounting	CLK 320 CDI	Aluminium;	<b>F8-7747</b>		L=104



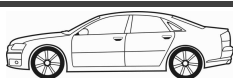

**Article Description****Article Nr.****Fitting Position**

<b>CLK Convertible (A209)</b>		<b>02/2003 → 03/2010</b>	
Mounting, steering gear	CLK 200 Kompressor , CLK 240 , CLK 280 , CLK 320 , CLK 320 CDI , CLK 350 , CLK 500 , CLK 55 AMG , CLK 63 AMG	<b>F8-7932</b>	
Engine Mounting	CLK 280 , CLK 350	<b>F8-8153</b>	
Control Arm-/Trailing Arm Bush	CLK 200 CGI , CLK 200 Kompressor , CLK 240 , CLK 320 , CLK 500 , CLK 55 AMG	<b>G9-503</b>	H=43; d=12; D=31
Control Arm-/Trailing Arm Bush	CLK 200 CGI , CLK 200 Kompressor , CLK 240 , CLK 320 , CLK 500 , CLK 55 AMG	<b>G9-651</b>	d=12
Control Arm-/Trailing Arm Bush	CLK 200 CGI , CLK 200 Kompressor , CLK 240 , CLK 320 , CLK 500 , CLK 55 AMG	<b>G9-652</b>	d=13
<b>CLS (C218)</b>		<b>01/2011 →</b>	
Alternator Freewheel Clutch	CLS 350 BlueTEC, CLS 350 BlueTEC 4-matic, CLS 350 CDI , CLS 350 CDI 4-matic	<b>F5-1126</b>	
Rubber Buffer, suspension	CLS 250 CDI , CLS 350 , CLS 350 CDI , CLS 350 CDI 4-matic , CLS 500 , CLS 500 4-matic	<b>F8-7691</b>	
Protective Cap/Bellow, shock absorber	CLS 250 CDI , CLS 350 , CLS 350 BlueTEC, CLS 350 BlueTEC 4-matic, CLS 350 CDI , CLS 350 CDI 4-matic , CLS 500 , CLS 500 4-matic , CLS 63 AMG, CLS 63 AMG 4-matic	<b>F8-7899</b>	for vehicles without electronic drive dynamics regulation H=224
Control Arm-/Trailing Arm Bush	CLS 250 BlueTEC 4-matic, CLS 250 CDI , CLS 300 CGI, CLS 350 , CLS 350 BlueTEC 4-matic, CLS 350 CDI , CLS 350 CDI 4-matic , CLS 350 d 4-matic, CLS 400 4-matic, CLS 500 , CLS 500 4-matic	<b>F8-8116</b>	H=80; d=14,2; D=75,5
Bellow, driveshaft	CLS 250 BlueTEC 4-matic, CLS 350 BlueTEC 4-matic, CLS 350 CDI 4-matic , CLS 350 d 4-matic	<b>M-871000</b>	
Bellow Set, drive shaft	CLS 250 BlueTEC 4-matic, CLS 350 BlueTEC 4-matic, CLS 350 CDI 4-matic , CLS 350 d 4-matic	<b>MK-871000</b>	
<b>CLS (C219)</b>		<b>10/2004 → 12/2010</b>	
Dust Cover Kit, shock absorber	CLS 280 , CLS 300 , CLS 320 CDI , CLS 350 , CLS 350 CDI , CLS 350 CGI , CLS 500 , CLS 55 AMG , CLS 63 AMG	<b>AK-735227</b>	
Alternator Freewheel Clutch	CLS 320 CDI , CLS 350 CDI	<b>F5-1065</b>	
Alternator Freewheel Clutch	CLS 320 CDI , CLS 350 CDI	<b>F5-1126</b>	
Belt Pulley, crankshaft	CLS 500	<b>F8-5663</b>	Parameter: 6PK d=32; D1=160; D2=157; W1=82
Top Strut Mounting	CLS 280 , CLS 320 CDI , CLS 350 , CLS 500 , CLS 55 AMG , CLS 63 AMG	<b>F8-6059</b>	
Top Strut Mounting	CLS 300 , CLS 350 CDI , CLS 350 CGI	<b>F8-6059</b>	
Control Arm-/Trailing Arm Bush	CLS 350 , CLS 500 , CLS 55 AMG	<b>F8-6112</b>	
Control Arm-/Trailing Arm Bush	CLS 350 , CLS 500 , CLS 55 AMG , CLS 63 AMG	<b>F8-6113</b>	H=56; d=14; D=52
Control Arm-/Trailing Arm Bush	CLS 280 , CLS 350 , CLS 500	<b>F8-6145</b>	d=12.2

<b>AK-735227</b>	<b>F5-1065</b>	<b>F5-1126</b>	<b>F8-5663</b>	<b>F8-6059</b>	<b>F8-6112</b>	<b>F8-6113</b>
Ref.Nr.:	Ref.Nr.: 6281500060	Ref.Nr.: 05175811AA	Ref.Nr.: 1120350800	Ref.Nr.: 2113200026	Ref.Nr.: 2113332914	Ref.Nr.: 2113331914
<b>F8-6145</b>	<b>F8-6161</b>	<b>F8-7691</b>		<b>F8-7932</b>		
Ref.Nr.: 2303521565	Ref.Nr.: 2113520865	Ref.Nr.: 2123210706	Ref.Nr.: 2123230392	Ref.Nr.: 2033330514	Ref.Nr.: A2123330314	Ref.Nr.: 2112403017
<b>G9-503</b>	<b>G9-651</b>	<b>G9-652</b>				
Ref.Nr.: 1243524365	Ref.Nr.: 1243529065	Ref.Nr.: 1243528665	Ref.Nr.: 2213300285	Ref.Nr.: A2213300285		
			<b>M-871000</b>	<b>MK-871000</b>		
			Ref.Nr.: 2213300285	Ref.Nr.: A2213300285		

**Article Description**

**Article Nr.**
**Fitting Position**

<b>CLS (C219)</b>		<b>10/2004 → 12/2010</b>	
Tie Bar Bush	CLS 55 AMG , CLS 63 AMG	<b>F8-6161</b>	
Mounting, axle beam	CLS 350 , CLS 500	<b>F8-6181</b>	
Mounting, axle beam	CLS 350 , CLS 500 , CLS 55 AMG , CLS 63 AMG	<b>F8-6182</b>	H=78; d=12; D=51.5
Mounting, axle beam	CLS 350 , CLS 500 , CLS 55 AMG , CLS 63 AMG	<b>F8-6184</b>	
Control Arm-/Trailing Arm Bush	CLS 320 CDI , CLS 350 , CLS 500	<b>F8-6651</b>	
Joint, propshaft	CLS 350 , CLS 500	<b>F8-6760</b>	with fastening material d=57.5; D=145; Thick./Strength 1 [mm]=31.5
Joint, propshaft	CLS 350 , CLS 350 CGI , CLS 500	<b>F8-7721S</b>	with fastening material
Control Arm-/Trailing Arm Bush	CLS 280 , CLS 300 , CLS 320 CDI , CLS 350 , CLS 350 CDI , CLS 500	<b>F8-8129</b>	d=12; D=38,5
Control Arm-/Trailing Arm Bush	CLS 280 , CLS 300 , CLS 320 CDI , CLS 350 , CLS 350 CDI , CLS 350 CGI , CLS 500 , CLS 550	<b>F8-8130</b>	
Engine Mounting	CLS 280 , CLS 300 , CLS 320 CDI , CLS 350 , CLS 350 CDI , CLS 350 CGI	<b>F8-8153</b>	
<b>CLS Shooting Brake (X218)</b>		<b>10/2012 →</b>	
Top Strut Mounting	CLS 250 CDI , CLS 350 , CLS 350 CDI , CLS 350 CDI 4-matic , CLS 500 , CLS 500 4-matic , CLS 63 AMG	<b>F8-7626</b>	
Protective Cap/Bellow, shock absorber	CLS 250 CDI , CLS 350 , CLS 350 CDI , CLS 350 CDI 4-matic , CLS 500 , CLS 500 4-matic , CLS 63 AMG , CLS 63 AMG 4-matic	<b>F8-7899</b>	for vehicles without electronic drive dynamics regulation H=224
Control Arm-/Trailing Arm Bush	CLS 250 BlueTEC 4-matic , CLS 250 CDI , CLS 350 , CLS 350 BlueTEC 4-matic , CLS 350 CDI , CLS 350 CDI 4-matic , CLS 350 d 4-matic , CLS 400 4-matic , CLS 500 , CLS 500 4-matic	<b>F8-8116</b>	H=80; d=14,2; D=75,5
Bellow, driveshaft	CLS 250 BlueTEC 4-matic , CLS 350 BlueTEC 4-matic , CLS 350 CDI 4-matic , CLS 350 d 4-matic	<b>M-871000</b>	
Bellow Set, drive shaft	CLS 250 BlueTEC 4-matic , CLS 350 BlueTEC 4-matic , CLS 350 CDI 4-matic , CLS 350 d 4-matic	<b>MK-871000</b>	
<b>COUPE (C123)</b>		<b>03/1977 → 12/1985</b>	
Repair Kit, reversing lever	230 C , 230 CE , 280 C , 280 CE	<b>F7-9001</b>	
Mounting, propshaft	230 C , 230 CE , 280 C , 280 CE	<b>F8-4001</b>	H=108; d=55; D=95; T [mm]=128
Control Arm-/Trailing Arm Bush	230 C , 230 CE , 280 C , 280 CE	<b>F8-4005</b>	H=64.5; d=16.4; D1=42; D2=53
Suspension Kit	230 C , 230 CE , 280 C , 280 CE	<b>F8-5020</b>	
Stabiliser Mounting	230 C , 230 CE , 280 C , 280 CE	<b>F8-5137</b>	H=50; d=21; W=74
Suspension Kit	230 C , 230 CE , 280 C , 280 CE	<b>F8-5178</b>	
Stabiliser Mounting	230 C , 280 C , 280 CE	<b>F8-5670</b>	d=13
Repair Set, axle beam	230 C , 230 CE , 280 C , 280 CE	<b>F8-5730</b>	d=16; L=65; D=54
Repair Set, axle beam	230 C	<b>F8-5731</b>	ch.→015205

<b>F7-9001</b>	<b>F8-4001</b>	<b>F8-4005</b>	<b>F8-5020</b>	<b>F8-5137</b>	<b>F8-5178</b>	<b>F8-5670</b>
Ref.Nr.: 1234600050	Ref.Nr.: 1164102781	Ref.Nr.: 1153523265	Ref.Nr.: 1165860133	Ref.Nr.: 1233230585	Ref.Nr.: 1233301375	Ref.Nr.: 2013261081
<b>F8-5730</b>	<b>F8-5731</b>	<b>F8-6161</b>	<b>F8-6181</b>	<b>F8-6182</b>	<b>F8-6184</b>	<b>F8-6651</b>
Ref.Nr.: 1153523665	Ref.Nr.: 1233500075	Ref.Nr.: 2113520865	Ref.Nr.: 2303510242	Ref.Nr.: 2203521365	Ref.Nr.: 2113511442	Ref.Nr.: 2113332214
<b>F8-6760</b>	<b>F8-7626</b>	<b>F8-7721S</b>	<b>F8-7899</b>	<b>F8-8116</b>	<b>F8-8129</b>	<b>F8-8130</b>
Ref.Nr.: 0004110200	Ref.Nr.: A2043260664	Ref.Nr.: 2114100415	Ref.Nr.: 2123230392	Ref.Nr.: A2123330314	Ref.Nr.: 2303521865	Ref.Nr.: A2303521465

**Article Description****Article Nr.****Fitting Position**

<b>COUPE (C123)</b>		<b>03/1977 → 12/1985</b>	
Repair Set, axle beam	280 C , 280 CE		<b>F8-5731</b>
Mounting, axle beam	230 C , 230 CE , 280 C , 280 CE		<b>F8-5732</b>
Repair Set, axle beam	230 C	ch.015206→	<b>F8-5739</b>
Repair Set, axle beam	230 CE		<b>F8-5739</b>
Rubber Buffer, suspension	230 C , 230 CE , 280 C , 280 CE		<b>F8-5770</b>
Joint, propshaft	280 C , 280 CE		<b>F8-6235</b>
Mounting, manual transmission	280 CE		<b>F8-6498</b>
Mounting, manual transmission	280 CE	5-speed; Type: 123.053	<b>F8-6498</b>
Engine Mounting	230 CE		<b>F8-8194</b>
Control Arm-/Trailing Arm Bush	All Models		<b>G9-514</b>
Control Arm-/Trailing Arm Bush	230 C , 230 CE , 280 C , 280 CE		<b>G9-588</b>
Control Arm-/Trailing Arm Bush	300 C Turbo-D		<b>G9-652</b>
<b>COUPE (C124)</b>		<b>03/1987 → 05/1993</b>	
Dust Cover Kit, shock absorber	220 CE , 230 CE , 300 CE , 300 CE-24 , 320 CE		<b>AK-735019</b>
Engine Mounting	230 CE		<b>F7-2003</b>
Repair Kit, reversing lever	230 CE , 300 CE , 300 CE-24		<b>F7-9001</b>
Engine Mounting	300 CE		<b>F8-2005</b>
Engine Mounting	300 CE-24		<b>F8-2005</b>
Mounting, propshaft	230 CE		<b>F8-4002</b>
Mounting, propshaft	230 CE		<b>F8-4003</b>
Engine Mounting	230 CE , 300 CE		<b>F8-5005</b>
Suspension Kit	230 CE , 300 CE , 300 CE-24	ch.→B711095;	<b>F8-5009</b>
Control Arm-/Trailing Arm Bush	230 CE , 300 CE , 300 CE-24		<b>F8-5010</b>
Mounting, axle beam	230 CE		<b>F8-5018</b>
Repair Kit, link	230 CE , 300 CE , 300 CE-24	ch.→B711095;	<b>F8-5185</b>
Suspension Kit	220 CE , 320 CE	ch.B711096, C017669→;	<b>F8-5195</b>
Suspension Kit	300 CE	ch.B711096→; 09/1989 →;	<b>F8-5195</b>
Suspension Kit	300 CE-24	ch.B711096→;	<b>F8-5195</b>
Stabiliser Mounting	230 CE , 300 CE , 300 CE-24		<b>F8-5214</b>
Stabiliser Mounting	230 CE	10/1992 →	<b>F8-5217</b>
Stabiliser Mounting	300 CE , 300 CE-24		<b>F8-5217</b>
Stabiliser Mounting	230 CE		<b>F8-5218</b>

<b>AK-735019</b>	<b>F7-2003</b>	<b>F7-9001</b>	<b>F8-2005</b>	<b>F8-4002</b>	<b>F8-4003</b>	<b>F8-5005</b>
Ref.Nr.: 1293230192	Ref.Nr.: 1242400217	Ref.Nr.: 1234600050	Ref.Nr.: 1242401917	Ref.Nr.: 1244100181	Ref.Nr.: 1244100281	Ref.Nr.: 1242400317
<b>F8-5009</b>	<b>F8-5010</b>	<b>F8-5018</b>	<b>F8-5185</b>	<b>F8-5195</b>	<b>F8-5214</b>	<b>F8-5217</b>
Ref.Nr.: 1243300275	Ref.Nr.: 2013335114	Ref.Nr.: 2013512742	Ref.Nr.: 2013300175	Ref.Nr.: 1243300675	Ref.Nr.: 1243234985	Ref.Nr.: 1243235685
<b>F8-5218</b>	<b>F8-5219</b>	<b>F8-5731</b>	<b>F8-5732</b>	<b>F8-5739</b>	<b>F8-5770</b>	<b>F8-6235</b>
Ref.Nr.: 2013234985	Ref.Nr.: 1243233785	Ref.Nr.: 1233500075	Ref.Nr.: 1233511042	Ref.Nr.: 1233500175	Ref.Nr.: 1153200344	Ref.Nr.: 1264100215

Article Description



Article Nr.

Fitting Position



<b>COUPE (C124)</b>				<b>03/1987 → 05/1993</b>	
Stabiliser Mounting	230 CE		<b>F8-5219</b>		d=24
Stabiliser Mounting	220 CE		<b>F8-5236</b>		H=38; d=24; D=45
Control Arm-/Trailing Arm Bush	220 CE , 230 CE , 300 CE , 300 CE-24 , 320 CE		<b>F8-5297</b>		H=48; d=14.1; D=40.03
Control Arm-/Trailing Arm Bush	230 CE , 300 CE , 300 CE-24		<b>F8-5327</b>		d=11; D=36
Engine Mounting	300 CE		<b>F8-5449</b>		
Engine Mounting	300 CE-24 , 320 CE		<b>F8-5449</b>		
Top Strut Mounting	220 CE , 230 CE , 300 CE , 300 CE-24 , 320 CE		<b>F8-5502</b>		d=14.5; D=59; Thick. [mm]=130
Stabiliser Mounting	300 CE, 300 CE-24, 320 CE		<b>F8-5670</b>		d=13
Control Arm-/Trailing Arm Bush	220 CE , 230 CE , 300 CE , 300 CE-24 , 320 CE		<b>F8-5678</b>		H=58; d=12; D=33
Mounting, axle beam	230 CE , 300 CE , 300 CE-24		<b>F8-5733</b>		H=30; d=14; D=47
Mounting, axle beam	220 CE , 230 CE , 300 CE , 300 CE-24 , 320 CE		<b>F8-5744</b>		
Mounting, axle beam	230 CE , 300 CE , 300 CE-24		<b>F8-5773</b>		H=70; D=70
Repair Set, axle beam	300 CE , 300 CE-24 , 320 CE		<b>F8-5820</b>		
Mounting, axle beam	300 CE , 300 CE-24 , 320 CE		<b>F8-5821</b>		H=59; d=16; D=66
Rubber Buffer, suspension	220 CE , 230 CE , 300 CE, 300 CE-24, 320 CE		<b>F8-5901</b>		
Rubber Buffer, suspension	220 CE , 230 CE , 300 CE, 300 CE-24, 320 CE		<b>F8-5914</b>		H=75
Rubber Buffer, suspension	220 CE , 230 CE , 300 CE, 300 CE-24, 320 CE		<b>F8-5918</b>		
Stabiliser Mounting	220 CE , 230 CE		<b>F8-5973</b>		H=38,5; d=25; D=45
Repair Set, axle beam	220 CE , 230 CE	with fastening material	<b>F8-6230</b>		
Joint, propshaft	300 CE-24 , 320 CE	with fastening material	<b>F8-6239</b>		Bolt Hole Circle Ø [mm]=100; d=46; D=140; W=29.8
Control Arm-/Trailing Arm Bush	220 CE , 230 CE , 300 CE, 300 CE-24, 320 CE		<b>F8-6468</b>		H=48; d=16; D=49
Suspension Kit	220 CE , 230 CE , 300 CE , 300 CE-24 , 320 CE		<b>F8-6473</b>		
Mounting, manual transmission	220 CE , 230 CE , 300 CE , 300 CE-24 , 320 CE		<b>F8-6498</b>		
Mounting, manual transmission	300 CE	Type: 124.050	<b>F8-6498</b>		
Control Arm-/Trailing Arm Bush	230 CE	ch.C017669→; 09/1989 →;	<b>F8-6804</b>		
Control Arm-/Trailing Arm Bush	230 CE , 300 CE , 300 CE-24	ch.B711096→;	<b>F8-6804</b>		
Control Arm-/Trailing Arm Bush	300 CE	ch.B711096, C017669→; 09/1989 →;	<b>F8-6804</b>		
Control Arm-/Trailing Arm Bush	300 CE-24	ch.C017669→;	<b>F8-6804</b>		
Control Arm-/Trailing Arm Bush	230 CE , 300 CE	ch.C017669→; 09/1989 →;	<b>F8-6805</b>		

<b>F8-5219</b>	<b>F8-5236</b>	<b>F8-5297</b>	<b>F8-5327</b>	<b>F8-5449</b>	<b>F8-5502</b>	<b>F8-5670</b>
Ref.Nr.: 1243233785	Ref.Nr.: 1243235485	Ref.Nr.: 2043520027	Ref.Nr.: 1243523565	Ref.Nr.: 2012404117	Ref.Nr.: A1243201444	Ref.Nr.: 2013261081
<b>F8-5678</b>	<b>F8-5733</b>	<b>F8-5744</b>	<b>F8-5773</b>	<b>F8-5820</b>	<b>F8-5821</b>	<b>F8-5901</b>
Ref.Nr.: 1293520065	Ref.Nr.: 1243524165	Ref.Nr.: 1243511342	Ref.Nr.: 1243510242	Ref.Nr.: 1243508608	Ref.Nr.: 1293511542	Ref.Nr.: 2013232044
<b>F8-5914</b>	<b>F8-5918</b>	<b>F8-5973</b>	<b>F8-6230</b>	<b>F8-6239</b>	<b>F8-6468</b>	<b>F8-6473</b>
Ref.Nr.: 1293230744	Ref.Nr.: 1243230744	Ref.Nr.: 1243234485	Ref.Nr.: 1243516408	Ref.Nr.: 1704100015	Ref.Nr.: 201 333 52 14	Ref.Nr.: 1243300975



Article Description



Article Nr.

Fitting Position



<b>COUPE (C124)</b>				<b>03/1987 → 05/1993</b>	
Control Arm-/Trailing Arm Bush	300 CE-24	ch.C017669→; <b>SP</b> , <b>SR</b>	<b>F8-6805</b>		
Joint, propshaft	220 CE, 230 CE, 300 CE	with add-on material	<b>F8-7130</b>		Bolt Hole Circle Ø [mm]=90
Control Arm-/Trailing Arm Bush	220 CE, 230 CE, 300 CE, 300 CE-24, 320 CE		<b>G9-503</b>		H=43; d=12; D=31
Control Arm-/Trailing Arm Bush	220 CE, 230 CE, 300 CE, 300 CE-24, 320 CE		<b>G9-651</b>		d=12
Control Arm-/Trailing Arm Bush	220 CE, 230 CE, 300 CE, 300 CE-24, 320 CE		<b>G9-652</b>		d=13
<b>COUPE (W111)</b>				<b>01/1967 → 12/1971</b>	
Joint, propshaft	280 SE, 280 SE 3.5		<b>F8-6235</b>		Bolt Hole Circle Ø [mm]=90
<b>E-CLASS (W124)</b>				<b>06/1993 → 06/1995</b>	
Dust Cover Kit, shock absorber	E 200, E 200 D, E 220, E 250 D, E 250 Turbo-D, E 280 long, E 300 D, E 300 Turbo-D, E 320, E 420, E 500		<b>AK-735019</b>		
Engine Mounting	E 200 D		<b>F7-2003</b>		
Repair Kit, reversing lever	E 200, E 200 D, E 220, E 250 D, E 250 Turbo-D, E 280, E 280 long, E 300 4-matic, E 300 D, E 300 Turbo-D, E 320, E 420, E 500		<b>F7-9001</b>		
Mounting, propshaft	E 200, E 200 D, E 250 D		<b>F8-4002</b>		H=89; d=43; D=83; T [mm]=119
Mounting, propshaft	E 200, E 200 D, E 250 D		<b>F8-4003</b>		H=100; d=50; D=93; T [mm]=119
Engine Mounting	E 420, E 500		<b>F8-5004</b>		H=105; d=8; D=118; T [mm]=149
Engine Mounting	E 250 D		<b>F8-5005</b>		H=111; D1=90; D2=103
Engine Mounting	E 250 Turbo-D		<b>F8-5005</b>		H=111; D1=90; D2=103
Suspension Kit	E 200 D, E 250 Turbo-D, E 300 Turbo-D	ch.→B711095; <b>SP</b>	<b>F8-5009</b>		
Suspension Kit	E 500	ch.→B711095	<b>F8-5009</b>		
Control Arm-/Trailing Arm Bush	E 200, E 200 D, E 220, E 250 D, E 250 Turbo-D, E 280, E 280 long, E 300 D, E 300 Turbo-D, E 320, E 420, E 500		<b>F8-5010</b>		H=49; d=16; D1=49; D2=65
Suspension Kit	E 200, E 250 D, E 250 Turbo-D, E 500	<b>SP</b>	<b>F8-5011</b>		
Mounting, axle beam	E 200, E 200 D, E 220, E 250 D, E 250 Turbo-D, E 300 D, E 300 Turbo-D		<b>F8-5018</b>		H=58; D1=68; D2=81
Repair Kit, link	E 200 D, E 250 Turbo-D, E 300 Turbo-D	ch.→B711095; <b>SP</b>	<b>F8-5185</b>		
Suspension Kit	E 200, E 220, E 250 D, E 280, E 300 D, E 320	ch.B711096, C018228→; <b>SP</b> , <b>SR</b>	<b>F8-5195</b>		
Suspension Kit	E 200 D, E 250 Turbo-D, E 300 Turbo-D	ch.C018228→; <b>SP</b>	<b>F8-5195</b>		
Suspension Kit	E 420, E 500	ch.B711096→	<b>F8-5195</b>		
Stabiliser Mounting	E 250 D, E 280 long, E 420		<b>F8-5209</b>		H=36; d=22.5; D=38
Stabiliser Mounting	E 200, E 220, E 250 D, E 280, E 300 D, E 320		<b>F8-5214</b>		d=18
Stabiliser Mounting	E 200 D, E 250 Turbo-D, E 300 Turbo-D	07/1993 →	<b>F8-5214</b>		d=18

<b>AK-735019</b>	<b>F7-2003</b>	<b>F7-9001</b>	<b>F8-4002</b>	<b>F8-4003</b>	<b>F8-5004</b>	<b>F8-5005</b>
Ref.Nr.: 1293230192	Ref.Nr.: 1242400217	Ref.Nr.: 1234600050	Ref.Nr.: 1244100181	Ref.Nr.: 1244100281	Ref.Nr.: 1292400917	Ref.Nr.: 1242400317
<b>F8-5009</b>	<b>F8-5010</b>	<b>F8-5011</b>	<b>F8-5018</b>	<b>F8-5185</b>	<b>F8-5195</b>	<b>F8-5209</b>
Ref.Nr.: 1243300275	Ref.Nr.: 2013335114	Ref.Nr.: 2013300075	Ref.Nr.: 2013512742	Ref.Nr.: 2013300175	Ref.Nr.: 1243300675	Ref.Nr.: 1243235085
<b>F8-5214</b>	<b>F8-5216</b>	<b>F8-6235</b>	<b>F8-6805</b>	<b>F8-7130</b>	<b>G9-503</b>	<b>G9-651</b>
Ref.Nr.: 1243234985	Ref.Nr.: 1243232885	Ref.Nr.: 1264100215	Ref.Nr.: 1243334314	Ref.Nr.: 1264100515	Ref.Nr.: 1243524365	Ref.Nr.: 1243529065

Article Description



Article Nr.

Fitting Position



<b>E-CLASS (W124)</b>				<b>06/1993 → 06/1995</b>	
Stabiliser Mounting	E 250 D , E 280 long		<b>F8-5216</b>		d=28.5
Stabiliser Mounting	E 200 , E 200 D , E 220 , E 250 D , E 250 Turbo-D , E 280 , E 300 D , E 320 , E 420		<b>F8-5217</b>		d=26.5
Stabiliser Mounting	E 200 , E 200 D		<b>F8-5218</b>		d=23
Stabiliser Mounting	E 200 D		<b>F8-5219</b>		d=24
Stabiliser Mounting	E 200 , E 220		<b>F8-5236</b>		H=38; d=24; D=45
Stabiliser Mounting	E 200 D	07/1993 →;	<b>F8-5236</b>		H=38; d=24; D=45
Control Arm-/Trailing Arm Bush	E 200 , E 200 D , E 220 , E 250 D , E 250 Turbo-D , E 280 , E 280 long , E 300 4-matic , E 300 D , E 300 Turbo-D , E 300 Turbo-D 4-matic , E 320 , E 420 , E 500 , E 60 AMG		<b>F8-5297</b>		H=48; d=14.1; D=40.03
Control Arm-/Trailing Arm Bush	E 200 , E 200 D , E 220 , E 250 D , E 250 Turbo-D , E 280 , E 280 long , E 300 4-matic , E 300 D , E 300 Turbo-D , E 300 Turbo-D 4-matic , E 320 , E 420 , E 500		<b>F8-5327</b>		d=11; D=36
Mounting, axle beam	E 200 , E 200 D , E 220 , E 250 D , E 250 Turbo-D , E 300 D		<b>F8-5420</b>		d=16; D=51; Thick. [mm]=58
Engine Mounting	E 250 D		<b>F8-5449</b>		
Engine Mounting	E 250 Turbo-D		<b>F8-5449</b>		
Engine Mounting	E 280 , E 280 long , E 300 D , E 320		<b>F8-5449</b>		
Engine Mounting	E 300 Turbo-D		<b>F8-5449</b>		
Top Strut Mounting	E 200 , E 200 D , E 220 , E 250 D , E 250 Turbo-D , E 280 , E 280 long , E 300 D , E 300 Turbo-D , E 300 Turbo-D 4-matic , E 320 , E 420 , E 500		<b>F8-5502</b>		d=14.5; D=59; Thick. [mm]=130
Stabiliser Mounting	E 200 D , E 250 Turbo-D		<b>F8-5670</b>		d=13
Control Arm-/Trailing Arm Bush	E 200 , E 200 D , E 220 , E 250 D , E 250 Turbo-D , E 280 , E 280 long , E 300 4-matic , E 300 D , E 300 Turbo-D , E 300 Turbo-D 4-matic , E 320 , E 420 , E 500		<b>F8-5678</b>		H=58; d=12; D=33
Mounting, axle beam	E 200 , E 200 D , E 220 , E 250 D , E 250 Turbo-D , E 280 , E 280 long , E 300 4-matic , E 300 D , E 300 Turbo-D , E 300 Turbo-D 4-matic , E 320 , E 420 , E 500		<b>F8-5744</b>		
Repair Set, axle beam	E 280 , E 280 long , E 300 4-matic , E 320 , E 420 , E 500		<b>F8-5820</b>		
Mounting, axle beam	E 280 , E 280 long , E 300 4-matic , E 320 , E 420 , E 500		<b>F8-5821</b>		H=59; d=16; D=66
Rubber Buffer, suspension	E 200 , E 200 D , E 220 , E 250 D , E 250 Turbo-D , E 280 , E 280 long , E 300 4-matic , E 300 D , E 300 Turbo-D , E 300 Turbo-D 4-matic , E 320 , E 420 , E 500		<b>F8-5901</b>		
Rubber Buffer, suspension	E 200 , E 200 D , E 220 , E 250 D , E 250 Turbo-D , E 280 , E 300 D , E 300 Turbo-D , E 320		<b>F8-5914</b>		H=75



**Article Description****Article Nr.****Fitting Position**

<b>E-CLASS (W124)</b>		<b>06/1993 → 06/1995</b>	
Rubber Buffer, suspension	E 200 , E 200 D , E 220 , E 250 D , E 250 Turbo-D , E 280 , E 300 D , E 300 Turbo-D , E 320 , E 420		<b>F8-5918</b>
Stabiliser Mounting	E 200 , E 220	<b>SP</b>	<b>F8-5973</b> H=38,5; d=25; D=45
Repair Set, axle beam	E 200 , E 200 D , E 220 , E 250 D , E 250 Turbo-D , E 280 , E 280 long , E 300 D , E 300 Turbo-D , E 300 Turbo-D 4-matic , E 320	with fastening material	<b>F8-6230</b>
Joint, propshaft	E 280 , E 280 long	with fastening material;	<b>F8-6239</b> Bolt Hole Circle Ø [mm]=100; d=46; D=140; W=29.8
Joint, propshaft	E 280 , E 280 long , E 320	with fastening material	<b>F8-6239</b> Bolt Hole Circle Ø [mm]=100; d=46; D=140; W=29.8
Control Arm-/Trailing Arm Bush	E 200 , E 200 D , E 220 , E 250 D , E 250 Turbo-D , E 280 , E 280 long , E 300 4-matic , E 300 D , E 300 Turbo-D , E 300 Turbo-D 4-matic , E 320 , E 420 , E 500 , E 60 AMG		<b>F8-6468</b> H=48; d=16; D=49
Suspension Kit	E 200 , E 200 D , E 220 , E 250 D , E 250 Turbo-D , E 280 , E 300 D , E 300 Turbo-D , E 320		<b>F8-6473</b>
Mounting, manual transmission	E 200 , E 200 D , E 220 , E 250 D , E 250 Turbo-D , E 280 , E 280 long , E 300 4-matic , E 300 D , E 300 Turbo-D , E 300 Turbo-D 4-matic , E 320 , E 420 , E 500		<b>F8-6498</b>
Control Arm-/Trailing Arm Bush	E 200 , E 200 D , E 220 , E 250 D , E 250 Turbo-D , E 280 , E 280 long , E 300 D , E 300 Turbo-D , E 320 , E 420 , E 500 , E 60 AMG	ch.B711096→; <b>SP</b>	<b>F8-6804</b>
Control Arm-/Trailing Arm Bush	E 200 , E 200 D , E 220 , E 250 Turbo-D , E 280 , E 300 D , E 300 Turbo-D , E 320	ch.C018228→; <b>SP</b>	<b>F8-6804</b>
Control Arm-/Trailing Arm Bush	E 250 D	ch.C018228→; <b>SP</b> ; Type: 124.126	<b>F8-6804</b>
Control Arm-/Trailing Arm Bush	E 200 , E 200 D , E 220 , E 250 Turbo-D , E 280 , E 300 D , E 300 Turbo-D , E 320	ch.C018228→; <b>SP</b> , <b>SP</b>	<b>F8-6805</b>
Control Arm-/Trailing Arm Bush	E 250 D	ch.C018228→; <b>SP</b> , <b>SP</b> ; Type: 124.126	<b>F8-6805</b>
Control Arm-/Trailing Arm Bush	E 280 long , E 420 , E 500 , E 60 AMG	ch.B711096→; <b>SP</b>	<b>F8-6805</b>
Joint, propshaft	E 200 , E 200 D , E 220 , E 250 D , E 250 Turbo-D , E 300 D	with add-on material	<b>F8-7130</b> Bolt Hole Circle Ø [mm]=90
Control Arm-/Trailing Arm Bush	E 200 , E 200 D , E 220 , E 250 D , E 250 Turbo-D , E 280 , E 280 long , E 300 4-matic , E 300 D , E 300 Turbo-D , E 300 Turbo-D 4-matic , E 320 , E 420 , E 500		<b>G9-503</b> H=43; d=12; D=31
Control Arm-/Trailing Arm Bush	E 200 , E 200 D , E 220 , E 250 D , E 250 Turbo-D , E 280 , E 280 long , E 300 4-matic , E 300 D , E 300 Turbo-D , E 300 Turbo-D 4-matic , E 320 , E 420 , E 500		<b>G9-651</b> d=12
Control Arm-/Trailing Arm Bush	E 200 , E 200 D , E 220 , E 250 D , E 250 Turbo-D , E 280 , E 280 long , E 300 4-matic , E 300 D , E 300 Turbo-D , E 300 Turbo-D 4-matic , E 320 , E 420 , E 500		<b>G9-652</b> d=13



Article Description

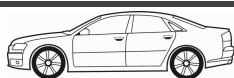

Article Nr.

Fitting Position



<b>E-CLASS Convertible (A124)</b>			<b>06/1993 → 03/1998</b>	
Dust Cover Kit, shock absorber	All Models		<b>AK-735019</b>	
Suspension Kit	E 200	<b>SP</b>	<b>F8-5011</b>	
Suspension Kit	All Models	ch.B711096→	<b>F8-5195</b>	
Stabiliser Mounting	E 320		<b>F8-5216</b>	d=28.5
Control Arm-/Trailing Arm Bush	All Models		<b>F8-5297</b>	H=48; d=14.1; D=40.03
Control Arm-/Trailing Arm Bush	E 320		<b>F8-5327</b>	d=11; D=36
Mounting, axle beam	E 200 , E 220		<b>F8-5420</b>	d=16; D=51; Thick. [mm]=58
Top Strut Mounting	E 320		<b>F8-5502</b>	d=14.5; D=59; Thick. [mm]=130
Control Arm-/Trailing Arm Bush	All Models		<b>F8-5678</b>	H=58; d=12; D=33
Mounting, axle beam	All Models		<b>F8-5744</b>	
Repair Set, axle beam	E 320 , E 36 AMG		<b>F8-5820</b>	
Mounting, axle beam	E 320 , E 36 AMG		<b>F8-5821</b>	H=59; d=16; D=66
Rubber Buffer, suspension	All Models		<b>F8-5901</b>	
Rubber Buffer, suspension	All Models		<b>F8-5914</b>	H=75
Rubber Buffer, suspension	All Models		<b>F8-5918</b>	
Repair Set, axle beam	E 200 , E 220 , E 320	with fastening material	<b>F8-6230</b>	
Mounting, manual transmission	All Models		<b>F8-6498</b>	
Control Arm-/Trailing Arm Bush	All Models		<b>G9-503</b>	H=43; d=12; D=31
Control Arm-/Trailing Arm Bush	All Models		<b>G9-651</b>	d=12
Control Arm-/Trailing Arm Bush	All Models		<b>G9-652</b>	d=13
<b>E-CLASS Coupe (C124)</b>			<b>06/1993 → 06/1997</b>	
Dust Cover Kit, shock absorber	E 200 , E 220 , E 320		<b>AK-735019</b>	
Repair Kit, reversing lever	E 200 , E 220 , E 320 , E 36 AMG		<b>F7-9001</b>	
Mounting, propshaft	E 200		<b>F8-4002</b>	H=89; d=43; D=83; T [mm]=119
Mounting, propshaft	E 200		<b>F8-4003</b>	H=100; d=50; D=93; T [mm]=119
Control Arm-/Trailing Arm Bush	E 200 , E 220 , E 320 , E 36 AMG		<b>F8-5010</b>	H=49; d=16; D1=49; D2=65
Suspension Kit	E 200	<b>SP</b>	<b>F8-5011</b>	
Mounting, axle beam	E 200 , E 220		<b>F8-5018</b>	H=58; D1=68; D2=81
Suspension Kit	E 200 , E 220 , E 320 , E 36 AMG	ch.C017669→; <b>SP</b>	<b>F8-5195</b>	
Stabiliser Mounting	E 200 , E 220 , E 320		<b>F8-5214</b>	d=18
Stabiliser Mounting	E 200 , E 220 , E 320 , E 36 AMG		<b>F8-5216</b>	d=28.5





**Article Description****Article Nr.****Fitting Position**

<b>E-CLASS Coupe (C124)</b>			<b>06/1993 → 06/1997</b>		
Stabiliser Mounting	E 200 , E 220 , E 320 , E 36 AMG		<b>F8-5217</b>		d=26.5
Stabiliser Mounting	E 200 , E 220		<b>F8-5236</b>		H=38; d=24; D=45
Control Arm-/Trailing Arm Bush	E 200 , E 220 , E 320 , E 36 AMG		<b>F8-5297</b>		H=48; d=14.1; D=40.03
Control Arm-/Trailing Arm Bush	E 200 , E 220 , E 320 , E 36 AMG		<b>F8-5327</b>		d=11; D=36
Mounting, axle beam	E 200 , E 220		<b>F8-5420</b>		d=16; D=51; Thick. [mm]=58
Engine Mounting	E 320		<b>F8-5449</b>		
Top Strut Mounting	E 200 , E 220 , E 320 , E 36 AMG		<b>F8-5502</b>		d=14.5; D=59; Thick. [mm]=130
Control Arm-/Trailing Arm Bush	E 200 , E 220 , E 320 , E 36 AMG		<b>F8-5678</b>		H=58; d=12; D=33
Mounting, axle beam	E 200 , E 220 , E 320 , E 36 AMG		<b>F8-5744</b>		
Repair Set, axle beam	E 320 , E 36 AMG		<b>F8-5820</b>		
Mounting, axle beam	E 320 , E 36 AMG		<b>F8-5821</b>		H=59; d=16; D=66
Rubber Buffer, suspension	E 200 , E 220 , E 320 , E 36 AMG		<b>F8-5901</b>		
Rubber Buffer, suspension	All Models		<b>F8-5914</b>		H=75
Rubber Buffer, suspension	All Models		<b>F8-5918</b>		
Stabiliser Mounting	E 200 , E 220		<b>F8-5973</b>		H=38,5; d=25; D=45
Repair Set, axle beam	E 200 , E 220 , E 320	with fastening material	<b>F8-6230</b>		
Joint, propshaft	E 320	with fastening material	<b>F8-6239</b>		Bolt Hole Circle Ø [mm]=100; d=46; D=140; W=29.8
Control Arm-/Trailing Arm Bush	E 200 , E 220 , E 320 , E 36 AMG		<b>F8-6468</b>		H=48; d=16; D=49
Suspension Kit	E 200 , E 220 , E 320 , E 36 AMG		<b>F8-6473</b>		
Mounting, manual transmission	E 200 , E 220 , E 320 , E 36 AMG		<b>F8-6498</b>		
Joint, propshaft	E 200 , E 220	with add-on material	<b>F8-7130</b>		Bolt Hole Circle Ø [mm]=90
Control Arm-/Trailing Arm Bush	All Models		<b>G9-503</b>		H=43; d=12; D=31
Control Arm-/Trailing Arm Bush	All Models		<b>G9-651</b>		d=12
Control Arm-/Trailing Arm Bush	All Models		<b>G9-652</b>		d=13
<b>E-CLASS Estate (S124)</b>			<b>06/1993 → 06/1996</b>		
Dust Cover Kit, shock absorber	E 200 T , E 220 T , E 250 T D , E 280 T , E 300 T D , E 300 T Turbo-D , E 320 T		<b>AK-735019</b>		
Repair Kit, reversing lever	E 200 T , E 220 T , E 250 T D , E 280 T , E 300 T D , E 300 T Turbo-D , E 36 T AMG		<b>F7-9001</b>		
Mounting, propshaft	E 200 T , E 250 T D		<b>F8-4002</b>		H=89; d=43; D=83; T [mm]=119
Mounting, propshaft	E 200 T , E 250 T D		<b>F8-4003</b>		H=100; d=50; D=93; T [mm]=119

<b>AK-735019</b>	<b>F7-9001</b>	<b>F8-4002</b>	<b>F8-4003</b>	<b>F8-5005</b>	<b>F8-5217</b>	<b>F8-5236</b>
Ref.Nr.: 1293230192	Ref.Nr.: 1234600050	Ref.Nr.: 1244100181	Ref.Nr.: 1244100281	Ref.Nr.: 1242400317	Ref.Nr.: 1243235685	Ref.Nr.: 1243235485
<b>F8-5297</b>	<b>F8-5327</b>	<b>F8-5420</b>	<b>F8-5449</b>	<b>F8-5502</b>	<b>F8-5678</b>	<b>F8-5744</b>
Ref.Nr.: 2043520027	Ref.Nr.: 1243523565	Ref.Nr.: 2013513642	Ref.Nr.: 2012404117	Ref.Nr.: A1243201444	Ref.Nr.: 1293520065	Ref.Nr.: 1243511342
<b>F8-5820</b>	<b>F8-5821</b>	<b>F8-5901</b>	<b>F8-5914</b>	<b>F8-5918</b>	<b>F8-5973</b>	<b>F8-6230</b>
Ref.Nr.: 1243508608	Ref.Nr.: 1293511542	Ref.Nr.: 2013232044	Ref.Nr.: 1293230744	Ref.Nr.: 1243230744	Ref.Nr.: 1243234485	Ref.Nr.: 1243516408

Article Description

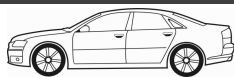

Article Nr.

Fitting Position



<b>E-CLASS Estate (S124)</b>			<b>06/1993 → 06/1996</b>		
Engine Mounting	E 250 T D		<b>F8-5005</b>		H=111; D1=90; D2=103
Suspension Kit	E 300 T Turbo-D	ch.→F204091	<b>F8-5009</b>		
Control Arm-/Trailing Arm Bush	E 200 T , E 220 T , E 250 T D , E 280 T , E 300 T D , E 300 T Turbo-D , E 36 T AMG		<b>F8-5010</b>		H=49; d=16; D1=49; D2=65
Mounting, axle beam	E 200 T , E 220 T , E 250 T D , E 300 T D , E 300 T Turbo-D		<b>F8-5018</b>		H=58; D1=68; D2=81
Suspension Kit	E 300 T Turbo-D		<b>F8-5195</b>		
Stabiliser Mounting	E 200 T , E 220 T , E 280 T , E 300 T Turbo-D , E 320 T		<b>F8-5209</b>		H=36; d=22.5; D=38
Stabiliser Mounting	E 300 T D	07/1993 →	<b>F8-5209</b>		H=36; d=22.5; D=38
Stabiliser Mounting	E 200 T , E 220 T , E 250 T D , E 280 T , E 300 T D , E 300 T Turbo-D , E 320 T , E 36 T AMG		<b>F8-5216</b>		d=28.5
Control Arm-/Trailing Arm Bush	E 200 T , E 220 T , E 250 T D , E 280 T , E 300 T 4-matic , E 300 T D , E 300 T Turbo-D , E 300 T Turbo-D 4-matic , E 320 T , E 36 T AMG		<b>F8-5297</b>		H=48; d=14.1; D=40.03
Control Arm-/Trailing Arm Bush	E 200 T , E 220 T , E 250 T D , E 280 T , E 300 T D , E 300 T Turbo-D , E 300 T Turbo-D 4-matic , E 320 T , E 36 T AMG		<b>F8-5327</b>		d=11; D=36
Engine Mounting	E 250 T D		<b>F8-5449</b>		
Engine Mounting	E 280 T , E 300 T D , E 320 T		<b>F8-5449</b>		
Engine Mounting	E 300 T Turbo-D		<b>F8-5449</b>		
Top Strut Mounting	E 280 T , E 320 T		<b>F8-5502</b>		d=14.5; D=59; Thick. [mm]=130
Control Arm-/Trailing Arm Bush	E 200 T , E 220 T , E 250 T D , E 250 Turbo D , E 280 T , E 300 T D , E 300 T Turbo-D , E 300 T Turbo-D 4-matic , E 320 T , E 36 T AMG		<b>F8-5678</b>		H=58; d=12; D=33
Mounting, axle beam	E 300 T Turbo-D 4-matic		<b>F8-5733</b>		H=30; d=14; D=47
Mounting, axle beam	E 200 T , E 220 T , E 250 T D , E 250 Turbo D , E 280 T , E 300 T D , E 300 T Turbo-D , E 300 T Turbo-D 4-matic , E 320 T , E 36 T AMG		<b>F8-5744</b>		
Mounting, axle beam	E 300 T Turbo-D 4-matic		<b>F8-5773</b>		H=70; D=70
Rubber Buffer, suspension	All Models		<b>F8-5901</b>		
Rubber Buffer, suspension	E 300 TE-24 AMG		<b>F8-5914</b>		H=75
Rubber Buffer, suspension	E 200 T , E 220 T , E 250 T D , E 250 Turbo D , E 280 T , E 300 T D , E 300 T Turbo-D , E 300 TE-24 AMG , E 320 T , E 36 T AMG		<b>F8-5918</b>		
Stabiliser Mounting	E 200 T , E 220 T		<b>F8-5973</b>		H=38,5; d=25; D=45
Repair Set, axle beam	E 200 T , E 220 T , E 250 T D , E 280 T , E 300 T D , E 300 T Turbo-D , E 300 T Turbo-D 4-matic , E 320 T	with fastening material	<b>F8-6230</b>		
Joint, propshaft	E 280 T	with fastening material;	<b>F8-6239</b>		Bolt Hole Circle Ø [mm]=100; d=46; D=140; W=29.8
Joint, propshaft	E 320 T , E 36 T AMG	with fastening material	<b>F8-6239</b>		Bolt Hole Circle Ø [mm]=100; d=46; D=140; W=29.8

<b>F8-5005</b>	<b>F8-5009</b>	<b>F8-5010</b>	<b>F8-5018</b>	<b>F8-5195</b>	<b>F8-5209</b>	<b>F8-5216</b>
Ref.Nr.: 1242400317	Ref.Nr.: 1243300275	Ref.Nr.: 2013335114	Ref.Nr.: 2013512742	Ref.Nr.: 1243300675	Ref.Nr.: 1243235085	Ref.Nr.: 1243232885
<b>F8-5297</b>	<b>F8-5327</b>	<b>F8-5449</b>	<b>F8-5502</b>	<b>F8-5678</b>	<b>F8-5733</b>	<b>F8-5744</b>
Ref.Nr.: 2043520027	Ref.Nr.: 1243523565	Ref.Nr.: 2012404117	Ref.Nr.: A1243201444	Ref.Nr.: 1293520065	Ref.Nr.: 1243524165	Ref.Nr.: 1243511342
<b>F8-5773</b>	<b>F8-5901</b>	<b>F8-5914</b>	<b>F8-5918</b>	<b>F8-5973</b>	<b>F8-6230</b>	<b>F8-6239</b>
Ref.Nr.: 1243510242	Ref.Nr.: 2013232044	Ref.Nr.: 1293230744	Ref.Nr.: 1243230744	Ref.Nr.: 1243234485	Ref.Nr.: 1243516408	Ref.Nr.: 1704100015

**Article Description****Article Nr.****Fitting Position**

<b>E-CLASS Estate (S124)</b>			<b>06/1993 → 06/1996</b>		
Mounting, manual transmission	E 200 T, E 220 T, E 250 T D, E 250 Turbo D, E 280 T, E 300 T D, E 300 T Turbo-D, E 300 T Turbo-D 4-matic, E 320 T, E 36 T AMG		<b>F8-6498</b>		
Joint, propshaft	E 200 T, E 220 T, E 250 T D, E 300 T D	with add-on material	<b>F8-7130</b>		Bolt Hole Circle Ø [mm]=90
Control Arm-/Trailing Arm Bush	All Models		<b>G9-503</b>		H=43; d=12; D=31
Control Arm-/Trailing Arm Bush	All Models		<b>G9-651</b>		d=12
Control Arm-/Trailing Arm Bush	All Models		<b>G9-652</b>		d=13
<b>E-CLASS (W210)</b>			<b>06/1995 → 03/2002</b>		
Alternator Freewheel Clutch	E 200 D, E 220 D, E 250 D, E 290 Turbo-D, E 300 D, E 300 Turbo-D		<b>F5-1003</b>		
Alternator Freewheel Clutch	E 200 CDI, E 220 CDI, E 270 CDI		<b>F5-1017</b>		
Alternator Freewheel Clutch	E 200 CDI, E 220 CDI, E 270 CDI, E 320 CDI		<b>F5-1018</b>		
Alternator Freewheel Clutch	E 270 CDI		<b>F5-1019</b>		
Engine Mounting	E 290 Turbo-D		<b>F8-5007</b>		
Suspension Kit	E 200, E 200 CDI, E 200 D, E 200 Kompressor, E 220 CDI, E 220 D, E 230, E 250 D, E 250 Turbo-D, E 280, E 290 Turbo-D, E 300 D, E 300 Turbo-D, E 320, E 420, E 430, E 55 AMG		<b>F8-5198</b>		
Stabiliser Mounting	E 200, E 200 CDI, E 200 D, E 200 Kompressor, E 220 CDI, E 220 D, E 230, E 240, E 250 D, E 250 Turbo-D, E 270 CDI, E 280, E 290 Turbo-D, E 300 Turbo-D, E 320, E 320 CDI, E 430		<b>F8-5210</b>		d=26.5
Stabiliser Mounting	E 280 4-matic, E 320 4-matic		<b>F8-5214</b>		d=18
Stabiliser Mounting	E 280 4-matic, E 320 4-matic		<b>F8-5222</b>		d=30
Stabiliser Mounting	E 200, E 200 D, E 220 D, E 230, E 250 D, E 280, E 290 Turbo-D, E 300 D, E 320, E 420, E 50 AMG	ch.→A394035; 5, 8	<b>F8-5231</b>		d=27; D=65; W=46
Control Arm-/Trailing Arm Bush	E 200, E 200 CDI, E 200 D, E 200 Kompressor, E 220 CDI, E 220 D, E 230, E 240, E 250 D, E 250 Turbo-D, E 270 CDI, E 280, E 280 4-matic, E 290 Turbo-D, E 300 D, E 300 Turbo-D, E 320, E 320 4-matic, E 320 CDI, E 420, E 430, E 430 4-matic		<b>F8-5297</b>		H=48; d=14.1; D=40.03
Mounting, manual transmission	E 200 Kompressor, E 240, E 280		<b>F8-5308</b>		H=75; L=110
Control Arm-/Trailing Arm Bush	E 200, E 200 CDI, E 200 D, E 200 Kompressor, E 220 CDI, E 220 D, E 230, E 250 D, E 250 Turbo-D, E 280, E 290 Turbo-D, E 300 D, E 300 Turbo-D, E 320, E 420, E 430, E 55 AMG		<b>F8-5309</b>		H=47; d=20; D=70
Control Arm-/Trailing Arm Bush	E 200, E 200 CDI, E 200 D, E 200 Kompressor, E 220 CDI, E 220 D, E 230, E 240, E 250 D, E 250 Turbo-D, E 270 CDI, E 280, E 280 4-matic, E 290 Turbo-D, E 300 D, E 300 Turbo-D, E 320, E 320 4-matic, E 320 CDI, E 420, E 430, E 430 4-matic		<b>F8-5327</b>		d=11; D=36

<b>F5-1003</b>	<b>F5-1017</b>	<b>F5-1018</b>	<b>F5-1019</b>	<b>F8-5007</b>	<b>F8-5198</b>	<b>F8-5210</b>
Ref.Nr.: 6041500060	Ref.Nr.: 6111500160	Ref.Nr.: 6111500360	Ref.Nr.: 5117591AA	Ref.Nr.: 2102401317	Ref.Nr.: 2103300475	Ref.Nr.: 2103231485
<b>F8-5214</b>	<b>F8-5222</b>	<b>F8-5231</b>	<b>F8-5297</b>	<b>F8-5308</b>	<b>F8-5309</b>	<b>F8-5327</b>
Ref.Nr.: 1243234985	Ref.Nr.: 1293230185	Ref.Nr.: 1403231985	Ref.Nr.: 2043520027	Ref.Nr.: 2102400418	Ref.Nr.: 2103335514	Ref.Nr.: 1243523565
<b>F8-5458</b>	<b>F8-6498</b>	<b>F8-7130</b>	<b>G9-503</b>	<b>G9-651</b>	<b>G9-652</b>	
Ref.Nr.: 2022402917	Ref.Nr.: 1242400018	Ref.Nr.: 1264100515	Ref.Nr.: 1243524365	Ref.Nr.: 1243529065	Ref.Nr.: 1243528665	

Article Description



Article Nr.

Fitting Position



## E-CLASS (W210)

06/1995 → 03/2002

Engine Mounting	E 300 D , E 300 Turbo-D		<b>F8-5458</b>		
Engine Mounting	E 300 D , E 320 CDI		<b>F8-5459</b>		
Engine Mounting	E 200 , E 200 D , E 220 D , E 230		<b>F8-5460</b>		
Belt Pulley, crankshaft	E 200 , E 200 CDI , E 200 D , E 200 Kompressor , E 220 CDI , E 220 D , E 230 , E 240 , E 250 D , E 250 Turbo-D , E 270 CDI , E 280 , E 280 4-matic , E 290 Turbo-D , E 300 D , E 300 Turbo-D , E 320 , E 320 4-matic , E 320 CDI , E 420 , E 430 , E 430 4-matic	Parameter: 6PK	<b>F8-5663</b>		d=32; D1=160; D2=157; W1=82
Control Arm-/Trailing Arm Bush	E 200 , E 220 D , E 230 , E 240 , E 250 D , E 280 , E 290 Turbo-D , E 300 D , E 300 Turbo-D , E 320 , E 320 4-matic , E 420 , E 430 , E 50 AMG , E 55 AMG		<b>F8-5678</b>		H=58; d=12; D=33
Mounting, axle beam	E 200 D , E 220 D , E 250 D , E 250 Turbo-D , E 280 , E 280 4-matic , E 290 Turbo-D , E 300 D , E 300 Turbo-D , E 320 , E 320 4-matic , E 420 , E 430 , E 50 AMG , E 55 AMG		<b>F8-5826</b>		
Repair Set, axle beam	E 200 D , E 220 D , E 250 D , E 250 Turbo-D , E 280 , E 280 4-matic , E 290 Turbo-D , E 300 D , E 300 Turbo-D , E 320 , E 320 4-matic , E 420 , E 430 , E 50 AMG , E 55 AMG		<b>F8-5827</b>		
Control Arm-/Trailing Arm Bush	E 200 , E 200 CDI , E 200 D , E 200 Kompressor , E 220 CDI , E 220 D , E 230 , E 240 , E 250 D , E 250 Turbo-D , E 270 CDI , E 280 , E 280 4-matic , E 290 Turbo-D , E 300 D , E 300 Turbo-D , E 320 , E 320 4-matic , E 320 CDI , E 420 , E 430 , E 430 4-matic		<b>F8-5872</b>		H1=60; H2=40; d=12; D=40
Mounting, axle beam	E 200 , E 200 CDI , E 200 D , E 200 Kompressor , E 220 CDI , E 220 D , E 230 , E 240 , E 250 D , E 250 Turbo-D , E 270 CDI , E 280 , E 280 4-matic , E 290 Turbo-D , E 300 D , E 300 Turbo-D , E 320 , E 320 4-matic , E 320 CDI , E 420 , E 430 , E 430 4-matic		<b>F8-5873</b>		H=29; d=15; D=66
Mounting, axle beam	E 200 D , E 220 D , E 240 , E 250 D , E 250 Turbo-D , E 280 , E 280 4-matic , E 290 Turbo-D , E 300 D , E 300 Turbo-D , E 320 , E 320 4-matic , E 420 , E 430 , E 50 AMG , E 55 AMG		<b>F8-5916</b>		
Repair Set, axle beam	E 200 D , E 220 D , E 240 , E 250 D , E 250 Turbo-D , E 280 , E 280 4-matic , E 290 Turbo-D , E 300 D , E 300 Turbo-D , E 320 , E 320 4-matic , E 420 , E 430 , E 50 AMG , E 55 AMG		<b>F8-5917</b>		
Joint, propshaft	E 280 , E 280 4-matic , E 290 Turbo-D , E 320 , E 320 4-matic	with fastening material	<b>F8-6239</b>		Bolt Hole Circle Ø [mm]=100; d=46; D=140; W=29.8
Joint, propshaft	E 280 , E 290 Turbo-D , E 320	with fastening material;	<b>F8-6239</b>		Bolt Hole Circle Ø [mm]=100; d=46; D=140; W=29.8
Joint, propshaft	E 280 , E 320	ch.→A408865; with fastening material	<b>F8-6239</b>		Bolt Hole Circle Ø [mm]=100; d=46; D=140; W=29.8
Joint, propshaft	E 280 , E 320	ch.→A408865; with fastening material;	<b>F8-6239</b>		Bolt Hole Circle Ø [mm]=100; d=46; D=140; W=29.8

<b>F8-5458</b>	<b>F8-5459</b>	<b>F8-5460</b>	<b>F8-5663</b>	<b>F8-5678</b>	<b>F8-5826</b>	<b>F8-5827</b>
Ref.Nr.: 2022402917	Ref.Nr.: 2102400717	Ref.Nr.: 2022401717	Ref.Nr.: 1120350800	Ref.Nr.: 1293520065	Ref.Nr.: 2103510542	Ref.Nr.: 2103505908
<b>F8-5872</b>	<b>F8-5873</b>	<b>F8-5916</b>	<b>F8-5917</b>	<b>F8-6239</b>	<b>F8-6466</b>	
Ref.Nr.: 5131.53	Ref.Nr.: 1293512142	Ref.Nr.: 2103510842	Ref.Nr.: 2103505808	Ref.Nr.: 1704100015	Ref.Nr.: 210 325 03 84	



Article Description



Article Nr.

Fitting Position



<b>E-CLASS (W210)</b>		<b>06/1995 → 03/2002</b>	
Rubber Buffer, suspension	E 200 , E 200 CDI , E 200 D , E 200 Kompressor , E 220 CDI , E 220 D , E 230 , E 240 , E 250 D , E 250 Turbo-D , E 270 CDI , E 280 , E 280 4-matic , E 290 Turbo-D , E 300 D , E 300 Turbo-D , E 320 , E 320 4-matic , E 320 CDI , E 420 , E 430 , E 430 4-matic	<b>F8-6466</b>	
Control Arm-/Trailing Arm Bush	E 200 , E 200 CDI , E 200 D , E 200 Kompressor , E 220 CDI , E 220 D , E 230 , E 240 , E 250 D , E 250 Turbo-D , E 270 CDI , E 280 , E 290 Turbo-D , E 300 D , E 300 Turbo-D , E 320 , E 320 CDI , E 420 , E 430 , E 50 AMG , E 55 AMG , E 55 AMG 4-matic	<b>F8-6813</b>	⊕ ⊕ H=99; d=10; W=48
Engine Mounting	E 200 , E 220 D , E 230 , E 250 D , E 290 Turbo-D , E 300 D	ch.→A177063, J024801;  4-speed	<b>F8-6924</b>
Engine Mounting	E 280	ch.→A177063, J024801;  4-speed,  5-speed	<b>F8-6924</b>
Engine Mounting	E 320	5-speed	<b>F8-6924</b>
Engine Mounting	E 200 CDI , E 220 CDI	Aluminium; not for  5-speed	<b>F8-7747</b>
Engine Mounting	E 200 Kompressor , E 300 Turbo-D , E 55 AMG	Aluminium;	<b>F8-7747</b>
Engine Mounting	E 250 D , E 290 Turbo-D	ch.A177064, J024802→; Aluminium;	<b>F8-7747</b>
Engine Mounting	E 270 CDI , E 320 CDI , E 430	Aluminium	<b>F8-7747</b>
Engine Mounting	E 420 , E 50 AMG	ch.A313879→; ; Aluminium;	<b>F8-7747</b>
Engine Mounting	E 200 CDI , E 220 CDI	ch.A962232, X027614→	<b>F8-8175</b> ⊕ ⊕
Engine Mounting	E 200 Kompressor , E 270 CDI , E 320 4-matic		<b>F8-8175</b> ⊕ ⊕
Engine Mounting	E 200 Kompressor , E 270 CDI , E 320 4-matic		<b>F8-8175</b> ⊕
Engine Mounting	E 200 Kompressor , E 270 CDI , E 320 4-matic		<b>F8-8175</b> ⊕
Engine Mounting	E 280 4-matic	for OE: 2032401317, 2102401617, 2102402717, 2102402817, 2112400317, A2032401317, A2102401617, A2102402717, A2102402817, A2112400317	<b>F8-8175</b> ⊕
Mounting, manual transmission	E 200 , E 200 Kompressor , E 220 D , E 230 , E 250 D , E 250 Turbo-D , E 280 , E 290 Turbo-D , E 300 D		<b>F8-8178</b>
Control Arm-/Trailing Arm Bush	E 200 , E 200 CDI , E 200 D , E 200 Kompressor , E 220 CDI , E 220 D , E 230 , E 240 , E 250 D , E 250 Turbo-D , E 270 CDI , E 280 , E 280 4-matic , E 290 Turbo-D , E 300 D , E 300 Turbo-D , E 320 , E 320 4-matic , E 320 CDI , E 420 , E 430 , E 430 4-matic	<b>G9-503</b>	⊕ ⊕ H=43; d=12; D=31
Control Arm-/Trailing Arm Bush	E 200 , E 200 CDI , E 200 D , E 200 Kompressor , E 220 CDI , E 220 D , E 230 , E 240 , E 250 D , E 250 Turbo-D , E 270 CDI , E 280 , E 280 4-matic , E 290 Turbo-D , E 300 D , E 300 Turbo-D , E 320 , E 320 4-matic , E 320 CDI , E 420 , E 430 , E 430 4-matic	<b>G9-651</b>	⊕ ⊕ d=12

<b>F8-6466</b>	<b>F8-6813</b>	<b>F8-6924</b>	<b>F8-7747</b>	<b>F8-8175</b>	<b>F8-8178</b>	<b>G9-503</b>
Ref.Nr.: 210 325 03 84	Ref.Nr.: 2023337714	Ref.Nr.: 2022400518	Ref.Nr.: 1402401218	Ref.Nr.: 2112400317	Ref.Nr.: 2022400218	Ref.Nr.: 1243524365
<b>G9-651</b>	<b>G9-652</b>					
Ref.Nr.: 1243529065	Ref.Nr.: 1243528665					

Article Description



Article Nr.

Fitting Position



<b>E-CLASS (W210)</b>		<b>06/1995 → 03/2002</b>	
Control Arm-/Trailing Arm Bush	E 200, E 200 CDI, E 200 D, E 200 Kompressor, E 220 CDI, E 220 D, E 230, E 240, E 250 D, E 250 Turbo-D, E 270 CDI, E 280, E 280 4-matic, E 290 Turbo-D, E 300 D, E 300 Turbo-D, E 320, E 320 4-matic, E 320 CDI, E 420, E 430, E 430 4-matic	<b>G9-652</b>	d=13
<b>E-CLASS Estate (S210)</b>		<b>06/1996 → 03/2003</b>	
Alternator Freewheel Clutch	E 250 T D, E 290 T Turbo-D, E 300 T Turbo-D	<b>F5-1003</b>	
Alternator Freewheel Clutch	E 220 T CDI, E 270 T CDI	<b>F5-1017</b>	
Alternator Freewheel Clutch	E 220 T CDI, E 270 T CDI, E 320 T CDI	<b>F5-1018</b>	
Alternator Freewheel Clutch	E 270 T CDI	<b>F5-1019</b>	
Engine Mounting	E 290 T Turbo-D	<b>F8-5007</b>	
Suspension Kit	E 200 T, E 200 T Kompressor, E 220 T CDI, E 230 T, E 250 T D, E 250 T Turbo-D, E 280 T, E 290 T Turbo-D, E 300 T Turbo-D, E 320 T, E 420 T, E 430 T, E 55 T AMG	<b>F8-5198</b>	
Stabiliser Mounting	E 280 T 4-matic, E 320 T 4-matic	<b>F8-5214</b>	d=18
Stabiliser Mounting	E 280 T 4-matic, E 320 T 4-matic	<b>F8-5222</b>	d=30
Stabiliser Mounting	E 200 T, E 250 T D, E 290 T Turbo-D, E 300 T Turbo-D, E 320 T, E 420 T	<b>F8-5231</b>	d=27; D=65; W=46
Control Arm-/Trailing Arm Bush	E 200 T, E 200 T Kompressor, E 220 T CDI, E 230 T, E 240 T, E 250 T D, E 250 T Turbo-D, E 270 T CDI, E 280 T, E 280 T 4-matic, E 290 T Turbo-D, E 300 T Turbo-D, E 320 T, E 320 T 4-matic, E 320 T CDI, E 420 T, E 430 T, E 430 T 4-matic, E	<b>F8-5297</b>	H=48; d=14.1; D=40.03
Mounting, manual transmission	E 240 T, E 280 T	<b>F8-5308</b>	H=75; L=110
Control Arm-/Trailing Arm Bush	E 200 T, E 200 T Kompressor, E 220 T CDI, E 230 T, E 250 T D, E 250 T Turbo-D, E 280 T, E 290 T Turbo-D, E 300 T Turbo-D, E 320 T, E 420 T, E 430 T, E 55 T AMG	<b>F8-5309</b>	H=47; d=20; D=70
Control Arm-/Trailing Arm Bush	E 200 T, E 200 T Kompressor, E 220 T CDI, E 230 T, E 240 T, E 250 T D, E 250 T Turbo-D, E 270 T CDI, E 280 T, E 280 T 4-matic, E 290 T Turbo-D, E 300 T Turbo-D, E 320 T, E 320 T 4-matic, E 320 T CDI, E 420 T, E 430 T, E 430 T 4-matic, E	<b>F8-5327</b>	d=11; D=36
Engine Mounting	E 300 T Turbo-D	<b>F8-5458</b>	
Engine Mounting	E 300 T Turbo-D, E 320 T CDI	<b>F8-5459</b>	
Engine Mounting	E 200 T, E 230 T	<b>F8-5460</b>	
Belt Pulley, crankshaft	E 240 T, E 280 T, E 280 T 4-matic, E 320 T, E 320 T 4-matic, E 430 T, E 430 T 4-matic, E 55 T AMG 4-matic	Parameter: 6PK <b>F8-5663</b>	d=32; D1=160; D2=157; W1=82
Control Arm-/Trailing Arm Bush	E 200 T, E 200 T Kompressor, E 220 T CDI, E 230 T, E 240 T, E 250 T D, E 250 T Turbo-D, E 280 T 4-matic, E 290 T Turbo-D, E 300 T Turbo-D, E 320 T, E 320 T 4-matic, E 420 T, E 430 T, E 430 T 4-matic, E 55 T AMG	<b>F8-5678</b>	H=58; d=12; D=33





Article Description



Article Nr.

Fitting Position



<b>E-CLASS Estate (S210)</b>		<b>06/1996 → 03/2003</b>	
Mounting, axle beam	E 200 T Kompressor , E 250 T D , E 250 T Turbo-D , E 280 T 4-matic , E 290 T Turbo-D , E 320 T , E 320 T 4-matic , E 420 T , E 430 T		<b>F8-5826</b>
Repair Set, axle beam	E 200 T Kompressor , E 250 T D , E 250 T Turbo-D , E 280 T 4-matic , E 290 T Turbo-D , E 320 T , E 320 T 4-matic , E 420 T , E 430 T		<b>F8-5827</b>
Control Arm-/Trailing Arm Bush	E 200 T , E 200 T Kompressor , E 220 T CDI , E 230 T , E 240 T , E 250 T D , E 250 T Turbo-D , E 270 T CDI , E 280 T , E 280 T 4-matic , E 290 T Turbo-D , E 300 T Turbo-D , E 320 T , E 320 T 4-matic , E 320 T CDI , E 420 T , E 430 T , E 430 T 4-matic , E		<b>F8-5872</b>
Mounting, axle beam	E 200 T , E 200 T Kompressor , E 220 T CDI , E 230 T , E 240 T , E 250 T D , E 250 T Turbo-D , E 270 T CDI , E 280 T , E 280 T 4-matic , E 290 T Turbo-D , E 300 T Turbo-D , E 320 T , E 320 T 4-matic , E 320 T CDI , E 420 T , E 430 T , E 430 T 4-matic , E		<b>F8-5873</b>
Mounting, axle beam	E 200 T Kompressor , E 250 T D , E 250 T Turbo-D , E 280 T 4-matic , E 290 T Turbo-D , E 320 T , E 320 T 4-matic , E 420 T , E 430 T		<b>F8-5916</b>
Repair Set, axle beam	E 200 T Kompressor , E 250 T D , E 250 T Turbo-D , E 280 T 4-matic , E 290 T Turbo-D , E 320 T , E 320 T 4-matic , E 420 T , E 430 T		<b>F8-5917</b>
Joint, propshaft	E 280 T 4-matic , E 320 T 4-matic	with fastening material	<b>F8-6239</b>
Joint, propshaft	E 290 T Turbo-D	with fastening material; Type: 210.217	<b>F8-6239</b>
Joint, propshaft	E 290 T Turbo-D	with fastening material;	<b>F8-6239</b>
Joint, propshaft	E 320 T	ch.→A408865; with fastening material	<b>F8-6239</b>
Rubber Buffer, suspension	E 200 T , E 200 T Kompressor , E 220 T CDI , E 230 T , E 240 T , E 250 T D , E 250 T Turbo-D , E 270 T CDI , E 280 T , E 280 T 4-matic , E 290 T Turbo-D , E 300 T Turbo-D , E 320 T , E 320 T 4-matic , E 320 T CDI , E 420 T , E 430 T , E 430 T 4-matic , E		<b>F8-6466</b>
Control Arm-/Trailing Arm Bush	E 200 T , E 200 T Kompressor , E 220 T CDI , E 230 T , E 240 T , E 250 T D , E 250 T Turbo-D , E 270 T CDI , E 280 T , E 290 T Turbo-D , E 300 T Turbo-D , E 320 T , E 320 T CDI , E 420 T , E 430 T , E 55 T AMG , E 55 T AMG 4-matic		<b>F8-6813</b>
Engine Mounting	E 200 T Kompressor , E 250 T Turbo-D , E 300 T Turbo-D , E 430 T , E 55 T AMG	Aluminium;	<b>F8-7747</b>
Engine Mounting	E 220 T CDI	Aluminium; not for  5-speed	<b>F8-7747</b>
Engine Mounting	E 270 T CDI , E 320 T CDI	Aluminium	<b>F8-7747</b>
Engine Mounting	E 420 T	ch.A2630031→; ; Aluminium;	<b>F8-7747</b>
Engine Mounting	E 200 T Kompressor , E 270 T CDI		<b>F8-8175</b>

<b>F8-5826</b>	<b>F8-5827</b>	<b>F8-5872</b>	<b>F8-5873</b>	<b>F8-5916</b>	<b>F8-5917</b>	<b>F8-6239</b>
Ref.Nr.: 2103510542	Ref.Nr.: 2103505908	Ref.Nr.: 5131.53	Ref.Nr.: 1293512142	Ref.Nr.: 2103510842	Ref.Nr.: 2103505808	Ref.Nr.: 1704100015
<b>F8-6466</b>	<b>F8-6813</b>	<b>F8-7747</b>	<b>F8-8175</b>			
Ref.Nr.: 210 325 03 84	Ref.Nr.: 2023337714	Ref.Nr.: 1402401218	Ref.Nr.: 2112400317			

Article Description			Article Nr.	Fitting Position	
---------------------	--	--	-------------	------------------	--

**E-CLASS Estate (S210)** 06/1996 → 03/2003

Engine Mounting	E 200 T Kompressor , E 270 T CDI		<b>F8-8175</b>			
Engine Mounting	E 220 T CDI	ch.A962232, X027614→	<b>F8-8175</b>			
Engine Mounting	E 280 T 4-matic , E 320 T 4-matic	for OE: 2032401317, 2102401617, 2102402717, 2102402817, 2112400317, A2032401317, A2102401617, A2102402717, A2102402817, A2112400317	<b>F8-8175</b>			
Mounting, manual transmission	E 200 T , E 200 T Kompressor , E 230 T , E 250 T D , E 250 T Turbo-D , E 290 T Turbo-D		<b>F8-8178</b>			
Control Arm-/Trailing Arm Bush	E 200 T , E 200 T Kompressor , E 220 T CDI , E 230 T , E 240 T , E 250 T D , E 250 T Turbo-D , E 280 T , E 280 T 4-matic , E 290 T Turbo-D , E 300 T Turbo-D , E 320 T , E 320 T 4-matic , E 420 T , E 430 T , E 55 T AMG		<b>G9-503</b>			H=43; d=12; D=31
Control Arm-/Trailing Arm Bush	E 200 T , E 200 T Kompressor , E 220 T CDI , E 230 T , E 240 T , E 250 T D , E 250 T Turbo-D , E 270 T CDI , E 280 T , E 280 T 4-matic , E 290 T Turbo-D , E 300 T Turbo-D , E 320 T , E 320 T 4-matic , E 420 T , E 430 T , E 430 T 4-matic , E		<b>G9-651</b>			d=12
Control Arm-/Trailing Arm Bush	E 200 T , E 200 T Kompressor , E 220 T CDI , E 230 T , E 240 T , E 250 T D , E 250 T Turbo-D , E 280 T , E 280 T 4-matic , E 290 T Turbo-D , E 300 T Turbo-D , E 320 T , E 320 T 4-matic , E 420 T , E 430 T , E 55 T AMG		<b>G9-652</b>			d=13

**E-CLASS (W211)** 03/2002 → 12/2008

Alternator Freewheel Clutch	E 200 CGI, E 200 Kompressor , E200 NGT		<b>F5-1056</b>		
Alternator Freewheel Clutch	E 200 CDI , E 220 CDI , E 270 CDI , E 280 CDI , E 320 CDI		<b>F5-1058</b>		
Alternator Freewheel Clutch	E 280 CDI , E 280 CDI 4-matic, E 300 BlueTEC, E 320 CDI , E 320 CDI 4-matic, E 400 CDI		<b>F5-1065</b>		
Alternator Freewheel Clutch	E 280 CDI , E 300 BlueTEC, E 320 CDI , E 320 CDI 4-matic		<b>F5-1126</b>		
Belt Pulley, crankshaft	E 200 CDI , E 200 CGI, E 200 Kompressor , E 220 CDI , E 240 , E 240 4-matic , E 270 CDI , E 280 , E 280 4-matic , E 280 CDI , E 280 CDI 4-matic, E 320 , E 320 4-matic , E 320 CDI , E 320 CDI 4-matic, E 350 , E 350 4-matic , E 400 CDI , E 420 CDI , E 500 , E 500 4-matic ,	Parameter: 6PK	<b>F8-5663</b>		d=32; D1=160; D2=157; W1=82
Top Strut Mounting	E 200 CDI , E 200 CGI, E 200 Kompressor , E 220 CDI , E 230 , E 240 , E 270 CDI , E 280 , E 280 CDI , E 300 BlueTEC, E 320 , E 320 CDI , E 350 , E 350 CGI , E 400 CDI , E 420 CDI , E 500 , E 500 4-matic , E 55 AMG Kompressor , E 63 AMG , E200 NGT		<b>F8-6059</b>		
Control Arm-/Trailing Arm Bush	E 200 CDI , E 200 Kompressor , E 220 CDI , E 240 , E 270 CDI , E 280 , E 280 CDI , E 320 , E 320 CDI , E 350 , E 350 CGI , E 400 CDI , E 420 CDI , E 500 , E 55 AMG Kompressor		<b>F8-6112</b>		

<b>F5-1056</b>	<b>F5-1058</b>	<b>F5-1065</b>	<b>F5-1126</b>	<b>F8-5663</b>	<b>F8-6059</b>	<b>F8-6112</b>
Ref.Nr.: 2711550016	Ref.Nr.: 6461500260	Ref.Nr.: 6281500060	Ref.Nr.: 05175811AA	Ref.Nr.: 1120350800	Ref.Nr.: 2113200026	Ref.Nr.: 2113332914
<b>F8-6113</b>	<b>F8-8175</b>	<b>F8-8178</b>	<b>G9-503</b>	<b>G9-651</b>	<b>G9-652</b>	
Ref.Nr.: 2113331914	Ref.Nr.: 2112400317	Ref.Nr.: 2022400218	Ref.Nr.: 1243524365	Ref.Nr.: 1243529065	Ref.Nr.: 1243528665	



**Article Description****Article Nr.****Fitting Position**

<b>E-CLASS (W211)</b>		<b>03/2002 → 12/2008</b>		
Control Arm-/Trailing Arm Bush	E 200 CDI , E 200 Kompressor , E 220 CDI , E 230 , E 240 , E 270 CDI , E 280 , E 280 CDI , E 300 BlueTEC , E 320 , E 320 CDI , E 350 , E 350 CGI , E 400 CDI , E 420 CDI , E 500 , E 55 AMG Kompressor , E 63 AMG , E200 NGT		<b>F8-6113</b>	H=56; d=14; D=52
Mounting, axle beam	E 200 CDI , E 200 Kompressor , E 220 CDI , E 240 , E 240 4-matic , E 270 CDI , E 320 , E 320 4-matic , E 320 CDI , E 400 CDI , E 500 , E 500 4-matic , E 55 AMG Kompressor		<b>F8-6119</b>	
Mounting, axle beam	E 200 CDI , E 200 Kompressor , E 220 CDI , E 240 , E 240 4-matic , E 270 CDI , E 320 , E 320 4-matic , E 320 CDI , E 400 CDI , E 500 , E 500 4-matic		<b>F8-6120</b>	
Mounting, axle beam	E 200 CDI , E 200 CGI , E 200 Kompressor , E 220 CDI , E 240 , E 240 4-matic , E 270 CDI , E 280 CDI , E 320 , E 320 4-matic , E 320 CDI , E 400 CDI , E 500 , E 500 4-matic , E 55 AMG Kompressor		<b>F8-6144</b>	
Control Arm-/Trailing Arm Bush	E 200 CDI , E 200 Kompressor , E 220 CDI , E 230 , E 240 , E 240 4-matic , E 270 CDI , E 280 , E 280 CDI , E 280 CDI 4-matic , E 300 BlueTEC , E 320 , E 320 4-matic , E 320 CDI , E 350 , E 350 4-matic , E 350 CGI , E 400 CDI , E 420 CDI , E 500 , E 500 4-ma		<b>F8-6145</b>	d=12.2
Tie Bar Bush	E 200 CDI , E 200 Kompressor , E 220 CDI , E 240 , E 240 4-matic , E 270 CDI , E 320 , E 320 4-matic , E 320 CDI , E 400 CDI , E 500 , E 500 4-matic , E 55 AMG Kompressor		<b>F8-6161</b>	
Mounting, axle beam	E 200 CDI , E 200 CGI , E 200 Kompressor , E 220 CDI , E 230 , E 240 , E 240 4-matic , E 270 CDI , E 280 , E 280 CDI , E 280 CDI 4-matic , E 300 BlueTEC , E 320 , E 320 4-matic , E 320 CDI , E 350 , E 350 4-matic , E 350 CGI , E 400 CDI , E 420 CDI , E 500 ,		<b>F8-6181</b>	
Mounting, axle beam	E 200 CDI , E 200 Kompressor , E 220 CDI , E 240 , E 240 4-matic , E 270 CDI , E 280 , E 280 CDI , E 280 CDI 4-matic , E 320 , E 320 4-matic , E 320 CDI , E 350 , E 350 4-matic , E 350 CGI , E 400 CDI , E 420 CDI , E 500 , E 500 4-matic , E 55 AMG Kompress		<b>F8-6182</b>	H=78; d=12; D=51.5
Mounting, axle beam	E 200 CDI , E 200 CGI , E 200 Kompressor , E 220 CDI , E 230 , E 240 , E 240 4-matic , E 270 CDI , E 280 , E 280 CDI , E 280 CDI 4-matic , E 300 BlueTEC , E 320 , E 320 4-matic , E 320 CDI , E 350 , E 350 4-matic , E 350 CGI , E 400 CDI , E 420 CDI , E 500 ,		<b>F8-6184</b>	
Control Arm-/Trailing Arm Bush	E 200 CDI , E 200 CGI , E 200 Kompressor , E 220 CDI , E 240 , E 270 CDI , E 280 , E 280 CDI , E 320 , E 320 CDI , E 350 , E 400 CDI , E 420 CDI , E 500 , E 55 AMG Kompressor , E 63 AMG , E200 NGT		<b>F8-6651</b>	
Joint, propshaft	E 350 , E 350 4-matic	with fastening material; not for  7-speed	<b>F8-6760</b>	d=57.5; D=145; Thick./Strength 1 [mm]=31.5
Engine Mounting	E 200 Kompressor		<b>F8-6950</b>	
Engine Mounting	E 200 Kompressor		<b>F8-6951</b>	

<b>F8-6113</b>	<b>F8-6119</b>	<b>F8-6120</b>	<b>F8-6144</b>	<b>F8-6145</b>	<b>F8-6161</b>	<b>F8-6181</b>
Ref.Nr.: 2113331914	Ref.Nr.: 2113510642	Ref.Nr.: 2113510842	Ref.Nr.: 2303511442	Ref.Nr.: 2303521565	Ref.Nr.: 2113520865	Ref.Nr.: 2303510242
<b>F8-6182</b>	<b>F8-6184</b>	<b>F8-6651</b>	<b>F8-6760</b>	<b>F8-6950</b>	<b>F8-6951</b>	<b>F8-6968</b>
Ref.Nr.: 2203521365	Ref.Nr.: 2113511442	Ref.Nr.: 2113332214	Ref.Nr.: 0004110200	Ref.Nr.: 2032401917	Ref.Nr.: 2032402017	Ref.Nr.: 2112400017

Article Description			Article Nr.	Fitting Position	
---------------------	--	--	-------------	------------------	--

**E-CLASS (W211)** 03/2002 → 12/2008

Engine Mounting	E 240 4-matic , E 320 4-matic		<b>F8-6968</b>	↺ ↻	
Engine Mounting	E 500 4-matic		<b>F8-6969</b>	↺ ↻	
Rubber Buffer, suspension	E 200 CDI , E 200 Kompressor , E 220 CDI , E 230 , E 240 , E 270 CDI , E 280 , E 280 CDI , E 300 BlueTEC, E 320 , E 320 CDI , E 350 , E 350 CGI , E 400 CDI , E 420 CDI , E 500 , E 55 AMG Kompressor , E 63 AMG , E200 NGT	ch.B 187250→; <b>SP</b>	<b>F8-7713</b>		H=67
Joint, propshaft	E 200 CDI , E 200 Kompressor , E 240 , E 240 4-matic , E 320 , E 320 4-matic , E200 NGT	with fastening material	<b>F8-7720S</b>		
Joint, propshaft	E 200 CDI , E 220 CDI	with fastening material;  5-speed,  6-speed	<b>F8-7721S</b>		
Joint, propshaft	E 220 CDI , E 270 CDI , E 280 CDI	with fastening material;  5-speed	<b>F8-7721S</b>		
Joint, propshaft	E 280 CDI , E 280 CDI 4-matic, E 300 BlueTEC, E 320 CDI , E 320 CDI 4-matic	with fastening material;  6-speed	<b>F8-7721S</b>		
Joint, propshaft	E 350 , E 350 4-matic , E 350 CGI	with fastening material;  6-speed,  7-speed	<b>F8-7721S</b>		
Joint, propshaft	E 500	with fastening material;  5-speed,  6-speed,  7-speed	<b>F8-7721S</b>		
Engine Mounting	E 200 Kompressor , E200 NGT	Aluminium	<b>F8-7747</b>		L=104
Engine Mounting	E 240 , E 270 CDI , E 320	Aluminium; not for  5-speed	<b>F8-7747</b>		L=104
Engine Mounting	E 280 CDI , E 280 CDI 4-matic, E 300 BlueTEC, E 320 CDI , E 320 CDI 4-matic	Aluminium; not for  6-speed, not for  7-speed	<b>F8-7747</b>		L=104
Rubber Buffer, suspension	E 200 CDI , E 200 Kompressor , E 220 CDI , E 230 , E 240 , E 270 CDI , E 280 , E 280 CDI , E 300 BlueTEC, E 320 , E 320 CDI , E 350 , E 350 CGI , E 400 CDI , E 420 CDI , E 500 , E 55 AMG Kompressor , E 63 AMG , E200 NGT	<b>ST</b>	<b>F8-7799</b>		H=87
Control Arm-/Trailing Arm Bush	E 200 CDI , E 200 Kompressor , E 220 CDI , E 230 , E 240 4-matic , E 270 CDI , E 280 , E 280 CDI , E 280 CDI 4-matic, E 300 BlueTEC, E 320 , E 320 4-matic , E 320 CDI , E 350 , E 350 4-matic , E 350 CGI , E 400 CDI , E 420 CDI , E 500 , E 500 4-matic , E2		<b>F8-8129</b>	↺ ↻	d=12; D=38,5
Control Arm-/Trailing Arm Bush	3.5 4-matic, E 200 CDI , E 200 Kompressor , E 220 CDI , E 230 , E 240 , E 240 4-matic , E 270 CDI , E 280 , E 280 4-matic , E 280 CDI , E 280 CDI 4-matic, E 300 BlueTEC, E 320 , E 320 4-matic , E 320 CDI , E 320 CDI 4-matic, E 350 , E 350 4-matic , E 350		<b>F8-8130</b>	↺ ↻	
Engine Mounting	E 280 CDI , E 320 CDI , E 350 , E 500		<b>F8-8153</b>		
Engine Mounting	E 200 CDI	ch.→A258825, X110298	<b>F8-8175</b>	↺	
Engine Mounting	E 200 CDI , E 220 CDI , E 280		<b>F8-8175</b>	↺	
Engine Mounting	E 270 CDI	ch.→A517938	<b>F8-8175</b>	↺	

**E-CLASS T-Model (S211)** 03/2003 → 07/2009

Alternator Freewheel Clutch	E 200 Kompressor , E 200 T Kompressor		<b>F5-1056</b>		
-----------------------------	---------------------------------------	--	----------------	--	--

<b>F5-1056</b>	<b>F5-1058</b>	<b>F8-6968</b>	<b>F8-6969</b>	<b>F8-7713</b>	<b>F8-7720S</b>	<b>F8-7721S</b>
Ref.Nr.: 2711550016	Ref.Nr.: 6461500260	Ref.Nr.: 2112400017	Ref.Nr.: 2112402017	Ref.Nr.: A2113210006	Ref.Nr.: 2114100115	Ref.Nr.: 2114100415
<b>F8-7747</b>	<b>F8-7799</b>	<b>F8-8129</b>	<b>F8-8130</b>	<b>F8-8153</b>	<b>F8-8175</b>	
Ref.Nr.: 1402401218	Ref.Nr.: A2113230444	Ref.Nr.: 2303521865	Ref.Nr.: A2303521465	Ref.Nr.: 2112403017	Ref.Nr.: 2112400317	

**Article Description****Article Nr.****Fitting Position**

<b>E-CLASS T-Model (S211)</b>		<b>03/2003 → 07/2009</b>	
Alternator Freewheel Clutch	E 200 CDI , E 220 CDI , E 220 T CDI , E 270 T CDI , E 280 T CDI , E 320 T CDI		<b>F5-1058</b>
Alternator Freewheel Clutch	E 280 T CDI , E 280 T CDI 4-matic , E 320 T CDI , E 320 T CDI 4-matic		<b>F5-1065</b>
Alternator Freewheel Clutch	E 280 T CDI , E 320 T CDI , E 320 T CDI 4-matic		<b>F5-1126</b>
Belt Pulley, crankshaft	E 200 Kompressor , E 200 T Kompressor , E 220 T CDI , E 240 T , E 240 T 4-matic , E 270 T CDI , E 280 T , E 280 T 4-matic , E 280 T CDI , E 280 T CDI 4-matic , E 320 T , E 320 T 4-matic , E 320 T CDI , E 320 T CDI 4-matic , E 350 T , E 350 T 4-matic , E 5	Parameter: 6PK	<b>F8-5663</b>
Top Strut Mounting	350 CGI , E 200 CDI , E 200 Kompressor , E 200 T Kompressor , E 220 T CDI , E 230 T , E 240 T , E 270 T CDI , E 280 T , E 280 T CDI , E 320 T , E 320 T CDI , E 500 T , E 55 T AMG Kompressor , E 63 AMG		<b>F8-6059</b>
Top Strut Mounting	E 220 CDI , E 280 T CDI 4-matic	not for equipment variant: Airmatic;	<b>F8-6059</b>
Top Strut Mounting	E 350 T	M 272.964;	<b>F8-6059</b>
Control Arm-/Trailing Arm Bush	E 200 CDI , E 200 Kompressor , E 200 T Kompressor , E 220 T CDI , E 240 T , E 270 T CDI , E 280 T , E 280 T CDI , E 320 T , E 320 T CDI , E 350 T , E 500 T , E 55 T AMG Kompressor		<b>F8-6112</b>
Control Arm-/Trailing Arm Bush	350 CGI , E 200 CDI , E 200 Kompressor , E 200 T Kompressor , E 220 T CDI , E 230 T , E 240 T , E 270 T CDI , E 280 T , E 280 T CDI , E 320 T , E 320 T CDI , E 350 T , E 500 T , E 55 T AMG Kompressor , E 63 AMG		<b>F8-6113</b>
Mounting, axle beam	E 200 T Kompressor , E 220 T CDI , E 240 T , E 240 T 4-matic , E 270 T CDI , E 320 T , E 320 T 4-matic , E 320 T CDI , E 500 T , E 55 T AMG Kompressor		<b>F8-6119</b>
Mounting, axle beam	E 200 T Kompressor , E 220 T CDI , E 240 T , E 240 T 4-matic , E 270 T CDI , E 320 T , E 320 T 4-matic , E 320 T CDI , E 500 T		<b>F8-6120</b>
Mounting, axle beam	E 200 T Kompressor , E 220 T CDI , E 240 T , E 240 T 4-matic , E 270 T CDI , E 280 T CDI , E 320 T , E 320 T 4-matic , E 320 T CDI , E 500 T , E 500 T 4-matic		<b>F8-6144</b>
Control Arm-/Trailing Arm Bush	350 CGI , E 200 CDI , E 200 Kompressor , E 200 T Kompressor , E 220 T CDI , E 230 T , E 240 T , E 240 T 4-matic , E 270 T CDI , E 280 T , E 280 T CDI , E 280 T CDI 4-matic , E 320 T , E 320 T 4-matic , E 320 T CDI , E 350 T , E 350 T 4-matic , E 500 T , E		<b>F8-6145</b>
Tie Bar Bush	E 55 T AMG Kompressor		<b>F8-6161</b>
Mounting, axle beam	350 CGI , E 200 CDI , E 200 Kompressor , E 200 T Kompressor , E 220 T CDI , E 230 T , E 240 T , E 240 T 4-matic , E 270 T CDI , E 280 T , E 280 T CDI , E 320 T , E 320 T 4-matic , E 320 T CDI , E 350 T , E 350 T 4-matic , E 500 T , E 500 T 4-matic , E 55		<b>F8-6181</b>

<b>F5-1058</b>	<b>F5-1065</b>	<b>F5-1126</b>	<b>F8-5663</b>	<b>F8-6059</b>	<b>F8-6112</b>	<b>F8-6113</b>
Ref.Nr.: 6461500260	Ref.Nr.: 6281500060	Ref.Nr.: 05175811AA	Ref.Nr.: 1120350800	Ref.Nr.: 2113200026	Ref.Nr.: 2113332914	Ref.Nr.: 2113331914
<b>F8-6119</b>	<b>F8-6120</b>	<b>F8-6144</b>	<b>F8-6145</b>	<b>F8-6161</b>	<b>F8-6181</b>	<b>F8-6182</b>
Ref.Nr.: 2113510642	Ref.Nr.: 2113510842	Ref.Nr.: 2303511442	Ref.Nr.: 2303521565	Ref.Nr.: 2113520865	Ref.Nr.: 2303510242	Ref.Nr.: 2203521365

Article Description



Article Nr.

Fitting Position



<b>E-CLASS T-Model (S211)</b>		<b>03/2003 → 07/2009</b>		
Mounting, axle beam	E 200 CDI , E 200 Kompressor , E 200 T Kompressor , E 220 T CDI , E 240 T , E 240 T 4-matic , E 270 T CDI , E 280 T , E 280 T CDI , E 280 T CDI 4-matic , E 320 T , E 320 T 4-matic , E 320 T CDI , E 350 T , E 350 T 4-matic , E 500 T , E 500 T 4-matic , E 5		F8-6182	H=78; d=12; D=51.5
Mounting, axle beam	350 CGI , E 200 CDI , E 200 Kompressor , E 200 T Kompressor , E 220 T CDI , E 230 T , E 240 T , E 240 T 4-matic , E 270 T CDI , E 280 T , E 280 T CDI , E 280 T CDI 4-matic , E 320 T , E 320 T 4-matic , E 320 T CDI , E 350 T , E 350 T 4-matic , E 500 T , E		F8-6184	
Control Arm-/Trailing Arm Bush	E 200 Kompressor , E 200 T Kompressor , E 220 T CDI , E 240 T , E 270 T CDI , E 280 T , E 280 T CDI , E 320 T , E 320 T CDI , E 350 T , E 500 T , E 55 T AMG Kompressor , E 63 AMG		F8-6651	
Joint, propshaft	E 350 T , E 350 T 4-matic	with fastening material; not for  7-speed	F8-6760	d=57.5; D=145; Thick./Strength 1 [mm]=31.5
Engine Mounting	E 200 T Kompressor		F8-6950	
Engine Mounting	E 200 T Kompressor		F8-6951	
Engine Mounting	E 240 T 4-matic , E 320 T 4-matic , E 350 T 4-matic		F8-6968	
Engine Mounting	E 500 T 4-matic		F8-6969	
Rubber Buffer, suspension	350 CGI , E 200 CDI , E 200 Kompressor , E 200 T Kompressor , E 220 CDI , E 220 T CDI , E 230 T , E 240 T , E 270 T CDI , E 280 T , E 280 T CDI , E 320 T , E 320 T CDI , E 350 T , E 500 T , E 55 T AMG Kompressor , E 63 AMG	ch.B 187250→;	F8-7713	H=67
Joint, propshaft	E 200 Kompressor , E 200 T Kompressor , E 240 T , E 240 T 4-matic , E 320 T , E 320 T 4-matic	with fastening material	F8-7720S	
Joint, propshaft	350 CGI , E 350 T	with fastening material;  6-speed,  7-speed	F8-7721S	
Joint, propshaft	E 200 CDI , E 220 T CDI	with fastening material;  5-speed,  6-speed	F8-7721S	
Joint, propshaft	E 220 CDI , E 220 T CDI , E 270 T CDI , E 280 T CDI , E 350 T 4-matic	with fastening material;  5-speed	F8-7721S	
Joint, propshaft	E 280 T CDI , E 280 T CDI 4-matic , E 320 T CDI , E 320 T CDI 4-matic	with fastening material;  6-speed	F8-7721S	
Joint, propshaft	E 500 T	with fastening material;  5-speed,  6-speed,  7-speed	F8-7721S	
Engine Mounting	E 200 Kompressor , E 200 T Kompressor	Aluminium	F8-7747	L=104
Engine Mounting	E 240 T , E 270 T CDI , E 320 T	Aluminium; not for  5-speed	F8-7747	L=104
Engine Mounting	E 280 T CDI , E 280 T CDI 4-matic , E 320 T CDI , E 320 T CDI 4-matic	Aluminium; not for  6-speed, not for  7-speed	F8-7747	L=104

<b>F8-6182</b>	<b>F8-6184</b>	<b>F8-6651</b>	<b>F8-6760</b>	<b>F8-6950</b>	<b>F8-6951</b>	<b>F8-6968</b>
Ref.Nr.: 2203521365	Ref.Nr.: 2113511442	Ref.Nr.: 2113332214	Ref.Nr.: 0004110200	Ref.Nr.: 2032401917	Ref.Nr.: 2032402017	Ref.Nr.: 2112400017
<b>F8-6969</b>	<b>F8-7713</b>	<b>F8-7720S</b>	<b>F8-7721S</b>	<b>F8-7747</b>	<b>F8-7799</b>	
Ref.Nr.: 2112402017	Ref.Nr.: A2113210006	Ref.Nr.: 2114100115	Ref.Nr.: 2114100415	Ref.Nr.: 1402401218	Ref.Nr.: A2113230444	

**Article Description****Article Nr.****Fitting Position****E-CLASS T-Model (S211) 03/2003 → 07/2009**

Rubber Buffer, suspension	350 CGI , E 200 CDI , E 200 Kompressor , E 200 T Kompressor , E 220 CDI , E 220 T CDI , E 230 T , E 240 T , E 270 T CDI , E 280 T , E 280 T CDI , E 320 T , E 320 T CDI , E 350 T , E 500 T , E 55 T AMG Kompressor , E 63 AMG		<b>F8-7799</b>		H=87
Control Arm-/Trailing Arm Bush	350 CGI , E 200 CDI , E 200 Kompressor , E 200 T Kompressor , E 220 CDI , E 220 T CDI , E 230 T , E 240 T , E 240 T 4-matic , E 270 T CDI , E 280 T , E 280 T CDI , E 280 T CDI 4-matic , E 320 T , E 320 T 4-matic , E 320 T CDI , E 350 T , E 350 T 4-matic ,		<b>F8-8129</b>	⊕ ⊕	d=12; D=38,5
Control Arm-/Trailing Arm Bush	All Models		<b>F8-8130</b>	⊕ ⊕	
Engine Mounting	350 CGI , E 230 T , E 280 T CDI , E 320 T CDI , E 350 T , E 500 T		<b>F8-8153</b>		
Engine Mounting	E 200 CDI , E 220 CDI , E 220 T CDI , E 280 T		<b>F8-8175</b>	⊕ ⊕	
Engine Mounting	E 200 CDI , E 220 CDI , E 220 T CDI , E 280 T		<b>F8-8175</b>	⊕	
Engine Mounting	E 270 T CDI	ch.→A517938	<b>F8-8175</b>	⊕	

**E-CLASS (W212) 01/2009 → 08/2011**

Alternator Freewheel Clutch	E 300 CDI , E 350 BlueTEC , E 350 BlueTEC 4-matic , E 350 CDI , E 350 CDI 4-matic		<b>F5-1065</b>		
Alternator Freewheel Clutch	E 300 CDI , E 350 BlueTEC , E 350 BlueTEC 4-matic , E 350 CDI , E 350 CDI 4-matic		<b>F5-1126</b>		
Control Arm-/Trailing Arm Bush	E 200 CDI , E 200 CGI , E 220 CDI , E 250 CDI , E 250 CGI , E 350 4-matic , E 350 BlueTEC , E 350 CDI , E 350 CGI , E 500 , E 500 4-matic		<b>F8-6145</b>	⊕ ⊕	d=12.2
Mounting, axle beam	E 200 CGI , E 220 CDI , E 250 CDI , E 250 CGI , E 350 4-matic , E 350 BlueTEC , E 350 CDI , E 350 CGI , E 500 , E 500 4-matic		<b>F8-6648</b>	⊕ ⊕	
Top Strut Mounting	E 200 CDI , E 200 CGI , E 200 NGT , E 220 CDI , E 250 CDI , E 250 CDI 4-matic , E 250 CGI , E 300 , E 300 4-matic , E 300 CDI , E 300 Hybrid , E 350 , E 350 4-matic , E 350 BlueTEC , E 350 CDI , E 350 CDI 4-matic , E 350 CGI , E 500 , E 500 4-matic , E 63		<b>F8-7626</b>	⊕ ⊕	
Top Strut Mounting	E 200 CDI , E 200 CGI , E 200 NGT , E 220 CDI , E 250 CDI , E 250 CDI 4-matic , E 250 CGI , E 300 , E 300 4-matic , E 300 CDI , E 350 , E 350 4-matic , E 350 BlueTEC , E 350 CDI , E 350 CDI 4-matic , E 350 CGI , E 500 , E 500 4-matic , E 63 AMG		<b>F8-7628</b>	⊕ ⊕	
Anti-Friction Bearing	E 200 CDI , E 200 CGI , E 220 CDI , E 250 CDI , E 250 CGI , E 350 4-matic , E 350 BlueTEC , E 350 CDI , E 350 CDI 4-matic , E 350 CGI , E 500 , E 500 4-matic , E 63 AMG		<b>F8-7631</b>	⊕ ⊕	
Anti-Friction Bearing	E 350 CDI 4-matic	OM 642.856;	<b>F8-7631</b>	⊕ ⊕	

<b>F5-1065</b>	<b>F5-1126</b>	<b>F8-6145</b>	<b>F8-6648</b>	<b>F8-7626</b>	<b>F8-7628</b>	<b>F8-7631</b>
Ref.Nr.: 6281500060	Ref.Nr.: 05175811AA	Ref.Nr.: 2303521565	Ref.Nr.: 2043521065	Ref.Nr.: A2043260664	Ref.Nr.: 2123230020	Ref.Nr.: 2049810025
<b>F8-7689</b>	<b>F8-7799</b>	<b>F8-8129</b>	<b>F8-8130</b>	<b>F8-8153</b>	<b>F8-8175</b>	
Ref.Nr.: 2123210306	Ref.Nr.: A2113230444	Ref.Nr.: 2303521865	Ref.Nr.: A2303521465	Ref.Nr.: 2112403017	Ref.Nr.: 2112400317	

Article Description



Article Nr.

Fitting Position



<b>E-CLASS (W212)</b>		<b>01/2009 → 08/2011</b>		
Rubber Buffer, suspension	E 200 CDI , E 200 CGI , E 200 NGT , E 220 CDI , E 250 CDI , E 250 CGI , E 300 , E 300 CDI , E 350 , E 350 BlueTEC , E 350 CDI , E 350 CGI , E 500 , E 63 AMG	Avangarde; not for equipment variant: Sport	<b>F8-7689</b>	H=300
Rubber Buffer, suspension	E 200 CDI , E 200 CGI , E 200 NGT , E 220 CDI , E 250 CDI , E 250 CGI , E 300 , E 300 CDI , E 350 , E 350 BlueTEC , E 350 CDI , E 350 CGI , E 500 , E 63 AMG	not for equipment variant: Sport	<b>F8-7690</b>	
Rubber Buffer, suspension	E 250 CDI 4-matic , E 300 4-matic , E 350 4-matic , E 350 CDI 4-matic , E 500 4-matic	Avangarde	<b>F8-7691</b>	
Rubber Buffer, suspension	E 250 CDI 4-matic , E 300 4-matic , E 350 4-matic , E 350 CDI 4-matic , E 500 4-matic	not for equipment variant: Sport	<b>F8-7692</b>	H=300
Control Arm-/Trailing Arm Bush	E 200 CDI , E 200 CGI , E 200 NGT , E 220 CDI , E 250 CDI , E 250 CGI , E 300 , E 300 CDI , E 300 Hybrid , E 350 , E 350 BlueTEC , E 350 CDI , E 350 CGI , E 500	Aluminium	<b>F8-7739</b>	d=14.6; L=80; D=75.3
Control Arm-/Trailing Arm Bush	E 200 CDI , E 200 CGI , E 200 NGT , E 220 CDI , E 250 CDI , E 250 CGI , E 300 , E 300 CDI , E 300 Hybrid , E 350 , E 350 BlueTEC , E 350 CDI , E 350 CGI , E 500	Aluminium	<b>F8-7740</b>	d=14.2; L=80; D=53.2
Protective Cap/Bellow, shock absorber	E 200 , E 200 CDI , E 200 CGI , E 200 NGT , E 220 CDI , E 250 , E 250 CDI , E 250 CDI 4-matic , E 250 CGI , E 300 , E 300 4-matic , E 300 CDI , E 300 Hybrid , E 350 , E 350 4-matic , E 350 BlueTEC , E 350 BlueTEC 4-matic , E 350 CDI , E 350 CDI 4-matic , E 35	for vehicles without electronic drive dynamics regulation	<b>F8-7899</b>	H=224
Control Arm-/Trailing Arm Bush	E 220 BlueTEC 4-matic , E 250 CDI 4-matic , E 300 4-matic , E 350 4-matic , E 350 BlueTEC 4-matic , E 350 CDI 4-matic , E 400 4-matic , E 500 4-matic		<b>F8-8116</b>	H=80; d=14,2; D=75,5
Bellow, driveshaft	E 220 BlueTEC 4-matic , E 250 CDI 4-matic , E 350 BlueTEC 4-matic , E 350 CDI 4-matic		<b>M-871000</b>	
Bellow Set, drive shaft	E 220 BlueTEC 4-matic , E 250 CDI 4-matic , E 350 BlueTEC 4-matic , E 350 CDI 4-matic		<b>MK-871000</b>	
<b>E-CLASS Convertible (A207)</b>		<b>01/2010 →</b>		
Alternator Freewheel Clutch	E 350 BlueTEC		<b>F5-1065</b>	
Alternator Freewheel Clutch	E 350 BlueTEC, E 350 CDI		<b>F5-1126</b>	
Top Strut Mounting	E 200 , E 200 CGI , E 220 CDI , E 250 , E 250 CDI , E 250 CGI , E 300 , E 350 , E 350 BlueTEC , E 350 CDI , E 350 CGI , E 400 , E 500 , E 550 CGI		<b>F8-7477</b>	
Top Strut Mounting	E 200 , E 200 CGI , E 220 CDI , E 250 , E 250 CDI , E 250 CGI , E 300 , E 350 , E 350 BlueTEC , E 350 CDI , E 350 CGI , E 400 , E 500 , E 550 CGI		<b>F8-7478</b>	
Top Strut Mounting	E 200 CGI , E 220 CDI , E 250 CDI , E 250 CGI , E 300 , E 350 , E 350 CDI , E 350 CGI , E 500		<b>F8-7626</b>	
Anti-Friction Bearing	E 200 CGI , E 220 CDI , E 250 CDI , E 250 CGI , E 350 CDI , E 350 CGI , E 500		<b>F8-7631</b>	

<b>F5-1065</b>	<b>F5-1126</b>	<b>F8-7477</b>	<b>F8-7478</b>	<b>F8-7626</b>	<b>F8-7631</b>	<b>F8-7671</b>
Ref.Nr.: 6281500060	Ref.Nr.: 05175811AA	Ref.Nr.: 2043201273	Ref.Nr.: 2043200073	Ref.Nr.: A2043260664	Ref.Nr.: 2049810025	Ref.Nr.: 2043306811
<b>F8-7689</b>	<b>F8-7690</b>	<b>F8-7691</b>	<b>F8-7692</b>	<b>F8-7739</b>	<b>F8-7740</b>	<b>F8-7899</b>
Ref.Nr.: 2123210306	Ref.Nr.: 2123210106	Ref.Nr.: 2123210706	Ref.Nr.: 2123210906	Ref.Nr.: 2123330014	Ref.Nr.: 2123330514	Ref.Nr.: 2123230392
<b>F8-8116</b>	<b>M-871000</b>	<b>MK-871000</b>				
Ref.Nr.: A2123330314	Ref.Nr.: 2213300285	Ref.Nr.: A2213300285				

**Article Description****Article Nr.****Fitting Position**

<b>E-CLASS Convertible (A207)</b>			<b>01/2010 →</b>		
Control Arm-/Trailing Arm Bush	E 200 CGI , E 220 CDI , E 250 CDI , E 250 CGI , E 350 CDI , E 350 CGI , E 500	Aluminium	<b>F8-7671</b>		
Control Arm-/Trailing Arm Bush	E 200 CGI , E 220 CDI , E 250 CDI , E 250 CGI , E 300 , E 350 , E 350 CDI , E 350 CGI , E 500	Shape Round; without cap	<b>F8-7858</b>		H1=80; H2=61; d=15; D=70.2
Protective Cap/Bellow, shock absorber	E 200 , E 200 CGI , E 220 CDI , E 250 , E 250 CDI , E 250 CGI , E 300 , E 350 , E 350 BlueTEC , E 350 BlueTEC Hybrid , E 350 CDI , E 350 CGI , E 400 , E 500 , E 550 CGI	for vehicles without electronic drive dynamics regulation	<b>F8-7899</b>		H=224
<b>E-CLASS Coupe (C207)</b>			<b>01/2009 →</b>		
Alternator Freewheel Clutch	E 350 BlueTEC		<b>F5-1065</b>		
Alternator Freewheel Clutch	E 350 BlueTEC , E 350 CDI		<b>F5-1126</b>		
Control Arm-/Trailing Arm Bush	E 250 CDI , E 250 CGI , E 350 CDI , E 350 CGI , E 500		<b>F8-6145</b>		d=12.2
Mounting, axle beam	E 250 CDI , E 250 CGI , E 350 CDI , E 350 CGI , E 500		<b>F8-6648</b>		
Top Strut Mounting	E 200 , E 200 CGI , E 220 CDI , E 250 , E 250 CDI , E 250 CGI , E 300 , E 350 , E 350 BlueTEC , E 350 CDI , E 350 CGI , E 400 , E 500 , E 550 CGI		<b>F8-7477</b>		
Top Strut Mounting	E 200 , E 200 CGI , E 220 CDI , E 250 , E 250 CDI , E 250 CGI , E 300 , E 350 , E 350 BlueTEC , E 350 CDI , E 350 CGI , E 400 , E 500 , E 550 CGI		<b>F8-7478</b>		
Top Strut Mounting	E 200 CGI , E 220 CDI , E 250 CDI , E 250 CGI , E 300 , E 350 , E 350 CDI , E 350 CGI , E 500		<b>F8-7626</b>		
Anti-Friction Bearing	E 200 CGI , E 220 CDI , E 250 CDI , E 250 CGI , E 350 CDI , E 350 CGI , E 500		<b>F8-7631</b>		
Control Arm-/Trailing Arm Bush	E 250 CDI , E 250 CGI , E 350 CDI , E 350 CGI , E 500	Aluminium	<b>F8-7671</b>		
Control Arm-/Trailing Arm Bush	E 200 CGI , E 220 CDI , E 250 CDI , E 250 CGI , E 300 , E 350 , E 350 CDI , E 350 CGI , E 500	Shape Round; without cap	<b>F8-7858</b>		H1=80; H2=61; d=15; D=70.2
Protective Cap/Bellow, shock absorber	E 200 , E 200 CGI , E 220 CDI , E 250 , E 250 CDI , E 250 CGI , E 300 , E 350 , E 350 4-matic , E 350 BlueTEC , E 350 CDI , E 350 CGI , E 400 , E 500 , E 550 CGI	for vehicles without electronic drive dynamics regulation	<b>F8-7899</b>		H=224
Bellow, driveshaft	E 350 4-matic		<b>M-871000</b>		
Bellow Set, drive shaft	E 350 4-matic		<b>MK-871000</b>		
<b>E-CLASS T-Model (S212)</b>			<b>08/2009 → 12/2010</b>		
Alternator Freewheel Clutch	E 300 CDI	Alternator Charge Current [A]: 220; for OE: 0141541302; Manufacturer Restriction: Bosch	<b>F5-1065</b>		
Alternator Freewheel Clutch	E 350 BlueTEC , E 350 BlueTEC 4-matic , E 350 CDI , E 350 CDI 4-matic		<b>F5-1065</b>		
Alternator Freewheel Clutch	E 300 CDI , E 350 BlueTEC , E 350 BlueTEC 4-matic , E 350 CDI , E 350 CDI 4-matic		<b>F5-1126</b>		

<b>F5-1065</b>	<b>F5-1126</b>	<b>F8-6145</b>	<b>F8-6648</b>	<b>F8-7477</b>	<b>F8-7478</b>	<b>F8-7626</b>
Ref.Nr.: 6281500060	Ref.Nr.: 05175811AA	Ref.Nr.: 2303521565	Ref.Nr.: 2043521065	Ref.Nr.: 2043201273	Ref.Nr.: 2043200073	Ref.Nr.: A2043260664
<b>F8-7631</b>	<b>F8-7671</b>	<b>F8-7858</b>	<b>F8-7899</b>	<b>M-871000</b>	<b>MK-871000</b>	
Ref.Nr.: 2049810025	Ref.Nr.: 2043306811	Ref.Nr.: 2033331014	Ref.Nr.: 2123230392	Ref.Nr.: 2213300285	Ref.Nr.: A2213300285	

Article Description

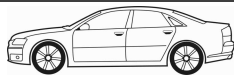

Article Nr.

Fitting Position



<b>E-CLASS T-Model (S212)</b>		<b>08/2009 → 12/2010</b>	
Control Arm-/Trailing Arm Bush	E 200 CGI, E 220 CDI, E 250 CDI, E 250 CGI, E 350 4-matic, E 350 CDI, E 350 CDI 4-matic, E 350 CGI, E 500, E 63 AMG		F8-6145
Mounting, axle beam	E 200 CGI, E 220 CDI, E 250 CDI, E 250 CGI, E 350 4-matic, E 350 CDI, E 350 CDI 4-matic, E 350 CGI, E 500, E 63 AMG		F8-6648
Top Strut Mounting	E 200 CDI, E 200 CGI, E 220 CDI, E 250 CDI, E 250 CDI 4-matic, E 250 CGI, E 300, E 300 4-matic, E 300 CDI, E 350, E 350 4-matic, E 350 BlueTEC, E 350 CDI, E 350 CDI 4-matic, E 350 CGI, E 500, E 500 4-matic, E 63 AMG		F8-7626
Top Strut Mounting	E 200 CDI, E 200 CGI, E 220 CDI, E 250 CDI, E 250 CDI 4-matic, E 250 CGI, E 300, E 300 4-matic, E 350, E 350 4-matic, E 350 BlueTEC, E 350 CDI, E 350 CDI 4-matic, E 350 CGI, E 500, E 500 4-matic, E 63 AMG	; <b>ST</b>	F8-7628
Anti-Friction Bearing	E 200 CDI, E 200 CGI, E 220 CDI, E 250 CDI, E 250 CGI, E 350 4-matic, E 350 BlueTEC, E 350 CDI, E 350 CDI 4-matic, E 350 CGI, E 500, E 63 AMG		F8-7631
Rubber Buffer, suspension	E 200 CDI, E 200 CGI, E 220 CDI, E 250 CDI, E 250 CGI, E 300, E 350, E 350 BlueTEC, E 350 CDI, E 350 CGI, E 500, E 63 AMG	Avangarde; not for equipment variant: Sport	F8-7689  H=300
Rubber Buffer, suspension	E 200 CDI, E 200 CGI, E 220 CDI, E 250 CDI, E 250 CGI, E 300, E 350, E 350 BlueTEC, E 350 CDI, E 350 CGI, E 500, E 63 AMG	not for equipment variant: Sport	F8-7690
Rubber Buffer, suspension	E 250 CDI 4-matic, E 300 4-matic, E 350 4-matic, E 350 CDI 4-matic, E 500 4-matic	Avangarde	F8-7691
Rubber Buffer, suspension	E 250 CDI 4-matic, E 300 4-matic, E 350 4-matic, E 350 CDI 4-matic, E 500 4-matic	not for equipment variant: Sport	F8-7692  H=300
Control Arm-/Trailing Arm Bush	E 200 CDI, E 200 CGI, E 220 CDI, E 250 CDI, E 250 CGI, E 300, E 300 CDI, E 350, E 350 BlueTEC, E 350 CDI, E 350 CGI, E 500	Aluminium	F8-7739     d=14.6; L=80; D=75.3
Control Arm-/Trailing Arm Bush	E 200 CDI, E 200 CGI, E 220 CDI, E 250 CDI, E 250 CGI, E 300, E 300 CDI, E 350, E 350 BlueTEC, E 350 CDI, E 350 CGI, E 500	Aluminium	F8-7740     d=14.2; L=80; D=53.2
Protective Cap/Bellow, shock absorber	E 200, E 200 CDI, E 200 CGI, E 220 CDI, E 250, E 250 CDI, E 250 CDI 4-matic, E 250 CGI, E 300, E 300 4-matic, E 300 CDI, E 300 Hybrid, E 350, E 350 4-matic, E 350 BlueTEC, E 350 BlueTEC 4-matic, E 350 BlueTEC Hybrid, E 350 CDI, E 350 CDI 4-matic	for vehicles without electronic drive dynamics regulation	F8-7899    H=224
Control Arm-/Trailing Arm Bush	E 220 BlueTEC 4-matic, E 250 CDI 4-matic, E 300 4-matic, E 350 4-matic, E 350 BlueTEC 4-matic, E 350 CDI 4-matic, E 400 4-matic, E 500 4-matic		F8-8116    H=80; d=14,2; D=75,5
<b>G-CLASS (W460)</b>		<b>03/1979 → 07/1993</b>	
Stabiliser Mounting	230 G, 240 GD, 250 GD, 280 GE, 300 GD		F8-8101  d=12; D=30
Stabiliser Mounting	230 GE	M 102.981	F8-8101  d=12; D=30

<b>F8-6145</b>	<b>F8-6648</b>	<b>F8-7626</b>	<b>F8-7628</b>	<b>F8-7631</b>	<b>F8-7689</b>	<b>F8-7690</b>
Ref.Nr.: 2303521565	Ref.Nr.: 2043521065	Ref.Nr.: A2043260664	Ref.Nr.: 2123230020	Ref.Nr.: 2049810025	Ref.Nr.: 2123210306	Ref.Nr.: 2123210106
<b>F8-7691</b>	<b>F8-7692</b>	<b>F8-7739</b>	<b>F8-7740</b>	<b>F8-7899</b>	<b>F8-8101</b>	<b>F8-8116</b>
Ref.Nr.: 2123210706	Ref.Nr.: 2123210906	Ref.Nr.: 2123330014	Ref.Nr.: 2123330514	Ref.Nr.: 2123230392	Ref.Nr.: 3093200073	Ref.Nr.: A2123330314





Article Description



Article Nr.

Fitting Position



<b>G-CLASS (W460)</b>			<b>03/1979 → 07/1993</b>		
Stabiliser Mounting	230 GE	M 102.987	<b>F8-8101</b>		d=12; D=30
Stabiliser Mounting	240 GD	OM 616.936	<b>F8-8101</b>		d=12; D=30
<b>G-CLASS (W461)</b>			<b>02/1990 →</b>		
Alternator Freewheel Clutch	G 290 TD		<b>F5-1003</b>		
Stabiliser Mounting	230 GE , 290 GD/G 290 D , G 290 TD		<b>F8-5222</b>	⊕ ⊕	d=30
Stabiliser Mounting	230 GE , 250 GD , 290 GD/G 290 D , G 290 TD		<b>F8-8101</b>		d=12; D=30
<b>G-CLASS (W463)</b>			<b>09/1989 → 12/1997</b>		
Alternator Freewheel Clutch	G 300 TD		<b>F5-1003</b>		
Alternator Freewheel Clutch	G 270 CDI		<b>F5-1018</b>		
Alternator Freewheel Clutch	G 400 CDI		<b>F5-1042</b>		
Alternator Freewheel Clutch	G 350 CDI, G 400 CDI		<b>F5-1065</b>		
Alternator Freewheel Clutch	G 320 CDI	ch.→175012	<b>F5-1111</b>		
Alternator Freewheel Clutch	G 350 CDI		<b>F5-1111</b>		
Alternator Freewheel Clutch	G 350 CDI		<b>F5-1114</b>		
Alternator Freewheel Clutch	G 320 CDI , G 350 CDI		<b>F5-1126</b>		
Stabiliser Mounting	300 GE , 350 G Turbo D , G 300 TD , G 320 , G 500 , G 55 AMG		<b>F8-5222</b>	⊕ ⊕	d=30
Belt Pulley, crankshaft	G 320 , G 500	Parameter: 6PK	<b>F8-5663</b>		d=32; D1=160; D2=157; W1=82
Engine Mounting	G 320 , G 320 CDI , G 350 CDI	Aluminium	<b>F8-7747</b>		L=104
Stabiliser Mounting	200 GE , 230 GE , 250 GD , 300 GD , 300 GE , 350 G Turbo D , G 270 CDI , G 300 TD , G 320 , G 320 CDI , G 400 CDI , G 500 , G 500 E , G 55 AMG		<b>F8-8101</b>		d=12; D=30
<b>G-CLASS Cabrio (W463)</b>			<b>09/1989 → 11/1997</b>		
Alternator Freewheel Clutch	G 300 TD		<b>F5-1003</b>		
Alternator Freewheel Clutch	G 400 CDI		<b>F5-1042</b>		
Alternator Freewheel Clutch	G 350 CDI, G 400 CDI		<b>F5-1065</b>		
Alternator Freewheel Clutch	G 320 CDI	ch.→175012	<b>F5-1111</b>		
Alternator Freewheel Clutch	G 350 CDI		<b>F5-1111</b>		
Alternator Freewheel Clutch	G 350 CDI		<b>F5-1114</b>		
Alternator Freewheel Clutch	G 320 CDI, G 350 CDI		<b>F5-1126</b>		
Stabiliser Mounting	320 GE , G 320		<b>F8-5222</b>	⊕ ⊕	d=30
Belt Pulley, crankshaft	G 320 , G 500	Parameter: 6PK	<b>F8-5663</b>		d=32; D1=160; D2=157; W1=82
Engine Mounting	G 320 , G 320 CDI	Aluminium	<b>F8-7747</b>		L=104
Stabiliser Mounting	200 GE , 230 GE , 300 GD , 300 GE , 320 GE , 350 G Turbo-D , G 300 TD , G 320 , G 320 CDI, G 400 CDI , G 500		<b>F8-8101</b>		d=12; D=30



<b>Article Description</b>			<b>Article Nr.</b>	<b>Fitting Position</b>	
----------------------------	--	--	--------------------	-------------------------	--

<b>GL-CLASS (X164)</b>				<b>09/2006 → 05/2009</b>	
Alternator Freewheel Clutch	GL 320 CDI , GL 350 CDI , GL 350 CDI BlueTEC		<b>F5-1065</b>		
Alternator Freewheel Clutch	GL 320 CDI , GL 350 CDI		<b>F5-1111</b>		
Alternator Freewheel Clutch	GL 320 CDI , GL 350 CDI		<b>F5-1114</b>		
Alternator Freewheel Clutch	GL 320 CDI , GL 350 CDI , GL 350 CDI BlueTEC		<b>F5-1126</b>		
<b>GLK-CLASS (X204)</b>				<b>06/2008 → 04/2011</b>	
Alternator Freewheel Clutch	320 CDI 4-matic , 350 CDI 4-matic		<b>F5-1126</b>		
Control Arm-/Trailing Arm Bush	280 4-matic , 320 CDI 4-matic , 350 4-matic		<b>F8-6145</b>		d=12.2
Mounting, axle beam	280 4-matic , 320 CDI 4-matic , 350 4-matic		<b>F8-6648</b>		
Top Strut Mounting	200 CDI , 220 CDI , 220 CDI 4-matic , 250 CDI 4-matic , 280 4-matic , 300 4-matic , 320 CDI 4-matic , 350 , 350 4-matic , 350 CDI 4-matic		<b>F8-7626</b>		
Anti-Friction Bearing	220 CDI , 220 CDI 4-matic , 250 CDI 4-matic , 280 4-matic , 300 4-matic , 320 CDI 4-matic , 350 4-matic , 350 CDI 4-matic		<b>F8-7631</b>		
Control Arm-/Trailing Arm Bush	220 CDI , 220 CDI 4-matic , 250 CDI 4-matic , 280 4-matic , 300 4-matic , 320 CDI 4-matic , 350 4-matic , 350 CDI 4-matic	Shape Round; without cap	<b>F8-7858</b>		H1=80; H2=61; d=15; D=70.2
Protective Cap/Bellow, shock absorber	200, 200 CDI , 220 CDI , 220 CDI 4-matic , 250, 250 4-matic , 250 CDI 4-matic , 280 4-matic , 300 4-matic , 320 CDI 4-matic , 350, 350 4-matic , 350 CDI 4-matic	for vehicles without electronic drive dynamics regulation	<b>F8-7899</b>		H=224
<b>KOMBI Estate (S123)</b>				<b>09/1977 → 12/1985</b>	
Repair Kit, reversing lever	200 T , 230 T , 230 TE , 240 T D , 250 T , 280 TE , 300 T D , 300 T Turbo-D		<b>F7-9001</b>		
Mounting, propshaft	200 T , 230 T , 230 TE , 240 T D , 250 T , 280 TE , 300 T D , 300 T Turbo-D		<b>F8-4001</b>		H=108; d=55; D=95; $\tau$ [mm]=128
Control Arm-/Trailing Arm Bush	200 T , 230 T , 230 TE , 240 T D , 250 T , 280 TE , 300 T D , 300 T Turbo-D		<b>F8-4005</b>		H=64.5; d=16.4; D1=42; D2=53
Suspension Kit	300 T D , 300 T Turbo-D		<b>F8-5009</b>		
Suspension Kit	200 T , 230 T , 230 TE , 240 T D , 250 T , 280 TE , 300 T D , 300 T Turbo-D		<b>F8-5020</b>		
Suspension Kit	200 T , 230 T , 230 TE , 240 T D , 250 T , 280 TE , 300 T D , 300 T Turbo-D		<b>F8-5178</b>		
Stabiliser Mounting	230 T , 250 T , 280 TE		<b>F8-5670</b>		d=13
Repair Set, axle beam	200 T , 230 T , 230 TE , 240 T D , 250 T , 280 TE , 300 T D , 300 T Turbo-D		<b>F8-5730</b>		d=16; L=65; D=54
Mounting, axle beam	230 T		<b>F8-5732</b>		H=65; d=16; D=85
Repair Set, axle beam	230 T	ch.004325→	<b>F8-5739</b>		
Rubber Buffer, suspension	All Models		<b>F8-5770</b>		H=63
Joint, propshaft	250 T , 280 TE , 300 T Turbo-D		<b>F8-6235</b>		Bolt Hole Circle Ø [mm]=90
Mounting, manual transmission	250 T , 280 TE		<b>F8-6498</b>		

<b>F5-1065</b>	<b>F5-1111</b>	<b>F5-1114</b>	<b>F5-1126</b>	<b>F7-9001</b>	<b>F8-4001</b>	<b>F8-4005</b>
Ref.Nr.: 6281500060	Ref.Nr.: 6421500760	Ref.Nr.: 6291500060	Ref.Nr.: 05175811AA	Ref.Nr.: 1234600050	Ref.Nr.: 1164102781	Ref.Nr.: 1153523265
<b>F8-5009</b>	<b>F8-5020</b>	<b>F8-5178</b>	<b>F8-5670</b>	<b>F8-5730</b>	<b>F8-5732</b>	<b>F8-5739</b>
Ref.Nr.: 1243300275	Ref.Nr.: 1165860133	Ref.Nr.: 1233301375	Ref.Nr.: 2013261081	Ref.Nr.: 1153523665	Ref.Nr.: 1233511042	Ref.Nr.: 1233500175
<b>F8-5770</b>	<b>F8-6145</b>	<b>F8-6235</b>	<b>F8-6498</b>	<b>F8-6648</b>	<b>F8-7626</b>	<b>F8-7631</b>
Ref.Nr.: 1153200344	Ref.Nr.: 2303521565	Ref.Nr.: 1264100215	Ref.Nr.: 1242400018	Ref.Nr.: 2043521065	Ref.Nr.: A2043260664	Ref.Nr.: 2049810025



Article Description



Article Nr.

Fitting Position



<b>KOMBI Estate (S123)</b>			<b>09/1977 → 12/1985</b>		
Engine Mounting	200 T, 230 TE	✱	<b>F8-8194</b>	⊕	
Control Arm-/Trailing Arm Bush	All Models		<b>G9-514</b>	⊕ ⊕ ⊕ ⊕	H=33; d=12; D1=43; D2=51
Control Arm-/Trailing Arm Bush	200 T, 230 T, 230 TE, 240 T D, 250 T, 280 TE, 300 T D, 300 T Turbo-D		<b>G9-588</b>	⊕ ⊕ ⊕ ⊕	H=30; d=16; D=41
Control Arm-/Trailing Arm Bush	200 T		<b>G9-651</b>	⊕ ⊕	d=12
Control Arm-/Trailing Arm Bush	200 T		<b>G9-652</b>	⊕ ⊕ ⊕	d=13
<b>KOMBI Estate (S124)</b>			<b>09/1985 → 07/1993</b>		
Dust Cover Kit, shock absorber	200 T, 200 T D, 220 TE, 230 TE, 250 T D, 300 T D, 300 T Turbo-D 4-matic, 300 TE, 300 TE-24		<b>AK-735019</b>	⊕ ⊕ ⊕	
Engine Mounting	200 T	✱	<b>F7-2003</b>	⊕ ⊕	
Engine Mounting	200 TE, 230 TE	✱	<b>F7-2003</b>	⊕ ⊕	
Engine Mounting	250 T D	✱	<b>F7-2003</b>	⊕ ⊕	
Engine Mounting	250 T D	✱, ✱	<b>F7-2003</b>	⊕ ⊕	
Repair Kit, reversing lever	200 T, 200 T D, 200 TE, 220 TE, 230 TE, 250 T D, 300 T D, 300 T Turbo-D, 300 T Turbo-D 4-matic, 300 TE, 300 TE 4-matic, 300 TE-24		<b>F7-9001</b>	⊕ ⊕	
Engine Mounting	300 T D	09/1989 →	<b>F8-2005</b>	⊕ ⊕ ⊕	
Engine Mounting	300 T Turbo-D	09/1989 →;	<b>F8-2005</b>	⊕ ⊕ ⊕	
Engine Mounting	300 TE	✱, ✱	<b>F8-2005</b>	⊕ ⊕ ⊕	
Mounting, propshaft	200 T, 200 T D, 200 TE, 230 TE, 250 T D	⊕	<b>F8-4002</b>	⊕	H=89; d=43; D=83; τ [mm]=119
Mounting, propshaft	200 T, 200 T D, 200 TE, 230 TE, 250 T D		<b>F8-4003</b>	⊕	H=100; d=50; D=93; τ [mm]=119
Engine Mounting	200 TE, 230 TE	✱	<b>F8-5005</b>	⊕	H=111; D1=90; D2=103
Engine Mounting	250 T D	✱, ✱	<b>F8-5005</b>	⊕	H=111; D1=90; D2=103
Engine Mounting	300 TE	✱, ✱, ✱	<b>F8-5005</b>	⊕	H=111; D1=90; D2=103
Suspension Kit	200 T		<b>F8-5009</b>	⊕ ⊕ ⊕	
Suspension Kit	200 T D, 200 TE, 230 TE, 250 T D, 300 T D, 300 TE, 300 TE-24	ch.→F204091	<b>F8-5009</b>	⊕ ⊕ ⊕	
Control Arm-/Trailing Arm Bush	200 T, 200 T D, 200 TE, 220 TE, 230 TE, 250 T D, 300 T D, 300 TE, 300 TE-24		<b>F8-5010</b>	⊕ ⊕ ⊕ ⊕	H=49; d=16; D1=49; D2=65
Suspension Kit	250 T D	SP	<b>F8-5011</b>	⊕ ⊕ ⊕	
Joint, propshaft	200 T, 200 T D, 200 TE, 250 T D	with add-on material	<b>F8-5015</b>	⊕	d=34; D=128
Joint, propshaft	200 T, 200 T D, 200 TE, 250 T D	Joint Type: Hard Version; with fastening material	<b>F8-5016</b>	⊕	H=26; d=40; Mounting points diam.[mm]=10.2; D=116
Mounting, axle beam	200 T, 200 T D, 200 TE, 220 TE, 230 TE, 250 T D, 300 T D, 300 T Turbo-D 4-matic		<b>F8-5018</b>	⊕	H=58; D1=68; D2=81
Repair Kit, link	250 TD Turbo	ch.→B711095; SP	<b>F8-5185</b>	⊕ ⊕ ⊕ ⊕	

<b>AK-735019</b>	<b>F7-2003</b>	<b>F7-9001</b>	<b>F8-2005</b>	<b>F8-4002</b>	<b>F8-4003</b>	<b>F8-5005</b>
Ref.Nr.: 1293230192	Ref.Nr.: 1242400217	Ref.Nr.: 1234600050	Ref.Nr.: 1242401917	Ref.Nr.: 1244100181	Ref.Nr.: 1244100281	Ref.Nr.: 1242400317
<b>F8-5009</b>	<b>F8-5010</b>	<b>F8-5011</b>	<b>F8-5015</b>	<b>F8-5016</b>	<b>F8-5018</b>	<b>F8-5185</b>
Ref.Nr.: 1243300275	Ref.Nr.: 2013335114	Ref.Nr.: 2013300075	Ref.Nr.: 1244100015	Ref.Nr.: 2014102115	Ref.Nr.: 2013512742	Ref.Nr.: 2013300175
<b>F8-5195</b>	<b>F8-8194</b>	<b>G9-514</b>	<b>G9-588</b>	<b>G9-651</b>	<b>G9-652</b>	
Ref.Nr.: 1243300675	Ref.Nr.: 1232414113	Ref.Nr.: 1163336314	Ref.Nr.: 1163334014	Ref.Nr.: 1243529065	Ref.Nr.: 1243528665	

Article Description



Article Nr.

Fitting Position



<b>KOMBI Estate (S124)</b>		<b>09/1985 → 07/1993</b>	
Suspension Kit	200 TE, 230 TE, 250 T D, 300 T D, 300 T Turbo-D, 300 TE	ch.F204092→; 09/1989 →	<b>F8-5195</b>
Suspension Kit	300 TE-24	ch.F204092→	<b>F8-5195</b>
Stabiliser Mounting	200 T, 200 T D, 200 TE, 220 TE, 230 TE, 250 T D, 300 T D, 300 T Turbo-D, 300 TE, 300 TE-24, 320 TE		<b>F8-5209</b> H=36; d=22.5; D=38
Stabiliser Mounting	200 T, 200 T D, 200 TE, 220 TE, 230 TE, 300 T D, 300 T Turbo-D, 300 TE, 300 TE-24, 320 TE		<b>F8-5216</b> d=28.5
Stabiliser Mounting	250 T D	ch.F042994 →	<b>F8-5216</b> d=28.5
Control Arm-/Trailing Arm Bush	200 T, 200 T D, 200 TE, 220 TE, 230 TE, 250 T D, 260 TE FGST., 280 TE, 300 T D, 300 T Turbo-D, 300 T Turbo-D 4-matic, 300 TE, 300 TE 4-matic, 300 TE-24, 320 TE		<b>F8-5297</b>
Control Arm-/Trailing Arm Bush	200 T, 200 T D, 200 TE, 220 TE, 230 TE, 250 T D, 260 TE FGST., 300 T D, 300 T Turbo-D, 300 TE, 300 TE 4-matic, 300 TE-24, 320 TE		<b>F8-5327</b> d=11; D=36
Engine Mounting	250 T D		<b>F8-5449</b>
Engine Mounting	260 TE FGST., 300 TE		<b>F8-5449</b>
Engine Mounting	300 T D	09/1989 →;	<b>F8-5449</b>
Engine Mounting	300 T Turbo-D		<b>F8-5449</b>
Engine Mounting	300 T Turbo-D, 300 T Turbo-D 4-matic		<b>F8-5449</b>
Top Strut Mounting	200 T, 200 T D, 200 TE, 220 TE, 230 TE, 250 T D, 260 TE FGST., 300 T D, 300 T Turbo-D, 300 T Turbo-D 4-matic, 300 TE, 300 TE-24, 320 TE		<b>F8-5502</b> d=14.5; D=59; Thick. [mm]=130
Stabiliser Mounting	200 T, 200 T D, 200 TE, 230 TE, 250 T D, 250 TD Turbo		<b>F8-5670</b> d=13
Control Arm-/Trailing Arm Bush	200 T, 200 T D, 200 TE, 220 TE, 230 TE, 250 T D, 260 TE FGST., 280 TE, 300 T D, 300 T Turbo-D, 300 TE, 300 TE 4-matic, 300 TE-24, 320 TE		<b>F8-5678</b> H=58; d=12; D=33
Mounting, axle beam	200 T, 200 T D, 200 TE, 230 TE, 250 T D, 250 TD Turbo, 300 T D, 300 T Turbo-D, 300 TE, 300 TE 4-matic, 300 TE-24		<b>F8-5733</b> H=30; d=14; D=47
Mounting, axle beam	200 T, 200 T D, 200 TE, 220 TE, 230 TE, 250 T D, 250 TD Turbo, 260 TE FGST., 280 TE, 300 T D, 300 T Turbo-D, 300 TE, 300 TE 4-matic, 300 TE-24, 320 TE		<b>F8-5744</b>
Mounting, axle beam	200 T, 200 T D, 200 TE, 230 TE, 250 T D, 300 T D, 300 T Turbo-D, 300 TE, 300 TE 4-matic, 300 TE-24		<b>F8-5773</b> H=70; D=70
Repair Set, axle beam	280 TE, 300 TE, 300 TE 4-matic, 300 TE-24		<b>F8-5820</b>
Mounting, axle beam	280 TE, 300 TE, 300 TE 4-matic, 300 TE-24		<b>F8-5821</b> H=59; d=16; D=66
Rubber Buffer, suspension	200 T, 200 T D, 200 TE, 220 TE, 230 TE, 250 T D, 260 TE FGST., 280 TE, 300 T D, 300 T Turbo-D, 300 T Turbo-D 4-matic, 300 TE, 300 TE 4-matic, 300 TE-24, 320 TE		<b>F8-5901</b>





Article Description



Article Nr.

Fitting Position



### KOMBI Estate (S124) 09/1985 → 07/1993

Rubber Buffer, suspension	200 T, 200 T D, 200 TE, 230 TE, 250 T D, 300 T D, 300 T Turbo-D, 300 TE, 300 TE-24		<b>F8-5914</b>		H=75
Rubber Buffer, suspension	200 T, 200 T D, 200 TE, 220 TE, 230 TE, 250 T D, 280 TE, 300 T D, 300 T Turbo-D, 300 TE, 300 TE-24, 320 TE		<b>F8-5918</b>		
Stabiliser Mounting	200 T, 200 T D, 200 TE, 220 TE, 230 TE		<b>F8-5973</b>		H=38,5; d=25; D=45
Repair Set, axle beam	200 T, 200 T D, 200 TE, 220 TE, 230 TE, 250 T D, 250 TD Turbo, 260 TE FGST., 300 T D, 300 T Turbo-D, 300 T Turbo-D 4-matic	with fastening material	<b>F8-6230</b>		
Joint, propshaft	280 TE	with fastening material;	<b>F8-6239</b>		Bolt Hole Circle Ø [mm]=100; d=46; D=140; W=29.8
Joint, propshaft	300 TE-24, 320 TE	with fastening material	<b>F8-6239</b>		Bolt Hole Circle Ø [mm]=100; d=46; D=140; W=29.8
Mounting, manual transmission	200 T, 200 T D, 200 TE, 220 TE, 230 TE, 250 T D, 250 TD Turbo, 260 TE FGST., 280 TE, 300 T D, 300 T Turbo-D, 300 TE, 300 TE 4-matic, 300 TE-24, 320 TE		<b>F8-6498</b>		
Mounting, manual transmission	260 TE FGST.	Type: 124.007	<b>F8-6498</b>		
Joint, propshaft	200 T, 200 T D, 200 TE, 220 TE, 230 TE, 250 T D, 260 TE FGST., 300 T D, 300 TE	with add-on material	<b>F8-7130</b>		Bolt Hole Circle Ø [mm]=90
Control Arm-/Trailing Arm Bush	200 T, 200 T D, 200 TE, 220 TE, 230 TE, 250 T D, 280 TE, 300 T D, 300 T Turbo-D, 300 T Turbo-D 4-matic, 300 TE, 300 TE 4-matic, 300 TE-24, 320 TE		<b>G9-503</b>		H=43; d=12; D=31
Control Arm-/Trailing Arm Bush	200 T, 200 T D, 200 TE, 220 TE, 230 TE, 250 T D, 280 TE, 300 T D, 300 T Turbo-D, 300 T Turbo-D 4-matic, 300 TE, 300 TE 4-matic, 300 TE-24, 320 TE		<b>G9-651</b>		d=12
Control Arm-/Trailing Arm Bush	200 T, 200 T D, 200 TE, 220 TE, 230 TE, 250 T D, 280 TE, 300 T D, 300 T Turbo-D, 300 T Turbo-D 4-matic, 300 TE, 300 TE 4-matic, 300 TE-24, 320 TE		<b>G9-652</b>		d=13

### M-CLASS (W163) 02/1998 → 06/2005

Alternator Freewheel Clutch	ML 270 CDI		<b>F5-1018</b>		
Alternator Freewheel Clutch	ML 400 CDI		<b>F5-1065</b>		
Belt Pulley, crankshaft	All Models	Parameter: 6PK	<b>F8-5663</b>		d=32; D1=160; D2=157; W1=82
Engine Mounting	ML 270 CDI, ML 350, ML 400 CDI		<b>F8-8185</b>		
Engine Mounting	ML 230, ML 270 CDI, ML 320, ML 350		<b>F8-8192</b>		
Engine Mounting	ML 400 CDI, ML 430, ML 55 AMG		<b>F8-8193</b>		
Engine Mounting	ML 270 CDI, ML 400 CDI		<b>F8-8203</b>		

### M-CLASS (W164) 07/2005 → 07/2009

Alternator Freewheel Clutch	ML 280 CDI 4-matic, ML 300 CDI 4-matic, ML 320 CDI 4-matic, ML 350 CDI 4-matic		<b>F5-1065</b>		
Alternator Freewheel Clutch	ML 280 CDI 4-matic, ML 300 CDI 4-matic, ML 320 CDI 4-matic, ML 350 CDI 4-matic		<b>F5-1111</b>		

<b>F5-1018</b>	<b>F5-1065</b>	<b>F5-1111</b>	<b>F5-1114</b>	<b>F8-5663</b>	<b>F8-5914</b>	<b>F8-5918</b>
Ref.Nr.: 6111500360	Ref.Nr.: 6281500060	Ref.Nr.: 6421500760	Ref.Nr.: 6291500060	Ref.Nr.: 1120350800	Ref.Nr.: 1293230744	Ref.Nr.: 1243230744
<b>F8-5973</b>	<b>F8-6230</b>	<b>F8-6239</b>	<b>F8-6498</b>	<b>F8-7130</b>	<b>F8-8185</b>	<b>F8-8192</b>
Ref.Nr.: 1243234485	Ref.Nr.: 1243516408	Ref.Nr.: 1704100015	Ref.Nr.: 1242400018	Ref.Nr.: 1264100515	Ref.Nr.: 1632400218	Ref.Nr.: 1632400217
<b>F8-8193</b>	<b>F8-8203</b>	<b>G9-503</b>	<b>G9-651</b>	<b>G9-652</b>		
Ref.Nr.: 1632400317	Ref.Nr.: 1632400417	Ref.Nr.: 1243524365	Ref.Nr.: 1243529065	Ref.Nr.: 1243528665		

Article Description



Article Nr.

Fitting Position



<b>M-CLASS (W164)</b>		<b>07/2005 → 07/2009</b>	
Alternator Freewheel Clutch	ML 280 CDI 4-matic, ML 300 CDI 4-matic, ML 320 CDI 4-matic, ML 350 CDI 4-matic	F5-1114	
Alternator Freewheel Clutch	ML 280 CDI 4-matic, ML 300 CDI 4-matic, ML 320 CDI 4-matic, ML 350 CDI 4-matic	F5-1126	
Belt Pulley, crankshaft	ML 500 4-matic	Parameter: 6PK	F8-5663 d=32; D1=160; D2=157; W1=82
<b>R-CLASS (W251, V251)</b>		<b>01/2006 →</b>	
Alternator Freewheel Clutch	R 280 CDI, R 280 CDI 4-matic, R 300 CDI, R 300 CDI 4-matic, R 320 CDI 4-matic, R 350 CDI 4-matic	F5-1065	
Alternator Freewheel Clutch	R 280 CDI, R 280 CDI 4-matic, R 300 CDI, R 300 CDI 4-matic, R 320 CDI 4-matic, R 350 CDI 4-matic	F5-1111	
Alternator Freewheel Clutch	R 280 CDI 4-matic, R 300 CDI 4-matic, R 320 CDI 4-matic, R 350 CDI 4-matic	F5-1114	
Alternator Freewheel Clutch	R 280 CDI, R 280 CDI 4-matic, R 300 CDI, R 300 CDI 4-matic, R 320 CDI 4-matic, R 350 CDI 4-matic	F5-1126	
Belt Pulley, crankshaft	R 500 4-matic	Parameter: 6PK	F8-5663 d=32; D1=160; D2=157; W1=82
<b>S-CLASS (W108, W109)</b>		<b>10/1967 → 08/1972</b>	
Repair Kit, reversing lever	300 SEL, 300 SEL 3.5, 300 SEL 6.3	F7-9001	
Joint, propshaft	280 S, 280 SE,SEL, 280 SE,SEL 3.5, 300 SEL	F8-6235	Bolt Hole Circle Ø [mm]=90
<b>S-CLASS (W116)</b>		<b>08/1972 → 07/1980</b>	
Repair Kit, reversing lever	280 S, 280 SE,SEL, 350 SE,SEL, 450 SE,SEL, 450 SEL 6.9	F7-9001	
Mounting, propshaft	280 S, 280 SE,SEL, 350 SE,SEL, 450 SE,SEL, 450 SEL 6.9	F8-4001	H=108; d=55; D=95; T [mm]=128
Control Arm-/Trailing Arm Bush	450 SE,SEL, 450 SEL 6.9	F8-4005	H=64.5; d=16.4; D1=42; D2=53
Suspension Kit	280 S, 280 SE,SEL, 350 SE,SEL, 450 SE,SEL, 450 SEL 6.9	F8-5020	
Repair Set, axle beam	4.5, 450 SE,SEL, 450 SEL 6.9	F8-5730	d=16; L=65; D=54
Rubber Buffer, suspension	280 S, 280 SE,SEL, 350 SE,SEL, 4.5, 450 SE,SEL, 450 SEL 6.9	F8-5770	H=63
Joint, propshaft	280 S, 280 SE,SEL, 350 SE,SEL	F8-6235	Bolt Hole Circle Ø [mm]=90
Control Arm-/Trailing Arm Bush	280 S, 280 SE,SEL, 350 SE,SEL, 450 SE,SEL, 450 SEL 6.9	G9-514	H=33; d=12; D1=43; D2=51
Control Arm-/Trailing Arm Bush	280 S, 280 SE,SEL, 350 SE,SEL, 450 SE,SEL, 450 SEL 6.9	G9-588	H=30; d=16; D=41
<b>S-CLASS (W126)</b>		<b>10/1979 → 06/1991</b>	
Repair Kit, reversing lever	260 SE, 280 S, 280 SE,SEL, 300 SE,SEL, 380 SE,SEL, 420 SE,SEL, 500 SE,SEL, 560 SE,SEL	F7-9001	
Control Arm-/Trailing Arm Bush	260 SE, 280 S, 280 SE,SEL, 300 SE,SEL, 380 SE,SEL, 420 SE,SEL, 500 SE,SEL, 560 SE,SEL	F8-4005	H=64.5; d=16.4; D1=42; D2=53
Mounting, propshaft	280 S, 280 SE,SEL, 380 SE,SEL, 500 SE,SEL	F8-4006	H=100; d=55; D=94; T [mm]=119

<b>F5-1065</b>	<b>F5-1111</b>	<b>F5-1114</b>	<b>F5-1126</b>	<b>F7-9001</b>	<b>F8-4001</b>	<b>F8-4005</b>
Ref.Nr.: 6281500060	Ref.Nr.: 6421500760	Ref.Nr.: 6291500060	Ref.Nr.: 05175811AA	Ref.Nr.: 1234600050	Ref.Nr.: 1164102781	Ref.Nr.: 1153523265
<b>F8-4006</b>	<b>F8-5020</b>	<b>F8-5120</b>	<b>F8-5663</b>	<b>F8-5730</b>	<b>F8-5770</b>	<b>F8-6235</b>
Ref.Nr.: 1264100181	Ref.Nr.: 1165860133	Ref.Nr.: 1263230185	Ref.Nr.: 1120350800	Ref.Nr.: 1153523665	Ref.Nr.: 1153200344	Ref.Nr.: 1264100215
<b>G9-514</b>	<b>G9-588</b>					
Ref.Nr.: 1163336314	Ref.Nr.: 1163334014					

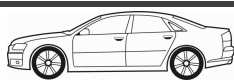
**Article Description****Article Nr.****Fitting Position**

<b>S-CLASS (W126)</b>		<b>10/1979 → 06/1991</b>	
Stabiliser Mounting	260 SE , 280 S , 280 SE,SEL , 300 SE,SEL , 380 SE,SEL , 420 SE,SEL , 500 SE,SEL , 560 SE,SEL	<b>F8-5120</b>	d=24.5
Control Arm-/Trailing Arm Bush	All Models	<b>F8-5131</b>	H=66.5; d=13.5; D=85; D1=73.5; D2=71.3
Suspension Kit	260 SE , 280 S , 280 SE,SEL , 300 SE,SEL , 380 SE,SEL , 420 SE,SEL , 500 SE,SEL , 560 SE,SEL	<b>F8-5256</b>	
Repair Set, axle beam	260 SE , 280 S , 280 SE,SEL , 300 SE,SEL , 380 SE,SEL , 420 SE,SEL , 500 SE,SEL , 500 SE,SEL CAT , 560 SE,SEL	<b>F8-5730</b>	d=16; L=65; D=54
Repair Set, axle beam	280 S , 280 SE,SEL , 380 SE,SEL , 500 SE,SEL	<b>F8-5767</b>	
Rubber Buffer, suspension	All Models	<b>F8-5770</b>	H=63
Joint, propshaft	280 S , 280 SE,SEL , 380 SE,SEL	<b>F8-6235</b>	Bolt Hole Circle Ø [mm]=90
Joint, propshaft	260 SE , 300 SE,SEL	<b>F8-7130</b>	with add-on material Bolt Hole Circle Ø [mm]=90
Control Arm-/Trailing Arm Bush	260 SE , 280 S , 280 SE,SEL , 300 SE,SEL , 380 SE,SEL , 420 SE,SEL , 500 SE,SEL , 500 SE,SEL CAT , 560 SE,SEL	<b>G9-544</b>	H=40; d=12; D=62
Control Arm-/Trailing Arm Bush	260 SE , 280 S , 280 SE,SEL , 300 SE,SEL , 380 SE,SEL , 420 SE,SEL , 500 SE,SEL , 500 SE,SEL CAT , 560 SE,SEL	<b>G9-588</b>	H=30; d=16; D=41
Control Arm-/Trailing Arm Bush	500 SE,SEL , 500 SE,SEL CAT	<b>G9-651</b>	d=12
Control Arm-/Trailing Arm Bush	500 SE,SEL , 500 SE,SEL CAT	<b>G9-652</b>	d=13
<b>S-CLASS Coupe (C126)</b>		<b>10/1981 → 06/1991</b>	
Repair Kit, reversing lever	380 SEC , 420 SEC , 500 SEC , 560 SEC	<b>F7-9001</b>	
Control Arm-/Trailing Arm Bush	380 SEC , 420 SEC , 500 SEC , 560 SEC	<b>F8-4005</b>	H=64.5; d=16.4; D1=42; D2=53
Stabiliser Mounting	380 SEC , 420 SEC , 500 SEC , 560 SEC	<b>F8-5120</b>	d=24.5
Control Arm-/Trailing Arm Bush	380 SEC , 420 SEC , 500 SEC , 500 SEC CAT , 560 SEC	<b>F8-5131</b>	H=66.5; d=13.5; D=85; D1=73.5; D2=71.3
Suspension Kit	380 SEC , 420 SEC , 500 SEC , 560 SEC	<b>F8-5256</b>	
Repair Set, axle beam	380 SEC , 420 SEC , 500 SEC , 500 SEC CAT , 560 SEC	<b>F8-5730</b>	d=16; L=65; D=54
Repair Set, axle beam	380 SEC , 500 SEC	<b>F8-5767</b>	
Rubber Buffer, suspension	380 SEC , 420 SEC , 500 SEC , 500 SEC CAT , 560 SEC	<b>F8-5770</b>	H=63
Control Arm-/Trailing Arm Bush	380 SEC , 420 SEC , 500 SEC , 500 SEC CAT , 560 SEC	<b>G9-544</b>	H=40; d=12; D=62
Control Arm-/Trailing Arm Bush	380 SEC , 420 SEC , 500 SEC , 500 SEC CAT , 560 SEC	<b>G9-588</b>	H=30; d=16; D=41
Control Arm-/Trailing Arm Bush	500 SEC , 500 SEC CAT	<b>G9-651</b>	d=12

<b>F7-9001</b>	<b>F8-4005</b>	<b>F8-5120</b>	<b>F8-5131</b>	<b>F8-5256</b>	<b>F8-5730</b>	<b>F8-5767</b>
Ref.Nr.: 1234600050	Ref.Nr.: 1153523265	Ref.Nr.: 1263230185	Ref.Nr.: 1263333014	Ref.Nr.: 1263300075	Ref.Nr.: 1153523665	Ref.Nr.: 1263500175
<b>F8-5770</b>	<b>F8-6235</b>	<b>F8-7130</b>	<b>G9-544</b>	<b>G9-588</b>	<b>G9-651</b>	<b>G9-652</b>
Ref.Nr.: 1153200344	Ref.Nr.: 1264100215	Ref.Nr.: 1264100515	Ref.Nr.: 1243333814	Ref.Nr.: 1163334014	Ref.Nr.: 1243529065	Ref.Nr.: 1243528665

Article Description



Article Nr.

Fitting Position



<b>S-CLASS Coupe (C126)</b>				<b>10/1981 → 06/1991</b>	
Control Arm-/Trailing Arm Bush	500 SEC , 500 SEC CAT		<b>G9-652</b>		d=13
<b>S-CLASS (W140)</b>				<b>02/1991 → 10/1998</b>	
Alternator Freewheel Clutch	S 300 Turbo-D		<b>F5-1003</b>		
Engine Mounting	400 SE,SEL/S420 , 500 SE,SEL , S 420 , S 500		<b>F8-5004</b>		H=105; d=8; D=118; T [mm]=149
Stabiliser Mounting	300 SE,SEL/S320 , 400 SE,SEL/S420 , 500 SE,SEL , 600 SE,SEL , S 280 , S 350 Turbo-D , S 420 , S 500 , S 600	ch.061062→	<b>F8-5113</b>		H=65; d=28; D=46
Stabiliser Mounting	300 SE,SEL/S320 , 400 SE,SEL/S420 , 500 SE,SEL , 600 SE,SEL , S 500 , S 600	ch.→061062	<b>F8-5149</b>		d=26; D=65
Suspension Kit	300 SE,SEL/S320 , 400 SE,SEL/S420 , 500 SE,SEL , 600 SE,SEL , S 280 , S 350 Turbo-D , S 420 , S 500 , S 600		<b>F8-5176</b>		
Stabiliser Mounting	300 SE,SEL/S320 , 400 SE,SEL/S420 , 500 SE,SEL , 600 SE,SEL , S 500 , S 600		<b>F8-5229</b>		d=30
Control Arm-/Trailing Arm Bush	All Models		<b>F8-5297</b>		H=48; d=14.1; D=40.03
Control Arm-/Trailing Arm Bush	All Models		<b>F8-5679</b>		H=58; d=12; D=51
Mounting, axle beam	All Models		<b>F8-5874</b>		H=32; d=12; D=66
Mounting, axle bracket	500 SE,SEL , 600 SE,SEL , S 500 , S 600		<b>F8-5974</b>		
Mounting, axle bracket	300 SE 2.8 , 300 SE,SEL/S320 , 500 SE,SEL , 600 SE,SEL , S 280 , S 300 Turbo-D , S 350 Turbo-D , S 500 , S 600		<b>F8-5975</b>		
Mounting, axle bracket	300 SE 2.8 , 300 SE,SEL/S320 , S 280 , S 300 Turbo-D , S 350 Turbo-D		<b>F8-5978</b>		
Joint, propshaft	300 SE 2.8 , S 280	ch.→A328810; with fastening material;	<b>F8-6239</b>		Bolt Hole Circle Ø [mm]=100; d=46; D=140; W=29.8
Joint, propshaft	300 SE 2.8 , S 280	with fastening material	<b>F8-6239</b>		Bolt Hole Circle Ø [mm]=100; d=46; D=140; W=29.8
Joint, propshaft	300 SE,SEL/S320	06/1996 →; with fastening material	<b>F8-6239</b>		Bolt Hole Circle Ø [mm]=100; d=46; D=140; W=29.8
Joint, propshaft	300 SE,SEL/S320	ch.→A328810; with fastening material	<b>F8-6239</b>		Bolt Hole Circle Ø [mm]=100; d=46; D=140; W=29.8
Control Arm-/Trailing Arm Bush	All Models		<b>F8-6811</b>		d=12.1; D=41.5
Control Arm-/Trailing Arm Bush	All Models		<b>F8-6812</b>		d=12.1; D=38.5
Repair Kit, reversing lever	All Models	with add-on material	<b>F8-7103</b>		
Control Arm-/Trailing Arm Bush	All Models		<b>F8-7876</b>		
Control Arm-/Trailing Arm Bush	All Models		<b>F8-8127</b>		

<b>F5-1003</b>	<b>F8-5004</b>	<b>F8-5113</b>	<b>F8-5149</b>	<b>F8-5176</b>	<b>F8-5229</b>	<b>F8-5297</b>
Ref.Nr.: 6041500060	Ref.Nr.: 1292400917	Ref.Nr.: 1403231085	Ref.Nr.: 1403230985	Ref.Nr.: 1403306007	Ref.Nr.: 1403231485	Ref.Nr.: 2043520027
<b>F8-5679</b>	<b>F8-5874</b>	<b>F8-5974</b>	<b>F8-5975</b>	<b>F8-5978</b>	<b>F8-6239</b>	<b>F8-6811</b>
Ref.Nr.: 1403528065	Ref.Nr.: 1293510742	Ref.Nr.: 1403311444	Ref.Nr.: 1403311544	Ref.Nr.: 1403312244	Ref.Nr.: 1704100015	Ref.Nr.: 1403524465
<b>F8-6812</b>	<b>F8-7103</b>	<b>F8-7876</b>	<b>F8-8127</b>	<b>F8-8128</b>	<b>G9-652</b>	
Ref.Nr.: 1403524665	Ref.Nr.: 1404600819	Ref.Nr.: 1403331814	Ref.Nr.: 1403331714	Ref.Nr.: 1403524565	Ref.Nr.: 1243528665	





Article Description



Article Nr.

Fitting Position



<b>S-CLASS (W140)</b>				<b>02/1991 → 10/1998</b>	
Control Arm-/Trailing Arm Bush	All Models		<b>F8-8128</b>		
Control Arm-/Trailing Arm Bush	S 500		<b>G9-651</b>		d=12
Control Arm-/Trailing Arm Bush	500 SE,SEL , S 500		<b>G9-652</b>		d=13
<b>S-CLASS Coupe (C140)</b>				<b>09/1992 → 02/1999</b>	
Engine Mounting	SEC/CL 500		<b>F8-5004</b>		H=105; d=8; D=118; T [mm]=149
Stabiliser Mounting	SEC/CL 500 , SEC/CL 600	ch.061062→	<b>F8-5113</b>		H=65; d=28; D=46
Stabiliser Mounting	SEC/CL 420 , SEC/CL 500 , SEC/CL 600	ch.→061062	<b>F8-5149</b>		d=26; D=65
Suspension Kit	SEC/CL 500 , SEC/CL 600		<b>F8-5176</b>		
Stabiliser Mounting	SEC/CL 420 , SEC/CL 500 , SEC/CL 600		<b>F8-5229</b>		d=30
Control Arm-/Trailing Arm Bush	SEC/CL 420 , SEC/CL 500 , SEC/CL 600		<b>F8-5297</b>		H=48; d=14.1; D=40.03
Control Arm-/Trailing Arm Bush	SEC/CL 420 , SEC/CL 500 , SEC/CL 600		<b>F8-5679</b>		H=58; d=12; D=51
Mounting, axle beam	SEC/CL 420 , SEC/CL 500 , SEC/CL 600		<b>F8-5874</b>		H=32; d=12; D=66
Control Arm-/Trailing Arm Bush	SEC/CL 420 , SEC/CL 500 , SEC/CL 600		<b>F8-6811</b>		d=12.1; D=41.5
Control Arm-/Trailing Arm Bush	SEC/CL 420 , SEC/CL 500 , SEC/CL 600		<b>F8-6812</b>		d=12.1; D=38.5
Repair Kit, reversing lever	SEC/CL 420 , SEC/CL 500 , SEC/CL 600	with add-on material	<b>F8-7103</b>		
Control Arm-/Trailing Arm Bush	SEC/CL 420 , SEC/CL 500 , SEC/CL 600		<b>F8-7876</b>		
Control Arm-/Trailing Arm Bush	SEC/CL 420 , SEC/CL 500 , SEC/CL 600		<b>F8-8127</b>		
Control Arm-/Trailing Arm Bush	SEC/CL 420 , SEC/CL 500 , SEC/CL 600		<b>F8-8128</b>		
Control Arm-/Trailing Arm Bush	SEC/CL 500		<b>G9-651</b>		d=12
Control Arm-/Trailing Arm Bush	SEC/CL 500		<b>G9-652</b>		d=13
<b>S-CLASS (W220)</b>				<b>10/1998 → 08/2005</b>	
Alternator Freewheel Clutch	S 320 CDI		<b>F5-1018</b>		
Alternator Freewheel Clutch	S 400 CDI		<b>F5-1042</b>		
Alternator Freewheel Clutch	S 320 CDI		<b>F5-1058</b>		
Alternator Freewheel Clutch	S 400 CDI		<b>F5-1065</b>		
Belt Pulley, crankshaft	All Models	Parameter: 6PK	<b>F8-5663</b>		d=32; D1=160; D2=157; W1=82
Mounting, axle beam	All Models		<b>F8-6182</b>		H=78; d=12; D=51.5

<b>F5-1018</b>	<b>F5-1042</b>	<b>F5-1058</b>	<b>F5-1065</b>	<b>F8-5004</b>	<b>F8-5113</b>	<b>F8-5149</b>
Ref.Nr.: 6111500360	Ref.Nr.: 6281550015	Ref.Nr.: 6461500260	Ref.Nr.: 6281500060	Ref.Nr.: 1292400917	Ref.Nr.: 1403231085	Ref.Nr.: 1403230985
<b>F8-5176</b>	<b>F8-5229</b>	<b>F8-5297</b>	<b>F8-5663</b>	<b>F8-5679</b>	<b>F8-5874</b>	<b>F8-6182</b>
Ref.Nr.: 1403306007	Ref.Nr.: 1403231485	Ref.Nr.: 2043520027	Ref.Nr.: 1120350800	Ref.Nr.: 1403528065	Ref.Nr.: 1293510742	Ref.Nr.: 2203521365
<b>F8-6652</b>	<b>F8-6811</b>	<b>F8-6812</b>	<b>F8-7103</b>	<b>F8-7876</b>	<b>F8-8127</b>	<b>F8-8128</b>
Ref.Nr.: 2203308607	Ref.Nr.: 1403524465	Ref.Nr.: 1403524665	Ref.Nr.: 1404600819	Ref.Nr.: 1403331814	Ref.Nr.: 1403331714	Ref.Nr.: 1403524565

Article Description



Article Nr.

Fitting Position



<b>S-CLASS (W220)</b>			<b>10/1998 → 08/2005</b>	
Mounting, axle beam	S 280 , S 320 , S 320 CDI , S 350 , S 400 CDI , S 430 , S 500 , S 55 AMG , S 55 AMG Kompressor , S 600 , S 63 AMG, S 65 AMG	with accessories	<b>F8-6652</b>	
Joint, propshaft	S 430 , S 500	with fastening material; 7-speed	<b>F8-6760</b>	d=57.5; D=145; Thick./Strength 1 [mm]=31.5
Control Arm-/Trailing Arm Bush	S 280	⊗; Type: 220.063, 220.163	<b>F8-6812</b>	d=12.1; D=38.5
Control Arm-/Trailing Arm Bush	S 320	⊗; Type: 220.065, 220.165	<b>F8-6812</b>	d=12.1; D=38.5
Control Arm-/Trailing Arm Bush	S 320 CDI	⊗; Type: 220.025, 220.125	<b>F8-6812</b>	d=12.1; D=38.5
Control Arm-/Trailing Arm Bush	S 320 CDI	⊗; Type: 220.026, 220.126	<b>F8-6812</b>	d=12.1; D=38.5
Control Arm-/Trailing Arm Bush	S 350	⊗; Type: 220.067, 220.167	<b>F8-6812</b>	d=12.1; D=38.5
Control Arm-/Trailing Arm Bush	S 350 4-matic	⊗; Type: 220.087, 220.187	<b>F8-6812</b>	d=12.1; D=38.5
Control Arm-/Trailing Arm Bush	S 400 CDI	⊗; Type: 220.028, 220.128	<b>F8-6812</b>	d=12.1; D=38.5
Control Arm-/Trailing Arm Bush	S 430	⊗; Type: 220.070, 220.170	<b>F8-6812</b>	d=12.1; D=38.5
Control Arm-/Trailing Arm Bush	S 430 4-matic	⊗; Type: 220.083, 220.183	<b>F8-6812</b>	d=12.1; D=38.5
Control Arm-/Trailing Arm Bush	S 500	⊗; Type: 220.075, 220.175	<b>F8-6812</b>	d=12.1; D=38.5
Control Arm-/Trailing Arm Bush	S 500 4-matic	⊗; Type: 220.084, 220.184	<b>F8-6812</b>	d=12.1; D=38.5
Control Arm-/Trailing Arm Bush	S 55 AMG	⊗; Type: 220.073, 220.173	<b>F8-6812</b>	d=12.1; D=38.5
Control Arm-/Trailing Arm Bush	S 55 AMG Kompressor	⊗; Type: 220.074, 220.174	<b>F8-6812</b>	d=12.1; D=38.5
Control Arm-/Trailing Arm Bush	S 600	⊗; Type: 220.178	<b>F8-6812</b>	d=12.1; D=38.5
Control Arm-/Trailing Arm Bush	S 280 , S 320 , S 320 CDI , S 350 , S 350 4-matic , S 400 CDI , S 430 , S 430 4-matic , S 500 , S 500 4-matic , S 55 AMG		<b>F8-8128</b>	
Control Arm-/Trailing Arm Bush	S 500		<b>G9-651</b>	d=12
Control Arm-/Trailing Arm Bush	S 500		<b>G9-652</b>	d=13
<b>S-CLASS Coupe (C215)</b>			<b>03/1999 → 03/2006</b>	
Belt Pulley, crankshaft	CL 500	Parameter: 6PK	<b>F8-5663</b>	d=32; D1=160; D2=157; W1=82
Mounting, axle beam	All Models		<b>F8-6182</b>	H=78; d=12; D=51.5
Mounting, manual transmission	CL 600		<b>F8-6498</b>	

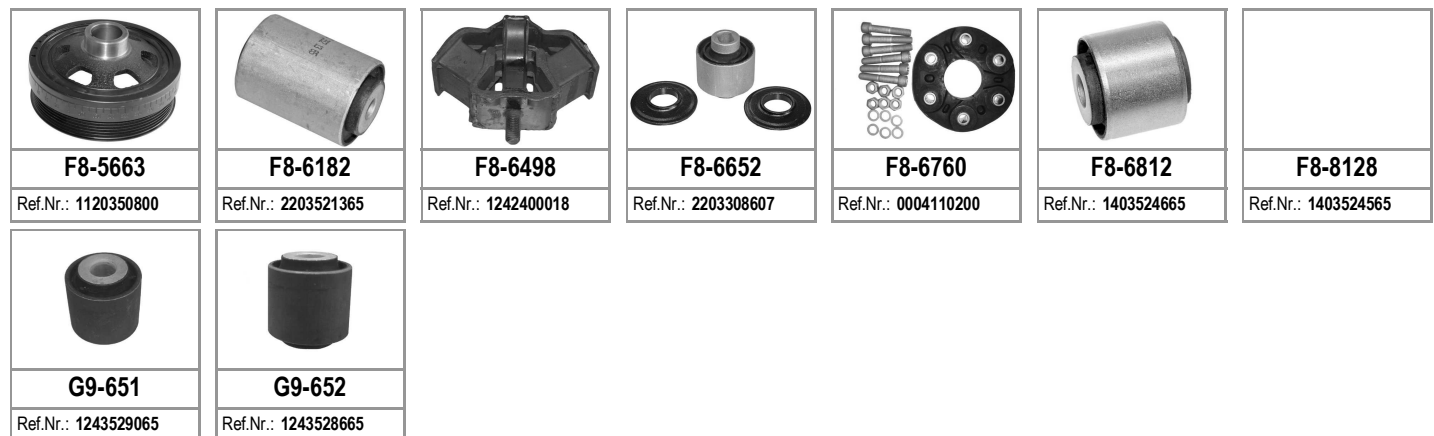



Article Description

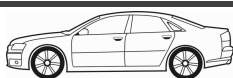

Article Nr.

Fitting Position



S-CLASS Coupe (C215)			03/1999 → 03/2006		
Mounting, axle beam	All Models	with accessories	<b>F8-6652</b>		
Joint, propshaft	CL 500	with fastening material;  7-speed	<b>F8-6760</b>		d=57.5; D=145; Thick./Strength 1 [mm]=31.5
S-CLASS (W221)			10/2005 → 12/2013		
Alternator Freewheel Clutch	S 320 CDI / S 350 CDI , S 320 CDI 4-matic , S 350 BlueTec , S 350 BlueTEC 4-matic		<b>F5-1065</b>		
Alternator Freewheel Clutch	S 350 CDI	Alternator Charge Current [A]: 220; for OE: 0141541302; Manufacturer Restriction: Bosch	<b>F5-1065</b>		
Alternator Freewheel Clutch	S 320 CDI / S 350 CDI , S 320 CDI 4-matic , S 350 CDI		<b>F5-1114</b>		
Mounting, axle beam	S 320 CDI / S 350 CDI , S 420 CDI / S 450 CDI , S 500 , S 600 , S 63 AMG , S 65 AMG		<b>F8-6182</b>		H=78; d=12; D=51.5
Joint, propshaft	S 350	with fastening material;  7-speed	<b>F8-6760</b>		d=57.5; D=145; Thick./Strength 1 [mm]=31.5
Control Arm-/Trailing Arm Bush	S 320 CDI / S 350 CDI , S 320 CDI 4-matic , S 350 , S 350 4-matic , S 400 Hybrid , S 420 CDI / S 450 CDI , S 450 , S 450 4-matic , S 500 , S 500 4-matic , S 600 , S 63 AMG , S 65 AMG		<b>F8-7377</b>		
Control Arm-/Trailing Arm Bush	S 250 CDI , S 320 CDI / S 350 CDI , S 320 CDI 4-matic , S 350 , S 350 4-matic , S 350 BlueTec , S 350 BlueTEC 4-matic , S 350 CGI , S 350 CGI 4-matic , S 400 Hybrid , S 420 CDI / S 450 CDI , S 450 , S 450 4-matic , S 500 , S 500 4-matic , S 500 CGI , S 50	Aluminium	<b>F8-7665</b>		H=37.8; d=12.2; D=39.6
Control Arm-/Trailing Arm Bush	S 250 CDI , S 320 CDI / S 350 CDI , S 320 CDI 4-matic , S 350 , S 350 4-matic , S 350 BlueTec , S 350 BlueTEC 4-matic , S 350 CGI , S 350 CGI 4-matic , S 400 Hybrid , S 420 CDI / S 450 CDI , S 450 , S 450 4-matic , S 500 , S 500 4-matic , S 500 CGI , S 50	Aluminium	<b>F8-7666</b>		
Control Arm-/Trailing Arm Bush	S 250 CDI , S 320 CDI / S 350 CDI , S 320 CDI 4-matic , S 350 , S 350 4-matic , S 350 BlueTec , S 350 BlueTEC 4-matic , S 350 CGI , S 350 CGI 4-matic , S 400 Hybrid , S 420 CDI / S 450 CDI , S 450 , S 450 4-matic , S 500 , S 500 4-matic , S 500 CGI , S 50	Aluminium	<b>F8-7667</b>		
Control Arm-/Trailing Arm Bush	S 250 CDI , S 320 CDI / S 350 CDI , S 320 CDI 4-matic , S 350 , S 350 4-matic , S 350 BlueTec , S 350 BlueTEC 4-matic , S 350 CGI , S 350 CGI 4-matic , S 400 Hybrid , S 420 CDI / S 450 CDI , S 450 , S 450 4-matic , S 500 , S 500 4-matic , S 500 CGI , S 50	Aluminium	<b>F8-7668</b>		
Control Arm-/Trailing Arm Bush	S 250 CDI , S 320 CDI / S 350 CDI , S 320 CDI 4-matic , S 350 , S 350 4-matic , S 350 BlueTec , S 350 BlueTEC 4-matic , S 350 CGI , S 350 CGI 4-matic , S 400 Hybrid , S 420 CDI / S 450 CDI , S 450 , S 450 4-matic , S 500 , S 500 4-matic , S 500 CGI , S 50	Aluminium	<b>F8-7669</b>		

<b>F5-1065</b>	<b>F5-1114</b>	<b>F8-6182</b>	<b>F8-6652</b>	<b>F8-6760</b>	<b>F8-7377</b>	<b>F8-7665</b>
Ref.Nr.: 6281500060	Ref.Nr.: 6291500060	Ref.Nr.: 2203521365	Ref.Nr.: 2203308607	Ref.Nr.: 0004110200	Ref.Nr.: 2213330714	Ref.Nr.: 2213500706
<b>F8-7666</b>	<b>F8-7667</b>	<b>F8-7668</b>	<b>F8-7669</b>	<b>F8-7670</b>		
Ref.Nr.: 2213500406	Ref.Nr.: 2213521165	Ref.Nr.: 2213521265	Ref.Nr.: 2213501153	Ref.Nr.: 2213501153		

Article Description



Article Nr.

Fitting Position



<b>S-CLASS (W221)</b>		<b>10/2005 → 12/2013</b>	
Control Arm-/Trailing Arm Bush	S 250 CDI , S 320 CDI / S 350 CDI , S 320 CDI 4-matic , S 350 , S 350 4-matic , S 350 BlueTec , S 350 BlueTEC 4-matic , S 350 CGI , S 350 CGI 4-matic , S 400 Hybrid , S 420 CDI / S 450 CDI , S 450 , S 450 4-matic , S 500 , S 500 4-matic , S 500 CGI , S 50	Aluminium	F8-7670
Control Arm-/Trailing Arm Bush	S 250 CDI , S 320 CDI / S 350 CDI , S 320 CDI 4-matic , S 350 , S 350 4-matic , S 350 BlueTec , S 350 BlueTEC 4-matic , S 350 CGI , S 350 CGI 4-matic , S 400 Hybrid , S 420 CDI / S 450 CDI , S 450 , S 450 4-matic , S 500 , S 500 4-matic , S 500 CGI , S 50		F8-8087  H=80; d=14; W=70,5
Bellow, driveshaft	S 320 CDI 4-matic , S 350 4-matic , S 350 BlueTEC 4-matic , S 350 CGI 4-matic , S 450 4-matic , S 500 4-matic , S 500 CGI 4-matic		M-871000
Bellow Set, drive shaft	S 320 CDI 4-matic , S 350 4-matic , S 350 BlueTEC 4-matic , S 350 CGI 4-matic , S 450 4-matic , S 500 4-matic , S 500 CGI 4-matic		MK-871000
<b>S-CLASS Coupe (C216)</b>		<b>05/2006 → 12/2013</b>	
Mounting, axle beam	CL 500 , CL 600 , CL 63 AMG		F8-6182  H=78; d=12; D=51.5
Control Arm-/Trailing Arm Bush	CL 500 , CL 500 4-matic , CL 600 , CL 63 AMG , CL 65 AMG		F8-7377
Control Arm-/Trailing Arm Bush	CL 500 , CL 500 4-matic , CL 63 AMG	Aluminium	F8-7665  H=37.8; d=12.2; D=39.6
Control Arm-/Trailing Arm Bush	CL 500 , CL 500 4-matic , CL 63 AMG	Aluminium	F8-7666
Control Arm-/Trailing Arm Bush	CL 500 , CL 500 4-matic , CL 63 AMG	Aluminium	F8-7667
Control Arm-/Trailing Arm Bush	CL 500 , CL 500 4-matic , CL 63 AMG	Aluminium	F8-7668
Control Arm-/Trailing Arm Bush	CL 500 , CL 500 4-matic , CL 600 , CL 63 AMG , CL 65 AMG	Aluminium	F8-7669
Control Arm-/Trailing Arm Bush	CL 500 , CL 500 4-matic , CL 600 , CL 63 AMG , CL 65 AMG	Aluminium	F8-7670
<b>SL (R107)</b>		<b>05/1971 → 08/1989</b>	
Repair Kit, reversing lever	280 SL , 300 SL , 350 SL , 380 SL , 420 SL , 450 SL , 500 SL		F7-9001
Mounting, propshaft	280 SL , 350 SL , 380 SL , 500 SL		F8-4001 H=108; d=55; D=95; T [mm]=128
Control Arm-/Trailing Arm Bush	280 SL , 300 SL , 350 SL , 380 SL , 420 SL , 500 SL		F8-4005  H=64.5; d=16.4; D1=42; D2=53
Control Arm-/Trailing Arm Bush	280 SL , 300 SL , 350 SL , 380 SL , 420 SL , 450 SL , 500 SL		F8-5688  d=12; D=47; W=28.5
Mounting, axle beam	280 SL , 300 SL , 350 SL , 380 SL , 420 SL , 450 SL , 500 SL		F8-5720
Repair Set, axle beam	280 SL , 300 SL , 350 SL , 380 SL , 420 SL , 450 SL , 500 SL		F8-5730  d=16; L=65; D=54

<b>F7-9001</b>	<b>F8-4001</b>	<b>F8-4005</b>	<b>F8-5688</b>	<b>F8-5720</b>	<b>F8-5730</b>	<b>F8-5770</b>
Ref.Nr.: 1234600050	Ref.Nr.: 1164102781	Ref.Nr.: 1153523265	Ref.Nr.: 1153333014	Ref.Nr.: 1073300275	Ref.Nr.: 1153523665	Ref.Nr.: 1153200344
<b>F8-6182</b>	<b>F8-7377</b>	<b>F8-7665</b>	<b>F8-7666</b>	<b>F8-7667</b>	<b>F8-7668</b>	<b>F8-7669</b>
Ref.Nr.: 2203521365	Ref.Nr.: 2213330714	Ref.Nr.: 2213500706	Ref.Nr.: 2213500406	Ref.Nr.: 2213521165	Ref.Nr.: 2213521265	Ref.Nr.: 2213501153
<b>F8-7670</b>	<b>F8-8087</b>	<b>M-871000</b>	<b>MK-871000</b>			
Ref.Nr.: 2213501153	Ref.Nr.: 2213330814	Ref.Nr.: 2213300285	Ref.Nr.: A2213300285			

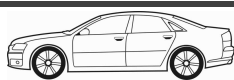
**Article Description****Article Nr.****Fitting Position**

<b>SL (R107)</b>				<b>05/1971 → 08/1989</b>	
Rubber Buffer, suspension	280 SL, 300 SL, 350 SL, 380 SL, 420 SL, 450 SL		<b>F8-5770</b>		H=63
Joint, propshaft	280 SL, 350 SL, 380 SL		<b>F8-6235</b>		Bolt Hole Circle Ø [mm]=90
<b>SL (R129)</b>				<b>03/1989 → 10/2001</b>	
Engine Mounting	500, 500 SL		<b>F8-5004</b>		H=105; d=8; D=118; T [mm]=149
Suspension Kit	300 SL, 300 SL-24	ch.→F049045	<b>F8-5009</b>		
Suspension Kit	320	06/1998 →	<b>F8-5009</b>		
Suspension Kit	500 SL, 60 AMG		<b>F8-5009</b>		
Suspension Kit	280	ch.F049046→;  M 112.923	<b>F8-5195</b>		
Suspension Kit	280, 300 SL-24, 320, 500	ch.F049046→	<b>F8-5195</b>		
Suspension Kit	500	ch.F049046→;  M 119.972	<b>F8-5195</b>		
Suspension Kit	600	ch.F049046→;  M 120.983	<b>F8-5195</b>		
Stabiliser Mounting	280, 300 SL, 300 SL-24, 320, 500, 500 SL		<b>F8-5214</b>		d=18
Stabiliser Mounting	280, 320, 500	06/1998 →	<b>F8-5214</b>		d=18
Stabiliser Mounting	280, 300 SL, 300 SL-24, 320, 500, 500 SL, 60 AMG, 600		<b>F8-5217</b>		d=26.5
Stabiliser Mounting	280, 300 SL, 300 SL-24, 320, 500		<b>F8-5222</b>		d=30
Control Arm-/Trailing Arm Bush	280, 300 SL, 300 SL-24, 320, 500, 500 SL, 55 AMG, 60 AMG, 600		<b>F8-5297</b>		H=48; d=14.1; D=40.03
Control Arm-/Trailing Arm Bush	280, 300 SL, 300 SL-24, 320, 500, 500 SL, 60 AMG, 600		<b>F8-5327</b>		d=11; D=36
Belt Pulley, crankshaft	280, 300 SL, 300 SL-24, 320, 500, 500 SL, 55 AMG, 60 AMG, 600, 600 SL	Parameter: 6PK	<b>F8-5663</b>		d=32; D1=160; D2=157; W1=82
Stabiliser Mounting	500, 500 SL		<b>F8-5670</b>		d=13
Stabiliser Mounting	300 SL, 300 SL-24, 600		<b>F8-5671</b>		d=14
Control Arm-/Trailing Arm Bush	280, 300 SL-24, 320, 500, 500 SL, 600		<b>F8-5678</b>		H=58; d=12; D=33
Top Strut Mounting	280, 300 SL, 300 SL-24, 320, 500, 500 SL, 600		<b>F8-5811</b>		
Repair Set, axle beam	280, 300 SL-24, 320, 500, 60 AMG, 600		<b>F8-5820</b>		
Mounting, axle beam	280, 300 SL, 300 SL-24, 320, 500, 500 SL, 600		<b>F8-5821</b>		H=59; d=16; D=66
Mounting, axle beam	280, 300 SL, 300 SL-24, 320, 500, 500 SL, 60 AMG, 600		<b>F8-5874</b>		H=32; d=12; D=66
Rubber Buffer, suspension	280, 300 SL, 300 SL-24, 320, 500, 500 SL, 55 AMG, 60 AMG		<b>F8-5914</b>		H=75
Joint, propshaft	280	; with fastening material;	<b>F8-6239</b>		Bolt Hole Circle Ø [mm]=100; d=46; D=140; W=29.8
Joint, propshaft	280, 300 SL	with fastening material;	<b>F8-6239</b>		Bolt Hole Circle Ø [mm]=100; d=46; D=140; W=29.8
Joint, propshaft	300 SL-24, 320	with fastening material	<b>F8-6239</b>		Bolt Hole Circle Ø [mm]=100; d=46; D=140; W=29.8

<b>F8-5004</b>	<b>F8-5009</b>	<b>F8-5195</b>	<b>F8-5214</b>	<b>F8-5217</b>	<b>F8-5222</b>	<b>F8-5297</b>
Ref.Nr.: 1292400917	Ref.Nr.: 1243300275	Ref.Nr.: 1243300675	Ref.Nr.: 1243234985	Ref.Nr.: 1243235685	Ref.Nr.: 1293230185	Ref.Nr.: 2043520027
<b>F8-5327</b>	<b>F8-5663</b>	<b>F8-5670</b>	<b>F8-5671</b>	<b>F8-5678</b>	<b>F8-5770</b>	<b>F8-5811</b>
Ref.Nr.: 1243523565	Ref.Nr.: 1120350800	Ref.Nr.: 2013261081	Ref.Nr.: 2013261481	Ref.Nr.: 1293520065	Ref.Nr.: 1153200344	Ref.Nr.: 1243200273
<b>F8-5820</b>	<b>F8-5821</b>	<b>F8-5874</b>	<b>F8-5914</b>	<b>F8-6235</b>	<b>F8-6239</b>	<b>F8-6498</b>
Ref.Nr.: 1243508608	Ref.Nr.: 1293511542	Ref.Nr.: 1293510742	Ref.Nr.: 1293230744	Ref.Nr.: 1264100215	Ref.Nr.: 1704100015	Ref.Nr.: 1242400018

Article Description

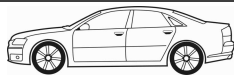

Article Nr.

Fitting Position



<b>SL (R129)</b>			<b>03/1989 → 10/2001</b>		
Mounting, manual transmission	280		<b>F8-6498</b>		
Mounting, manual transmission	300 SL , 300 SL-24 , 320		<b>F8-6498</b>		
Mounting, manual transmission	500	M 119.972	<b>F8-6498</b>		
Mounting, manual transmission	500 SL	M 119.960	<b>F8-6498</b>		
Control Arm-/Trailing Arm Bush	280, 300 SL , 320, 500, 500 SL , 600	ch.F049046→	<b>F8-6804</b>	↓	
Control Arm-/Trailing Arm Bush	280, 300 SL , 320, 500, 500 SL , 600	ch.F049046→	<b>F8-6805</b>	↓	
Engine Mounting	280, 320	Aluminium;	<b>F8-7747</b>		L=104
Engine Mounting	500, 55 AMG	Aluminium	<b>F8-7747</b>		L=104
Control Arm-/Trailing Arm Bush	280, 300 SL , 300 SL-24 , 320, 500, 500 SL , 55 AMG , 60 AMG , 600		<b>G9-503</b>	⊕ ⊕	H=43; d=12; D=31
Control Arm-/Trailing Arm Bush	280, 300 SL , 300 SL-24 , 320, 500, 500 SL , 55 AMG , 60 AMG , 600		<b>G9-651</b>	⊕ ⊕	d=12
Control Arm-/Trailing Arm Bush	280, 300 SL , 300 SL-24 , 320, 500, 500 SL , 55 AMG , 60 AMG , 600		<b>G9-652</b>	⊕ ⊕	d=13
<b>SL (R230)</b>			<b>10/2001 → 01/2012</b>		
Belt Pulley, crankshaft	350, 500, 55 AMG, 55 AMG Kompressor , 600, 65 AMG	Parameter: 6PK	<b>F8-5663</b>		d=32; D1=160; D2=157; W1=82
Control Arm-/Trailing Arm Bush	350, 500, 55 AMG , 55 AMG Kompressor , 600, 65 AMG		<b>F8-6112</b>	⊕ ⊕ ↓	
Mounting, axle beam	350, 500, 55 AMG , 55 AMG Kompressor , 600, 65 AMG		<b>F8-6119</b>		
Mounting, axle beam	350, 500, 55 AMG , 55 AMG Kompressor , 600, 65 AMG	not for	<b>F8-6144</b>	⊕ ⊕	
Control Arm-/Trailing Arm Bush	280, 350, 500, 55 AMG , 55 AMG Kompressor , 600, 65 AMG		<b>F8-6145</b>	⊕ ⊕	d=12.2
Tie Bar Bush	55 AMG, 55 AMG Kompressor , 63AMG, 65 AMG		<b>F8-6161</b>	⊕ ⊕	
Mounting, axle beam	350, 500, 55 AMG , 55 AMG Kompressor , 600, 65 AMG		<b>F8-6182</b>	⊕ ⊕	H=78; d=12; D=51.5
Mounting, axle beam	350, 500, 55 AMG , 55 AMG Kompressor , 600, 65 AMG		<b>F8-6184</b>	⊕ ⊕	
Joint, propshaft	500	with fastening material;  7-speed	<b>F8-6760</b>		d=57.5; D=145; Thick./Strength 1 [mm]=31.5
Control Arm-/Trailing Arm Bush	280, 300, 350, 500		<b>F8-8129</b>	⊕ ⊕	d=12; D=38,5
Control Arm-/Trailing Arm Bush	280, 300, 350, 500		<b>F8-8130</b>	⊕ ⊕	
Engine Mounting	280, 300, 350		<b>F8-8153</b>		
<b>SL Coupe (C107)</b>			<b>01/1972 → 09/1981</b>		
Repair Kit, reversing lever	280 SLC , 350 SLC , 380 SLC , 450 SLC , 450 SLC 5.0		<b>F7-9001</b>	⊕	

<b>F7-9001</b>	<b>F8-4001</b>	<b>F8-5663</b>	<b>F8-6112</b>	<b>F8-6119</b>	<b>F8-6144</b>	<b>F8-6145</b>
Ref.Nr.: 1234600050	Ref.Nr.: 1164102781	Ref.Nr.: 1120350800	Ref.Nr.: 2113332914	Ref.Nr.: 2113510642	Ref.Nr.: 2303511442	Ref.Nr.: 2303521565
<b>F8-6161</b>	<b>F8-6182</b>	<b>F8-6184</b>	<b>F8-6498</b>	<b>F8-6760</b>	<b>F8-6804</b>	<b>F8-6805</b>
Ref.Nr.: 2113520865	Ref.Nr.: 2203521365	Ref.Nr.: 2113511442	Ref.Nr.: 1242400018	Ref.Nr.: 0004110200	Ref.Nr.: 1243334214	Ref.Nr.: 1243334314
<b>F8-7747</b>	<b>F8-8129</b>	<b>F8-8130</b>	<b>F8-8153</b>	<b>G9-503</b>	<b>G9-651</b>	<b>G9-652</b>
Ref.Nr.: 1402401218	Ref.Nr.: 2303521865	Ref.Nr.: A2303521465	Ref.Nr.: 2112403017	Ref.Nr.: 1243524365	Ref.Nr.: 1243529065	Ref.Nr.: 1243528665

**Article Description****Article Nr.****Fitting Position**

<b>SL Coupe (C107)</b>		<b>01/1972 → 09/1981</b>	
Mounting, propshaft	280 SLC, 350 SLC, 380 SLC, 450 SLC 5.0		H=108; d=55; D=95; T [mm]=128
Control Arm-/Trailing Arm Bush	280 SLC, 350 SLC, 380 SLC, 450 SLC 5.0		H=64.5; d=16.4; D1=42; D2=53
Control Arm-/Trailing Arm Bush	280 SLC, 350 SLC, 380 SLC, 450 SLC, 450 SLC 5.0		d=12; D=47; W=28.5
Mounting, axle beam	280 SLC, 350 SLC, 380 SLC, 450 SLC, 450 SLC 5.0		
Repair Set, axle beam	280 SLC, 350 SLC, 380 SLC, 450 SLC, 450 SLC 5.0		d=16; L=65; D=54
Rubber Buffer, suspension	280 SLC, 350 SLC, 380 SLC, 450 SLC, 450 SLC 5.0		H=63
Joint, propshaft	280 SLC, 350 SLC, 380 SLC		Bolt Hole Circle Ø [mm]=90
<b>SLK (R170)</b>		<b>09/1996 → 04/2004</b>	
Suspension Kit	200, 200 Kompressor, 230 Kompressor, 320		
Stabiliser Mounting	200, 200 Kompressor, 230 Kompressor, 320		d=18
Stabiliser Mounting	200, 200 Kompressor, 230 Kompressor		H=38; d=24; D=45
Control Arm-/Trailing Arm Bush	200, 200 Kompressor, 230 Kompressor, 320		H=43; d=20; D=70
Control Arm-/Trailing Arm Bush	200, 200 Kompressor, 230 Kompressor		d=11; D=36
Engine Mounting	200, 200 Kompressor, 230 Kompressor		
Belt Pulley, crankshaft	All Models	Parameter: 6PK	
Control Arm-/Trailing Arm Bush	200, 200 Kompressor, 230 Kompressor		H=58; d=12; D=33
Repair Set, axle beam	200, 200 Kompressor, 230 Kompressor	with fastening material; with accessories	
Control Arm-/Trailing Arm Bush	200, 200 Kompressor, 230 Kompressor		
Repair Set, axle beam	200		
Mounting, axle beam	200		
Stabiliser Mounting	200 Kompressor, 230 Kompressor, 320		
Joint, propshaft	200 Kompressor, 230 Kompressor	with fastening material	
Rubber Buffer, suspension	All Models		
Suspension Kit	All Models	with fastening material	
Control Arm-/Trailing Arm Bush	200 Kompressor, 230 Kompressor, 32 AMG Kompressor, 320		
Control Arm-/Trailing Arm Bush	200, 200 Kompressor, 230 Kompressor	for OE: 20233377 14	
Control Arm-/Trailing Arm Bush	200, 200 Kompressor, 230 Kompressor	for OE: 20233362 14	
Mounting, manual transmission	200, 200 Kompressor, 230 Kompressor		

<b>F8-4001</b>	<b>F8-4005</b>	<b>F8-5197</b>	<b>F8-5214</b>	<b>F8-5236</b>	<b>F8-5307</b>	<b>F8-5327</b>
Ref.Nr.: 1164102781	Ref.Nr.: 1153523265	Ref.Nr.: 1703300075	Ref.Nr.: 1243234985	Ref.Nr.: 1243235485	Ref.Nr.: 2023338714	Ref.Nr.: 1243523565
<b>F8-5460</b>	<b>F8-5663</b>	<b>F8-5678</b>	<b>F8-5688</b>	<b>F8-5697</b>	<b>F8-5698</b>	<b>F8-5720</b>
Ref.Nr.: 2022401717	Ref.Nr.: 1120350800	Ref.Nr.: 1293520065	Ref.Nr.: 1153333014	Ref.Nr.: 1243506708	Ref.Nr.: 2023510842	Ref.Nr.: 1073300275
<b>F8-5730</b>	<b>F8-5770</b>	<b>F8-5820</b>	<b>F8-5821</b>	<b>F8-5973</b>	<b>F8-6235</b>	<b>F8-6239</b>
Ref.Nr.: 1153523665	Ref.Nr.: 1153200344	Ref.Nr.: 1243508608	Ref.Nr.: 1293511542	Ref.Nr.: 1243234485	Ref.Nr.: 1264100215	Ref.Nr.: 1704100015

Article Description

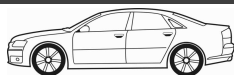

Article Nr.

Fitting Position



<b>SLK (R170)</b>		<b>09/1996 → 04/2004</b>	
Control Arm-/Trailing Arm Bush	All Models	<b>G9-503</b>	H=43; d=12; D=31
Control Arm-/Trailing Arm Bush	All Models	<b>G9-651</b>	d=12
Control Arm-/Trailing Arm Bush	All Models	<b>G9-652</b>	d=13
<b>SLK (R171)</b>		<b>03/2004 → 02/2011</b>	
Dust Cover Kit, shock absorber	200 Kompressor , 280, 350, 55 AMG	<b>AK-735225</b>	
Alternator Freewheel Clutch	200 Kompressor	<b>F5-1056</b>	
Control Arm-/Trailing Arm Bush	200 Kompressor , 350, 55 AMG	<b>F8-5678</b>	H=58; d=12; D=33
Mounting, axle beam	200 Kompressor , 280, 350, 55 AMG	<b>F8-5873</b>	H=29; d=15; D=66
Mounting, axle beam	200 Kompressor , 280, 350	<b>F8-6148</b>	
Joint, propshaft	350 ch.F156166→; with fastening material; 6-speed,  7-speed	<b>F8-7721S</b>	
Mounting, steering gear	200 Kompressor , 280, 300, 350	<b>F8-7932</b>	
Engine Mounting	200 Kompressor	<b>F8-8153</b>	
Control Arm-/Trailing Arm Bush	200 Kompressor , 350, 55 AMG	<b>G9-503</b>	H=43; d=12; D=31
Control Arm-/Trailing Arm Bush	200 Kompressor , 350, 55 AMG	<b>G9-651</b>	d=12
Control Arm-/Trailing Arm Bush	200 Kompressor , 350, 55 AMG	<b>G9-652</b>	d=13
<b>SLK (R172)</b>		<b>02/2011 →</b>	
Mounting, axle beam	200, 250, 250 CDI , 350, 55 AMG	<b>F8-5873</b>	H=29; d=15; D=66
Anti-Friction Bearing	200, 250, 350	<b>F8-7631</b>	
Control Arm-/Trailing Arm Bush	200, 250, 350	<b>F8-7671</b>	
Control Arm-/Trailing Arm Bush	200, 250, 350	<b>F8-7858</b>	H1=80; H2=61; d=15; D=70.2
<b>SPRINTER 2-t Bus (901, 902)</b>		<b>02/1995 → 05/2006</b>	
Dust Cover Kit, shock absorber	All Models	<b>AK-735418</b>	H=200
Alternator Freewheel Clutch	208 D, 210 D, 212 D	<b>F5-1003</b>	
Alternator Freewheel Clutch	208 CDI, 211 CDI, 213 CDI, 216 CDI	<b>F5-1017</b>	
Alternator Freewheel Clutch	208 CDI, 211 CDI, 213 CDI, 216 CDI	<b>F5-1019</b>	
Bush, leaf spring	All Models	<b>F8-5019</b>	H=80; d=12; D1=24; D2=39
Stabiliser Mounting	208 CDI, 210 D, 211 CDI, 212 D, 213 CDI, 214, 214 NGT, 216 CDI	<b>F8-5378</b>	d=25; W=30
Stabiliser Mounting	All Models	<b>F8-5752</b>	H=26; d=12; D=26

<b>AK-735225</b>	<b>AK-735418</b>	<b>F5-1003</b>	<b>F5-1017</b>	<b>F5-1019</b>	<b>F5-1056</b>	<b>F8-5019</b>
Ref.Nr.: 1713230044	Ref.Nr.: 2D0412135	Ref.Nr.: 6041500060	Ref.Nr.: 6111500160	Ref.Nr.: 5117591AA	Ref.Nr.: 2711550016	Ref.Nr.: 2D0511171
<b>F8-5378</b>	<b>F8-5678</b>	<b>F8-5752</b>	<b>F8-5788</b>	<b>F8-5873</b>	<b>F8-6148</b>	<b>F8-7631</b>
Ref.Nr.: 9043230085	Ref.Nr.: 1293520065	Ref.Nr.: 5103955AB	Ref.Nr.: 2D0511171B	Ref.Nr.: 1293512142	Ref.Nr.: 1713510142	Ref.Nr.: 2049810025
<b>F8-7671</b>	<b>F8-7721S</b>	<b>F8-7858</b>	<b>F8-7932</b>	<b>F8-8153</b>	<b>G9-503</b>	<b>G9-651</b>
Ref.Nr.: 2043306811	Ref.Nr.: 2114100415	Ref.Nr.: 2033331014	Ref.Nr.: 2033330514	Ref.Nr.: 2112403017	Ref.Nr.: 1243524365	Ref.Nr.: 1243529065





Article Description



Article Nr.

Fitting Position



<b>SPRINTER 2-t Bus (901, 902)</b>		<b>02/1995 → 05/2006</b>	
Mounting, leaf spring	208 D, 212 D, 214	<b>F8-5788</b>	H=80; d=12.2; D=50
Stabiliser Mounting	All Models	<b>F8-5846</b>	H=39; d=23; D=35
Bush, leaf spring	212 D, 214	<b>F8-5979</b>	d=12; L=134
Stabiliser Mounting	208 CDI, 208 D, 211 CDI, 212 D, 214, 216 CDI	<b>F8-6017</b>	d=22
Mounting, propshaft	All Models	<b>F8-6240</b>	
Control Arm-/Trailing Arm Bush	All Models	<b>F8-6529</b>	
Top Strut Mounting	All Models	<b>F8-6700</b>	
Top Strut Mounting	All Models	<b>F8-6704</b>	
Protective Cap/Bellow, shock absorber	All Models	<b>F8-7160</b>	H=200
Mounting, automatic transmission	All Models	<b>F8-8144</b>	
Engine Mounting	210 D, 212 D, 216 CDI	<b>F8-8147</b>	
<b>SPRINTER 2-t Box (901, 902)</b>		<b>02/1995 → 05/2006</b>	
Dust Cover Kit, shock absorber	All Models	<b>AK-735418</b>	H=200
Alternator Freewheel Clutch	208 D, 210 D, 212 D	<b>F5-1003</b>	
Alternator Freewheel Clutch	208 CDI, 211 CDI, 213 CDI	<b>F5-1017</b>	
Alternator Freewheel Clutch	208 CDI, 211 CDI, 213 CDI, 216 CDI	<b>F5-1019</b>	
Bush, leaf spring	All Models	<b>F8-5019</b>	H=80; d=12; D1=24; D2=39
Bearing Bush, stabiliser	208 D, 210 D, 212 D, 214	<b>F8-5261</b>	d=13,5
Stabiliser Mounting	All Models	<b>F8-5378</b>	d=25; W=30
Stabiliser Mounting	All Models	<b>F8-5752</b>	H=26; d=12; D=26
Mounting, leaf spring	208 D, 212 D, 214	<b>F8-5788</b>	H=80; d=12.2; D=50
Stabiliser Mounting	208 D, 212 D, 214	<b>F8-5846</b>	H=39; d=23; D=35
Bush, leaf spring	208 CDI, 208 D, 210 D, 211 CDI, 212 D, 213 CDI, 214, 216 CDI	<b>F8-5979</b>	d=12; L=134
Stabiliser Mounting	208 CDI, 208 D, 210 D, 211 CDI, 212 D, 213 CDI, 214, 216 CDI	<b>F8-6017</b>	d=22
Mounting, propshaft	208 CDI, 208 D, 210 D, 211 CDI, 212 D, 213 CDI, 214, 214 NGT, 216 CDI	<b>F8-6240</b>	
Control Arm-/Trailing Arm Bush	All Models	<b>F8-6529</b>	
Top Strut Mounting	All Models	<b>F8-6700</b>	
Top Strut Mounting	All Models	<b>F8-6704</b>	
Protective Cap/Bellow, shock absorber	All Models	<b>F8-7160</b>	H=200
Mounting, automatic transmission	All Models	<b>F8-8144</b>	

<b>AK-735418</b>	<b>F5-1003</b>	<b>F5-1017</b>	<b>F5-1019</b>	<b>F8-5019</b>	<b>F8-5261</b>	<b>F8-5378</b>
Ref.Nr.: 2D0412135	Ref.Nr.: 6041500060	Ref.Nr.: 6111500160	Ref.Nr.: 5117591AA	Ref.Nr.: 2D0511171	Ref.Nr.: 2D0411041A	Ref.Nr.: 9043230085
<b>F8-5752</b>	<b>F8-5788</b>	<b>F8-5846</b>	<b>F8-5979</b>	<b>F8-6017</b>	<b>F8-6240</b>	<b>F8-6529</b>
Ref.Nr.: 5103955AB	Ref.Nr.: 2D0511171B	Ref.Nr.: 2D0511413A	Ref.Nr.: 2D0511181	Ref.Nr.: 9013230185	Ref.Nr.: 2D0 598 351	Ref.Nr.: 2D0 407 140
<b>F8-6700</b>	<b>F8-6704</b>	<b>F8-7160</b>	<b>F8-8144</b>	<b>F8-8147</b>		
Ref.Nr.: 2D0407183	Ref.Nr.: 2D0407183A	Ref.Nr.: 2D0412135	Ref.Nr.: 2D0199379B	Ref.Nr.: 2D0199379A		

Article Description



Article Nr.

Fitting Position



<b>SPRINTER 2-t Box (901, 902)</b>		<b>02/1995 → 05/2006</b>	
Engine Mounting	210 D, 211 CDI, 212 D, 213 CDI, 216 CDI	F8-8147	
<b>SPRINTER 2-t Platform/Chassis (901, 902)</b>		<b>01/1995 → 05/2006</b>	
Dust Cover Kit, shock absorber	All Models	AK-735418	⊕ ⊕ ⊕ H=200
Alternator Freewheel Clutch	208 D, 210 D, 212 D	F5-1003	
Alternator Freewheel Clutch	208 CDI, 211 CDI, 213 CDI, 216 CDI	F5-1017	
Alternator Freewheel Clutch	208 CDI, 211 CDI, 213 CDI, 216 CDI	F5-1019	
Bush, leaf spring	All Models	F8-5019	H=80; d=12; D1=24; D2=39
Bearing Bush, stabiliser	208 D, 210 D, 212 D, 214	F8-5261	⊕ ⊕ ⊕ d=13,5
Stabiliser Mounting	208 CDI, 208 D, 210 D, 211 CDI, 212 D, 213 CDI, 214, 214 NGT, 216 CDI	F8-5378	⊕ ⊕ ⊕ d=25; W=30
Stabiliser Mounting	All Models	F8-5752	⊕ ⊕ ⊕ H=26; d=12; D=26
Mounting, leaf spring	208 D, 210 D, 212 D, 214	F8-5788	⊕ ⊕ ⊕ H=80; d=12.2; D=50
Stabiliser Mounting	208 D, 210 D, 212 D, 214	F8-5846	⊕ ⊕ ⊕ H=39; d=23; D=35
Bush, leaf spring	208 CDI, 208 D, 210 D, 211 CDI, 212 D, 213 CDI, 214, 216 CDI	F8-5979	⊕ ⊕ ⊕ ↑ d=12; L=134
Stabiliser Mounting	208 CDI, 208 D, 210 D, 211 CDI, 212 D, 213 CDI, 214, 216 CDI	F8-6017	⊕ ⊕ ⊕ d=22
Mounting, propshaft	208 CDI, 208 D, 210 D, 211 CDI, 212 D, 213 CDI, 214, 214 NGT, 216 CDI	F8-6240	
Control Arm-/Trailing Arm Bush	All Models	F8-6529	⊕ ⊕ ⊕ ↓
Top Strut Mounting	All Models	F8-6700	⊕ ⊕ ⊕ ↑
Top Strut Mounting	All Models	F8-6704	⊕ ⊕ ⊕ ↓
Protective Cap/Bellow, shock absorber	All Models	F8-7160	⊕ ⊕ ⊕ H=200
Mounting, automatic transmission	All Models	F8-8144	
Engine Mounting	210 D, 211 CDI, 212 D, 213 CDI, 216 CDI	F8-8147	
<b>SPRINTER 3-t Bus (903)</b>		<b>02/1995 → 05/2006</b>	
Dust Cover Kit, shock absorber	2.9 TDi, 308 CDI, 308 D, 308 E, 310 D 4x4, 311 CDI, 311 CDI 4x4, 312 D 2.9, 312 D 2.9 4x4, 313 CDI, 313 CDI 4x4, 314, 314 4x4, 314 NGT, 316 CDI, 316 CDI 4x4	AK-735418	⊕ ⊕ ⊕ H=200
Alternator Freewheel Clutch	308 CDI, 308 D, 310 D 4x4, 312 D 2.9, 312 D 2.9 4x4	F5-1003	
Alternator Freewheel Clutch	311 CDI, 311 CDI 4x4, 313 CDI, 313 CDI 4x4, 316 CDI	F5-1017	
Alternator Freewheel Clutch	311 CDI, 311 CDI 4x4, 313 CDI, 313 CDI 4x4, 316 CDI	F5-1019	
Bush, leaf spring	308 CDI, 308 D, 308 E, 310 D 4x4, 311 CDI, 312 D 2.9, 312 D 2.9 4x4, 313 CDI, 314, 314 NGT, 316 CDI	F8-5019	H=80; d=12; D1=24; D2=39
Stabiliser Mounting	310 D 4x4, 311 CDI 4x4, 312 D 2.9 4x4, 313 CDI 4x4, 314 4x4, 316 CDI 4x4	F8-5378	⊕ ⊕ ⊕ d=25; W=30

<b>AK-735418</b>	<b>F5-1003</b>	<b>F5-1017</b>	<b>F5-1019</b>	<b>F8-5019</b>	<b>F8-5261</b>	<b>F8-5378</b>
Ref.Nr.: 2D0412135	Ref.Nr.: 6041500060	Ref.Nr.: 6111500160	Ref.Nr.: 5117591AA	Ref.Nr.: 2D0511171	Ref.Nr.: 2D0411041A	Ref.Nr.: 9043230085
<b>F8-5752</b>	<b>F8-5788</b>	<b>F8-5846</b>	<b>F8-5979</b>	<b>F8-6017</b>	<b>F8-6240</b>	<b>F8-6529</b>
Ref.Nr.: 5103955AB	Ref.Nr.: 2D0511171B	Ref.Nr.: 2D0511413A	Ref.Nr.: 2D0511181	Ref.Nr.: 9013230185	Ref.Nr.: 2D0 598 351	Ref.Nr.: 2D0 407 140
<b>F8-6700</b>	<b>F8-6704</b>	<b>F8-7160</b>	<b>F8-8144</b>	<b>F8-8147</b>		
Ref.Nr.: 2D0407183	Ref.Nr.: 2D0407183A	Ref.Nr.: 2D0412135	Ref.Nr.: 2D0199379B	Ref.Nr.: 2D0199379A		



Article Description



Article Nr.

Fitting Position



<b>SPRINTER 3-t Bus (903)</b>		<b>02/1995 → 05/2006</b>	
Stabiliser Mounting	308 CDI, 308 D, 308 E, 310 D 4x4, 311 CDI, 311 CDI 4x4, 312 D 2.9, 312 D 2.9 4x4, 313 CDI, 313 CDI 4x4, 314, 314 4x4, 314 NGT, 316 CDI, 316 CDI 4x4	<b>F8-5752</b>	⊕ ⊕ H=26; d=12; D=26
Mounting, leaf spring	308 D	<b>F8-5788</b>	⊕ ⊕ H=80; d=12.2; D=50
Stabiliser Mounting	308 D	<b>F8-5846</b>	⊕ ⊕ H=39; d=23; D=35
Bush, leaf spring	311 CDI, 313 CDI, 316 CDI, 316 CDI 4x4	<b>F8-5979</b>	⊕ ⊕ ↑ d=12; L=134
Stabiliser Mounting	308 CDI, 308 D, 310 D 4x4, 311 CDI, 313 CDI, 313 CDI 4x4, 316 CDI, 316 CDI 4x4	<b>F8-6017</b>	⊕ ⊕ d=22
Mounting, propshaft	2.9 TDi, 308 CDI, 308 D, 310 D 4x4, 311 CDI, 311 CDI 4x4, 313 CDI, 313 CDI 4x4, 314, 314 4x4, 314 NGT, 316 CDI, 316 CDI 4x4	<b>F8-6240</b>	
Control Arm-/Trailing Arm Bush	2.9 TDi, 308 CDI, 308 D, 308 E, 310 D 4x4, 311 CDI, 311 CDI 4x4, 312 D 2.9, 312 D 2.9 4x4, 313 CDI, 313 CDI 4x4, 314, 314 4x4, 314 NGT, 316 CDI, 316 CDI 4x4	<b>F8-6529</b>	⊕ ⊕ ↓
Top Strut Mounting	308 CDI, 308 D, 308 E, 310 D 4x4, 311 CDI, 311 CDI 4x4, 312 D 2.9, 312 D 2.9 4x4, 313 CDI, 313 CDI 4x4, 314, 314 4x4, 314 NGT, 316 CDI, 316 CDI 4x4	<b>F8-6700</b>	⊕ ⊕ ↑
Top Strut Mounting	2.9 TDi, 308 CDI, 308 D, 308 E, 310 D 4x4, 311 CDI, 311 CDI 4x4, 312 D 2.9, 312 D 2.9 4x4, 313 CDI, 313 CDI 4x4, 314, 314 4x4, 314 NGT, 316 CDI, 316 CDI 4x4	<b>F8-6704</b>	⊕ ⊕ ↓
Protective Cap/Bellow, shock absorber	2.9 TDi, 308 CDI, 308 D, 308 E, 310 D 4x4, 311 CDI, 311 CDI 4x4, 312 D 2.9, 312 D 2.9 4x4, 313 CDI, 313 CDI 4x4, 314, 314 4x4, 314 NGT, 316 CDI, 316 CDI 4x4	<b>F8-7160</b>	⊕ ⊕ H=200
Mounting, automatic transmission	308 CDI, 308 D, 308 E, 310 D 4x4, 311 CDI, 312 D 2.9, 312 D 2.9 4x4, 313 CDI, 314, 314 NGT, 316 CDI	<b>F8-8144</b>	
Engine Mounting	2.9 TDi, 310 D 4x4, 311 CDI, 311 CDI 4x4, 312 D 2.9, 312 D 2.9 4x4, 313 CDI, 313 CDI 4x4, 316 CDI, 316 CDI 4x4	<b>F8-8147</b>	
<b>SPRINTER 3-t Box (903)</b>		<b>02/1995 → 05/2006</b>	
Dust Cover Kit, shock absorber	All Models	<b>AK-735418</b>	⊕ ⊕ H=200
Alternator Freewheel Clutch	308 D 2.3, 310 D 2.9, 312 D 2.9, 312 D 2.9 4x4	<b>F5-1003</b>	
Alternator Freewheel Clutch	308 CDI, 311 CDI, 311 CDI 4x4, 313 CDI, 313 CDI 4x4, 316 CDI, 316 CDI 4x4	<b>F5-1017</b>	
Alternator Freewheel Clutch	308 CDI, 311 CDI, 311 CDI 4x4, 313 CDI, 313 CDI 4x4, 316 CDI, 316 CDI 4x4	<b>F5-1019</b>	
Bush, leaf spring	308 CDI, 308 D 2.3, 310 D 2.9, 311 CDI, 312 D 2.9, 313 CDI, 314, 314 NGT, 316 CDI	<b>F8-5019</b>	H=80; d=12; D1=24; D2=39
Bearing Bush, stabiliser	308 D 2.3, 310 D 2.9, 312 D 2.9, 314	<b>F8-5261</b>	⊕ ⊕ d=13,5
Stabiliser Mounting	308 CDI, 308 D 2.3, 310 D 2.9, 311 CDI, 311 CDI 4x4, 312 D 2.9, 312 D 2.9 4x4, 313 CDI, 313 CDI 4x4, 314, 314 4x4, 316 CDI 4x4	<b>F8-5378</b>	⊕ ⊕ d=25; W=30

<b>AK-735418</b>	<b>F5-1003</b>	<b>F5-1017</b>	<b>F5-1019</b>	<b>F8-5019</b>	<b>F8-5261</b>	<b>F8-5378</b>
Ref.Nr.: 2D0412135	Ref.Nr.: 6041500060	Ref.Nr.: 6111500160	Ref.Nr.: 5117591AA	Ref.Nr.: 2D0511171	Ref.Nr.: 2D0411041A	Ref.Nr.: 9043230085
<b>F8-5752</b>	<b>F8-5788</b>	<b>F8-5846</b>	<b>F8-5979</b>	<b>F8-6017</b>	<b>F8-6240</b>	<b>F8-6529</b>
Ref.Nr.: 5103955AB	Ref.Nr.: 2D0511171B	Ref.Nr.: 2D0511413A	Ref.Nr.: 2D0511181	Ref.Nr.: 9013230185	Ref.Nr.: 2D0 598 351	Ref.Nr.: 2D0 407 140
<b>F8-6700</b>	<b>F8-6704</b>	<b>F8-7160</b>	<b>F8-8144</b>	<b>F8-8147</b>		
Ref.Nr.: 2D0407183	Ref.Nr.: 2D0407183A	Ref.Nr.: 2D0412135	Ref.Nr.: 2D0199379B	Ref.Nr.: 2D0199379A		

Article Description



Article Nr.

Fitting Position



<b>SPRINTER 3-t Box (903)</b>		<b>02/1995 → 05/2006</b>	
Stabiliser Mounting	All Models	<b>F8-5752</b>	H=26; d=12; D=26
Mounting, leaf spring	308 D 2.3, 310 D 2.9, 312 D 2.9, 314	<b>F8-5788</b>	H=80; d=12.2; D=50
Stabiliser Mounting	308 D 2.3, 310 D 2.9, 312 D 2.9, 314	<b>F8-5846</b>	H=39; d=23; D=35
Bush, leaf spring	308 CDI, 308 D 2.3, 310 D 2.9, 311 CDI, 311 CDI 4x4, 312 D 2.9, 313 CDI, 313 CDI 4x4, 314, 314 4x4, 316 CDI, 316 CDI 4x4	<b>F8-5979</b>	d=12; L=134
Stabiliser Mounting	308 CDI, 308 D 2.3, 310 D 2.9, 311 CDI, 311 CDI 4x4, 312 D 2.9, 313 CDI, 313 CDI 4x4, 314, 316 CDI, 316 CDI 4x4	<b>F8-6017</b>	d=22
Mounting, propshaft	308 CDI, 308 D 2.3, 310 D 2.9, 311 CDI, 311 CDI 4x4, 312 D 2.9, 313 CDI, 313 CDI 4x4, 314, 314 4x4, 314 NGT, 316 CDI, 316 CDI 4x4	<b>F8-6240</b>	
Control Arm-/Trailing Arm Bush	All Models	<b>F8-6529</b>	
Top Strut Mounting	All Models	<b>F8-6700</b>	
Top Strut Mounting	All Models	<b>F8-6704</b>	
Protective Cap/Bellow, shock absorber	All Models	<b>F8-7160</b>	H=200
Mounting, automatic transmission	308 CDI, 308 D 2.3, 310 D 2.9, 311 CDI, 312 D 2.9, 313 CDI, 314, 314 NGT, 316 CDI	<b>F8-8144</b>	
Engine Mounting	310 D 2.9, 311 CDI, 311 CDI 4x4, 312 D 2.9, 312 D 2.9 4x4, 313 CDI, 313 CDI 4x4, 316 CDI, 316 CDI 4x4	<b>F8-8147</b>	
Bellow, steering	308 CDI	with clamps;	<b>LM-10056S</b> d1=14; d2=56; L [mm]=195
<b>SPRINTER 3-t Platform/Chassis (903)</b>		<b>02/1995 → 05/2006</b>	
Dust Cover Kit, shock absorber	308 CDI, 308 D 2.3, 310 D 2.9, 311 CDI, 311 CDI 4x4, 312 D 2.9, 313 CDI, 313 CDI 4x4, 314, 314 4x4, 314 NGT, 316 CDI, 316 CDI 4x4	<b>AK-735418</b>	H=200
Alternator Freewheel Clutch	308 D 2.3, 310 D 2.9, 312 D 2.9	<b>F5-1003</b>	
Alternator Freewheel Clutch	308 CDI, 311 CDI, 311 CDI 4x4, 313 CDI, 313 CDI 4x4, 316 CDI, 316 CDI 4x4	<b>F5-1017</b>	
Alternator Freewheel Clutch	308 CDI, 311 CDI, 311 CDI 4x4, 313 CDI, 313 CDI 4x4, 316 CDI, 316 CDI 4x4	<b>F5-1019</b>	
Bush, leaf spring	308 CDI, 308 D 2.3, 310 D 2.9, 311 CDI, 312 D 2.9, 313 CDI, 314, 314 NGT, 316 CDI	<b>F8-5019</b>	H=80; d=12; D1=24; D2=39
Bearing Bush, stabiliser	308 D 2.3, 310 D 2.9, 312 D 2.9, 314	<b>F8-5261</b>	d=13,5
Stabiliser Mounting	308 CDI, 308 D 2.3, 310 D 2.9, 311 CDI, 311 CDI 4x4, 312 D 2.9, 313 CDI, 313 CDI 4x4, 314, 314 4x4, 316 CDI 4x4	<b>F8-5378</b>	d=25; W=30
Stabiliser Mounting	308 CDI, 308 D 2.3, 310 D 2.9, 311 CDI, 311 CDI 4x4, 312 D 2.9, 313 CDI, 313 CDI 4x4, 314, 314 4x4, 314 NGT, 316 CDI, 316 CDI 4x4	<b>F8-5752</b>	H=26; d=12; D=26
Mounting, leaf spring	308 D 2.3, 310 D 2.9, 312 D 2.9, 314	<b>F8-5788</b>	H=80; d=12.2; D=50
Stabiliser Mounting	308 D 2.3, 310 D 2.9, 312 D 2.9, 314	<b>F8-5846</b>	H=39; d=23; D=35

<b>AK-735418</b>	<b>F5-1003</b>	<b>F5-1017</b>	<b>F5-1019</b>	<b>F8-5019</b>	<b>F8-5261</b>	<b>F8-5378</b>
Ref.Nr.: 2D0412135	Ref.Nr.: 6041500060	Ref.Nr.: 6111500160	Ref.Nr.: 5117591AA	Ref.Nr.: 2D0511171	Ref.Nr.: 2D0411041A	Ref.Nr.: 9043230085
<b>F8-5752</b>	<b>F8-5788</b>	<b>F8-5846</b>	<b>F8-5979</b>	<b>F8-6017</b>	<b>F8-6240</b>	<b>F8-6529</b>
Ref.Nr.: 5103955AB	Ref.Nr.: 2D0511171B	Ref.Nr.: 2D0511413A	Ref.Nr.: 2D0511181	Ref.Nr.: 9013230185	Ref.Nr.: 2D0 598 351	Ref.Nr.: 2D0 407 140
<b>F8-6700</b>	<b>F8-6704</b>	<b>F8-7160</b>	<b>F8-8144</b>	<b>F8-8147</b>	<b>LM-10056S</b>	
Ref.Nr.: 2D0407183	Ref.Nr.: 2D0407183A	Ref.Nr.: 2D0412135	Ref.Nr.: 2D0199379B	Ref.Nr.: 2D0199379A	Ref.Nr.: 9014605500	



Article Description



Article Nr.

Fitting Position



**SPRINTER 3-t Platform/Chassis (903)** 02/1995 → 05/2006

Bush, leaf spring	308 CDI, 308 D 2.3, 310 D 2.9, 311 CDI, 312 D 2.9, 313 CDI, 313 CDI 4x4, 314, 314 4x4, 316 CDI, 316 CDI 4x4		<b>F8-5979</b>		d=12; L=134
Stabiliser Mounting	308 CDI, 308 D 2.3, 310 D 2.9, 311 CDI, 312 D 2.9, 313 CDI, 313 CDI 4x4, 314, 316 CDI, 316 CDI 4x4		<b>F8-6017</b>		d=22
Mounting, propshaft	308 CDI, 308 D 2.3, 310 D 2.9, 311 CDI, 311 CDI 4x4, 312 D 2.9, 313 CDI, 313 CDI 4x4, 314, 314 4x4, 314 NGT, 316 CDI, 316 CDI 4x4		<b>F8-6240</b>		
Control Arm-/Trailing Arm Bush	308 CDI, 308 D 2.3, 310 D 2.9, 311 CDI, 311 CDI 4x4, 312 D 2.9, 313 CDI, 313 CDI 4x4, 314, 314 4x4, 314 NGT, 316 CDI, 316 CDI 4x4		<b>F8-6529</b>		
Top Strut Mounting	308 CDI, 308 D 2.3, 310 D 2.9, 311 CDI, 311 CDI 4x4, 312 D 2.9, 313 CDI, 313 CDI 4x4, 314, 314 4x4, 314 NGT, 316 CDI, 316 CDI 4x4		<b>F8-6700</b>		
Top Strut Mounting	308 CDI, 308 D 2.3, 310 D 2.9, 311 CDI, 311 CDI 4x4, 312 D 2.9, 313 CDI, 313 CDI 4x4, 314, 314 4x4, 314 NGT, 316 CDI, 316 CDI 4x4		<b>F8-6704</b>		
Protective Cap/Bellow, shock absorber	308 CDI, 308 D 2.3, 310 D 2.9, 311 CDI, 311 CDI 4x4, 312 D 2.9, 313 CDI, 313 CDI 4x4, 314, 314 4x4, 314 NGT, 316 CDI, 316 CDI 4x4		<b>F8-7160</b>		H=200
Mounting, automatic transmission	308 CDI, 308 D 2.3, 310 D 2.9, 311 CDI, 312 D 2.9, 313 CDI, 314, 314 NGT, 316 CDI		<b>F8-8144</b>		
Engine Mounting	310 D 2.9, 311 CDI, 311 CDI 4x4, 312 D 2.9, 313 CDI, 313 CDI 4x4, 316 CDI, 316 CDI 4x4		<b>F8-8147</b>		

**SPRINTER 3-t Bus (906)** 06/2006 →

Alternator Freewheel Clutch	210 CDI, 211 CDI, 215 CDI, 224		<b>F5-1019</b>		
Alternator Freewheel Clutch	216, 224		<b>F5-1056</b>		
Control Arm-/Trailing Arm Bush	211 CDI, 224		<b>F8-5684</b>		H=80; d=16
Control Arm-/Trailing Arm Bush	215 CDI	OM 646.990	<b>F8-5684</b>		H=80; d=16
Stabiliser Mounting	211 CDI, 215 CDI, 224		<b>F8-5752</b>		H=26; d=12; D=26
Control Arm-/Trailing Arm Bush	211 CDI, 215 CDI, 224		<b>F8-7161</b>		
Control Arm-/Trailing Arm Bush	211 CDI, 215 CDI, 224		<b>F8-7162</b>		

**SPRINTER 3-t Box (906)** 06/2006 →

Alternator Freewheel Clutch	209 CDI, 210 CDI, 211 CDI, 213 CDI, 215 CDI, 216 CDI, 224		<b>F5-1019</b>		
Alternator Freewheel Clutch	216, 224		<b>F5-1056</b>		
Alternator Freewheel Clutch	218 CDI, 219 CDI		<b>F5-1126</b>		
Control Arm-/Trailing Arm Bush	209 CDI, 211 CDI, 213 CDI, 215 CDI, 218 CDI, 224		<b>F8-5684</b>		H=80; d=16

<b>F5-1019</b>	<b>F5-1056</b>	<b>F5-1126</b>	<b>F8-5684</b>	<b>F8-5752</b>	<b>F8-5979</b>	<b>F8-6017</b>
Ref.Nr.: 5117591AA	Ref.Nr.: 2711550016	Ref.Nr.: 05175811AA	Ref.Nr.: 6113240350	Ref.Nr.: 5103955AB	Ref.Nr.: 2D0511181	Ref.Nr.: 9013230185
<b>F8-6240</b>	<b>F8-6529</b>	<b>F8-6700</b>	<b>F8-6704</b>	<b>F8-7160</b>	<b>F8-7161</b>	<b>F8-7162</b>
Ref.Nr.: 2D0 598 351	Ref.Nr.: 2D0 407 140	Ref.Nr.: 2D0407183	Ref.Nr.: 2D0407183A	Ref.Nr.: 2D0412135	Ref.Nr.: 2E0407523	Ref.Nr.: 2E0407523A
<b>F8-8144</b>	<b>F8-8147</b>					
Ref.Nr.: 2D0199379B	Ref.Nr.: 2D0199379A					

Article Description



Article Nr.

Fitting Position



<b>SPRINTER 3-t Box (906)</b>		<b>06/2006 →</b>	
Stabiliser Mounting	209 CDI , 211 CDI , 213 CDI , 215 CDI , 218 CDI , 224	<b>F8-5752</b>	H=26; d=12; D=26
Control Arm-/Trailing Arm Bush	209 CDI , 211 CDI , 213 CDI , 215 CDI , 218 CDI , 224	<b>F8-7161</b>	
Control Arm-/Trailing Arm Bush	209 CDI , 211 CDI , 213 CDI , 215 CDI , 218 CDI , 224	<b>F8-7162</b>	
<b>SPRINTER 3-t Platform/Chassis (906)</b>		<b>06/2006 →</b>	
Alternator Freewheel Clutch	209 CDI , 210 CDI , 211 CDI , 213 CDI , 215 CDI , 216 CDI	<b>F5-1019</b>	
Alternator Freewheel Clutch	213 CDI , 216 , 224	<b>F5-1056</b>	
Alternator Freewheel Clutch	218 CDI , 219 CDI	<b>F5-1126</b>	
Control Arm-/Trailing Arm Bush	209 CDI , 211 CDI , 213 CDI , 215 CDI , 218 CDI , 224	<b>F8-5684</b>	H=80; d=16
Stabiliser Mounting	209 CDI , 211 CDI , 213 CDI , 215 CDI , 218 CDI , 224	<b>F8-5752</b>	H=26; d=12; D=26
Control Arm-/Trailing Arm Bush	209 CDI , 211 CDI , 213 CDI , 215 CDI , 218 CDI , 224	<b>F8-7161</b>	
Control Arm-/Trailing Arm Bush	209 CDI , 211 CDI , 213 CDI , 215 CDI , 218 CDI , 224	<b>F8-7162</b>	
<b>SPRINTER 3,5-t Bus (906)</b>		<b>06/2006 →</b>	
Alternator Freewheel Clutch	310 CDI , 311 CDI , 311 CDI 4x4 , 315 CDI , 315 CDI 4x4 , 324	<b>F5-1019</b>	
Alternator Freewheel Clutch	313 CDI , 313 CDI 4x4 , 316 , 316 CDI 4x4 , 316 NGT , 318 CDI , 318 CDI 4x4 , 319 CDI , 319 CDI 4x4 , 324	<b>F5-1056</b>	
Alternator Freewheel Clutch	318 CDI , 318 CDI 4x4 , 319 CDI , 319 CDI 4x4	<b>F5-1126</b>	
Control Arm-/Trailing Arm Bush	311 CDI , 315 CDI , 324	<b>F8-5684</b>	H=80; d=16
Stabiliser Mounting	311 CDI , 315 CDI , 324	<b>F8-5752</b>	H=26; d=12; D=26
Control Arm-/Trailing Arm Bush	311 CDI , 311 CDI 4x4 , 315 CDI , 315 CDI 4x4 , 318 CDI 4x4 , 324	<b>F8-7161</b>	
Control Arm-/Trailing Arm Bush	311 CDI , 311 CDI 4x4 , 315 CDI , 315 CDI 4x4 , 318 CDI 4x4 , 324	<b>F8-7162</b>	
Stabiliser Mounting	311 CDI , 315 CDI , 318 CDI , 324	<b>F8-8105</b>	d=20
Stabiliser Mounting	311 CDI , 315 CDI , 318 CDI , 324	<b>F8-8106</b>	d=23
<b>SPRINTER 3,5-t Box (906)</b>		<b>06/2006 →</b>	
Alternator Freewheel Clutch	309 CDI , 310 CDI , 311 CDI , 311 CDI 4x4 , 313 CDI , 315 CDI , 315 CDI 4x4 , 316 CDI , 316 CDI 4x4 , 324	<b>F5-1019</b>	
Alternator Freewheel Clutch	313 CDI , 313 CDI 4x4 , 316 , 316 LGT , 316 NGT , 318 CDI 4x4 , 319 CDI 4x4 , 324	<b>F5-1056</b>	
Alternator Freewheel Clutch	318 CDI , 318 CDI 4x4 , 319 CDI , 319 CDI 4x4	<b>F5-1126</b>	
Control Arm-/Trailing Arm Bush	311 CDI , 313 CDI , 318 CDI , 324	<b>F8-5684</b>	H=80; d=16

<b>F5-1019</b>	<b>F5-1056</b>	<b>F5-1126</b>	<b>F8-5684</b>	<b>F8-5752</b>	<b>F8-7161</b>	<b>F8-7162</b>
Ref.Nr.: 5117591AA	Ref.Nr.: 2711550016	Ref.Nr.: 05175811AA	Ref.Nr.: 6113240350	Ref.Nr.: 5103955AB	Ref.Nr.: 2E0407523	Ref.Nr.: 2E0407523A
<b>F8-8105</b>	<b>F8-8106</b>					
Ref.Nr.: A9063230040	Ref.Nr.: 9063233685					



Article Description



Article Nr.

Fitting Position



<b>SPRINTER 3,5-t Box (906)</b>			<b>06/2006 →</b>		
Control Arm-/Trailing Arm Bush	315 CDI	OM 646.990	<b>F8-5684</b>		H=80; d=16
Stabiliser Mounting	309 CDI , 311 CDI , 315 CDI , 318 CDI , 324		<b>F8-5752</b>		H=26; d=12; D=26
Control Arm-/Trailing Arm Bush	309 CDI , 311 CDI , 311 CDI 4x4 , 313 CDI , 315 CDI , 315 CDI 4x4 , 316 CDI , 316 CDI 4x4 , 318 CDI , 318 CDI 4x4 , 324		<b>F8-7161</b>		
Control Arm-/Trailing Arm Bush	309 CDI , 311 CDI , 311 CDI 4x4 , 313 CDI , 315 CDI , 315 CDI 4x4 , 316 CDI , 316 CDI 4x4 , 318 CDI , 318 CDI 4x4 , 324		<b>F8-7162</b>		
Stabiliser Mounting	309 CDI , 311 CDI , 315 CDI , 318 CDI , 324	for OE: 0AB; with holder	<b>F8-8105</b>		d=20
Stabiliser Mounting	309 CDI , 311 CDI , 315 CDI , 318 CDI , 324	for OE: 0AC; with holder	<b>F8-8106</b>		d=23
<b>SPRINTER 4-t Bus (904)</b>			<b>02/1996 → 05/2006</b>		
Dust Cover Kit, shock absorber	All Models		<b>AK-735418</b>		H=200
Alternator Freewheel Clutch	408 CDI , 411 CDI , 413 CDI , 416 CDI		<b>F5-1017</b>		
Alternator Freewheel Clutch	408 CDI , 411 CDI , 413 CDI , 416 CDI		<b>F5-1019</b>		
Stabiliser Mounting	All Models		<b>F8-5453</b>		
Bush, leaf spring	All Models		<b>F8-5779</b>		H=80; d=16; D=38
Mounting, propshaft	411 CDI , 413 CDI		<b>F8-6240</b>		
Control Arm-/Trailing Arm Bush	All Models		<b>F8-6529</b>		
Top Strut Mounting	All Models		<b>F8-6700</b>		
Top Strut Mounting	All Models		<b>F8-6704</b>		
Protective Cap/Bellow, shock absorber	All Models		<b>F8-7160</b>		H=200
Stabiliser Mounting	All Models		<b>F8-7920</b>		d=33
Mounting, automatic transmission	All Models		<b>F8-8144</b>		
Engine Mounting	408 CDI , 416 CDI		<b>F8-8147</b>		
<b>SPRINTER 3,5-t Platform/Chassis (906)</b>			<b>06/2006 →</b>		
Alternator Freewheel Clutch	309 CDI , 310 CDI , 311 CDI , 311 CDI 4x4 , 313 CDI , 313 CDI 4x4 , 315 CDI , 315 CDI 4x4 , 316 CDI , 316 CDI 4x4 , 324		<b>F5-1019</b>		
Alternator Freewheel Clutch	313 CDI 4x4 , 316 , 316 LGT , 316 NGT , 319 CDI 4x4 , 324		<b>F5-1056</b>		
Alternator Freewheel Clutch	318 CDI , 318 CDI 4x4 , 319 CDI , 319 CDI 4x4		<b>F5-1126</b>		
Control Arm-/Trailing Arm Bush	309 CDI , 311 CDI , 318 CDI , 324		<b>F8-5684</b>		H=80; d=16
Control Arm-/Trailing Arm Bush	315 CDI	OM 646.990	<b>F8-5684</b>		H=80; d=16
Stabiliser Mounting	309 CDI , 311 CDI , 315 CDI , 318 CDI , 324		<b>F8-5752</b>		H=26; d=12; D=26

<b>AK-735418</b>	<b>F5-1017</b>	<b>F5-1019</b>	<b>F5-1056</b>	<b>F5-1126</b>	<b>F8-5453</b>	<b>F8-5684</b>
Ref.Nr.: 2D0412135	Ref.Nr.: 6111500160	Ref.Nr.: 5117591AA	Ref.Nr.: 2711550016	Ref.Nr.: 05175811AA	Ref.Nr.: 2D0511413B	Ref.Nr.: 6113240350
<b>F8-5752</b>	<b>F8-5779</b>	<b>F8-6240</b>	<b>F8-6529</b>	<b>F8-6700</b>	<b>F8-6704</b>	<b>F8-7160</b>
Ref.Nr.: 5103955AB	Ref.Nr.: 0003210250	Ref.Nr.: 2D0 598 351	Ref.Nr.: 2D0 407 140	Ref.Nr.: 2D0407183	Ref.Nr.: 2D0407183A	Ref.Nr.: 2D0412135
<b>F8-7161</b>	<b>F8-7162</b>	<b>F8-7920</b>	<b>F8-8105</b>	<b>F8-8106</b>	<b>F8-8144</b>	<b>F8-8147</b>
Ref.Nr.: 2E0407523	Ref.Nr.: 2E0407523A	Ref.Nr.: 9043261081	Ref.Nr.: A9063230040	Ref.Nr.: 9063233685	Ref.Nr.: 2D0199379B	Ref.Nr.: 2D0199379A

Article Description

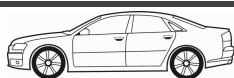

Article Nr.

Fitting Position



<b>SPRINTER 3,5-t Platform/Chassis (906)</b>			<b>06/2006 →</b>		
Control Arm-/Trailing Arm Bush	309 CDI , 311 CDI , 311 CDI 4x4 , 313 CDI , 315 CDI , 315 CDI 4x4 , 316 CDI , 316 CDI 4x4 , 318 CDI , 318 CDI 4x4 , 324		<b>F8-7161</b>		
Control Arm-/Trailing Arm Bush	309 CDI , 311 CDI , 311 CDI 4x4 , 313 CDI , 315 CDI , 315 CDI 4x4 , 316 CDI , 316 CDI 4x4 , 318 CDI , 318 CDI 4x4 , 324		<b>F8-7162</b>		
Stabiliser Mounting	309 CDI , 311 CDI , 315 CDI , 318 CDI , 324	for OE: 0AB; with holder	<b>F8-8105</b>		d=20
Stabiliser Mounting	309 CDI , 311 CDI , 315 CDI , 318 CDI , 324	for OE: 0AC; with holder	<b>F8-8106</b>		d=23
<b>SPRINTER 4-t Box (904)</b>			<b>02/1996 → 05/2006</b>		
Dust Cover Kit, shock absorber	All Models		<b>AK-735418</b>		H=200
Alternator Freewheel Clutch	408 D, 410 D 4x4, 412 D, 412 D 4x4		<b>F5-1003</b>		
Alternator Freewheel Clutch	408 CDI, 411 CDI, 411 CDI 4x4, 413 CDI, 413 CDI 4x4, 416 CDI, 416 CDI 4x4		<b>F5-1017</b>		
Alternator Freewheel Clutch	408 CDI, 411 CDI, 411 CDI 4x4, 413 CDI, 413 CDI 4x4, 416 CDI, 416 CDI 4x4		<b>F5-1019</b>		
Stabiliser Mounting	408 CDI, 411 CDI, 412 D, 413 CDI, 414, 416 CDI		<b>F8-5378</b>		d=25; W=30
Stabiliser Mounting	All Models		<b>F8-5453</b>		
Control Arm-/Trailing Arm Bush	408 CDI, 408 D, 410 D, 410 D 4x4, 411 CDI, 411 CDI 4x4, 412 D, 412 D 4x4, 413 CDI, 413 CDI 4x4, 414, 414 4x4		<b>F8-5684</b>		H=80; d=16
Bush, leaf spring	All Models		<b>F8-5779</b>		H=80; d=16; D=38
Mounting, propshaft	All Models		<b>F8-6240</b>		
Control Arm-/Trailing Arm Bush	All Models		<b>F8-6529</b>		
Top Strut Mounting	All Models		<b>F8-6700</b>		
Top Strut Mounting	All Models		<b>F8-6704</b>		
Protective Cap/Bellow, shock absorber	All Models		<b>F8-7160</b>		H=200
Stabiliser Mounting	All Models		<b>F8-7920</b>		d=33
Mounting, automatic transmission	All Models		<b>F8-8144</b>		
Engine Mounting	410 D, 410 D 4x4, 412 D, 412 D 4x4, 416 CDI, 416 CDI 4x4		<b>F8-8147</b>		
<b>SPRINTER 4-t Platform/Chassis (904)</b>			<b>02/1996 → 05/2006</b>		
Dust Cover Kit, shock absorber	All Models		<b>AK-735418</b>		H=200
Alternator Freewheel Clutch	408 D, 410 D, 410 D 4x4, 412 D, 412 D 4x4		<b>F5-1003</b>		
Alternator Freewheel Clutch	408 CDI, 411 CDI, 411 CDI 4x4, 413 CDI, 413 CDI 4x4, 416 CDI, 416 CDI 4x4		<b>F5-1017</b>		
Alternator Freewheel Clutch	408 CDI, 411 CDI, 411 CDI 4x4, 413 CDI, 413 CDI 4x4, 416 CDI, 416 CDI 4x4		<b>F5-1019</b>		

<b>AK-735418</b>	<b>F5-1003</b>	<b>F5-1017</b>	<b>F5-1019</b>	<b>F8-5378</b>	<b>F8-5453</b>	<b>F8-5684</b>
Ref.Nr.: 2D0412135	Ref.Nr.: 6041500060	Ref.Nr.: 6111500160	Ref.Nr.: 5117591AA	Ref.Nr.: 9043230085	Ref.Nr.: 2D0511413B	Ref.Nr.: 6113240350
<b>F8-5779</b>	<b>F8-6240</b>	<b>F8-6529</b>	<b>F8-6700</b>	<b>F8-6704</b>	<b>F8-7160</b>	<b>F8-7161</b>
Ref.Nr.: 0003210250	Ref.Nr.: 2D0 598 351	Ref.Nr.: 2D0 407 140	Ref.Nr.: 2D0407183	Ref.Nr.: 2D0407183A	Ref.Nr.: 2D0412135	Ref.Nr.: 2E0407523
<b>F8-7162</b>	<b>F8-7920</b>	<b>F8-8105</b>	<b>F8-8106</b>	<b>F8-8144</b>	<b>F8-8147</b>	
Ref.Nr.: 2E0407523A	Ref.Nr.: 9043261081	Ref.Nr.: A9063230040	Ref.Nr.: 9063233685	Ref.Nr.: 2D0199379B	Ref.Nr.: 2D0199379A	





Article Description



Article Nr.

Fitting Position



<b>SPRINTER 4-t Platform/Chassis (904)</b>			<b>02/1996 → 05/2006</b>		
Stabiliser Mounting	408 CDI, 410 D, 411 CDI, 411 CDI 4x4, 412 D, 412 D 4x4, 413 CDI, 413 CDI 4x4, 414, 416 CDI		<b>F8-5378</b>		d=25; W=30
Stabiliser Mounting	All Models		<b>F8-5453</b>		
Control Arm-/Trailing Arm Bush	408 CDI, 408 D, 410 D, 410 D 4x4, 411 CDI, 411 CDI 4x4, 412 D, 412 D 4x4, 413 CDI, 413 CDI 4x4, 414		<b>F8-5684</b>		H=80; d=16
Control Arm-/Trailing Arm Bush	414 4x4	M 111.984	<b>F8-5684</b>		H=80; d=16
Bush, leaf spring	All Models		<b>F8-5779</b>		H=80; d=16; D=38
Bush, leaf spring	411 CDI, 414		<b>F8-5979</b>		d=12; L=134
Mounting, propshaft	All Models		<b>F8-6240</b>		
Control Arm-/Trailing Arm Bush	All Models		<b>F8-6529</b>		
Top Strut Mounting	All Models		<b>F8-6700</b>		
Top Strut Mounting	All Models		<b>F8-6704</b>		
Protective Cap/Bellow, shock absorber	All Models		<b>F8-7160</b>		H=200
Stabiliser Mounting	All Models		<b>F8-7920</b>		d=33
Mounting, automatic transmission	All Models		<b>F8-8144</b>		
Engine Mounting	410 D, 410 D 4x4, 411 CDI, 411 CDI 4x4, 412 D, 412 D 4x4, 413 CDI, 413 CDI 4x4, 416 CDI, 416 CDI 4x4		<b>F8-8147</b>		
<b>SPRINTER 4,6-t Box (906)</b>			<b>06/2006 →</b>		
Alternator Freewheel Clutch	416 CDI		<b>F5-1019</b>		
Alternator Freewheel Clutch	413 CDI		<b>F5-1056</b>		
Alternator Freewheel Clutch	419 CDI		<b>F5-1126</b>		
<b>SPRINTER 4,6-t Platform/Chassis (906)</b>			<b>06/2006 →</b>		
Alternator Freewheel Clutch	416 CDI		<b>F5-1019</b>		
Alternator Freewheel Clutch	413 CDI, 415 CDI, 418 CDI		<b>F5-1056</b>		
Alternator Freewheel Clutch	413 CDI, 418 CDI, 419 CDI		<b>F5-1126</b>		
<b>SPRINTER 5-t Box (906)</b>			<b>06/2006 →</b>		
Alternator Freewheel Clutch	509 CDI, 510 CDI, 511 CDI, 513 CDI, 515 CDI, 516 CDI, 524		<b>F5-1019</b>		
Alternator Freewheel Clutch	524		<b>F5-1056</b>		
Alternator Freewheel Clutch	518 CDI, 518 CDI 4x4, 519 CDI, 519 CDI 4x4		<b>F5-1126</b>		
Control Arm-/Trailing Arm Bush	509 CDI, 511 CDI, 518 CDI		<b>F8-5684</b>		H=80; d=16
Control Arm-/Trailing Arm Bush	515 CDI	OM 646.990	<b>F8-5684</b>		H=80; d=16
Stabiliser Mounting	509 CDI, 511 CDI, 515 CDI, 518 CDI		<b>F8-5752</b>		H=26; d=12; D=26

<b>F5-1019</b>	<b>F5-1056</b>	<b>F5-1126</b>	<b>F8-5378</b>	<b>F8-5453</b>	<b>F8-5684</b>	<b>F8-5752</b>
Ref.Nr.: 5117591AA	Ref.Nr.: 2711550016	Ref.Nr.: 05175811AA	Ref.Nr.: 9043230085	Ref.Nr.: 2D0511413B	Ref.Nr.: 6113240350	Ref.Nr.: 5103955AB
<b>F8-5779</b>	<b>F8-5979</b>	<b>F8-6240</b>	<b>F8-6529</b>	<b>F8-6700</b>	<b>F8-6704</b>	<b>F8-7160</b>
Ref.Nr.: 0003210250	Ref.Nr.: 2D0511181	Ref.Nr.: 2D0 598 351	Ref.Nr.: 2D0 407 140	Ref.Nr.: 2D0407183	Ref.Nr.: 2D0407183A	Ref.Nr.: 2D0412135
<b>F8-7161</b>	<b>F8-7920</b>	<b>F8-8144</b>	<b>F8-8147</b>			
Ref.Nr.: 2E0407523	Ref.Nr.: 9043261081	Ref.Nr.: 2D0199379B	Ref.Nr.: 2D0199379A			

Article Description			Article Nr.	Fitting Position	
---------------------	--	--	-------------	------------------	--

<b>SPRINTER 5-t Box (906)</b>			<b>06/2006 →</b>		
Control Arm-/Trailing Arm Bush	509 CDI , 511 CDI , 515 CDI , 518 CDI , 524		<b>F8-7161</b>		
Control Arm-/Trailing Arm Bush	509 CDI , 511 CDI , 515 CDI , 518 CDI , 524		<b>F8-7162</b>		
Stabiliser Mounting	509 CDI , 511 CDI , 515 CDI , 518 CDI	for OE: 0AB; with holder	<b>F8-8105</b>		d=20
Stabiliser Mounting	509 CDI , 511 CDI , 515 CDI , 518 CDI	for OE: 0AC; with holder	<b>F8-8106</b>		d=23
<b>SPRINTER 5-t Platform/Chassis (905)</b>			<b>04/2001 → 05/2006</b>		
Alternator Freewheel Clutch	All Models		<b>F5-1019</b>		
Engine Mounting	All Models		<b>F8-8147</b>		
<b>SPRINTER 5-t Platform/Chassis (906)</b>			<b>06/2006 →</b>		
Alternator Freewheel Clutch	509 CDI , 510 CDI , 511 CDI , 513 CDI , 515 CDI , 516 CDI , 524		<b>F5-1019</b>		
Alternator Freewheel Clutch	513 CDI 4x4 , 516 , 516 CDI 4x4 , 516 NGT , 524		<b>F5-1056</b>		
Alternator Freewheel Clutch	518 CDI , 518 CDI 4x4 , 519 CDI , 519 CDI 4x4		<b>F5-1126</b>		
Control Arm-/Trailing Arm Bush	509 CDI , 511 CDI , 518 CDI		<b>F8-5684</b>		H=80; d=16
Control Arm-/Trailing Arm Bush	515 CDI	OM 646.990	<b>F8-5684</b>		H=80; d=16
Stabiliser Mounting	509 CDI , 511 CDI , 515 CDI , 518 CDI		<b>F8-5752</b>		H=26; d=12; D=26
Control Arm-/Trailing Arm Bush	509 CDI , 511 CDI , 515 CDI , 518 CDI , 524		<b>F8-7161</b>		
Control Arm-/Trailing Arm Bush	509 CDI , 511 CDI , 515 CDI , 518 CDI , 524		<b>F8-7162</b>		
Stabiliser Mounting	509 CDI , 511 CDI , 515 CDI , 518 CDI	for OE: 0AB; with holder	<b>F8-8105</b>		d=20
Stabiliser Mounting	509 CDI , 511 CDI , 515 CDI , 518 CDI	for OE: 0AC; with holder	<b>F8-8106</b>		d=23
<b>SPRINTER Dumptruck (905)</b>			<b>04/2001 →</b>		
Alternator Freewheel Clutch	All Models		<b>F5-1019</b>		
<b>Saloon (W123)</b>			<b>01/1976 → 12/1985</b>		
Dust Cover Kit, shock absorber	All Models	Universal	<b>AK-735146</b>		
Repair Kit, reversing lever	200, 200 D , 220 D , 230, 230 E , 240 D , 250, 280, 280 E, 300 D		<b>F7-9001</b>		
Mounting, propshaft	200, 200 D , 220 D , 230, 230 E , 240 D , 250, 280, 280 E, 300 D		<b>F8-4001</b>		H=108; d=55; D=95; T [mm]=128
Control Arm-/Trailing Arm Bush	200, 200 D , 220 D , 230, 230 E , 240 D , 250, 280, 280 E, 300 D		<b>F8-4005</b>		H=64.5; d=16.4; D1=42; D2=53
Suspension Kit	200, 200 D , 220 D , 230, 230 E , 240 D , 250, 280, 280 E, 300 D		<b>F8-5020</b>		
Stabiliser Mounting	200, 200 D , 220 D , 230 E , 240 D , 250, 280, 300 D		<b>F8-5137</b>		H=50; d=21; W=74
Stabiliser Mounting	230	ch.→075123	<b>F8-5137</b>		H=50; d=21; W=74

<b>AK-735146</b>	<b>F5-1019</b>	<b>F5-1056</b>	<b>F5-1126</b>	<b>F7-9001</b>	<b>F8-4001</b>	<b>F8-4005</b>
Ref.Nr.:	Ref.Nr.: 5117591AA	Ref.Nr.: 2711550016	Ref.Nr.: 05175811AA	Ref.Nr.: 1234600050	Ref.Nr.: 1164102781	Ref.Nr.: 1153523265
<b>F8-5020</b>	<b>F8-5137</b>	<b>F8-5178</b>	<b>F8-5684</b>	<b>F8-5752</b>	<b>F8-7161</b>	<b>F8-7162</b>
Ref.Nr.: 1165860133	Ref.Nr.: 1233230585	Ref.Nr.: 1233301375	Ref.Nr.: 6113240350	Ref.Nr.: 5103955AB	Ref.Nr.: 2E0407523	Ref.Nr.: 2E0407523A
<b>F8-8105</b>	<b>F8-8106</b>	<b>F8-8147</b>				
Ref.Nr.: A9063230040	Ref.Nr.: 9063233685	Ref.Nr.: 2D0199379A				

**Article Description****Article Nr.****Fitting Position**

<b>Saloon (W123)</b>			<b>01/1976 → 12/1985</b>		
Suspension Kit	200, 200 D , 220 D , 230, 230 E , 250		<b>F8-5178</b>		
Suspension Kit	240 D	ch.306442→	<b>F8-5178</b>		
Suspension Kit	280 E	ch.→099922	<b>F8-5178</b>		
Suspension Kit	300 D	ch.267578→	<b>F8-5178</b>		
Suspension Kit	230 E	ch.082226→	<b>F8-5256</b>		
Suspension Kit	240 D	ch.306443→	<b>F8-5256</b>		
Suspension Kit	250	ch.110246→	<b>F8-5256</b>		
Suspension Kit	280 E	ch.099923→	<b>F8-5256</b>		
Suspension Kit	300 D	ch.267579→	<b>F8-5256</b>		
Stabiliser Mounting	200, 200 D , 220 D , 230, 230 E , 240 D , 250, 280, 280 E , 300 D		<b>F8-5670</b>		d=13
Repair Set, axle beam	200, 200 D , 220 D , 230, 230 E , 240 D , 250, 280, 280 E , 300 D , 300 Turbo-D		<b>F8-5730</b>		d=16; L=65; D=54
Repair Set, axle beam	200	ch.→125651	<b>F8-5731</b>		
Repair Set, axle beam	200 D , 220 D , 250, 280, 280 E		<b>F8-5731</b>		
Repair Set, axle beam	230	ch.→157706	<b>F8-5731</b>		
Repair Set, axle beam	240 D	ch.→050107	<b>F8-5731</b>		
Mounting, axle beam	200, 200 D , 220 D , 230, 230 E , 240 D , 250, 280, 280 E , 300 D		<b>F8-5732</b>		H=65; d=16; D=85
Repair Set, axle beam	200	ch.125652→	<b>F8-5739</b>		
Repair Set, axle beam	200, 230 E , 300 D		<b>F8-5739</b>		
Repair Set, axle beam	230	ch.157707→	<b>F8-5739</b>		
Repair Set, axle beam	240 D	ch.050108→	<b>F8-5739</b>		
Rubber Buffer, suspension	All Models		<b>F8-5770</b>		H=63
Joint, propshaft	240 D , 250, 280, 280 E , 300 D		<b>F8-6235</b>		Bolt Hole Circle Ø [mm]=90
Mounting, manual transmission	250		<b>F8-6498</b>		
Mounting, manual transmission	250, 280 E	ch.A201389, F086256→	<b>F8-6498</b>		
Mounting, manual transmission	280 E	5-speed; Type: 123.033	<b>F8-6498</b>		
Engine Mounting	200	M 115.938;	<b>F8-8194</b>		
Engine Mounting	200	M 115.939;	<b>F8-8194</b>		
Engine Mounting	200 D	ch.226855→	<b>F8-8194</b>		
Engine Mounting	200, 230 E		<b>F8-8194</b>		
Engine Mounting	240 D	ch.207385→	<b>F8-8194</b>		
Control Arm-/Trailing Arm Bush	All Models		<b>G9-514</b>		H=33; d=12; D1=43; D2=51
Control Arm-/Trailing Arm Bush	200, 200 D , 220 D , 230, 230 E , 240 D , 250, 280, 280 E , 300 D		<b>G9-588</b>		H=30; d=16; D=41

<b>F8-5178</b>	<b>F8-5256</b>	<b>F8-5670</b>	<b>F8-5730</b>	<b>F8-5731</b>	<b>F8-5732</b>	<b>F8-5739</b>
Ref.Nr.: 1233301375	Ref.Nr.: 1263300075	Ref.Nr.: 2013261081	Ref.Nr.: 1153523665	Ref.Nr.: 1233500075	Ref.Nr.: 1233511042	Ref.Nr.: 1233500175
<b>F8-5770</b>	<b>F8-6235</b>	<b>F8-6498</b>	<b>F8-8194</b>	<b>G9-514</b>	<b>G9-588</b>	<b>G9-651</b>
Ref.Nr.: 1153200344	Ref.Nr.: 1264100215	Ref.Nr.: 1242400018	Ref.Nr.: 1232414113	Ref.Nr.: 1163336314	Ref.Nr.: 1163334014	Ref.Nr.: 1243529065

Article Description



Article Nr.

Fitting Position



<b>Saloon (W123)</b>				<b>01/1976 → 12/1985</b>	
Control Arm-/Trailing Arm Bush	200			<b>G9-651</b>	⊕ ⊕ ⊕ d=12
Control Arm-/Trailing Arm Bush	200			<b>G9-652</b>	⊕ ⊕ ⊕ d=13
<b>Saloon (W124)</b>				<b>12/1984 → 06/1993</b>	
Dust Cover Kit, shock absorber	200, 200 D, 200 E, 220 E, 230 E, 250 D, 250 Turbo-D, 260 E, 280 E, 300 D, 300 E, 300 E-24, 300 Turbo-D, 300 Turbo-D 4-matic, 400 E 4.2, 500 E			<b>AK-735019</b>	⊕ ⊕ ⊕
Engine Mounting	200 D	09/1989 →; ;		<b>F7-2003</b>	⊕ ⊕
Engine Mounting	200, 200 E, 230 E			<b>F7-2003</b>	⊕ ⊕
Engine Mounting	250 D	;		<b>F7-2003</b>	⊕ ⊕
Repair Kit, reversing lever	200, 200 D, 200 E, 220 E, 230 E, 250 D, 250 Turbo-D, 260 E, 260 E 4-matic, 280 E, 300 D, 300 D 4-matic, 300 E, 300 E 4-matic, 300 E-24, 300 Turbo-D, 300 Turbo-D 4-matic, 400 E 4.2			<b>F7-9001</b>	⊕
Engine Mounting	250 Turbo-D	09/1989 →; ;		<b>F8-2005</b>	⊕ ⊕ ⊕
Engine Mounting	260 E, 300 E			<b>F8-2005</b>	⊕ ⊕ ⊕
Engine Mounting	300 D	09/1989 →;		<b>F8-2005</b>	⊕ ⊕ ⊕
Engine Mounting	300 Turbo-D	09/1989 →;		<b>F8-2005</b>	⊕ ⊕ ⊕
Mounting, propshaft	200, 200 D, 200 E, 230 E, 250 D, 260 E			<b>F8-4002</b>	H=89; d=43; D=83; T [mm]=119
Mounting, propshaft	200, 200 D, 200 E, 230 E, 250 D, 260 E			<b>F8-4003</b>	H=100; d=50; D=93; T [mm]=119
Engine Mounting	400 E 4.2			<b>F8-5004</b>	⊕ ⊕ ⊕ H=105; d=8; D=118; T [mm]=149
Engine Mounting	200 E, 230 E			<b>F8-5005</b>	H=111; D1=90; D2=103
Engine Mounting	250 D	;		<b>F8-5005</b>	H=111; D1=90; D2=103
Engine Mounting	250 Turbo-D, 300 E	; ;		<b>F8-5005</b>	H=111; D1=90; D2=103
Engine Mounting	260 E	;		<b>F8-5005</b>	H=111; D1=90; D2=103
Suspension Kit	200, 200 D, 200 E, 230 E, 250 Turbo-D, 260 E, 300 D, 300 E-24, 300 Turbo-D	ch.→B711095;		<b>F8-5009</b>	⊕ ⊕ ⊕
Suspension Kit	250 D	ch.→B711095, F204091;		<b>F8-5009</b>	⊕ ⊕ ⊕
Suspension Kit	300 E			<b>F8-5009</b>	⊕ ⊕ ⊕
Suspension Kit	300 E	ch.→B711095		<b>F8-5009</b>	⊕ ⊕ ⊕
Control Arm-/Trailing Arm Bush	200, 200 D, 200 E, 220 E, 230 E, 250 D, 250 Turbo-D, 260 E, 280 E, 300 D, 300 E, 300 E-24, 300 Turbo-D, 400 E 4.2			<b>F8-5010</b>	⊕ ⊕ ⊕ ⊕ H=49; d=16; D1=49; D2=65
Suspension Kit	200, 200 D, 200 E, 250 D, 260 E, 300 D, 300 E			<b>F8-5011</b>	⊕ ⊕ ⊕
Joint, propshaft	200, 200 E, 250 D	with add-on material		<b>F8-5015</b>	d=34; D=128
Joint, propshaft	200, 200 E, 250 D	Joint Type: Hard Version; with fastening material		<b>F8-5016</b>	H=26; d=40; Mounting points diam.[mm]=10.2; D=116

<b>AK-735019</b>	<b>F7-2003</b>	<b>F7-9001</b>	<b>F8-2005</b>	<b>F8-4002</b>	<b>F8-4003</b>	<b>F8-5004</b>
Ref.Nr.: 1293230192	Ref.Nr.: 1242400217	Ref.Nr.: 1234600050	Ref.Nr.: 1242401917	Ref.Nr.: 1244100181	Ref.Nr.: 1244100281	Ref.Nr.: 1292400917
<b>F8-5005</b>	<b>F8-5009</b>	<b>F8-5010</b>	<b>F8-5011</b>	<b>F8-5015</b>	<b>F8-5016</b>	<b>F8-5018</b>
Ref.Nr.: 1242400317	Ref.Nr.: 1243300275	Ref.Nr.: 2013335114	Ref.Nr.: 2013300075	Ref.Nr.: 1244100015	Ref.Nr.: 2014102115	Ref.Nr.: 2013512742
<b>G9-651</b>	<b>G9-652</b>					
Ref.Nr.: 1243529065	Ref.Nr.: 1243528665					



Article Description



Article Nr.

Fitting Position



Saloon (W124)		12/1984 → 06/1993			
Mounting, axle beam	200, 200 D, 200 E, 220 E, 230 E, 250 D, 250 Turbo-D, 300 D, 300 D 4-matic, 300 Turbo-D, 300 Turbo-D 4-matic		F8-5018		H=58; D1=68; D2=81
Repair Kit, link	200, 200 D, 200 E, 230 E, 250 D, 250 Turbo-D, 260 E, 300 AMG, 300 D, 300 E, 300 E-24, 300 Turbo-D	ch.→B711095;	F8-5185		
Suspension Kit	200 D, 200 E, 250 D, 250 Turbo-D, 300 D, 300 E, 300 E-24, 300 Turbo-D	ch.B711096→; 09/1989 →;	F8-5195		
Suspension Kit	200 E, 220 E, 280 E, 300 E	ch.B711096→;	F8-5195		
Suspension Kit	320 E	ch.B711096, C018228→; ,	F8-5195		
Suspension Kit	400 E 4.2	ch.B711096→	F8-5195		
Stabiliser Mounting	230 E, 260 E, 400 E 4.2		F8-5209		H=36; d=22.5; D=38
Stabiliser Mounting	200 E, 220 E, 250 D, 250 Turbo-D, 260 E, 280 E, 300 D, 300 E, 300 E-24, 300 Turbo-D, 320 E		F8-5214		d=18
Stabiliser Mounting	200, 200 E, 230 E	ch.A204767→	F8-5214		d=18
Stabiliser Mounting	230 E	ch.F042994→	F8-5216		d=28.5
Stabiliser Mounting	260 E		F8-5216		d=28.5
Stabiliser Mounting	200 D, 230 E	10/1992 →	F8-5217		d=26.5
Stabiliser Mounting	200 E, 220 E, 250 D, 250 Turbo-D, 260 E, 280 E, 300 D, 300 E, 300 E-24, 300 Turbo-D, 320 E, 400 E 4.2		F8-5217		d=26.5
Stabiliser Mounting	200, 200 D, 200 E, 220 E, 230 E, 250 D, 260 E		F8-5218		d=23
Stabiliser Mounting	200, 200 D, 200 E, 230 E		F8-5219		d=24
Stabiliser Mounting	200 D, 200 E, 220 E		F8-5236		H=38; d=24; D=45
Control Arm-/Trailing Arm Bush	200, 200 D, 200 E, 220 E, 230 E, 250 D, 250 Turbo-D, 260 E, 260 E 4-matic, 280 E, 300 D, 300 D 4-matic, 300 E, 300 E 4-matic, 300 E-24, 300 Turbo-D, 300 Turbo-D 4-matic, 320 E, 400 E 4.2, 500 E		F8-5297		H=48; d=14.1; D=40.03
Control Arm-/Trailing Arm Bush	200, 200 D, 200 E, 220 E, 230 E, 250 D, 250 Turbo-D, 260 E, 260 E 4-matic, 280 E, 300 D, 300 D 4-matic, 300 E, 300 E 4-matic, 300 E-24, 300 Turbo-D, 300 Turbo-D 4-matic, 320 E, 400 E 4.2		F8-5327		d=11; D=36
Mounting, axle beam	200, 200 D, 200 E, 220 E, 250 D, 250 Turbo-D, 300 D		F8-5420		d=16; D=51; Thick. [mm]=58
Engine Mounting	250 D		F8-5449		
Engine Mounting	250 Turbo-D	09/1989 →;	F8-5449		
Engine Mounting	260 E, 260 E 4-matic, 300 E		F8-5449		
Engine Mounting	300 D	09/1989 →;	F8-5449		
Engine Mounting	300 D		F8-5449		
Engine Mounting	300 D, 300 Turbo-D		F8-5449		



Article Description



Article Nr.

Fitting Position



Saloon (W124)		12/1984 → 06/1993	
Top Strut Mounting	200, 200 D, 200 E, 220 E, 230 E, 250 D, 250 Turbo-D, 260 E, 280 E, 300 D, 300 E, 300 E-24, 300 Turbo-D, 300 Turbo-D 4-matic, 320 E, 400 E 4.2, 500 E	F8-5502	d=14.5; D=59; Thick. [mm]=130
Stabiliser Mounting	200, 200 D, 200 E, 230 E, 250 D, 250 Turbo-D, 300 D	F8-5670	d=13
Control Arm-/Trailing Arm Bush	200, 200 D, 200 E, 220 E, 230 E, 250 D, 250 Turbo-D, 260 E, 260 E 4-matic, 280 E, 300 D, 300 D 4-matic, 300 E, 300 E 4-matic, 300 E-24, 300 Turbo-D, 300 Turbo-D 4-matic, 320 E, 400 E 4.2, 500 E	F8-5678	H=58; d=12; D=33
Mounting, axle beam	200, 200 D, 200 E, 230 E, 250 D, 250 Turbo-D, 260 E, 260 E 4-matic, 300 D, 300 D 4-matic, 300 E, 300 E 4-matic, 300 E-24, 300 Turbo-D, 300 Turbo-D 4-matic	F8-5733	H=30; d=14; D=47
Mounting, axle beam	200, 200 D, 200 E, 220 E, 230 E, 250 D, 250 Turbo-D, 260 E, 260 E 4-matic, 280 E, 300 D, 300 D 4-matic, 300 E, 300 E 4-matic, 300 E-24, 300 Turbo-D, 300 Turbo-D 4-matic, 320 E, 400 E 4.2, 500 E	F8-5744	
Mounting, axle beam	200, 200 D, 200 E, 230 E, 250 D, 250 Turbo-D, 260 E, 260 E 4-matic, 300 D, 300 D 4-matic, 300 E, 300 E 4-matic, 300 Turbo-D, 300 Turbo-D 4-matic	F8-5773	H=70; D=70
Repair Set, axle beam	260 E, 260 E 4-matic, 280 E, 300 E, 300 E 4-matic, 320 E	F8-5820	
Mounting, axle beam	260 E, 260 E 4-matic, 280 E, 300 E, 300 E 4-matic, 320 E	F8-5821	H=59; d=16; D=66
Rubber Buffer, suspension	200, 200 D, 200 E, 220 E, 230 E, 250 D, 250 Turbo-D, 260 E, 260 E 4-matic, 280 E, 300 D, 300 D 4-matic, 300 E, 300 E 4-matic, 300 E-24, 300 Turbo-D, 300 Turbo-D 4-matic, 320 E, 400 E 4.2, 500 E	F8-5901	
Rubber Buffer, suspension	200, 200 D, 200 E, 220 E, 230 E, 250 D, 250 Turbo-D, 260 E, 280 E, 300 D, 300 E, 300 E-24, 300 Turbo-D, 320 E	F8-5914	H=75
Rubber Buffer, suspension	200, 200 D, 200 E, 220 E, 230 E, 250 D, 250 Turbo-D, 260 E, 280 E, 300 D, 300 E, 300 E-24, 300 Turbo-D, 320 E, 400 E 4.2	F8-5918	
Stabiliser Mounting	200, 200 E, 220 E, 230 E	F8-5973	H=38,5; d=25; D=45
Repair Set, axle beam	200, 200 D, 200 E, 220 E, 230 E, 250 D, 250 Turbo-D, 260 E, 280 E, 300 D, 300 D 4-matic, 300 E, 300 Turbo-D, 300 Turbo-D 4-matic	with fastening material F8-6230	
Joint, propshaft	280 E	with fastening material; F8-6239	Bolt Hole Circle Ø [mm]=100; d=46; D=140; W=29.8
Joint, propshaft	280 E, 320 E	with fastening material F8-6239	Bolt Hole Circle Ø [mm]=100; d=46; D=140; W=29.8
Joint, propshaft	300 E-24	09/1989 →; with fastening material F8-6239	Bolt Hole Circle Ø [mm]=100; d=46; D=140; W=29.8



**Article Description****Article Nr.****Fitting Position**

<b>Saloon (W124)</b>				<b>12/1984 → 06/1993</b>	
Control Arm-/Trailing Arm Bush	200, 200 D, 200 E, 220 E, 230 E, 250 D, 250 Turbo-D, 260 E, 260 E 4-matic, 280 E, 300 AMG, 300 D, 300 D 4-matic, 300 E, 300 E 4-matic, 300 E-24, 300 TD SD, 300 Turbo-D, 300 Turbo-D 4-matic, 320 E, 400 E 4.2, 500 E, 500 E AMG 6.0		<b>F8-6468</b>		H=48; d=16; D=49
Suspension Kit	200 D, 200 E, 220 E, 230 E, 250 D, 250 Turbo-D, 260 E, 280 E, 300 D, 300 E, 300 E-24, 300 Turbo-D, 320 E		<b>F8-6473</b>		
Mounting, manual transmission	200, 200 D, 200 E, 220 E, 230 E, 250 D, 250 Turbo-D, 260 E, 260 E 4-matic, 280 E, 300 D, 300 D 4-matic, 300 E, 300 E 4-matic, 300 E-24, 300 Turbo-D, 300 Turbo-D 4-matic, 320 E, 400 E 4.2, 500 E		<b>F8-6498</b>		
Control Arm-/Trailing Arm Bush	200 D, 200 E, 220 E, 280 E, 320 E, 400 E 4.2, 500 E	ch.B711096→;	<b>F8-6804</b>		
Control Arm-/Trailing Arm Bush	200 E	ch.C018228→;	<b>F8-6804</b>		
Control Arm-/Trailing Arm Bush	200 E, 230 E, 250 D, 250 Turbo-D, 260 E, 300 D, 300 E, 300 E-24, 300 Turbo-D	ch.B711096→; 09/1989 →;	<b>F8-6804</b>		
Control Arm-/Trailing Arm Bush	220 E, 280 E, 320 E	ch.C018228→;	<b>F8-6804</b>		
Control Arm-/Trailing Arm Bush	200 D, 400 E 4.2, 500 E	ch.B711096→;	<b>F8-6805</b>		
Control Arm-/Trailing Arm Bush	200 E	ch.C018228→;	<b>F8-6805</b>		
Control Arm-/Trailing Arm Bush	200 E, 230 E, 250 D, 250 Turbo-D, 260 E, 300 D, 300 E, 300 E-24, 300 Turbo-D	ch.B711096→; 09/1989 →;	<b>F8-6805</b>		
Control Arm-/Trailing Arm Bush	220 E, 280 E, 320 E	ch.C018228→;	<b>F8-6805</b>		
Joint, propshaft	200, 200 D, 200 E, 220 E, 230 E, 250 D, 250 Turbo-D, 260 E, 260 E 4-matic, 300 D, 300 D 4-matic, 300 E, 300 E 4-matic	with add-on material	<b>F8-7130</b>		Bolt Hole Circle Ø [mm]=90
Control Arm-/Trailing Arm Bush	200, 200 D, 200 E, 220 E, 230 E, 250 D, 250 Turbo-D, 260 E, 260 E 4-matic, 280 E, 300 D, 300 D 4-matic, 300 E, 300 E 4-matic, 300 E-24, 300 Turbo-D, 300 Turbo-D 4-matic, 320 E, 400 E 4.2, 500 E		<b>G9-503</b>		H=43; d=12; D=31
Control Arm-/Trailing Arm Bush	200, 200 D, 200 E, 220 E, 230 E, 250 D, 250 Turbo-D, 260 E, 260 E 4-matic, 280 E, 300 D, 300 D 4-matic, 300 E, 300 E 4-matic, 300 E-24, 300 Turbo-D, 300 Turbo-D 4-matic, 320 E, 400 E 4.2, 500 E		<b>G9-651</b>		d=12
Control Arm-/Trailing Arm Bush	200, 200 D, 200 E, 220 E, 230 E, 250 D, 250 Turbo-D, 260 E, 260 E 4-matic, 280 E, 300 D, 300 D 4-matic, 300 E, 300 E 4-matic, 300 E-24, 300 Turbo-D, 300 Turbo-D 4-matic, 320 E, 400 E 4.2, 500 E		<b>G9-652</b>		d=13
<b>T1 Bus (601)</b>				<b>05/1977 → 02/1996</b>	
Bush, spring shackle	All Models		<b>F8-5205</b>		H=70; d=12; D=38
Stabiliser Mounting	207 D 2.4		<b>F8-5704</b>		d=24

<b>F8-5205</b>	<b>F8-5704</b>	<b>F8-5705</b>	<b>F8-6468</b>	<b>F8-6473</b>	<b>F8-6498</b>	<b>F8-6804</b>
Ref.Nr.: 0003210050	Ref.Nr.: 6013260482	Ref.Nr.: 6023260882	Ref.Nr.: 201 333 52 14	Ref.Nr.: 1243300975	Ref.Nr.: 1242400018	Ref.Nr.: 1243334214
<b>F8-6805</b>	<b>F8-7130</b>	<b>G9-503</b>	<b>G9-651</b>	<b>G9-652</b>		
Ref.Nr.: 1243334314	Ref.Nr.: 1264100515	Ref.Nr.: 1243524365	Ref.Nr.: 1243529065	Ref.Nr.: 1243528665		

Article Description



Article Nr.

Fitting Position



<b>T1 Bus (601)</b>			<b>05/1977 → 02/1996</b>	
Stabiliser Mounting	207 D 2.4, 208 D 2.3, 209 D 2.9, 210 D 2.8		<b>F8-5705</b>	H=48; d=32; D=52
Stabiliser Mounting	All Models		<b>F8-5752</b>	H=26; d=12; D=26
<b>T1 Box (601)</b>			<b>06/1982 → 02/1996</b>	
Mounting, propshaft	209 D 2.9, 210 D 2.8	☹; with add-on material, with seal	<b>F8-5014</b>	d=45
Bush, spring shackle	207 D 2.4, 208 D 2.3, 209 D 2.9, 210 2.3, 210 D 2.8		<b>F8-5205</b>	H=70; d=12; D=38
Stabiliser Mounting	207 D 2.4		<b>F8-5704</b>	d=24
Stabiliser Mounting	207 D 2.4, 208 D 2.3, 209 D 2.9, 210 2.3, 210 D 2.8		<b>F8-5705</b>	H=48; d=32; D=52
Stabiliser Mounting	209 D 2.9, 210 2.3, 210 D 2.8		<b>F8-5750</b>	H=48; d=32
Stabiliser Mounting	209 D 2.9, 210 2.3, 210 D 2.8		<b>F8-5751</b>	H=26; d=16; D=26
Stabiliser Mounting	207 D 2.4, 208 D 2.3, 209 D 2.9, 210 2.3, 210 D 2.8		<b>F8-5752</b>	H=26; d=12; D=26
Stabiliser Mounting	209 D 2.9, 210 2.3, 210 D 2.8		<b>F8-5753</b>	H=48; d=30
Mounting, leaf spring	209 D 2.9, 210 2.3, 210 D 2.8		<b>F8-5769</b>	H=70; d=12.5
Bellow Set, drive shaft	210 D 2.8	ch.→R1999999, R5299999, R7699999	<b>MK-822920</b>	
<b>T1 Platform/Chassis (601)</b>			<b>04/1977 → 02/1996</b>	
Clamp, silencer	207 D 2.4, 208 D 2.3, 210 2.3	ch.500001→; ch.→240087, 240106, 556499;	<b>F8-4027</b>	H=17; W=53, 61
Mounting, propshaft	207 D 2.4, 208 D 2.3, 209 D 2.9, 210 2.3, 210 D 2.9	☹; with add-on material, with seal	<b>F8-5014</b>	d=45
Bush, spring shackle	All Models		<b>F8-5205</b>	H=70; d=12; D=38
Stabiliser Mounting	207 D 2.4		<b>F8-5704</b>	d=24
Stabiliser Mounting	All Models		<b>F8-5705</b>	H=48; d=32; D=52
Stabiliser Mounting	All Models		<b>F8-5750</b>	H=48; d=32
Stabiliser Mounting	All Models		<b>F8-5751</b>	H=26; d=16; D=26
Stabiliser Mounting	All Models		<b>F8-5752</b>	H=26; d=12; D=26
Stabiliser Mounting	All Models		<b>F8-5753</b>	H=48; d=30
Mounting, leaf spring	All Models		<b>F8-5769</b>	H=70; d=12.5
<b>T1 Bus (602)</b>			<b>06/1989 → 02/1996</b>	
Bush, spring shackle	All Models		<b>F8-5205</b>	H=70; d=12; D=38
Stabiliser Mounting	All Models		<b>F8-5750</b>	H=48; d=32
Stabiliser Mounting	308 D 2.3		<b>F8-5751</b>	H=26; d=16; D=26
Stabiliser Mounting	All Models		<b>F8-5752</b>	H=26; d=12; D=26
Mounting, leaf spring	308 D 2.3		<b>F8-5769</b>	H=70; d=12.5
<b>T1 Box (602)</b>			<b>10/1982 → 02/1996</b>	
Bush, spring shackle	307 D 2.4, 308 D 2.3, 309 D 3.0, 310 D 2.9		<b>F8-5205</b>	H=70; d=12; D=38
Stabiliser Mounting	307 D 2.4		<b>F8-5704</b>	d=24







Article Description



Article Nr.

Fitting Position



			<b>10/1982 → 02/1996</b>		
<b>T1 Box (602)</b>					
Stabiliser Mounting	307 D 2.4, 308 D 2.3, 309 D 3.0, 310 D 2.9		<b>F8-5750</b>		H=48; d=32
Stabiliser Mounting	309 D 3.0		<b>F8-5751</b>		H=26; d=16; D=26
Stabiliser Mounting	307 D 2.4, 308 D 2.3, 309 D 3.0, 310 D 2.9		<b>F8-5752</b>		H=26; d=12; D=26
Mounting, leaf spring	309 D 3.0		<b>F8-5769</b>		H=70; d=12.5
<b>T1 Platform/Chassis (602)</b>					
<b>04/1977 → 02/1996</b>					
Clamp, silencer	307 D 2.4, 308 D 2.3	ch.500001→; ch.→240087, 240106, 556499;	<b>F8-4027</b>		H=17; W=53, 61
Mounting, propshaft	307 D 2.4, 308 D 2.3, 309 D 3.0, 310 D 2.9	; with add-on material, with seal	<b>F8-5014</b>		d=45
Bush, spring shackle	307 D 2.4, 308 D 2.3, 309 D 3.0, 310 D 2.9		<b>F8-5205</b>		H=70; d=12; D=38
Stabiliser Mounting	307 D 2.4		<b>F8-5704</b>		d=24
Stabiliser Mounting	307 D 2.4, 308 D 2.3, 309 D 3.0, 310 D 2.9		<b>F8-5750</b>		H=48; d=32
Stabiliser Mounting	307 D 2.4, 308 D 2.3, 309 D 3.0, 310 D 2.9		<b>F8-5751</b>		H=26; d=16; D=26
Stabiliser Mounting	307 D 2.4, 308 D 2.3, 309 D 3.0, 310 D 2.9		<b>F8-5752</b>		H=26; d=12; D=26
Mounting, leaf spring	307 D 2.4, 308 D 2.3, 309 D 3.0, 310 D 2.9		<b>F8-5769</b>		H=70; d=12.5
<b>T1/TN Box Body / Estate</b>					
<b>08/1982 → 06/1995</b>					
Control Arm-/Trailing Arm Bush	408 D , 410, 410 D	ch.543503→	<b>F8-5684</b>		H=80; d=16
<b>T1/TN Platform/Chassis</b>					
<b>08/1982 → 06/1995</b>					
Control Arm-/Trailing Arm Bush	408 D , 410, 410 D	ch.543503→	<b>F8-5684</b>		H=80; d=16
<b>T2/L Box Body / Estate</b>					
<b>01/1968 → 12/1974</b>					
Stabiliser Mounting	L 406 DG , L 408 DG		<b>F8-8101</b>		d=12; D=30
<b>T2/L Platform/Chassis</b>					
<b>01/1968 → 12/1974</b>					
Stabiliser Mounting	L 406 DG , L 408 DG		<b>F8-8101</b>		d=12; D=30
<b>T2/LN1 Box Body / Estate</b>					
<b>04/1986 → 12/1994</b>					
Stabiliser Mounting	611 D		<b>F8-5825</b>		d=33; L=54; D=49
Stabiliser Mounting	510	ch.852362→	<b>F8-8101</b>		d=12; D=30
<b>T2/LN1 Dumptruck</b>					
<b>06/1994 → 12/1994</b>					
Stabiliser Mounting	611 DK		<b>F8-5825</b>		d=33; L=54; D=49
<b>T2/LN1 Platform/Chassis</b>					
<b>04/1986 → 12/1994</b>					
Stabiliser Mounting	611 D		<b>F8-5825</b>		d=33; L=54; D=49
Stabiliser Mounting	507 D , 510	ch.852362→	<b>F8-8101</b>		d=12; D=30
<b>VANEO (414)</b>					
<b>02/2002 → 07/2005</b>					
Dust Cover Kit, shock absorber	1.6 , 1.7 CDI , 1.9		<b>AK-735221</b>		
Alternator Freewheel Clutch	All Models		<b>F5-1026</b>		

<b>AK-735221</b>	<b>F5-1026</b>	<b>F5-1121</b>	<b>F8-4027</b>	<b>F8-5014</b>	<b>F8-5205</b>	<b>F8-5684</b>
Ref.Nr.: 1683230192	Ref.Nr.: 1661550215	Ref.Nr.: 6681550215	Ref.Nr.: 171253147A	Ref.Nr.: 6014101210	Ref.Nr.: 0003210050	Ref.Nr.: 6113240350
<b>F8-5704</b>	<b>F8-5750</b>	<b>F8-5751</b>	<b>F8-5752</b>	<b>F8-5769</b>	<b>F8-5825</b>	<b>F8-8101</b>
Ref.Nr.: 6013260482	Ref.Nr.: 6023260282	Ref.Nr.: 6023210350	Ref.Nr.: 5103955AB	Ref.Nr.: 6013240050	Ref.Nr.: 6113260081	Ref.Nr.: 3093200073

Article Description



Article Nr.

Fitting Position



<b>VANEO (414)</b>		<b>02/2002 → 07/2005</b>	
Alternator Freewheel Clutch	1.7 CDI		F5-1121
Repair Kit, suspension strut	1.6 , 1.9		F8-5834
Belt Pulley, crankshaft	1.6	Number of Ribs: 5;	F8-6400
Belt Pulley, crankshaft	1.7 CDI , 1.9	Number of Ribs: 5	F8-6400
Engine Mounting	1.6 , 1.7 CDI , 1.9		F8-8126
<b>VARIO Bus</b>		<b>09/1996 →</b>	
Alternator Freewheel Clutch	O 812		F5-1099
<b>VARIO Box Body / Estate</b>		<b>09/1996 →</b>	
Alternator Freewheel Clutch	512 D		F5-1003
Alternator Freewheel Clutch	612 D , 812 D		F5-1099
<b>VARIO Dumptruck</b>		<b>09/1996 →</b>	
Alternator Freewheel Clutch	612 D , 812 D		F5-1099
<b>VARIO Platform/Chassis</b>		<b>09/1996 →</b>	
Alternator Freewheel Clutch	612 D , 613 D , 614 D , 812 D		F5-1099
<b>V-CLASS (638/2)</b>		<b>09/1996 → 07/2003</b>	
Alternator Freewheel Clutch	V 230 TD		F5-1001
Alternator Freewheel Clutch	V 200 CDI , V 220 CDI		F5-1017
Alternator Freewheel Clutch	V 200 CDI , V 220 CDI		F5-1019
Anti-Friction Bearing	V 200	M 111.948	F8-5962
Anti-Friction Bearing	V 230	M 111.978	F8-5962
Anti-Friction Bearing	V 230 TD , V 280		F8-5962
Top Strut Mounting	V 200 , V 230 , V 230 TD , V 280		F8-5967
Control Arm-/Trailing Arm Bush	All Models		F8-6057
Control Arm-/Trailing Arm Bush	All Models		F8-6135
Control Arm-/Trailing Arm Bush	All Models		F8-6135S
Control Arm-/Trailing Arm Bush	All Models		F8-6136
Stabiliser Mounting	All Models		F8-6231
Top Strut Mounting	All Models		F8-6380
Engine Mounting	V 200 , V 230 , V 230 TD		F8-6465
Bellow, steering	All Models	with clamps;	LM-10033S
<b>VIANO (W639)</b>		<b>09/2003 →</b>	
Dust Cover Kit, shock absorber	All Models		AK-735445

<b>AK-735445</b>	<b>F5-1001</b>	<b>F5-1003</b>	<b>F5-1017</b>	<b>F5-1019</b>	<b>F5-1099</b>	<b>F5-1121</b>
Ref.Nr.: 6393230298	Ref.Nr.: 211242	Ref.Nr.: 6041500060	Ref.Nr.: 6111500160	Ref.Nr.: 5117591AA	Ref.Nr.: 6041500460	Ref.Nr.: 6681550215
<b>F8-5834</b>	<b>F8-5962</b>	<b>F8-5967</b>	<b>F8-6057</b>	<b>F8-6135</b>	<b>F8-6135S</b>	<b>F8-6136</b>
Ref.Nr.: 1683200073	Ref.Nr.: 6389810120	Ref.Nr.: 6383230320	Ref.Nr.: 6383206650	Ref.Nr.: A6383330814	Ref.Nr.: A6383330814	Ref.Nr.: 6383330014
<b>F8-6231</b>	<b>F8-6380</b>	<b>F8-6400</b>	<b>F8-6465</b>	<b>F8-8126</b>	<b>LM-10033S</b>	
Ref.Nr.: 6383230285	Ref.Nr.: 6383230320	Ref.Nr.: 166 030 0303	Ref.Nr.: 6382411413	Ref.Nr.: A1682401617	Ref.Nr.: 9014620096	

**Article Description****Article Nr.****Fitting Position**

<b>VIANO (W639)</b>			<b>09/2003 →</b>	
Alternator Freewheel Clutch	CDI 2.0, CDI 2.0 4-matic, CDI 2.2, CDI 2.2 4-matic		<b>F5-1019</b>	
Alternator Freewheel Clutch	3.5		<b>F5-1056</b>	
Alternator Freewheel Clutch	CDI 3.0		<b>F5-1126</b>	
Belt Pulley, crankshaft	3, 3.2, 3.7	Parameter: 6PK	<b>F8-5663</b>	d=32; D1=160; D2=157; W1=82
Control Arm-/Trailing Arm Bush	3, 3.2, 3.7, CDI 2.0, CDI 2.0 4-matic, CDI 2.2, CDI 2.2 4-matic, CDI 3.0		<b>F8-6136</b>	
Stabiliser Mounting	3, 3.2, 3.7, CDI 2.0, CDI 2.2, CDI 2.2 4-matic, CDI 3.0		<b>F8-6231</b>	H1=40; H2=46; d=24; L=46
Engine Mounting	3, 3.2, 3.5, 3.7		<b>F8-6967</b>	
Anti-Friction Bearing	3, 3.2, 3.5, 3.7, CDI 2.0, CDI 2.2, CDI 3.0		<b>F8-7629</b>	
Top Strut Mounting	3, 3.2, 3.5, 3.7, CDI 2.0, CDI 2.2, CDI 3.0		<b>F8-7630</b>	
Control Arm-/Trailing Arm Bush	3, 3.2, 3.5, 3.7, CDI 2.0, CDI 2.2, CDI 3.0	ch.3603472→; 09/2010 →; XMO	<b>F8-8082</b>	H=60; d=14,5; D=70
Control Arm-/Trailing Arm Bush	3, 3.2, 3.5, 3.7, CDI 2.0, CDI 2.2, CDI 3.0	ch.3603472→; 09/2010 →; XMO; Paired article nr: F8-8084; with holder	<b>F8-8083</b>	H=61; d=15,1; Mounting points diam.[mm]=13; D=70,2
Control Arm-/Trailing Arm Bush	3, 3.2, 3.5, 3.7, CDI 2.0, CDI 2.2, CDI 3.0	ch.3603472→; 09/2010 →; XMO; Paired article nr: F8-8083; with holder	<b>F8-8084</b>	H=61; d=15,1; Mounting points diam.[mm]=13; D=70,2
<b>VITO Bus (638)</b>			<b>02/1996 → 07/2003</b>	
Dust Cover Kit, shock absorber	All Models		<b>AK-735010</b>	
Alternator Freewheel Clutch	108 D 2.3 , 110 TD 2.3		<b>F5-1001</b>	
Alternator Freewheel Clutch	108 CDI 2.2 , 110 CDI 2.2 , 112 CDI 2.2		<b>F5-1017</b>	
Alternator Freewheel Clutch	108 CDI 2.2 , 110 CDI 2.2 , 112 CDI 2.2		<b>F5-1019</b>	
Top Strut Mounting	All Models		<b>F8-5967</b>	
Control Arm-/Trailing Arm Bush	All Models		<b>F8-6057</b>	H=75; d=14,5; D=54
Control Arm-/Trailing Arm Bush	All Models		<b>F8-6135</b>	H=70; d=14; D=70
Control Arm-/Trailing Arm Bush	All Models		<b>F8-6135S</b>	H=70; d=14; D=70
Control Arm-/Trailing Arm Bush	All Models		<b>F8-6136</b>	
Stabiliser Mounting	All Models		<b>F8-6231</b>	H1=40; H2=46; d=24; L=46
Top Strut Mounting	All Models		<b>F8-6380</b>	
Engine Mounting	All Models		<b>F8-6465</b>	
Bellow, steering	All Models	with clamps;	<b>LM-10033S</b>	d1=13; d2=60; L [mm]=220
<b>VITO Box (638)</b>			<b>03/1997 → 07/2003</b>	
Dust Cover Kit, shock absorber	All Models		<b>AK-735010</b>	
Alternator Freewheel Clutch	108 D 2.3 , 110 D 2.3		<b>F5-1001</b>	
Alternator Freewheel Clutch	108 CDI 2.2 , 110 CDI 2.2 , 112 CDI 2.2		<b>F5-1017</b>	

<b>AK-735010</b>	<b>F5-1001</b>	<b>F5-1017</b>	<b>F5-1019</b>	<b>F5-1056</b>	<b>F5-1126</b>	<b>F8-5663</b>
Ref.Nr.:	Ref.Nr.: 211242	Ref.Nr.: 6111500160	Ref.Nr.: 5117591AA	Ref.Nr.: 2711550016	Ref.Nr.: 05175811AA	Ref.Nr.: 1120350800
<b>F8-5967</b>	<b>F8-6057</b>	<b>F8-6135</b>		<b>F8-6136</b>	<b>F8-6231</b>	<b>F8-6380</b>
Ref.Nr.: 6383230320	Ref.Nr.: 6383250650	Ref.Nr.: A6383330814	Ref.Nr.: A6383330814	Ref.Nr.: 6383330014	Ref.Nr.: 6383230285	Ref.Nr.: 6383230320
<b>F8-6465</b>	<b>F8-6967</b>	<b>F8-7629</b>	<b>F8-7630</b>			<b>F8-8084</b>
Ref.Nr.: 6382411413	Ref.Nr.: 6392410513	Ref.Nr.: 6399810025	Ref.Nr.: 6393230420	Ref.Nr.: 6393301307	Ref.Nr.: 6393301207	Ref.Nr.: 6393301501

Article Description



Article Nr.

Fitting Position



<b>VITO Box (638)</b>		<b>03/1997 → 07/2003</b>	
Alternator Freewheel Clutch	108 CDI 2.2, 110 CDI 2.2, 112 CDI 2.2		<b>F5-1019</b>
Anti-Friction Bearing	108 D 2.3, 110 D 2.3, 113 2.0, 114 2.3		<b>F8-5962</b>
Top Strut Mounting	All Models		<b>F8-5967</b>
Control Arm-/Trailing Arm Bush	108 CDI 2.2, 108 D 2.3, 110 CDI 2.2, 110 D 2.3, 113 2.0, 114 2.3		<b>F8-6057</b>
Control Arm-/Trailing Arm Bush	108 CDI 2.2, 108 D 2.3, 110 CDI 2.2, 110 D 2.3, 113 2.0, 114 2.3		<b>F8-6135</b>
Control Arm-/Trailing Arm Bush	108 CDI 2.2, 108 D 2.3, 110 CDI 2.2, 110 D 2.3, 113 2.0, 114 2.3		<b>F8-6135S</b>
Control Arm-/Trailing Arm Bush	All Models		<b>F8-6136</b>
Stabiliser Mounting	108 CDI 2.2, 108 D 2.3, 110 CDI 2.2, 110 D 2.3, 113 2.0, 114 2.3		<b>F8-6231</b>
Top Strut Mounting	All Models		<b>F8-6380</b>
Engine Mounting	All Models		<b>F8-6465</b>
Bellow, steering	All Models	with clamps;	<b>LM-10033S</b>
<b>VITO Bus (W639)</b>		<b>09/2003 →</b>	
Dust Cover Kit, shock absorber	109 CDI, 109 CDI 4x4, 110 CDI, 111 CDI, 111 CDI 4x4, 113 CDI, 113 CDI 4x4, 115 CDI, 115 CDI 4x4, 116 CDI, 116 CDI 4x4, 119, 120 CDI, 122, 122 CDI, 123, 126		<b>AK-735445</b>
Alternator Freewheel Clutch	109 CDI, 109 CDI 4x4, 110 CDI, 111 CDI, 111 CDI 4x4, 113 CDI, 115 CDI, 115 CDI 4x4, 116 CDI, 120 CDI		<b>F5-1019</b>
Alternator Freewheel Clutch	120 CDI, 122 CDI		<b>F5-1126</b>
Belt Pulley, crankshaft	119, 122, 123	Parameter: 6PK	<b>F8-5663</b>
Control Arm-/Trailing Arm Bush	109 CDI, 109 CDI 4x4, 111 CDI, 111 CDI 4x4, 115 CDI, 115 CDI 4x4, 119, 120 CDI, 122, 123, 126		<b>F8-6136</b>
Stabiliser Mounting	109 CDI, 109 CDI 4x4, 111 CDI, 120 CDI, 122		<b>F8-6231</b>
Anti-Friction Bearing	109 CDI, 111 CDI, 113 CDI, 115 CDI, 119, 120 CDI, 122, 123, 126		<b>F8-7629</b>
Top Strut Mounting	109 CDI, 111 CDI, 113 CDI, 115 CDI, 119, 120 CDI, 122, 123, 126		<b>F8-7630</b>
Control Arm-/Trailing Arm Bush	109 CDI, 111 CDI, 115 CDI, 119, 120 CDI, 122, 123, 126	ch.3603472→; 09/2010 →; XM0	<b>F8-8082</b>
Control Arm-/Trailing Arm Bush	110 CDI, 113 CDI, 116 CDI, 122 CDI		<b>F8-8082</b>
Control Arm-/Trailing Arm Bush	109 CDI, 111 CDI, 115 CDI, 119, 120 CDI, 122, 123, 126	ch.3603472→; 09/2010 →; XM0; Paired article nr: F8-8084; with holder	<b>F8-8083</b>
Control Arm-/Trailing Arm Bush	110 CDI, 113 CDI, 116 CDI, 122 CDI	Paired article nr: F8-8084; with holder	<b>F8-8083</b>
Control Arm-/Trailing Arm Bush	109 CDI, 111 CDI, 115 CDI, 119, 120 CDI, 122, 123, 126	ch.3603472→; 09/2010 →; XM0; Paired article nr: F8-8083; with holder	<b>F8-8084</b>



**Article Description****Article Nr.****Fitting Position**

<b>VITO Bus (W639)</b>			<b>09/2003 →</b>		
Control Arm-/Trailing Arm Bush	110 CDI, 113 CDI, 116 CDI, 122 CDI	Paired article nr: F8-8083; with holder	<b>F8-8084</b>		H=61; d=15,1; Mounting points diam.[mm]=13; D=70,2
<b>VITO / MIXTO Box (W639)</b>			<b>09/2003 → 07/2008</b>		
Dust Cover Kit, shock absorber	109 CDI, 110 CDI, 111 CDI, 111 CDI 4x4, 113 CDI, 115 CDI, 115 CDI 4x4, 116 CDI, 119, 120 CDI, 122, 122 CDI, 123, 126		<b>AK-735445</b>		
Alternator Freewheel Clutch	109 CDI, 110 CDI, 111 CDI, 111 CDI 4x4, 113 CDI, 115 CDI, 115 CDI 4x4, 116 CDI, 120 CDI		<b>F5-1019</b>		
Alternator Freewheel Clutch	120 CDI, 122 CDI		<b>F5-1126</b>		
Belt Pulley, crankshaft	119, 122, 123	Parameter: 6PK	<b>F8-5663</b>		d=32; D1=160; D2=157; W1=82
Control Arm-/Trailing Arm Bush	109 CDI, 111 CDI, 111 CDI 4x4, 115 CDI, 115 CDI 4x4, 119, 120 CDI, 122, 123, 126		<b>F8-6136</b>		
Stabiliser Mounting	109 CDI, 111 CDI, 115 CDI, 119, 120 CDI, 122		<b>F8-6231</b>		H1=40; H2=46; d=24; L=46
Anti-Friction Bearing	109 CDI, 111 CDI, 113 CDI, 115 CDI, 119, 120 CDI, 122, 123, 126		<b>F8-7629</b>		
Top Strut Mounting	109 CDI, 111 CDI, 113 CDI, 115 CDI, 119, 120 CDI, 122, 123, 126		<b>F8-7630</b>		
Control Arm-/Trailing Arm Bush	109 CDI, 111 CDI, 115 CDI, 119, 120 CDI, 122, 126	ch.3603472→; 09/2010 →; XM0	<b>F8-8082</b>		H=60; d=14,5; D=70
Control Arm-/Trailing Arm Bush	110 CDI, 113 CDI, 116 CDI, 122 CDI		<b>F8-8082</b>		H=60; d=14,5; D=70
Control Arm-/Trailing Arm Bush	109 CDI, 111 CDI, 115 CDI, 119, 120 CDI, 122, 126	ch.3603472→; 09/2010 →; XM0; Paired article nr: F8-8084; with holder	<b>F8-8083</b>		H=61; d=15,1; Mounting points diam.[mm]=13; D=70,2
Control Arm-/Trailing Arm Bush	110 CDI, 113 CDI, 116 CDI, 122 CDI	Paired article nr: F8-8084; with holder	<b>F8-8083</b>		H=61; d=15,1; Mounting points diam.[mm]=13; D=70,2
Control Arm-/Trailing Arm Bush	109 CDI, 111 CDI, 115 CDI, 119, 120 CDI, 122, 126	ch.3603472→; 09/2010 →; XM0; Paired article nr: F8-8083; with holder	<b>F8-8084</b>		H=61; d=15,1; Mounting points diam.[mm]=13; D=70,2
Control Arm-/Trailing Arm Bush	110 CDI, 113 CDI, 116 CDI, 122 CDI	Paired article nr: F8-8083; with holder	<b>F8-8084</b>		H=61; d=15,1; Mounting points diam.[mm]=13; D=70,2
<b>SPRINTER CLASSIC 3,5-t Box (909)</b>			<b>09/2013 →</b>		
Alternator Freewheel Clutch	All Models		<b>F5-1019</b>		
Engine Mounting	All Models		<b>F8-8147</b>		
<b>C-CLASS T-Model (S205)</b>			<b>09/2014 →</b>		
Alternator Freewheel Clutch	C 180 BlueTEC, C 200 BlueTEC		<b>F5-1126</b>		
<b>SPRINTER CLASSIC 4,6-t Bus (909)</b>			<b>09/2013 →</b>		
Alternator Freewheel Clutch	All Models		<b>F5-1019</b>		
Engine Mounting	All Models		<b>F8-8147</b>		

<b>AK-735445</b>	<b>F5-1019</b>	<b>F5-1126</b>	<b>F8-5663</b>	<b>F8-6136</b>	<b>F8-6231</b>	<b>F8-7629</b>
Ref.Nr.: 6393230298	Ref.Nr.: 5117591AA	Ref.Nr.: 05175811AA	Ref.Nr.: 1120350800	Ref.Nr.: 6383330014	Ref.Nr.: 6383230285	Ref.Nr.: 6399810025
<b>F8-7630</b>	<b>F8-8082</b>	<b>F8-8083</b>	<b>F8-8084</b>	<b>F8-8147</b>		
Ref.Nr.: 6393230420	Ref.Nr.: 6393301307	Ref.Nr.: 6393301207	Ref.Nr.: 6393301501	Ref.Nr.: 2D0199379A		

Article Description



Article Nr.

Fitting Position



<b>MG 6 Hatchback</b>		<b>08/2012 →</b>	
Stabiliser Mounting	2.5 CRDi	<b>F8-7066</b>	
<b>MG 6 Saloon</b>		<b>08/2012 →</b>	
Stabiliser Mounting	2.5 CRDi 4WD	<b>F8-7066</b>	
<b>MG ZT</b>		<b>06/2001 → 07/2005</b>	
Control Arm-/Trailing Arm Bush	1.8 16V, 160, 180, 190, 2.0 CDTi	<b>F8-8003</b>	
Control Arm-/Trailing Arm Bush	1.8 16V, 160, 180, 190, 2.0 CDTi	<b>F8-8004</b>	
<b>MG ZT- T</b>		<b>10/2001 → 07/2005</b>	
Control Arm-/Trailing Arm Bush	1.8 16V, 1.8 T 16V, 160, 180, 190, 2.0 CDTi	<b>F8-8003</b>	
Control Arm-/Trailing Arm Bush	1.8 16V, 1.8 T 16V, 160, 180, 190, 2.0 CDTi	<b>F8-8004</b>	

<b>F8-7066</b>	<b>F8-8003</b>	<b>F8-8004</b>
Ref.Nr.: 54813-3K100	Ref.Nr.: RBX101761	Ref.Nr.: RBX101771

**Article Description****Article Nr.****Fitting Position**

<b>MINI (R50, R53)</b>			<b>06/2001 → 09/2006</b>		
Dust Cover Kit, shock absorber	Cooper, Cooper S, One, One D		<b>AK-735228</b>		
Dust Cover Kit, shock absorber	Cooper, Cooper S, One, One D		<b>AK-735229</b>		
Alternator Freewheel Clutch	One D	Alternator Charge Current [A]: 130; ⚡	<b>F5-1137</b>		
Control Arm-/Trailing Arm Bush	1.4, Cooper, Cooper S, One, One D, S Works, Works	without holder	<b>F8-5298</b>		H=61; D=66
Top Strut Mounting	1.4, Cooper S, One D, Works		<b>F8-6368</b>		
Top Strut Mounting	Cooper, One	03/2002 →;	<b>F8-6368</b>		
Control Arm-/Trailing Arm Bush	Cooper, Cooper S, One, One D, Works	Paired article nr: F8-6575	<b>F8-6574</b>		
Control Arm-/Trailing Arm Bush	Cooper, Cooper S, One, One D, Works	Paired article nr: F8-6574	<b>F8-6575</b>		
Top Strut Mounting	1.4, Cooper, Cooper S, John Cooper Works, One, One D, Works		<b>F8-7464</b>		
<b>MINI Convertible (R52)</b>			<b>07/2004 → 11/2007</b>		
Dust Cover Kit, shock absorber	Cooper, Cooper S, John Cooper Works, One		<b>AK-735230</b>		
Dust Cover Kit, shock absorber	Cooper, Cooper S, John Cooper Works, One		<b>AK-735231</b>		
Control Arm-/Trailing Arm Bush	Cooper, Cooper S, John Cooper Works, One	without holder	<b>F8-5298</b>		H=61; D=66
Top Strut Mounting	Cooper, Cooper S, John Cooper Works, One		<b>F8-6368</b>		
Control Arm-/Trailing Arm Bush	Cooper, Cooper S, John Cooper Works, One	Paired article nr: F8-6575	<b>F8-6574</b>		
Control Arm-/Trailing Arm Bush	Cooper, Cooper S, John Cooper Works, One	Paired article nr: F8-6574	<b>F8-6575</b>		
Top Strut Mounting	Cooper, Cooper S, One		<b>F8-7464</b>		
<b>MINI (R56)</b>			<b>10/2006 → 11/2013</b>		
Alternator Freewheel Clutch	Cooper, Cooper S, John Cooper Works, John Cooper Works GP, One		<b>F5-1113</b>		
Protective Cap/Bellow, shock absorber	All Models	Universal	<b>F8-6545</b>		H=140
Belt Pulley, crankshaft	Cooper D	Number of Ribs: 6	<b>F8-7082</b>		Belt Pulley Ø [mm]=152; Mounting points diam.[mm]=30; W=34
Protective Cap/Bellow, shock absorber	All Models	Available as universal article: F8-6545	<b>F8-7336</b>		H=136
Top Strut Mounting	Cooper, Cooper D, Cooper S, John Cooper Works, One, One D		<b>F8-7464</b>		
Rubber Buffer, suspension	All Models		<b>F8-7705</b>		H=60
Rubber Buffer, suspension	Cooper, Cooper D, Cooper S, Cooper SD, One, One D	<b>SP, ST</b>	<b>F8-7710</b>		H=56
Rubber Buffer, suspension	John Cooper Works		<b>F8-7710</b>		H=56
Top Strut Mounting	All Models		<b>F8-7837</b>		

<b>AK-735228</b>	<b>AK-735229</b>	<b>AK-735230</b>	<b>AK-735231</b>	<b>F5-1113</b>	<b>F5-1137</b>	<b>F8-5298</b>
Ref.Nr.: 31330146239	Ref.Nr.: 33531507254	Ref.Nr.: 31330146239	Ref.Nr.: 33531507254	Ref.Nr.: 12317576515	Ref.Nr.: 12317790877	Ref.Nr.: 31126757551
<b>F8-6368</b>	<b>F8-6545</b>	<b>F8-6574</b>	<b>F8-6575</b>	<b>F8-7082</b>	<b>F8-7336</b>	<b>F8-7464</b>
Ref.Nr.: 31306764884	Ref.Nr.: 0146239	Ref.Nr.: 31126757561	Ref.Nr.: 31126757562	Ref.Nr.: 0515.R0	Ref.Nr.: 31331094749	Ref.Nr.: 3350-6789027
<b>F8-7705</b>	<b>F8-7710</b>	<b>F8-7837</b>	<b>F8-8205</b>			
Ref.Nr.: 31306777049	Ref.Nr.: 33536772740	Ref.Nr.: 31306772749	Ref.Nr.: 31126772235			

**Article Description**

**Article Nr.**
**Fitting Position**

<b>MINI (R56)</b>				<b>10/2006 → 11/2013</b>	
Control Arm-/Trailing Arm Bush	Cooper, Cooper D, Cooper S, Cooper SD, One, One D	Paired article nr: F8-8206; with rubber mounting; with holder	<b>F8-8205</b>		Mounting points diam.[mm]=17
Control Arm-/Trailing Arm Bush	Cooper, Cooper D, Cooper S, Cooper SD, One, One D	Paired article nr: F8-8205; with rubber mounting; with holder	<b>F8-8206</b>		Mounting points diam.[mm]=17
<b>MINI Convertible (R57)</b>				<b>03/2008 →</b>	
Alternator Freewheel Clutch	Cooper, Cooper S, John Cooper Works, One		<b>F5-1113</b>		
Protective Cap/Bellow, shock absorber	All Models	Universal	<b>F8-6545</b>		H=140
Protective Cap/Bellow, shock absorber	All Models	Available as universal article: F8-6545	<b>F8-7336</b>		H=136
Top Strut Mounting	Cooper, Cooper S, John Cooper Works, One		<b>F8-7464</b>		
Rubber Buffer, suspension	All Models		<b>F8-7705</b>		H=60
Top Strut Mounting	All Models		<b>F8-7837</b>		
Control Arm-/Trailing Arm Bush	Cooper, Cooper D, Cooper S, Cooper SD, One	Paired article nr: F8-8206; with rubber mounting; with holder	<b>F8-8205</b>		Mounting points diam.[mm]=17
Control Arm-/Trailing Arm Bush	Cooper, Cooper D, Cooper S, Cooper SD, One	Paired article nr: F8-8205; with rubber mounting; with holder	<b>F8-8206</b>		Mounting points diam.[mm]=17
<b>MINI CLUBMAN (R55)</b>				<b>10/2007 → 06/2015</b>	
Alternator Freewheel Clutch	Cooper, Cooper S, John Cooper Works, One		<b>F5-1113</b>		
Protective Cap/Bellow, shock absorber	Cooper, Cooper D, Cooper S, Cooper SD, John Cooper Works, One, One D	Universal	<b>F8-6545</b>		H=140
Belt Pulley, crankshaft	Cooper D	Number of Ribs: 6	<b>F8-7082</b>		Belt Pulley Ø [mm]=152; Mounting points diam.[mm]=30; W=34
Protective Cap/Bellow, shock absorber	Cooper, Cooper D, Cooper S, Cooper SD, John Cooper Works, One, One D	Available as universal article: F8-6545	<b>F8-7336</b>		H=136
Top Strut Mounting	Cooper, Cooper D, Cooper S, John Cooper Works, One		<b>F8-7464</b>		
Rubber Buffer, suspension	Cooper, Cooper D, Cooper S, Cooper SD, John Cooper Works, One, One D		<b>F8-7705</b>		H=60
Top Strut Mounting	Cooper, Cooper D, Cooper S, Cooper SD, John Cooper Works, One, One D		<b>F8-7837</b>		
Control Arm-/Trailing Arm Bush	Cooper, Cooper D, Cooper S, Cooper SD, One, One D	Paired article nr: F8-8206; with rubber mounting; with holder	<b>F8-8205</b>		Mounting points diam.[mm]=17
Control Arm-/Trailing Arm Bush	Cooper, Cooper D, Cooper S, Cooper SD, One, One D	Paired article nr: F8-8205; with rubber mounting; with holder	<b>F8-8206</b>		Mounting points diam.[mm]=17
<b>MINI CLUBVAN (R55)</b>				<b>12/2012 →</b>	
Alternator Freewheel Clutch	Cooper, One		<b>F5-1113</b>		
Control Arm-/Trailing Arm Bush	All Models	Paired article nr: F8-8206; with rubber mounting; with holder	<b>F8-8205</b>		Mounting points diam.[mm]=17
Control Arm-/Trailing Arm Bush	All Models	Paired article nr: F8-8205; with rubber mounting; with holder	<b>F8-8206</b>		Mounting points diam.[mm]=17





**Article Description****Article Nr.****Fitting Position**

<b>MINI COUNTRYMAN (R60)</b>			<b>06/2010 →</b>		
Protective Cap/Bellow, shock absorber	Cooper, Cooper D, Cooper D ALL4, Cooper S, Cooper S ALL4, Cooper S JCW, Cooper SD, Cooper SD ALL4, One, One D	Universal	<b>F8-6545</b>		H=140
Protective Cap/Bellow, shock absorber	Cooper, Cooper D, Cooper D ALL4, Cooper S, Cooper S ALL4, Cooper S JCW, Cooper SD, Cooper SD ALL4, One, One D	Available as universal article: F8-6545	<b>F8-7336</b>		H=136
Rubber Buffer, suspension	Cooper, Cooper D, Cooper D ALL4, Cooper S, Cooper S ALL4, Cooper SD, Cooper SD ALL4, One, One D	<b>SP</b>	<b>F8-7710</b>		H=56
Top Strut Mounting	Cooper, Cooper D, Cooper D ALL4, Cooper S, Cooper S ALL4, Cooper S JCW, Cooper SD, Cooper SD ALL4, One, One D		<b>F8-7837</b>		
<b>MINI Coupe (R58)</b>			<b>09/2011 →</b>		
Alternator Freewheel Clutch	Cooper, Cooper S, John Cooper Works		<b>F5-1113</b>		
Protective Cap/Bellow, shock absorber	All Models	Universal	<b>F8-6545</b>		H=140
Protective Cap/Bellow, shock absorber	All Models	Available as universal article: F8-6545	<b>F8-7336</b>		H=136
Rubber Buffer, suspension	All Models		<b>F8-7705</b>		H=60
Rubber Buffer, suspension	All Models	<b>SP</b>	<b>F8-7710</b>		H=56
Top Strut Mounting	All Models		<b>F8-7837</b>		
Control Arm-/Trailing Arm Bush	Cooper, Cooper S, Cooper SD	Paired article nr: F8-8206; with rubber mounting; with holder	<b>F8-8205</b>		Mounting points diam.[mm]=17
Control Arm-/Trailing Arm Bush	Cooper, Cooper S, Cooper SD	Paired article nr: F8-8205; with rubber mounting; with holder	<b>F8-8206</b>		Mounting points diam.[mm]=17
<b>MINI PACEMAN (R61)</b>			<b>04/2012 →</b>		
Protective Cap/Bellow, shock absorber	Cooper, Cooper D, Cooper D ALL4, Cooper S, Cooper S ALL4, Cooper SD, Cooper SD ALL4, John Cooper Works	Universal	<b>F8-6545</b>		H=140
Protective Cap/Bellow, shock absorber	Cooper, Cooper D, Cooper D ALL4, Cooper S, Cooper S ALL4, Cooper SD, Cooper SD ALL4, John Cooper Works	Available as universal article: F8-6545	<b>F8-7336</b>		H=136
Rubber Buffer, suspension	Cooper, Cooper D, Cooper D ALL4, Cooper S, Cooper S ALL4, Cooper SD, Cooper SD ALL4	<b>SP</b>	<b>F8-7710</b>		H=56
Rubber Buffer, suspension	John Cooper Works		<b>F8-7710</b>		H=56
Top Strut Mounting	Cooper, Cooper D, Cooper D ALL4, Cooper S, Cooper S ALL4, Cooper SD, Cooper SD ALL4, John Cooper Works		<b>F8-7837</b>		
<b>MINI Roadster (R59)</b>			<b>02/2012 →</b>		
Alternator Freewheel Clutch	Cooper, Cooper S, John Cooper Works		<b>F5-1113</b>		
Protective Cap/Bellow, shock absorber	All Models	Universal	<b>F8-6545</b>		H=140
Protective Cap/Bellow, shock absorber	All Models	Available as universal article: F8-6545	<b>F8-7336</b>		H=136

<b>F5-1113</b>	<b>F8-6545</b>	<b>F8-7336</b>	<b>F8-7705</b>	<b>F8-7710</b>	<b>F8-7837</b>	<b>F8-8205</b>
Ref.Nr.: 12317576515	Ref.Nr.: 0146239	Ref.Nr.: 31331094749	Ref.Nr.: 31306777049	Ref.Nr.: 33536772740	Ref.Nr.: 31306772749	Ref.Nr.: 31126772235
<b>F8-8206</b>						
Ref.Nr.: 31126772236						

Article Description



Article Nr.

Fitting Position



**MINI Roadster (R59)**

02/2012 →

Rubber Buffer, suspension	All Models		<b>F8-7705</b>	⊕ ⊕	H=60
Top Strut Mounting	All Models		<b>F8-7837</b>	⊕ ⊕	
Control Arm-/Trailing Arm Bush	Cooper, Cooper S, Cooper SD	Paired article nr: F8-8206; with rubber mounting; with holder	<b>F8-8205</b>	⊕	Mounting points diam.[mm]=17
Control Arm-/Trailing Arm Bush	Cooper, Cooper S, Cooper SD	Paired article nr: F8-8205; with rubber mounting; with holder	<b>F8-8206</b>	⊕	Mounting points diam.[mm]=17

<b>F8-7705</b>	<b>F8-7837</b>	<b>F8-8205</b>	<b>F8-8206</b>
Ref.Nr.: 31306777049	Ref.Nr.: 31306772749	Ref.Nr.: 31126772235	Ref.Nr.: 31126772236



Article Description



Article Nr.

Fitting Position



<b>CANTER Platform/Chassis (FB_, FE_, FG_)</b>		08/2005 → 11/2010	
Alternator Freewheel Clutch	3.0	F5-1144	
<b>CARISMA (DA_)</b>		07/1995 → 06/2006	
Dust Cover Kit, shock absorber	All Models	AK-735024	⊕ ⊕
Dust Cover Kit, shock absorber	All Models	AK-735121	⊕ ⊕
Alternator Freewheel Clutch	1.9 DI-D	F5-1025	
Control Arm-/Trailing Arm Bush	1.6, 1.8, 1.8 16V, 1.8 16V GDI, 1.8 GDI, 1.9 TD	F8-5249	⊕ ⊕ H=60; d=12; D=37
<b>CARISMA Saloon (DA_)</b>		09/1996 → 06/2006	
Dust Cover Kit, shock absorber	1.6, 1.8, 1.8 16V GDI, 1.8 GDI, 1.9 DI-D, 1.9 TD, 2.0 16V GT EVO VIVII	AK-735024	⊕ ⊕
Dust Cover Kit, shock absorber	1.6, 1.8, 1.8 16V GDI, 1.8 GDI, 1.9 DI-D, 1.9 TD	AK-735121	⊕ ⊕
Alternator Freewheel Clutch	1.9 DI-D	F5-1025	
Control Arm-/Trailing Arm Bush	1.6, 1.8, 1.8 16V GDI, 1.8 GDI, 1.9 TD	F8-5249	⊕ ⊕ H=60; d=12; D=37
<b>COLT Mk II (C1_A)</b>		02/1984 → 04/1988	
Dust Cover Kit, shock absorber	1.2 EL, GL, 1.5 GLX, 1.6 Turbo ECi, 1.8 GL Diesel	AK-735022	⊕ ⊕
Dust Cover Kit, shock absorber	1.5 GLX, 1.8 GL Diesel	AK-735022	⊕ ⊕ 06/1986 →
Dust Cover Kit, shock absorber	1.2 EL, GL, 1.5 GLX, 1.6 Turbo ECi, 1.8 GL Diesel	AK-735086	⊕ ⊕
Bellow, steering	1.2 EL, GL, 1.5 GLX, 1.6 Turbo ECi, 1.8 GL Diesel	LM-10016S	d1=11; d2=46; L [mm]=185 with clamps; ⊕
<b>COLT Mk III (C5_A)</b>		04/1988 → 05/1992	
Dust Cover Kit, shock absorber	All Models	AK-735023	⊕ ⊕ ⊕ L=140
Top Strut Mounting	1.3, 1.3 12V, 1.5, 1.5 GLXi, 1.6 GTi 16V, 1.8 Diesel GLX, 1.8 GTi 16V	F8-6372	
<b>COLT Mk IV (CA_A)</b>		04/1992 → 04/1996	
Dust Cover Kit, shock absorber	1.3 GLi 12V, 1.6, 1.6 4x4, 1.6 GLXi 16V	AK-735233	⊕ ⊕ ⊕
Dust Cover Kit, shock absorber	1.8 GTi 16V	AK-735234	⊕ ⊕ ⊕
Dust Cover Kit, shock absorber	1.3 GLi 12V, 1.6, 1.6 GLXi 16V, 1.8 GTi 16V	AK-735235	⊕ ⊕ ⊕
Top Strut Mounting	1.3 GLi 12V, 1.6 GLXi 16V, 1.8 GTi 16V	F8-6373	
Rod/Strut, wheel suspension	All Models	F8-6469	⊕ ⊕ ⊕ ↓ L=143
Control Arm-/Trailing Arm Bush	1.3 GLi 12V, 1.6, 1.6 GLXi 16V, 1.8 GTi 16V	F8-6696	⊕ ⊕
Control Arm-/Trailing Arm Bush	1.3 GLi 12V, 1.6, 1.6 GLXi 16V, 1.8 GTi 16V	F8-6772	⊕ ⊕ H=49.5; d=12.2; D1=36.2; D2=34.7
<b>COLT Mk V (CJ_, CP_)</b>		09/1995 → 09/2003	
Dust Cover Kit, shock absorber	1.3, 1.5, 1300, 1300 GL, GLX, 1500, 1600, 1600 GLX	AK-735235	⊕ ⊕ ⊕
Dust Cover Kit, shock absorber	1.3, 1.5, 1300, 1300 GL, GLX, 1500, 1600, 1600 GLX	AK-735236	⊕ ⊕ ⊕

<b>AK-735022</b>	<b>AK-735023</b>	<b>AK-735024</b>	<b>AK-735086</b>	<b>AK-735121</b>	<b>AK-735233</b>	<b>AK-735234</b>
Ref.Nr.:	Ref.Nr.: MB303070	Ref.Nr.:	Ref.Nr.:	Ref.Nr.:	Ref.Nr.: MB303069	Ref.Nr.: MB303070
<b>AK-735235</b>	<b>AK-735236</b>	<b>F5-1025</b>	<b>F5-1144</b>	<b>F8-5249</b>	<b>F8-6372</b>	<b>F8-6373</b>
Ref.Nr.: MB809284	Ref.Nr.: MR197462	Ref.Nr.: 23151-00Q0B	Ref.Nr.:	Ref.Nr.: 30818467	Ref.Nr.: MB518798	Ref.Nr.: MB808306
<b>F8-6469</b>	<b>F8-6696</b>	<b>F8-6772</b>	<b>LM-10016S</b>			
Ref.Nr.: 30620785	Ref.Nr.: MR102063	Ref.Nr.: 30620972	Ref.Nr.: MB501711			

Article Description



Article Nr.

Fitting Position



Article Description		Article Nr.	Fitting Position	09/1995 → 09/2003
<b>COLT Mk V (CJ_, CP_) 09/1995 → 09/2003</b>				
Control Arm-/Trailing Arm Bush	1300, 1300 GL, GLX, 1500, 1600, 1600 GLX	F8-6696		
Control Arm-/Trailing Arm Bush	1300, 1300 GL, GLX, 1500, 1600, 1600 GLX	F8-6772		H=49.5; d=12.2; D1=36.2; D2=34.7
<b>COLT VI (Z3_A, Z2_A) 06/2004 → 06/2012</b>				
Dust Cover Kit, shock absorber	1.1, 1.3, 1.5, 1.5 CZT, 1.5 DI-D	AK-735232		
<b>COLT CZC Convertible (RG) 05/2006 → 07/2009</b>				
Dust Cover Kit, shock absorber	All Models	AK-735232		
<b>CORDIA (A21_A, AB) 10/1982 → 12/1986</b>				
Dust Cover Kit, shock absorber	All Models	AK-735086		
Bellow, steering	All Models	LM-10016S		d1=11; d2=46; L [mm]=185
<b>ECLIPSE (D2_A) 12/1989 → 11/1995</b>				
Bellow, steering	1.8, 2.0 Turbo 4WD	LM-10016S		d1=11; d2=46; L [mm]=185
Bellow, steering	2.0 i 16V, 2.0 i 16V 4x4	LM-10016S		d1=11; d2=46; L [mm]=185
<b>ECLIPSE Mk II (D3_A) 12/1995 → 04/1999</b>				
Bellow, steering	2000 GS 16V, 2000 GT 16V, 2400 GS 16V	LM-10016S		d1=11; d2=46; L [mm]=185
<b>GALANT Mk III (E1_A) 06/1984 → 04/1990</b>				
Dust Cover Kit, shock absorber	1.6 GLX, 1.8 Turbo-D, 2.0 GLS	AK-735024		
Bellow, steering	1.6 GLX, 1.8 Turbo-D, 2.0 GLS, 2.0 Turbo ECi, 2.4 GLS	LM-10016S		d1=11; d2=46; L [mm]=185
<b>GALANT Mk IV (E3_A) 11/1988 → 12/1992</b>				
Dust Cover Kit, shock absorber	1.8, 1.8 Turbo-D, 2.0, 2.0 GTI 16V	AK-735024		
Bellow, steering	1.8, 1.8 Turbo-D, 2.0, 2.0 4x4, 2.0 GTI 16V, 2.0 GTI 16V 4x4	LM-10016S		d1=11; d2=46; L [mm]=185
<b>GALANT Mk IV Saloon (E3_A) 11/1987 → 10/1992</b>				
Dust Cover Kit, shock absorber	1.8, 1.8 Turbo-D, 2.0, 2.0 GTI 16V	AK-735024		
Bellow, steering	1.8, 1.8 Turbo-D, 2.0, 2.0 4x4, 2.0 GTI 16V, 2.0 GTI 16V 4x4	LM-10016S		d1=11; d2=46; L [mm]=185
<b>GALANT Mk V (E5_A, E7_A, E8_A) 11/1992 → 09/1996</b>				
Bellow, steering	1.8, 1.8 GLSI, 2.0 GLSI, 2.0 GLSI 4x4, 2.0 GLSTD, 2.0 V6-24	LM-10016S		d1=11; d2=46; L [mm]=185
Bellow, steering	2.0, 2.5, 2.5 V6-24 4x4	LM-10016S		d1=11; d2=46; L [mm]=185
<b>GALANT Mk V Saloon (E5_A, E7_A, E8_A) 11/1992 → 08/1996</b>				
Bellow, steering	1.8, 1.8 GLSI, 2.0 GLSI, 2.0 GLSI 4x4, 2.0 GLSTD, 2.0 V6-24	LM-10016S		d1=11; d2=46; L [mm]=185
Bellow, steering	2.5 V6-24 4x4	LM-10016S		d1=11; d2=46; L [mm]=185



**Article Description****Article Nr.****Fitting Position**

<b>GALANT Mk VI (EA_)</b>			<b>09/1996 → 10/2004</b>		
Bellow, steering	1.8 GDI, 2.5 Type S	with clamps	LM-10016S		d1=11; d2=46; L [mm]=185
Bellow, steering	2.0, 2.0 TDI, 2.4 GDI, 2.5 V6 24V	with clamps;	LM-10016S		d1=11; d2=46; L [mm]=185
<b>GALANT Mk VI Estate (EA_)</b>			<b>09/1996 → 10/2003</b>		
Bellow, steering	2.0, 2.0 TDI, 2.4 GDI, 2.5 V6 24V	with clamps;	LM-10016S		d1=11; d2=46; L [mm]=185
<b>L 200 (K7_T, K6_T)</b>			<b>06/1996 → 12/2007</b>		
Belt Pulley, crankshaft	2.5 D, 2.5 TD 4WD		F8-7860		Belt Pulley Ø [mm]=173; H1=31; H2=51
Belt Pulley, crankshaft	2.5 D	07/2001 →	F8-7870		
Belt Pulley, crankshaft	2.5 TD 4WD		F8-7870		
Stabiliser Mounting	2.5 TD 4WD, 2.5 TD 4x4, 3.0 4x4		F8-8034		d=20
<b>L 300 Bus (P0_W, P1_W, P2_W)</b>			<b>11/1986 → 08/1997</b>		
Bellow, steering	2.4 GLX 4x4	with clamps	LM-10016S		d1=11; d2=46; L [mm]=185
<b>L 300 Box (P0_W, P1_W, P0_V, P1_V, P_2V, P2_W)</b>			<b>11/1986 → 05/2003</b>		
Bellow, steering	2.4 4x4, 2.5 TD, 2.5 TD 4x4	with clamps;	LM-10016S		d1=11; d2=46; L [mm]=185
<b>LANCER Mk III (C1_A, C6_A)</b>			<b>11/1983 → 04/1988</b>		
Dust Cover Kit, shock absorber	1.2 GL, 1.5 GLX, 1.8 Diesel		AK-735022		
Dust Cover Kit, shock absorber	All Models		AK-735086		
Bellow, steering	All Models	with clamps;	LM-10016S		d1=11; d2=46; L [mm]=185
<b>LANCER Mk III Estate (C1_V, C3_V)</b>			<b>09/1985 → 08/1992</b>		
Dust Cover Kit, shock absorber	All Models		AK-735086		
Bellow, steering	1.5, 1.5 12V, 1.8 4x4, 1.8 D	with clamps;	LM-10016S		d1=11; d2=46; L [mm]=185
<b>LANCER Mk IV (C6_A, C7_A)</b>			<b>04/1988 → 05/1994</b>		
Top Strut Mounting	1.3 12V, 1.5 12V, 1.6 16V, 1.8 4x4, 1.8 D, 1.8 GTi 16V		F8-6372		
Bellow, steering	1.3 12V, 1.5, 1.5 12V, 1.6 16V, 1.8 4x4, 1.8 D, 1.8 GTi 16V	with clamps;	LM-10016S		d1=11; d2=46; L [mm]=185
<b>LANCER Mk IV Saloon (C6_A)</b>			<b>04/1988 → 06/1992</b>		
Dust Cover Kit, shock absorber	1.3, 1.3 12V, 1.5, 1.8 GLX Diesel		AK-735023		L=140
Top Strut Mounting	1.3, 1.3 12V, 1.5, 1.5 12V, 1.8 GLX Diesel		F8-6372		
Bellow, steering	1.3, 1.3 12V, 1.5, 1.5 12V, 1.8 GLX Diesel	with clamps;	LM-10016S		d1=11; d2=46; L [mm]=185
<b>LANCER Mk V (CB/D_A)</b>			<b>06/1992 → 12/1996</b>		
Top Strut Mounting	1.3, 1.6, 1.6 16V, 1.6 16V 4WD, 1.8 16V, 1.8 GTi, 2.0 Diesel		F8-6373		
Rod/Strut, wheel suspension	1.3, 1.6, 1.6 16V, 1.6 16V 4WD, 1.8 16V, 1.8 GTi, 2.0 Diesel		F8-6469		L=143

<b>AK-735022</b>	<b>AK-735023</b>	<b>AK-735086</b>	<b>F8-6372</b>	<b>F8-6373</b>	<b>F8-6469</b>	<b>F8-6696</b>
Ref.Nr.:	Ref.Nr.: MB303070	Ref.Nr.:	Ref.Nr.: MB518798	Ref.Nr.: MB808306	Ref.Nr.: 30620785	Ref.Nr.: MR102063
<b>F8-7860</b>	<b>F8-7870</b>	<b>F8-8034</b>	<b>LM-10016S</b>			
Ref.Nr.: MD110165	Ref.Nr.: MD374223	Ref.Nr.: MR150767	Ref.Nr.: MB501711			

Article Description

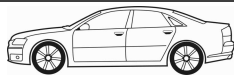

Article Nr.

Fitting Position



<b>LANCER Mk V (CB/D_A)</b>			<b>06/1992 → 12/1996</b>	
Control Arm-/Trailing Arm Bush	1.3 , 1.6 , 1.6 16V , 1.6 16V 4WD , 2.0 Diesel		<b>F8-6696</b>	
Control Arm-/Trailing Arm Bush	1.3 , 1.6 , 1.6 16V , 1.6 16V 4WD , 2.0 Diesel		<b>F8-6772</b>	H=49.5; d=12.2; D1=36.2; D2=34.7
Bellow, steering	1.3 , 1.6 , 1.6 16V , 1.6 16V 4WD , 2.0 Diesel	with clamps;	<b>LM-10016S</b>	d1=11; d2=46; L [mm]=185
<b>LANCER Mk V Estate (CB_W, CD_W)</b>			<b>12/1992 → 10/2003</b>	
Rod/Strut, wheel suspension	1.5, 1.6 16V , 1.6 16V 4WD , 1.8 4x4, 1.8 i, 2.0 D, 2.0 D 4x4		<b>F8-6469</b>	L=143
Control Arm-/Trailing Arm Bush	1.6 16V , 1.6 16V 4WD , 2.0 D		<b>F8-6696</b>	
Control Arm-/Trailing Arm Bush	1.6 16V , 1.6 16V 4WD , 2.0 D		<b>F8-6772</b>	H=49.5; d=12.2; D1=36.2; D2=34.7
Bellow, steering	1.6 16V , 1.6 16V 4WD , 2.0 D	with clamps;	<b>LM-10016S</b>	d1=11; d2=46; L [mm]=185
<b>LANCER Saloon (CY/Z_A)</b>			<b>06/2008 →</b>	
Dust Cover Kit, shock absorber	1.6 Alcohol	<b>ST</b>	<b>AK-735410</b>	H=210
Alternator Freewheel Clutch	2.0 EVO		<b>F5-1022</b>	
Protective Cap/Bellow, shock absorber	1.6 Alcohol		<b>F8-5683</b>	H=210
<b>LANCER Mk VI (CJ-CP_)</b>			<b>09/1995 → 08/2003</b>	
Control Arm-/Trailing Arm Bush	1.3 12V , 1.5 16V , 1.6 16V , 1.8 16V, 2.0 16V EVO		<b>F8-6696</b>	
Control Arm-/Trailing Arm Bush	1.3 12V , 1.5 16V , 1.6 16V , 1.8 16V		<b>F8-6772</b>	H=49.5; d=12.2; D1=36.2; D2=34.7
<b>LANCER Estate (CS_W)</b>			<b>09/2003 → 10/2008</b>	
Dust Cover Kit, shock absorber	All Models		<b>AK-735237</b>	
Control Arm-/Trailing Arm Bush	1.6, 2.0		<b>F8-7129</b>	H=14; d=14; D=60
<b>LANCER Saloon (CS_A, CT0)</b>			<b>08/2003 → 03/2007</b>	
Dust Cover Kit, shock absorber	All Models		<b>AK-735237</b>	
Control Arm-/Trailing Arm Bush	2.0 16V EVO IX , 2.0 16V EVO VIII		<b>F8-6696</b>	
Control Arm-/Trailing Arm Bush	2.0 16V EVO VIII		<b>F8-6772</b>	H=49.5; d=12.2; D1=36.2; D2=34.7
Control Arm-/Trailing Arm Bush	1.3, 1.6 , 2.0		<b>F8-7129</b>	H=14; d=14; D=60
<b>OUTLANDER I (CU_W)</b>			<b>03/2001 → 12/2006</b>	
Dust Cover Kit, shock absorber	All Models		<b>AK-735237</b>	
Control Arm-/Trailing Arm Bush	2.0 , 2.0 4WD , 2.0 Turbo 4WD , 2.4 4WD		<b>F8-7129</b>	H=14; d=14; D=60

<b>AK-735237</b>	<b>AK-735410</b>	<b>F5-1022</b>	<b>F8-5683</b>	<b>F8-6469</b>	<b>F8-6696</b>	<b>F8-6772</b>
Ref.Nr.: MR961189	Ref.Nr.: 1J0412303	Ref.Nr.:	Ref.Nr.: 357413175A	Ref.Nr.: 30620785	Ref.Nr.: MR102063	Ref.Nr.: 30620972
<b>F8-7129</b>	<b>LM-10016S</b>					
Ref.Nr.: MR403441	Ref.Nr.: MB501711					

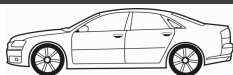
**Article Description****Article Nr.****Fitting Position**

<b>OUTLANDER II (CW_W)</b>				<b>08/2007 → 11/2012</b>	
Alternator Freewheel Clutch	2.4 Mivec 4WD		<b>F5-1022</b>		
Alternator Freewheel Clutch	2.2 DI-D 4WD		<b>F5-1131</b>		
<b>PAJERO/SHOGUN Mk II (V3_W, V2_W, V4_W)</b>				<b>12/1990 → 10/1999</b>	
Belt Pulley, crankshaft	2.5 TD 4x4		<b>F8-7860</b>		Belt Pulley Ø [mm]=173; H1=31; H2=51
Stabiliser Mounting	2.8 D All-wheel Drive, 2.8 TD		<b>F8-8032</b>	⊕ ⊕	d=27
<b>PAJERO/SHOGUN Open Off-Road Vehicle (V2_W, V4_W)</b>				<b>12/1990 → 04/2000</b>	
Belt Pulley, crankshaft	2.5 TD		<b>F8-7860</b>		Belt Pulley Ø [mm]=173; H1=31; H2=51
Stabiliser Mounting	2.5 TD		<b>F8-8032</b>	⊕ ⊕	d=27
<b>PAJERO/SHOGUN Mk III Open Off-Road Vehicle (V6_W, V7_W)</b>				<b>04/2000 → 12/2006</b>	
Belt Pulley, crankshaft	2.5 TDi	07/2001 →	<b>F8-7870</b>		
<b>CHALLENGER (K90)</b>				<b>11/1998 →</b>	
Belt Pulley, crankshaft	2.5 TD		<b>F8-7860</b>		Belt Pulley Ø [mm]=173; H1=31; H2=51
Belt Pulley, crankshaft	2.5 TD	07/2006 →	<b>F8-7860</b>		Belt Pulley Ø [mm]=173; H1=31; H2=51
Belt Pulley, crankshaft	2.5 TD		<b>F8-7870</b>		
Belt Pulley, crankshaft	2.5 TD	07/2001 →	<b>F8-7870</b>		
Stabiliser Mounting	2.5 TD, 3.0 V6		<b>F8-8033</b>	⊕ ⊕	d=28
Stabiliser Mounting	2.5 TD, 3.0 V6		<b>F8-8034</b>	⊕ ⊕	d=20
Stabiliser Mounting	2.5 TD, 3.0 V6		<b>F8-8035</b>	⊕ ⊕	d=21
<b>PAJERO SPORT II (KH_, KG_)</b>				<b>07/2008 →</b>	
Stabiliser Mounting	2.5 DI-D 4x4, 2.5 TD		<b>F8-8035</b>	⊕ ⊕	d=21
<b>SPACE RUNNER (N1_W, N2_W)</b>				<b>10/1991 → 08/1999</b>	
Bellow, steering	1.8, 1.8 4x4	with clamps	<b>LM-10016S</b>		d1=11; d2=46; L [mm]=185
<b>SPACE STAR (DG_A)</b>				<b>06/1998 → 12/2004</b>	
Dust Cover Kit, shock absorber	1.3 16V		<b>AK-735238</b>	⊕ ⊕	
Alternator Freewheel Clutch	1.9 DI-D		<b>F5-1025</b>		
<b>SPACE WAGON (D0_V/W)</b>				<b>01/1984 → 04/1991</b>	
Dust Cover Kit, shock absorber	1.8 4x4, 1.8 GLX, 1.8 TD, 2.0 4x4, 2.0 GLX, 2.0 GLX 4x4, 2.0 GLXi, 2.0 GLXi 4x4		<b>AK-735086</b>	⊕ ⊕	
<b>SPACE WAGON (N3_W, N4_W)</b>				<b>10/1991 → 10/1998</b>	
Bellow, steering	2.4, 2.4 4x4, 2.4 i	with clamps	<b>LM-10016S</b>		d1=11; d2=46; L [mm]=185

<b>AK-735086</b>	<b>AK-735238</b>		<b>F5-1022</b>	<b>F5-1025</b>	<b>F5-1131</b>	<b>F8-7860</b>	<b>F8-7870</b>
Ref.Nr.:	Ref.Nr.: MR316540		Ref.Nr.:	Ref.Nr.: 23151-00Q0B	Ref.Nr.:	Ref.Nr.: MD110165	Ref.Nr.: MD374223
<b>F8-8032</b>	<b>F8-8033</b>	<b>F8-8034</b>	<b>F8-8035</b>	<b>LM-10016S</b>			
Ref.Nr.: MR150092	Ref.Nr.: MR267649	Ref.Nr.: MR150767	Ref.Nr.: MB338594	Ref.Nr.: MB501711			

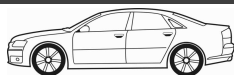

Article Description



Article Nr.

Fitting Position



<b>TREDIA (A21_)</b>		<b>09/1982 → 10/1987</b>	
Dust Cover Kit, shock absorber	1.4 GLX , 1.6 Turbo , 1.8 GLS , 1.8 Turbo, GLS 1.6	<b>AK-735086</b>	 
Bellow, steering	1.4 GLX , 1.6 Turbo , 1.8 GLS , 1.8 Turbo, GLS 1.6	<b>LM-10016S</b>	 d1=11; d2=46; L [mm]=185



**AK-735086**

Ref.Nr.:



**LM-10016S**

Ref.Nr.: MB501711

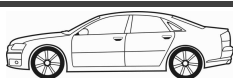

**Article Description****Article Nr.****Fitting Position**

<b>100 NX (B13)</b>			<b>03/1990 → 10/1994</b>	
Dust Cover Kit, shock absorber	1.6, 1.6 SR, 2.0 GTI		AK-735114	
Top Strut Mounting	All Models		F8-5945	
<b>SILVIA Coupe (S14)</b>			<b>10/1993 → 12/1999</b>	
Top Strut Mounting	2.0 i 16V, 2.0 i 16V Turbo		F8-5945	
Repair Kit, suspension strut	2.0 i 16V, 2.0 i 16V Turbo		F8-5947	
<b>ALMERA (N15)</b>			<b>07/1995 → 07/2000</b>	
Dust Cover Kit, shock absorber	1.4, 1.4 GX,LX, 1.6, 1.6 SLX, 2.0 D		AK-735242	
Dust Cover Kit, shock absorber	1.4, 1.4 GX,LX, 1.6, 1.6 SLX, 2.0 D		AK-735243	
Top Strut Mounting	All Models		F8-5945	
Repair Kit, suspension strut	1.4, 1.4 GX,LX, 1.6, 1.6 SLX, 2.0 D		F8-5947	
<b>ALMERA Hatchback (N15)</b>			<b>07/1995 → 03/2000</b>	
Dust Cover Kit, shock absorber	1.4, 1.4 S,GX,LX, 1.6, 1.6 SR,SLX, 2.0 D, 2.0 GTi		AK-735242	
Dust Cover Kit, shock absorber	1.4, 1.4 S,GX,LX, 1.6, 1.6 SR,SLX, 2.0 D, 2.0 GTi		AK-735243	
Top Strut Mounting	All Models		F8-5945	
Repair Kit, suspension strut	1.4, 1.4 S,GX,LX, 1.5, 1.6, 1.6 SR,SLX, 2.0 D		F8-5947	
<b>ALMERA Mk II (N16)</b>			<b>07/2000 →</b>	
Dust Cover Kit, shock absorber	1.5, 1.5 dCi, 1.5 XL, 1.8, 2.2 dCi, 2.2 Di		AK-735244	
Dust Cover Kit, shock absorber	1.5, 1.5 dCi, 1.5 XL, 1.8, 2.2 dCi, 2.2 Di		AK-735245	
Alternator Freewheel Clutch	1.5 dCi		F5-1061	
Top Strut Mounting	1.5, 1.5 dCi, 1.8, 2.2 dCi, 2.2 Di		F8-7465	
Top Strut Mounting	1.5, 1.5 dCi, 1.8, 2.2 dCi, 2.2 Di		F8-7466	
Engine Mounting	1.5, 1.8		F8-8176	
<b>ALMERA Mk II (N16)</b>			<b>01/2000 →</b>	
Dust Cover Kit, shock absorber	1.5, 1.5 dCi, 1.5 XL, 1.8, 2.2 dCi, 2.2 Di		AK-735244	
Dust Cover Kit, shock absorber	1.5, 1.5 dCi, 1.5 XL, 1.8, 2.2 dCi, 2.2 Di		AK-735245	
Alternator Freewheel Clutch	1.5 dCi		F5-1061	
Top Strut Mounting	1.5, 1.5 dCi, 1.8, 2.2 dCi, 2.2 Di		F8-7465	
Top Strut Mounting	1.5, 1.5 dCi, 1.8, 2.2 dCi, 2.2 Di		F8-7466	
Engine Mounting	1.5, 1.8		F8-8176	
<b>ALMERA TINO (V10)</b>			<b>08/2000 →</b>	
Dust Cover Kit, shock absorber	All Models		AK-735245	
Dust Cover Kit, shock absorber	All Models		AK-735246	
Top Strut Mounting	All Models		F8-7371	
Top Strut Mounting	All Models		F8-7466	

<b>AK-735114</b>	<b>AK-735242</b>	<b>AK-735243</b>	<b>AK-735244</b>	<b>AK-735245</b>	<b>AK-735246</b>	<b>F5-1061</b>
Ref.Nr.:	Ref.Nr.: 540520M011	Ref.Nr.: 552400M315	Ref.Nr.: 540524M400	Ref.Nr.: 552404U000	Ref.Nr.: 5405031U02	Ref.Nr.: 7700110616
<b>F8-5945</b>	<b>F8-5947</b>	<b>F8-7371</b>	<b>F8-7465</b>	<b>F8-7466</b>	<b>F8-8176</b>	
Ref.Nr.: 5432050Y12	Ref.Nr.: 5621861L10	Ref.Nr.: 54320-8H310	Ref.Nr.: 54320BM400	Ref.Nr.: 55320BM400	Ref.Nr.: 11320BM500	

Article Description



Article Nr.

Fitting Position



Article Description			Article Nr.	Fitting Position	
<b>ALTIMA</b>					10/2006 →
Alternator Freewheel Clutch	2.5		F5-1071		
Alternator Freewheel Clutch	2.5		F5-1116		
<b>ALTIMA Coupe</b>					10/2006 →
Alternator Freewheel Clutch	All Models		F5-1116		
<b>AVENIR</b>					09/2001 →
Alternator Freewheel Clutch	2.0, 2.0 4x4		F5-1071		
<b>BASSARA</b>					06/2002 → 08/2003
Alternator Freewheel Clutch	2.5		F5-1071		
<b>BLUEBIRD (910)</b>					01/1980 → 12/1983
Dust Cover Kit, shock absorber	1.8, 2.0 D, 2.0 i		AK-735114		
<b>BLUEBIRD Traveller (W910)</b>					01/1980 → 05/1984
Dust Cover Kit, shock absorber	1.8, 2.0 D		AK-735114		
<b>BLUEBIRD (U11)</b>					11/1983 → 05/1990
Dust Cover Kit, shock absorber	1.8, 1.8 Turbo, 2.0 D, 2.0 i		AK-735114		
<b>BLUEBIRD Station Wagon (WU11)</b>					04/1984 → 12/1990
Dust Cover Kit, shock absorber	2.0, 2.0 D, 2.0 i		AK-735114		
<b>BLUEBIRD (T72, T12)</b>					12/1985 → 12/1990
Dust Cover Kit, shock absorber	1.6, 1.8 i 16V, 1.8 Turbo, 2.0, 2.0 D, 2.0 i		AK-735114		
<b>BLUEBIRD Hatchback (T72, T12)</b>					12/1985 → 11/1992
Dust Cover Kit, shock absorber	1.6, 1.8 i 16V, 1.8 Turbo, 2.0, 2.0 D, 2.0 i		AK-735114		
<b>CHERRY III (N12)</b>					05/1982 → 12/1986
Dust Cover Kit, shock absorber	1.0, 1.3, 1.5, 1.7 D		AK-735088		
<b>CUBE (Z12)</b>					03/2010 →
Alternator Freewheel Clutch	1.5 dCi		F5-1122		
Anti-Friction Bearing	1.5 dCi, 1.6 16V		F8-7152		
<b>DATSUN 180 B (PL810)</b>					05/1977 → 01/1981
Top Strut Mounting	1.8		F8-4100		
<b>INTERSTAR Bus (X70)</b>					07/2002 →
Alternator Freewheel Clutch	dCi 100, dCi 120, dCi 150, dCi 80, dCi 90		F5-1025		
Alternator Freewheel Clutch	dCi 140		F5-1035		
Alternator Freewheel Clutch	dCi 80		F5-1036		
Alternator Freewheel Clutch	dCi 100, dCi 120, dCi 90		F5-1063		

<b>AK-735088</b>	<b>AK-735114</b>	<b>F5-1025</b>	<b>F5-1035</b>	<b>F5-1036</b>	<b>F5-1063</b>	<b>F5-1071</b>
Ref.Nr.: 60585431	Ref.Nr.:	Ref.Nr.: 23151-00Q0B	Ref.Nr.: 23150-2W200	Ref.Nr.: 23151-00Q0A	Ref.Nr.:	Ref.Nr.: 23151-6N20B
<b>F5-1116</b>	<b>F5-1122</b>	<b>F8-4100</b>	<b>F8-6673</b>	<b>F8-7152</b>		
Ref.Nr.: 265031900	Ref.Nr.:	Ref.Nr.: 344511	Ref.Nr.: 54570-00QAA	Ref.Nr.: 54325-AX000		

**Article Description****Article Nr.****Fitting Position**

<b>INTERSTAR Bus (X70)</b>		<b>07/2002 →</b>	
Control Arm-/Trailing Arm Bush	All Models	<b>F8-6673</b>	⊕ ⊕ ↓ H=74; d=28; D=55,2
Control Arm-/Trailing Arm Bush	All Models	<b>F8-6674</b>	⊕ ⊕ ↓ H=79; d=28; D=55,5
Control Arm-/Trailing Arm Bush	dCi 100, dCi 120, dCi 140, dCi 80, dCi 90	<b>F8-6687</b>	⊕ ⊕ ↑
Bellow, steering	All Models	<b>LM-10032S</b>	d1=9.5; d2=42; L [mm]=165
<b>INTERSTAR Box (X70)</b>		<b>07/2002 →</b>	
Alternator Freewheel Clutch	dCi 100, dCi 120, dCi 150, dCi 80, dCi 90	<b>F5-1025</b>	
Alternator Freewheel Clutch	dCi 140	<b>F5-1035</b>	
Alternator Freewheel Clutch	dCi 80	<b>F5-1036</b>	
Alternator Freewheel Clutch	dCi 100, dCi 120, dCi 90	<b>F5-1063</b>	
Control Arm-/Trailing Arm Bush	All Models	<b>F8-6673</b>	⊕ ⊕ ↓ H=74; d=28; D=55,2
Control Arm-/Trailing Arm Bush	All Models	<b>F8-6674</b>	⊕ ⊕ ↓ H=79; d=28; D=55,5
Control Arm-/Trailing Arm Bush	dCi 100, dCi 120, dCi 140, dCi 80	<b>F8-6687</b>	⊕ ⊕ ↑
Bellow, steering	All Models	<b>LM-10032S</b>	d1=9.5; d2=42; L [mm]=165
<b>INTERSTAR Platform/Chassis</b>		<b>08/2003 →</b>	
Alternator Freewheel Clutch	dCi 100, dCi 120, dCi 150	<b>F5-1025</b>	
Alternator Freewheel Clutch	dCi 140	<b>F5-1035</b>	
Alternator Freewheel Clutch	dCi 100, dCi 120	<b>F5-1063</b>	
Control Arm-/Trailing Arm Bush	dCi 120, dCi 140	<b>F8-6673</b>	⊕ ⊕ ↓ H=74; d=28; D=55,2
Control Arm-/Trailing Arm Bush	All Models	<b>F8-6674</b>	⊕ ⊕ ↓ H=79; d=28; D=55,5
Control Arm-/Trailing Arm Bush	dCi 100, dCi 120, dCi 140	<b>F8-6687</b>	⊕ ⊕ ↑
Bellow, steering	All Models	<b>LM-10032S</b>	d1=9.5; d2=42; L [mm]=165
<b>JUKE (F15)</b>		<b>06/2010 →</b>	
Alternator Freewheel Clutch	1.5 dCi	<b>F5-1122</b>	
Alternator Freewheel Clutch	1.6 DIG-T, 1.6 DIG-T 4x4	<b>F5-1127</b>	
Alternator Freewheel Clutch	1.5 dCi	<b>F5-1130</b>	05/2013 →
<b>KUBISTAR (X76)</b>		<b>08/2003 → 10/2009</b>	
Dust Cover Kit, shock absorber	1.2, 1.2 16V, 1.5 dCi, 1.5 dCi 70, 1.5 dCi 85, 1.6 16V	<b>AK-735257</b>	⊕ ⊕
Alternator Freewheel Clutch	1.5 dCi, 1.5 dCi 70, 1.5 dCi 85, 1.6 16V	<b>F5-1061</b>	
Stabiliser Set	1.2 16V, 1.5 dCi	<b>F8-5087</b>	

<b>AK-735257</b>	<b>F5-1025</b>	<b>F5-1035</b>	<b>F5-1036</b>	<b>F5-1061</b>	<b>F5-1063</b>	<b>F5-1122</b>
Ref.Nr.: 7700802667	Ref.Nr.: 23151-00Q0B	Ref.Nr.: 23150-2W200	Ref.Nr.: 23151-00Q0A	Ref.Nr.: 7700110616	Ref.Nr.:	Ref.Nr.:
<b>F5-1127</b>	<b>F5-1130</b>	<b>F8-5087</b>	<b>F8-5496</b>	<b>F8-6673</b>	<b>F8-6674</b>	<b>F8-6687</b>
Ref.Nr.: 23151-EL010	Ref.Nr.: 23151-3VD1A	Ref.Nr.: 54616-00QAA	Ref.Nr.: 7700829529	Ref.Nr.: 54570-00QAA	Ref.Nr.: 4500095	Ref.Nr.: 4500091
<b>LM-10032S</b>						
Ref.Nr.: 7701470361						

Article Description



Article Nr.

Fitting Position



<b>KUBISTAR (X76)</b>		08/2003 → 10/2009	
Top Strut Mounting	1.2, 1.2 16V, 1.5 dCi, 1.5 dCi 70, 1.5 dCi 85, 1.6 16V	F8-5496	
Top Strut Mounting	1.2, 1.5 dCi, 1.6 16V	F8-6329	
Engine Mounting	1.2, 1.2 16V, 1.6 16V	F8-8188	
<b>KUBISTAR Box (X80)</b>		08/2003 →	
Alternator Freewheel Clutch	1.5 dCi, 1.6 16V	F5-1061	
Top Strut Mounting	1.2, 1.2 16V, 1.5 dCi, 1.6 16V	F8-5496	
Engine Mounting	1.2, 1.2 16V, 1.6 16V	F8-8188	
<b>MAXIMA QX (A32)</b>		01/1995 → 08/2000	
Top Strut Mounting	All Models	F8-5946	
Repair Kit, suspension strut	All Models	F8-5947	
<b>MAXIMA QX (A33)</b>		03/2000 → 11/2003	
Top Strut Mounting	2.0 V6 24V, 3.0 V6 24V	F8-7371	
<b>MICRA I (K10)</b>		12/1982 → 07/1992	
Dust Cover Kit, shock absorber	All Models	AK-735111	
Control Arm-/Trailing Arm Bush	All Models	F8-5246	
Control Arm-/Trailing Arm Bush	All Models	F8-5247	H=47; d=12; D=27
<b>MICRA II (K11)</b>		08/1992 → 02/2003	
Dust Cover Kit, shock absorber	1.0 i 16V, 1.3 i 16V, 1.4 i 16V, 1.5 D	AK-735239	
<b>MICRA III (K12)</b>		01/2003 → 06/2010	
Dust Cover Kit, shock absorber	All Models	AK-735240	
Dust Cover Kit, shock absorber	All Models	AK-735241	
Alternator Freewheel Clutch	1.5 dCi	F5-1061	
Alternator Freewheel Clutch	1.5 dCi	F5-1062	
Alternator Freewheel Clutch	1.5 dCi	F5-1122	
Belt Pulley, crankshaft	1.5 dCi	F8-5657	
Top Strut Mounting	All Models	F8-6338	
Control Arm-/Trailing Arm Bush	1.0 16V, 1.2 16V, 1.4 16V, 1.5 dCi, 160 SR	F8-6523	d=12; D=40; Thick. [mm]=55
Control Arm-/Trailing Arm Bush	1.2 16V	F8-6523	d=12; D=40; Thick. [mm]=55
Top Strut Mounting	All Models	F8-6525	
Top Strut Mounting	All Models	F8-6526	
Control Arm-/Trailing Arm Bush	All Models	F8-6662	H=53; d=12; D=58

<b>AK-735111</b>	<b>AK-735239</b>	<b>AK-735240</b>	<b>AK-735241</b>	<b>F5-1061</b>	<b>F5-1062</b>	<b>F5-1122</b>
Ref.Nr.:	Ref.Nr.: 540505F110	Ref.Nr.: 54050AX601	Ref.Nr.: 55240AX600	Ref.Nr.: 7700110616	Ref.Nr.: 7701476465	Ref.Nr.:
<b>F8-5246</b>	<b>F8-5247</b>	<b>F8-5496</b>	<b>F8-5657</b>	<b>F8-5946</b>	<b>F8-5947</b>	<b>F8-6329</b>
Ref.Nr.: 5447601B00	Ref.Nr.: 5453501B00	Ref.Nr.: 7700829529	Ref.Nr.: 8200185800	Ref.Nr.: 54320-40U00	Ref.Nr.: 5621861L10	Ref.Nr.: 7700829529
<b>F8-6338</b>	<b>F8-6523</b>	<b>F8-6525</b>	<b>F8-6526</b>	<b>F8-6662</b>	<b>F8-7057</b>	<b>F8-7371</b>
Ref.Nr.: 54325-AX000	Ref.Nr.: 54500-BC42A	Ref.Nr.: 54320-AX600	Ref.Nr.: 8200504291	Ref.Nr.: 82 00 346 942	Ref.Nr.: 54320AX600	Ref.Nr.: 54320-8H310

**Article Description****Article Nr.****Fitting Position**

<b>MICRA III (K12)</b>			<b>01/2003 → 06/2010</b>		
Top Strut Mounting	1.0 16V, 1.2 16V, 1.4 16V, 1.5 dCi, 160 SR		<b>F8-7057</b>		
Anti-Friction Bearing	All Models		<b>F8-7152</b>		
Belt Pulley, crankshaft	1.5 dCi	Number of Ribs: 5; Parameter: 6PK	<b>F8-7732</b>		
<b>MICRA C+C (K12)</b>			<b>08/2005 →</b>		
Dust Cover Kit, shock absorber	All Models		<b>AK-735240</b>		
Dust Cover Kit, shock absorber	All Models		<b>AK-735241</b>		
Top Strut Mounting	All Models		<b>F8-6338</b>		
Control Arm-/Trailing Arm Bush	All Models		<b>F8-6523</b>		d=12; D=40; Thick. [mm]=55
Top Strut Mounting	All Models		<b>F8-6525</b>		
Top Strut Mounting	All Models		<b>F8-6526</b>		
Control Arm-/Trailing Arm Bush	All Models		<b>F8-6662</b>		H=53; d=12; D=58
Top Strut Mounting	All Models		<b>F8-7057</b>		
Anti-Friction Bearing	All Models		<b>F8-7152</b>		
<b>MICRA IV (K13)</b>			<b>04/2011 →</b>		
Alternator Freewheel Clutch	1.2 DIG		<b>F5-1082</b>		
<b>MURANO (Z50)</b>			<b>08/2003 →</b>		
Top Strut Mounting	3.5 4x4		<b>F8-7371</b>		
<b>MURANO (Z51)</b>			<b>01/2010 →</b>		
Alternator Freewheel Clutch	2.5 4x4		<b>F5-1092</b>		
Alternator Freewheel Clutch	2.5 4x4		<b>F5-1150</b>		
<b>NAVARA (D40)</b>			<b>07/2005 →</b>		
Alternator Freewheel Clutch	2.5 dCi, 2.5 dCi 4WD		<b>F5-1092</b>		
Alternator Freewheel Clutch	2.5 dCi, 2.5 dCi 4WD		<b>F5-1150</b>		
<b>NAVARA Platform/Chassis (D40)</b>			<b>08/2008 →</b>		
Alternator Freewheel Clutch	2.5 dCi, 2.5 dCi 4WD		<b>F5-1092</b>		
Alternator Freewheel Clutch	2.5 dCi, 2.5 dCi 4WD		<b>F5-1150</b>		
<b>NOTE (E11)</b>			<b>03/2006 →</b>		
Dust Cover Kit, shock absorber	1.4, 1.5 dCi, 1.6		<b>AK-735240</b>		
Alternator Freewheel Clutch	1.5 dCi		<b>F5-1061</b>		
Alternator Freewheel Clutch	1.5 dCi		<b>F5-1122</b>		
Control Arm-/Trailing Arm Bush	1.4, 1.5 dCi, 1.6		<b>F8-6523</b>		d=12; D=40; Thick. [mm]=55

<b>AK-735240</b>	<b>AK-735241</b>	<b>F5-1061</b>	<b>F5-1082</b>	<b>F5-1092</b>	<b>F5-1122</b>	<b>F5-1150</b>
Ref.Nr.: 54050AX601	Ref.Nr.: 55240AX600	Ref.Nr.: 7700110616	Ref.Nr.: LW18-18-W11	Ref.Nr.: 23151EB301	Ref.Nr.:	Ref.Nr.: 23151-EB301
<b>F8-6338</b>	<b>F8-6523</b>	<b>F8-6525</b>	<b>F8-6526</b>	<b>F8-6662</b>	<b>F8-7057</b>	<b>F8-7152</b>
Ref.Nr.: 54325-AX000	Ref.Nr.: 54500-BC42A	Ref.Nr.: 54320-AX600	Ref.Nr.: 8200504291	Ref.Nr.: 82 00 346 942	Ref.Nr.: 54320AX600	Ref.Nr.: 54325-AX000
<b>F8-7371</b>	<b>F8-7732</b>					
Ref.Nr.: 54320-8H310	Ref.Nr.: 8200477938					

Article Description



Article Nr.

Fitting Position



<b>NOTE (E11)</b>		<b>03/2006 →</b>	
Control Arm-/Trailing Arm Bush	1.4, 1.5 dCi, 1.6	F8-6662	H=53; d=12; D=58
Anti-Friction Bearing	1.4, 1.5 dCi, 1.6	F8-7152	
<b>NV200 / EVALIA Bus</b>		<b>07/2010 →</b>	
Alternator Freewheel Clutch	1.5 dci	F5-1061	
Alternator Freewheel Clutch	1.5 dci	F5-1122	
<b>NV200 Box</b>		<b>02/2010 →</b>	
Alternator Freewheel Clutch	1.5 dci	F5-1061	
Alternator Freewheel Clutch	1.5 dci	F5-1122	
<b>NV400 Bus</b>		<b>11/2011 →</b>	
Alternator Freewheel Clutch	2.3 dCi	F5-1129	
<b>NV400 Box</b>		<b>11/2011 →</b>	
Alternator Freewheel Clutch	2.3 dCi, 2.3 dCi [RWD]	F5-1129	
<b>NV400 Platform/Chassis</b>		<b>11/2011 →</b>	
Alternator Freewheel Clutch	2.3 dCi, 2.3 dCi [RWD]	F5-1129	
<b>PATHFINDER III (R51)</b>		<b>01/2005 →</b>	
Alternator Freewheel Clutch	2.5 dCi, 2.5 dCi 4WD	F5-1092	
Alternator Freewheel Clutch	2.5 dCi, 2.5 dCi 4WD	F5-1150	
<b>PATROL GR Mk II Closed Off-Road Vehicle (Y61)</b>		<b>05/2000 → 09/2004</b>	
Alternator Freewheel Clutch	3.0 D, 3.0 D All-wheel Drive, 3.0 DTi	F5-1035	
<b>PATROL V Platform/Chassis</b>		<b>09/2007 →</b>	
Alternator Freewheel Clutch	All Models	F5-1035	
<b>PICK UP III (D22)</b>		<b>03/2002 →</b>	
Alternator Freewheel Clutch	2.5 Di, 2.5 Di 4WD	F5-1092	
Alternator Freewheel Clutch	2.5 Di, 2.5 Di 4WD	F5-1150	
<b>PRIMASTAR Van (X83)</b>		<b>03/2001 →</b>	
Alternator Freewheel Clutch	2.0, dCi 100, dCi 140, dCi 150, dCi 80	F5-1025	
Alternator Freewheel Clutch	2.0, dCi 100, dCi 80	F5-1036	
Alternator Freewheel Clutch	dCi 150	F5-1063	
Alternator Freewheel Clutch	dCi 120, dCi 90	F5-1110	
Top Strut Mounting	2.0, dCi 100, dCi 120, dCi 140, dCi 150, dCi 80, dCi 90	F8-6196	
Top Strut Mounting	2.0, dCi 100, dCi 120, dCi 140, dCi 150, dCi 80, dCi 90	F8-6197	
Bellow Set, steering	2.0, dCi 100, dCi 120, dCi 140, dCi 150, dCi 80, dCi 90	F8-6478	d1=13; d2=54,5; L [mm]=215
Mounting, axle beam	2.0, dCi 100, dCi 120, dCi 140, dCi 150, dCi 80, dCi 90	F8-6661	



**Article Description****Article Nr.****Fitting Position**

<b>PRIMASTAR Van (X83)</b>				<b>03/2001 →</b>	
Engine Mounting	2.0, dCi 100, dCi 80		<b>F8-6690</b>	⊕	
Engine Mounting	2.0, dCi 100, dCi 80		<b>F8-6691</b>	⊕	
Engine Mounting	dCi 120, dCi 90	not for  M9R630, M9R692	<b>F8-6691</b>	⊕	
Engine Mounting	2.0, dCi 100, dCi 80		<b>F8-6692</b>	↑	
Engine Mounting	2.0, dCi 100, dCi 80		<b>F8-6693</b>	↓	
Anti-Friction Bearing	2.0, dCi 100, dCi 120, dCi 140, dCi 150, dCi 80, dCi 90		<b>F8-7151</b>		H1=15; H2=12; d=16; D=52
Engine Mounting	dCi 115, dCi 120, dCi 140, dCi 150, dCi 90		<b>F8-7733</b>	⊕	
Engine Mounting	dCi 115, dCi 120, dCi 140, dCi 150, dCi 90		<b>F8-7736</b>	↓	
Engine Mounting	dCi 120, dCi 90		<b>F8-7737</b>	⊕ ↑	
Control Arm-Trailing Arm Bush	2.0, dCi 100, dCi 120, dCi 140, dCi 150, dCi 80, dCi 90		<b>F8-7988</b>	⊕ ⊕	
<b>PRIMASTAR Box (X83)</b>				<b>09/2002 →</b>	
Alternator Freewheel Clutch	2.0, dCi 100, dCi 140, dCi 150, dCi 80		<b>F5-1025</b>		
Alternator Freewheel Clutch	2.0, dCi 100, dCi 80		<b>F5-1036</b>		
Alternator Freewheel Clutch	dCi 150		<b>F5-1063</b>		
Alternator Freewheel Clutch	dCi 120, dCi 90		<b>F5-1110</b>		
Top Strut Mounting	2.0, dCi 100, dCi 120, dCi 140, dCi 150, dCi 80, dCi 90		<b>F8-6196</b>	⊕ ⊕	
Top Strut Mounting	2.0, dCi 100, dCi 120, dCi 140, dCi 150, dCi 80, dCi 90		<b>F8-6197</b>	⊕ ⊕	
Bellow Set, steering	2.0, dCi 100, dCi 120, dCi 140, dCi 150, dCi 80, dCi 90	with clamps	<b>F8-6478</b>	⊕ ⊕ ⊕	d1=13; d2=54,5; L [mm]=215
Mounting, axle beam	2.0, dCi 100, dCi 140, dCi 150, dCi 80, dCi 90		<b>F8-6661</b>	⊕ ⊕	
Engine Mounting	2.0, dCi 100, dCi 80		<b>F8-6690</b>	⊕	
Engine Mounting	2.0, dCi 100, dCi 80		<b>F8-6691</b>	⊕	
Engine Mounting	dCi 120, dCi 90	not for  M9R630, M9R692	<b>F8-6691</b>	⊕	
Engine Mounting	2.0, dCi 100, dCi 80		<b>F8-6692</b>	↑	
Engine Mounting	2.0, dCi 100, dCi 80		<b>F8-6693</b>	↓	
Anti-Friction Bearing	2.0, dCi 100, dCi 120, dCi 140, dCi 150, dCi 80, dCi 90		<b>F8-7151</b>		H1=15; H2=12; d=16; D=52
Engine Mounting	dCi 115, dCi 120, dCi 140, dCi 150, dCi 90		<b>F8-7733</b>	⊕	
Engine Mounting	dCi 115, dCi 120, dCi 140, dCi 150, dCi 90		<b>F8-7736</b>	↓	
Engine Mounting	dCi 120, dCi 90		<b>F8-7737</b>	⊕ ↑	
Control Arm-Trailing Arm Bush	2.0, dCi 100, dCi 120, dCi 140, dCi 150, dCi 80, dCi 90		<b>F8-7988</b>	⊕ ⊕	
<b>PRIMERA (P10)</b>				<b>06/1990 → 06/1996</b>	
Dust Cover Kit, shock absorber	1.6, 2.0 16V, 2.0 D, 2.0 GT		<b>AK-735036</b>	⊕ ⊕	
Dust Cover Kit, shock absorber	1.6, 2.0 16V, 2.0 16V 4x4, 2.0 D, 2.0 GT, 2.0 i		<b>AK-735117</b>	⊕ ⊕	
Engine Mounting	2.0, 2.0 16V, 2.0 16V 4x4, 2.0 GT, 2.0 GT 4x4, 2.0 i		<b>F8-6822</b>	⊕	

<b>AK-735036</b>	<b>AK-735117</b>	<b>F5-1025</b>	<b>F5-1036</b>	<b>F5-1063</b>	<b>F5-1110</b>	<b>F8-6196</b>
Ref.Nr.:	Ref.Nr.:	Ref.Nr.: 23151-00Q0B	Ref.Nr.: 23151-00Q0A	Ref.Nr.:	Ref.Nr.: 8200489514	Ref.Nr.: 54320-00QAA
<b>F8-6197</b>	<b>F8-6478</b>	<b>F8-6661</b>	<b>F8-6690</b>	<b>F8-6691</b>	<b>F8-6692</b>	<b>F8-6693</b>
Ref.Nr.: 7701207491SK	Ref.Nr.: 48203-00QAE	Ref.Nr.: 4412907	Ref.Nr.: 11323-00QAA	Ref.Nr.: 11246-00QAB	Ref.Nr.: 11356-00QAA	Ref.Nr.: 11238-00QAA
<b>F8-6822</b>	<b>F8-7151</b>	<b>F8-7733</b>	<b>F8-7736</b>	<b>F8-7737</b>	<b>F8-7988</b>	<b>LM-10048S</b>
Ref.Nr.: 1122093J20	Ref.Nr.: 4408056	Ref.Nr.: 11323-00QAB	Ref.Nr.: 4411938	Ref.Nr.: 93853920	Ref.Nr.: 8200002869	Ref.Nr.: 48203-Q9025

Article Description



Article Nr.

Fitting Position



				<b>06/1990 → 06/1996</b>	
<b>PRIMERA (P10)</b>					
Bellow, steering	1.6, 2.0 16V, 2.0 16V 4x4, 2.0 D, 2.0 GT	01/1992 →; with clamps	LM-10048S		d1=12; d2=47; L [mm]=190
Bellow, steering	1.6, 2.0, 2.0 GT 4x4, 2.0 i	with clamps	LM-10048S		d1=12; d2=47; L [mm]=190
<b>PRIMERA Hatchback (P10)</b>					
<b>06/1990 → 06/1996</b>					
Dust Cover Kit, shock absorber	1.6, 2.0 16V		AK-735036		
Dust Cover Kit, shock absorber	1.6, 2.0 16V, 2.0 16V 4x4, 2.0 D, 2.0 i		AK-735117		
Engine Mounting	2.0, 2.0 16V, 2.0 16V 4x4, 2.0 GT 4x4, 2.0 i		F8-6822		
Bellow, steering	1.6, 2.0 16V, 2.0 16V 4x4, 2.0 D	01/1992 →; with clamps	LM-10048S		d1=12; d2=47; L [mm]=190
Bellow, steering	1.6, 2.0, 2.0 GT 4x4, 2.0 i	with clamps	LM-10048S		d1=12; d2=47; L [mm]=190
<b>PRIMERA (P11)</b>					
<b>06/1996 → 12/2001</b>					
Dust Cover Kit, shock absorber	1.6 16V, 1.8 16V, 2.0 16V, 2.0 TD		AK-735117		
Engine Mounting	2.0 TD		F8-6827		
Bellow, steering	All Models	with clamps	LM-10048S		d1=12; d2=47; L [mm]=190
<b>PRIMERA Hatchback (P11)</b>					
<b>09/1996 → 07/2002</b>					
Dust Cover Kit, shock absorber	All Models		AK-735117		
Engine Mounting	2.0 TD		F8-6827		
Bellow, steering	All Models	with clamps	LM-10048S		d1=12; d2=47; L [mm]=190
<b>PRIMERA Traveller (WP11)</b>					
<b>06/1996 → 12/2001</b>					
Dust Cover Kit, shock absorber	1.6 16V, 1.8 16V, 2.0 16V, 2.0 TD		AK-735011		
Dust Cover Kit, shock absorber	1.6 16V, 1.8 16V, 2.0 16V, 2.0 TD		AK-735117		
Engine Mounting	2.0 TD		F8-6827		
<b>PRIMERA (P12)</b>					
<b>01/2002 →</b>					
Dust Cover Kit, shock absorber	All Models		AK-735245		
Dust Cover Kit, shock absorber	All Models		AK-735442		
Alternator Freewheel Clutch	2.0, 2.5		F5-1071		
Alternator Freewheel Clutch	2.5		F5-1116		
Belt Pulley, crankshaft	1.9 dCi		F8-7093S1		
Top Strut Mounting	1.6, 1.8, 1.9 dCi, 2.0, 2.2 dCi, 2.2 Di		F8-7371		
Top Strut Mounting	All Models		F8-7466		
<b>PRIMERA Hatchback (P12)</b>					
<b>01/2002 →</b>					
Dust Cover Kit, shock absorber	All Models		AK-735245		
Dust Cover Kit, shock absorber	All Models		AK-735442		
Alternator Freewheel Clutch	2.0, 2.5		F5-1071		
Alternator Freewheel Clutch	2.5		F5-1116		
Top Strut Mounting	1.6, 1.8, 1.9 dCi, 2.0, 2.2 dCi, 2.2 Di		F8-7371		

<b>AK-735011</b>	<b>AK-735036</b>	<b>AK-735117</b>	<b>AK-735245</b>	<b>AK-735442</b>	<b>F5-1071</b>	<b>F5-1116</b>
Ref.Nr.:	Ref.Nr.:	Ref.Nr.:	Ref.Nr.: 552404U000	Ref.Nr.: 540502Y001	Ref.Nr.: 23151-6N20B	Ref.Nr.: 265031900
<b>F8-6822</b>	<b>F8-6827</b>	<b>F8-7093S1</b>	<b>F8-7371</b>	<b>F8-7466</b>	<b>LM-10048S</b>	
Ref.Nr.: 1122093J20	Ref.Nr.: 112202F601	Ref.Nr.: 12303AW300	Ref.Nr.: 54320-8H310	Ref.Nr.: 55320BM400	Ref.Nr.: 48203-Q9025	



**Article Description****Article Nr.****Fitting Position**

<b>PRIMERA Hatchback (P12)</b>			<b>01/2002 →</b>	
Top Strut Mounting	All Models		F8-7466	
<b>PRIMERA Estate (WP12)</b>			<b>01/2002 →</b>	
Dust Cover Kit, shock absorber	All Models		AK-735245	
Dust Cover Kit, shock absorber	All Models		AK-735442	
Alternator Freewheel Clutch	2.0		F5-1071	
Top Strut Mounting	1.6 Visia, 1.8, 1.9 dCi, 2.0, 2.2 dCi, 2.2 Di		F8-7371	
Top Strut Mounting	1.6 Visia, 1.8, 1.9 dCi, 2.0, 2.2 dCi, 2.2 Di		F8-7466	
<b>QASHQAI / QASHQAI +2 (J10, JJ10)</b>			<b>02/2007 →</b>	
Dust Cover Kit, shock absorber	1.5 dCi, 1.6, 2.0, 2.0 All-wheel Drive, 2.0 dCi, 2.0 dCi All-wheel Drive	ST	AK-735436	
Alternator Freewheel Clutch	2.0 dCi, 2.0 dCi All-wheel Drive		F5-1110	
Alternator Freewheel Clutch	1.5 dCi		F5-1122	
Alternator Freewheel Clutch	2.0, 2.0 All-wheel Drive		F5-1127	
Alternator Freewheel Clutch	1.6 dCi, 1.6 dCi All-wheel Drive, 2.0 dCi, 2.0 dCi All-wheel Drive		F5-1129	
Anti-Friction Bearing	1.5 dCi, 1.6, 2.0, 2.0 All-wheel Drive, 2.0 dCi, 2.0 dCi All-wheel Drive		F8-7152	
Belt Pulley, crankshaft	2.0 dCi, 2.0 dCi All-wheel Drive	Number of Ribs: 6; Parameter: 7PK	F8-7657	
Rubber Buffer, suspension	1.5 dCi, 1.6, 1.6 dCi, 2.0, 2.0 dCi		F8-7800	H=68
<b>QASHQAI (J11, J11_)</b>			<b>11/2013 →</b>	
Alternator Freewheel Clutch	1.5 dCi		F5-1122	
<b>SERENA (C23M)</b>			<b>11/1992 → 09/2001</b>	
Bellow, steering	All Models	with clamps	LM-10087S	d1=11; d2=44; L [mm]=150
<b>SUNNY (B11)</b>			<b>03/1982 → 09/1987</b>	
Dust Cover Kit, shock absorber	1.3, 1.5, 1.7 D		AK-735088	
Bellow, steering	1.5, 1.7 D	09/1985 →; with clamps;	LM-10046S	d1=9; d2=44; L [mm]=160
<b>SUNNY Coupe (B11)</b>			<b>03/1982 → 10/1986</b>	
Dust Cover Kit, shock absorber	1.3, 1.5		AK-735088	
Bellow, steering	1.5	09/1985 →; with clamps;	LM-10046S	d1=9; d2=44; L [mm]=160
<b>SUNNY Estate (B11)</b>			<b>03/1982 → 10/1986</b>	
Dust Cover Kit, shock absorber	1.5, 1.7 D		AK-735088	
Bellow, steering	1.5, 1.7 D	09/1985 →; with clamps;	LM-10046S	d1=9; d2=44; L [mm]=160
<b>SUNNY Mk II (N13)</b>			<b>06/1986 → 10/1991</b>	
Dust Cover Kit, shock absorber	1.3, 1.4 LX, 1.5, 1.6, 1.6 GTI 16V, 1.6 i, 1.6 i 12V, 1.7 D		AK-735113	
Bellow, steering	1.3, 1.4 LX, 1.6, 1.6 i	with clamps;	LM-10046S	d1=9; d2=44; L [mm]=160

<b>AK-735088</b>	<b>AK-735113</b>	<b>AK-735245</b>	<b>AK-735436</b>	<b>AK-735442</b>	<b>F5-1071</b>	<b>F5-1110</b>
Ref.Nr.: 60585431	Ref.Nr.:	Ref.Nr.: 552404U000	Ref.Nr.: 54050JD00A	Ref.Nr.: 540502Y001	Ref.Nr.: 23151-6N20B	Ref.Nr.: 8200489514
<b>F5-1122</b>	<b>F5-1127</b>	<b>F5-1129</b>	<b>F8-7152</b>	<b>F8-7371</b>	<b>F8-7466</b>	<b>F8-7657</b>
Ref.Nr.:	Ref.Nr.: 23151-EL010	Ref.Nr.: 23151-JG71B	Ref.Nr.: 54325-AX000	Ref.Nr.: 54320-8H310	Ref.Nr.: 55320BM400	Ref.Nr.: 1230300Q0A
<b>F8-7800</b>	<b>LM-10046S</b>	<b>LM-10087S</b>				
Ref.Nr.: 55240JD000	Ref.Nr.: 48204-53A00	Ref.Nr.: 48203-9C000				

Article Description



Article Nr.

Fitting Position



<b>SUNNY Mk II (N13)</b>			<b>06/1986 → 10/1991</b>	
Bellow, steering	1.3, 1.4 LX, 1.6, 1.6 i	with clamps;	LM-10046S	
Bellow, steering	1.6 GTI 16V, 1.6 i 4x4, 1.7 D	with clamps	LM-10046S	
<b>SUNNY Mk II Coupe (B12)</b>			<b>06/1986 → 06/1991</b>	
Dust Cover Kit, shock absorber	1.5, 1.6, 1.6 GTI 16V, 1.6 i, 1.6 i 12V		AK-735113	
Bellow, steering	1.6, 1.6 i	with clamps;	LM-10046S	
Bellow, steering	1.8 GTI 16V	with clamps	LM-10046S	
<b>SUNNY Mk II Hatchback (N13)</b>			<b>06/1986 → 08/1991</b>	
Dust Cover Kit, shock absorber	1.3, 1.4 LX, 1.5, 1.6, 1.6 GTI 16V, 1.6 i, 1.6 i 12V, 1.7 D		AK-735113	
Bellow, steering	1.3, 1.4 LX, 1.6, 1.6 i	with clamps;	LM-10046S	
Bellow, steering	1.3, 1.4 LX, 1.6, 1.6 i	with clamps;	LM-10046S	
Bellow, steering	1.6 GTI 16V, 1.7 D, 1.8 GTI 16V	with clamps	LM-10046S	
<b>SUNNY Mk II Estate (B12)</b>			<b>01/1986 → 06/1991</b>	
Dust Cover Kit, shock absorber	1.5, 1.6, 1.6 i, 1.6 i 12V, 1.7 D		AK-735113	
Bellow, steering	1.6 i 4x4, 1.7 D	with clamps	LM-10046S	
Bellow, steering	1.6, 1.6 i	with clamps;	LM-10046S	
<b>SUNNY Mk III (N14)</b>			<b>05/1990 → 12/1996</b>	
Dust Cover Kit, shock absorber	1.4 i, 1.4 i 16V, 1.6 i, 1.6 i 16V, 2.0 D		AK-735113	
Dust Cover Kit, shock absorber	1.6 i, 1.6 i 16V, 1.6 i 16V 4WD		AK-735114	
Top Strut Mounting	1.4, 1.4 i, 1.4 i 16V, 1.6, 1.6 4x4, 1.6 i 16V, 1.6 i 16V 4WD, 1.6 SR 4x4, 1.8, 2.0, 2.0 D		F8-5945	
Top Strut Mounting	1.6 i	GA16DEL;	F8-5945	
Top Strut Mounting	1.4, 1.4 i, 1.4 i 16V, 1.6 4x4, 1.6 i, 1.6 i 16V, 1.6 i 16V 4WD, 1.6 SR 4x4, 2.0, 2.0 D		F8-5948	
<b>SUNNY Mk III Hatchback (N14)</b>			<b>10/1990 → 06/1995</b>	
Dust Cover Kit, shock absorber	1.4 i, 1.4 i 16V, 1.6 i, 1.6 i 16V, 2.0 D		AK-735113	
Dust Cover Kit, shock absorber	1.6 i, 1.6 i 16V, 2.0 GTI 16V, 2.0 GTI-R 4x4, 2.0 i 16V		AK-735114	
Top Strut Mounting	All Models		F8-5945	
Top Strut Mounting	All Models		F8-5948	
<b>SUNNY Mk III Hatchback (N14)</b>			<b>10/1990 → 06/1995</b>	
Dust Cover Kit, shock absorber	1.4 i, 1.4 i 16V, 1.6 i, 1.6 i 16V, 2.0 D		AK-735113	
Dust Cover Kit, shock absorber	1.6 i, 1.6 i 16V, 2.0 GTI 16V, 2.0 GTI-R 4x4, 2.0 i 16V		AK-735114	
Top Strut Mounting	All Models		F8-5945	
Top Strut Mounting	All Models		F8-5948	

<b>AK-735113</b>	<b>AK-735114</b>	<b>F8-5945</b>	<b>F8-5948</b>	<b>LM-10046S</b>
Ref.Nr.:	Ref.Nr.:	Ref.Nr.: 5432050Y12	Ref.Nr.: 55320-50Y10	Ref.Nr.: 48204-53A00

**Article Description****Article Nr.****Fitting Position**

<b>SUNNY Mk III Estate (Y10)</b>				<b>11/1990 → 03/2000</b>	
Dust Cover Kit, shock absorber	1.6 i, 2.0 D		<b>AK-735113</b>		
Top Strut Mounting	All Models		<b>F8-5945</b>		
Top Strut Mounting	1.6 i, 1.6 i 16V 4x4		<b>F8-5948</b>		
<b>SUNNY III Box (Y10)</b>				<b>11/1990 → 03/2000</b>	
Top Strut Mounting	All Models		<b>F8-5945</b>		
<b>SUNNY IV Saloon</b>				<b>04/2000 → 09/2003</b>	
Engine Mounting	1.8		<b>F8-8176</b>		
<b>SUNNY IV Coupe</b>				<b>04/2000 → 09/2003</b>	
Engine Mounting	All Models		<b>F8-8176</b>		
<b>SUNNY IV Hatchback</b>				<b>04/2000 → 09/2003</b>	
Engine Mounting	All Models		<b>F8-8176</b>		
<b>TEANA I (J31)</b>				<b>10/2003 → 06/2008</b>	
Alternator Freewheel Clutch	2.0		<b>F5-1071</b>		
<b>TEANA II (J32)</b>				<b>07/2008 → 09/2013</b>	
Alternator Freewheel Clutch	2.5		<b>F5-1071</b>		
Alternator Freewheel Clutch	2.5		<b>F5-1116</b>		
<b>TERRANO Mk II (R20)</b>				<b>05/2002 → 09/2007</b>	
Alternator Freewheel Clutch	3.0 Di 4WD		<b>F5-1035</b>		
<b>TERRANO II Van (R20)</b>				<b>04/2003 → 09/2007</b>	
Alternator Freewheel Clutch	3.0 Di 4WD		<b>F5-1035</b>		
<b>TIIDA Hatchback (C11X)</b>				<b>09/2007 →</b>	
Alternator Freewheel Clutch	1.5 dCi		<b>F5-1061</b>		
Alternator Freewheel Clutch	1.5 dCi		<b>F5-1122</b>		
Alternator Freewheel Clutch	1.8		<b>F5-1127</b>		
Anti-Friction Bearing	All Models		<b>F8-7152</b>		
<b>TIIDA Saloon (SC11X)</b>				<b>01/2007 →</b>	
Alternator Freewheel Clutch	1.5 dCi		<b>F5-1061</b>		
Alternator Freewheel Clutch	1.5 dCi		<b>F5-1122</b>		
Alternator Freewheel Clutch	1.8		<b>F5-1127</b>		
Anti-Friction Bearing	1.5 dCi, 1.6, 1.8		<b>F8-7152</b>		
<b>VANETTE CARGO Bus (HC 23)</b>				<b>01/1996 →</b>	
Bellow, steering	1.6 i, 2.0 D, 2.3 D	with clamps	<b>LM-10087S</b>		d1=11; d2=44; L [mm]=150

<b>AK-735113</b>	<b>F5-1035</b>	<b>F5-1061</b>	<b>F5-1071</b>	<b>F5-1116</b>	<b>F5-1122</b>	<b>F5-1127</b>
Ref.Nr.:	Ref.Nr.: 23150-2W200	Ref.Nr.: 7700110616	Ref.Nr.: 23151-6N20B	Ref.Nr.: 265031900	Ref.Nr.:	Ref.Nr.: 23151-EL010
<b>F8-5945</b>	<b>F8-5948</b>	<b>F8-7152</b>		<b>LM-10087S</b>		
Ref.Nr.: 5432050Y12	Ref.Nr.: 55320-50Y10	Ref.Nr.: 54325-AX000	Ref.Nr.: 11320BM500	Ref.Nr.: 48203-9C000		

Article Description



Article Nr.

Fitting Position



<b>VANETTE CARGO Box (HC 23)</b>			<b>01/1995 →</b>	
Bellow, steering	1.6 i, 2.0 D, 2.3 D	with clamps	<b>LM-10087S</b>	d1=11; d2=44; L [mm]=150
<b>X-TRAIL (T30)</b>			<b>06/2001 → 01/2013</b>	
Dust Cover Kit, shock absorber	All Models		<b>AK-735246</b>	⊕ ⊕
Alternator Freewheel Clutch	2.0, 2.0 4x4, 2.5 4x4		<b>F5-1071</b>	
Alternator Freewheel Clutch	2.5 4x4		<b>F5-1116</b>	
Top Strut Mounting	2.0, 2.0 4x4, 2.2 dCi, 2.2 dCi 4x4, 2.5 4x4		<b>F8-7371</b>	⊕ ⊕
<b>X-TRAIL (T31)</b>			<b>03/2007 → 11/2013</b>	
Alternator Freewheel Clutch	2.5		<b>F5-1071</b>	
Alternator Freewheel Clutch	2.0 dCi		<b>F5-1110</b>	
Alternator Freewheel Clutch	2.5		<b>F5-1116</b>	
Alternator Freewheel Clutch	2.0, 2.0 FWD		<b>F5-1127</b>	
Alternator Freewheel Clutch	2.0 dCi, 2.0 dCi FWD		<b>F5-1129</b>	
Anti-Friction Bearing	2.0, 2.0 dCi, 2.0 dCi FWD, 2.5		<b>F8-7152</b>	⊕ ⊕
Belt Pulley, crankshaft	2.0 dCi	Number of Ribs: 6; Parameter: 7PK	<b>F8-7657</b>	
<b>NOTE (E12)</b>			<b>06/2013 →</b>	
Alternator Freewheel Clutch	1.5 dCi		<b>F5-1130</b>	

<b>AK-735246</b>	<b>F5-1071</b>	<b>F5-1110</b>	<b>F5-1116</b>	<b>F5-1127</b>	<b>F5-1129</b>	<b>F5-1130</b>
Ref.Nr.: 5405031U02	Ref.Nr.: 23151-6N20B	Ref.Nr.: 8200489514	Ref.Nr.: 265031900	Ref.Nr.: 23151-EL010	Ref.Nr.: 23151-JG71B	Ref.Nr.: 23151-3VD1A
<b>F8-7152</b>	<b>F8-7371</b>	<b>F8-7657</b>	<b>LM-10087S</b>			
Ref.Nr.: 54325-AX000	Ref.Nr.: 54320-8H310	Ref.Nr.: 1230300Q0A	Ref.Nr.: 48203-9C000			

**Article Description****Article Nr.****Fitting Position**

<b>ADAM</b>				<b>10/2012 →</b>	
Top Strut Mounting	1.2, 1.4		<b>F8-7421</b>		
Spring Cap	1.2, 1.4		<b>F8-7422</b>		
Top Strut Mounting	1.2, 1.4		<b>F8-7423</b>		
Top Strut Mounting	1.2, 1.4		<b>F8-7424</b>		
Rubber Buffer, suspension	1.2, 1.4		<b>F8-7662</b>		H=40
Protective Cap/Bellow, shock absorber	1.2, 1.4		<b>F8-7663</b>		H=205
<b>AGILA (A) (H00)</b>				<b>09/2000 → 12/2007</b>	
Dust Cover Kit, shock absorber	1.0, 1.0 12V, 1.2 16V, 1.3 CDTI	ch.→YG 999 999	<b>AK-735078</b>		
Dust Cover Kit, shock absorber	All Models		<b>AK-735247</b>		
Alternator Freewheel Clutch	1.0, 1.2 16V Twinport, 1.3 CDTI		<b>F5-1041</b>		
Alternator Freewheel Clutch	1.0, 1.2 16V Twinport, 1.3 CDTI		<b>F5-1045</b>		
Control Arm-/Trailing Arm Bush	All Models		<b>F8-6585</b>		
Control Arm-/Trailing Arm Bush	All Models		<b>F8-7857</b>		
Repair Kit, link	All Models		<b>F8-7857S</b>		
<b>AGILA (B) (H08)</b>				<b>04/2008 →</b>	
Dust Cover Kit, shock absorber	1.0, 1.2, 1.3 CDTI		<b>AK-735437</b>		H=180
Rubber Buffer, suspension	1.0, 1.2, 1.3 CDTI		<b>F8-7326</b>		H=180
Top Strut Mounting	All Models		<b>F8-7624</b>		
<b>ANTARA</b>				<b>05/2006 →</b>	
Alternator Freewheel Clutch	2.0 CDTI		<b>F5-1001</b>		
<b>AMPERA</b>				<b>11/2011 →</b>	
Top Strut Mounting	All Models	; ; ; ;	<b>F8-7616</b>		H=49; D=114
<b>ARENA Combi (THB)</b>				<b>03/1998 → 08/2001</b>	
Bellow, steering	All Models	with clamps;	<b>LM-10002S</b>		d1=10; d2=40; L [mm]=160
<b>ARENA Box (TB, TF)</b>				<b>03/1998 → 08/2001</b>	
Bellow, steering	All Models	with clamps;	<b>LM-10002S</b>		d1=10; d2=40; L [mm]=160
<b>ASCONA B (81_, 86_, 87_, 88_)</b>				<b>09/1975 → 08/1981</b>	
Mounting, alternator	2.0 D		<b>F7-2054</b>		H=27; d=8; D1=18; D2=22
Mounting, alternator	1.2, 1.2 S, 1.3 N, 1.3 S, 1.6 N, 1.6 S, 1.9 N, 1.9 S, 2.0 D, 2.0 E, 2.0 N, 2.0 S		<b>F7-2055</b>		H=9; d=8; D=26
Stabiliser Mounting	1.2, 1.2 S	ch.Y2000001, Y5000001→	<b>F8-5230</b>		d=18
Mounting, stabilizer coupling rod	All Models		<b>F8-5333</b>		d=8.5; D=30

<b>AK-735078</b>	<b>AK-735247</b>	<b>AK-735437</b>	<b>F5-1001</b>	<b>F5-1041</b>	<b>F5-1045</b>	<b>F7-2054</b>
Ref.Nr.: 4705664	Ref.Nr.: 4705518	Ref.Nr.: 4708288	Ref.Nr.: 211242	Ref.Nr.: 77364723	Ref.Nr.: 77362721	Ref.Nr.: 1204879
<b>F7-2055</b>	<b>F8-5230</b>	<b>F8-5333</b>	<b>F8-5366</b>	<b>F8-6585</b>	<b>F8-7326</b>	<b>F8-7421</b>
Ref.Nr.: 1204892	Ref.Nr.: 0350138	Ref.Nr.: 2875013	Ref.Nr.: 1204885	Ref.Nr.: 96 380 613	Ref.Nr.: 4708288	Ref.Nr.: 51813225
<b>F8-7422</b>	<b>F8-7423</b>	<b>F8-7424</b>	<b>F8-7616</b>	<b>F8-7624</b>	<b>F8-7662</b>	<b>F8-7663</b>
Ref.Nr.: 344963	Ref.Nr.: 55701902	Ref.Nr.: 55703318	Ref.Nr.: 0344573	Ref.Nr.: 41710-57K00	Ref.Nr.: 0344956	Ref.Nr.: 344435

Article Description



Article Nr.

Fitting Position



<b>ASCONA B (81_, 86_, 87_, 88_)</b>			<b>09/1975 → 08/1981</b>		
Mounting, alternator	1.3 N, 1.3 S	Engine1073534→	<b>F8-5366</b>		
Mounting, alternator	1.6 N	Engine627870→	<b>F8-5366</b>		
Mounting, alternator	1.6 S	Engine702711→	<b>F8-5366</b>		
Mounting, alternator	1.9 N	Engine545150→	<b>F8-5366</b>		
Mounting, alternator	2.0 E	Engine173310→	<b>F8-5366</b>		
Mounting, alternator	2.0 N	Engine198154→	<b>F8-5366</b>		
Mounting, alternator	2.0 S	Engine667818→	<b>F8-5366</b>		
<b>ASCONA C (81_, 86_, 87_, 88_)</b>			<b>09/1981 → 08/1988</b>		
Dust Cover Kit, shock absorber	1.3 N, 1.3 S, 1.6, 1.6 D, 1.6 i, 1.6 i CAT, 1.6 S, 1.8, 1.8 E, 1.8 i, 2.0 i, 2.0 i CAT, 2.0 i GT		<b>AK-735003</b>		
Mounting, alternator	1.3 N, 1.3 S, 1.6, 1.6 D, 1.6 i CAT, 1.8 i		<b>F7-2055</b>		H=9; d=8; D=26
Anti-Friction Bearing	1.3 N, 1.3 S, 1.6, 1.6 D, 1.6 i, 1.6 i CAT, 1.6 S, 1.8, 1.8 E, 1.8 i, 2.0 i, 2.0 i CAT, 2.0 i GT		<b>F8-3024</b>		H=12; d=63; D=86
Mounting, axle beam	1.3 N, 1.3 S, 1.6, 1.6 D, 1.6 i, 1.6 i CAT, 1.6 S, 1.8, 1.8 E, 1.8 i, 2.0 i, 2.0 i CAT, 2.0 i GT	ch.→J1189306	<b>F8-3060</b>		H=75; d=12; D1=49; D2=57
Mounting, axle beam	2.0 i		<b>F8-3060</b>		H=75; d=12; D1=49; D2=57
Engine Mounting	1.3 N, 1.3 S, 1.6, 1.6 D, 1.6 S, 1.8 i	ch.DV165765→	<b>F8-4092</b>		
Engine Mounting	1.8, 1.8 E, 2.0 i, 2.0 i CAT, 2.0 i GT		<b>F8-4092</b>		
Engine Mounting	1.3 N, 1.3 S, 1.6, 1.6 S, 1.8 i	ch.DV165765→	<b>F8-4093</b>		
Engine Mounting	1.6, 1.6 i, 1.6 i CAT, 1.8, 1.8 E, 2.0 i, 2.0 i CAT, 2.0 i GT		<b>F8-4093</b>		
Control Arm-/Trailing Arm Bush	1.3 N, 1.3 S, 1.6, 1.6 D, 1.6 i, 1.6 i CAT, 1.6 S, 1.8, 1.8 E, 1.8 i, 2.0 i, 2.0 i CAT, 2.0 i GT		<b>F8-4094</b>		H=60; d=12; D1=36; D2=43
Mounting, axle beam	1.3 N, 1.3 S, 1.6, 1.6 D, 1.6 i, 1.6 i CAT, 1.6 S, 1.8, 1.8 E, 1.8 i, 2.0 i, 2.0 i CAT, 2.0 i GT	ch.J1189307→	<b>F8-4102</b>		H=74; d=12; D1=60; D2=66
Mounting, axle beam	2.0 i		<b>F8-4102</b>		H=74; d=12; D1=60; D2=66
Mounting, stabilizer coupling rod	1.3 N, 1.3 S, 1.6, 1.6 D, 1.6 i, 1.6 i CAT, 1.6 S, 1.8, 1.8 E, 1.8 i, 2.0 i, 2.0 i CAT, 2.0 i GT		<b>F8-5333</b>		d=8.5; D=30
Rubber Buffer, suspension	All Models		<b>F8-5611</b>		
Rubber Buffer, suspension	1.3 N, 1.3 S, 1.6, 1.6 D, 1.6 i, 1.6 i CAT, 1.6 S, 1.8, 1.8 E, 1.8 i, 2.0 i, 2.0 i CAT, 2.0 i GT		<b>F8-5710</b>		H=46
Top Strut Mounting	All Models		<b>F8-5952</b>		
Bellow, steering	1.3 N, 1.3 S, 1.6, 1.6 D, 1.6 i, 1.6 i CAT, 1.6 S, 1.8, 1.8 E, 1.8 i, 2.0 i, 2.0 i CAT, 2.0 i GT	with clamps	<b>LM-10045S</b>		d1=42; d2=52; L [mm]=165
Bellow Set, drive shaft	1.3 N, 1.3 S, 1.6, 1.6 i, 1.6 i CAT		<b>M-820820</b>		
Bellow, steering	1.3 N, 1.3 S, 1.6, 1.6 D, 1.6 i, 1.6 i CAT, 1.6 S, 1.8, 1.8 E, 1.8 i, 2.0 i, 2.0 i CAT, 2.0 i GT		<b>M-822300</b>		
C.V. Boot	1.6, 1.6 D, 1.6 S, 1.8, 1.8 E, 1.8 i, 2.0 i, 2.0 i CAT, 2.0 i GT	ch.N1000001, N2000001, N5000001→; ch.→N2733477, N5273484, P8202125	<b>M-822900</b>		
Bellow Set, drive shaft	1.3 N, 1.3 S, 1.6, 1.6 i, 1.6 i CAT		<b>MK-820820</b>		

<b>AK-735003</b>	<b>F7-2055</b>	<b>F8-3024</b>	<b>F8-3060</b>	<b>F8-4092</b>	<b>F8-4093</b>	<b>F8-4094</b>
Ref.Nr.:	Ref.Nr.: 1204892	Ref.Nr.: 90121275	Ref.Nr.: 90189050	Ref.Nr.: 90193760	Ref.Nr.: 90184728	Ref.Nr.: 90157161
<b>F8-4102</b>	<b>F8-5333</b>	<b>F8-5366</b>	<b>F8-5611</b>	<b>F8-5710</b>	<b>F8-5952</b>	<b>LM-10045S</b>
Ref.Nr.: 90372559	Ref.Nr.: 2875013	Ref.Nr.: 1204885	Ref.Nr.: 0436940	Ref.Nr.: 0344402	Ref.Nr.: 0344504	Ref.Nr.: 26024585
<b>M-820820</b>	<b>M-822300</b>	<b>M-822900</b>	<b>MK-820820</b>	<b>MK-822300</b>		
Ref.Nr.: 1603146	Ref.Nr.: 90090811	Ref.Nr.: 90421747	Ref.Nr.: 1603179	Ref.Nr.: 90345195		

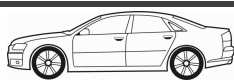
**Article Description****Article Nr.****Fitting Position**

<b>ASCONA C (81_, 86_, 87_, 88_)</b>		<b>09/1981 → 08/1988</b>	
Bellow, steering	1.3 N, 1.3 S, 1.6, 1.6 D, 1.6 i, 1.6 i CAT, 1.6 S, 1.8, 1.8 E, 1.8 i, 2.0 i, 2.0 i CAT, 2.0 i GT		MK-822300
Bellow, steering	2.0 i		MK-822300
Repair Kit, steering gear	1.3 N, 1.3 S, 1.6, 1.6 D, 1.6 i, 1.6 i CAT, 1.6 S, 1.8, 1.8 E, 1.8 i, 2.0 i, 2.0 i CAT, 2.0 i GT		MK-822300S
Repair Kit, steering gear	2.0 i		MK-822300S
Bellow Set, drive shaft	1.6, 1.6 D, 1.6 i, 1.6 i CAT, 1.6 S, 1.8, 1.8 E, 1.8 i, 2.0 i, 2.0 i CAT, 2.0 i GT		MK-822920
<b>ASCONA C Hatchback (84_, 89_)</b>		<b>09/1981 → 08/1988</b>	
Dust Cover Kit, shock absorber	All Models		AK-735003
Mounting, alternator	1.3 N, 1.3 S, 1.6, 1.6 D, 1.6 i CAT, 1.8 i		F7-2055
Anti-Friction Bearing	All Models		F8-3024
Mounting, axle beam	All Models	ch.→J1189306	F8-3060
Engine Mounting	1.3 N, 1.3 S, 1.6, 1.6 D, 1.6 S, 1.8 i	ch.DV165765→	F8-4092
Engine Mounting	1.8, 1.8 E, 2.0 i, 2.0 i CAT, 2.0 i GT		F8-4092
Engine Mounting	1.3 N, 1.3 S, 1.6, 1.6 S, 1.8 i	ch.DV165765→	F8-4093
Engine Mounting	1.6, 1.6 i, 1.6 i CAT, 1.8, 1.8 E, 2.0 i, 2.0 i CAT, 2.0 i GT		F8-4093
Control Arm-/Trailing Arm Bush	All Models		F8-4094
Mounting, axle beam	All Models	ch.J1189307→	F8-4102
Mounting, stabilizer coupling rod	All Models		F8-5333
Rubber Buffer, suspension	All Models		F8-5611
Rubber Buffer, suspension	All Models		F8-5710
Top Strut Mounting	All Models		F8-5952
Bellow, steering	All Models	with clamps	LM-10045S
Bellow Set, drive shaft	1.3 N, 1.3 S, 1.6, 1.6 i, 1.6 i CAT		M-820820
Bellow, steering	All Models		M-822300
C.V. Boot	1.6, 1.6 D, 1.6 S, 1.8, 1.8 E, 1.8 i, 2.0 i, 2.0 i CAT, 2.0 i GT	ch.N1000001, N2000001, N5000001→; ch.→N2733477, N5273484, P8202125	M-822900
Bellow Set, drive shaft	1.3 N, 1.3 S, 1.6, 1.6 i, 1.6 i CAT		MK-820820
Bellow, steering	All Models		MK-822300
Repair Kit, steering gear	All Models		MK-822300S
Bellow Set, drive shaft	1.6, 1.6 D, 1.6 i, 1.6 i CAT, 1.6 S, 1.8, 1.8 E, 1.8 i, 2.0 i, 2.0 i CAT, 2.0 i GT		MK-822920

<b>AK-735003</b>	<b>F7-2055</b>	<b>F8-3024</b>	<b>F8-3060</b>	<b>F8-4092</b>	<b>F8-4093</b>	<b>F8-4094</b>
Ref.Nr.:	Ref.Nr.: 1204892	Ref.Nr.: 90121275	Ref.Nr.: 90189050	Ref.Nr.: 90193760	Ref.Nr.: 90184728	Ref.Nr.: 90157161
<b>F8-4102</b>	<b>F8-5333</b>	<b>F8-5611</b>	<b>F8-5710</b>	<b>F8-5952</b>	<b>LM-10045S</b>	<b>M-820820</b>
Ref.Nr.: 90372559	Ref.Nr.: 2875013	Ref.Nr.: 0436940	Ref.Nr.: 0344402	Ref.Nr.: 0344504	Ref.Nr.: 26024585	Ref.Nr.: 1603146
<b>M-822300</b>	<b>M-822900</b>	<b>MK-820820</b>	<b>MK-822300</b>	<b>MK-822300S</b>	<b>MK-822920</b>	
Ref.Nr.: 90090811	Ref.Nr.: 90421747	Ref.Nr.: 1603179	Ref.Nr.: 90345195	Ref.Nr.: 902828	Ref.Nr.: 811498203	

Article Description



Article Nr.

Fitting Position



ASTRA F (56_, 57_)		09/1991 → 09/1998	
Dust Cover Kit, shock absorber	1.4, 1.4 i, 1.4 i 16V, 1.4 Si, 1.6, 1.6 i, 1.6 i 16V, 1.6 Si, 1.7 D, 1.7 TD, 1.7 TDS, 1.8 i, 1.8 i 16V, 2.0 i, 2.0 i 16V		AK-735005
Anti-Friction Bearing	1.4, 1.4 i, 1.4 i 16V, 1.4 Si, 1.6 i, 1.6 i 16V, 1.6 Si, 1.7 D, 1.7 TD, 1.7 TDS, 1.8 i, 1.8 i 16V, 2.0 i, 2.0 i 16V	ch.→T2677310	F8-3025  d=22
Mounting, axle beam	1.4, 1.4 i, 1.4 i 16V, 1.4 Si, 1.6, 1.6 i, 1.6 i 16V, 1.6 Si, 1.7 D, 1.7 TD, 1.7 TDS, 1.8 i, 1.8 i 16V, 2.0 i, 2.0 i 16V		F8-4102  H=74; d=12; D1=60; D2=66
Top Strut Mounting	1.4, 1.4 i, 1.4 i 16V, 1.4 Si, 1.6, 1.6 i, 1.6 i 16V, 1.6 Si, 1.7 D, 1.7 TD, 1.7 TDS, 1.8 i, 1.8 i 16V, 2.0 i, 2.0 i 16V		F8-5304
Top Strut Mounting	1.4, 1.4 i, 1.4 i 16V, 1.4 Si, 1.6, 1.6 i, 1.6 i 16V, 1.6 Si, 1.7 D, 1.7 TD, 1.7 TDS, 1.8 i, 1.8 i 16V, 2.0 i, 2.0 i 16V		F8-5304S
Stabiliser Mounting	1.4 i, 1.4 i 16V, 1.4 Si, 1.6 i, 1.6 i 16V, 1.6 Si, 1.7 D, 1.7 TD, 1.7 TDS, 1.8 i, 1.8 i 16V, 2.0 i, 2.0 i 16V		F8-5332  d=22
Stabiliser Mounting	1.4, 1.6		F8-5332  d=22
Mounting, stabilizer coupling rod	1.4, 1.4 i, 1.4 i 16V, 1.4 Si, 1.6 i, 1.6 i 16V, 1.6 Si, 1.7 D, 1.7 TD, 1.7 TDS, 1.8 i, 1.8 i 16V, 2.0 i, 2.0 i 16V		F8-5333  d=8.5; D=30
Control Arm-/Trailing Arm Bush	1.4 i, 1.4 i 16V, 1.4 Si, 1.6 i, 1.6 i 16V, 1.6 Si, 1.7 D, 1.7 TD, 1.7 TDS, 1.8 i, 1.8 i 16V, 2.0 i, 2.0 i 16V	ch.R2587416, R5111735, R8145950→	F8-5334  d=16; D=60; Thick. [mm]=58
Control Arm-/Trailing Arm Bush	1.4, 1.6		F8-5334  d=16; D=60; Thick. [mm]=58
Mounting, alternator	1.4	ch.→R2599999, R3999999, R4999999, R5999999, R6999999, R8999999;	F8-5366
Mounting, alternator	1.4 i, 1.4 Si, 1.6 i, 1.6 Si	ch.→R2599999, R3999999, R6999999, R8999999;	F8-5366
Engine Mounting	1.4 i 16V, 1.6 i 16V		F8-5372
Engine Mounting	1.4 Si		F8-5372
Engine Mounting	1.4, 1.4 i, 1.6 i, 1.6 Si		F8-5372
Engine Mounting	1.6	16 NZR;	F8-5372
Engine Mounting	1.8 i, 2.0 i	ch.2500001→; ch.→2999999	F8-5374
Engine Mounting	1.7 TD, 1.7 TDS		F8-5391
Engine Mounting	1.8 i 16V		F8-5418
Engine Mounting	2.0 i, 2.0 i 16V	ch.P2500001, P3000001, P5000001, P8000001→	F8-5418
Engine Mounting	1.6, 2.0 i		F8-5436
Engine Mounting	1.8 i, 1.8 i 16V, 2.0 i 16V		F8-5436
Engine Mounting	1.4		F8-5438
Engine Mounting	2.0 i	ch.N2500001→; ch.→N2999999	F8-5438
Engine Mounting	1.4, 1.4 i, 1.4 i 16V, 1.4 Si, 1.6 i 16V		F8-5439
Engine Mounting	1.7 D, 1.7 TD		F8-5439
Engine Mounting	1.4 i, 1.4 i 16V, 1.4 Si, 1.6 i, 1.6 i 16V, 1.6 Si		F8-5444
Engine Mounting	1.7 TDS	17 DT	F8-5444

<b>AK-735005</b>	<b>F8-3025</b>	<b>F8-4102</b>	<b>F8-5304</b>	<b>F8-5304S</b>	<b>F8-5332</b>	<b>F8-5333</b>
Ref.Nr.:	Ref.Nr.: 90374844	Ref.Nr.: 90372559	Ref.Nr.: 0344517	Ref.Nr.: 344531	Ref.Nr.: 0350078	Ref.Nr.: 2875013
<b>F8-5334</b>	<b>F8-5366</b>	<b>F8-5372</b>	<b>F8-5374</b>	<b>F8-5391</b>	<b>F8-5418</b>	<b>F8-5436</b>
Ref.Nr.: 352356	Ref.Nr.: 1204885	Ref.Nr.: 90278345	Ref.Nr.: 0684647	Ref.Nr.: 684643	Ref.Nr.: 684646	Ref.Nr.: 0684641
<b>F8-5438</b>	<b>F8-5439</b>	<b>F8-5444</b>	<b>F8-5445</b>			
Ref.Nr.: 684291	Ref.Nr.: 684289	Ref.Nr.: 90473852	Ref.Nr.: 0682504			



**Article Description****Article Nr.****Fitting Position**

<b>ASTRA F (56_, 57_)</b>			<b>09/1991 → 09/1998</b>	
Engine Mounting	1.7 D, 1.7 TD, 1.7 TDS, 1.8 i, 1.8 i 16V, 2.0 i 16V		<b>F8-5445</b>	
Engine Mounting	2.0 i	ch.→NA299999	<b>F8-5445</b>	
Engine Mounting	1.7 TDS		<b>F8-5462</b>	
Engine Mounting	1.6	16 NZR;	<b>F8-5467</b>	
Engine Mounting	1.6 i, 1.6 Si		<b>F8-5467</b>	
Engine Mounting	1.4, 1.4 i, 1.6 i, 1.6 Si		<b>F8-5468</b>	
Engine Mounting	1.4, 1.4 Si		<b>F8-5468</b>	
Engine Mounting	1.6		<b>F8-5468</b>	
Engine Mounting	1.7 D, 1.7 TD		<b>F8-5468</b>	
Engine Mounting	1.8 i	ch.→N1299999, N4999999, N5299999, NA299999, NE299999	<b>F8-5468</b>	
Rubber Buffer, suspension	1.4 i 16V, 1.4 Si, 1.6 i 16V, 1.6 Si, 1.7 TDS, 1.8 i 16V, 2.0 i, 2.0 i 16V		<b>F8-5710</b>	H=46
Control Arm-/Trailing Arm Bush	1.4, 1.4 i, 1.4 i 16V, 1.4 Si, 1.6, 1.6 i, 1.6 i 16V, 1.6 Si, 1.7 D, 1.7 TD, 1.7 TDS, 1.8 i, 1.8 i 16V, 2.0 i, 2.0 i 16V	ch.P2603823, P5000000, P8146890, PB000001→; ch.→R2587415, R5111734, R8145949, RB011797	<b>F8-5968</b>	d=12
Control Arm-/Trailing Arm Bush	1.4, 1.4 i, 1.4 i 16V, 1.4 Si, 1.6, 1.6 i, 1.6 i 16V, 1.6 Si, 1.7 D, 1.7 TD, 1.7 TDS, 1.8 i, 1.8 i 16V, 2.0 i, 2.0 i 16V	ch.P2603823, P5000000, P8146890, PB000001→; ch.→R2587415, R5111734, R8145949, RB011797	<b>F8-5969</b>	H=58; d=16; D=60
Sleeve, control arm mounting	1.4, 1.4 i, 1.4 i 16V, 1.4 Si, 1.6, 1.6 i, 1.6 i 16V, 1.6 Si, 1.7 D, 1.7 TD, 1.7 TDS, 1.8 i, 1.8 i 16V, 2.0 i, 2.0 i 16V		<b>F8-6656</b>	
Engine Mounting	1.4, 1.4 i 16V, 1.4 Si, 1.6 i, 1.6 i 16V, 1.6 Si, 1.8 i, 1.8 i 16V		<b>F8-6959</b>	
Engine Mounting	1.6	16 NZR;	<b>F8-6959</b>	
Engine Mounting	2.0 i, 2.0 i 16V		<b>F8-6959</b>	
Rubber Buffer, suspension	1.4, 1.4 i, 1.4 i 16V, 1.4 Si, 1.6, 1.6 i, 1.6 i 16V, 1.6 Si, 1.7 D, 1.7 TD, 1.7 TDS, 1.8 i, 1.8 i 16V, 2.0 i, 2.0 i 16V		<b>F8-7584</b>	H=68
Engine Mounting	1.4 i 16V, 1.6 i		<b>F8-8195</b>	
Control Arm-/Trailing Arm Bush	1.4 i, 1.4 Si, 1.6 i, 1.6 Si, 1.7 D, 1.7 TDS, 1.8 i, 1.8 i 16V, 2.0 i	ch.→R2595225, R5111734, R6036587, R8145949, RB011797	<b>G9-593</b>	d=12; D1=39; D2=44
Control Arm-/Trailing Arm Bush	1.4, 1.4 i 16V, 1.6, 1.6 i, 1.6 i 16V, 1.7 D, 1.7 TD, 1.8 i 16V, 2.0 i 16V		<b>G9-593</b>	d=12; D1=39; D2=44
Control Arm-/Trailing Arm Bush	1.4 i, 1.4 Si, 1.6 i, 1.6 Si, 1.7 D, 1.7 TDS, 1.8 i, 1.8 i 16V, 2.0 i	ch.R2595226, R5111735, R6036588, R8145950, RB011798→	<b>G9-594</b>	H1=27; H2=58; d=16; D1=60; D2=66
Control Arm-/Trailing Arm Bush	1.4, 1.4 i 16V, 1.6, 1.6 i, 1.6 i 16V, 1.7 D, 1.7 TD, 1.8 i 16V, 2.0 i 16V		<b>G9-594</b>	H1=27; H2=58; d=16; D1=60; D2=66
Bellow Set, drive shaft	1.4, 1.4 i, 1.4 i 16V, 1.4 Si, 1.6, 1.6 i, 1.6 i 16V, 1.6 Si		<b>M-820820</b>	
C.V. Boot	1.7 D, 1.8 i, 1.8 i 16V, 2.0 i, 2.0 i 16V	ch.N1000001, N2000001, N5000001→; ch.→N2733477, N5273484, P8202125	<b>M-822900</b>	
Bellow Set, drive shaft	1.4 i, 1.4 i 16V, 1.4 Si, 1.6 i, 1.6 i 16V, 1.6 Si	ch.→N4029608	<b>MK-820820</b>	
Bellow Set, drive shaft	1.4, 1.6		<b>MK-820820</b>	

<b>F8-5445</b>	<b>F8-5462</b>	<b>F8-5467</b>	<b>F8-5468</b>	<b>F8-5710</b>	<b>F8-5968</b>	<b>F8-5969</b>
Ref.Nr.: 0682504	Ref.Nr.: 684644	Ref.Nr.: 0684285	Ref.Nr.: 0684283	Ref.Nr.: 0344402	Ref.Nr.: 352351	Ref.Nr.: 352352
<b>F8-6656</b>	<b>F8-6959</b>	<b>F8-7584</b>	<b>F8-8195</b>	<b>G9-593</b>	<b>G9-594</b>	<b>M-820820</b>
Ref.Nr.: 4246062	Ref.Nr.: 0684134	Ref.Nr.: 0344401	Ref.Nr.: 5684051	Ref.Nr.: 90288232	Ref.Nr.: 90268463	Ref.Nr.: 1603146
<b>M-822900</b>	<b>MK-820820</b>	<b>MK-822920</b>				
Ref.Nr.: 90421747	Ref.Nr.: 1603179	Ref.Nr.: 811498203				

Article Description



Article Nr.

Fitting Position



<b>ASTRA F (56_, 57_)</b>		<b>09/1991 → 09/1998</b>	
Bellow Set, drive shaft	1.4, 1.4 i, 1.4 i 16V, 1.4 Si, 1.6, 1.6 i, 1.7 TD, 1.7 TDS, 1.8 i, 1.8 i 16V, 2.0 i, 2.0 i 16V	MK-822920	
Bellow Set, drive shaft	1.7 D	ch.→P2733477, P2733478, P5273484	MK-822920
<b>ASTRA F Convertible (53_B)</b>		<b>03/1993 → 03/2001</b>	
Dust Cover Kit, shock absorber	All Models	AK-735005	
Anti-Friction Bearing	All Models	ch.→T2677310	F8-3025  d=22
Mounting, axle beam	All Models	F8-4102	H=74; d=12; D1=60; D2=66
Top Strut Mounting	All Models	F8-5304	
Top Strut Mounting	All Models	F8-5304S	
Stabiliser Mounting	All Models	F8-5332	d=22
Mounting, stabilizer coupling rod	All Models	F8-5333	d=8.5; D=30
Control Arm-/Trailing Arm Bush	All Models	ch.R2587416, R5111735, R8145950→	F8-5334  d=16; D=60; Thick. [mm]=58
Mounting, alternator	1.4 Si, 1.6 i	ch.→R2599999, R3999999, R6999999, R8999999;	F8-5366
Engine Mounting	1.4 i 16V		F8-5372
Engine Mounting	1.4 Si		F8-5372
Engine Mounting	1.6 i		F8-5372
Engine Mounting	2.0 i	ch.2500001→; ch.→2999999	F8-5374
Engine Mounting	1.8 i 16V		F8-5418
Engine Mounting	2.0 i	ch.P2500001, P3000001, P5000001, P8000001→	F8-5418
Engine Mounting	1.8 i 16V		F8-5436
Engine Mounting	2.0 i		F8-5436
Engine Mounting	2.0 i	ch.N2500001→; ch.→N2999999	F8-5438
Engine Mounting	1.4 i 16V, 1.4 Si		F8-5439
Engine Mounting	1.4 i 16V, 1.4 Si, 1.6 i		F8-5444
Engine Mounting	1.8 i 16V		F8-5445
Engine Mounting	2.0 i	ch.→NA299999	F8-5445
Engine Mounting	1.6 i		F8-5467
Engine Mounting	1.4 Si		F8-5468
Engine Mounting	1.6 i		F8-5468
Rubber Buffer, suspension	1.4 i 16V, 1.4 Si, 1.8 i 16V, 2.0 i		F8-5710  H=46
Control Arm-/Trailing Arm Bush	All Models	ch.P2603823, P5000000, P8146890, PB000001→; ch.→R2587415, R5111734, R8145949, RB011797	F8-5968  d=12

<b>AK-735005</b>	<b>F8-3025</b>	<b>F8-4102</b>	<b>F8-5304</b>	<b>F8-5304S</b>	<b>F8-5332</b>	<b>F8-5333</b>
Ref.Nr.:	Ref.Nr.: 90374844	Ref.Nr.: 90372559	Ref.Nr.: 0344517	Ref.Nr.: 344531	Ref.Nr.: 0350078	Ref.Nr.: 2875013
<b>F8-5334</b>	<b>F8-5366</b>	<b>F8-5372</b>	<b>F8-5374</b>	<b>F8-5418</b>	<b>F8-5436</b>	<b>F8-5438</b>
Ref.Nr.: 352356	Ref.Nr.: 1204885	Ref.Nr.: 90278345	Ref.Nr.: 0684647	Ref.Nr.: 684646	Ref.Nr.: 0684641	Ref.Nr.: 684291
<b>F8-5439</b>	<b>F8-5444</b>	<b>F8-5445</b>	<b>F8-5467</b>	<b>F8-5468</b>	<b>F8-5710</b>	<b>F8-5968</b>
Ref.Nr.: 684289	Ref.Nr.: 90473852	Ref.Nr.: 0682504	Ref.Nr.: 0684285	Ref.Nr.: 0684283	Ref.Nr.: 0344402	Ref.Nr.: 352351

**Article Description****Article Nr.****Fitting Position****ASTRA F Convertible (53\_B) 03/1993 → 03/2001**

Control Arm-/Trailing Arm Bush	All Models	ch.P2603823, P5000000, P8146890, PB000001→; ch.→R2587415, R5111734, R8145949, RB011797	<b>F8-5969</b>		H=58; d=16; D=60
Sleeve, control arm mounting	All Models		<b>F8-6656</b>		
Engine Mounting	1.4 i 16V, 1.4 Si, 1.6 i, 1.8 i 16V		<b>F8-6959</b>		
Engine Mounting	2.0 i		<b>F8-6959</b>		
Rubber Buffer, suspension	All Models		<b>F8-7584</b>		H=68
Engine Mounting	1.4 i 16V, 1.6 i		<b>F8-8195</b>		
Control Arm-/Trailing Arm Bush	1.4 i 16V, 1.6 i, 1.8 i 16V		<b>G9-593</b>		d=12; D1=39; D2=44
Control Arm-/Trailing Arm Bush	1.4 Si, 1.6 i, 2.0 i	ch.→R2595225, R5111734, R6036587, R8145949, RB011797	<b>G9-593</b>		d=12; D1=39; D2=44
Control Arm-/Trailing Arm Bush	1.4 i 16V, 1.6 i, 1.8 i 16V		<b>G9-594</b>		H1=27; H2=58; d=16; D1=60; D2=66
Control Arm-/Trailing Arm Bush	1.4 Si, 1.6 i, 2.0 i	ch.R2595226, R5111735, R6036588, R8145950, RB011798→	<b>G9-594</b>		H1=27; H2=58; d=16; D1=60; D2=66
Bellow Set, drive shaft	1.4 i 16V, 1.4 Si, 1.6 i		<b>M-820820</b>		
C.V. Boot	1.8 i 16V, 2.0 i	ch.N1000001, N2000001, N5000001→; ch.→N2733477, N5273484, P8202125	<b>M-822900</b>		
Bellow Set, drive shaft	1.4 i 16V, 1.4 Si, 1.6 i	ch.→N4029608	<b>MK-820820</b>		
Bellow Set, drive shaft	All Models		<b>MK-822920</b>		

**ASTRA F Estate (51\_, 52\_) 09/1991 → 01/1998**

Dust Cover Kit, shock absorber	All Models		<b>AK-735005</b>		
Anti-Friction Bearing	1.4, 1.4 i, 1.4 i 16V, 1.4 Si, 1.6, 1.6 i, 1.6 i 16V, 1.6 Si, 1.7 D, 1.7 TD, 1.7 TDS, 1.8 i, 1.8 i 16V, 2.0 i, 2.0 i 16V	ch.→T2677310	<b>F8-3025</b>		d=22
Mounting, axle beam	All Models		<b>F8-4102</b>		H=74; d=12; D1=60; D2=66
Top Strut Mounting	All Models		<b>F8-5304</b>		
Top Strut Mounting	All Models		<b>F8-5304S</b>		
Stabiliser Mounting	1.4		<b>F8-5332</b>		d=22
Stabiliser Mounting	1.4, 1.4 i, 1.4 i 16V, 1.4 Si, 1.6, 1.6 i, 1.6 i 16V, 1.6 Si, 1.7 D, 1.7 TD, 1.7 TDS, 1.8 i, 1.8 i 16V, 2.0 i, 2.0 i 16V		<b>F8-5332</b>		d=22
Mounting, stabilizer coupling rod	1.4, 1.4 i, 1.4 i 16V, 1.4 Si, 1.6, 1.6 i, 1.6 i 16V, 1.6 Si, 1.7 D, 1.7 TD, 1.7 TDS, 1.8 i, 1.8 i 16V, 2.0 i, 2.0 i 16V		<b>F8-5333</b>		d=8.5; D=30
Control Arm-/Trailing Arm Bush	1.4		<b>F8-5334</b>		d=16; D=60; Thick. [mm]=58
Control Arm-/Trailing Arm Bush	1.4, 1.4 i, 1.4 i 16V, 1.4 Si, 1.6, 1.6 i, 1.6 i 16V, 1.6 Si, 1.7 D, 1.7 TD, 1.7 TDS, 1.8 i, 1.8 i 16V, 2.0 i, 2.0 i 16V	ch.R2587416, R5111735, R8145950→	<b>F8-5334</b>		d=16; D=60; Thick. [mm]=58
Mounting, alternator	1.4	ch.→R2599999, R3999999, R4999999, R5999999, R6999999, R8999999;	<b>F8-5366</b>		
Mounting, alternator	1.4, 1.4 i, 1.4 Si, 1.6 i, 1.6 Si	ch.→R2599999, R3999999, R6999999, R8999999;	<b>F8-5366</b>		

<b>AK-735005</b>	<b>F8-3025</b>	<b>F8-4102</b>	<b>F8-5304</b>	<b>F8-5304S</b>	<b>F8-5332</b>	<b>F8-5333</b>
Ref.Nr.:	Ref.Nr.: 90374844	Ref.Nr.: 90372559	Ref.Nr.: 0344517	Ref.Nr.: 344531	Ref.Nr.: 0350078	Ref.Nr.: 2875013
<b>F8-5334</b>	<b>F8-5366</b>	<b>F8-5372</b>	<b>F8-5969</b>	<b>F8-6656</b>	<b>F8-6959</b>	<b>F8-7584</b>
Ref.Nr.: 352356	Ref.Nr.: 1204885	Ref.Nr.: 90278345	Ref.Nr.: 352352	Ref.Nr.: 4246062	Ref.Nr.: 0684134	Ref.Nr.: 0344401
<b>F8-8195</b>	<b>G9-593</b>	<b>G9-594</b>	<b>M-820820</b>	<b>M-822900</b>	<b>MK-820820</b>	<b>MK-822920</b>
Ref.Nr.: 5684051	Ref.Nr.: 90288232	Ref.Nr.: 90268463	Ref.Nr.: 1603146	Ref.Nr.: 90421747	Ref.Nr.: 1603179	Ref.Nr.: 811498203

Article Description



Article Nr.

Fitting Position



ASTRA F Estate (51_, 52_)			09/1991 → 01/1998		
Engine Mounting	1.4		F8-5372		
Engine Mounting	1.4 i 16V, 1.6 i 16V		F8-5372		
Engine Mounting	1.4 Si		F8-5372		
Engine Mounting	1.4, 1.4 i, 1.6 i, 1.6 Si		F8-5372		
Engine Mounting	1.6	16 NZR;	F8-5372		
Engine Mounting	1.8 i, 2.0 i, 2.0 i 16V	ch.2500001→; ch.→2999999	F8-5374	↓	
Engine Mounting	1.7 TD, 1.7 TDS		F8-5391		
Engine Mounting	1.8 i 16V		F8-5418		
Engine Mounting	2.0 i, 2.0 i 16V	ch.P2500001, P3000001, P5000001, P8000001→	F8-5418		
Engine Mounting	1.6, 1.8 i, 1.8 i 16V, 2.0 i 16V		F8-5436		
Engine Mounting	2.0 i		F8-5436		
Engine Mounting	1.4		F8-5438		
Engine Mounting	2.0 i	ch.N2500001→; ch.→N2999999	F8-5438		
Engine Mounting	1.4, 1.4 i, 1.4 i 16V, 1.4 Si, 1.6 i 16V		F8-5439		
Engine Mounting	1.7 D, 1.7 TD		F8-5439		
Engine Mounting	1.4 i, 1.4 i 16V, 1.4 Si, 1.6 i, 1.6 i 16V, 1.6 Si		F8-5444		
Engine Mounting	1.6 i	C 16 NZ	F8-5444		
Engine Mounting	1.7 TDS	17 DT	F8-5444		
Engine Mounting	1.7 D, 1.7 TD, 1.7 TDS, 1.8 i, 1.8 i 16V, 2.0 i 16V		F8-5445	↓	
Engine Mounting	2.0 i	ch.→NA299999	F8-5445	↓	
Engine Mounting	1.7 TDS		F8-5462		
Engine Mounting	1.6	16 NZR;	F8-5467		
Engine Mounting	1.6 i, 1.6 Si		F8-5467		
Engine Mounting	1.4, 1.4 i, 1.6 i, 1.6 Si		F8-5468		
Engine Mounting	1.4, 1.4 Si		F8-5468		
Engine Mounting	1.6		F8-5468		
Engine Mounting	1.7 D, 1.7 TD		F8-5468		
Engine Mounting	1.8 i, 2.0 i 16V	ch.→N1299999, N4999999, N5299999, NA299999, NE299999	F8-5468		
Rubber Buffer, suspension	1.4 i 16V, 1.4 Si, 1.6, 1.6 Si, 1.7 TDS, 1.8 i 16V, 2.0 i, 2.0 i 16V		F8-5710		H=46
Control Arm-/Trailing Arm Bush	All Models	ch.P2603823, P5000000, P8146890, PB000001→; ch.→R2587415, R5111734, R8145949, RB011797	F8-5968		d=12
Control Arm-/Trailing Arm Bush	All Models	ch.P2603823, P5000000, P8146890, PB000001→; ch.→R2587415, R5111734, R8145949, RB011797	F8-5969		H=58; d=16; D=60



**Article Description****Article Nr.****Fitting Position**

<b>ASTRA F Estate (51_, 52_)</b>		<b>09/1991 → 01/1998</b>	
Sleeve, control arm mounting	All Models	<b>F8-6656</b>	
Engine Mounting	1.4, 1.4 i 16V, 1.4 Si, 1.6 i, 1.6 i 16V, 1.6 Si, 1.8 i, 1.8 i 16V	<b>F8-6959</b>	
Engine Mounting	1.6	<b>F8-6959</b>	
Engine Mounting	2.0 i, 2.0 i 16V	<b>F8-6959</b>	
Rubber Buffer, suspension	All Models	<b>F8-7584</b>	H=68
Engine Mounting	1.4 i 16V, 1.6 i	<b>F8-8195</b>	
Control Arm-/Trailing Arm Bush	1.4 i, 1.4 Si, 1.6 i, 1.6 Si, 1.7 D, 1.7 TDS, 1.8 i, 1.8 i 16V, 2.0 i 16V	<b>G9-593</b>	d=12; D1=39; D2=44
Control Arm-/Trailing Arm Bush	1.4, 1.4 i 16V, 1.6, 1.6 i, 1.6 i 16V, 1.7 D, 1.7 TD, 1.8 i 16V, 2.0 i, 2.0 i 16V	<b>G9-593</b>	d=12; D1=39; D2=44
Control Arm-/Trailing Arm Bush	1.4 i, 1.4 Si, 1.6 i, 1.6 Si, 1.7 D, 1.7 TDS, 1.8 i, 1.8 i 16V, 2.0 i 16V	<b>G9-594</b>	H1=27; H2=58; d=16; D1=60; D2=66
Control Arm-/Trailing Arm Bush	1.4, 1.4 i 16V, 1.6, 1.6 i, 1.6 i 16V, 1.7 D, 1.7 TD, 1.8 i 16V, 2.0 i, 2.0 i 16V	<b>G9-594</b>	H1=27; H2=58; d=16; D1=60; D2=66
Bellow Set, drive shaft	1.4, 1.4 i, 1.4 i 16V, 1.4 Si, 1.6, 1.6 i, 1.6 i 16V, 1.6 Si	<b>M-820820</b>	
C.V. Boot	1.7 D, 1.8 i, 1.8 i 16V, 2.0 i, 2.0 i 16V	<b>M-822900</b>	
Bellow Set, drive shaft	1.4 i, 1.4 i 16V, 1.4 Si, 1.6 i, 1.6 i 16V, 1.6 Si	<b>MK-820820</b>	
Bellow Set, drive shaft	1.4, 1.6	<b>MK-820820</b>	
Bellow Set, drive shaft	1.4, 1.4 i, 1.4 i 16V, 1.4 Si, 1.6, 1.6 i, 1.7 TD, 1.7 TDS, 1.8 i, 1.8 i 16V, 2.0 i, 2.0 i 16V	<b>MK-822920</b>	
Bellow Set, drive shaft	1.7 D	<b>MK-822920</b>	
<b>ASTRA F Hatchback (53_, 54_, 58_, 59_)</b>		<b>09/1991 → 01/1998</b>	
Dust Cover Kit, shock absorber	2.0 GSI 16V	<b>AK-735003</b>	
Dust Cover Kit, shock absorber	1.4, 1.4 i, 1.4 i 16V, 1.4 Si, 1.6, 1.6 i, 1.6 i 16V, 1.6 Si, 1.7 D, 1.7 TD, 1.7 TDS, 1.8 i, 1.8 i 16V, 2.0 i, 2.0 i 16V	<b>AK-735005</b>	
Anti-Friction Bearing	1.4, 1.4 i, 1.4 i 16V, 1.4 Si, 1.6, 1.6 i, 1.6 i 16V, 1.6 Si, 1.7 D, 1.7 TD, 1.7 TDS, 1.8 i, 1.8 i 16V, 2.0 GSI 16V, 2.0 i, 2.0 i 16V	<b>F8-3025</b>	d=22
Mounting, axle beam	All Models	<b>F8-4102</b>	H=74; d=12; D1=60; D2=66
Top Strut Mounting	All Models	<b>F8-5304</b>	
Top Strut Mounting	All Models	<b>F8-5304S</b>	
Stabiliser Mounting	1.4	<b>F8-5332</b>	d=22
Stabiliser Mounting	1.4, 1.4 i, 1.4 i 16V, 1.4 Si, 1.6, 1.6 i, 1.6 i 16V, 1.6 Si, 1.7 D, 1.7 TD, 1.7 TDS, 1.8 i, 1.8 i 16V, 2.0 GSI 16V, 2.0 i, 2.0 i 16V	<b>F8-5332</b>	d=22
Mounting, stabilizer coupling rod	1.4, 1.4 i, 1.4 i 16V, 1.4 Si, 1.6, 1.6 i, 1.6 i 16V, 1.6 Si, 1.7 D, 1.7 TD, 1.7 TDS, 1.8 i, 1.8 i 16V, 2.0 GSI 16V, 2.0 i, 2.0 i 16V	<b>F8-5333</b>	d=8.5; D=30

<b>AK-735003</b>	<b>AK-735005</b>	<b>F8-3025</b>	<b>F8-4102</b>	<b>F8-5304</b>	<b>F8-5304S</b>	<b>F8-5332</b>
Ref.Nr.:	Ref.Nr.:	Ref.Nr.: 90374844	Ref.Nr.: 90372559	Ref.Nr.: 0344517	Ref.Nr.: 344531	Ref.Nr.: 0350078
<b>F8-5333</b>	<b>F8-5334</b>	<b>F8-6656</b>	<b>F8-6959</b>	<b>F8-7584</b>	<b>F8-8195</b>	<b>G9-593</b>
Ref.Nr.: 2875013	Ref.Nr.: 352356	Ref.Nr.: 4246062	Ref.Nr.: 0684134	Ref.Nr.: 0344401	Ref.Nr.: 5684051	Ref.Nr.: 90288232
<b>G9-594</b>	<b>M-820820</b>	<b>M-822900</b>	<b>MK-820820</b>	<b>MK-822920</b>		
Ref.Nr.: 90268463	Ref.Nr.: 1603146	Ref.Nr.: 90421747	Ref.Nr.: 1603179	Ref.Nr.: 811498203		

Article Description



Article Nr.

Fitting Position



ASTRA F Hatchback (53_, 54_, 58_, 59_)		09/1991 → 01/1998	
Control Arm-/Trailing Arm Bush	1.4		F8-5334  d=16; D=60; Thick. [mm]=58
Control Arm-/Trailing Arm Bush	1.4, 1.4 i, 1.4 i 16V, 1.4 Si, 1.6, 1.6 i, 1.6 i 16V, 1.6 Si, 1.7 D, 1.7 TD, 1.7 TDS, 1.8 i, 1.8 i 16V, 2.0 GSI 16V, 2.0 i, 2.0 i 16V	ch.R2587416, R5111735, R8145950→	F8-5334  d=16; D=60; Thick. [mm]=58
Mounting, alternator	1.4	ch.→R2599999, R3999999, R4999999, R5999999, R6999999, R8999999;	F8-5366
Mounting, alternator	1.4, 1.4 i, 1.4 Si, 1.6 i, 1.6 Si	ch.→R2599999, R3999999, R6999999, R8999999;	F8-5366
Engine Mounting	1.4		F8-5372
Engine Mounting	1.4 i 16V, 1.6 i 16V		F8-5372
Engine Mounting	1.4 Si		F8-5372
Engine Mounting	1.4, 1.4 i, 1.6 i, 1.6 Si		F8-5372
Engine Mounting	1.6	16 NZR;	F8-5372
Engine Mounting	1.8 i, 2.0 GSI 16V, 2.0 i	ch.2500001→; ch.→2999999	F8-5374
Engine Mounting	1.7 TD, 1.7 TDS		F8-5391
Engine Mounting	1.8 i 16V		F8-5418
Engine Mounting	2.0 i, 2.0 i 16V	ch.P2500001, P3000001, P5000001, P8000001→	F8-5418
Engine Mounting	1.6, 1.8 i, 1.8 i 16V, 2.0 GSI 16V, 2.0 i 16V		F8-5436
Engine Mounting	2.0 i		F8-5436
Engine Mounting	1.4		F8-5438
Engine Mounting	2.0 i	ch.N2500001→; ch.→N2999999	F8-5438
Engine Mounting	1.4, 1.4 i, 1.4 i 16V, 1.4 Si, 1.6 i 16V		F8-5439
Engine Mounting	1.7 D, 1.7 TD		F8-5439
Engine Mounting	1.4 i, 1.4 i 16V, 1.4 Si, 1.6 i, 1.6 i 16V, 1.6 Si		F8-5444
Engine Mounting	1.6 i	C 16 NZ	F8-5444
Engine Mounting	1.7 TDS	17 DT	F8-5444
Engine Mounting	1.7 D, 1.7 TD, 1.7 TDS, 1.8 i, 1.8 i 16V, 2.0 i 16V		F8-5445
Engine Mounting	2.0 i	ch.→NA299999	F8-5445
Engine Mounting	1.7 TDS		F8-5462
Engine Mounting	1.6	16 NZR;	F8-5467
Engine Mounting	1.6 i		F8-5467
Engine Mounting	1.6 i, 1.6 Si		F8-5467
Engine Mounting	1.4, 1.4 i, 1.6 i, 1.6 Si		F8-5468
Engine Mounting	1.4, 1.4 Si		F8-5468
Engine Mounting	1.6		F8-5468



**Article Description****Article Nr.****Fitting Position**

<b>ASTRA F Hatchback (53, 54, 58, 59)</b>				<b>09/1991 → 01/1998</b>	
Engine Mounting	1.7 D, 1.7 TD		<b>F8-5468</b>		
Engine Mounting	1.8 i	ch.→N5299999	<b>F8-5468</b>		
Engine Mounting	2.0 GSI 16V	ch.N2500001, N4000001, N5000001, NA100001, NE100001→; ch.→N2999999, N4999999, N5999999, NA299999, NE299999	<b>F8-5468</b>		
Rubber Buffer, suspension	1.4 i 16V, 1.4 Si, 1.6, 1.6 Si, 1.7 TDS, 1.8 i 16V, 2.0 GSI 16V, 2.0 i		<b>F8-5710</b>		H=46
Control Arm-/Trailing Arm Bush	1.4, 1.4 i, 1.4 i 16V, 1.4 Si, 1.6, 1.6 i, 1.6 i 16V, 1.6 Si, 1.7 D, 1.7 TD, 1.7 TDS, 1.8 i, 1.8 i 16V, 2.0 i, 2.0 i 16V	ch.P2603823, P5000000, P8146890, PB000001→; ch.→R2587415, R5111734, R8145949, RB011797	<b>F8-5968</b>		d=12
Control Arm-/Trailing Arm Bush	All Models	ch.P2603823, P5000000, P8146890, PB000001→; ch.→R2587415, R5111734, R8145949, RB011797	<b>F8-5969</b>		H=58; d=16; D=60
Sleeve, control arm mounting	All Models		<b>F8-6656</b>		
Engine Mounting	1.4, 1.4 i 16V, 1.4 Si, 1.6 i, 1.6 i 16V, 1.6 Si, 1.8 i, 1.8 i 16V		<b>F8-6959</b>		
Engine Mounting	1.6	16 NZR;	<b>F8-6959</b>		
Engine Mounting	2.0 GSI 16V, 2.0 i, 2.0 i 16V	;	<b>F8-6959</b>		
Rubber Buffer, suspension	All Models		<b>F8-7584</b>		H=68
Control Arm-/Trailing Arm Bush	1.4 i, 1.4 Si, 1.6 i, 1.6 Si, 1.7 D, 1.7 TDS, 1.8 i, 2.0 GSI 16V, 2.0 i	ch.→R2595225, R5111734, R6036587, R8145949, RB011797	<b>G9-593</b>		d=12; D1=39; D2=44
Control Arm-/Trailing Arm Bush	1.4, 1.4 i 16V, 1.6, 1.6 i, 1.6 i 16V, 1.7 D, 1.7 TD, 1.8 i 16V, 2.0 i 16V		<b>G9-593</b>		d=12; D1=39; D2=44
Control Arm-/Trailing Arm Bush	1.4 i, 1.4 Si, 1.6 i, 1.6 Si, 1.7 D, 1.7 TDS, 1.8 i, 2.0 GSI 16V, 2.0 i	ch.R2595226, R5111735, R6036588, R8145950, RB011798→	<b>G9-594</b>		H1=27; H2=58; d=16; D1=60; D2=66
Control Arm-/Trailing Arm Bush	1.4, 1.4 i 16V, 1.6, 1.6 i, 1.6 i 16V, 1.7 D, 1.7 TD, 1.8 i 16V, 2.0 i 16V		<b>G9-594</b>		H1=27; H2=58; d=16; D1=60; D2=66
Bellow Set, drive shaft	1.4, 1.4 i, 1.4 i 16V, 1.4 Si, 1.6, 1.6 i, 1.6 i 16V, 1.6 Si		<b>M-820820</b>		
C.V. Boot	1.7 D, 1.8 i, 1.8 i 16V, 2.0 i, 2.0 i 16V	ch.N1000001, N2000001, N5000001→; ch.→N2733477, N5273484, P8202125	<b>M-822900</b>		
Bellow Set, drive shaft	1.4 i, 1.4 i 16V, 1.4 Si, 1.6 i, 1.6 i 16V, 1.6 Si	ch.→N4029608	<b>MK-820820</b>		
Bellow Set, drive shaft	1.4, 1.6		<b>MK-820820</b>		
Bellow Set, drive shaft	1.4, 1.4 i, 1.4 i 16V, 1.4 Si, 1.6, 1.6 i, 1.7 TD, 1.7 TDS, 1.8 i, 1.8 i 16V, 2.0 GSI 16V, 2.0 i, 2.0 i 16V		<b>MK-822920</b>		
Bellow Set, drive shaft	1.7 D	ch.→P2733477, P2733478, P5273484	<b>MK-822920</b>		
<b>ASTRA F CLASSIC Estate</b>				<b>01/1998 → 01/2005</b>	
Anti-Friction Bearing	1.4 i	ch.→T2677310	<b>F8-3025</b>		d=22
Mounting, axle beam	1.4 i, 1.6 i, 1.6 i 16V		<b>F8-4102</b>		H=74; d=12; D1=60; D2=66
Top Strut Mounting	1.4 i, 1.6 i, 1.6 i 16V		<b>F8-5304</b>		
Top Strut Mounting	1.4 i		<b>F8-5304S</b>		

<b>F8-3025</b>	<b>F8-4102</b>	<b>F8-5304</b>	<b>F8-5304S</b>	<b>F8-5332</b>	<b>F8-5468</b>	<b>F8-5710</b>
Ref.Nr.: 90374844	Ref.Nr.: 90372559	Ref.Nr.: 0344517	Ref.Nr.: 344531	Ref.Nr.: 0350078	Ref.Nr.: 0684283	Ref.Nr.: 0344402
<b>F8-5968</b>	<b>F8-5969</b>	<b>F8-6656</b>	<b>F8-6959</b>	<b>F8-7584</b>	<b>G9-593</b>	<b>G9-594</b>
Ref.Nr.: 352351	Ref.Nr.: 352352	Ref.Nr.: 4246062	Ref.Nr.: 0684134	Ref.Nr.: 0344401	Ref.Nr.: 90288232	Ref.Nr.: 90268463
<b>M-820820</b>	<b>M-822900</b>	<b>MK-820820</b>	<b>MK-822920</b>			
Ref.Nr.: 1603146	Ref.Nr.: 90421747	Ref.Nr.: 1603179	Ref.Nr.: 811498203			

Article Description



Article Nr.

Fitting Position



<b>ASTRA F CLASSIC Estate</b>		<b>01/1998 → 01/2005</b>	
Stabiliser Mounting	1.4 i, 1.6 i, 1.6 i 16V		<b>F8-5332</b>
Control Arm-/Trailing Arm Bush	1.4 i		<b>F8-5334</b>
Engine Mounting	1.4 i		<b>F8-5372</b>
Engine Mounting	1.6 i, 1.6 i 16V		<b>F8-5372</b>
Engine Mounting	1.4 i		<b>F8-5439</b>
Control Arm-/Trailing Arm Bush	1.4 i, 1.6 i 16V	ch.P2603823, P5000000, P8146890, PB000001→; ch.→R2587415, R5111734, R8145949, RB011797	<b>F8-5968</b>
Control Arm-/Trailing Arm Bush	1.4 i, 1.6 i, 1.6 i 16V	ch.P2603823, P5000000, P8146890, PB000001→; ch.→R2587415, R5111734, R8145949, RB011797	<b>F8-5969</b>
Sleeve, control arm mounting	1.4 i, 1.6 i, 1.6 i 16V		<b>F8-6656</b>
Rubber Buffer, suspension	1.4 i	<b>ST</b>	<b>F8-7584</b>
Control Arm-/Trailing Arm Bush	1.4 i, 1.6 i, 1.6 i 16V		<b>G9-593</b>
Control Arm-/Trailing Arm Bush	1.4 i, 1.6 i, 1.6 i 16V		<b>G9-594</b>
Bellow Set, drive shaft	1.6 i 16V		<b>M-820820</b>
Bellow Set, drive shaft	1.6 i 16V		<b>MK-820820</b>
<b>ASTRA F CLASSIC Hatchback</b>		<b>01/1998 → 08/2002</b>	
Mounting, axle beam	1.4 i, 1.6 i, 1.6 i 16V		<b>F8-4102</b>
Top Strut Mounting	1.4 i, 1.6 i, 1.6 i 16V		<b>F8-5304</b>
Stabiliser Mounting	1.4 i, 1.6 i, 1.6 i 16V		<b>F8-5332</b>
Control Arm-/Trailing Arm Bush	1.4 i, 1.6 i, 1.6 i 16V		<b>F8-5334</b>
Engine Mounting	1.4 i, 1.6 i, 1.6 i 16V		<b>F8-5372</b>
Control Arm-/Trailing Arm Bush	1.4 i, 1.6 i, 1.6 i 16V	ch.P2603823, P5000000, P8146890, PB000001→; ch.→R2587415, R5111734, R8145949, RB011797	<b>F8-5969</b>
Sleeve, control arm mounting	1.4 i, 1.6 i, 1.6 i 16V		<b>F8-6656</b>
Control Arm-/Trailing Arm Bush	1.4 i, 1.6 i, 1.6 i 16V		<b>G9-593</b>
Control Arm-/Trailing Arm Bush	1.4 i, 1.6 i, 1.6 i 16V		<b>G9-594</b>
<b>ASTRA F CLASSIC Saloon</b>		<b>01/1998 → 08/2002</b>	
Mounting, axle beam	All Models		<b>F8-4102</b>
Top Strut Mounting	All Models		<b>F8-5304</b>
Stabiliser Mounting	All Models		<b>F8-5332</b>

<b>F8-4102</b>	<b>F8-5304</b>	<b>F8-5332</b>	<b>F8-5334</b>	<b>F8-5372</b>	<b>F8-5439</b>	<b>F8-5968</b>
Ref.Nr.: 90372559	Ref.Nr.: 0344517	Ref.Nr.: 0350078	Ref.Nr.: 352356	Ref.Nr.: 90278345	Ref.Nr.: 684289	Ref.Nr.: 352351
<b>F8-5969</b>	<b>F8-6656</b>	<b>F8-7584</b>	<b>G9-593</b>	<b>G9-594</b>	<b>M-820820</b>	<b>MK-820820</b>
Ref.Nr.: 352352	Ref.Nr.: 4246062	Ref.Nr.: 0344401	Ref.Nr.: 90288232	Ref.Nr.: 90268463	Ref.Nr.: 1603146	Ref.Nr.: 1603179

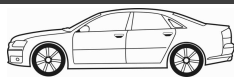

**Article Description****Article Nr.****Fitting Position**

<b>ASTRA F CLASSIC Saloon</b>			<b>01/1998 → 08/2002</b>		
Control Arm-/Trailing Arm Bush	All Models		<b>F8-5334</b>		d=16; D=60; Thick. [mm]=58
Engine Mounting	All Models		<b>F8-5372</b>		
Control Arm-/Trailing Arm Bush	All Models	ch.P2603823, P5000000, P8146890, PB000001→; ch.→R2587415, R5111734, R8145949, RB011797	<b>F8-5969</b>		H=58; d=16; D=60
Sleeve, control arm mounting	All Models		<b>F8-6656</b>		
Control Arm-/Trailing Arm Bush	All Models		<b>G9-593</b>		d=12; D1=39; D2=44
Control Arm-/Trailing Arm Bush	All Models		<b>G9-594</b>		H1=27; H2=58; d=16; D1=60; D2=66
<b>ASTRA F Van (55_)</b>			<b>10/1991 → 01/1999</b>		
Anti-Friction Bearing	1.4 i, 1.6 i, 1.7 D, 1.7 TD	ch.→T2677310	<b>F8-3025</b>		d=22
Mounting, axle beam	1.4 i, 1.6 i, 1.7 D, 1.7 TD		<b>F8-4102</b>		H=74; d=12; D1=60; D2=66
Top Strut Mounting	1.4 i, 1.6 i, 1.7 D, 1.7 TD		<b>F8-5304</b>		
Top Strut Mounting	1.4 i, 1.6 i, 1.7 D, 1.7 TD		<b>F8-5304S</b>		
Stabiliser Mounting	1.4 i, 1.6 i, 1.7 D, 1.7 TD		<b>F8-5332</b>		d=22
Control Arm-/Trailing Arm Bush	1.4 i, 1.6 i, 1.7 D, 1.7 TD		<b>F8-5334</b>		d=16; D=60; Thick. [mm]=58
Engine Mounting	1.4 i, 1.6 i		<b>F8-5444</b>		
Engine Mounting	1.6 i		<b>F8-5467</b>		
Sleeve, control arm mounting	1.4 i, 1.6 i, 1.7 D, 1.7 TD		<b>F8-6656</b>		
Engine Mounting	1.6 i		<b>F8-6959</b>		
Rubber Buffer, suspension	1.4 i, 1.6 i, 1.7 D, 1.7 TD	<b>ST</b>	<b>F8-7584</b>		H=68
Engine Mounting	1.6 i		<b>F8-8195</b>		
Control Arm-/Trailing Arm Bush	1.4 i, 1.6 i, 1.7 D	ch.→R2595225, R5111734, R6036587, R8145949, RB011797	<b>G9-593</b>		d=12; D1=39; D2=44
Control Arm-/Trailing Arm Bush	1.6 i, 1.7 D, 1.7 TD		<b>G9-593</b>		d=12; D1=39; D2=44
Control Arm-/Trailing Arm Bush	1.4 i, 1.6 i, 1.7 D	ch.R2595226, R5111735, R6036588, R8145950, RB011798→	<b>G9-594</b>		H1=27; H2=58; d=16; D1=60; D2=66
Control Arm-/Trailing Arm Bush	1.6 i, 1.7 D, 1.7 TD		<b>G9-594</b>		H1=27; H2=58; d=16; D1=60; D2=66
Bellow Set, drive shaft	1.4 i, 1.6 i, 1.7 D, 1.7 TD		<b>MK-822920</b>		
<b>ASTRA G Convertible (F67)</b>			<b>03/2001 → 10/2005</b>		
Alternator Freewheel Clutch	1.6 16V, 1.8 16V		<b>F5-1050</b>		
Alternator Freewheel Clutch	2.0 16V Turbo		<b>F5-1100</b>		
Control Arm-/Trailing Arm Bush	1.6 16V, 1.8 16V, 2.2 16V		<b>F8-4090</b>		H1=50; H2=59; d=12; D1=36; D2=43

<b>F5-1050</b>	<b>F5-1100</b>	<b>F8-3025</b>	<b>F8-4090</b>	<b>F8-4102</b>	<b>F8-5130</b>	<b>F8-5304</b>
Ref.Nr.: 1204412	Ref.Nr.: 1204393	Ref.Nr.: 90374844	Ref.Nr.: 4566899	Ref.Nr.: 90372559	Ref.Nr.: 352365	Ref.Nr.: 0344517
<b>F8-5304S</b>	<b>F8-5332</b>	<b>F8-5334</b>	<b>F8-5372</b>	<b>F8-5444</b>	<b>F8-5467</b>	<b>F8-5969</b>
Ref.Nr.: 344531	Ref.Nr.: 0350078	Ref.Nr.: 352356	Ref.Nr.: 90278345	Ref.Nr.: 90473852	Ref.Nr.: 0684285	Ref.Nr.: 352352
<b>F8-6656</b>	<b>F8-6959</b>	<b>F8-7584</b>	<b>F8-8195</b>	<b>G9-593</b>	<b>G9-594</b>	<b>MK-822920</b>
Ref.Nr.: 4246062	Ref.Nr.: 0684134	Ref.Nr.: 0344401	Ref.Nr.: 5684051	Ref.Nr.: 90288232	Ref.Nr.: 90268463	Ref.Nr.: 811498203

Article Description



Article Nr.

Fitting Position



<b>ASTRA G Convertible (F67)</b>			<b>03/2001 → 10/2005</b>		
Control Arm-/Trailing Arm Bush	1.6 16V, 1.8 16V, 2.2 16V		<b>F8-5130</b>		H=60; d=12; D=47
Engine Mounting	1.6 16V, 1.8 16V	Code: KZ YU;	<b>F8-5365</b>		
Top Strut Mounting	All Models	Bearing Type: Soft Version;	<b>F8-5448</b>		
Top Strut Mounting	All Models		<b>F8-5463</b>		
Belt Pulley, crankshaft	2.2 DTI	03/2003 →	<b>F8-5639</b>		
Rubber Buffer, suspension	All Models		<b>F8-5878</b>		H=62.5; d=24; D=50
Rubber Buffer, suspension	All Models		<b>F8-5913</b>		H=53; d=19; D=50
Engine Mounting	2.0 16V Turbo, 2.2 16V		<b>F8-6217</b>		
Rubber Buffer, suspension	All Models		<b>F8-6517</b>		
Mounting, axle beam	All Models		<b>F8-6733</b>		d=14; L=35; D1=46; D2=38.4
Mounting, axle beam	All Models		<b>F8-6734</b>		H=35.2; d=14.2; D1=45.9; D2=35.2
Engine Mounting	1.6, 1.6 16V, 1.8 16V	Yellow;	<b>F8-6755</b>		
Engine Mounting	1.6, 1.6 16V, 1.8 16V		<b>F8-6835</b>		
Engine Mounting	2.2 16V		<b>F8-6974</b>		
Spring Cap	All Models		<b>F8-7372</b>		
Rubber Buffer, suspension	All Models		<b>F8-7847</b>		
Mounting, axle beam	All Models		<b>F8-7913</b>		
Engine Mounting	1.6, 1.6 16V, 1.8 16V		<b>F8-8071</b>		
Repair Kit, suspension strut	All Models		<b>F8-8085</b>		
Engine Mounting	2.0 OPC, 2.2 16V, 2.2 DTI		<b>F8-8137</b>		
Engine Mounting	1.6 16V, 1.8 16V, 2.0 16V Turbo, 2.0 OPC, 2.2 DTI		<b>F8-8142</b>		
Engine Mounting	1.6 16V, 1.8 16V		<b>F8-8195</b>		
Repair Kit, suspension strut	All Models	Bearing Type: Hard Version;	<b>F8-8214</b>		
Bellow, steering	2.0 OPC	for steering gear manufacturer: Delphi; with clamps	<b>LM-10041S</b>		d1=13; d2=53; L [mm]=200
<b>ASTRA G Estate (F35_)</b>			<b>02/1998 → 12/2009</b>		
Rubber Buffer, suspension	1.2 16V, 1.4 16V, 1.6, 1.6 16V, 1.6 CNG, 1.7 CDTI, 1.7 DTI 16V, 1.7 TD, 1.8 16V, 2.0 16V, 2.0 DI, 2.0 DTI 16V, 2.0 OPC, 2.2 16V, 2.2 DTI		<b>AK-735038</b>		
Alternator Freewheel Clutch	1.7 CDTI		<b>F5-1049</b>		
Alternator Freewheel Clutch	1.4 16V, 1.6, 1.6 16V, 1.6 CNG, 1.8 16V, 2.0 16V		<b>F5-1050</b>		
Alternator Freewheel Clutch	2.0 OPC		<b>F5-1100</b>		
Control Arm-/Trailing Arm Bush	1.2 16V, 1.4 16V, 1.6, 1.6 16V, 1.7 DTI 16V, 1.7 TD, 1.8 16V, 2.0 16V, 2.0 DI, 2.0 DTI 16V, 2.2 16V		<b>F8-4090</b>		H1=50; H2=59; d=12; D1=36; D2=43
Control Arm-/Trailing Arm Bush	1.2 16V, 1.4 16V, 1.6, 1.6 16V, 1.7 DTI 16V, 1.7 TD, 1.8 16V, 2.0 16V, 2.0 DI, 2.0 DTI 16V, 2.2 16V		<b>F8-5130</b>		H=60; d=12; D=47

<b>AK-735038</b>	<b>F5-1049</b>	<b>F5-1050</b>	<b>F5-1100</b>	<b>F8-4090</b>	<b>F8-5130</b>	<b>F8-5230</b>
Ref.Nr.: 344417	Ref.Nr.: 1204366	Ref.Nr.: 1204412	Ref.Nr.: 1204393	Ref.Nr.: 4566899	Ref.Nr.: 352365	Ref.Nr.: 0350138
<b>F8-5365</b>	<b>F8-5448</b>	<b>F8-5463</b>	<b>F8-5639</b>	<b>F8-5878</b>	<b>F8-5913</b>	<b>F8-6217</b>
Ref.Nr.: 5684045	Ref.Nr.: 0344523	Ref.Nr.: 0344525	Ref.Nr.: 0614411	Ref.Nr.: 0344417	Ref.Nr.: 0344421	Ref.Nr.: 684168
<b>F8-6517</b>	<b>F8-6733</b>	<b>F8-6734</b>	<b>F8-6755</b>	<b>F8-6835</b>	<b>F8-6974</b>	<b>F8-7372</b>
Ref.Nr.: 90468618	Ref.Nr.: 13107328	Ref.Nr.: 302275	Ref.Nr.: 90575457	Ref.Nr.: 684694	Ref.Nr.: 684249	Ref.Nr.: 0344591

**Article Description****Article Nr.****Fitting Position**

<b>ASTRA G Estate (F35_)</b>			<b>02/1998 → 12/2009</b>		
Stabiliser Mounting	1.2 16V	ch.Y2000001, Y5000001→	<b>F8-5230</b>		d=18
Stabiliser Mounting	1.4 16V, 1.6, 1.6 16V, 1.7 TD, 1.8 16V, 2.0 16V, 2.0 DI, 2.0 DTI 16V		<b>F8-5230</b>		d=18
Engine Mounting	1.2 16V, 1.4 16V, 1.6, 1.6 16V, 1.8 16V	Code: KZ YU;	<b>F8-5365</b>		
Engine Mounting	1.2 16V, 1.6, 1.7 CDTI, 1.7 TD		<b>F8-5368</b>		
Engine Mounting	1.6, 1.7 DTI 16V		<b>F8-5368</b>		
Engine Mounting	1.4 16V	X 14 XE	<b>F8-5444</b>		
Engine Mounting	1.6		<b>F8-5444</b>		
Engine Mounting	1.6 16V	X 16 XEL	<b>F8-5444</b>		
Top Strut Mounting	1.2 16V, 1.4 16V, 1.6, 1.6 16V, 1.6 CNG, 1.7 CDTI, 1.7 DTI 16V, 1.7 TD, 1.8 16V, 2.0 16V, 2.0 DI, 2.0 DTI 16V, 2.0 OPC, 2.2 16V, 2.2 DTI	Bearing Type: Soft Version;	<b>F8-5448</b>		
Top Strut Mounting	1.2 16V, 1.4 16V, 1.6, 1.6 16V, 1.6 CNG, 1.7 CDTI, 1.7 DTI 16V, 1.7 TD, 1.8 16V, 2.0 16V, 2.0 DI, 2.0 DTI 16V, 2.0 OPC, 2.2 16V, 2.2 DTI	;	<b>F8-5463</b>		
Belt Pulley, crankshaft	2.0 DI, 2.0 DTI 16V, 2.2 DTI		<b>F8-5639</b>		
Rubber Buffer, suspension	1.2 16V, 1.4 16V, 1.6, 1.6 16V, 1.7 CDTI, 1.7 DTI 16V, 1.7 TD, 1.8 16V, 2.0 16V, 2.0 DI, 2.0 DTI 16V, 2.0 OPC, 2.2 16V, 2.2 DTI		<b>F8-5878</b>		H=62.5; d=24; D=50
Rubber Buffer, suspension	1.2 16V, 1.4 16V, 1.6, 1.6 16V, 1.7 CDTI, 1.7 DTI 16V, 1.7 TD, 1.8 16V, 2.0 16V, 2.0 DI, 2.0 DTI 16V, 2.0 OPC, 2.2 16V, 2.2 DTI		<b>F8-5913</b>		H=53; d=19; D=50
Engine Mounting	2.0 OPC, 2.2 16V		<b>F8-6217</b>		
Engine Mounting	2.0 DI, 2.0 DTI 16V		<b>F8-6494</b>		
Rubber Buffer, suspension	All Models		<b>F8-6517</b>		
Mounting, axle beam	All Models		<b>F8-6733</b>		d=14; L=35; D1=46; D2=38.4
Mounting, axle beam	All Models		<b>F8-6734</b>		H=35.2; d=14.2; D1=45.9; D2=35.2
Engine Mounting	1.4 16V, 1.6, 1.6 16V, 1.8 16V	Yellow;	<b>F8-6755</b>		
Engine Mounting	1.7 CDTI, 1.7 DTI 16V, 1.7 TD	Yellow	<b>F8-6755</b>		
Engine Mounting	1.4 16V, 1.6, 1.6 16V, 1.6 CNG, 1.8 16V		<b>F8-6835</b>		
Engine Mounting	1.7 CDTI	Engine →30231947, 35023929, 38000636	<b>F8-6836</b>		
Engine Mounting	1.7 DTI 16V, 1.7 TD		<b>F8-6836</b>		
Engine Mounting	2.0 DI, 2.0 DTI 16V	ch.32000001, 35000001, 36000001, 38000001, 3B000001, 3H000001, 4G000001→	<b>F8-6836</b>		
Engine Mounting	2.2 16V		<b>F8-6974</b>		
Belt Pulley, crankshaft	1.7 CDTI, 1.7 DTI 16V	Number of Ribs: 6	<b>F8-7089</b>		Belt Pulley Ø [mm]=141; Mounting points diam.[mm]=48; W=27.5

<b>F8-5230</b>	<b>F8-5365</b>	<b>F8-5368</b>	<b>F8-5444</b>	<b>F8-5448</b>	<b>F8-5463</b>	<b>F8-5639</b>
Ref.Nr.: 0350138	Ref.Nr.: 5684045	Ref.Nr.: 0684692	Ref.Nr.: 90473852	Ref.Nr.: 0344523	Ref.Nr.: 0344525	Ref.Nr.: 0614411
<b>F8-5878</b>	<b>F8-5913</b>	<b>F8-6217</b>	<b>F8-6494</b>	<b>F8-6517</b>	<b>F8-6733</b>	<b>F8-6734</b>
Ref.Nr.: 0344417	Ref.Nr.: 0344421	Ref.Nr.: 684168	Ref.Nr.: 0 684 697	Ref.Nr.: 90468618	Ref.Nr.: 13107328	Ref.Nr.: 302275
<b>F8-6755</b>	<b>F8-6835</b>	<b>F8-6836</b>	<b>F8-6974</b>	<b>F8-7089</b>	<b>F8-7372</b>	
Ref.Nr.: 90575457	Ref.Nr.: 684694	Ref.Nr.: 24427298	Ref.Nr.: 684249	Ref.Nr.: 5614444	Ref.Nr.: 0344591	

Article Description



Article Nr.

Fitting Position



<b>ASTRA G Estate (F35_)</b>		<b>02/1998 → 12/2009</b>			
Spring Cap	All Models	F8-7372			
Rubber Buffer, suspension	1.7 DTI 16V	F8-7847			
Belt Pulley, crankshaft	1.7 TD	F8-7869			
Mounting, axle beam	All Models	F8-7913			
Engine Mounting	1.4 16V, 1.6, 1.6 16V, 1.8 16V	F8-8071			
Repair Kit, suspension strut	All Models	F8-8085			
Engine Mounting	2.0 DI, 2.0 DTI 16V, 2.0 OPC, 2.2 16V, 2.2 DTI	F8-8137			
Engine Mounting	1.2 16V, 1.4 16V, 1.6, 1.6 16V, 1.6 CNG, 1.7 CDTI, 1.7 DTI 16V, 1.7 TD, 1.8 16V, 2.0 16V, 2.0 OPC, 2.2 DTI	F8-8142			
Engine Mounting	2.0 16V	F8-8155			
Engine Mounting	2.0 DI, 2.0 DTI 16V	F8-8155			
Engine Mounting	1.2 16V, 1.4 16V, 1.6, 1.6 16V, 1.6 CNG, 1.8 16V	F8-8195			
Repair Kit, suspension strut	1.2 16V, 1.4, 1.4 16V, 1.6, 1.6 16V, 1.6 CNG, 1.7 CDTI, 1.7 DTI 16V, 1.7 TD, 1.8 16V, 2.0 16V, 2.0 DI, 2.0 DTI 16V, 2.0 OPC, 2.2 16V, 2.2 DTI	Bearing Type: Hard Version; ch.Y50000001, Y60000001, Y80000001→; ; not for	F8-8214		
Bellow, steering	2.0 OPC	for steering gear manufacturer: Delphi; with clamps	LM-10041S		d1=13; d2=53; L [mm]=200

<b>ASTRA G Hatchback (F48_, F08_)</b>		<b>02/1998 → 12/2009</b>			
Rubber Buffer, suspension	1.2 16V, 1.4 16V, 1.6, 1.6 16V, 1.7 CDTI, 1.7 DTI 16V, 1.7 TD, 1.8 16V, 2.0 16V, 2.0 16V OPC, 2.0 DI, 2.0 DTI 16V, 2.0 OPC, 2.2 16V, 2.2 DTI	AK-735038			
Alternator Freewheel Clutch	1.2 16V, 1.4	F5-1041			
Alternator Freewheel Clutch	1.2 16V, 1.4	F5-1045			
Alternator Freewheel Clutch	1.7 CDTI	F5-1049			
Alternator Freewheel Clutch	1.4 16V, 1.6, 1.6 16V, 1.8, 1.8 16V, 2.0 16V, 2.0 16V OPC	F5-1050			
Alternator Freewheel Clutch	2.0 OPC	F5-1100			
Control Arm-/Trailing Arm Bush	1.2 16V, 1.4 16V, 1.6, 1.6 16V, 1.7 DTI 16V, 1.7 TD, 1.8 16V, 2.0 16V, 2.0 16V OPC, 2.0 DI, 2.0 DTI 16V, 2.2 16V	F8-4090		H1=50; H2=59; d=12; D1=36; D2=43	
Control Arm-/Trailing Arm Bush	1.2 16V, 1.4 16V, 1.6, 1.6 16V, 1.7 DTI 16V, 1.7 TD, 1.8 16V, 2.0 16V, 2.0 16V OPC, 2.0 DI, 2.0 DTI 16V, 2.2 16V	F8-5130		H=60; d=12; D=47	
Stabiliser Mounting	1.2 16V	ch.→X2999999, X5999999, X6999999, X8999999	F8-5211		d=16
Stabiliser Mounting	1.2 16V	ch.Y2000001, Y5000001→	F8-5230		d=18
Stabiliser Mounting	1.4 16V, 1.6, 1.6 16V, 1.7 TD, 1.8 16V, 2.0 16V, 2.0 16V OPC, 2.0 DI, 2.0 DTI 16V		F8-5230		d=18
Engine Mounting	1.2 16V, 1.4 16V, 1.6, 1.6 16V, 1.8 16V	Code: KZ YU;	F8-5365		

<b>AK-735038</b>	<b>F5-1041</b>	<b>F5-1045</b>	<b>F5-1049</b>	<b>F5-1050</b>	<b>F5-1100</b>	<b>F8-4090</b>
Ref.Nr.: 344417	Ref.Nr.: 77364723	Ref.Nr.: 77362721	Ref.Nr.: 1204366	Ref.Nr.: 1204412	Ref.Nr.: 1204393	Ref.Nr.: 4566899
<b>F8-5130</b>	<b>F8-5211</b>	<b>F8-5230</b>	<b>F8-5365</b>	<b>F8-5368</b>	<b>F8-7372</b>	<b>F8-7847</b>
Ref.Nr.: 352365	Ref.Nr.: 0350130	Ref.Nr.: 0350138	Ref.Nr.: 5684045	Ref.Nr.: 0684692	Ref.Nr.: 0344591	Ref.Nr.: 90576351
<b>F8-7869</b>	<b>F8-7913</b>	<b>F8-8071</b>	<b>F8-8085</b>	<b>F8-8137</b>	<b>F8-8142</b>	<b>F8-8155</b>
Ref.Nr.: 5614427	Ref.Nr.: 5402638	Ref.Nr.: 684693	Ref.Nr.: 344523	Ref.Nr.: 682502	Ref.Nr.: 90538582	Ref.Nr.: 5684048

**Article Description****Article Nr.****Fitting Position**

<b>ASTRA G Hatchback (F48_, F08_)</b>			<b>02/1998 → 12/2009</b>		
Engine Mounting	1.2 16V, 1.6, 1.7 CDTI, 1.7 TD		<b>F8-5368</b>		
Engine Mounting	1.6, 1.7 DTI 16V		<b>F8-5368</b>		
Engine Mounting	1.4 16V	X 14 XE	<b>F8-5444</b>		
Engine Mounting	1.6		<b>F8-5444</b>		
Engine Mounting	1.6 16V	X 16 XEL	<b>F8-5444</b>		
Top Strut Mounting	1.2 16V, 1.4 16V, 1.6, 1.6 16V, 1.7 CDTI, 1.7 DTI 16V, 1.7 TD, 1.8 16V, 2.0 16V, 2.0 16V OPC, 2.0 DI, 2.0 DTI 16V, 2.0 OPC, 2.2 16V, 2.2 DTI	Bearing Type: Soft Version;	<b>F8-5448</b>	⊕ ⊕	
Top Strut Mounting	1.2 16V, 1.4 16V, 1.6, 1.6 16V, 1.7 CDTI, 1.7 DTI 16V, 1.7 TD, 1.8, 1.8 16V, 2.0 16V, 2.0 16V OPC, 2.0 DI, 2.0 DTI 16V, 2.0 OPC, 2.2 16V, 2.2 DTI	;	<b>F8-5463</b>	⊕ ⊕	
Belt Pulley, crankshaft	2.0 DI, 2.0 DTI 16V, 2.2 DTI		<b>F8-5639</b>		
Rubber Buffer, suspension	1.2 16V, 1.4 16V, 1.6, 1.6 16V, 1.7 CDTI, 1.7 DTI 16V, 1.7 TD, 1.8 16V, 2.0 16V, 2.0 16V OPC, 2.0 DI, 2.0 DTI 16V, 2.0 OPC, 2.2 16V, 2.2 DTI		<b>F8-5878</b>	⊕ ⊕	H=62.5; d=24; D=50
Rubber Buffer, suspension	1.2 16V, 1.4 16V, 1.6, 1.6 16V, 1.7 CDTI, 1.7 DTI 16V, 1.7 TD, 1.8 16V, 2.0 16V, 2.0 16V OPC, 2.0 DI, 2.0 DTI 16V, 2.0 OPC, 2.2 16V, 2.2 DTI		<b>F8-5913</b>	⊕ ⊕	H=53; d=19; D=50
Engine Mounting	2.0 OPC, 2.2 16V		<b>F8-6217</b>		
Engine Mounting	2.0 DI, 2.0 DTI 16V		<b>F8-6494</b>		
Rubber Buffer, suspension	1.0, 1.2 16V, 1.4, 1.4 16V, 1.6, 1.6 16V, 1.7 CDTI, 1.7 DTI 16V, 1.7 TD, 1.8, 1.8 16V, 2.0 16V, 2.0 16V OPC, 2.0 DI, 2.0 DTI 16V, 2.0 OPC, 2.2 16V, 2.2 DTI		<b>F8-6517</b>	⊕ ⊕ ↑	
Mounting, axle beam	1.0, 1.2 16V, 1.4, 1.4 16V, 1.6, 1.6 16V, 1.7 CDTI, 1.7 DTI 16V, 1.7 TD, 1.8, 1.8 16V, 2.0 16V, 2.0 16V OPC, 2.0 DI, 2.0 DTI 16V, 2.0 OPC, 2.2 16V, 2.2 DTI		<b>F8-6733</b>	⊕ ⊕	d=14; L=35; D1=46; D2=38.4
Mounting, axle beam	1.0, 1.2 16V, 1.4, 1.4 16V, 1.6, 1.6 16V, 1.7 CDTI, 1.7 DTI 16V, 1.7 TD, 1.8, 1.8 16V, 2.0 16V, 2.0 16V OPC, 2.0 DI, 2.0 DTI 16V, 2.0 OPC, 2.2 16V, 2.2 DTI		<b>F8-6734</b>	⊕ ⊕	H=35.2; d=14.2; D1=45.9; D2=35.2
Engine Mounting	1.4 16V, 1.6, 1.6 16V, 1.8 16V	Yellow;	<b>F8-6755</b>	⊕	
Engine Mounting	1.7 CDTI, 1.7 DTI 16V, 1.7 TD	Yellow	<b>F8-6755</b>	⊕	
Engine Mounting	1.4 16V, 1.6, 1.6 16V, 1.8 16V		<b>F8-6835</b>		
Engine Mounting	1.7 CDTI	Engine →30231947, 35023929, 38000636	<b>F8-6836</b>	⊕	
Engine Mounting	1.7 DTI 16V, 1.7 TD		<b>F8-6836</b>	⊕	
Engine Mounting	2.0 DI, 2.0 DTI 16V	ch.32000001, 35000001, 36000001, 38000001, 3B000001, 3H000001, 4G000001→	<b>F8-6836</b>	⊕	
Engine Mounting	2.2 16V		<b>F8-6974</b>		
Belt Pulley, crankshaft	1.7 CDTI, 1.7 DTI 16V	Number of Ribs: 6	<b>F8-7089</b>		Belt Pulley Ø [mm]=141; Mounting points diam.[mm]=48; W=27.5

<b>F8-5368</b>	<b>F8-5444</b>	<b>F8-5448</b>	<b>F8-5463</b>	<b>F8-5639</b>	<b>F8-5878</b>	<b>F8-5913</b>
Ref.Nr.: 0684692	Ref.Nr.: 90473852	Ref.Nr.: 0344523	Ref.Nr.: 0344525	Ref.Nr.: 0614411	Ref.Nr.: 0344417	Ref.Nr.: 0344421
<b>F8-6217</b>	<b>F8-6494</b>	<b>F8-6517</b>	<b>F8-6733</b>	<b>F8-6734</b>	<b>F8-6755</b>	<b>F8-6835</b>
Ref.Nr.: 684168	Ref.Nr.: 0 684 697	Ref.Nr.: 90468618	Ref.Nr.: 13107328	Ref.Nr.: 302275	Ref.Nr.: 90575457	Ref.Nr.: 684694
<b>F8-6836</b>	<b>F8-6974</b>	<b>F8-7089</b>	<b>F8-7372</b>			
Ref.Nr.: 24427298	Ref.Nr.: 684249	Ref.Nr.: 5614444	Ref.Nr.: 0344591			

Article Description



Article Nr.

Fitting Position



<b>ASTRA G Hatchback (F48_, F08_)</b>		<b>02/1998 → 12/2009</b>	
Spring Cap	1.0, 1.2 16V, 1.4, 1.4 16V, 1.6, 1.6 16V, 1.7 CDTI, 1.7 DTI 16V, 1.7 TD, 1.8, 1.8 16V, 2.0 16V, 2.0 16V OPC, 2.0 DI, 2.0 DTI 16V, 2.0 OPC, 2.2 16V, 2.2 DTI	F8-7372	
Rubber Buffer, suspension	1.0, 1.2 16V, 1.4, 1.4 16V, 1.6, 1.6 16V, 1.7 CDTI, 1.7 DTI 16V, 1.7 TD, 1.8, 1.8 16V, 2.0 16V, 2.0 16V OPC, 2.0 DI, 2.0 DTI 16V, 2.0 OPC, 2.2 16V, 2.2 DTI	F8-7847	
Belt Pulley, crankshaft	1.7 TD	F8-7869	
Mounting, axle beam	1.2 16V, 1.4, 1.4 16V, 1.6, 1.6 16V, 1.7 CDTI, 1.7 DTI 16V, 1.7 TD, 1.8, 1.8 16V, 2.0 16V, 2.0 16V OPC, 2.0 DI, 2.0 DTI 16V, 2.0 OPC, 2.2 16V, 2.2 DTI	F8-7913	
Engine Mounting	1.4 16V, 1.6, 1.8, 1.8 16V	F8-8071	
Engine Mounting	1.6 16V	F8-8071	
Engine Mounting	1.6 16V	F8-8071	
Repair Kit, suspension strut	1.2 16V, 1.4, 1.4 16V, 1.6, 1.6 16V, 1.7 CDTI, 1.7 DTI 16V, 1.7 TD, 1.8, 1.8 16V, 2.0 16V, 2.0 16V OPC, 2.0 DI, 2.0 DTI 16V, 2.0 OPC, 2.2 16V, 2.2 DTI	F8-8085	
Engine Mounting	2.0 16V OPC, 2.0 DI, 2.0 DTI 16V, 2.0 OPC, 2.2 16V, 2.2 DTI	F8-8137	
Engine Mounting	1.2 16V, 1.4 16V, 1.6, 1.6 16V, 1.7 CDTI, 1.7 DTI 16V, 1.7 TD, 1.8 16V, 2.0 16V, 2.0 OPC, 2.2 DTI	F8-8142	
Engine Mounting	2.0 16V, 2.0 16V OPC	F8-8155	
Engine Mounting	2.0 DI, 2.0 DTI 16V	F8-8155	
Engine Mounting	1.2 16V, 1.4 16V, 1.6, 1.6 16V, 1.8 16V	F8-8195	
Repair Kit, suspension strut	1.2 16V, 1.4, 1.4 16V, 1.6, 1.6 16V, 1.6 LPG, 1.7 CDTI, 1.7 DTI 16V, 1.7 TD, 1.8, 1.8 16V, 2.0 16V, 2.0 16V OPC, 2.0 DI, 2.0 DTI 16V, 2.0 OPC, 2.2 16V, 2.2 DTI	F8-8214	
Bellow, steering	2.0 OPC	LM-10041S	d1=13; d2=53; L [mm]=200
<b>ASTRA G Coupe (F07_)</b>		<b>03/2000 → 05/2005</b>	
Rubber Buffer, suspension	All Models	AK-735038	
Alternator Freewheel Clutch	1.8 16V	F5-1050	
Alternator Freewheel Clutch	2.0 16V Turbo	F5-1100	
Control Arm-/Trailing Arm Bush	1.8 16V, 2.0 16V Turbo, 2.2 16V	F8-4090	H1=50; H2=59; d=12; D1=36; D2=43
Control Arm-/Trailing Arm Bush	1.8 16V, 2.0 16V Turbo, 2.2 16V	F8-5130	H=60; d=12; D=47
Engine Mounting	1.8 16V	F8-5365	Code: KZ YU;
Top Strut Mounting	All Models	F8-5448	Bearing Type: Soft Version;
Top Strut Mounting	All Models	F8-5463	
Belt Pulley, crankshaft	2.2 DTI	F8-5639	03/2003 →

<b>AK-735038</b>	<b>F5-1050</b>	<b>F5-1100</b>	<b>F8-4090</b>	<b>F8-5130</b>	<b>F8-5365</b>	<b>F8-5448</b>
Ref.Nr.: 344417	Ref.Nr.: 1204412	Ref.Nr.: 1204393	Ref.Nr.: 4566899	Ref.Nr.: 352365	Ref.Nr.: 5684045	Ref.Nr.: 0344523
<b>F8-5463</b>	<b>F8-5639</b>	<b>F8-5878</b>	<b>F8-7372</b>	<b>F8-7847</b>	<b>F8-7869</b>	<b>F8-7913</b>
Ref.Nr.: 0344525	Ref.Nr.: 0614411	Ref.Nr.: 0344417	Ref.Nr.: 0344591	Ref.Nr.: 90576351	Ref.Nr.: 5614427	Ref.Nr.: 5402638
<b>F8-8071</b>	<b>F8-8085</b>	<b>F8-8137</b>	<b>F8-8142</b>	<b>F8-8155</b>	<b>F8-8195</b>	<b>F8-8214</b>
Ref.Nr.: 684693	Ref.Nr.: 344523	Ref.Nr.: 682502	Ref.Nr.: 90538582	Ref.Nr.: 5684048	Ref.Nr.: 5684051	Ref.Nr.: 312510

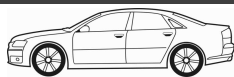
**Article Description****Article Nr.****Fitting Position**

<b>ASTRA G Coupe (F07_)</b>			<b>03/2000 → 05/2005</b>		
Rubber Buffer, suspension	1.8 16V, 2.0 16V Turbo, 2.2 16V, 2.2 DTI		<b>F8-5878</b>		H=62.5; d=24; D=50
Rubber Buffer, suspension	1.8 16V, 2.0 16V Turbo, 2.2 16V, 2.2 DTI		<b>F8-5913</b>		H=53; d=19; D=50
Engine Mounting	2.0 16V Turbo, 2.2 16V		<b>F8-6217</b>		
Rubber Buffer, suspension	All Models		<b>F8-6517</b>		
Mounting, axle beam	All Models		<b>F8-6733</b>		d=14; L=35; D1=46; D2=38.4
Mounting, axle beam	All Models		<b>F8-6734</b>		H=35.2; d=14.2; D1=45.9; D2=35.2
Engine Mounting	1.6 16V, 1.8 16V	Yellow;	<b>F8-6755</b>		
Engine Mounting	1.8 16V		<b>F8-6835</b>		
Engine Mounting	2.2 16V		<b>F8-6974</b>		
Spring Cap	All Models		<b>F8-7372</b>		
Rubber Buffer, suspension	All Models		<b>F8-7847</b>		
Mounting, axle beam	All Models		<b>F8-7913</b>		
Engine Mounting	1.6 16V, 1.8 16V		<b>F8-8071</b>		
Repair Kit, suspension strut	All Models		<b>F8-8085</b>		
Engine Mounting	2.0 16V Turbo, 2.2 16V, 2.2 DTI		<b>F8-8137</b>		
Engine Mounting	1.8 16V, 2.0 16V Turbo, 2.2 16V, 2.2 DTI		<b>F8-8142</b>		
Engine Mounting	1.8 16V		<b>F8-8195</b>		
Repair Kit, suspension strut	All Models	Bearing Type: Hard Version; ch.Y50000001, Y60000001, Y80000001→;	<b>F8-8214</b>		
Bellow, steering	1.6 16V	for steering gear manufacturer: Delphi; with clamps	<b>LM-10041S</b>		d1=13; d2=53; L [mm]=200
<b>ASTRA G Box (F70)</b>			<b>01/1999 → 04/2005</b>		
Rubber Buffer, suspension	1.6, 1.7 TD, 2.0 DI		<b>AK-735038</b>		
Alternator Freewheel Clutch	1.6		<b>F5-1050</b>		
Control Arm-/Trailing Arm Bush	1.6, 1.7 TD, 2.0 DI		<b>F8-4090</b>		H1=50; H2=59; d=12; D1=36; D2=43
Control Arm-/Trailing Arm Bush	1.6, 1.7 TD, 2.0 DI		<b>F8-5130</b>		H=60; d=12; D=47
Engine Mounting	1.6	Code: KZ YU;	<b>F8-5365</b>		
Top Strut Mounting	1.6, 1.7 TD, 2.0 DI	Bearing Type: Soft Version;	<b>F8-5448</b>		
Top Strut Mounting	1.6, 1.7 TD, 2.0 DI		<b>F8-5463</b>		
Belt Pulley, crankshaft	2.0 DI		<b>F8-5639</b>		
Rubber Buffer, suspension	1.6, 1.7 TD, 2.0 DI		<b>F8-5878</b>		H=62.5; d=24; D=50
Rubber Buffer, suspension	1.6, 1.7 TD, 2.0 DI		<b>F8-5913</b>		H=53; d=19; D=50
Rubber Buffer, suspension	1.6, 1.7 TD, 2.0 DI		<b>F8-6517</b>		

<b>AK-735038</b>	<b>F5-1050</b>	<b>F8-4090</b>	<b>F8-5130</b>	<b>F8-5365</b>	<b>F8-5448</b>	<b>F8-5463</b>
Ref.Nr.: 344417	Ref.Nr.: 1204412	Ref.Nr.: 4566899	Ref.Nr.: 352365	Ref.Nr.: 5684045	Ref.Nr.: 0344523	Ref.Nr.: 0344525
<b>F8-5639</b>	<b>F8-5878</b>	<b>F8-5913</b>	<b>F8-6217</b>	<b>F8-6517</b>	<b>F8-6733</b>	<b>F8-6734</b>
Ref.Nr.: 0614411	Ref.Nr.: 0344417	Ref.Nr.: 0344421	Ref.Nr.: 684168	Ref.Nr.: 90468618	Ref.Nr.: 13107328	Ref.Nr.: 302275
<b>F8-6755</b>	<b>F8-6835</b>	<b>F8-6974</b>	<b>F8-7372</b>	<b>F8-7847</b>	<b>F8-7913</b>	<b>F8-8071</b>
Ref.Nr.: 90575457	Ref.Nr.: 684694	Ref.Nr.: 684249	Ref.Nr.: 0344591	Ref.Nr.: 90576351	Ref.Nr.: 5402638	Ref.Nr.: 684693

Article Description



Article Nr.

Fitting Position



ASTRA G Box (F70)			01/1999 → 04/2005		
Mounting, axle beam	1.6, 1.7 TD, 2.0 DI		F8-6733		d=14; L=35; D1=46; D2=38.4
Mounting, axle beam	1.6, 1.7 TD, 2.0 DI		F8-6734		H=35.2; d=14.2; D1=45.9; D2=35.2
Engine Mounting	1.6	Yellow;	F8-6755		
Engine Mounting	1.7 TD	Yellow	F8-6755		
Spring Cap	1.6, 1.7 TD, 2.0 DI		F8-7372		
Rubber Buffer, suspension	1.6, 1.7 TD, 2.0 DI		F8-7847		
Belt Pulley, crankshaft	1.7 TD		F8-7869		
Mounting, axle beam	1.6, 1.7 TD, 2.0 DI		F8-7913		
Repair Kit, suspension strut	1.6, 1.7 TD, 2.0 DI		F8-8085		
Engine Mounting	2.0 DI		F8-8137		
Engine Mounting	1.6, 1.7 TD		F8-8142		
Engine Mounting	2.0 DI		F8-8155		
Engine Mounting	1.6		F8-8195		
Repair Kit, suspension strut	1.6, 1.7 DTI 16V, 1.7 TD, 2.0 DI	Bearing Type: Hard Version; ch.Y50000001, Y60000001, Y80000001→; ; ; not for	F8-8214		

ASTRA G Saloon (F69_)			09/1998 → 12/2009		
Rubber Buffer, suspension	1.2 16V, 1.4 16V, 1.6, 1.6 16V, 1.7 CDTI, 1.7 DTI 16V, 1.7 TD, 1.8 16V, 2.0 16V, 2.0 DI, 2.0 DTI 16V, 2.2 16V, 2.2 DTI		AK-735038		
Alternator Freewheel Clutch	1.7 CDTI		F5-1049		
Alternator Freewheel Clutch	1.4 16V, 1.6, 1.6 16V, 1.8 16V, 2.0 16V		F5-1050		
Control Arm-/Trailing Arm Bush	1.2 16V, 1.4 16V, 1.6, 1.6 16V, 1.7 DTI 16V, 1.7 TD, 1.8 16V, 2.0 16V, 2.0 DI, 2.0 DTI 16V, 2.2 16V		F8-4090		H1=50; H2=59; d=12; D1=36; D2=43
Control Arm-/Trailing Arm Bush	1.2 16V, 1.4 16V, 1.6, 1.6 16V, 1.7 DTI 16V, 1.7 TD, 1.8 16V, 2.0 16V, 2.0 DI, 2.0 DTI 16V, 2.2 16V		F8-5130		H=60; d=12; D=47
Stabiliser Mounting	1.2 16V	ch.→X2999999, X5999999	F8-5211		d=16
Stabiliser Mounting	1.2 16V	ch.Y2000001, Y5000001→	F8-5230		d=18
Stabiliser Mounting	1.4 16V, 1.6, 1.6 16V, 1.7 TD, 1.8 16V, 2.0 16V, 2.0 DI, 2.0 DTI 16V		F8-5230		d=18
Control Arm-/Trailing Arm Bush	1.2 16V, 1.4 16V, 1.6, 1.6 16V, 1.7 DTI 16V, 1.7 TD, 1.8 16V, 2.0 16V, 2.0 DI, 2.0 DTI 16V		F8-5334		d=16; D=60; Thick. [mm]=58
Engine Mounting	1.2 16V, 1.4 16V, 1.6, 1.6 16V, 1.8 16V	Code: KZ YU;	F8-5365		
Engine Mounting	1.2 16V, 1.6, 1.7 CDTI, 1.7 TD		F8-5368		
Engine Mounting	1.6, 1.7 DTI 16V		F8-5368		
Engine Mounting	1.4 16V	X 14 XE	F8-5444		
Engine Mounting	1.6, 1.6 16V		F8-5444		

<b>AK-735038</b>	<b>F5-1049</b>	<b>F5-1050</b>	<b>F8-4090</b>	<b>F8-5130</b>	<b>F8-5211</b>	<b>F8-5230</b>
Ref.Nr.: 344417	Ref.Nr.: 1204366	Ref.Nr.: 1204412	Ref.Nr.: 4566899	Ref.Nr.: 352365	Ref.Nr.: 0350130	Ref.Nr.: 0350138
<b>F8-5334</b>	<b>F8-5365</b>	<b>F8-5368</b>	<b>F8-5444</b>	<b>F8-5448</b>	<b>F8-6733</b>	<b>F8-6734</b>
Ref.Nr.: 352356	Ref.Nr.: 5684045	Ref.Nr.: 0684692	Ref.Nr.: 90473852	Ref.Nr.: 0344523	Ref.Nr.: 13107328	Ref.Nr.: 302275
<b>F8-6755</b>	<b>F8-7372</b>	<b>F8-7847</b>	<b>F8-7869</b>	<b>F8-7913</b>	<b>F8-8085</b>	<b>F8-8137</b>
Ref.Nr.: 90575457	Ref.Nr.: 0344591	Ref.Nr.: 90576351	Ref.Nr.: 5614427	Ref.Nr.: 5402638	Ref.Nr.: 344523	Ref.Nr.: 682502



**Article Description****Article Nr.****Fitting Position**

<b>ASTRA G Saloon (F69_)</b>		<b>09/1998 → 12/2009</b>	
Top Strut Mounting	1.2 16V, 1.4 16V, 1.6, 1.6 16V, 1.7 CDTI, 1.7 DTI 16V, 1.7 TD, 1.8 16V, 2.0 16V, 2.0 DI, 2.0 DTI 16V, 2.2 16V, 2.2 DTI	Bearing Type: Soft Version;	<b>F8-5448</b>
Top Strut Mounting	1.2 16V, 1.4 16V, 1.6, 1.6 16V, 1.7 CDTI, 1.7 DTI 16V, 1.7 TD, 1.8 16V, 2.0 16V, 2.0 DI, 2.0 DTI 16V, 2.2 16V, 2.2 DTI	;	<b>F8-5463</b>
Belt Pulley, crankshaft	2.0 DI, 2.0 DTI 16V, 2.2 DTI		<b>F8-5639</b>
Rubber Buffer, suspension	1.2 16V, 1.4 16V, 1.6, 1.6 16V, 1.7 DTI 16V, 1.7 TD, 1.8 16V, 2.0 16V, 2.0 DI, 2.0 DTI 16V		<b>F8-5710</b> H=46
Rubber Buffer, suspension	1.2 16V, 1.4 16V, 1.6, 1.6 16V, 1.7 CDTI, 1.7 DTI 16V, 1.7 TD, 1.8 16V, 2.0 16V, 2.0 DI, 2.0 DTI 16V, 2.2 16V, 2.2 DTI		<b>F8-5878</b> H=62.5; d=24; D=50
Rubber Buffer, suspension	1.2 16V, 1.4 16V, 1.6, 1.6 16V, 1.7 CDTI, 1.7 DTI 16V, 1.7 TD, 1.8 16V, 2.0 16V, 2.0 DI, 2.0 DTI 16V, 2.2 16V, 2.2 DTI		<b>F8-5913</b> H=53; d=19; D=50
Engine Mounting	2.2 16V		<b>F8-6217</b>
Engine Mounting	2.0 DI, 2.0 DTI 16V		<b>F8-6494</b>
Rubber Buffer, suspension	1.2 16V, 1.4, 1.4 16V, 1.6, 1.6 16V, 1.7 CDTI, 1.7 DTI 16V, 1.7 TD, 1.8 16V, 2.0 16V, 2.0 DI, 2.0 DTI 16V, 2.2 16V, 2.2 DTI		<b>F8-6517</b>
Sleeve, control arm mounting	1.6 16V		<b>F8-6656</b>
Mounting, axle beam	1.2 16V, 1.4, 1.4 16V, 1.6, 1.6 16V, 1.7 CDTI, 1.7 DTI 16V, 1.7 TD, 1.8 16V, 2.0 16V, 2.0 DI, 2.0 DTI 16V, 2.2 16V, 2.2 DTI		<b>F8-6733</b> d=14; L=35; D1=46; D2=38.4
Mounting, axle beam	1.2 16V, 1.4, 1.4 16V, 1.6, 1.6 16V, 1.7 CDTI, 1.7 DTI 16V, 1.7 TD, 1.8 16V, 2.0 16V, 2.0 DI, 2.0 DTI 16V, 2.2 16V, 2.2 DTI		<b>F8-6734</b> H=35.2; d=14.2; D1=45.9; D2=35.2
Engine Mounting	1.4 16V, 1.6, 1.6 16V, 1.8 16V	Yellow;	<b>F8-6755</b>
Engine Mounting	1.7 CDTI, 1.7 DTI 16V, 1.7 TD	Yellow	<b>F8-6755</b>
Engine Mounting	1.4 16V, 1.6, 1.6 16V, 1.8 16V		<b>F8-6835</b>
Engine Mounting	1.7 CDTI	Engine →30231947, 35023929, 38000636	<b>F8-6836</b>
Engine Mounting	1.7 DTI 16V, 1.7 TD		<b>F8-6836</b>
Engine Mounting	2.0 DI, 2.0 DTI 16V	ch.32000001, 35000001, 36000001, 38000001, 3B000001, 3H000001, 4G000001→	<b>F8-6836</b>
Engine Mounting	2.2 16V		<b>F8-6974</b>
Belt Pulley, crankshaft	1.7 CDTI, 1.7 DTI 16V	Number of Ribs: 6	<b>F8-7089</b>
Spring Cap	1.2 16V, 1.4, 1.4 16V, 1.6, 1.6 16V, 1.7 CDTI, 1.7 DTI 16V, 1.7 TD, 1.8 16V, 2.0 16V, 2.0 DI, 2.0 DTI 16V, 2.2 16V, 2.2 DTI		<b>F8-7372</b>

<b>F8-5448</b>	<b>F8-5463</b>	<b>F8-5639</b>	<b>F8-5710</b>	<b>F8-5878</b>	<b>F8-5913</b>	<b>F8-6217</b>
Ref.Nr.: 0344523	Ref.Nr.: 0344525	Ref.Nr.: 0614411	Ref.Nr.: 0344402	Ref.Nr.: 0344417	Ref.Nr.: 0344421	Ref.Nr.: 684168
<b>F8-6494</b>	<b>F8-6517</b>	<b>F8-6656</b>	<b>F8-6733</b>	<b>F8-6734</b>	<b>F8-6755</b>	<b>F8-6835</b>
Ref.Nr.: 0 684 697	Ref.Nr.: 90468618	Ref.Nr.: 4246062	Ref.Nr.: 13107328	Ref.Nr.: 302275	Ref.Nr.: 90575457	Ref.Nr.: 684694
<b>F8-6836</b>	<b>F8-6974</b>	<b>F8-7089</b>	<b>F8-7372</b>	<b>F8-7847</b>		
Ref.Nr.: 24427298	Ref.Nr.: 684249	Ref.Nr.: 5614444	Ref.Nr.: 0344591	Ref.Nr.: 90576351		

Article Description



Article Nr.

Fitting Position



<b>ASTRA G Saloon (F69)</b>		<b>09/1998 → 12/2009</b>	
Rubber Buffer, suspension	1.2 16V, 1.4, 1.4 16V, 1.6, 1.6 16V, 1.6 LPG, 1.7 CDTI, 1.7 DTI 16V, 1.7 TD, 1.8 16V, 2.0 16V, 2.0 DI, 2.0 DTI 16V, 2.2 16V, 2.2 DTI	F8-7847	
Belt Pulley, crankshaft	1.7 TD	F8-7869	
Mounting, axle beam	1.2 16V, 1.4, 1.4 16V, 1.6, 1.6 16V, 1.7 CDTI, 1.7 DTI 16V, 1.7 TD, 1.8 16V, 2.0 16V, 2.0 DI, 2.0 DTI 16V, 2.2 16V, 2.2 DTI	F8-7913	
Engine Mounting	1.4 16V, 1.6, 1.6 16V, 1.8 16V	F8-8071	
Repair Kit, suspension strut	All Models	F8-8085	
Engine Mounting	2.0 DI, 2.0 DTI 16V, 2.2 16V, 2.2 DTI	F8-8137	
Engine Mounting	1.2 16V, 1.4 16V, 1.6, 1.6 16V, 1.7 CDTI, 1.7 DTI 16V, 1.7 TD, 1.8 16V, 2.0 16V, 2.2 DTI	F8-8142	
Engine Mounting	2.0 16V	F8-8155	
Engine Mounting	2.0 DI, 2.0 DTI 16V	F8-8155	
Engine Mounting	1.2 16V, 1.4 16V, 1.6, 1.6 16V, 1.8 16V	F8-8195	
Repair Kit, suspension strut	1.2 16V, 1.4, 1.4 16V, 1.6, 1.6 16V, 1.6 LPG, 1.7 CDTI, 1.7 DTI 16V, 1.7 TD, 1.8 16V, 2.0 16V, 2.0 DI, 2.0 DTI 16V, 2.2 16V, 2.2 DTI	F8-8214	
		Bearing Type: Hard Version; ch.Y50000001, Y60000001, Y80000001→;   ; not for	
<b>ASTRA H (L48)</b>		<b>03/2004 → 10/2004</b>	
Dust Cover Kit, shock absorber	1.2, 1.3 CDTI, 1.4, 1.6, 1.6 Turbo, 1.7 CDTI, 1.8, 1.9 CDTI, 1.9 CDTI 16V, 2.0 Turbo	AK-735251	
Dust Cover Kit, shock absorber	1.2, 1.3 CDTI, 1.4, 1.6, 1.6 Turbo, 1.7 CDTI, 1.8, 1.9 CDTI, 1.9 CDTI 16V, 2.0 Turbo	AK-735252	
Alternator Freewheel Clutch	1.2, 1.3 CDTI, 1.4, 1.4 LPG	F5-1041	
Alternator Freewheel Clutch	1.2, 1.3 CDTI, 1.4, 1.4 LPG	F5-1045	
Alternator Freewheel Clutch	1.7 CDTI	F5-1049	
Alternator Freewheel Clutch	2.0 Turbo	F5-1100	
Alternator Freewheel Clutch	1.9 CDTI, 1.9 CDTI 16V	F5-1102	
Alternator Freewheel Clutch	1.9 CDTI, 1.9 CDTI 16V	F5-1123	
Control Arm-/Trailing Arm Bush	1.4, 1.6, 1.7 CDTI, 1.8	F8-4090	H1=50; H2=59; d=12; D1=36; D2=43
Engine Mounting	1.7 CDTI	F8-6657	
Mounting, axle beam	1.2, 1.3 CDTI, 1.4, 1.6, 1.6 Turbo, 1.7 CDTI, 1.8, 1.9 CDTI, 1.9 CDTI 16V, 2.0 Turbo	F8-6733	d=14; L=35; D1=46; D2=38.4
Mounting, axle beam	1.2, 1.3 CDTI, 1.4, 1.6, 1.6 Turbo, 1.7 CDTI, 1.8, 1.9 CDTI, 1.9 CDTI 16V, 2.0 Turbo	F8-6734	H=35.2; d=14.2; D1=45.9; D2=35.2
Engine Mounting	1.7 CDTI	F8-6836	
Engine Mounting	1.9 CDTI, 1.9 CDTI 16V	F8-6836	
Engine Mounting	1.2, 1.4, 1.6	F8-6975	Code: KZ JE
Engine Mounting	1.8	F8-6975	Code: KZ JE;

<b>AK-735251</b>	<b>AK-735252</b>	<b>F5-1041</b>	<b>F5-1045</b>	<b>F5-1049</b>	<b>F5-1100</b>	<b>F5-1102</b>
Ref.Nr.: 344435	Ref.Nr.: 344416	Ref.Nr.: 77364723	Ref.Nr.: 77362721	Ref.Nr.: 1204366	Ref.Nr.: 1204393	Ref.Nr.: 1204151
<b>F5-1123</b>	<b>F8-4090</b>	<b>F8-6657</b>	<b>F8-6733</b>	<b>F8-6734</b>	<b>F8-6836</b>	<b>F8-6975</b>
Ref.Nr.: 9948513	Ref.Nr.: 4566899	Ref.Nr.: 5684134	Ref.Nr.: 13107328	Ref.Nr.: 302275	Ref.Nr.: 24427298	Ref.Nr.: 24459803
<b>F8-6977</b>	<b>F8-7847</b>	<b>F8-7869</b>	<b>F8-7913</b>	<b>F8-8071</b>	<b>F8-8085</b>	<b>F8-8137</b>
Ref.Nr.: 24459797	Ref.Nr.: 90576351	Ref.Nr.: 5614427	Ref.Nr.: 5402638	Ref.Nr.: 684693	Ref.Nr.: 344523	Ref.Nr.: 682502

**Article Description****Article Nr.****Fitting Position**

<b>ASTRA H (L48)</b>			<b>03/2004 → 10/2004</b>		
Engine Mounting	2.0 Turbo		<b>F8-6977</b>		
Engine Mounting	1.7 CDTI		<b>F8-6978</b>		
Engine Mounting	1.2, 1.3 CDTI, 1.4, 1.6, 1.6 Turbo, 1.8	Code: KZ KD	<b>F8-6980</b>	⊕	
Engine Mounting	1.6		<b>F8-6981</b>	⊕	
Engine Mounting	1.3 CDTI, 1.7 CDTI		<b>F8-6982</b>	⊕	
Engine Mounting	1.8		<b>F8-6982</b>	⊕	
Engine Mounting	1.7 CDTI, 2.0 Turbo		<b>F8-6983</b>	⊕	
Engine Mounting	1.8		<b>F8-6983</b>	⊕	
Engine Mounting	1.7 CDTI	Code: KZ KA;	<b>F8-6984</b>	⊕	
Engine Mounting	1.7 CDTI	Code: KZ KA;  Z 17 DTJ;	<b>F8-6984</b>	⊕	
Engine Mounting	1.7 CDTI	Code: KZ KA;  Z 17 DTR;	<b>F8-6984</b>	⊕	
Engine Mounting	1.9 CDTI, 1.9 CDTI 16V	Code: KZ KA;	<b>F8-6984</b>	⊕	
Engine Mounting	1.9 CDTI, 1.9 CDTI 16V	Code: KB;	<b>F8-6985</b>	⊕	
Anti-Friction Bearing	1.2, 1.3 CDTI, 1.4, 1.6, 1.6 Turbo, 1.7 CDTI, 1.8, 1.9 CDTI, 1.9 CDTI 16V, 2.0 Turbo		<b>F8-7172</b>	⊕ ⊕	
Top Strut Mounting	1.2, 1.3 CDTI, 1.4, 1.6, 1.6 Turbo, 1.7 CDTI, 1.8, 1.9 CDTI, 1.9 CDTI 16V, 2.0 Turbo	Additionally required articles: F8-7625;	<b>F8-7327</b>	⊕ ⊕	
Top Strut Mounting	1.2, 1.3 CDTI, 1.4, 1.6, 1.6 Turbo, 1.7 CDTI, 1.8, 1.9 CDTI, 1.9 CDTI 16V, 2.0 Turbo		<b>F8-7328</b>	⊕ ⊕	
Top Strut Mounting	1.2, 1.3 CDTI, 1.4, 1.6, 1.6 Turbo, 1.7 CDTI, 1.8, 1.9 CDTI, 1.9 CDTI 16V, 2.0 Turbo		<b>F8-7328S</b>	⊕ ⊕	
Mounting Kit, shock absorber	All Models	for article nr: A-3246GL & A-3246GR, F8-7327	<b>F8-7625</b>	⊕ ⊕	
Rubber Buffer, suspension	1.2, 1.3 CDTI, 1.4, 1.4 LPG, 1.6, 1.6 Turbo, 1.7 CDTI, 1.8, 1.9 CDTI, 1.9 CDTI 16V, 2.0 Turbo	ch.52000001, 55000001, 58000001, 8B000001→;	<b>F8-7662</b>	⊕ ⊕	H=40
Protective Cap/Bellow, shock absorber	1.2, 1.3 CDTI, 1.4, 1.4 LPG, 1.6, 1.6 Turbo, 1.7 CDTI, 1.8, 1.9 CDTI, 1.9 CDTI 16V, 2.0 Turbo		<b>F8-7663</b>	⊕ ⊕	H=205
Rubber Buffer, suspension	1.2, 1.3 CDTI, 1.4, 1.6, 1.6 Turbo, 1.7 CDTI, 1.8, 1.9 CDTI, 1.9 CDTI 16V, 2.0 Turbo	ch.→4299999, 4599999, 4899999; ;	<b>F8-7699</b>	⊕ ⊕	H=50
Rubber Buffer, suspension	1.2, 1.3 CDTI, 1.4, 1.6, 1.6 Turbo, 1.7 CDTI, 1.8, 1.9 CDTI, 1.9 CDTI 16V, 2.0 Turbo	ch.52000001, 55000001, 58000001→;	<b>F8-7699</b>	⊕ ⊕	H=50
Rubber Buffer, suspension	1.4 LPG	ch.→4299999, 4599999, 4899999	<b>F8-7699</b>	⊕ ⊕	H=50
Rubber Buffer, suspension	1.4 LPG	ch.52000001, 55000001, 58000001, 8B000001→;	<b>F8-7699</b>	⊕ ⊕	H=50
Rubber Buffer, suspension	1.2, 1.3 CDTI, 1.4, 1.4 LPG, 1.6, 1.6 Turbo, 1.7 CDTI, 1.8, 1.9 CDTI, 1.9 CDTI 16V, 2.0 Turbo		<b>F8-7847</b>	⊕ ⊕ ⊕ ↑	
Belt Pulley, crankshaft	1.7 CDTI	Number of Ribs: 5; Parameter: 6PK	<b>F8-7872</b>		Belt Pulley Ø [mm]=149; H1=22; H2=32
Stabiliser Mounting	1.2, 1.3 CDTI, 1.4, 1.4 LPG, 1.6, 1.6 Turbo, 1.7 CDTI, 1.8, 1.9 CDTI, 1.9 CDTI 16V, 2.0 Turbo	ch.→52999999, 55999999, 58999999	<b>F8-7926</b>	⊕ ⊕	d=21

<b>F8-6977</b>	<b>F8-6978</b>	<b>F8-6980</b>	<b>F8-6981</b>	<b>F8-6982</b>	<b>F8-6983</b>	<b>F8-6984</b>
Ref.Nr.: 24459797	Ref.Nr.: 5684130	Ref.Nr.: 13125637	Ref.Nr.: 13159994	Ref.Nr.: 13159995	Ref.Nr.: 13159996	Ref.Nr.: 13159997
<b>F8-6985</b>	<b>F8-7172</b>	<b>F8-7327</b>	<b>F8-7328</b>	<b>F8-7328S</b>	<b>F8-7625</b>	<b>F8-7662</b>
Ref.Nr.: 13159998	Ref.Nr.: 9191181	Ref.Nr.: 13186960	Ref.Nr.: 13270705	Ref.Nr.: 344625	Ref.Nr.: 24402155	Ref.Nr.: 0344956
<b>F8-7663</b>	<b>F8-7699</b>	<b>F8-7847</b>	<b>F8-7872</b>	<b>F8-7926</b>	<b>F8-7944</b>	
Ref.Nr.: 344435	Ref.Nr.: 13117280	Ref.Nr.: 90576351	Ref.Nr.: 614758	Ref.Nr.: 350161	Ref.Nr.: 402 952	

Article Description



Article Nr.

Fitting Position



<b>ASTRA H (L48)</b>		<b>03/2004 → 10/2004</b>	
Mounting, axle beam	1.2, 1.3 CDTI, 1.4, 1.6, 1.6 Turbo, 1.7 CDTI, 1.8, 1.9 CDTI, 1.9 CDTI 16V, 2.0 Turbo		F8-7944    d=13
Mounting, axle beam	1.6	Z 16 XER	F8-7944    d=13
Mounting, axle beam	1.7 CDTI	Z 17 DTJ	F8-7944    d=13
Mounting, axle beam	1.7 CDTI	Z 17 DTR	F8-7944    d=13
Mounting, axle beam	1.8	Z 18 XER	F8-7944    d=13
Control Arm-/Trailing Arm Bush	1.3 CDTI, 1.4, 1.6, 1.6 Turbo, 1.7 CDTI, 1.8, 1.9 CDTI, 1.9 CDTI 16V, 2.0 Turbo		F8-7946
Engine Mounting	1.2, 1.3 CDTI, 1.4, 1.6, 1.6 Turbo, 1.7 CDTI, 1.8, 1.9 CDTI, 1.9 CDTI 16V, 2.0 Turbo		F8-8137
Engine Mounting	1.2, 1.3 CDTI, 1.4, 1.6, 1.8		F8-8142

<b>ASTRA H Estate (L35)</b>		<b>08/2004 →</b>	
Dust Cover Kit, shock absorber	1.3 CDTI, 1.4, 1.6, 1.6 Turbo, 1.7 CDTI, 1.8, 1.9 CDTI, 1.9 CDTI 16V, 2.0 Turbo	<b>ST</b>	AK-735251
Dust Cover Kit, shock absorber	1.3 CDTI, 1.4, 1.6, 1.6 Turbo, 1.7 CDTI, 1.8, 1.9 CDTI, 1.9 CDTI 16V, 2.0 Turbo	<b>SP</b>	AK-735252
Alternator Freewheel Clutch	1.3 CDTI, 1.4, 1.4 LPG		F5-1041
Alternator Freewheel Clutch	1.3 CDTI, 1.4, 1.4 LPG		F5-1045
Alternator Freewheel Clutch	1.7 CDTI		F5-1049
Alternator Freewheel Clutch	2.0 Turbo		F5-1100
Alternator Freewheel Clutch	1.9 CDTI, 1.9 CDTI 16V		F5-1102
Alternator Freewheel Clutch	1.9 CDTI, 1.9 CDTI 16V		F5-1123
Engine Mounting	1.7 CDTI		F8-6657
Mounting, axle beam	1.3 CDTI, 1.4, 1.6, 1.6 Turbo, 1.7 CDTI, 1.8, 1.9 CDTI, 1.9 CDTI 16V, 2.0 Turbo		F8-6733    d=14; L=35; D1=46; D2=38.4
Mounting, axle beam	1.3 CDTI, 1.4, 1.6, 1.6 Turbo, 1.7 CDTI, 1.8, 1.9 CDTI, 1.9 CDTI 16V, 2.0 Turbo		F8-6734    H=35.2; d=14.2; D1=45.9; D2=35.2
Engine Mounting	1.7 CDTI		F8-6836
Engine Mounting	1.9 CDTI, 1.9 CDTI 16V		F8-6836
Engine Mounting	1.4, 1.6	Code: KZ JE	F8-6975
Engine Mounting	1.8	Code: KZ JE;	F8-6975
Engine Mounting	2.0 Turbo		F8-6977
Engine Mounting	1.7 CDTI		F8-6978
Engine Mounting	1.3 CDTI, 1.4, 1.6, 1.6 Turbo, 1.8	Code: KZ KD	F8-6980
Engine Mounting	1.6		F8-6981
Engine Mounting	1.3 CDTI, 1.7 CDTI		F8-6982
Engine Mounting	1.8		F8-6982
Engine Mounting	1.7 CDTI, 2.0 Turbo		F8-6983

<b>AK-735251</b>	<b>AK-735252</b>	<b>F5-1041</b>	<b>F5-1045</b>	<b>F5-1049</b>	<b>F5-1100</b>	<b>F5-1102</b>
Ref.Nr.: 344435	Ref.Nr.: 344416	Ref.Nr.: 77364723	Ref.Nr.: 77362721	Ref.Nr.: 1204366	Ref.Nr.: 1204393	Ref.Nr.: 1204151
<b>F5-1123</b>	<b>F8-6657</b>	<b>F8-6733</b>	<b>F8-6734</b>	<b>F8-6836</b>	<b>F8-6975</b>	<b>F8-6977</b>
Ref.Nr.: 9948513	Ref.Nr.: 5684134	Ref.Nr.: 13107328	Ref.Nr.: 302275	Ref.Nr.: 24427298	Ref.Nr.: 24459803	Ref.Nr.: 24459797
<b>F8-6978</b>	<b>F8-6980</b>	<b>F8-6981</b>	<b>F8-6982</b>	<b>F8-6983</b>	<b>F8-7944</b>	<b>F8-7946</b>
Ref.Nr.: 5684130	Ref.Nr.: 13125637	Ref.Nr.: 13159994	Ref.Nr.: 13159995	Ref.Nr.: 13159996	Ref.Nr.: 402 952	Ref.Nr.: 352324

**Article Description****Article Nr.****Fitting Position**

<b>ASTRA H Estate (L35)</b>				<b>08/2004 →</b>	
Engine Mounting	1.8		<b>F8-6983</b>		
Engine Mounting	1.7 CDTI	Code: KZ KA;	<b>F8-6984</b>		
Engine Mounting	1.7 CDTI	Code: KZ KA;  A 17 DTR;	<b>F8-6984</b>		
Engine Mounting	1.9 CDTI, 1.9 CDTI 16V	Code: KZ KA;	<b>F8-6984</b>		
Engine Mounting	1.9 CDTI, 1.9 CDTI 16V	Code: KB;	<b>F8-6985</b>		
Anti-Friction Bearing	1.3 CDTI, 1.4, 1.6, 1.6 Turbo, 1.7 CDTI, 1.8, 1.9 CDTI, 1.9 CDTI 16V, 2.0 Turbo		<b>F8-7172</b>		
Top Strut Mounting	1.3 CDTI, 1.4, 1.6, 1.6 Turbo, 1.7 CDTI, 1.8, 1.9 CDTI, 1.9 CDTI 16V, 2.0 Turbo	Additionally required articles: F8-7625;	<b>F8-7327</b>		
Top Strut Mounting	1.3 CDTI, 1.4, 1.6, 1.6 Turbo, 1.7 CDTI, 1.8, 1.9 CDTI, 1.9 CDTI 16V, 2.0 Turbo		<b>F8-7328</b>		
Top Strut Mounting	1.3 CDTI, 1.4, 1.6, 1.6 Turbo, 1.7 CDTI, 1.8, 1.9 CDTI, 1.9 CDTI 16V, 2.0 Turbo		<b>F8-7328S</b>		
Mounting Kit, shock absorber	All Models	for article nr: A-3246GL & A-3246GR, F8-7327	<b>F8-7625</b>		
Rubber Buffer, suspension	1.3 CDTI, 1.4, 1.4 LPG, 1.6, 1.6 Turbo, 1.7 CDTI, 1.8, 1.9 CDTI, 1.9 CDTI 16V, 2.0 Turbo	ch.52000001, 55000001, 58000001, 8B000001 →;	<b>F8-7662</b>		H=40
Protective Cap/Bellow, shock absorber	1.3 CDTI, 1.4, 1.4 LPG, 1.6, 1.6 LPG, 1.6 Turbo, 1.7 CDTI, 1.8, 1.9 CDTI, 1.9 CDTI 16V, 2.0 Turbo		<b>F8-7663</b>		H=205
Rubber Buffer, suspension	1.3 CDTI, 1.4, 1.6, 1.6 Turbo, 1.7 CDTI, 1.8, 1.9 CDTI, 1.9 CDTI 16V, 2.0 Turbo	ch.→4299999, 4599999, 4899999;	<b>F8-7699</b>		H=50
Rubber Buffer, suspension	1.3 CDTI, 1.4, 1.6, 1.6 Turbo, 1.7 CDTI, 1.8, 1.9 CDTI, 1.9 CDTI 16V, 2.0 Turbo	ch.52000001, 55000001, 58000001 →;	<b>F8-7699</b>		H=50
Rubber Buffer, suspension	1.4, 1.4 LPG, 1.6 LPG	ch.→4299999, 4599999, 4899999	<b>F8-7699</b>		H=50
Rubber Buffer, suspension	1.4, 1.4 LPG, 1.6 LPG	ch.52000001, 55000001, 58000001, 8B000001 →;	<b>F8-7699</b>		H=50
Rubber Buffer, suspension	1.3 CDTI, 1.4, 1.4 LPG, 1.6, 1.6 LPG, 1.6 Turbo, 1.7 CDTI, 1.8, 1.9 CDTI, 1.9 CDTI 16V, 2.0 Turbo		<b>F8-7847</b>		
Belt Pulley, crankshaft	1.7 CDTI	Number of Ribs: 5; Parameter: 6PK	<b>F8-7872</b>		Belt Pulley Ø [mm]=149; H1=22; H2=32
Mounting, axle beam	1.3 CDTI, 1.4, 1.6, 1.6 Turbo, 1.7 CDTI, 1.8, 1.9 CDTI, 1.9 CDTI 16V, 2.0 Turbo		<b>F8-7944</b>		d=13
Mounting, axle beam	1.7 CDTI	A 17 DTR	<b>F8-7944</b>		d=13
Control Arm-/Trailing Arm Bush	1.3 CDTI, 1.4, 1.4 LPG, 1.6, 1.6 LPG, 1.6 Turbo, 1.7 CDTI, 1.8, 1.9 CDTI, 1.9 CDTI 16V, 2.0 Turbo		<b>F8-7946</b>		
Engine Mounting	1.3 CDTI, 1.4, 1.6, 1.6 Turbo, 1.7 CDTI, 1.8, 1.9 CDTI, 1.9 CDTI 16V, 2.0 Turbo		<b>F8-8137</b>		
Engine Mounting	1.3 CDTI, 1.4, 1.6, 1.8		<b>F8-8142</b>		
<b>ASTRA H Sport Hatch (L08)</b>				<b>03/2005 →</b>	
Dust Cover Kit, shock absorber	All Models		<b>AK-735251</b>		
Dust Cover Kit, shock absorber	1.2, 1.3 CDTI, 1.4, 1.6, 1.6 Turbo, 1.7 CDTI, 1.8, 1.9 CDTI, 1.9 CDTI 16V, 2.0 Turbo		<b>AK-735252</b>		

<b>AK-735251</b>	<b>AK-735252</b>	<b>F5-1041</b>	<b>F8-6983</b>	<b>F8-6984</b>	<b>F8-6985</b>	<b>F8-7172</b>
Ref.Nr.: 344435	Ref.Nr.: 344416	Ref.Nr.: 77364723	Ref.Nr.: 13159996	Ref.Nr.: 13159997	Ref.Nr.: 13159998	Ref.Nr.: 9191181
<b>F8-7327</b>	<b>F8-7328</b>	<b>F8-7328S</b>	<b>F8-7625</b>	<b>F8-7662</b>	<b>F8-7663</b>	<b>F8-7699</b>
Ref.Nr.: 13186960	Ref.Nr.: 13270705	Ref.Nr.: 344625	Ref.Nr.: 24402155	Ref.Nr.: 0344956	Ref.Nr.: 344435	Ref.Nr.: 13117280
<b>F8-7847</b>	<b>F8-7872</b>	<b>F8-7944</b>	<b>F8-7946</b>	<b>F8-8137</b>	<b>F8-8142</b>	
Ref.Nr.: 90576351	Ref.Nr.: 614758	Ref.Nr.: 402 952	Ref.Nr.: 352324	Ref.Nr.: 682502	Ref.Nr.: 90538582	

Article Description

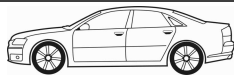

Article Nr.

Fitting Position



**ASTRA H Sport Hatch (L08)**

03/2005 →

Alternator Freewheel Clutch	1.2, 1.3 CDTI, 1.4		<b>F5-1041</b>		
Alternator Freewheel Clutch	1.2, 1.3 CDTI, 1.4		<b>F5-1045</b>		
Alternator Freewheel Clutch	1.7 CDTI		<b>F5-1049</b>		
Alternator Freewheel Clutch	2.0 Turbo		<b>F5-1100</b>		
Alternator Freewheel Clutch	1.9 CDTI, 1.9 CDTi 16V		<b>F5-1102</b>		
Alternator Freewheel Clutch	1.9 CDTI, 1.9 CDTi 16V		<b>F5-1123</b>		
Mounting, axle beam	1.2, 1.3 CDTI, 1.4, 1.6, 1.6 Turbo, 1.7 CDTI, 1.8, 1.9 CDTI, 1.9 CDTi 16V, 2.0 Turbo		<b>F8-6733</b>		d=14; L=35; D1=46; D2=38.4
Mounting, axle beam	1.2, 1.3 CDTI, 1.4, 1.6, 1.6 Turbo, 1.7 CDTI, 1.8, 1.9 CDTI, 1.9 CDTi 16V, 2.0 Turbo		<b>F8-6734</b>		H=35.2; d=14.2; D1=45.9; D2=35.2
Engine Mounting	1.7 CDTI		<b>F8-6836</b>		
Engine Mounting	1.9 CDTI, 1.9 CDTi 16V		<b>F8-6836</b>		
Engine Mounting	1.2, 1.4, 1.6	Code: KZ JE	<b>F8-6975</b>		
Engine Mounting	1.8	Code: KZ JE;	<b>F8-6975</b>		
Engine Mounting	2.0 Turbo		<b>F8-6977</b>		
Engine Mounting	1.7 CDTi		<b>F8-6978</b>		
Engine Mounting	1.2, 1.3 CDTI, 1.4, 1.6, 1.6 Turbo, 1.8	Code: KZ KD	<b>F8-6980</b>		
Engine Mounting	1.6		<b>F8-6981</b>		
Engine Mounting	1.8		<b>F8-6982</b>		
Engine Mounting	1.7 CDTi, 2.0 Turbo		<b>F8-6983</b>		
Engine Mounting	1.8		<b>F8-6983</b>		
Engine Mounting	1.7 CDTI	Code: KZ KA;	<b>F8-6984</b>		
Engine Mounting	1.9 CDTi, 1.9 CDTi 16V	Code: KZ KA;	<b>F8-6984</b>		
Engine Mounting	1.9 CDTi, 1.9 CDTi 16V	Code: KB;	<b>F8-6985</b>		
Anti-Friction Bearing	All Models		<b>F8-7172</b>		
Top Strut Mounting	All Models	Additionally required articles: F8-7625;	<b>F8-7327</b>		
Top Strut Mounting	All Models		<b>F8-7328</b>		
Top Strut Mounting	All Models		<b>F8-7328S</b>		
Mounting Kit, shock absorber	All Models	for article nr: A-3246GL & A-3246GR, F8-7327	<b>F8-7625</b>		
Rubber Buffer, suspension	1.2, 1.3 CDTI, 1.4, 1.6, 1.6 Turbo, 1.7 CDTI, 1.8, 1.9 CDTI, 1.9 CDTi 16V, 2.0 Turbo	ch.52000001, 55000001, 58000001, 8B000001→;	<b>F8-7662</b>		H=40
Protective Cap/Bellow, shock absorber	1.2, 1.3 CDTI, 1.4, 1.6, 1.6 Turbo, 1.7 CDTI, 1.8, 1.9 CDTI, 1.9 CDTi 16V, 2.0 Turbo		<b>F8-7663</b>		H=205
Rubber Buffer, suspension	1.2, 1.3 CDTI, 1.4, 1.6, 1.6 Turbo, 1.7 CDTI, 1.8, 1.9 CDTI, 1.9 CDTi 16V, 2.0 Turbo	ch.→4299999, 4599999, 4899999;	<b>F8-7699</b>		H=50
Rubber Buffer, suspension	1.2, 1.3 CDTI, 1.4, 1.6, 1.6 Turbo, 1.7 CDTI, 1.8, 1.9 CDTI, 1.9 CDTi 16V, 2.0 Turbo	ch.52000001, 55000001, 58000001→;	<b>F8-7699</b>		H=50

<b>F5-1041</b>	<b>F5-1045</b>	<b>F5-1049</b>	<b>F5-1100</b>	<b>F5-1102</b>	<b>F5-1123</b>	<b>F8-6733</b>
Ref.Nr.: 77364723	Ref.Nr.: 77362721	Ref.Nr.: 1204366	Ref.Nr.: 1204393	Ref.Nr.: 1204151	Ref.Nr.: 9948513	Ref.Nr.: 13107328
<b>F8-6734</b>	<b>F8-6836</b>	<b>F8-6975</b>	<b>F8-6977</b>	<b>F8-6978</b>	<b>F8-6980</b>	<b>F8-6981</b>
Ref.Nr.: 302275	Ref.Nr.: 24427298	Ref.Nr.: 24459803	Ref.Nr.: 24459797	Ref.Nr.: 5684130	Ref.Nr.: 13125637	Ref.Nr.: 13159994
<b>F8-6982</b>	<b>F8-6983</b>	<b>F8-6984</b>	<b>F8-6985</b>	<b>F8-7172</b>	<b>F8-7327</b>	<b>F8-7328</b>
Ref.Nr.: 13159995	Ref.Nr.: 13159996	Ref.Nr.: 13159997	Ref.Nr.: 13159998	Ref.Nr.: 9191181	Ref.Nr.: 13186960	Ref.Nr.: 13270705

**Article Description****Article Nr.****Fitting Position**

<b>ASTRA H Sport Hatch (L08)</b>				<b>03/2005 →</b>	
Rubber Buffer, suspension	1.4, 1.7 CDTi	ch.→4299999, 4599999, 4899999	<b>F8-7699</b>		H=50
Rubber Buffer, suspension	1.4, 1.7 CDTi	ch.52000001, 55000001, 58000001, 8B000001→;	<b>F8-7699</b>		H=50
Rubber Buffer, suspension	1.2, 1.3 CDTi, 1.4, 1.6, 1.6 Turbo, 1.7 CDTi, 1.8, 1.9 CDTi, 1.9 CDTi 16V, 2.0 Turbo		<b>F8-7847</b>		
Belt Pulley, crankshaft	1.7 CDTi	Number of Ribs: 5; Parameter: 6PK	<b>F8-7872</b>		Belt Pulley Ø [mm]=149; H1=22; H2=32
Stabiliser Mounting	1.2, 1.3 CDTi, 1.4, 1.6, 1.6 Turbo, 1.7 CDTi, 1.8, 1.9 CDTi, 1.9 CDTi 16V, 2.0 Turbo	ch.→52999999, 55999999, 58999999	<b>F8-7926</b>		d=21
Mounting, axle beam	1.2, 1.3 CDTi, 1.4, 1.6, 1.6 Turbo, 1.7 CDTi, 1.8, 1.9 CDTi, 1.9 CDTi 16V, 2.0 Turbo		<b>F8-7944</b>		d=13
Control Arm-/Trailing Arm Bush	1.3 CDTi, 1.4, 1.6, 1.6 Turbo, 1.7 CDTi, 1.8, 1.9 CDTi, 1.9 CDTi 16V, 2.0 Turbo		<b>F8-7946</b>		
Engine Mounting	1.2, 1.4, 1.6, 1.6 Turbo, 1.7 CDTi, 1.8, 1.9 CDTi, 1.9 CDTi 16V, 2.0 Turbo		<b>F8-8137</b>		
Engine Mounting	1.2, 1.3 CDTi, 1.4, 1.6, 1.8		<b>F8-8142</b>		
<b>ASTRA H Saloon (L69)</b>				<b>02/2007 →</b>	
Alternator Freewheel Clutch	1.3 CDTi		<b>F5-1041</b>		
Alternator Freewheel Clutch	1.3 CDTi		<b>F5-1045</b>		
Alternator Freewheel Clutch	1.7 CDTi		<b>F5-1049</b>		
Mounting, axle beam	1.3 CDTi, 1.6, 1.8		<b>F8-6733</b>		d=14; L=35; D1=46; D2=38.4
Mounting, axle beam	1.3 CDTi, 1.6, 1.8		<b>F8-6734</b>		H=35.2; d=14.2; D1=45.9; D2=35.2
Engine Mounting	1.6	Code: KZ JE	<b>F8-6975</b>		
Engine Mounting	1.8	Code: KZ JE; Transmission Type: Easytronic	<b>F8-6975</b>		
Engine Mounting	1.8	Code: KZ JE;	<b>F8-6975</b>		
Engine Mounting	1.3 CDTi, 1.6	Code: KZ KD	<b>F8-6980</b>		
Engine Mounting	1.8	ch.→82138052, 85097612, 88081332, 8G125960; Code: KZ KD; Transmission Type: Easytronic	<b>F8-6980</b>		
Engine Mounting	1.8	ch.→82138052, 85097612, 88081332, 8G125960; Code: KZ KD;	<b>F8-6980</b>		
Engine Mounting	1.8	Code: KZ KD;	<b>F8-6980</b>		
Engine Mounting	1.7 CDTi	Code: KZ KA;	<b>F8-6984</b>		
Anti-Friction Bearing	1.3 CDTi, 1.6, 1.7 CDTi, 1.8		<b>F8-7172</b>		
Top Strut Mounting	1.3 CDTi, 1.6, 1.7 CDTi, 1.8	Additionally required articles: F8-7625;	<b>F8-7327</b>		
Top Strut Mounting	1.3 CDTi, 1.6, 1.7 CDTi, 1.8		<b>F8-7328</b>		
Top Strut Mounting	1.3 CDTi, 1.6, 1.7 CDTi, 1.8		<b>F8-7328S</b>		

<b>F5-1041</b>	<b>F5-1045</b>	<b>F5-1049</b>	<b>F8-6733</b>	<b>F8-6734</b>	<b>F8-6975</b>	<b>F8-6980</b>
Ref.Nr.: 77364723	Ref.Nr.: 77362721	Ref.Nr.: 1204366	Ref.Nr.: 13107328	Ref.Nr.: 302275	Ref.Nr.: 24459803	Ref.Nr.: 13125637
<b>F8-6984</b>	<b>F8-7172</b>	<b>F8-7327</b>	<b>F8-7328</b>	<b>F8-7328S</b>	<b>F8-7625</b>	<b>F8-7699</b>
Ref.Nr.: 13159997	Ref.Nr.: 9191181	Ref.Nr.: 13186960	Ref.Nr.: 13270705	Ref.Nr.: 344625	Ref.Nr.: 24402155	Ref.Nr.: 13117280
<b>F8-7847</b>	<b>F8-7872</b>	<b>F8-7926</b>	<b>F8-7944</b>	<b>F8-7946</b>	<b>F8-8137</b>	<b>F8-8142</b>
Ref.Nr.: 90576351	Ref.Nr.: 614758	Ref.Nr.: 350161	Ref.Nr.: 402 952	Ref.Nr.: 352324	Ref.Nr.: 682502	Ref.Nr.: 90538582

Article Description



Article Nr.

Fitting Position



<b>ASTRA H Saloon (L69)</b>			<b>02/2007 →</b>		
Mounting Kit, shock absorber	1.3 CDTi, 1.6, 1.7 CDTi, 1.8	for article nr: A-3246GL & A-3246GR, F8-7327	<b>F8-7625</b>		
Rubber Buffer, suspension	1.3 CDTi, 1.6, 1.7 CDTi, 1.8		<b>F8-7662</b>		H=40
Protective Cap/Bellow, shock absorber	1.3 CDTi, 1.6, 1.7 CDTi, 1.8		<b>F8-7663</b>		H=205
Rubber Buffer, suspension	1.3 CDTi, 1.6, 1.7 CDTi		<b>F8-7699</b>		H=50
Rubber Buffer, suspension	1.8	ch.→4299999, 4599999, 4899999;	<b>F8-7699</b>		H=50
Rubber Buffer, suspension	1.8	ch.52000001, 55000001, 58000001→;	<b>F8-7699</b>		H=50
Rubber Buffer, suspension	1.3 CDTi, 1.6, 1.7 CDTi, 1.8		<b>F8-7847</b>		
Belt Pulley, crankshaft	1.7 CDTi	Number of Ribs: 5; Parameter: 6PK	<b>F8-7872</b>		Belt Pulley Ø [mm]=149; H1=22; H2=32
Stabiliser Mounting	1.3 CDTi, 1.6, 1.7 CDTi, 1.8	ch.→52999999, 55999999, 58999999	<b>F8-7926</b>		d=21
Mounting, axle beam	1.3 CDTi, 1.6, 1.7 CDTi		<b>F8-7944</b>		d=13
Mounting, axle beam	1.8		<b>F8-7944</b>		d=13
Control Arm-/Trailing Arm Bush	1.6, 1.8		<b>F8-7946</b>		
Engine Mounting	1.6, 1.7 CDTi, 1.8		<b>F8-8137</b>		
Engine Mounting	1.3 CDTi, 1.6, 1.8		<b>F8-8142</b>		

<b>ASTRA H TwinTop (L67)</b>			<b>09/2005 →</b>		
Dust Cover Kit, shock absorber	All Models		<b>AK-735252</b>		
Alternator Freewheel Clutch	2.0 Turbo		<b>F5-1100</b>		
Alternator Freewheel Clutch	1.9 CDTi		<b>F5-1102</b>		
Alternator Freewheel Clutch	1.9 CDTi		<b>F5-1123</b>		
Mounting, axle beam	All Models		<b>F8-6733</b>		d=14; L=35; D1=46; D2=38.4
Mounting, axle beam	All Models		<b>F8-6734</b>		H=35.2; d=14.2; D1=45.9; D2=35.2
Engine Mounting	1.9 CDTi		<b>F8-6836</b>		
Engine Mounting	1.6	Code: KZ JE	<b>F8-6975</b>		
Engine Mounting	1.8	Code: KZ JE;	<b>F8-6975</b>		
Engine Mounting	1.6, 1.6 Turbo, 1.8	Code: KZ KD	<b>F8-6980</b>		
Engine Mounting	1.9 CDTi	Code: KZ KA;	<b>F8-6984</b>		
Engine Mounting	1.9 CDTi	Code: KB;	<b>F8-6985</b>		
Anti-Friction Bearing	All Models		<b>F8-7172</b>		
Top Strut Mounting	All Models	Additionally required articles: F8-7625;	<b>F8-7327</b>		
Top Strut Mounting	All Models		<b>F8-7328</b>		

<b>AK-735252</b>	<b>F5-1100</b>	<b>F5-1102</b>	<b>F5-1123</b>	<b>F8-6733</b>	<b>F8-6734</b>	<b>F8-6836</b>
Ref.Nr.: 344416	Ref.Nr.: 1204393	Ref.Nr.: 1204151	Ref.Nr.: 9948513	Ref.Nr.: 13107328	Ref.Nr.: 302275	Ref.Nr.: 2442798
<b>F8-6975</b>	<b>F8-6980</b>	<b>F8-6984</b>	<b>F8-6985</b>	<b>F8-7172</b>	<b>F8-7327</b>	<b>F8-7328</b>
Ref.Nr.: 24459803	Ref.Nr.: 13125637	Ref.Nr.: 13159997	Ref.Nr.: 13159998	Ref.Nr.: 9191181	Ref.Nr.: 13186960	Ref.Nr.: 13270705
<b>F8-7328S</b>	<b>F8-7625</b>	<b>F8-7662</b>	<b>F8-7663</b>	<b>F8-7699</b>	<b>F8-7847</b>	<b>F8-7872</b>
Ref.Nr.: 344625	Ref.Nr.: 24402155	Ref.Nr.: 0344956	Ref.Nr.: 344435	Ref.Nr.: 13117280	Ref.Nr.: 90576351	Ref.Nr.: 614758



**Article Description****Article Nr.****Fitting Position**

<b>ASTRA H TwinTop (L67)</b>				<b>09/2005 →</b>	
Top Strut Mounting	All Models		<b>F8-7328S</b>		
Mounting Kit, shock absorber	All Models	for article nr: A-3246GL & A-3246GR, F8-7327	<b>F8-7625</b>		
Rubber Buffer, suspension	All Models		<b>F8-7662</b>		H=40
Protective Cap/Bellow, shock absorber	All Models		<b>F8-7663</b>		H=205
Rubber Buffer, suspension	All Models		<b>F8-7847</b>		
Mounting, axle beam	1.6, 1.6 Turbo, 1.8, 1.9 CDTi, 2.0 Turbo		<b>F8-7944</b>		d=13
Mounting, axle beam	1.8	Z 18 XER	<b>F8-7944</b>		d=13
Control Arm-/Trailing Arm Bush	1.6, 1.6 Turbo, 1.8, 1.9 CDTi, 2.0 Turbo		<b>F8-7946</b>		
Engine Mounting	All Models		<b>F8-8137</b>		
Engine Mounting	1.6, 1.8		<b>F8-8142</b>		
<b>ASTRA H Van (L70)</b>				<b>02/2004 → 11/2004</b>	
Alternator Freewheel Clutch	1.3 CDTi		<b>F5-1041</b>		
Alternator Freewheel Clutch	1.3 CDTi		<b>F5-1045</b>		
Alternator Freewheel Clutch	1.7 CDTi		<b>F5-1049</b>		
Alternator Freewheel Clutch	1.9 CDTi		<b>F5-1102</b>		
Alternator Freewheel Clutch	1.9 CDTi, 1.9 CDTi 16V		<b>F5-1123</b>		
Engine Mounting	1.7 CDTi	Code: KZ KA;  Z 17 DTJ;	<b>F8-6984</b>		
Engine Mounting	1.7 CDTi	Code: KZ KA;  Z 17 DTR;	<b>F8-6984</b>		
Engine Mounting	1.9 CDTi	Code: KZ KA	<b>F8-6984</b>		
Engine Mounting	1.9 CDTi, 1.9 CDTi 16V	Code: KB;	<b>F8-6985</b>		
Mounting Kit, shock absorber	1.3 CDTi, 1.7 CDTi, 1.9 CDTi, 1.9 CDTi 16V	for article nr: A-3246GL & A-3246GR, F8-7327	<b>F8-7625</b>		
Rubber Buffer, suspension	1.3 CDTi, 1.7 CDTi, 1.9 CDTi	ch.52000001, 55000001, 58000001, 8B000001→;	<b>F8-7662</b>		H=40
Protective Cap/Bellow, shock absorber	1.3 CDTi, 1.7 CDTi, 1.9 CDTi		<b>F8-7663</b>		H=205
Rubber Buffer, suspension	1.3 CDTi, 1.7 CDTi, 1.9 CDTi	ch.→4299999, 4599999, 4899999;	<b>F8-7699</b>		H=50
Rubber Buffer, suspension	1.3 CDTi, 1.7 CDTi, 1.9 CDTi	ch.52000001, 55000001, 58000001→;	<b>F8-7699</b>		H=50
Rubber Buffer, suspension	1.6	ch.→4299999, 4599999, 4899999	<b>F8-7699</b>		H=50
Rubber Buffer, suspension	1.6	ch.52000001, 55000001, 58000001, 8B000001→;	<b>F8-7699</b>		H=50
Rubber Buffer, suspension	1.3 CDTi, 1.6, 1.7 CDTi, 1.9 CDTi		<b>F8-7847</b>		
Mounting, axle beam	1.7 CDTi	Z 17 DTJ	<b>F8-7944</b>		d=13
Mounting, axle beam	1.7 CDTi	Z 17 DTR	<b>F8-7944</b>		d=13

<b>F5-1041</b>	<b>F5-1045</b>	<b>F5-1049</b>	<b>F5-1102</b>	<b>F5-1123</b>	<b>F8-6984</b>	<b>F8-6985</b>
Ref.Nr.: 77364723	Ref.Nr.: 77362721	Ref.Nr.: 1204366	Ref.Nr.: 1204151	Ref.Nr.: 9948513	Ref.Nr.: 13159997	Ref.Nr.: 13159998
<b>F8-7328S</b>	<b>F8-7625</b>	<b>F8-7662</b>	<b>F8-7663</b>	<b>F8-7699</b>	<b>F8-7847</b>	<b>F8-7944</b>
Ref.Nr.: 344625	Ref.Nr.: 24402155	Ref.Nr.: 0344956	Ref.Nr.: 344435	Ref.Nr.: 13117280	Ref.Nr.: 90576351	Ref.Nr.: 402 952
<b>F8-7946</b>	<b>F8-8137</b>	<b>F8-8142</b>				
Ref.Nr.: 352324	Ref.Nr.: 682502	Ref.Nr.: 90538582				

Article Description



Article Nr.

Fitting Position



ASTRA J			12/2009 →		
Top Strut Mounting	1.3 CDTI, 1.4, 1.4 LPG, 1.4 Turbo, 1.6, 1.6 Turbo, 1.7 CDTI, 2.0 CDTI		F8-7616		H=49; D=114
Rubber Buffer, suspension	1.3 CDTI, 1.4, 1.4 Turbo, 1.6, 1.6 Turbo, 1.7 CDTI, 2.0 CDTI		F8-7621		H=270
Rubber Buffer, suspension	1.7 CDTI	A17DTJ;	F8-7621		H=270
Belt Pulley, crankshaft	1.7 CDTI	Number of Ribs: 5; Parameter: 6PK	F8-7872		Belt Pulley Ø [mm]=149; H1=22; H2=32
ASTRA GTC J			10/2011 →		
Top Strut Mounting	1.4, 1.6, 1.7 CDTI, 1.8, 2.0, 2.0 CDTI		F8-7616		H=49; D=114
Protective Cap/Bellow, shock absorber	1.6		F8-7663		H=205
ASTRA J Saloon			06/2012 →		
Top Strut Mounting	1.3 CDTI, 1.4, 1.4 Turbo, 1.6, 1.6 Turbo, 1.7 CDTI		F8-7616		H=49; D=114
ASTRA J Sports Tourer			10/2010 →		
Top Strut Mounting	1.3 CDTI, 1.4, 1.4 LPG, 1.4 Turbo, 1.6, 1.6 Turbo, 1.7 CDTI, 2.0 CDTI		F8-7616		H=49; D=114
CALIBRA A (85_)			06/1990 → 07/1997		
Dust Cover Kit, shock absorber	All Models		AK-735003		
Mounting, alternator	2.0i, 2.0 i 16V, 2.0 i 16V 4x4, 2.0 i 4x4, 2.0 i Turbo 4x4	ch.L1000001→; ch.→L1299999	F7-2054		H=27; d=8; D1=18; D2=22
Anti-Friction Bearing	All Models		F8-3026		H=11; d1=16; d2=22; D=41
Control Arm-/Trailing Arm Bush	All Models		F8-4099		H=70; d=12; D1=46; D2=49
Stabiliser Mounting	All Models		F8-5332		d=22
Mounting, stabilizer coupling rod	All Models		F8-5333		d=8.5; D=30
Control Arm-/Trailing Arm Bush	2.0 i 16V, 2.0 i 16V 4x4	ch.R003109→	F8-5334		d=16; D=60; Thick. [mm]=58
Control Arm-/Trailing Arm Bush	2.0 i 16V, 2.0 i 16V 4x4, 2.0 i Turbo 4x4, 2.5 i V6	ch.R9003175→	F8-5334		d=16; D=60; Thick. [mm]=58
Control Arm-/Trailing Arm Bush	2.0 i, 2.0 i 4x4	ch.R9003128→	F8-5334		d=16; D=60; Thick. [mm]=58
Stabiliser Mounting	All Models		F8-5338		d=13; D=26
Engine Mounting	2.0 i, 2.0 i 16V		F8-5374		
Engine Mounting	2.5 i V6		F8-5374		
Engine Mounting	2.0 i, 2.0 i 16V, 2.0 i 16V 4x4, 2.0 i 4x4	ch.N1133945, N9020268→;	F8-5418		
Engine Mounting	2.0 i 16V, 2.0 i 16V 4x4, 2.0 i Turbo 4x4		F8-5436		
Engine Mounting	2.0 i, 2.0 i 16V, 2.0 i 16V 4x4, 2.0 i 4x4, 2.5 i V6		F8-5436		
Engine Mounting	2.0 i 16V, 2.0 i 16V 4x4, 2.0 i Turbo 4x4		F8-5438		
Engine Mounting	2.0 i, 2.0 i 4x4		F8-5438		

<b>AK-735003</b>	<b>F7-2054</b>	<b>F8-3026</b>	<b>F8-4099</b>	<b>F8-5332</b>	<b>F8-5333</b>	<b>F8-5334</b>
Ref.Nr.: <b>AK-735003</b>	Ref.Nr.: <b>1204879</b>	Ref.Nr.: <b>90425479</b>	Ref.Nr.: <b>0423313</b>	Ref.Nr.: <b>0350078</b>	Ref.Nr.: <b>2875013</b>	Ref.Nr.: <b>352356</b>
<b>F8-5338</b>	<b>F8-5374</b>	<b>F8-5418</b>	<b>F8-5436</b>	<b>F8-5438</b>	<b>F8-5445</b>	<b>F8-7616</b>
Ref.Nr.: <b>0444325</b>	Ref.Nr.: <b>0684647</b>	Ref.Nr.: <b>684646</b>	Ref.Nr.: <b>0684641</b>	Ref.Nr.: <b>684291</b>	Ref.Nr.: <b>0682504</b>	Ref.Nr.: <b>0344573</b>
<b>F8-7621</b>	<b>F8-7663</b>	<b>F8-7872</b>				
Ref.Nr.: <b>13251764</b>	Ref.Nr.: <b>344435</b>	Ref.Nr.: <b>614758</b>				

**Article Description****Article Nr.****Fitting Position****CALIBRA A (85\_)****06/1990 → 07/1997**

Engine Mounting	2.0 i 16V		<b>F8-5445</b>				
Engine Mounting	2.0 i 16V, 2.0 i 16V 4x4		<b>F8-5467</b>				
Engine Mounting	2.0 i, 2.0 i 16V, 2.0 i 16V 4x4, 2.0 i 4x4	ch.→N9020267;	<b>F8-5468</b>				
Top Strut Mounting	All Models		<b>F8-5501</b>				H=46; d=16; D=109
Top Strut Mounting	All Models		<b>F8-5501S</b>				
Rubber Buffer, suspension	2.0 i Turbo 4x4		<b>F8-5692</b>				H=67
Stabiliser Mounting	All Models		<b>F8-5724</b>				d=14
Control Arm-/Trailing Arm Bush	2.0 i 16V, 2.0 i 16V 4x4, 2.0 i Turbo 4x4, 2.5 i V6		<b>F8-5968</b>				d=12
Control Arm-/Trailing Arm Bush	2.0 i 16V, 2.0 i 16V 4x4, 2.0 i Turbo 4x4, 2.5 i V6	ch.→R9003174	<b>F8-5969</b>				H=58; d=16; D=60
Stabiliser Mounting	All Models		<b>F8-5970</b>				H=29; D1=32; D2=29
Sleeve, control arm mounting	All Models		<b>F8-6656</b>				
Top Strut Mounting	All Models	Bearing Type: Soft Version;	<b>F8-7973</b>				
Control Arm-/Trailing Arm Bush	2.0 i 16V, 2.0 i 16V 4x4		<b>G9-593</b>				d=12; D1=39; D2=44
Control Arm-/Trailing Arm Bush	2.0 i, 2.0 i 4x4, 2.0 i Turbo 4x4, 2.5 i V6	ch.→R9003126	<b>G9-593</b>				d=12; D1=39; D2=44
Control Arm-/Trailing Arm Bush	2.0 i 16V, 2.0 i 16V 4x4		<b>G9-594</b>				H1=27; H2=58; d=16; D1=60; D2=66
Control Arm-/Trailing Arm Bush	2.0 i, 2.0 i 4x4, 2.0 i Turbo 4x4, 2.5 i V6	ch.R9003127→	<b>G9-594</b>				H1=27; H2=58; d=16; D1=60; D2=66
C.V. Boot	2.0 i, 2.0 i 16V, 2.0 i 16V 4x4, 2.0 i 4x4, 2.0 i Turbo 4x4	ch.N1000001, N2000001, N5000001→; ch.→N2733477, N5273484, P8202125	<b>M-822900</b>				
Bellow Set, drive shaft	2.0 i, 2.0 i 16V, 2.0 i 16V 4x4, 2.0 i 4x4, 2.0 i Turbo 4x4	ch.→R1..., R9...	<b>MK-822920</b>				
Bellow Set, drive shaft	2.5 i V6		<b>MK-822920</b>				

**COMBO (71\_)****07/1994 → 10/2001**

Dust Cover Kit, shock absorber	1.2, 1.4, 1.7 D		<b>AK-735003</b>				
Anti-Friction Bearing	1.4		<b>F8-3025</b>				d=22
Anti-Friction Bearing	1.2, 1.4, 1.7 D		<b>F8-3027</b>				H=27; d=12; D1=95; D2=130
Stabiliser Mounting	1.2, 1.4, 1.7 D		<b>F8-5228</b>				d=21.5
Top Strut Mounting	1.4		<b>F8-5304S</b>				
Stabiliser Mounting	1.4		<b>F8-5332</b>				d=22
Mounting, alternator	1.2	ch.→R3999999, R4999999;	<b>F8-5366</b>				
Mounting, alternator	1.4	ch.→R3999999, R4999999; ,	<b>F8-5366</b>				
Engine Mounting	1.4		<b>F8-5371</b>				
Top Strut Mounting	All Models		<b>F8-5450</b>				
Rubber Buffer, suspension	1.2, 1.4, 1.4 16V		<b>F8-5707</b>				H=54

<b>AK-735003</b>	<b>F8-3025</b>	<b>F8-3027</b>	<b>F8-5228</b>	<b>F8-5304S</b>	<b>F8-5332</b>	<b>F8-5366</b>
Ref.Nr.:	Ref.Nr.: 90374844	Ref.Nr.: 90170695	Ref.Nr.: 350127	Ref.Nr.: 344531	Ref.Nr.: 0350078	Ref.Nr.: 1204885
<b>F8-5371</b>	<b>F8-5445</b>	<b>F8-5450</b>	<b>F8-5467</b>	<b>F8-5468</b>	<b>F8-5501</b>	<b>F8-5501S</b>
Ref.Nr.: 0684669	Ref.Nr.: 0682504	Ref.Nr.: 0344519	Ref.Nr.: 0684285	Ref.Nr.: 0684283	Ref.Nr.: 90268464	Ref.Nr.: 90289421
<b>F8-5692</b>	<b>F8-5707</b>	<b>F8-5724</b>	<b>F8-5968</b>	<b>F8-5969</b>	<b>F8-5970</b>	<b>F8-6037</b>
Ref.Nr.: 0344411	Ref.Nr.: 0344403	Ref.Nr.: 0444153	Ref.Nr.: 352351	Ref.Nr.: 352352	Ref.Nr.: 0444347	Ref.Nr.: 0353281

Article Description



Article Nr.

Fitting Position



<b>COMBO (71_)</b>				07/1994 → 10/2001	
Tie Bar Bush	All Models	ch.3037204 →	<b>F8-6037</b>		
Tie Bar Bush	All Models	ch.3037204 →	<b>F8-6038</b>		
Rubber Buffer, suspension	All Models		<b>F8-6517</b>		
Engine Mounting	1.2		<b>F8-8166</b>		
Control Arm-/Trailing Arm Bush	1.2, 1.4, 1.7 D		<b>G9-590</b>		H=52; d1=10; d2=14; D1=38; D2=45
<b>COMBO Box Body / Estate</b>				10/2001 →	
Alternator Freewheel Clutch	1.3 CDTI 16V		<b>F5-1041</b>		
Alternator Freewheel Clutch	1.3 CDTI 16V		<b>F5-1045</b>		
Alternator Freewheel Clutch	1.7 CDTI 16V		<b>F5-1049</b>		
Control Arm-/Trailing Arm Bush	All Models		<b>F8-5262</b>		
Suspension Kit	All Models	with fastening material;	<b>F8-5263</b>		
Top Strut Mounting	1.6, 1.7 CDTI 16V, 1.7 DI 16V, 1.7 DTI 16V		<b>F8-5463</b>		
Rubber Buffer, suspension	All Models		<b>F8-6517</b>		
Engine Mounting	1.3 CDTI 16V, 1.6 CNG 16V, 1.7 DI 16V, 1.7 DTI 16V		<b>F8-6753</b>		
Engine Mounting	1.4 16V, 1.6		<b>F8-6753</b>		
Rubber Buffer, suspension	1.3 CDTI 16V, 1.4 16V, 1.6, 1.6 CNG 16V, 1.7 CDTI 16V, 1.7 DI 16V, 1.7 DTI 16V		<b>F8-7698</b>		H=63
Engine Mounting	1.4 16V		<b>F8-7793</b>		
Engine Mounting	1.4 16V		<b>F8-7794</b>		
Stabiliser Mounting	All Models	ch.43000001, 74000001 →	<b>F8-7926</b>		d=21
Repair Kit, suspension strut	All Models		<b>F8-8085</b>		
Engine Mounting	1.4 16V, 1.6, 1.7 DI 16V, 1.7 DTI 16V		<b>F8-8158</b>		
Engine Mounting	1.4 16V, 1.6, 1.7 DI 16V, 1.7 DTI 16V		<b>F8-8161</b>		
Repair Kit, suspension strut	All Models	Bearing Type: Hard Version;	<b>F8-8214</b>		
<b>COMBO Tour</b>				10/2001 →	
Alternator Freewheel Clutch	1.3 CDTI 16V		<b>F5-1041</b>		
Alternator Freewheel Clutch	1.3 CDTI 16V		<b>F5-1045</b>		
Alternator Freewheel Clutch	1.7 CDTI 16V		<b>F5-1049</b>		
Control Arm-/Trailing Arm Bush	All Models		<b>F8-5262</b>		
Suspension Kit	1.3 CDTI 16V, 1.6, 1.6 CNG, 1.7 CDTI 16V, 1.7 DI 16V, 1.7 DTI 16V	with fastening material;	<b>F8-5263</b>		
Rubber Buffer, suspension	All Models		<b>F8-6517</b>		
Engine Mounting	1.3 CDTI 16V, 1.6 CNG, 1.7 DI 16V, 1.7 DTI 16V		<b>F8-6753</b>		
Engine Mounting	1.6		<b>F8-6753</b>		

<b>F5-1041</b>	<b>F5-1045</b>	<b>F5-1049</b>	<b>F8-5262</b>	<b>F8-5263</b>	<b>F8-5463</b>	<b>F8-6037</b>
Ref.Nr.: 77364723	Ref.Nr.: 77362721	Ref.Nr.: 1204366	Ref.Nr.: 13138151	Ref.Nr.: 352309	Ref.Nr.: 0344525	Ref.Nr.: 0353281
<b>F8-6038</b>	<b>F8-6517</b>	<b>F8-6753</b>	<b>F8-7698</b>	<b>F8-7793</b>	<b>F8-7794</b>	<b>F8-7926</b>
Ref.Nr.: 0353280	Ref.Nr.: 90468618	Ref.Nr.: 0684238	Ref.Nr.: 24403535	Ref.Nr.: 13125209	Ref.Nr.: 13125208	Ref.Nr.: 350161
<b>F8-8085</b>	<b>F8-8158</b>	<b>F8-8161</b>	<b>F8-8166</b>	<b>F8-8214</b>	<b>G9-590</b>	
Ref.Nr.: 344523	Ref.Nr.: 684713	Ref.Nr.: 846000	Ref.Nr.: 682600	Ref.Nr.: 312510	Ref.Nr.: 0352301	

**Article Description****Article Nr.****Fitting Position**

<b>COMBO Tour</b>				<b>10/2001 →</b>	
Rubber Buffer, suspension	1.3 CDTI 16V, 1.4, 1.6, 1.6 CNG, 1.7 CDTI 16V, 1.7 DI 16V, 1.7 DTI 16V		<b>F8-7698</b>		H=63
Engine Mounting	1.4		<b>F8-7793</b>		
Engine Mounting	1.4		<b>F8-7794</b>		
Stabiliser Mounting	All Models	ch.43000001, 74000001→	<b>F8-7926</b>		d=21
Repair Kit, suspension strut	All Models		<b>F8-8085</b>		
Engine Mounting	1.4, 1.6, 1.7 DI 16V, 1.7 DTI 16V		<b>F8-8158</b>		
Engine Mounting	1.4, 1.6, 1.7 DI 16V, 1.7 DTI 16V		<b>F8-8161</b>		
Repair Kit, suspension strut	1.3 CDTI 16V, 1.4, 1.6, 1.6 CNG, 1.7 CDTI 16V, 1.7 DI 16V, 1.7 DTI 16V	Bearing Type: Hard Version;	<b>F8-8214</b>		
<b>COMBO Box Body / Estate (X12)</b>				<b>02/2012 →</b>	
Alternator Freewheel Clutch	1.3 CDTI		<b>F5-1041</b>		
Alternator Freewheel Clutch	1.6 CDTI, 2.0 CDTI		<b>F5-1072</b>		
Alternator Freewheel Clutch	1.6 CDTI, 2.0 CDTI		<b>F5-1098</b>		
Protective Cap/Bellow, shock absorber	1.3 CDTI, 1.4, 1.4 CNG, 1.6 CDTI, 2.0 CDTI		<b>F8-7663</b>		H=205
<b>COMBO Tour (X12)</b>				<b>02/2012 →</b>	
Alternator Freewheel Clutch	1.3 CDTI		<b>F5-1041</b>		
Alternator Freewheel Clutch	1.6 CDTI, 2.0 CDTI		<b>F5-1072</b>		
Alternator Freewheel Clutch	1.6 CDTI, 2.0 CDTI		<b>F5-1098</b>		
Protective Cap/Bellow, shock absorber	1.3 CDTI, 1.4, 1.4 CNG, 1.6 CDTI, 2.0 CDTI		<b>F8-7663</b>		H=205
<b>COMMODORE C (14_, 19_)</b>				<b>08/1978 → 12/1982</b>	
Dust Cover Kit, shock absorber	All Models		<b>AK-735005</b>		
Mounting, alternator	All Models		<b>F7-2055</b>		H=9; d=8; D=26
Mounting, stabilizer coupling rod	All Models		<b>F8-5333</b>		d=8.5; D=30
Mounting, alternator	2.5 E	Engine3287→	<b>F8-5366</b>		
Mounting, alternator	2.5 S	Engine248829→	<b>F8-5366</b>		
<b>COMMODORE C Estate (61)</b>				<b>12/1980 → 12/1982</b>	
Dust Cover Kit, shock absorber	All Models		<b>AK-735005</b>		
Mounting, alternator	All Models		<b>F7-2055</b>		H=9; d=8; D=26
Mounting, stabilizer coupling rod	All Models		<b>F8-5333</b>		d=8.5; D=30
Mounting, alternator	2.5 E	Engine3287→	<b>F8-5366</b>		
Mounting, alternator	2.5 S	Engine248829→	<b>F8-5366</b>		

<b>AK-735003</b>	<b>AK-735005</b>	<b>F5-1041</b>	<b>F5-1072</b>	<b>F5-1098</b>	<b>F7-2055</b>	<b>F8-5333</b>
Ref.Nr.:	Ref.Nr.:	Ref.Nr.: 77364723	Ref.Nr.: 30667067	Ref.Nr.: 77364725	Ref.Nr.: 1204892	Ref.Nr.: 2875013
<b>F8-5366</b>	<b>F8-7663</b>	<b>F8-7698</b>	<b>F8-7793</b>	<b>F8-7794</b>	<b>F8-7926</b>	<b>F8-8085</b>
Ref.Nr.: 1204885	Ref.Nr.: 344435	Ref.Nr.: 24403535	Ref.Nr.: 13125209	Ref.Nr.: 13125208	Ref.Nr.: 350161	Ref.Nr.: 344523
<b>F8-8158</b>	<b>F8-8161</b>	<b>F8-8214</b>				
Ref.Nr.: 684713	Ref.Nr.: 846000	Ref.Nr.: 312510				

Article Description

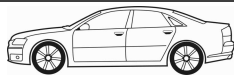

Article Nr.

Fitting Position



<b>CORSA A Hatchback (93, 94, 98, 99)</b>		<b>09/1982 → 03/1993</b>	
Dust Cover Kit, shock absorber	1.0, 1.2, 1.2 i, 1.2 N, 1.2 S, 1.3, 1.3 i, 1.3 S, 1.4 i, 1.4 S, 1.4 Si, 1.5 D, 1.5 TD, 1.6 GSI, 1.6 GSI CAT	AK-735003	
Mounting, alternator	1.0, 1.2, 1.2 N, 1.2 S, 1.3, 1.3 i, 1.3 S, 1.6 GSI, 1.6 GSI CAT	F7-2055	H=9; d=8; D=26
Anti-Friction Bearing	1.0, 1.2, 1.2 i, 1.2 N, 1.2 S, 1.3, 1.3 i, 1.3 S, 1.4 i, 1.4 S, 1.4 Si, 1.5 D, 1.5 TD, 1.6 GSI, 1.6 GSI CAT	F8-3027	H=27; d=12; D1=95; D2=130
Tie Bar Bush	1.0, 1.2, 1.2 i, 1.2 N, 1.2 S, 1.3, 1.3 i, 1.3 S, 1.4 i, 1.4 S, 1.4 Si, 1.5 D, 1.5 TD, 1.6 GSI, 1.6 GSI CAT	F8-5101	H=36; d=14; D=45
Control Arm-/Trailing Arm Bush	1.0, 1.2, 1.2 i, 1.2 N, 1.2 S, 1.3, 1.3 i, 1.3 S, 1.4 i, 1.4 S, 1.4 Si, 1.5 D, 1.5 TD, 1.6 GSI, 1.6 GSI CAT	F8-5112	H=52; d=10; D=33
Stabiliser Mounting	1.2, 1.2 i, 1.2 N, 1.2 S	ch.Y2000001, Y5000001→	F8-5230  d=18
Mounting, alternator	1.0, 1.2, 1.4 i, 1.4 S, 1.4 Si, 1.6 GSI, 1.6 GSI CAT	F8-5366	
Mounting, alternator	1.2 N, 1.2 S, 1.3 GL, 1.3 S	Engine1073534→	F8-5366
Top Strut Mounting	All Models		F8-5434
Engine Mounting	1.5 D, 1.5 TD		F8-5440
Control Arm-/Trailing Arm Bush	1.0, 1.2, 1.2 i, 1.2 N, 1.2 S, 1.3, 1.3 i, 1.3 S, 1.4 i, 1.4 S, 1.4 Si, 1.5 D, 1.5 TD, 1.6 GSI, 1.6 GSI CAT		F8-5552  d=10; L=65; D=42
Rubber Buffer, suspension	1.0, 1.2, 1.2 i, 1.2 N, 1.2 S, 1.3, 1.3 i, 1.3 S, 1.4 i, 1.4 S, 1.4 Si, 1.5 D, 1.5 TD, 1.6 GSI, 1.6 GSI CAT		F8-5611
Rubber Buffer, suspension	All Models		F8-5707  H=54
Engine Mounting	1.0, 1.2, 1.2 i, 1.2 N, 1.2 S, 1.3, 1.3 i, 1.3 S, 1.4 i, 1.4 S, 1.4 Si, 1.6 GSI, 1.6 GSI CAT		F8-6883
Engine Mounting	1.4 i, 1.4 S, 1.4 Si		F8-8145
<b>CORSA A Box</b>		<b>02/1986 → 07/1990</b>	
Dust Cover Kit, shock absorber	1.0, 1.2, 1.3	AK-735003	
Anti-Friction Bearing	1.0, 1.2, 1.3, 1.5 D	F8-3027	H=27; d=12; D1=95; D2=130
Control Arm-/Trailing Arm Bush	1.0, 1.2, 1.3, 1.5 D		F8-5112  H=52; d=10; D=33
Top Strut Mounting	1.0, 1.2, 1.3, 1.5 D		F8-5434
Engine Mounting	1.5 D		F8-5440
Rubber Buffer, suspension	All Models		F8-5611
Rubber Buffer, suspension	1.0, 1.2, 1.5 D		F8-5707  H=54
Tie Bar Bush	1.5 D		F8-6037
Engine Mounting	1.0, 1.2, 1.3		F8-6883
<b>CORSA A TR (91, 92, 96, 97)</b>		<b>09/1982 → 03/1993</b>	
Dust Cover Kit, shock absorber	1.0, 1.2 i, 1.2 N, 1.2 S, 1.3, 1.3 S, 1.4 i, 1.4 S, 1.5 D, 1.5 TD	AK-735003	
Mounting, alternator	1.0, 1.2 N, 1.2 S, 1.3, 1.3 S	F7-2055	H=9; d=8; D=26
Anti-Friction Bearing	1.0, 1.2 N, 1.2 S, 1.3, 1.3 S, 1.5 D	F8-3027	H=27; d=12; D1=95; D2=130

<b>AK-735003</b>	<b>F7-2055</b>	<b>F8-3027</b>	<b>F8-5101</b>	<b>F8-5112</b>	<b>F8-5230</b>	<b>F8-5366</b>
Ref.Nr.:	Ref.Nr.: 1204892	Ref.Nr.: 90170695	Ref.Nr.: 353560	Ref.Nr.: 0352327	Ref.Nr.: 0350138	Ref.Nr.: 1204885
<b>F8-5434</b>	<b>F8-5440</b>	<b>F8-5552</b>	<b>F8-5611</b>	<b>F8-5707</b>	<b>F8-6037</b>	<b>F8-6883</b>
Ref.Nr.: 344507	Ref.Nr.: 684281	Ref.Nr.: 90217845	Ref.Nr.: 0436940	Ref.Nr.: 0344403	Ref.Nr.: 0353281	Ref.Nr.: 0684262
<b>F8-8145</b>						
Ref.Nr.: 90189509						

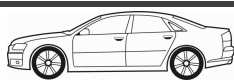
**Article Description****Article Nr.****Fitting Position**

<b>CORSA A TR (91_, 92_, 96_, 97_) 09/1982 → 03/1993</b>		
Tie Bar Bush	1.0, 1.2 N, 1.2 S, 1.3, 1.3 S	F8-5101
Control Arm-/Trailing Arm Bush	1.0, 1.2 i, 1.2 N, 1.2 S, 1.3, 1.3 S, 1.4 i, 1.4 S, 1.5 D, 1.5 TD	F8-5112
Stabiliser Mounting	1.2 N, 1.2 S ch.Y2000001, Y5000001→	F8-5230
Mounting, alternator	1.0, 1.2 N	F8-5366
Mounting, alternator	1.2 S, 1.3 GL, 1.3 S Engine1073534→	F8-5366
Top Strut Mounting	All Models	F8-5434
Engine Mounting	1.5 D, 1.5 TD	F8-5440
Control Arm-/Trailing Arm Bush	1.0, 1.2 i, 1.2 N, 1.2 S, 1.3, 1.3 S, 1.4 i, 1.4 S, 1.5 D, 1.5 TD	F8-5552
Rubber Buffer, suspension	1.0, 1.2 i, 1.2 N, 1.2 S, 1.3, 1.3 S, 1.4 i, 1.4 S, 1.5 D, 1.5 TD	F8-5611
Rubber Buffer, suspension	All Models	F8-5707
Engine Mounting	1.0, 1.2 i, 1.2 N, 1.2 S, 1.3, 1.3 S, 1.4 i, 1.4 S	F8-6883
<b>CORSA B (73_, 78_, 79_) 03/1993 → 09/2000</b>		
Dust Cover Kit, shock absorber	1.0 i 12V, 1.2 i, 1.2 i 16V, 1.4 i, 1.4 i 16V, 1.4 Si, 1.5 D, 1.5 TD, 1.6 GSI 16V, 1.6 i 16V, 1.7 D	AK-735003
Anti-Friction Bearing	1.0 i 12V, 1.2 i, 1.2 i 16V, 1.4 i, 1.4 i 16V, 1.4 Si, 1.5 D, 1.5 TD, 1.6 GSI 16V, 1.6 i 16V, 1.7 D	F8-3027
Control Arm-/Trailing Arm Bush	1.6 i 16V	F8-4090
Tie Bar Bush	1.0 i 12V, 1.2 i, 1.2 i 16V, 1.4, 1.4 i, 1.4 i 16V, 1.4 Si, 1.5 D, 1.5 TD, 1.6 GSI 16V, 1.6 i 16V, 1.7 D ch.→V3023597, V4166925, V6066277	F8-5128
Stabiliser Mounting	1.0 i 12V, 1.2 i, 1.2 i 16V, 1.4 i, 1.4 i 16V, 1.4 Si, 1.5 D, 1.5 TD, 1.6 GSI 16V, 1.6 i 16V, 1.7 D	F8-5228
Stabiliser Mounting	1.2 i, 1.2 i 16V ch.Y2000001, Y5000001→	F8-5230
Mounting, alternator	1.2 i	F8-5366
Mounting, alternator	1.4 ch.→R3999999, R4999999, R6999999;	F8-5366
Mounting, alternator	1.4 i, 1.4 Si	F8-5366
Engine Mounting	1.2 i ch.→S4276216;	F8-5371
Engine Mounting	1.4 i 16V	F8-5371
Engine Mounting	1.4 i, 1.4 Si	F8-5371
Engine Mounting	1.0 i 12V, 1.2 i 16V, 1.4 i 16V, 1.6 GSI 16V, 1.6 i 16V	F8-5373
Engine Mounting	1.2 i ch.S4276217→;	F8-5373
Engine Mounting	1.4 i, 1.4 Si	F8-5373
Engine Mounting	1.2 i ch.→S4276216;	F8-5437
Engine Mounting	1.4 i, 1.4 Si	F8-5437
Engine Mounting	1.5 D, 1.5 TD, 1.7 D	F8-5441



Article Description



Article Nr.

Fitting Position



<b>CORSA B (73_, 78_, 79_)</b>		<b>03/1993 → 09/2000</b>	
Engine Mounting	1.5 D, 1.5 TD, 1.7 D		<b>F8-5442</b>
Top Strut Mounting	1.0 i 12V, 1.2 i, 1.2 i 16V, 1.4, 1.4 i, 1.4 i 16V, 1.4 Si, 1.5 D, 1.5 TD, 1.6 GSI 16V, 1.6 i 16V, 1.7 D		<b>F8-5450</b>
Control Arm-/Trailing Arm Bush	1.0 i 12V, 1.2 i, 1.2 i 16V, 1.4 i, 1.4 i 16V, 1.4 Si, 1.5 D, 1.5 TD, 1.6 GSI 16V, 1.6 i 16V, 1.7 D		<b>F8-5552</b>
Rubber Buffer, suspension	1.0 i 12V, 1.2 i, 1.2 i 16V, 1.4 i, 1.4 i 16V, 1.4 Si, 1.5 D, 1.5 TD, 1.6 GSI 16V, 1.6 i 16V, 1.7 D		<b>F8-5707</b>
Tie Bar Bush	1.0 i 12V, 1.2 i, 1.2 i 16V, 1.4, 1.4 i, 1.4 i 16V, 1.4 Si, 1.5 D, 1.5 TD, 1.6 GSI 16V, 1.6 i 16V, 1.7 D	ch.→3023597, 4166925, 6066279	<b>F8-6037</b>
Tie Bar Bush	1.0 i 12V, 1.2 i, 1.2 i 16V, 1.4, 1.4 i, 1.4 i 16V, 1.4 Si, 1.5 D, 1.5 TD, 1.6 GSI 16V, 1.6 i 16V, 1.7 D	ch.→3023597	<b>F8-6038</b>
Top Strut Mounting	1.0 i 12V, 1.2 i, 1.2 i 16V, 1.4 i, 1.4 i 16V, 1.4 Si, 1.5 D, 1.5 TD, 1.6 GSI 16V, 1.6 i 16V, 1.7 D		<b>F8-6319</b>
Engine Mounting	1.0 i 12V, 1.2 i, 1.2 i 16V, 1.4, 1.4 i, 1.4 i 16V, 1.5 D, 1.5 TD, 1.6 GSI 16V, 1.6 i 16V, 1.7 D		<b>F8-8166</b>
Control Arm-/Trailing Arm Bush	1.0 i 12V, 1.2 i, 1.2 i 16V, 1.4 i, 1.4 i 16V, 1.4 Si, 1.5 D, 1.5 TD, 1.6 GSI 16V, 1.6 i 16V, 1.7 D		<b>G9-590</b>
<b>CORSA B Box (73_)</b>		<b>08/1999 → 09/2000</b>	
Dust Cover Kit, shock absorber	All Models		<b>AK-735003</b>
Anti-Friction Bearing	All Models		<b>F8-3027</b>
Engine Mounting	1.4 i		<b>F8-5371</b>
Engine Mounting	1.4 i		<b>F8-5373</b>
Engine Mounting	1.7 D		<b>F8-5441</b>
Engine Mounting	1.7 D		<b>F8-5442</b>
Top Strut Mounting	All Models		<b>F8-5450</b>
Control Arm-/Trailing Arm Bush	1.4 i		<b>F8-5552</b>
Tie Bar Bush	All Models	ch.→3023597, 4166925, 6066279	<b>F8-6037</b>
Tie Bar Bush	All Models	ch.→3023597, 4166925, 6066279	<b>F8-6038</b>
Top Strut Mounting	All Models		<b>F8-6319</b>
Engine Mounting	1.4 i		<b>F8-8166</b>
Control Arm-/Trailing Arm Bush	All Models		<b>G9-590</b>
<b>CORSA C (F08, F68)</b>		<b>09/2000 → 12/2009</b>	
Dust Cover Kit, shock absorber	1.8		<b>AK-735249</b>
Alternator Freewheel Clutch	1.0, 1.2, 1.3 CDTI		<b>F5-1041</b>
Alternator Freewheel Clutch	1.0, 1.2, 1.3 CDTI		<b>F5-1045</b>
Alternator Freewheel Clutch	1.7 CDTI		<b>F5-1049</b>
Alternator Freewheel Clutch	1.4, 1.8		<b>F5-1050</b>

<b>AK-735003</b>	<b>AK-735249</b>	<b>F5-1041</b>	<b>F5-1045</b>	<b>F5-1049</b>	<b>F5-1050</b>	<b>F8-3027</b>
Ref.Nr.: 344427	Ref.Nr.: 344427	Ref.Nr.: 77364723	Ref.Nr.: 77362721	Ref.Nr.: 1204366	Ref.Nr.: 1204412	Ref.Nr.: 90170695
<b>F8-5262</b>	<b>F8-5371</b>	<b>F8-5373</b>	<b>F8-5441</b>	<b>F8-5442</b>	<b>F8-5450</b>	<b>F8-5552</b>
Ref.Nr.: 13138151	Ref.Nr.: 0684669	Ref.Nr.: 0684666	Ref.Nr.: 0684160	Ref.Nr.: 0684126	Ref.Nr.: 0344519	Ref.Nr.: 90217845
<b>F8-5707</b>	<b>F8-6037</b>	<b>F8-6038</b>	<b>F8-6319</b>	<b>F8-8166</b>	<b>G9-590</b>	
Ref.Nr.: 0344403	Ref.Nr.: 0353281	Ref.Nr.: 0353280	Ref.Nr.: 0312503	Ref.Nr.: 682600	Ref.Nr.: 0352301	



**Article Description****Article Nr.****Fitting Position**

<b>CORSA C (F08, F68)</b>			<b>09/2000 → 12/2009</b>	
Control Arm-/Trailing Arm Bush	1.0, 1.2, 1.2 Twinport, 1.3 CDTI, 1.4, 1.4 Twinport, 1.7 CDTI, 1.7 DI, 1.7 DTI, 1.8		<b>F8-5262</b>	
Suspension Kit	1.0, 1.2	ch.→14999999, 16999999; with fastening material;	<b>F8-5263</b>	
Suspension Kit	1.0, 1.2 Twinport, 1.4 Twinport, 1.7 CDTI	with fastening material;	<b>F8-5263</b>	
Suspension Kit	1.4	ch.→13999999, 14999999, 16999999; with fastening material	<b>F8-5263</b>	
Top Strut Mounting	1.0, 1.2, 1.2 Twinport, 1.3 CDTI, 1.4, 1.4 Twinport, 1.7 CDTI, 1.7 DI, 1.7 DTI, 1.8	Bearing Type: Soft Version;	<b>F8-5448</b>	
Top Strut Mounting	1.0, 1.2, 1.2 Twinport, 1.3 CDTI, 1.4, 1.4 Twinport, 1.7 CDTI, 1.7 DI, 1.7 DTI, 1.8		<b>F8-5463</b>	
Engine Mounting	1.0, 1.2, 1.2 Twinport	Code: KZ FE	<b>F8-6203</b>	
Rubber Buffer, suspension	1.0, 1.2, 1.2 Twinport, 1.3 CDTI, 1.4, 1.4 Twinport, 1.7 CDTI, 1.7 DI, 1.7 DTI, 1.8		<b>F8-6517</b>	
Engine Mounting	1.3 CDTI, 1.7 DI, 1.7 DTI, 1.8		<b>F8-6753</b>	
Engine Mounting	1.4, 1.4 Twinport		<b>F8-6753</b>	
Belt Pulley, crankshaft	1.7 DI	09/2003 →; Number of Ribs: 6	<b>F8-7089</b>	
Belt Pulley, crankshaft	1.7 DTI	Number of Ribs: 6	<b>F8-7089</b>	
Rubber Buffer, suspension	1.0, 1.2, 1.3 CDTI, 1.4, 1.6 CNG, 1.7 CDTI, 1.7 DI, 1.7 DTI, 1.8		<b>F8-7698</b>	
Engine Mounting	1.0, 1.2, 1.2 Twinport, 1.4 Twinport		<b>F8-7793</b>	
Engine Mounting	1.0		<b>F8-7794</b>	
Engine Mounting	1.0, 1.2, 1.2 Twinport, 1.4 Twinport		<b>F8-7794</b>	
Stabiliser Mounting	1.0, 1.2, 1.2 Twinport		<b>F8-7929</b>	
Repair Kit, suspension strut	1.0, 1.2, 1.2 Twinport, 1.3 CDTI, 1.4, 1.4 Twinport, 1.7 CDTI, 1.7 DI, 1.7 DTI, 1.8		<b>F8-8085</b>	
Engine Mounting	1.0, 1.2, 1.2 Twinport, 1.4, 1.4 Twinport, 1.7 DI, 1.7 DTI, 1.8		<b>F8-8158</b>	
Engine Mounting	1.0, 1.2, 1.2 Twinport, 1.4, 1.4 Twinport, 1.7 DI, 1.7 DTI, 1.8		<b>F8-8161</b>	
<b>CORSA C Box (F08, W5L)</b>			<b>09/2000 →</b>	
Alternator Freewheel Clutch	1.3 CDTI 16V		<b>F5-1041</b>	
Alternator Freewheel Clutch	1.3 CDTI 16V		<b>F5-1045</b>	
Alternator Freewheel Clutch	1.7 CDTI		<b>F5-1049</b>	
Control Arm-/Trailing Arm Bush	All Models		<b>F8-5262</b>	
Suspension Kit	1.2 16V	ch.→14999999, 16999999; with fastening material;	<b>F8-5263</b>	

<b>F5-1041</b>	<b>F5-1045</b>	<b>F5-1049</b>	<b>F8-5262</b>	<b>F8-5263</b>	<b>F8-5448</b>	<b>F8-5463</b>
Ref.Nr.: 77364723	Ref.Nr.: 77362721	Ref.Nr.: 1204366	Ref.Nr.: 13138151	Ref.Nr.: 352309	Ref.Nr.: 0344523	Ref.Nr.: 0344525
<b>F8-6203</b>	<b>F8-6517</b>	<b>F8-6753</b>	<b>F8-7089</b>	<b>F8-7698</b>	<b>F8-7793</b>	<b>F8-7794</b>
Ref.Nr.: 24416554	Ref.Nr.: 90468618	Ref.Nr.: 0684238	Ref.Nr.: 5614444	Ref.Nr.: 24403535	Ref.Nr.: 13125209	Ref.Nr.: 13125208
<b>F8-7929</b>	<b>F8-8085</b>	<b>F8-8158</b>	<b>F8-8161</b>			
Ref.Nr.: 350104	Ref.Nr.: 344523	Ref.Nr.: 684713	Ref.Nr.: 846000			

Article Description



Article Nr.

Fitting Position



<b>CORSA C Box (F08, W5L)</b>			<b>09/2000 →</b>	
Suspension Kit	1.2, 1.3 CDTI 16V, 1.4	with fastening material;	<b>F8-5263</b>	
Top Strut Mounting	1.2, 1.2 16V, 1.3 CDTI 16V, 1.7 DI 16V, 1.7 DTI 16V	Bearing Type: Soft Version;	<b>F8-5448</b>	
Top Strut Mounting	1.2, 1.2 16V, 1.3 CDTI 16V, 1.7 DTI 16V	;	<b>F8-5463</b>	
Engine Mounting	1.2, 1.2 16V	Code: KZ FE	<b>F8-6203</b>	
Rubber Buffer, suspension	All Models		<b>F8-6517</b>	
Engine Mounting	1.3 CDTI 16V, 1.7 DI 16V, 1.7 DTI 16V		<b>F8-6753</b>	
Belt Pulley, crankshaft	1.7 DI 16V	Engine 614508, 614509→; Engine →614508; Number of Ribs: 6	<b>F8-7089</b>	
Belt Pulley, crankshaft	1.7 DTI 16V	Number of Ribs: 6	<b>F8-7089</b>	
Protective Cap/Bellow, shock absorber	1.2		<b>F8-7663</b>	H=205
Rubber Buffer, suspension	1.2, 1.2 16V, 1.3 CDTI 16V, 1.7 CDTI, 1.7 DI 16V, 1.7 DTI 16V		<b>F8-7698</b>	H=63
Engine Mounting	1.2, 1.2 16V, 1.4		<b>F8-7793</b>	
Engine Mounting	1.2, 1.2 16V, 1.4		<b>F8-7794</b>	
Stabiliser Mounting	1.2 16V		<b>F8-7929</b>	d=15
Repair Kit, suspension strut	All Models		<b>F8-8085</b>	
Engine Mounting	1.2, 1.2 16V, 1.7 DI 16V, 1.7 DTI 16V		<b>F8-8158</b>	
Engine Mounting	1.2, 1.2 16V		<b>F8-8161</b>	
<b>CORSA D</b>			<b>07/2006 →</b>	
Dust Cover Kit, shock absorber	1.0, 1.2, 1.3 CDTI, 1.4 LPG, 1.6 Turbo, 1.7 CDTI		<b>AK-735250</b>	
Alternator Freewheel Clutch	1.3 CDTI		<b>F5-1041</b>	
Alternator Freewheel Clutch	1.3 CDTI		<b>F5-1045</b>	
Alternator Freewheel Clutch	1.7 CDTI		<b>F5-1049</b>	
Alternator Freewheel Clutch	1.4, 1.4 LPG		<b>F5-1135</b>	
Control Arm-/Trailing Arm Bush	1.0, 1.2, 1.3 CDTI, 1.4 LPG, 1.6 Turbo, 1.7 CDTI		<b>F8-6729</b>	d=12.5; D=66
Top Strut Mounting	1.0, 1.2, 1.2 LPG, 1.3 CDTI, 1.4, 1.4 LPG, 1.6 Turbo, 1.7 CDTI		<b>F8-7421</b>	
Spring Cap	1.0, 1.2, 1.2 LPG, 1.3 CDTI, 1.4, 1.4 LPG, 1.6 Turbo, 1.7 CDTI		<b>F8-7422</b>	
Top Strut Mounting	1.0, 1.2, 1.2 LPG, 1.3 CDTI, 1.4, 1.4 LPG, 1.6 Turbo, 1.7 CDTI		<b>F8-7423</b>	
Top Strut Mounting	1.0, 1.2, 1.2 LPG, 1.3 CDTI, 1.4, 1.4 LPG, 1.6 Turbo, 1.7 CDTI		<b>F8-7424</b>	
Rubber Buffer, suspension	1.0, 1.2, 1.3 CDTI, 1.4, 1.7 CDTI	<b>ST</b>	<b>F8-7661</b>	H=70

<b>AK-735250</b>	<b>F5-1041</b>	<b>F5-1045</b>	<b>F5-1049</b>	<b>F5-1135</b>	<b>F8-5263</b>	<b>F8-5448</b>
Ref.Nr.:	Ref.Nr.: 77364723	Ref.Nr.: 77362721	Ref.Nr.: 1204366	Ref.Nr.: 1204184	Ref.Nr.: 352309	Ref.Nr.: 0344523
<b>F8-5463</b>	<b>F8-6203</b>	<b>F8-6517</b>	<b>F8-6729</b>	<b>F8-6753</b>	<b>F8-7089</b>	<b>F8-7421</b>
Ref.Nr.: 0344525	Ref.Nr.: 24416554	Ref.Nr.: 90468618	Ref.Nr.: 352864	Ref.Nr.: 0684238	Ref.Nr.: 5614444	Ref.Nr.: 51813225
<b>F8-7422</b>	<b>F8-7423</b>	<b>F8-7424</b>	<b>F8-7661</b>	<b>F8-7662</b>	<b>F8-7663</b>	<b>F8-7698</b>
Ref.Nr.: 344963	Ref.Nr.: 55701902	Ref.Nr.: 55703318	Ref.Nr.: 13197623	Ref.Nr.: 0344956	Ref.Nr.: 344435	Ref.Nr.: 24403535

**Article Description****Article Nr.****Fitting Position**

<b>CORSA D</b>			<b>07/2006 →</b>		
Rubber Buffer, suspension	1.0, 1.2, 1.2 LPG, 1.3 CDTI, 1.4, 1.6 Turbo, 1.7 CDTI	SP	F8-7662		H=40
Rubber Buffer, suspension	1.2 LPG, 1.4, 1.4 LPG		F8-7662		H=40
Protective Cap/Bellow, shock absorber	1.0, 1.2, 1.2 LPG, 1.3 CDTI, 1.4, 1.4 LPG, 1.6 Turbo, 1.7 CDTI		F8-7663		H=205
Belt Pulley, crankshaft	1.7 CDTI	Number of Ribs: 5; Parameter: 6PK	F8-7872		Belt Pulley Ø [mm]=149; H1=22; H2=32
<b>CORSA D Van</b>			<b>07/2006 →</b>		
Alternator Freewheel Clutch	1.3 CDTI		F5-1041		
Alternator Freewheel Clutch	1.3 CDTI		F5-1045		
Top Strut Mounting	1.0, 1.2, 1.3 CDTI		F8-7421		
Spring Cap	All Models		F8-7422		
Rubber Buffer, suspension	1.0, 1.2, 1.3 CDTI		F8-7662		H=40
Protective Cap/Bellow, shock absorber	1.0, 1.2, 1.3 CDTI		F8-7663		H=205
Stabiliser Mounting	1.2		F8-7929		d=15
Repair Kit, suspension strut	1.2, 1.3 CDTI	Bearing Type: Hard Version;	F8-8214		
<b>FRONTERA A (5_MWL4)</b>			<b>03/1992 → 10/1998</b>		
Mounting, alternator	2.4 i		F8-5366		
<b>FRONTERA A Sport (5_SUD2)</b>			<b>03/1992 → 10/1998</b>		
Mounting, alternator	2.0 i		F7-2054		H=27; d=8; D1=18; D2=22
<b>FRONTERA B (6B_)</b>			<b>10/1998 → 09/2002</b>		
Belt Pulley, crankshaft	2.2 DTI		F8-5639		
<b>INSIGNIA</b>			<b>07/2008 →</b>		
Dust Cover Kit, shock absorber	1.4, 1.6, 1.6 Turbo, 1.8, 2.0 Biturbo CDTI, 2.0 Biturbo CDTI 4x4, 2.0 CDTI, 2.0 CDTI 4x4, 2.0 E85 Turbo, 2.0 Turbo, 2.0 Turbo 4x4, 2.8 V6 Turbo 4x4, 2.8 V6 Turbo OPC 4x4	SP, ST	AK-735434		
Top Strut Mounting	1.4, 1.6, 1.6 Turbo, 1.8, 2.0 Biturbo CDTI, 2.0 Biturbo CDTI 4x4, 2.0 CDTI, 2.0 CDTI 4x4, 2.0 E85 Turbo, 2.0 Turbo, 2.0 Turbo 4x4, 2.8 V6 Turbo 4x4, 2.8 V6 Turbo OPC 4x4	SP, ST	F8-7611		
Top Strut Mounting	1.4, 1.6, 1.6 Turbo, 1.8, 2.0 Biturbo CDTI, 2.0 Biturbo CDTI 4x4, 2.0 CDTI, 2.0 CDTI 4x4, 2.0 E85 Turbo, 2.0 Turbo, 2.0 Turbo 4x4, 2.8 V6 Turbo 4x4, 2.8 V6 Turbo OPC 4x4	SP, ST	F8-7612		
Top Strut Mounting	1.4, 1.6, 1.6 Turbo, 1.8, 2.0 Biturbo CDTI, 2.0 Biturbo CDTI 4x4, 2.0 CDTI, 2.0 CDTI 4x4, 2.0 E85 Turbo, 2.0 Turbo, 2.0 Turbo 4x4, 2.8 V6 Turbo 4x4, 2.8 V6 Turbo OPC 4x4	SP, ST	F8-7613		

<b>AK-735434</b>	<b>F5-1041</b>	<b>F5-1045</b>	<b>F7-2054</b>	<b>F8-5366</b>	<b>F8-5639</b>	<b>F8-7421</b>
Ref.Nr.: 13243574	Ref.Nr.: 77364723	Ref.Nr.: 77362721	Ref.Nr.: 1204879	Ref.Nr.: 1204885	Ref.Nr.: 0614411	Ref.Nr.: 51813225
<b>F8-7422</b>	<b>F8-7611</b>	<b>F8-7612</b>	<b>F8-7613</b>	<b>F8-7615</b>	<b>F8-7662</b>	<b>F8-7663</b>
Ref.Nr.: 344963	Ref.Nr.: 0344469	Ref.Nr.: 436426	Ref.Nr.: 436427	Ref.Nr.: 436503	Ref.Nr.: 0344956	Ref.Nr.: 344435
<b>F8-7872</b>	<b>F8-7929</b>	<b>F8-8214</b>				
Ref.Nr.: 614758	Ref.Nr.: 350104	Ref.Nr.: 312510				

Article Description



Article Nr.

Fitting Position



<b>INSIGNIA</b>			<b>07/2008 →</b>		
Rubber Buffer, suspension	2.0 Biturbo CDTI 4x4, 2.0 CDTI 4x4, 2.0 Turbo 4x4, 2.8 V6 Turbo 4x4, 2.8 V6 Turbo OPC 4x4	; for vehicles with FlexRide suspension, , ,	<b>F8-7615</b>		
Rubber Buffer, suspension	1.4, 1.4 LPG, 1.6, 1.6 Turbo, 1.8, 2.0 Biturbo CDTI, 2.0 CDTI, 2.0 E85 Turbo, 2.0 Turbo	, ,	<b>F8-7810</b>		H=30
Rubber Buffer, suspension	2.0 Biturbo CDTI 4x4, 2.0 CDTI 4x4, 2.0 Turbo 4x4, 2.8 V6 Turbo 4x4, 2.8 V6 Turbo OPC 4x4	,	<b>F8-7810</b>		H=30
Protective Cap/Bellow, shock absorber	1.4, 1.4 LPG, 1.6, 1.6 Turbo, 1.8, 2.0 Biturbo CDTI, 2.0 Biturbo CDTI 4x4, 2.0 CDTI, 2.0 CDTI 4x4, 2.0 E85 Turbo, 2.0 Turbo, 2.0 Turbo 4x4, 2.8 V6 Turbo 4x4, 2.8 V6 Turbo OPC 4x4	, ,	<b>F8-7811</b>		H=195
Rubber Buffer, suspension	1.4, 1.6, 1.6 Turbo, 1.8, 2.0 Biturbo CDTI, 2.0 CDTI, 2.0 E85 Turbo, 2.0 Turbo	, , , , for vehicles without FlexRide suspension	<b>F8-7889</b>		
<b>INSIGNIA Estate</b>			<b>07/2008 →</b>		
Dust Cover Kit, shock absorber	1.4, 1.6, 1.6 Turbo, 1.8, 2.0 Biturbo CDTI, 2.0 Biturbo CDTI 4x4, 2.0 CDTI, 2.0 CDTI 4x4, 2.0 E85 Turbo, 2.0 Turbo, 2.0 Turbo 4x4, 2.8 V6 Turbo 4x4, 2.8 V6 Turbo OPC 4x4	, ,	<b>AK-735434</b>		
Top Strut Mounting	1.4, 1.6, 1.6 Turbo, 1.8, 2.0 Biturbo CDTI, 2.0 Biturbo CDTI 4x4, 2.0 CDTI, 2.0 CDTI 4x4, 2.0 E85 Turbo, 2.0 Turbo, 2.0 Turbo 4x4, 2.8 V6 Turbo 4x4, 2.8 V6 Turbo OPC 4x4	, , ,	<b>F8-7611</b>		
Top Strut Mounting	1.4, 1.6, 1.6 Turbo, 1.8, 2.0 Biturbo CDTI, 2.0 Biturbo CDTI 4x4, 2.0 CDTI, 2.0 CDTI 4x4, 2.0 E85 Turbo, 2.0 Turbo, 2.0 Turbo 4x4, 2.8 V6 Turbo 4x4, 2.8 V6 Turbo OPC 4x4	, , ,	<b>F8-7612</b>		
Top Strut Mounting	1.4, 1.6, 1.6 Turbo, 1.8, 2.0 Biturbo CDTI, 2.0 Biturbo CDTI 4x4, 2.0 CDTI, 2.0 CDTI 4x4, 2.0 E85 Turbo, 2.0 Turbo, 2.0 Turbo 4x4, 2.8 V6 Turbo 4x4, 2.8 V6 Turbo OPC 4x4	, , ,	<b>F8-7613</b>		
Rubber Buffer, suspension	2.0 Biturbo CDTI 4x4, 2.0 CDTI 4x4, 2.0 Turbo 4x4, 2.8 V6 Turbo 4x4		<b>F8-7615</b>		
Rubber Buffer, suspension	1.4, 1.4 LPG, 1.6, 1.6 Turbo, 1.8, 2.0 Biturbo CDTI, 2.0 CDTI, 2.0 E85 Turbo, 2.0 Turbo	, ,	<b>F8-7810</b>		H=30
Rubber Buffer, suspension	2.0 Biturbo CDTI 4x4, 2.0 CDTI 4x4, 2.0 Turbo 4x4, 2.8 V6 Turbo 4x4, 2.8 V6 Turbo OPC 4x4	,	<b>F8-7810</b>		H=30
Protective Cap/Bellow, shock absorber	1.4, 1.4 LPG, 1.6, 1.6 Turbo, 1.8, 2.0 Biturbo CDTI, 2.0 Biturbo CDTI 4x4, 2.0 CDTI, 2.0 CDTI 4x4, 2.0 E85 Turbo, 2.0 Turbo, 2.0 Turbo 4x4, 2.8 V6 Turbo 4x4, 2.8 V6 Turbo OPC 4x4	, ,	<b>F8-7811</b>		H=195
Rubber Buffer, suspension	1.4, 1.6, 1.6 Turbo, 1.8, 2.0 Biturbo CDTI, 2.0 CDTI, 2.0 E85 Turbo, 2.0 Turbo	, , , , for vehicles without FlexRide suspension	<b>F8-7889</b>		
<b>INSIGNIA Saloon</b>			<b>07/2008 →</b>		
Dust Cover Kit, shock absorber	1.4, 1.6, 1.6 Turbo, 1.8, 2.0 Biturbo CDTI, 2.0 Biturbo CDTI 4x4, 2.0 CDTI, 2.0 CDTI 4x4, 2.0 Turbo, 2.0 Turbo 4x4, 2.0 Turbo E85, 2.8 V6 Turbo 4x4, 2.8 V6 Turbo OPC 4x4	, ,	<b>AK-735434</b>		

<b>AK-735434</b>	<b>F8-7611</b>	<b>F8-7612</b>	<b>F8-7613</b>	<b>F8-7615</b>	<b>F8-7810</b>	<b>F8-7811</b>
Ref.Nr.: 13243574	Ref.Nr.: 0344469	Ref.Nr.: 436426	Ref.Nr.: 436427	Ref.Nr.: 436503	Ref.Nr.: 13257624	Ref.Nr.: 344969
<b>F8-7889</b>						
Ref.Nr.: 436504						

**Article Description****Article Nr.****Fitting Position**

<b>INSIGNIA Saloon</b>		<b>07/2008 →</b>	
Top Strut Mounting	1.4, 1.6, 1.6 Turbo, 1.8, 2.0 Biturbo CDTI, 2.0 Biturbo CDTI 4x4, 2.0 CDTI, 2.0 CDTI 4x4, 2.0 Turbo, 2.0 Turbo 4x4, 2.0 Turbo E85, 2.8 V6 Turbo 4x4, 2.8 V6 Turbo OPC 4x4	<b>SP, ST</b>	<b>F8-7611</b>
Top Strut Mounting	1.4, 1.6, 1.6 Turbo, 1.8, 2.0 Biturbo CDTI, 2.0 Biturbo CDTI 4x4, 2.0 CDTI, 2.0 CDTI 4x4, 2.0 Turbo, 2.0 Turbo 4x4, 2.0 Turbo E85, 2.8 V6 Turbo 4x4, 2.8 V6 Turbo OPC 4x4	<b>SP, ST</b>	<b>F8-7612</b>
Top Strut Mounting	1.4, 1.6, 1.6 Turbo, 1.8, 2.0 Biturbo CDTI, 2.0 Biturbo CDTI 4x4, 2.0 CDTI, 2.0 CDTI 4x4, 2.0 Turbo, 2.0 Turbo 4x4, 2.0 Turbo E85, 2.8 V6 Turbo 4x4, 2.8 V6 Turbo OPC 4x4	<b>SP, ST</b>	<b>F8-7613</b>
Rubber Buffer, suspension	2.0 Biturbo CDTI 4x4, 2.0 CDTI 4x4, 2.0 Turbo 4x4, 2.8 V6 Turbo 4x4, 2.8 V6 Turbo OPC 4x4	<b>SP</b> ; for vehicles with FlexRide suspension, <b>SP</b>	<b>F8-7615</b>
Rubber Buffer, suspension	1.4, 1.4 LPG, 1.6, 1.6 Turbo, 1.8, 2.0 Biturbo CDTI, 2.0 CDTI, 2.0 Turbo, 2.0 Turbo E85	<b>SP, ST</b>	<b>F8-7810</b> H=30
Rubber Buffer, suspension	2.0 Biturbo CDTI 4x4, 2.0 CDTI 4x4, 2.0 Turbo 4x4, 2.8 V6 Turbo 4x4, 2.8 V6 Turbo OPC 4x4	<b>SP, ST</b>	<b>F8-7810</b> H=30
Protective Cap/Bellow, shock absorber	1.4, 1.4 LPG, 1.6, 1.6 Turbo, 1.8, 2.0 Biturbo CDTI, 2.0 Biturbo CDTI 4x4, 2.0 CDTI, 2.0 CDTI 4x4, 2.0 Turbo, 2.0 Turbo 4x4, 2.0 Turbo E85, 2.8 V6 Turbo 4x4, 2.8 V6 Turbo OPC 4x4	<b>SP, ST</b>	<b>F8-7811</b> H=195
Rubber Buffer, suspension	1.4, 1.6, 1.6 Turbo, 1.8, 2.0 Biturbo CDTI, 2.0 CDTI, 2.0 Turbo, 2.0 Turbo E85	<b>SP, ST</b> ; for vehicles without FlexRide suspension	<b>F8-7889</b>
<b>KADETT C</b>		<b>08/1973 → 07/1979</b>	
Mounting, alternator	All Models		<b>F7-2055</b> H=9; d=8; D=26
Stabiliser Mounting	1.2, 1.2 S	ch.Y2000001, Y5000001→	<b>F8-5230</b> d=18
Mounting, stabilizer coupling rod	All Models		<b>F8-5333</b> d=8.5; D=30
<b>KADETT C Estate</b>		<b>08/1973 → 07/1979</b>	
Mounting, alternator	All Models		<b>F7-2055</b> H=9; d=8; D=26
Stabiliser Mounting	1.2, 1.2 S	ch.Y2000001, Y5000001→	<b>F8-5230</b> d=18
Mounting, stabilizer coupling rod	All Models		<b>F8-5333</b> d=8.5; D=30
<b>KADETT C City</b>		<b>08/1973 → 07/1979</b>	
Mounting, alternator	All Models		<b>F7-2055</b> H=9; d=8; D=26
Stabiliser Mounting	1.2, 1.2 S	ch.Y2000001, Y5000001→	<b>F8-5230</b> d=18
Mounting, stabilizer coupling rod	All Models		<b>F8-5333</b> d=8.5; D=30
<b>KADETT C Coupe</b>		<b>08/1973 → 07/1979</b>	
Mounting, alternator	All Models		<b>F7-2055</b> H=9; d=8; D=26
Stabiliser Mounting	1.2, 1.2 S	ch.Y2000001, Y5000001→	<b>F8-5230</b> d=18

<b>F7-2055</b>	<b>F8-5230</b>	<b>F8-5333</b>	<b>F8-7611</b>	<b>F8-7612</b>	<b>F8-7613</b>	<b>F8-7615</b>
Ref.Nr.: 1204892	Ref.Nr.: 0350138	Ref.Nr.: 2875013	Ref.Nr.: 0344469	Ref.Nr.: 436426	Ref.Nr.: 436427	Ref.Nr.: 436503
<b>F8-7810</b>	<b>F8-7811</b>	<b>F8-7889</b>				
Ref.Nr.: 13257624	Ref.Nr.: 344969	Ref.Nr.: 436504				

Article Description

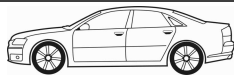

Article Nr.

Fitting Position



<b>KADETT C Coupe</b>		<b>08/1973 → 07/1979</b>	
Mounting, stabilizer coupling rod	All Models	F8-5333	d=8.5; D=30
<b>KADETT D (31_-34_, 41_-44_)</b>		<b>08/1979 → 08/1984</b>	
Dust Cover Kit, shock absorber	1.2, 1.2 S, 1.3 N, 1.3 S, 1.6 D, 1.6 S, 1.8 GT/E	AK-735003	
Mounting, alternator	1.2, 1.2 S, 1.3 N, 1.3 S, 1.6 D, 1.6 S, 1.8 GT/E	F7-2055	H=9; d=8; D=26
Mounting, axle beam	1.2, 1.2 S, 1.3 N, 1.3 S, 1.6 D, 1.6 S, 1.8 GT/E	F8-3060	H=75; d=12; D1=49; D2=57
Stabiliser Mounting	1.2, 1.2 S	ch.Y2000001, Y5000001→	F8-5230  d=18
Mounting, stabilizer coupling rod	1.2, 1.2 S, 1.3 N, 1.3 S, 1.6 D, 1.6 S, 1.8 GT/E	F8-5333	d=8.5; D=30
Mounting, alternator	1.0, 1.2 S	Engine0652529→	F8-5366
Mounting, alternator	1.2, 1.3 N, 1.3 S	Engine1073534→	F8-5366
Control Arm-/Trailing Arm Bush	1.2, 1.2 S, 1.3 N, 1.3 S, 1.6 D, 1.6 S, 1.8 GT/E	G9-591	H=59; d=14.5; D1=39; D2=44
Control Arm-/Trailing Arm Bush	1.2, 1.2 S, 1.3 N, 1.3 S, 1.6 D, 1.6 S, 1.8 GT/E	G9-592	H=54; d=6; d1=6; d2=23
Bellow, steering	1.2, 1.2 S, 1.3 N, 1.3 S, 1.6 D, 1.6 S, 1.8 GT/E	with clamps	LM-10045S  d1=42; d2=52; L [mm]=165
Bellow Set, drive shaft	1.2, 1.2 S, 1.3 N, 1.3 S	M-820820	
Bellow, steering	1.2, 1.2 S, 1.3 N, 1.3 S, 1.6 D, 1.6 S, 1.8 GT/E	M-822300	
C.V. Boot	1.6, 1.6 D, 1.8 GT/E	ch.N1000001, N2000001, N5000001→; ch.→N2733477, N5273484, P8202125	M-822900
Bellow Set, drive shaft	1.2, 1.2 S, 1.3 N, 1.3 S	MK-820820	
Bellow, steering	1.2, 1.2 S, 1.3 N, 1.3 S, 1.6 D, 1.6 S, 1.8 GT/E	MK-822300	H=165; d1=42; d2=52
Repair Kit, steering gear	1.2, 1.2 S, 1.3 N, 1.3 S, 1.6 D, 1.6 S, 1.8 GT/E	MK-822300S	
Bellow Set, drive shaft	1.2, 1.2 S, 1.3 N, 1.3 S, 1.6 D, 1.6 S, 1.8 GT/E	MK-822920	
<b>KADETT D Estate (35_, 36_, 45_, 46_)</b>		<b>08/1979 → 08/1984</b>	
Dust Cover Kit, shock absorber	1.2, 1.2 S, 1.3 N, 1.3 S, 1.6 D, 1.6 S	AK-735003	
Mounting, alternator	1.2, 1.2 S, 1.3 N, 1.3 S, 1.6 D, 1.6 S	F7-2055	H=9; d=8; D=26
Mounting, axle beam	1.2, 1.2 S, 1.3 N, 1.3 S, 1.6 D, 1.6 S	F8-3060	H=75; d=12; D1=49; D2=57
Stabiliser Mounting	1.2, 1.2 S	ch.Y2000001, Y5000001→	F8-5230  d=18
Mounting, stabilizer coupling rod	1.2, 1.2 S, 1.3 N, 1.3 S, 1.6 D, 1.6 S	F8-5333	d=8.5; D=30
Mounting, alternator	1.2 S	Engine0652529→	F8-5366
Mounting, alternator	1.3 N, 1.3 S	Engine1073534→	F8-5366
Control Arm-/Trailing Arm Bush	1.2, 1.2 S, 1.3 N, 1.3 S, 1.6 D, 1.6 S	G9-591	H=59; d=14.5; D1=39; D2=44
Control Arm-/Trailing Arm Bush	1.2, 1.2 S, 1.3 N, 1.3 S, 1.6 D, 1.6 S	G9-592	H=54; d=6; d1=6; d2=23

<b>AK-735003</b>	<b>F7-2055</b>	<b>F8-3060</b>	<b>F8-5230</b>	<b>F8-5333</b>	<b>F8-5366</b>	<b>G9-591</b>
Ref.Nr.:	Ref.Nr.: 1204892	Ref.Nr.: 90189050	Ref.Nr.: 0350138	Ref.Nr.: 2875013	Ref.Nr.: 1204885	Ref.Nr.: 90193117
<b>G9-592</b>	<b>LM-10045S</b>		<b>M-822300</b>	<b>M-822900</b>	<b>MK-820820</b>	<b>MK-822300</b>
Ref.Nr.: 352335	Ref.Nr.: 26024585	Ref.Nr.: 1603146	Ref.Nr.: 90090811	Ref.Nr.: 90421747	Ref.Nr.: 1603179	Ref.Nr.: 90345195
<b>MK-822300S</b>	<b>MK-822920</b>					
Ref.Nr.: 902828	Ref.Nr.: 811498203					

**Article Description****Article Nr.****Fitting Position**

<b>KADETT D Estate (35_, 36_, 45_, 46_)</b>			<b>08/1979 → 08/1984</b>	
Bellow, steering	1.2, 1.2 S, 1.3 N, 1.3 S, 1.6 D, 1.6 S	with clamps	<b>LM-10045S</b>	d1=42; d2=52; L [mm]=165
Bellow Set, drive shaft	1.2, 1.2 S, 1.3 N, 1.3 S		<b>M-820820</b>	
Bellow, steering	1.2, 1.2 S, 1.3 N, 1.3 S, 1.6 D, 1.6 S		<b>M-822300</b>	
C.V. Boot	1.6, 1.6 D	ch.N1000001, N2000001, N5000001→; ch.→N2733477, N5273484, P8202125	<b>M-822900</b>	
Bellow Set, drive shaft	1.2, 1.2 S, 1.3 N, 1.3 S		<b>MK-820820</b>	
Bellow, steering	1.2, 1.2 S, 1.3 N, 1.3 S, 1.6 D, 1.6 S		<b>MK-822300</b>	H=165; d1=42; d2=52
Repair Kit, steering gear	1.2, 1.2 S, 1.3 N, 1.3 S, 1.6 D, 1.6 S		<b>MK-822300S</b>	
Bellow Set, drive shaft	1.2, 1.2 S, 1.3 N, 1.3 S, 1.6 D, 1.6 S		<b>MK-822920</b>	
<b>KADETT E (39_, 49_)</b>			<b>09/1984 → 08/1991</b>	
Dust Cover Kit, shock absorber	1.2, 1.3 i CAT, 1.3 N, 1.3 S, 1.4 i, 1.4 S, 1.5 TD, 1.6 D, 1.6 i, 1.6 i CAT, 1.6 S, 1.7 D, 1.8, 1.8 i, 1.8 S, 2.0 i, 2.0 i CAT		<b>AK-735003</b>	
Mounting, alternator	1.2, 1.3 i CAT, 1.3 N, 1.3 S, 1.6 D, 1.6 S, 1.8 i		<b>F7-2055</b>	H=9; d=8; D=26
Top Strut Mounting	1.5 TD, 1.6 D, 1.6 S, 1.7 D, 1.8 i, 1.8 S, 2.0 i, 2.0 i CAT		<b>F8-3059</b>	d1=14; d2=37; D=78; $\tau$ [mm]=132
Mounting, axle beam	1.2, 1.3 i CAT, 1.3 N, 1.3 S, 1.4 i, 1.4 S, 1.5 TD, 1.6 D, 1.6 i, 1.6 i CAT, 1.6 S, 1.7 D, 1.8, 1.8 i, 1.8 S, 2.0 i, 2.0 i CAT		<b>F8-3060</b>	H=75; d=12; D1=49; D2=57
Mounting, axle beam	1.2, 1.3 i CAT, 1.3 N, 1.3 S, 1.4 i, 1.4 S, 1.5 TD, 1.6 D, 1.6 i, 1.6 i CAT, 1.6 S, 1.7 D, 1.8 i, 1.8 S, 2.0 i, 2.0 i CAT	ch.N2500001→	<b>F8-4102</b>	H=74; d=12; D1=60; D2=66
Mounting, axle beam	1.8, 1.8 i		<b>F8-4102</b>	H=74; d=12; D1=60; D2=66
Control Arm-/Trailing Arm Bush	2.0 i, 2.0 i CAT		<b>F8-5107</b>	H=54; d1=6; d2=23
Stabiliser Mounting	1.2, 1.3 i CAT, 1.3 N, 1.3 S, 1.4 i, 1.4 S, 1.5 TD, 1.6 D, 1.6 i, 1.6 i CAT, 1.6 S, 1.7 D, 1.8, 1.8 i, 1.8 S, 2.0 i, 2.0 i CAT		<b>F8-5143</b>	d=17.5
Stabiliser Mounting	1.2, 1.3 i CAT, 1.3 N, 1.3 S, 1.4 i, 1.4 S, 1.5 TD, 1.6 D, 1.6 i, 1.6 i CAT, 1.6 S, 1.7 D, 1.8 i, 1.8 S, 2.0 i, 2.0 i CAT		<b>F8-5144</b>	D=20; d=20
Stabiliser Mounting	1.2	ch.Y2000001, Y5000001→	<b>F8-5230</b>	d=18
Mounting, stabilizer coupling rod	1.2, 1.3 i CAT, 1.3 N, 1.3 S, 1.4 i, 1.4 S, 1.5 TD, 1.6 D, 1.6 i, 1.6 i CAT, 1.6 S, 1.7 D, 1.8, 1.8 i, 1.8 S, 2.0 i, 2.0 i CAT		<b>F8-5333</b>	d=8.5; D=30
Mounting, alternator	1.2, 1.3 i CAT, 1.3 N, 1.3 S		<b>F8-5366</b>	
Mounting, alternator	1.4 i, 1.4 S		<b>F8-5366</b>	
Mounting, alternator	1.6 i, 1.6 i CAT, 1.6 S		<b>F8-5366</b>	
Top Strut Mounting	1.2, 1.3 i CAT, 1.3 N, 1.3 S, 1.4 i, 1.4 S, 1.6 i, 1.6 i CAT, 1.6 S		<b>F8-5589</b>	
Rubber Buffer, suspension	All Models		<b>F8-5611</b>	

<b>AK-735003</b>	<b>F7-2055</b>	<b>F8-3059</b>	<b>F8-3060</b>	<b>F8-4102</b>	<b>F8-5107</b>	<b>F8-5143</b>
Ref.Nr.:	Ref.Nr.: 1204892	Ref.Nr.: 344509	Ref.Nr.: 90189050	Ref.Nr.: 90372559	Ref.Nr.: 0352338	Ref.Nr.: 0350112
<b>F8-5144</b>	<b>F8-5230</b>	<b>F8-5333</b>	<b>F8-5366</b>	<b>F8-5589</b>	<b>F8-5611</b>	<b>F8-7584</b>
Ref.Nr.: 0350113	Ref.Nr.: 0350138	Ref.Nr.: 2875013	Ref.Nr.: 1204885	Ref.Nr.: 344508	Ref.Nr.: 0436940	Ref.Nr.: 0344401
<b>LM-10045S</b>	<b>M-820820</b>	<b>M-822300</b>	<b>M-822900</b>	<b>MK-820820</b>	<b>MK-822300</b>	<b>MK-822300S</b>
Ref.Nr.: 26024585	Ref.Nr.: 1603146	Ref.Nr.: 90090811	Ref.Nr.: 90421747	Ref.Nr.: 1603179	Ref.Nr.: 90345195	Ref.Nr.: 902828

Article Description

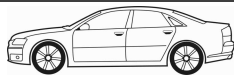

Article Nr.

Fitting Position



## KADETT E (39\_, 49\_)

09/1984 → 08/1991

Rubber Buffer, suspension	1.2, 1.3 i CAT, 1.3 N, 1.3 S, 1.4 i, 1.4 S, 1.5 TD, 1.6 D, 1.6 i, 1.6 i CAT, 1.6 S, 1.7 D, 1.8, 1.8 i, 1.8 S, 2.0 i, 2.0 i CAT	ST	F8-7584		H=68
Engine Mounting	1.2, 1.3 i CAT, 1.3 N, 1.3 S, 1.4 i, 1.4 S, 1.6 D, 1.6 i, 1.6 i CAT, 1.6 S, 1.7 D, 1.8, 1.8 i		F8-8145		
Control Arm-/Trailing Arm Bush	1.2, 1.3 i CAT, 1.3 N, 1.3 S, 1.4 i, 1.4 S, 1.5 TD, 1.6 D, 1.6 i, 1.6 i CAT, 1.6 S, 1.7 D, 1.8, 1.8 i, 1.8 S, 2.0 i, 2.0 i CAT		G9-591		H=59; d=14.5; D1=39; D2=44
Control Arm-/Trailing Arm Bush	1.2, 1.3 i CAT, 1.3 N, 1.3 S, 1.4 i, 1.4 S, 1.5 TD, 1.6 D, 1.6 i, 1.6 i CAT, 1.6 S, 1.7 D, 1.8, 1.8 i, 1.8 S, 2.0 i, 2.0 i CAT		G9-592		H=54; d=6; d1=6; d2=23
Bellow, steering	All Models	with clamps	LM-10045S		d1=42; d2=52; L [mm]=165
Bellow Set, drive shaft	1.2, 1.3 i CAT, 1.3 N, 1.3 S, 1.4 i, 1.4 S, 1.6 D, 1.6 i, 1.6 i CAT, 1.6 S		M-820820		
Bellow, steering	All Models		M-822300		
C.V. Boot	1.5 TD, 1.6 D, 1.7 D, 1.8, 1.8 i, 1.8 S, 2.0 i, 2.0 i CAT	ch.N1000001, N2000001, N5000001→; ch.→N2733477, N5273484, P8202125	M-822900		
Bellow Set, drive shaft	1.2, 1.3 i CAT, 1.3 N, 1.3 S, 1.4 i, 1.4 S, 1.6 i, 1.6 i CAT, 1.6 S		MK-820820		
Bellow Set, drive shaft	1.6 D, 1.6 S		MK-820820		
Bellow, steering	1.2, 1.3 i CAT, 1.3 N, 1.3 S, 1.4 i, 1.4 S, 1.5 TD, 1.6 D, 1.6 i, 1.6 i CAT, 1.6 S, 1.7 D, 1.8 i, 1.8 S, 2.0 i, 2.0 i CAT		MK-822300		H=165; d1=42; d2=52
Bellow, steering	1.8, 1.8 i		MK-822300		H=165; d1=42; d2=52
Repair Kit, steering gear	1.2, 1.3 i CAT, 1.3 N, 1.3 S, 1.4 i, 1.4 S, 1.5 TD, 1.6 D, 1.6 i, 1.6 i CAT, 1.6 S, 1.7 D, 1.8 i, 1.8 S, 2.0 i, 2.0 i CAT		MK-822300S		
Repair Kit, steering gear	1.8, 1.8 i		MK-822300S		
Bellow Set, drive shaft	1.5 TD, 1.6 i, 1.6 i CAT, 1.6 S, 1.8, 1.8 i, 1.8 S		MK-822920		
Bellow Set, drive shaft	1.6 D, 1.6 S, 1.7 D, 1.8 i, 2.0 i, 2.0 i CAT		MK-822920		

## KADETT E Convertible (43B\_)

10/1986 → 02/1993

Dust Cover Kit, shock absorber	1.3 S, 1.4 i, 1.4 S, 1.6 i, 1.6 i CAT, 2.0 i, 2.0 i CAT		AK-735003		
Mounting, alternator	1.3 S		F7-2055		H=9; d=8; D=26
Mounting, axle beam	1.3 S, 1.6 i, 1.6 i CAT, 2.0 i, 2.0 i CAT	ch.→NB547665	F8-3060		H=75; d=12; D1=49; D2=57
Mounting, axle beam	1.4 i, 1.4 S		F8-3060		H=75; d=12; D1=49; D2=57
Mounting, axle beam	1.3 S, 1.6 i, 1.6 i CAT, 2.0 i, 2.0 i CAT	ch.NB547666→	F8-4102		H=74; d=12; D1=60; D2=66
Mounting, axle beam	1.4 i, 1.4 S		F8-4102		H=74; d=12; D1=60; D2=66
Control Arm-/Trailing Arm Bush	2.0 i, 2.0 i CAT		F8-5107		H=54; d1=6; d2=23
Stabiliser Mounting	1.3 S, 1.4 i, 1.4 S, 1.6 i, 1.6 i CAT, 2.0 i, 2.0 i CAT		F8-5143		d=17.5

<b>AK-735003</b>	<b>F7-2055</b>	<b>F8-3060</b>	<b>F8-4102</b>	<b>F8-5107</b>	<b>F8-5143</b>	<b>F8-5144</b>
Ref.Nr.: _____	Ref.Nr.: 1204892	Ref.Nr.: 90189050	Ref.Nr.: 90372559	Ref.Nr.: 0352338	Ref.Nr.: 0350112	Ref.Nr.: 0350113
<b>F8-7584</b>	<b>F8-8145</b>	<b>G9-591</b>	<b>G9-592</b>	<b>LM-10045S</b>	<b>M-820820</b>	<b>M-822300</b>
Ref.Nr.: 0344401	Ref.Nr.: 90189509	Ref.Nr.: 90193117	Ref.Nr.: 352335	Ref.Nr.: 26024585	Ref.Nr.: 1603146	Ref.Nr.: 90090811
<b>M-822900</b>	<b>MK-820820</b>	<b>MK-822300</b>	<b>MK-822300S</b>	<b>MK-822920</b>		
Ref.Nr.: 90421747	Ref.Nr.: 1603179	Ref.Nr.: 90345195	Ref.Nr.: 902828	Ref.Nr.: 811498203		



**Article Description****Article Nr.****Fitting Position**

<b>KADETT E Convertible (43B_)</b>		<b>10/1986 → 02/1993</b>	
Stabiliser Mounting	1.3 S, 1.6 i, 1.6 i CAT, 2.0 i, 2.0 i CAT		<b>F8-5144</b>
Mounting, stabilizer coupling rod	1.3 S, 1.4 i, 1.6 i, 1.6 i CAT, 2.0 i CAT		<b>F8-5333</b>
Mounting, alternator	1.3 S		<b>F8-5366</b>
Mounting, alternator	1.4 i		<b>F8-5366</b>
Mounting, alternator	1.6 i, 1.6 i CAT		<b>F8-5366</b>
Top Strut Mounting	1.3 S, 1.4 i, 1.4 S, 1.6 i, 1.6 i CAT		<b>F8-5589</b>
Rubber Buffer, suspension	All Models		<b>F8-5611</b>
Rubber Buffer, suspension	All Models		<b>F8-7584</b>
Engine Mounting	1.3 S, 1.4 i, 1.6 i, 1.6 i CAT, 2.0		<b>F8-8145</b>
Control Arm-/Trailing Arm Bush	1.3 S, 1.4 i, 1.4 S, 1.6 i, 1.6 i CAT, 2.0 i, 2.0 i CAT		<b>G9-591</b>
Control Arm-/Trailing Arm Bush	1.3 S, 1.4 i, 1.4 S, 1.6 i, 1.6 i CAT, 2.0 i, 2.0 i CAT		<b>G9-592</b>
Bellow, steering	All Models	with clamps	<b>LM-10045S</b>
Bellow Set, drive shaft	1.3 S, 1.4 i, 1.4 S, 1.6 i, 1.6 i CAT		<b>M-820820</b>
Bellow, steering	All Models		<b>M-822300</b>
C.V. Boot	2.0 i, 2.0 i CAT	ch.N1000001, N2000001, N5000001→; ch.→N2733477, N5273484, P8202125	<b>M-822900</b>
Bellow Set, drive shaft	1.3 S, 1.6 i, 1.6 i CAT		<b>MK-820820</b>
Bellow Set, drive shaft	1.4 i, 1.4 S		<b>MK-820820</b>
Bellow, steering	1.3 S, 1.6 i, 1.6 i CAT, 2.0 i, 2.0 i CAT		<b>MK-822300</b>
Bellow, steering	1.4 i, 1.4 S		<b>MK-822300</b>
Repair Kit, steering gear	1.3 S, 1.6 i, 1.6 i CAT, 2.0 i, 2.0 i CAT		<b>MK-822300S</b>
Repair Kit, steering gear	1.4 i, 1.4 S		<b>MK-822300S</b>
Bellow Set, drive shaft	1.6 i, 1.6 i CAT		<b>MK-822920</b>
Bellow Set, drive shaft	2.0 i, 2.0 i CAT		<b>MK-822920</b>
<b>KADETT E Estate (35_, 36_, 45_, 46_)</b>		<b>09/1984 → 08/1991</b>	
Dust Cover Kit, shock absorber	1.2, 1.3 i CAT, 1.3 N, 1.3 S, 1.4 i, 1.4 S, 1.5 TD, 1.6, 1.6 D, 1.6 i, 1.6 i CAT, 1.6 S, 1.7 D, 1.8 E, 1.8 i, 1.8 S, 2.0 i, 2.0 i CAT		<b>AK-735003</b>
Mounting, alternator	1.2, 1.3 i CAT, 1.3 N, 1.3 S, 1.6 D, 1.6 S, 1.8 i		<b>F7-2055</b>
Top Strut Mounting	1.5 TD, 1.6 D, 1.6 S, 1.7 D, 1.8 E, 1.8 i, 1.8 S, 2.0 i, 2.0 i CAT		<b>F8-3059</b>
Mounting, axle beam	1.2, 1.3 i CAT, 1.3 N, 1.3 S, 1.4 i, 1.4 S, 1.5 TD, 1.6, 1.6 D, 1.6 i, 1.6 i CAT, 1.6 S, 1.8 E, 1.8 i, 1.8 S, 2.0 i, 2.0 i CAT		<b>F8-3060</b>

<b>AK-735003</b>	<b>F7-2055</b>	<b>F8-3059</b>	<b>F8-3060</b>	<b>F8-5144</b>	<b>F8-5333</b>	<b>F8-5366</b>
Ref.Nr.:	Ref.Nr.: 1204892	Ref.Nr.: 344509	Ref.Nr.: 90189050	Ref.Nr.: 0350113	Ref.Nr.: 2875013	Ref.Nr.: 1204885
<b>F8-5589</b>	<b>F8-5611</b>	<b>F8-7584</b>	<b>F8-8145</b>	<b>G9-591</b>	<b>G9-592</b>	<b>LM-10045S</b>
Ref.Nr.: 344508	Ref.Nr.: 0436940	Ref.Nr.: 0344401	Ref.Nr.: 90189509	Ref.Nr.: 90193117	Ref.Nr.: 352335	Ref.Nr.: 26024585
<b>M-820820</b>	<b>M-822300</b>	<b>M-822900</b>	<b>MK-820820</b>	<b>MK-822300</b>	<b>MK-822300S</b>	<b>MK-822920</b>
Ref.Nr.: 1603146	Ref.Nr.: 90090811	Ref.Nr.: 90421747	Ref.Nr.: 1603179	Ref.Nr.: 90345195	Ref.Nr.: 902828	Ref.Nr.: 811498203

Article Description



Article Nr.

Fitting Position



KADETT E Estate (35_, 36_, 45_, 46_)			09/1984 → 08/1991		
Mounting, axle beam	1.7 D	ch.→N2500000	<b>F8-3060</b>		H=75; d=12; D1=49; D2=57
Mounting, axle beam	1.2, 1.3 i CAT, 1.3 N, 1.3 S, 1.4 i, 1.4 S, 1.5 TD, 1.6, 1.6 D, 1.6 i, 1.6 i CAT, 1.6 S, 1.8 E, 1.8 i, 1.8 S, 2.0 i, 2.0 i CAT		<b>F8-4102</b>		H=74; d=12; D1=60; D2=66
Mounting, axle beam	1.7 D	ch.N2500001→	<b>F8-4102</b>		H=74; d=12; D1=60; D2=66
Stabiliser Mounting	1.2, 1.3 i CAT, 1.3 N, 1.3 S, 1.4 i, 1.4 S, 1.5 TD, 1.6, 1.6 D, 1.6 i, 1.6 i CAT, 1.6 S, 1.7 D, 1.8 E, 1.8 i, 1.8 S, 2.0 i, 2.0 i CAT		<b>F8-5143</b>		d=17.5
Stabiliser Mounting	1.2, 1.3 i CAT, 1.3 N, 1.3 S, 1.4 i, 1.4 S, 1.5 TD, 1.6, 1.6 D, 1.6 i, 1.6 i CAT, 1.6 S, 1.7 D, 1.8 E, 1.8 i, 1.8 S, 2.0 i, 2.0 i CAT		<b>F8-5144</b>		D=20; d=20
Stabiliser Mounting	1.2	ch.Y2000001, Y5000001→	<b>F8-5230</b>		d=18
Mounting, stabilizer coupling rod	1.2, 1.3 i CAT, 1.3 N, 1.3 S, 1.4 i, 1.4 S, 1.5 TD, 1.6, 1.6 D, 1.6 i, 1.6 i CAT, 1.6 S, 1.7 D, 1.8 E, 1.8 i, 1.8 S, 2.0 i, 2.0 i CAT		<b>F8-5333</b>		d=8.5; D=30
Mounting, alternator	1.2, 1.3 i CAT, 1.3 N, 1.3 S		<b>F8-5366</b>		
Mounting, alternator	1.4 i, 1.4 S		<b>F8-5366</b>		
Mounting, alternator	1.6, 1.6 i, 1.6 i CAT		<b>F8-5366</b>		
Top Strut Mounting	1.2, 1.3 i CAT, 1.3 N, 1.3 S, 1.4 i, 1.4 S, 1.6, 1.6 i, 1.6 i CAT, 1.6 S		<b>F8-5589</b>		
Rubber Buffer, suspension	1.2, 1.3, 1.3 i CAT, 1.3 N, 1.3 S, 1.4 i, 1.4 S, 1.5 TD, 1.6, 1.6 D, 1.6 i, 1.6 i CAT, 1.6 S, 1.7 D, 1.8 E, 1.8 i, 1.8 S, 2.0 i, 2.0 i CAT		<b>F8-5611</b>		
Rubber Buffer, suspension	1.2, 1.3 i CAT, 1.3 N, 1.3 S, 1.4 i, 1.4 S, 1.5 TD, 1.6, 1.6 D, 1.6 i, 1.6 i CAT, 1.6 S, 1.7 D, 1.8 E, 1.8 i, 1.8 S, 2.0 i, 2.0 i CAT	<b>ST</b>	<b>F8-7584</b>		H=68
Engine Mounting	1.2, 1.3 i CAT, 1.3 N, 1.3 S, 1.4 i, 1.4 S, 1.6, 1.6 D, 1.6 i, 1.6 i CAT, 1.7 D, 1.8 E, 1.8 i		<b>F8-8145</b>		
Control Arm-/Trailing Arm Bush	1.2, 1.3 i CAT, 1.3 N, 1.3 S, 1.4 i, 1.4 S, 1.5 TD, 1.6, 1.6 D, 1.6 i, 1.6 i CAT, 1.6 S, 1.7 D, 1.8 E, 1.8 i, 1.8 S, 2.0 i, 2.0 i CAT		<b>G9-591</b>		H=59; d=14.5; D1=39; D2=44
Control Arm-/Trailing Arm Bush	1.2, 1.3 i CAT, 1.3 N, 1.3 S, 1.4 i, 1.4 S, 1.5 TD, 1.6, 1.6 D, 1.6 i, 1.6 i CAT, 1.6 S, 1.7 D, 1.8 E, 1.8 i, 1.8 S, 2.0 i, 2.0 i CAT		<b>G9-592</b>		H=54; d=6; d1=6; d2=23
Bellow, steering	1.2, 1.3, 1.3 i CAT, 1.3 N, 1.3 S, 1.4 i, 1.4 S, 1.5 TD, 1.6, 1.6 D, 1.6 i, 1.6 i CAT, 1.6 S, 1.7 D, 1.8 E, 1.8 i, 1.8 S, 2.0 i, 2.0 i CAT	with clamps	<b>LM-10045S</b>		d1=42; d2=52; L [mm]=165
Bellow Set, drive shaft	1.2, 1.3 i CAT, 1.3 N, 1.3 S, 1.4 i, 1.4 S, 1.6, 1.6 D, 1.6 i, 1.6 i CAT, 1.6 S		<b>M-820820</b>		
Bellow, steering	1.2, 1.3, 1.3 i CAT, 1.3 N, 1.3 S, 1.4 i, 1.4 S, 1.5 TD, 1.6, 1.6 D, 1.6 i, 1.6 i CAT, 1.6 S, 1.7 D, 1.8 E, 1.8 i, 1.8 S, 2.0 i, 2.0 i CAT		<b>M-822300</b>		
C.V. Boot	1.5 TD, 1.6 D, 1.7 D, 1.8 E, 1.8 i, 1.8 S, 2.0 i, 2.0 i CAT	ch.N1000001, N2000001, N5000001→; ch.→N2733477, N5273484, P8202125	<b>M-822900</b>		

<b>F8-3060</b>	<b>F8-4102</b>	<b>F8-5143</b>	<b>F8-5144</b>	<b>F8-5230</b>	<b>F8-5333</b>	<b>F8-5366</b>
Ref.Nr.: 90189050	Ref.Nr.: 90372559	Ref.Nr.: 0350112	Ref.Nr.: 0350113	Ref.Nr.: 0350138	Ref.Nr.: 2875013	Ref.Nr.: 1204885
<b>F8-5589</b>	<b>F8-5611</b>	<b>F8-7584</b>	<b>F8-8145</b>	<b>G9-591</b>	<b>G9-592</b>	<b>LM-10045S</b>
Ref.Nr.: 344508	Ref.Nr.: 0436940	Ref.Nr.: 0344401	Ref.Nr.: 90189509	Ref.Nr.: 90193117	Ref.Nr.: 352335	Ref.Nr.: 26024585
<b>M-820820</b>	<b>M-822300</b>	<b>M-822900</b>	<b>MK-820820</b>			
Ref.Nr.: 1603146	Ref.Nr.: 90090811	Ref.Nr.: 90421747	Ref.Nr.: 1603179			

**Article Description****Article Nr.****Fitting Position**

<b>KADETT E Estate (35, 36, 45, 46)</b>		<b>09/1984 → 08/1991</b>	
Bellow Set, drive shaft	1.2, 1.3 i CAT, 1.3 N, 1.3 S, 1.4 i, 1.4 S, 1.6, 1.6 i, 1.6 i CAT		<b>MK-820820</b>
Bellow Set, drive shaft	1.6 D, 1.6 S		<b>MK-820820</b>
Bellow, steering	1.2, 1.3 i CAT, 1.3 N, 1.3 S, 1.4 i, 1.4 S, 1.5 TD, 1.6, 1.6 D, 1.6 i, 1.6 i CAT, 1.6 S, 1.7 D, 1.8 E, 1.8 i, 1.8 S, 2.0 i, 2.0 i CAT		<b>MK-822300</b>
Bellow, steering	1.8 i		<b>MK-822300</b>
Repair Kit, steering gear	1.2, 1.3 i CAT, 1.3 N, 1.3 S, 1.4 i, 1.4 S, 1.5 TD, 1.6, 1.6 D, 1.6 i, 1.6 i CAT, 1.6 S, 1.7 D, 1.8 E, 1.8 i, 1.8 S, 2.0 i, 2.0 i CAT		<b>MK-822300S</b>
Repair Kit, steering gear	1.8 i		<b>MK-822300S</b>
Bellow Set, drive shaft	1.5 TD, 1.6, 1.6 i, 1.6 i CAT, 1.8 i		<b>MK-822920</b>
Bellow Set, drive shaft	1.6 D, 1.6 S, 1.7 D, 1.8 E, 1.8 i, 1.8 S, 2.0 i, 2.0 i CAT		<b>MK-822920</b>
<b>KADETT E Hatchback (33, 34, 43, 44)</b>		<b>09/1984 → 08/1991</b>	
Dust Cover Kit, shock absorber	1.2, 1.3 i CAT, 1.3 N, 1.3 S, 1.4 i, 1.4 S, 1.5 TD, 1.6 D, 1.6 i, 1.6 i CAT, 1.6 S, 1.7 D, 1.8 E, 1.8 GSI, 1.8 i, 1.8 S, 2.0 GSI, 2.0 GSI 16V, 2.0 GSI 16V CAT, 2.0 GSI CAT		<b>AK-735003</b>
Mounting, alternator	1.2, 1.3 i CAT, 1.3 N, 1.3 S, 1.6 D, 1.6 S, 1.8 GSI		<b>F7-2055</b>
Top Strut Mounting	1.5 TD, 1.6 D, 1.6 S, 1.7 D, 1.8 E, 1.8 GSI, 1.8 i, 1.8 S, 2.0 GSI, 2.0 GSI 16V, 2.0 GSI 16V CAT, 2.0 GSI CAT		<b>F8-3059</b>
Mounting, axle beam	1.2, 1.3 i CAT, 1.3 N, 1.3 S, 1.4 i, 1.4 S, 1.5 TD, 1.6 D, 1.6 i, 1.6 i CAT, 1.6 S, 1.7 D, 1.8 E, 1.8 GSI, 1.8 i, 1.8 S, 2.0 GSI, 2.0 GSI 16V, 2.0 GSI 16V CAT, 2.0 GSI CAT		<b>F8-3060</b>
Mounting, axle beam	1.2, 1.3 i CAT, 1.3 N, 1.3 S, 1.4 i, 1.4 S, 1.5 TD, 1.6 D, 1.6 i, 1.6 i CAT, 1.6 S, 1.7 D, 1.8 E, 1.8 GSI, 1.8 i, 1.8 S, 2.0 GSI, 2.0 GSI 16V, 2.0 GSI 16V CAT, 2.0 GSI CAT	ch.N2500001→	<b>F8-4102</b>
Mounting, axle beam	2.0 GSI 16V		<b>F8-4102</b>
Stabiliser Mounting	1.2, 1.3 i CAT, 1.3 N, 1.3 S, 1.4 i, 1.4 S, 1.5 TD, 1.6 D, 1.6 i, 1.6 i CAT, 1.6 S, 1.7 D, 1.8 E, 1.8 GSI, 1.8 i, 1.8 S, 2.0 GSI, 2.0 GSI 16V, 2.0 GSI 16V CAT, 2.0 GSI CAT		<b>F8-5143</b>
Stabiliser Mounting	1.2, 1.3 i CAT, 1.3 N, 1.3 S, 1.4 i, 1.4 S, 1.5 TD, 1.6 D, 1.6 i, 1.6 i CAT, 1.6 S, 1.7 D, 1.8 E, 1.8 GSI, 1.8 i, 1.8 S, 2.0 GSI, 2.0 GSI 16V, 2.0 GSI 16V CAT, 2.0 GSI CAT		<b>F8-5144</b>
Stabiliser Mounting	1.2	ch.Y2000001, Y5000001→	<b>F8-5230</b>
Mounting, stabilizer coupling rod	1.2, 1.3 i CAT, 1.3 N, 1.3 S, 1.4 i, 1.4 S, 1.5 TD, 1.6 D, 1.6 i, 1.6 i CAT, 1.6 S, 1.7 D, 1.8 E, 1.8 GSI, 1.8 i, 1.8 S, 2.0 GSI, 2.0 GSI 16V, 2.0 GSI 16V CAT, 2.0 GSI CAT		<b>F8-5333</b>
Mounting, alternator	1.2, 1.3 i CAT, 1.3 N, 1.3 S		<b>F8-5366</b>

<b>AK-735003</b>	<b>F7-2055</b>	<b>F8-3059</b>	<b>F8-3060</b>	<b>F8-4102</b>	<b>F8-5143</b>	<b>F8-5144</b>
Ref.Nr.:	Ref.Nr.: 1204892	Ref.Nr.: 344509	Ref.Nr.: 90189050	Ref.Nr.: 90372559	Ref.Nr.: 0350112	Ref.Nr.: 0350113
<b>F8-5230</b>	<b>F8-5333</b>	<b>F8-5366</b>	<b>MK-820820</b>	<b>MK-822300</b>	<b>MK-822300S</b>	<b>MK-822920</b>
Ref.Nr.: 0350138	Ref.Nr.: 2875013	Ref.Nr.: 1204885	Ref.Nr.: 1603179	Ref.Nr.: 90345195	Ref.Nr.: 902828	Ref.Nr.: 811498203

Article Description



Article Nr.

Fitting Position



KADETT E Hatchback (33, 34, 43, 44)			09/1984 → 08/1991		
Mounting, alternator	1.4 i, 1.4 S		<b>F8-5366</b>		
Mounting, alternator	1.6 i, 1.6 i CAT, 1.6 S		<b>F8-5366</b>		
Top Strut Mounting	1.2, 1.3 i CAT, 1.3 N, 1.3 S, 1.4 i, 1.4 S, 1.6 i, 1.6 i CAT, 1.6 S		<b>F8-5589</b>		
Rubber Buffer, suspension	All Models		<b>F8-5611</b>		
Rubber Buffer, suspension	2.0 GSI 16V, 2.0 GSI 16V CAT		<b>F8-5710</b>		H=46
Rubber Buffer, suspension	1.2, 1.3 i CAT, 1.3 N, 1.3 S, 1.4 i, 1.4 S, 1.5 TD, 1.6 D, 1.6 i, 1.6 i CAT, 1.6 S, 1.7 D, 1.8 E, 1.8 GSI, 1.8 i, 1.8 S, 2.0 GSI, 2.0 GSI 16V, 2.0 GSI 16V CAT, 2.0 GSI CAT		<b>F8-7584</b>		H=68
Engine Mounting	1.2, 1.3 i CAT, 1.3 N, 1.3 S, 1.4 i, 1.4 S, 1.6 D, 1.6 i, 1.6 i CAT, 1.6 S, 1.7 D, 1.8 E, 1.8 GSI, 1.8 i, 2.0 GSI 16V		<b>F8-8145</b>		
Control Arm-/Trailing Arm Bush	1.2, 1.3 i CAT, 1.3 N, 1.3 S, 1.4 i, 1.4 S, 1.5 TD, 1.6 D, 1.6 i, 1.6 i CAT, 1.6 S, 1.7 D, 1.8 E, 1.8 GSI, 1.8 i, 1.8 S, 2.0 GSI, 2.0 GSI 16V, 2.0 GSI 16V CAT, 2.0 GSI CAT		<b>G9-591</b>		H=59; d=14.5; D1=39; D2=44
Control Arm-/Trailing Arm Bush	1.2, 1.3 i CAT, 1.3 N, 1.3 S, 1.4 i, 1.4 S, 1.5 TD, 1.6 D, 1.6 i, 1.6 i CAT, 1.6 S, 1.7 D, 1.8 E, 1.8 GSI, 1.8 i, 1.8 S, 2.0 GSI, 2.0 GSI 16V, 2.0 GSI 16V CAT, 2.0 GSI CAT		<b>G9-592</b>		H=54; d=6; d1=6; d2=23
Bellow, steering	All Models	with clamps	<b>LM-10045S</b>		d1=42; d2=52; L [mm]=165
Bellow Set, drive shaft	1.2, 1.3 i CAT, 1.3 N, 1.3 S, 1.4 i, 1.4 S, 1.6 D, 1.6 i, 1.6 i CAT, 1.6 S		<b>M-820820</b>		
Bellow, steering	All Models		<b>M-822300</b>		
C.V. Boot	1.5 TD, 1.6 D, 1.7 D, 1.8 E, 1.8 GSI, 1.8 i, 1.8 S, 2.0 GSI, 2.0 GSI 16V, 2.0 GSI CAT	ch.N1000001, N2000001, N5000001→; ch.→N2733477, N5273484, P8202125	<b>M-822900</b>		
Bellow Set, drive shaft	1.2, 1.3 i CAT, 1.3 N, 1.3 S, 1.4 i, 1.4 S, 1.6 i, 1.6 i CAT, 1.6 S		<b>MK-820820</b>		
Bellow Set, drive shaft	1.4 S, 1.6 D, 1.6 S		<b>MK-820820</b>		
Bellow, steering	1.2, 1.3 i CAT, 1.3 N, 1.3 S, 1.4 i, 1.4 S, 1.5 TD, 1.6 D, 1.6 i, 1.6 i CAT, 1.6 S, 1.7 D, 1.8 E, 1.8 GSI, 1.8 i, 1.8 S, 2.0 GSI, 2.0 GSI 16V, 2.0 GSI 16V CAT, 2.0 GSI CAT		<b>MK-822300</b>		H=165; d1=42; d2=52
Bellow, steering	2.0 GSI 16V		<b>MK-822300</b>		H=165; d1=42; d2=52
Repair Kit, steering gear	1.2, 1.3 i CAT, 1.3 N, 1.3 S, 1.4 i, 1.4 S, 1.5 TD, 1.6 D, 1.6 i, 1.6 i CAT, 1.6 S, 1.7 D, 1.8 E, 1.8 GSI, 1.8 i, 1.8 S, 2.0 GSI, 2.0 GSI 16V, 2.0 GSI 16V CAT, 2.0 GSI CAT		<b>MK-822300S</b>		
Repair Kit, steering gear	2.0 GSI 16V		<b>MK-822300S</b>		
Bellow Set, drive shaft	1.5 TD, 1.6 i, 1.6 i CAT, 1.6 S, 2.0 GSI 16V		<b>MK-822920</b>		
Bellow Set, drive shaft	1.6 D, 1.6 S, 1.7 D, 1.8 E, 1.8 GSI, 1.8 i, 1.8 S, 2.0 GSI, 2.0 GSI 16V, 2.0 GSI 16V CAT, 2.0 GSI CAT		<b>MK-822920</b>		

<b>F8-5366</b>	<b>F8-5589</b>	<b>F8-5611</b>	<b>F8-5710</b>	<b>F8-7584</b>	<b>F8-8145</b>	<b>G9-591</b>
Ref.Nr.: 1204885	Ref.Nr.: 344508	Ref.Nr.: 0436940	Ref.Nr.: 0344402	Ref.Nr.: 0344401	Ref.Nr.: 90189509	Ref.Nr.: 90193117
<b>G9-592</b>	<b>LM-10045S</b>		<b>M-822300</b>	<b>M-822900</b>	<b>MK-820820</b>	<b>MK-822300</b>
Ref.Nr.: 352335	Ref.Nr.: 26024585	Ref.Nr.: 1603146	Ref.Nr.: 90090811	Ref.Nr.: 90421747	Ref.Nr.: 1603179	Ref.Nr.: 90345195
<b>MK-822300S</b>	<b>MK-822920</b>					
Ref.Nr.: 902828	Ref.Nr.: 811498203					

**Article Description****Article Nr.****Fitting Position**

<b>KADETT E Combo (38_, 48_)</b>		<b>01/1986 → 07/1994</b>	
Dust Cover Kit, shock absorber	1.3 N, 1.3 S, 1.4 i, 1.4 S, 1.6, 1.6 D, 1.6 i, 1.7 D		<b>AK-735003</b>
Top Strut Mounting	1.6 D, 1.7 D		<b>F8-3059</b> d1=14; d2=37; D=78; $\tau$ [mm]=132
Mounting, axle beam	1.3 N, 1.3 S, 1.4 i, 1.4 S, 1.6, 1.6 D, 1.6 i, 1.7 D		<b>F8-3060</b> H=75; d=12; D1=49; D2=57
Mounting, axle beam	1.3 N, 1.3 S, 1.4 i, 1.4 S, 1.6, 1.6 D, 1.6 i, 1.7 D		<b>F8-4102</b> H=74; d=12; D1=60; D2=66
Stabiliser Mounting	1.6 i, 1.7 D		<b>F8-5143</b> d=17.5
Mounting, alternator	1.6 i		<b>F8-5366</b>
Top Strut Mounting	1.3 N, 1.3 S, 1.4 i, 1.4 S, 1.6, 1.6 i		<b>F8-5589</b>
Rubber Buffer, suspension	1.3 N, 1.3 S, 1.4 i, 1.4 S, 1.6, 1.6 D, 1.6 i, 1.7 D	<b>ST</b>	<b>F8-7584</b> H=68
Engine Mounting	1.6 i, 1.7 D		<b>F8-8145</b>
Control Arm-/Trailing Arm Bush	1.3 N, 1.3 S, 1.4 i, 1.4 S, 1.6, 1.6 D, 1.6 i, 1.7 D		<b>G9-591</b> H=59; d=14.5; D1=39; D2=44
Control Arm-/Trailing Arm Bush	1.3 N, 1.3 S, 1.4 i, 1.4 S, 1.6, 1.6 D, 1.6 i, 1.7 D		<b>G9-592</b> H=54; d=6; d1=6; d2=23
Bellow, steering	1.3 N, 1.3 S, 1.4 i, 1.4 S, 1.6, 1.6 D, 1.6 i, 1.7 D	with clamps	<b>LM-10045S</b> d1=42; d2=52; L [mm]=165
Bellow Set, drive shaft	1.3 N, 1.3 S, 1.4 i, 1.4 S, 1.6, 1.6 D, 1.6 i		<b>M-820820</b>
Bellow, steering	1.3 N, 1.3 S, 1.4 i, 1.4 S, 1.6, 1.6 D, 1.6 i, 1.7 D		<b>M-822300</b>
Bellow Set, drive shaft	1.3 N, 1.3 S, 1.4 i, 1.4 S, 1.6, 1.6 D, 1.6 i		<b>MK-820820</b>
Bellow, steering	1.3 N, 1.3 S, 1.4 i, 1.4 S, 1.6, 1.6 D, 1.6 i, 1.7 D		<b>MK-822300</b> H=165; d1=42; d2=52
Repair Kit, steering gear	1.3 N, 1.3 S, 1.4 i, 1.4 S, 1.6, 1.6 D, 1.6 i, 1.7 D		<b>MK-822300S</b>
Bellow Set, drive shaft	1.6, 1.6 D, 1.6 i, 1.7 D		<b>MK-822920</b>
<b>KADETT E Box (37_, 47_)</b>		<b>08/1984 → 09/1993</b>	
Dust Cover Kit, shock absorber	1.2, 1.3 N, 1.4 i, 1.6 D, 1.6 i		<b>AK-735003</b>
Mounting, axle beam	All Models		<b>F8-3060</b> H=75; d=12; D1=49; D2=57
Mounting, axle beam	All Models		<b>F8-4102</b> H=74; d=12; D1=60; D2=66
Stabiliser Mounting	1.3 N, 1.4 i, 1.7 D		<b>F8-5143</b> d=17.5
Mounting, alternator	1.3 N		<b>F8-5366</b>
Top Strut Mounting	1.3 N, 1.4 i, 1.6 i		<b>F8-5589</b>
Rubber Buffer, suspension	All Models		<b>F8-5611</b>
Rubber Buffer, suspension	1.3 N, 1.4 i, 1.6 i, 1.7 D	<b>ST</b>	<b>F8-7584</b> H=68
Engine Mounting	1.3 N		<b>F8-8145</b>
Control Arm-/Trailing Arm Bush	All Models		<b>G9-591</b> H=59; d=14.5; D1=39; D2=44
Control Arm-/Trailing Arm Bush	All Models		<b>G9-592</b> H=54; d=6; d1=6; d2=23
Bellow, steering	All Models	with clamps	<b>LM-10045S</b> d1=42; d2=52; L [mm]=165
Bellow Set, drive shaft	1.2, 1.3 N, 1.4 i, 1.6 D, 1.6 i		<b>M-820820</b>

<b>AK-735003</b>	<b>F8-3059</b>	<b>F8-3060</b>	<b>F8-4102</b>	<b>F8-5143</b>	<b>F8-5366</b>	<b>F8-5589</b>
Ref.Nr.:	Ref.Nr.: 344509	Ref.Nr.: 90189050	Ref.Nr.: 90372559	Ref.Nr.: 0350112	Ref.Nr.: 1204885	Ref.Nr.: 344508
<b>F8-5611</b>	<b>F8-7584</b>	<b>F8-8145</b>	<b>G9-591</b>	<b>G9-592</b>	<b>LM-10045S</b>	<b>M-820820</b>
Ref.Nr.: 0436940	Ref.Nr.: 0344401	Ref.Nr.: 90189509	Ref.Nr.: 90193117	Ref.Nr.: 352335	Ref.Nr.: 26024585	Ref.Nr.: 1603146
<b>M-822300</b>	<b>MK-820820</b>	<b>MK-822300</b>	<b>MK-822300S</b>	<b>MK-822920</b>		
Ref.Nr.: 90090811	Ref.Nr.: 1603179	Ref.Nr.: 90345195	Ref.Nr.: 902828	Ref.Nr.: 811498203		

Article Description



Article Nr.

Fitting Position



<b>KADETT E Box (37_, 47_)</b>		<b>08/1984 → 09/1993</b>	
Bellow, steering	All Models	<b>M-822300</b>	⊕ ⊕ ⊕
Bellow Set, drive shaft	1.2, 1.3 N, 1.4 i, 1.6 D, 1.6 i	<b>MK-820820</b>	
Bellow, steering	All Models	<b>MK-822300</b>	H=165; d1=42; d2=52
Repair Kit, steering gear	All Models	<b>MK-822300S</b>	⊕ ⊕ ⊕
Bellow Set, drive shaft	1.6 D, 1.6 i, 1.7 D, 1.8 i	<b>MK-822920</b>	⊕ ⊕ ⊕
<b>MANTA A (58_, 59_)</b>		<b>09/1970 → 08/1975</b>	
Mounting, stabilizer coupling rod	1.9 GT/E	<b>F8-5333</b>	d=8.5; D=30
Mounting, alternator	1.6	Engine627870→	<b>F8-5366</b>
Mounting, alternator	1.6 S	Engine702711→	<b>F8-5366</b>
<b>MANTA B (58_, 59_)</b>		<b>09/1975 → 08/1988</b>	
Mounting, alternator	1.2 S, 1.3 N, 1.3 S, 1.6 N, 1.6 S, 1.8 S, 1.9 E, 1.9 N, 1.9 S, 2.0, 2.0 E, 2.0 S	<b>F7-2055</b>	H=9; d=8; D=26
Stabiliser Mounting	1.2 S	ch.Y2000001, Y5000001→	<b>F8-5230</b> d=18
Mounting, stabilizer coupling rod	1.2 N, 1.2 S, 1.3 N, 1.3 S, 1.6 N, 1.6 S, 1.8 S, 1.9 E, 1.9 N, 1.9 S, 2.0, 2.0 E, 2.0 S, 2.4 400	<b>F8-5333</b>	d=8.5; D=30
Mounting, alternator	1.3 N, 1.3 S	Engine1073534→	<b>F8-5366</b>
Mounting, alternator	1.6 N	Engine627870→	<b>F8-5366</b>
Mounting, alternator	1.6 S	Engine702711→	<b>F8-5366</b>
Mounting, alternator	1.8 S		<b>F8-5366</b>
Mounting, alternator	1.9 N	Engine545150→	<b>F8-5366</b>
Mounting, alternator	2.0	Engine198154→	<b>F8-5366</b>
Mounting, alternator	2.0 E	Engine173310→	<b>F8-5366</b>
Mounting, alternator	2.0 S	Engine667818→	<b>F8-5366</b>
<b>MANTA B CC (53_, 55_)</b>		<b>09/1975 → 08/1988</b>	
Mounting, alternator	1.3 N, 1.3 S, 1.6 N, 1.8 S, 1.9 N, 2.0, 2.0 E, 2.0 S	<b>F7-2055</b>	H=9; d=8; D=26
Mounting, stabilizer coupling rod	1.3 N, 1.3 S, 1.6 N, 1.8 S, 1.9 N, 2.0, 2.0 E, 2.0 S	<b>F8-5333</b>	d=8.5; D=30
Mounting, alternator	1.3 N, 1.3 S	Engine1073534→	<b>F8-5366</b>
Mounting, alternator	1.8 S		<b>F8-5366</b>
Mounting, alternator	2.0	Engine198154→	<b>F8-5366</b>
Mounting, alternator	2.0 E	Engine173310→	<b>F8-5366</b>
Mounting, alternator	2.0 S	Engine667818→	<b>F8-5366</b>
<b>MERIVA</b>		<b>05/2003 → 05/2010</b>	
Alternator Freewheel Clutch	1.3 CDTI	<b>F5-1041</b>	



**Article Description****Article Nr.****Fitting Position****MERIVA** 05/2003 → 05/2010

Alternator Freewheel Clutch	1.3 CDTI		<b>F5-1045</b>		
Alternator Freewheel Clutch	1.7 CDTI		<b>F5-1049</b>		
Control Arm-/Trailing Arm Bush	All Models		<b>F8-5262</b>		
Suspension Kit	1.3 CDTI, 1.4 16V Twinport, 1.4 16V Twinport LPG, 1.6, 1.6 16V, 1.7 CDTI, 1.7 DTI, 1.8	with fastening material	<b>F8-5263</b>		
Top Strut Mounting	1.6, 1.6 16V, 1.7 CDTI, 1.7 DTI	Bearing Type: Soft Version;	<b>F8-5448</b>		
Top Strut Mounting	1.3 CDTI, 1.4 16V Twinport, 1.6, 1.6 16V, 1.6 Turbo, 1.7 CDTI, 1.7 DTI, 1.8		<b>F8-5463</b>		
Rubber Buffer, suspension	1.3 CDTI, 1.4 16V Twinport, 1.6, 1.6 16V, 1.6 Turbo, 1.7 CDTI, 1.7 DTI, 1.8		<b>F8-6517</b>		
Engine Mounting	1.3 CDTI, 1.6, 1.6 16V, 1.7 DTI, 1.8		<b>F8-6753</b>		
Engine Mounting	1.4 16V Twinport	Automated	<b>F8-6753</b>		
Engine Mounting	1.6		<b>F8-6753</b>		
Belt Pulley, crankshaft	1.7 DTI	Number of Ribs: 6	<b>F8-7089</b>		Belt Pulley Ø [mm]=141; Mounting points diam.[mm]=48; W=27.5
Rubber Buffer, suspension	All Models		<b>F8-7698</b>		H=63
Engine Mounting	1.4 16V Twinport, 1.4 16V Twinport LPG	Code: KZ HU;	<b>F8-7793</b>		
Engine Mounting	1.4 16V Twinport, 1.4 16V Twinport LPG	Code: KZ HT;	<b>F8-7794</b>		
Belt Pulley, crankshaft	1.7 CDTI	Z 17 DTR; Number of Ribs: 5; Parameter: 6PK	<b>F8-7872</b>		Belt Pulley Ø [mm]=149; H1=22; H2=32
Mounting, axle beam	1.3 CDTI, 1.4 16V Twinport, 1.4 16V Twinport LPG, 1.6, 1.6 16V, 1.6 Turbo, 1.7 CDTI, 1.7 DTI, 1.8		<b>F8-7913</b>		
Stabiliser Mounting	1.3 CDTI, 1.4 16V Twinport, 1.4 16V Twinport LPG, 1.6, 1.6 16V, 1.6 Turbo, 1.7 CDTI, 1.7 DTI, 1.8		<b>F8-7926</b>		d=21
Repair Kit, suspension strut	1.3 CDTI, 1.4 16V Twinport, 1.4 16V Twinport LPG, 1.6, 1.6 16V, 1.6 Turbo, 1.7 CDTI, 1.7 DTI, 1.8		<b>F8-8085</b>		
Engine Mounting	1.7 CDTI		<b>F8-8158</b>		
Repair Kit, suspension strut	1.3 CDTI, 1.4 16V Twinport, 1.4 16V Twinport LPG, 1.6, 1.6 16V, 1.6 Turbo, 1.7 CDTI, 1.7 DTI, 1.8	Bearing Type: Hard Version;	<b>F8-8214</b>		

**MERIVA B** 06/2010 →

Alternator Freewheel Clutch	1.3 CDTI		<b>F5-1041</b>		
Alternator Freewheel Clutch	1.3 CDTI		<b>F5-1045</b>		
Alternator Freewheel Clutch	1.4	ch.C4000001→	<b>F5-1135</b>		
Alternator Freewheel Clutch	1.4	ch.→B4999999	<b>F5-1141</b>		
Engine Mounting	1.4	Code: KZ JE	<b>F8-6975</b>		
Engine Mounting	1.4, 1.4 LPG	Code: KZ JE;	<b>F8-6975</b>		
Engine Mounting	1.7 CDTI	Code: KZ KA;	<b>F8-6984</b>		
Spring Cap	1.3 CDTI, 1.4, 1.4 LPG, 1.7 CDTI		<b>F8-7422</b>		

<b>F5-1041</b>	<b>F5-1045</b>	<b>F5-1049</b>	<b>F5-1135</b>	<b>F5-1141</b>	<b>F8-5262</b>	<b>F8-5263</b>
Ref.Nr.: 77364723	Ref.Nr.: 77362721	Ref.Nr.: 1204366	Ref.Nr.: 1204184	Ref.Nr.:	Ref.Nr.: 13138151	Ref.Nr.: 352309
<b>F8-5448</b>	<b>F8-5463</b>	<b>F8-6517</b>	<b>F8-6753</b>	<b>F8-6975</b>	<b>F8-6984</b>	<b>F8-7089</b>
Ref.Nr.: 0344523	Ref.Nr.: 0344525	Ref.Nr.: 90468618	Ref.Nr.: 0684238	Ref.Nr.: 24459803	Ref.Nr.: 13159997	Ref.Nr.: 5614444
<b>F8-7422</b>	<b>F8-7662</b>	<b>F8-7698</b>	<b>F8-7793</b>	<b>F8-7794</b>	<b>F8-7872</b>	<b>F8-7913</b>
Ref.Nr.: 344963	Ref.Nr.: 0344956	Ref.Nr.: 24403535	Ref.Nr.: 13125209	Ref.Nr.: 13125208	Ref.Nr.: 614758	Ref.Nr.: 5402638

Article Description



Article Nr.

Fitting Position



<b>MERIVA B</b>			<b>06/2010 →</b>		
Rubber Buffer, suspension	1.3 CDTI, 1.4, 1.7 CDTI		<b>F8-7662</b>		H=40
Rubber Buffer, suspension	1.4 LPG		<b>F8-7662</b>		H=40
Protective Cap/Bellow, shock absorber	1.3 CDTI, 1.4, 1.4 LPG, 1.7 CDTI		<b>F8-7663</b>		H=205
Rubber Buffer, suspension	1.3 CDTI, 1.4, 1.4 LPG, 1.7 CDTI		<b>F8-7699</b>		H=50
Belt Pulley, crankshaft	1.7 CDTI	Number of Ribs: 5; Parameter: 6PK	<b>F8-7872</b>		Belt Pulley Ø [mm]=149; H1=22; H2=32
Control Arm-/Trailing Arm Bush	1.3 CDTI, 1.4, 1.4 LPG, 1.7 CDTI		<b>F8-7946</b>		
Engine Mounting	1.4, 1.4 LPG		<b>F8-8142</b>		
<b>MOKKA</b>			<b>06/2012 →</b>		
Belt Pulley, crankshaft	1.7 CDTI, 1.7 CDTI 4x4	Number of Ribs: 5; Parameter: 6PK	<b>F8-7872</b>		Belt Pulley Ø [mm]=149; H1=22; H2=32
<b>MONZA A (22_)</b>			<b>02/1978 → 08/1986</b>		
Dust Cover Kit, shock absorber	All Models		<b>AK-735005</b>		
Mounting, alternator	2.0 E, 2.2 E, 2.5 E, 2.8, 3.0, 3.0 GSE		<b>F7-2054</b>		H=27; d=8; D1=18; D2=22
Mounting, alternator	2.0 E, 2.2 E, 2.5 E, 2.8, 3.0, 3.0 GSE		<b>F7-2055</b>		H=9; d=8; D=26
Mounting, stabilizer coupling rod	2.5 E, 2.8, 3.0, 3.0 GSE		<b>F8-5333</b>		d=8.5; D=30
Mounting, alternator	2.0 E, 2.5 E		<b>F8-5366</b>		
Mounting, alternator	2.8	Engine104878→	<b>F8-5366</b>		
Mounting, alternator	3.0	Engine9496→	<b>F8-5366</b>		
Mounting, alternator	3.0 GSE	Engine37717→	<b>F8-5366</b>		
Joint, propshaft	2.5 E, 2.8, 3.0, 3.0 GSE		<b>F8-6765</b>		d=50; D=127
<b>MOVANO Combi (J9)</b>			<b>07/1998 → 10/2001</b>		
Alternator Freewheel Clutch	1.9 DTI, 2.2 DTI		<b>F5-1025</b>		
Alternator Freewheel Clutch	3.0 DTI		<b>F5-1035</b>		
Alternator Freewheel Clutch	1.9 DTI		<b>F5-1036</b>		
Alternator Freewheel Clutch	2.2 DTI		<b>F5-1063</b>		
Gear, camshaft	1.9 DTI	Engine Management: Timing Belt;  40	<b>F8-6254</b>		d=13; D=120; W=30
Engine Mounting	1.9 DTI, 2.2 DTI, 2.5 CDTI, 2.5 DTI, 3.0 DTI		<b>F8-6524</b>		
Control Arm-/Trailing Arm Bush	1.9 DTI, 2.2 DTI, 2.5 CDTI, 2.5 D, 2.5 DTI, 2.8 DTI, 3.0 DTI		<b>F8-6673</b>		H=74; d=28; D=55,2
Control Arm-/Trailing Arm Bush	1.9 DTI, 2.2 DTI, 2.5 CDTI, 2.5 D, 2.5 DTI, 2.8 DTI, 3.0 DTI		<b>F8-6674</b>		H=79; d=28; D=55,5
Mounting, leaf spring	1.9 DTI, 2.2 DTI, 2.5 CDTI, 2.5 D, 2.5 DTI, 2.8 DTI, 3.0 DTI		<b>F8-6684</b>		
Mounting, axle beam	1.9 DTI, 2.2 DTI, 2.5 CDTI, 2.5 D, 2.5 DTI, 2.8 DTI, 3.0 DTI		<b>F8-6686</b>		H=80; d=22; D=47

<b>AK-735005</b>	<b>F5-1025</b>	<b>F5-1035</b>	<b>F5-1036</b>	<b>F5-1063</b>	<b>F7-2054</b>	<b>F7-2055</b>
Ref.Nr.:	Ref.Nr.: 23151-00Q0B	Ref.Nr.: 23150-2W200	Ref.Nr.: 23151-00Q0A	Ref.Nr.:	Ref.Nr.: 1204879	Ref.Nr.: 1204892
<b>F8-5333</b>	<b>F8-5366</b>	<b>F8-6254</b>	<b>F8-6524</b>	<b>F8-6673</b>	<b>F8-6674</b>	<b>F8-6684</b>
Ref.Nr.: 2875013	Ref.Nr.: 1204885	Ref.Nr.: 8200125710	Ref.Nr.: 8200027176	Ref.Nr.: 54570-00QAA	Ref.Nr.: 4500095	Ref.Nr.: 55046-00QAB
<b>F8-6686</b>	<b>F8-6687</b>	<b>F8-6765</b>	<b>F8-7662</b>	<b>F8-7663</b>	<b>F8-7699</b>	<b>F8-7872</b>
Ref.Nr.: 5000392657	Ref.Nr.: 4500091	Ref.Nr.: 458367	Ref.Nr.: 0344956	Ref.Nr.: 344435	Ref.Nr.: 13117280	Ref.Nr.: 614758



**Article Description****Article Nr.****Fitting Position**

<b>MOVANO Combi (J9)</b>		<b>07/1998 → 10/2001</b>	
Control Arm-/Trailing Arm Bush	1.9 DTI, 2.2 DTI, 2.5 CDTI, 2.5 D, 2.5 DTI, 2.8 DTI, 3.0 DTI	<b>F8-6687</b>	
Engine Mounting	1.9 DTI, 2.5 DTI	<b>F8-6688</b>	
Belt Pulley, crankshaft	1.9 DTI	<b>F8-7652</b>	
Belt Pulley, crankshaft	1.9 DTI	<b>F8-7652</b>	
Bellow, steering	1.9 DTI, 2.2 DTI, 2.5 CDTI, 2.5 D, 2.5 DTI, 2.8 DTI, 3.0 DTI	<b>LM-10032S</b>	
<b>MOVANO Box (F9)</b>		<b>01/1999 → 10/2001</b>	
Alternator Freewheel Clutch	1.9 DTI, 2.2 DTI	<b>F5-1025</b>	
Alternator Freewheel Clutch	3.0 DTI	<b>F5-1035</b>	
Alternator Freewheel Clutch	1.9 DTI	<b>F5-1036</b>	
Alternator Freewheel Clutch	2.2 DTI	<b>F5-1063</b>	
Gear, camshaft	1.9 DTI	<b>F8-6254</b>	
Engine Mounting	1.9 DTI, 2.2 DTI, 2.5 CDTI, 2.5 DTI, 3.0 DTI	<b>F8-6524</b>	
Control Arm-/Trailing Arm Bush	All Models	<b>F8-6673</b>	
Control Arm-/Trailing Arm Bush	All Models	<b>F8-6674</b>	
Mounting, leaf spring	All Models	<b>F8-6684</b>	
Mounting, axle beam	All Models	<b>F8-6686</b>	
Control Arm-/Trailing Arm Bush	All Models	<b>F8-6687</b>	
Engine Mounting	2.2 DTI, 2.5 DTI	<b>F8-6688</b>	
Belt Pulley, crankshaft	1.9 DTI	<b>F8-7652</b>	
Belt Pulley, crankshaft	1.9 DTI	<b>F8-7652</b>	
Bellow, steering	All Models	<b>LM-10032S</b>	
<b>MOVANO Dumptruck (H9)</b>		<b>01/1999 → 10/2001</b>	
Alternator Freewheel Clutch	2.2 DTI	<b>F5-1025</b>	
Alternator Freewheel Clutch	3.0 DTI	<b>F5-1035</b>	
Alternator Freewheel Clutch	2.2 DTI	<b>F5-1063</b>	
Engine Mounting	2.5 CDTI	<b>F8-6524</b>	
Control Arm-/Trailing Arm Bush	2.2 DTI, 2.5 CDTI, 2.5 D, 2.5 DTI, 2.8 DTI	<b>F8-6673</b>	
Control Arm-/Trailing Arm Bush	2.2 DTI, 2.5 CDTI, 2.5 D, 2.5 DTI, 2.8 DTI	<b>F8-6674</b>	
Mounting, leaf spring	2.2 DTI, 2.5 CDTI, 2.5 D, 2.5 DTI, 2.8 DTI	<b>F8-6684</b>	

<b>F5-1025</b>	<b>F5-1035</b>	<b>F5-1036</b>	<b>F5-1063</b>	<b>F8-6254</b>	<b>F8-6524</b>	<b>F8-6673</b>
Ref.Nr.: 23151-00Q0B	Ref.Nr.: 23150-2W200	Ref.Nr.: 23151-00Q0A	Ref.Nr.:	Ref.Nr.: 8200125710	Ref.Nr.: 8200027176	Ref.Nr.: 54570-00QAA
<b>F8-6674</b>	<b>F8-6684</b>	<b>F8-6686</b>	<b>F8-6687</b>	<b>F8-6688</b>	<b>F8-7652</b>	<b>LM-10032S</b>
Ref.Nr.: 4500095	Ref.Nr.: 55046-00QAB	Ref.Nr.: 5000392657	Ref.Nr.: 4500091	Ref.Nr.: 9110612	Ref.Nr.: 93161258	Ref.Nr.: 7701470361

Article Description

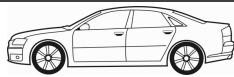

Article Nr.

Fitting Position



<b>MOVANO Dumptruck (H9)</b>			01/1999 → 10/2001	
Mounting, axle beam	2.2 DTI, 2.5 CDTI, 2.5 D, 2.5 DTI, 2.8 DTI		<b>F8-6686</b>	H=80; d=22; D=47
Control Arm-/Trailing Arm Bush	2.2 DTI, 2.5 CDTI, 2.5 D, 2.5 DTI, 2.8 DTI		<b>F8-6687</b>	
Engine Mounting	2.2 DTI, 2.5 DTI		<b>F8-6688</b>	
Bellow, steering	All Models	with clamps	<b>LM-10032S</b>	d1=9.5; d2=42; L [mm]=165
<b>MOVANO Platform/Chassis (U9, E9)</b>			07/1998 → 10/2001	
Alternator Freewheel Clutch	2.2 DTI		<b>F5-1025</b>	
Alternator Freewheel Clutch	3.0 DTI		<b>F5-1035</b>	
Alternator Freewheel Clutch	2.2 DTI		<b>F5-1063</b>	
Engine Mounting	2.2 DTI, 2.5 CDTI, 2.5 DTI, 3.0 DTI		<b>F8-6524</b>	
Control Arm-/Trailing Arm Bush	All Models		<b>F8-6673</b>	H=74; d=28; D=55,2
Control Arm-/Trailing Arm Bush	All Models		<b>F8-6674</b>	H=79; d=28; D=55,5
Mounting, leaf spring	All Models		<b>F8-6684</b>	
Mounting, axle beam	All Models		<b>F8-6686</b>	H=80; d=22; D=47
Control Arm-/Trailing Arm Bush	All Models		<b>F8-6687</b>	
Engine Mounting	2.2 DTI, 2.5 DTI		<b>F8-6688</b>	
Bellow, steering	All Models	with clamps	<b>LM-10032S</b>	d1=9.5; d2=42; L [mm]=165
<b>MOVANO B Bus</b>			12/2010 →	
Alternator Freewheel Clutch	2.3 CDTI		<b>F5-1110</b>	
Alternator Freewheel Clutch	2.3 CDTI		<b>F5-1129</b>	
<b>MOVANO B Box</b>			05/2010 →	
Alternator Freewheel Clutch	2.3 CDTI [RWD], 2.3 CDTI FWD		<b>F5-1110</b>	
Alternator Freewheel Clutch	2.3 CDTI [RWD], 2.3 CDTI FWD		<b>F5-1129</b>	
Belt Pulley, crankshaft	2.3 CDTI [RWD]	M9T 690; Number of Ribs: 6	<b>F8-8039</b>	
Belt Pulley, crankshaft	2.3 CDTI [RWD]	M9T 694; Number of Ribs: 6	<b>F8-8039</b>	
Belt Pulley, crankshaft	2.3 CDTI FWD	M9T 670; Number of Ribs: 6	<b>F8-8039</b>	
Belt Pulley, crankshaft	2.3 CDTI FWD	M9T 678; Number of Ribs: 6	<b>F8-8039</b>	
<b>MOVANO B Platform/Chassis</b>			05/2010 →	
Alternator Freewheel Clutch	2.3 CDTI [RWD], 2.3 CDTI FWD		<b>F5-1110</b>	
Alternator Freewheel Clutch	2.3 CDTI [RWD], 2.3 CDTI FWD		<b>F5-1129</b>	
Belt Pulley, crankshaft	2.3 CDTI [RWD]	M9T 690; Number of Ribs: 6	<b>F8-8039</b>	
Belt Pulley, crankshaft	2.3 CDTI [RWD]	M9T 692; Number of Ribs: 6	<b>F8-8039</b>	
Belt Pulley, crankshaft	2.3 CDTI [RWD]	M9T 694; Number of Ribs: 6	<b>F8-8039</b>	

<b>F5-1025</b>	<b>F5-1035</b>	<b>F5-1063</b>	<b>F5-1110</b>	<b>F5-1129</b>	<b>F8-6524</b>	<b>F8-6673</b>
Ref.Nr.: 23151-00Q0B	Ref.Nr.: 23150-2W200	Ref.Nr.:	Ref.Nr.: 8200489514	Ref.Nr.: 23151-JG71B	Ref.Nr.: 8200027176	Ref.Nr.: 54570-00QAA
<b>F8-6674</b>	<b>F8-6684</b>	<b>F8-6686</b>	<b>F8-6687</b>	<b>F8-6688</b>	<b>F8-8039</b>	<b>LM-10032S</b>
Ref.Nr.: 4500095	Ref.Nr.: 55046-00QAB	Ref.Nr.: 5000392657	Ref.Nr.: 4500091	Ref.Nr.: 9110612	Ref.Nr.: 93168039	Ref.Nr.: 7701470361

**Article Description****Article Nr.****Fitting Position**

<b>MOVANO B Platform/Chassis</b>			<b>05/2010 →</b>		
Belt Pulley, crankshaft	2.3 CDTI FWD	M9T 670; Number of Ribs: 6	<b>F8-8039</b>		
Belt Pulley, crankshaft	2.3 CDTI FWD	M9T 678; Number of Ribs: 6	<b>F8-8039</b>		
<b>OMEGA A (16_, 17_, 19_)</b>			<b>09/1986 → 04/1994</b>		
Dust Cover Kit, shock absorber	1.8, 1.8 N, 1.8 S, 2.0, 2.0 i, 2.3 D, 2.3 TD, 2.3 TD Interc., 2.4 i, 2.6 i, 3.0, 3.0 24V, 3.0 24V Evolution500, 3.6 24V Lotus		<b>AK-735037</b>	⊕ ⊕	
Mounting, alternator	1.8, 1.8 N, 1.8 S, 2.0, 2.0 i, 2.3 D, 2.3 TD, 2.3 TD Interc., 2.4 i, 3.0		<b>F7-2054</b>		H=27; d=8; D1=18; D2=22
Mounting, alternator	3.0	ch.→L1999999	<b>F7-2054</b>		H=27; d=8; D1=18; D2=22
Engine Mounting	1.8, 1.8 N, 1.8 S, 2.0, 2.0 i, 2.4 i		<b>F7-2059</b>	⊕ ⊕	Outer Thread 1 [mm]=M10 x 1,50 RHT M; Outer Thread 2 [mm]=M10 x 1,50 RHT M
Anti-Friction Bearing	1.8, 1.8 N, 1.8 S, 2.0, 2.0 i, 2.3 D, 2.3 TD, 2.3 TD Interc., 2.4 i, 3.0, 3.0 24V, 3.0 24V Evolution500, 3.6 24V Lotus		<b>F8-3024</b>	⊕ ⊕	H=12; d=63; D=86
Anti-Friction Bearing	2.6 i, 3.0 24V		<b>F8-3024</b>	⊕ ⊕	H=12; d=63; D=86
Control Arm-/Trailing Arm Bush	1.8, 1.8 N, 1.8 S, 2.0, 2.0 i, 2.3 D, 2.3 TD, 2.3 TD Interc., 2.4 i, 2.6 i, 3.0, 3.0 24V, 3.0 24V Evolution500, 3.6 24V Lotus		<b>F8-4097</b>	⊕ ⊕	H1=26; H2=69; d=16; D1=27; D2=60
Control Arm-/Trailing Arm Bush	1.8, 1.8 N, 1.8 S, 2.0, 2.0 i, 2.3 D, 2.3 TD, 2.3 TD Interc., 2.4 i, 2.6 i, 3.0, 3.0 24V, 3.0 24V Evolution500, 3.6 24V Lotus		<b>F8-4098</b>	⊕ ⊕ ↓	H=59; d=12; D1=33; D2=46
Control Arm-/Trailing Arm Bush	1.8, 1.8 N, 1.8 S, 2.0, 2.0 i, 2.3 D, 2.3 TD, 2.3 TD Interc., 2.4 i, 2.6 i, 3.0, 3.0 24V, 3.0 24V Evolution500, 3.6 24V Lotus		<b>F8-4099</b>	⊕ ⊕	H=70; d=12; D1=46; D2=49
Top Strut Mounting	1.8, 1.8 N, 1.8 S, 2.0, 2.0 i, 2.3 D, 2.3 TD, 2.3 TD Interc., 2.4 i, 2.6 i, 3.0, 3.0 24V, 3.0 24V Evolution500		<b>F8-4100</b>	⊕ ⊕	H2=55; d=16; D1=96; D2=102
Mounting, axle beam	1.8, 1.8 N, 1.8 S, 2.0, 2.0 i, 2.3 D, 2.3 TD, 2.3 TD Interc., 2.4 i, 2.6 i, 3.0, 3.0 24V, 3.0 24V Evolution500, 3.6 24V Lotus		<b>F8-4101</b>		D1/D2=außen: Ø95/Ø120; H1=53; H2=80; d=18
Mounting, propshaft	1.8, 1.8 N, 1.8 S, 2.0, 2.0 i, 2.3 D, 2.3 TD, 2.3 TD Interc., 2.4 i, 2.6 i, 3.0, 3.0 24V, 3.6 24V Lotus		<b>F8-4106</b>		D1/D2=innen: Ø50/Ø55; H=94; d1=50; d2=55; D=94
Stabiliser Mounting	1.8, 1.8 N, 1.8 S, 2.0, 2.0 i, 2.3 D, 2.3 TD, 2.3 TD Interc., 2.4 i, 2.6 i, 3.0, 3.0 24V, 3.0 24V Evolution500, 3.6 24V Lotus		<b>F8-5331</b>		d=22
Stabiliser Mounting	1.8, 1.8 N, 1.8 S, 2.0, 2.0 i, 2.3 D, 2.3 TD, 2.3 TD Interc., 2.4 i, 2.6 i, 3.0, 3.0 24V		<b>F8-5338</b>		d=13; D=26
Mounting, alternator	2.4 i, 2.6 i, 3.0, 3.0 24V		<b>F8-5366</b>		
Rubber Buffer, suspension	1.8, 1.8 N, 1.8 S, 2.0, 2.0 i, 2.3 D, 2.3 TD, 2.3 TD Interc., 2.4 i, 2.6 i, 3.0, 3.0 24V, 3.0 24V Evolution500, 3.6 24V Lotus		<b>F8-5611</b>	⊕ ⊕ ↑	
Control Arm-/Trailing Arm Bush	3.0 24V, 3.0 24V Evolution500		<b>F8-5722</b>	⊕ ⊕	H=71; d=12; D=43

<b>AK-735037</b>	<b>F7-2054</b>	<b>F7-2059</b>	<b>F8-3024</b>	<b>F8-4097</b>	<b>F8-4098</b>	<b>F8-4099</b>
Ref.Nr.:	Ref.Nr.: 1204879	Ref.Nr.: 24417107	Ref.Nr.: 90121275	Ref.Nr.: 352355	Ref.Nr.: 90279193	Ref.Nr.: 0423313
<b>F8-4100</b>	<b>F8-4101</b>	<b>F8-4106</b>	<b>F8-5331</b>	<b>F8-5338</b>	<b>F8-5366</b>	<b>F8-5611</b>
Ref.Nr.: 344511	Ref.Nr.: 0402935	Ref.Nr.: 0458009	Ref.Nr.: 0350116	Ref.Nr.: 0444325	Ref.Nr.: 1204885	Ref.Nr.: 0436940
<b>F8-5722</b>	<b>F8-5724</b>	<b>F8-8039</b>				
Ref.Nr.: 0423315	Ref.Nr.: 0444153	Ref.Nr.: 93168039				

Article Description

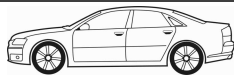

Article Nr.

Fitting Position



<b>OMEGA A (16_, 17_, 19_)</b>		<b>09/1986 → 04/1994</b>	
Stabiliser Mounting	1.8, 1.8 N, 1.8 S, 2.0, 2.0 i, 2.3 D, 2.3 TD, 2.3 TD Interc., 2.4 i, 2.6 i, 3.0, 3.0 24V, 3.0 24V Evolution500, 3.6 24V Lotus	F8-5724	d=14
Rubber Buffer, suspension	1.8, 1.8 N, 1.8 S, 2.0, 2.0 i, 2.3 D, 2.3 TD, 2.3 TD Interc., 2.4 i, 2.6 i, 3.0, 3.0 24V, 3.0 24V Evolution500, 3.6 24V Lotus	F8-5964	H=62; d=29
Top Strut Mounting	3.0	F8-6324	
Idler Arm	1.8, 1.8 N, 1.8 S, 2.0, 2.0 i, 2.4 i	F8-6659	d=18; L=110
Joint, propshaft	2.3 TD, 2.3 TD Interc., 2.4 i, 2.6 i, 3.0, 3.0 24V, 3.0 24V Evolution500	F8-6765	d=50; D=127
Joint, propshaft	1.8, 1.8 N, 1.8 S, 2.0, 2.0 i, 2.3 D	F8-6766	Bolt Hole Circle Ø [mm]=78; d=40; D=109
Engine Mounting	2.3 D, 2.3 TD, 2.3 TD Interc.	Grey F8-6826	
<b>OMEGA A Estate (66_, 67_)</b>		<b>09/1986 → 04/1994</b>	
Dust Cover Kit, shock absorber	1.8, 1.8 N, 1.8 S, 2.0, 2.0 i, 2.3 D, 2.3 TD, 2.3 TD Interc., 2.4 i, 2.6 i, 3.0, 3.0 24V, 3.0 CAT	AK-735037	
Mounting, alternator	1.8, 1.8 N, 1.8 S, 2.0, 2.0 i, 2.3 D, 2.3 TD, 2.3 TD Interc., 2.4 i, 3.0	F7-2054	H=27; d=8; D1=18; D2=22
Mounting, alternator	3.0 CAT	ch.→L1999999 F7-2054	H=27; d=8; D1=18; D2=22
Engine Mounting	1.8, 1.8 N, 1.8 S, 2.0, 2.0 i, 2.4 i	F7-2059	Outer Thread 1 [mm]=M10 x 1,50 RHT M; Outer Thread 2 [mm]=M10 x 1,50 RHT M
Anti-Friction Bearing	1.8, 1.8 N, 1.8 S, 2.0, 2.0 i, 2.3 D, 2.3 TD, 2.3 TD Interc., 2.4 i, 3.0, 3.0 24V, 3.0 CAT	F8-3024	H=12; d=63; D=86
Anti-Friction Bearing	2.6 i	 F8-3024	H=12; d=63; D=86
Control Arm-/Trailing Arm Bush	1.8, 1.8 N, 1.8 S, 2.0, 2.0 i, 2.3 D, 2.3 TD, 2.3 TD Interc., 2.4 i, 2.6 i, 3.0, 3.0 24V, 3.0 CAT	F8-4097	H1=26; H2=69; d=16; D1=27; D2=60
Control Arm-/Trailing Arm Bush	1.8, 1.8 N, 1.8 S, 2.0, 2.0 i, 2.3 D, 2.3 TD, 2.3 TD Interc., 2.4 i, 2.6 i, 3.0, 3.0 24V, 3.0 CAT	F8-4098	H=59; d=12; D1=33; D2=46
Control Arm-/Trailing Arm Bush	1.8, 1.8 N, 1.8 S, 2.0, 2.0 i, 2.3 D, 2.3 TD, 2.3 TD Interc., 2.4 i, 2.6 i, 3.0, 3.0 24V, 3.0 CAT	F8-4099	H=70; d=12; D1=46; D2=49
Top Strut Mounting	1.8, 1.8 N, 1.8 S, 2.0, 2.0 i, 2.3 D, 2.3 TD, 2.3 TD Interc., 2.4 i, 2.6 i, 3.0, 3.0 24V, 3.0 CAT	 F8-4100	H2=55; d=16; D1=96; D2=102
Mounting, axle beam	1.8, 1.8 N, 1.8 S, 2.0, 2.0 i, 2.3 D, 2.3 TD, 2.3 TD Interc., 2.4 i, 2.6 i, 3.0, 3.0 24V, 3.0 CAT	F8-4101	D1/D2=außen: Ø95/Ø120; H1=53; H2=80; d=18
Mounting, propshaft	1.8, 1.8 N, 1.8 S, 2.0, 2.0 i, 2.3 D, 2.3 TD, 2.3 TD Interc., 2.4 i, 2.6 i, 3.0, 3.0 24V, 3.0 CAT	F8-4106	D1/D2=innen: Ø50/Ø55; H=94; d1=50; d2=55; D=94
Stabiliser Mounting	1.8, 1.8 N, 1.8 S, 2.0, 2.0 i, 2.3 D, 2.3 TD, 2.3 TD Interc., 2.4 i, 2.6 i, 3.0, 3.0 24V, 3.0 CAT	F8-5331	d=22
Stabiliser Mounting	1.8, 1.8 N, 1.8 S, 2.0, 2.0 i, 2.3 D, 2.3 TD, 2.3 TD Interc., 2.4 i, 2.6 i, 3.0, 3.0 24V, 3.0 CAT	F8-5338	d=13; D=26
Mounting, alternator	2.4 i, 2.6 i, 3.0, 3.0 CAT	F8-5366	

<b>AK-735037</b>	<b>F7-2054</b>	<b>F7-2059</b>	<b>F8-3024</b>	<b>F8-4097</b>	<b>F8-4098</b>	<b>F8-4099</b>
Ref.Nr.:	Ref.Nr.: 1204879	Ref.Nr.: 24417107	Ref.Nr.: 90121275	Ref.Nr.: 352355	Ref.Nr.: 90279193	Ref.Nr.: 0423313
<b>F8-4100</b>	<b>F8-4101</b>	<b>F8-4106</b>	<b>F8-5331</b>	<b>F8-5338</b>	<b>F8-5366</b>	<b>F8-5724</b>
Ref.Nr.: 344511	Ref.Nr.: 0402935	Ref.Nr.: 0458009	Ref.Nr.: 0350116	Ref.Nr.: 0444325	Ref.Nr.: 1204885	Ref.Nr.: 0444153
<b>F8-5964</b>	<b>F8-6324</b>	<b>F8-6659</b>	<b>F8-6765</b>	<b>F8-6766</b>	<b>F8-6826</b>	
Ref.Nr.: 0344409	Ref.Nr.: 90251358	Ref.Nr.: 920355	Ref.Nr.: 458367	Ref.Nr.: 0458364	Ref.Nr.: 90235055	

**Article Description****Article Nr.****Fitting Position**

<b>OMEGA A Estate (66_, 67_)</b>			<b>09/1986 → 04/1994</b>		
Mounting, alternator	3.0 24V Omega 3000	not for alternator charge current [A]: 80, 90	<b>F8-5366</b>		
Rubber Buffer, suspension	1.8, 1.8 N, 1.8 S, 2.0, 2.0 i, 2.3 D, 2.3 TD, 2.3 TD Interc., 2.4 i, 2.6, 2.6 i, 3.0, 3.0 24V, 3.0 24V Omega 3000, 3.0 CAT		<b>F8-5611</b>		
Control Arm-/Trailing Arm Bush	3.0 24V Omega 3000		<b>F8-5722</b>		H=71; d=12; D=43
Stabiliser Mounting	1.8, 1.8 N, 1.8 S, 2.0, 2.0 i, 2.3 D, 2.3 TD, 2.3 TD Interc., 2.4 i, 2.6 i, 3.0, 3.0 24V, 3.0 24V Omega 3000, 3.0 CAT		<b>F8-5724</b>		d=14
Rubber Buffer, suspension	1.8, 1.8 N, 1.8 S, 2.0, 2.0 i, 2.3 D, 2.3 TD, 2.3 TD Interc., 2.4 i, 2.6 i, 3.0, 3.0 24V, 3.0 24V Omega 3000, 3.0 CAT		<b>F8-5964</b>		H=62; d=29
Top Strut Mounting	3.0, 3.0 CAT		<b>F8-6324</b>		
Idler Arm	1.8, 1.8 N, 1.8 S, 2.0, 2.0 i, 2.4 i		<b>F8-6659</b>		d=18; L=110
Joint, propshaft	2.0, 2.0 i	ch.→1007157	<b>F8-6765</b>		d=50; D=127
Joint, propshaft	2.3 TD, 2.3 TD Interc., 2.4 i, 2.6 i, 3.0, 3.0 24V, 3.0 24V Omega 3000, 3.0 CAT		<b>F8-6765</b>		d=50; D=127
Joint, propshaft	1.8, 1.8 N, 1.8 S, 2.0, 2.0 i, 2.3 D		<b>F8-6766</b>		Bolt Hole Circle Ø [mm]=78; d=40; D=109
Joint, propshaft	2.0	ch.1007158→	<b>F8-6766</b>		Bolt Hole Circle Ø [mm]=78; d=40; D=109
Engine Mounting	2.3 D, 2.3 TD, 2.3 TD Interc.	Grey	<b>F8-6826</b>		
<b>OMEGA B (25_, 26_, 27_)</b>			<b>03/1994 → 07/2003</b>		
Dust Cover Kit, shock absorber	2.0, 2.0 16V, 2.0 DTI 16V, 2.2 16V, 2.2 DTI 16V, 2.5 DTI, 2.5 TD, 2.5 V6, 2.6 V6, 3.0 V6, 3.2 V6		<b>AK-735037</b>		
Engine Mounting	2.0, 2.0 16V, 2.2 16V		<b>F7-2059</b>		Outer Thread 1 [mm]=M10 x 1,50 RHT M; Outer Thread 2 [mm]=M10 x 1,50 RHT M
Anti-Friction Bearing	2.0, 2.0 16V, 2.0 DTI 16V, 2.2 16V, 2.2 DTI 16V, 2.5 DTI, 2.5 TD, 2.5 V6, 2.6 V6, 3.0 V6, 3.2 V6		<b>F8-3024</b>		H=12; d=63; D=86
Control Arm-/Trailing Arm Bush	2.0, 2.0 16V, 2.0 DTI 16V, 2.2 16V, 2.2 DTI 16V, 2.5 DTI, 2.5 TD, 2.5 V6, 2.6 V6, 3.0 V6, 3.2 V6		<b>F8-4099</b>		H=70; d=12; D1=46; D2=49
Top Strut Mounting	2.0, 2.0 16V, 2.0 DTI 16V, 2.2 16V, 2.2 DTI 16V, 2.5 DTI, 2.5 TD, 2.5 V6, 2.6 V6, 3.0 V6, 3.2 V6		<b>F8-4100</b>		H2=55; d=16; D1=96; D2=102
Control Arm-/Trailing Arm Bush	2.0, 2.0 16V, 2.0 DTI 16V, 2.2 16V, 2.2 DTI 16V, 2.5 DTI, 2.5 TD, 2.5 V6, 2.6 V6, 3.0 V6, 3.2 V6		<b>F8-5108</b>		H=56; d=14; D=58
Control Arm-/Trailing Arm Bush	2.0, 2.0 16V, 2.0 DTI 16V, 2.2 16V, 2.2 DTI 16V, 2.5 DTI, 2.5 TD, 2.5 V6, 2.6 V6, 3.0 V6, 3.2 V6		<b>F8-5109</b>		H=46; d=14; D=49
Control Arm-/Trailing Arm Bush	2.0, 2.0 16V, 2.0 DTI 16V, 2.2 16V, 2.5 TD, 2.5 V6, 3.0 V6		<b>F8-5337</b>		d=19; D=100
Stabiliser Mounting	2.0, 2.0 16V, 2.0 DTI 16V, 2.2 16V, 2.5 TD, 2.5 V6, 3.0 V6		<b>F8-5338</b>		d=13; D=26
Belt Pulley, crankshaft	2.0 DTI 16V, 2.2 DTI 16V		<b>F8-5639</b>		

<b>AK-735037</b>	<b>F7-2059</b>	<b>F8-3024</b>	<b>F8-4099</b>	<b>F8-4100</b>	<b>F8-5108</b>	<b>F8-5109</b>
Ref.Nr.:	Ref.Nr.: 24417107	Ref.Nr.: 90121275	Ref.Nr.: 0423313	Ref.Nr.: 344511	Ref.Nr.: 0352302	Ref.Nr.: 352457
<b>F8-5337</b>	<b>F8-5338</b>	<b>F8-5366</b>	<b>F8-5611</b>	<b>F8-5639</b>	<b>F8-5722</b>	<b>F8-5724</b>
Ref.Nr.: 90447156	Ref.Nr.: 0444325	Ref.Nr.: 1204885	Ref.Nr.: 0436940	Ref.Nr.: 0614411	Ref.Nr.: 0423315	Ref.Nr.: 0444153
<b>F8-5964</b>	<b>F8-6324</b>	<b>F8-6659</b>	<b>F8-6765</b>	<b>F8-6766</b>	<b>F8-6826</b>	
Ref.Nr.: 0344409	Ref.Nr.: 90251358	Ref.Nr.: 920355	Ref.Nr.: 458367	Ref.Nr.: 0458364	Ref.Nr.: 90235055	

<b>Article Description</b>			<b>Article Nr.</b>	<b>Fitting Position</b>	
----------------------------	--	--	--------------------	-------------------------	--

**OMEGA B (25\_, 26\_, 27\_) 03/1994 → 07/2003**

Control Arm-/Trailing Arm Bush	2.0, 2.0 16V, 2.0 DTI 16V, 2.2 16V, 2.2 DTI 16V, 2.5 DTI, 2.5 TD, 2.5 V6, 2.6 V6, 3.0 V6, 3.2 V6		<b>F8-5722</b>		H=71; d=12; D=43
Stabiliser Mounting	2.0, 2.0 16V, 2.0 DTI 16V, 2.2 16V, 2.2 DTI 16V, 2.5 DTI, 2.5 TD, 2.5 V6, 2.6 V6, 3.0 V6, 3.2 V6		<b>F8-5724</b>		d=14
Mounting, axle beam	2.0, 2.0 16V, 2.0 DTI 16V, 2.2 16V, 2.2 DTI 16V, 2.5 DTI, 2.5 TD, 2.5 V6, 2.6 V6, 3.0 V6, 3.2 V6		<b>F8-5911</b>		H=59; D=47.5
Rubber Buffer, suspension	2.0, 2.0 16V, 2.0 DTI 16V, 2.2 16V, 2.2 DTI 16V, 2.5 TD, 2.5 V6, 2.6 V6, 3.0 V6, 3.2 V6		<b>F8-5964</b>		H=62; d=29
Stabiliser Mounting	2.0, 2.0 16V, 2.0 DTI 16V, 2.2 16V, 2.2 DTI 16V, 2.5 DTI, 2.5 TD, 2.5 V6, 2.6 V6, 3.0 V6, 3.2 V6		<b>F8-5970</b>		H=29; D1=32; D2=29
Stabiliser Mounting	2.0, 2.0 16V, 2.0 DTI 16V, 2.2 16V, 2.2 DTI 16V, 2.5 DTI, 2.5 TD, 2.5 V6, 2.6 V6, 3.0 V6, 3.2 V6		<b>F8-6091</b>		d=23; L=40
Top Strut Mounting	2.0, 2.0 16V, 2.0 DTI 16V, 2.2 16V, 2.2 DTI 16V, 2.5 DTI, 2.5 TD, 2.5 V6, 2.6 V6, 3.0 V6, 3.2 V6		<b>F8-6324</b>		
Idler Arm	2.0, 2.0 16V, 2.0 DTI 16V, 2.2 16V, 2.2 DTI 16V, 2.5 DTI, 2.5 TD, 2.5 V6, 2.6 V6, 3.0 V6, 3.2 V6		<b>F8-6659</b>		d=18; L=110
Joint, propshaft	2.0 DTI 16V, 2.2 16V, 2.5 TD, 2.5 V6, 3.0 V6		<b>F8-6765</b>		d=50; D=127
Joint, propshaft	2.0, 2.0 16V		<b>F8-6766</b>		Bolt Hole Circle Ø [mm]=78; d=40; D=109
Engine Mounting	2.2 16V	ch.Y1101126→; Grey	<b>F8-6826</b>		
Engine Mounting	2.5 TD	Grey	<b>F8-6826</b>		
Engine Mounting	2.5 DTI	Manufacturer Restriction: Code: HA	<b>F8-6881</b>		
Mounting, propshaft	2.0 16V, 2.5 TD, 2.5 V6, 3.0 V6		<b>F8-7053</b>		d=55
Engine Mounting	2.5 V6, 3.0 V6	ch.R1127219→; ch.→11125192	<b>F8-7850</b>		Outer Thread 1 [mm]=M10 x 1,50 RHT M; Outer Thread 2 [mm]=M10 x 1,50 RHT M
Engine Mounting	2.6 V6, 3.2 V6	ch.11125193→	<b>F8-7850</b>		Outer Thread 1 [mm]=M10 x 1,50 RHT M; Outer Thread 2 [mm]=M10 x 1,50 RHT M
Engine Mounting	2.5 DTI	Paired article nr: F8-6499	<b>F8-7879</b>		

**OMEGA B Estate (21\_, 22\_, 23\_) 03/1994 → 07/2003**

Dust Cover Kit, shock absorber	2.0, 2.0 16V, 2.0 DTI 16V, 2.2 16V, 2.2 DTI 16V, 2.5 DTI, 2.5 TD, 2.5 V6, 2.6 V6, 3.0 V6, 3.2 V6		<b>AK-735037</b>		
Engine Mounting	2.0, 2.0 16V, 2.2 16V		<b>F7-2059</b>		Outer Thread 1 [mm]=M10 x 1,50 RHT M; Outer Thread 2 [mm]=M10 x 1,50 RHT M
Anti-Friction Bearing	2.0, 2.0 16V, 2.0 DTI 16V, 2.2 16V, 2.2 DTI 16V, 2.5 DTI, 2.5 TD, 2.5 V6, 2.6 V6, 3.0 V6, 3.2 V6		<b>F8-3024</b>		H=12; d=63; D=86
Control Arm-/Trailing Arm Bush	2.0, 2.0 16V, 2.0 DTI 16V, 2.2 16V, 2.2 DTI 16V, 2.5 DTI, 2.5 TD, 2.5 V6, 2.6 V6, 3.0 V6, 3.2 V6		<b>F8-4099</b>		H=70; d=12; D1=46; D2=49
Top Strut Mounting	2.0, 2.0 16V, 2.0 DTI 16V, 2.2 16V, 2.2 DTI 16V, 2.5 DTI, 2.5 TD, 2.5 V6, 2.6 V6, 3.0 V6, 3.2 V6		<b>F8-4100</b>		H2=55; d=16; D1=96; D2=102

<b>AK-735037</b>	<b>F7-2059</b>	<b>F8-3024</b>	<b>F8-4099</b>	<b>F8-4100</b>	<b>F8-5108</b>	<b>F8-5722</b>
Ref.Nr.: _____	Ref.Nr.: 24417107	Ref.Nr.: 90121275	Ref.Nr.: 0423313	Ref.Nr.: 344511	Ref.Nr.: 0352302	Ref.Nr.: 0423315
<b>F8-5724</b>	<b>F8-5911</b>	<b>F8-5964</b>	<b>F8-5970</b>	<b>F8-6091</b>	<b>F8-6324</b>	<b>F8-6659</b>
Ref.Nr.: 0444153	Ref.Nr.: 0402649	Ref.Nr.: 0344409	Ref.Nr.: 0444347	Ref.Nr.: 0350147	Ref.Nr.: 90251358	Ref.Nr.: 920355
<b>F8-6765</b>	<b>F8-6766</b>	<b>F8-6826</b>	<b>F8-6881</b>	<b>F8-7053</b>	<b>F8-7850</b>	<b>F8-7879</b>
Ref.Nr.: 458367	Ref.Nr.: 0458364	Ref.Nr.: 90235055	Ref.Nr.: 5684160	Ref.Nr.: 0458014	Ref.Nr.: 5682505	Ref.Nr.: 9266153

**Article Description****Article Nr.****Fitting Position**

<b>OMEGA B Estate (21_, 22_, 23_)</b>			<b>03/1994 → 07/2003</b>	
Control Arm-/Trailing Arm Bush	2.0, 2.0 16V, 2.0 DTI 16V, 2.2 16V, 2.2 DTI 16V, 2.5 DTI, 2.5 TD, 2.5 V6, 2.6 V6, 3.0 V6, 3.2 V6		<b>F8-5108</b>	⊕ ⊕ ⊕ ↓ H=56; d=14; D=58
Control Arm-/Trailing Arm Bush	2.0, 2.0 16V, 2.0 DTI 16V, 2.2 16V, 2.2 DTI 16V, 2.5 DTI, 2.5 TD, 2.5 V6, 2.6 V6, 3.0 V6, 3.2 V6		<b>F8-5109</b>	⊕ ⊕ ⊕ H=46; d=14; D=49
Control Arm-/Trailing Arm Bush	2.0, 2.0 16V, 2.0 DTI 16V, 2.2 16V, 2.5 TD, 2.5 V6, 3.0 V6		<b>F8-5337</b>	⊕ ⊕ ⊕ d=19; D=100
Stabiliser Mounting	2.0, 2.0 16V, 2.0 DTI 16V, 2.2 16V, 2.5 TD, 2.5 V6, 3.0 V6		<b>F8-5338</b>	⊕ ⊕ ⊕ d=13; D=26
Belt Pulley, crankshaft	2.0 DTI 16V, 2.2 DTI 16V		<b>F8-5639</b>	
Control Arm-/Trailing Arm Bush	2.0, 2.0 16V, 2.0 DTI 16V, 2.2 16V, 2.2 DTI 16V, 2.5 DTI, 2.5 TD, 2.5 V6, 2.6 V6, 3.0 V6, 3.2 V6		<b>F8-5722</b>	⊕ ⊕ ⊕ H=71; d=12; D=43
Stabiliser Mounting	2.0, 2.0 16V, 2.0 DTI 16V, 2.2 16V, 2.2 DTI 16V, 2.5 DTI, 2.5 TD, 2.5 V6, 2.6 V6, 3.0 V6, 3.2 V6		<b>F8-5724</b>	⊕ ⊕ ⊕ d=14
Mounting, axle beam	2.0, 2.0 16V, 2.0 DTI 16V, 2.2 16V, 2.2 DTI 16V, 2.5 DTI, 2.5 TD, 2.5 V6, 2.6 V6, 3.0 V6, 3.2 V6		<b>F8-5911</b>	⊕ ⊕ ⊕ H=59; D=47.5
Rubber Buffer, suspension	2.0, 2.0 16V, 2.0 DTI 16V, 2.2 16V, 2.5 TD, 2.5 V6, 3.0 V6		<b>F8-5964</b>	⊕ ⊕ ⊕ H=62; d=29
Stabiliser Mounting	2.0, 2.0 16V, 2.0 DTI 16V, 2.2 16V, 2.2 DTI 16V, 2.5 DTI, 2.5 TD, 2.5 V6, 2.6 V6, 3.0 V6, 3.2 V6		<b>F8-5970</b>	⊕ ⊕ ⊕ H=29; D1=32; D2=29
Stabiliser Mounting	2.0, 2.0 16V, 2.0 DTI 16V, 2.2 16V, 2.2 DTI 16V, 2.5 DTI, 2.5 TD, 2.5 V6, 2.6 V6, 3.0 V6, 3.2 V6		<b>F8-6091</b>	⊕ ⊕ ⊕ d=23; L=40
Top Strut Mounting	2.0, 2.0 16V, 2.0 DTI 16V, 2.2 16V, 2.2 DTI 16V, 2.5 DTI, 2.5 TD, 2.5 V6, 2.6 V6, 3.0 V6, 3.2 V6		<b>F8-6324</b>	
Idler Arm	2.0, 2.0 16V, 2.0 DTI 16V, 2.2 16V, 2.2 DTI 16V, 2.5 DTI, 2.5 TD, 2.5 V6, 2.6 V6, 3.0 V6, 3.2 V6		<b>F8-6659</b>	d=18; L=110
Joint, propshaft	2.0 DTI 16V, 2.2 16V, 2.5 TD, 2.5 V6, 3.0 V6		<b>F8-6765</b>	d=50; D=127
Joint, propshaft	2.0, 2.0 16V		<b>F8-6766</b>	Bolt Hole Circle Ø [mm]=78; d=40; D=109
Engine Mounting	2.2 16V	ch.Y1101126→; Grey	<b>F8-6826</b>	⊕
Engine Mounting	2.5 TD	Grey	<b>F8-6826</b>	⊕ ⊕
Engine Mounting	2.5 DTI	Manufacturer Restriction: Code: HA	<b>F8-6881</b>	⊕
Mounting, propshaft	2.0 16V, 2.5 TD, 2.5 V6, 3.0 V6		<b>F8-7053</b>	d=55
Engine Mounting	2.5 V6, 3.0 V6	ch.R1127219→; ch.→11125192	<b>F8-7850</b>	⊕ ⊕ ⊕ Outer Thread 1 [mm]=M10 x 1,50 RHT M; Outer Thread 2 [mm]=M10 x 1,50 RHT M
Engine Mounting	2.6 V6, 3.2 V6	ch.11125193→	<b>F8-7850</b>	⊕ ⊕ ⊕ Outer Thread 1 [mm]=M10 x 1,50 RHT M; Outer Thread 2 [mm]=M10 x 1,50 RHT M
Engine Mounting	2.5 DTI	Paired article nr: F8-6499	<b>F8-7879</b>	⊕
<b>REKORD E (17_-19_, 11_, 14_, 16_)</b>			<b>08/1977 → 08/1986</b>	
Dust Cover Kit, shock absorber	1.7, 1.8, 1.8 E, 1.8 S, 1.9, 2.0, 2.0 E, 2.0 S, 2.1 D, 2.2 D, 2.2 E, 2.2 TD		<b>AK-735005</b>	⊕ ⊕ ⊕
Mounting, alternator	2.0 S, 2.2 D, 2.2 E, 2.2 TD		<b>F7-2054</b>	H=27; d=8; D1=18; D2=22

<b>AK-735005</b>	<b>F7-2054</b>	<b>F7-2055</b>	<b>F8-5108</b>	<b>F8-5109</b>	<b>F8-5337</b>	<b>F8-5338</b>
Ref.Nr.:	Ref.Nr.: 1204879	Ref.Nr.: 1204892	Ref.Nr.: 0352302	Ref.Nr.: 352457	Ref.Nr.: 90447156	Ref.Nr.: 0444325
<b>F8-5639</b>	<b>F8-5722</b>	<b>F8-5724</b>	<b>F8-5911</b>	<b>F8-5964</b>	<b>F8-5970</b>	<b>F8-6091</b>
Ref.Nr.: 0614411	Ref.Nr.: 0423315	Ref.Nr.: 0444153	Ref.Nr.: 0402649	Ref.Nr.: 0344409	Ref.Nr.: 0444347	Ref.Nr.: 0350147
<b>F8-6324</b>	<b>F8-6659</b>	<b>F8-6765</b>	<b>F8-6766</b>	<b>F8-6826</b>	<b>F8-6881</b>	<b>F8-7053</b>
Ref.Nr.: 90251358	Ref.Nr.: 920355	Ref.Nr.: 458367	Ref.Nr.: 0458364	Ref.Nr.: 90235055	Ref.Nr.: 5684160	Ref.Nr.: 0458014

Article Description



Article Nr.

Fitting Position



<b>REKORD E (17_, 19_, 11_, 14_, 16_)</b>				<b>08/1977 → 08/1986</b>	
Mounting, alternator	1.7, 1.9, 2.0, 2.0 D, 2.0 S, 2.1 D, 2.2 D, 2.2 E, 2.2 TD		<b>F7-2055</b>		H=9; d=8; D=26
Engine Mounting	1.8 E, 2.0 E, 2.0 S		<b>F7-2059</b>		Outer Thread 1 [mm]=M10 x 1,50 RHT M; Outer Thread 2 [mm]=M10 x 1,50 RHT M
Engine Mounting	2.2 E		<b>F7-2059</b>		Outer Thread 1 [mm]=M10 x 1,50 RHT M; Outer Thread 2 [mm]=M10 x 1,50 RHT M
Mounting, stabilizer coupling rod	All Models		<b>F8-5333</b>		d=8.5; D=30
Mounting, alternator	1.7	Engine442103→	<b>F8-5366</b>		
Mounting, alternator	1.8, 1.8 S, 2.2 E		<b>F8-5366</b>		
Mounting, alternator	1.9	Engine545150→	<b>F8-5366</b>		
Mounting, alternator	2.0	Engine198154→	<b>F8-5366</b>		
Mounting, alternator	2.0 S	Engine667818→	<b>F8-5366</b>		
Rubber Buffer, suspension	All Models		<b>F8-5611</b>		
Joint, propshaft	2.2 TD		<b>F8-6765</b>		d=50; D=127
Engine Mounting	2.0 D, 2.1 D, 2.2 D, 2.2 TD	ch.F000001→; Grey	<b>F8-6826</b>		
Engine Mounting	2.0 D, 2.1 D, 2.2 D, 2.2 TD	ch.F1000028→; Grey	<b>F8-6826</b>		
<b>REKORD E Estate (61_, 66_, 67_)</b>				<b>08/1977 → 08/1986</b>	
Dust Cover Kit, shock absorber	All Models		<b>AK-735005</b>		
Mounting, alternator	2.0 S, 2.2 D, 2.2 E, 2.2 TD, 2.3 D		<b>F7-2054</b>		H=27; d=8; D1=18; D2=22
Mounting, alternator	1.7, 1.9, 2.0, 2.0 D, 2.0 S, 2.1 D, 2.2 D, 2.2 E, 2.2 TD, 2.3 D		<b>F7-2055</b>		H=9; d=8; D=26
Engine Mounting	1.8 E, 2.0 E, 2.0 S, 2.2 E		<b>F7-2059</b>		Outer Thread 1 [mm]=M10 x 1,50 RHT M; Outer Thread 2 [mm]=M10 x 1,50 RHT M
Mounting, stabilizer coupling rod	All Models		<b>F8-5333</b>		d=8.5; D=30
Mounting, alternator	1.7	Engine442103→	<b>F8-5366</b>		
Mounting, alternator	1.8, 1.8 S, 2.2 E		<b>F8-5366</b>		
Mounting, alternator	1.9	Engine545150→	<b>F8-5366</b>		
Mounting, alternator	2.0	Engine198154→	<b>F8-5366</b>		
Mounting, alternator	2.0 S	Engine667818→	<b>F8-5366</b>		
Rubber Buffer, suspension	All Models		<b>F8-5611</b>		
Joint, propshaft	2.2 TD		<b>F8-6765</b>		d=50; D=127
Engine Mounting	2.0 D, 2.1 D, 2.2 D, 2.2 TD	ch.F000001→; Grey	<b>F8-6826</b>		
Engine Mounting	2.0 D, 2.1 D, 2.2 D, 2.2 TD	ch.F1000028→; Grey	<b>F8-6826</b>		





**Article Description****Article Nr.****Fitting Position**

<b>SENATOR A (29_)</b>		<b>02/1978 → 08/1987</b>	
Dust Cover Kit, shock absorber	All Models	<b>AK-735005</b>	
Mounting, alternator	2.0 E, 2.2 E, 2.5 E, 2.8, 3.0, 3.0 E	<b>F7-2055</b>	H=9; d=8; D=26
Engine Mounting	2.0 E	<b>F7-2059</b>	Outer Thread 1 [mm]=M10 x 1,50 RHT M; Outer Thread 2 [mm]=M10 x 1,50 RHT M
Engine Mounting	2.2 E	<b>F7-2059</b>	Outer Thread 1 [mm]=M10 x 1,50 RHT M; Outer Thread 2 [mm]=M10 x 1,50 RHT M
Anti-Friction Bearing	2.5 E, 3.0 E	<b>F8-3024</b>	H=12; d=63; D=86
Top Strut Mounting	2.5 E, 3.0 E	<b>F8-4100</b>	H2=55; d=16; D1=96; D2=102
Mounting, stabilizer coupling rod	2.2 E, 2.2 TD, 2.8, 3.0	<b>F8-5333</b>	d=8.5; D=30
Mounting, alternator	2.0 E, 2.5 E	<b>F8-5366</b>	
Mounting, alternator	2.8	Engine104878→	<b>F8-5366</b>
Mounting, alternator	3.0	Engine9496→	<b>F8-5366</b>
Mounting, alternator	3.0 E	Engine37717→	<b>F8-5366</b>
Joint, propshaft	2.2 TD, 2.5 E, 2.8, 3.0, 3.0 E	<b>F8-6765</b>	d=50; D=127
<b>SENATOR B (29_)</b>		<b>09/1987 → 09/1993</b>	
Mounting, alternator	2.5 i, 3.0	<b>F7-2054</b>	H=27; d=8; D1=18; D2=22
Mounting, alternator	3.0, 3.0 i CAT	ch.→L199999	<b>F7-2054</b>
Anti-Friction Bearing	2.5 i, 2.6 i, 3.0, 3.0 24V, 3.0 i CAT	<b>F8-3024</b>	H=12; d=63; D=86
Control Arm-/Trailing Arm Bush	2.5 i, 2.6 i, 3.0, 3.0 24V, 3.0 i CAT	<b>F8-4097</b>	H1=26; H2=69; d=16; D1=27; D2=60
Control Arm-/Trailing Arm Bush	2.5 i, 2.6 i, 3.0, 3.0 24V, 3.0 i CAT	<b>F8-4098</b>	H=59; d=12; D1=33; D2=46
Control Arm-/Trailing Arm Bush	2.5 i, 2.6 i, 3.0, 3.0 24V, 3.0 i CAT	ch.→L1019854, L5155054	<b>F8-4099</b>
Top Strut Mounting	2.5 i, 2.6 i, 3.0, 3.0 24V, 3.0 i CAT	<b>F8-4100</b>	H2=55; d=16; D1=96; D2=102
Mounting, axle beam	2.5 i, 2.6 i, 3.0, 3.0 24V, 3.0 i CAT	<b>F8-4101</b>	D1/D2=außen: Ø95/Ø120; H1=53; H2=80; d=18
Mounting, propshaft	2.5 i, 2.6 i, 3.0, 3.0 24V, 3.0 i CAT	<b>F8-4106</b>	D1/D2=innen: Ø50/Ø55; H=94; d1=50; d2=55; D=94
Stabiliser Mounting	2.5 i, 2.6 i, 3.0, 3.0 24V, 3.0 i CAT	<b>F8-5331</b>	d=22
Stabiliser Mounting	2.5 i, 2.6 i, 3.0, 3.0 24V, 3.0 i CAT	<b>F8-5338</b>	d=13; D=26
Mounting, alternator	2.5 i, 2.6 i, 3.0	<b>F8-5366</b>	
Mounting, alternator	3.0, 3.0 i CAT	ch.→M1000000	<b>F8-5366</b>
Rubber Buffer, suspension	All Models	<b>F8-5611</b>	
Control Arm-/Trailing Arm Bush	All Models	<b>F8-5722</b>	H=71; d=12; D=43

<b>AK-735005</b>	<b>F7-2054</b>	<b>F7-2055</b>	<b>F7-2059</b>	<b>F8-3024</b>	<b>F8-4097</b>	<b>F8-4098</b>
Ref.Nr.:	Ref.Nr.: 1204879	Ref.Nr.: 1204892	Ref.Nr.: 24417107	Ref.Nr.: 90121275	Ref.Nr.: 352355	Ref.Nr.: 90279193
<b>F8-4099</b>	<b>F8-4100</b>	<b>F8-4101</b>	<b>F8-4106</b>	<b>F8-5331</b>	<b>F8-5333</b>	<b>F8-5338</b>
Ref.Nr.: 0423313	Ref.Nr.: 344511	Ref.Nr.: 0402935	Ref.Nr.: 0458009	Ref.Nr.: 0350116	Ref.Nr.: 2875013	Ref.Nr.: 0444325
<b>F8-5366</b>	<b>F8-5611</b>	<b>F8-5722</b>	<b>F8-5724</b>	<b>F8-6765</b>		
Ref.Nr.: 1204885	Ref.Nr.: 0436940	Ref.Nr.: 0423315	Ref.Nr.: 0444153	Ref.Nr.: 458367		

Article Description

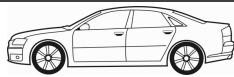

Article Nr.

Fitting Position



<b>SENATOR B (29_)</b>		<b>09/1987 → 09/1993</b>	
Stabiliser Mounting	All Models	F8-5724	
Rubber Buffer, suspension	All Models	F8-5964	
Top Strut Mounting	All Models	F8-6324	
Joint, propshaft	All Models	F8-6765	d=50; D=127
<b>SIGNUM</b>		<b>05/2003 →</b>	
Dust Cover Kit, shock absorber	1.8, 1.9 CDTI, 2.0 DTI, 2.0 Turbo, 2.2 direct, 2.2 DTI, 2.8 V6 Turbo, 3.0 V6 CDTI, 3.2 V6	AK-735251	
Alternator Freewheel Clutch	1.8	F5-1050	
Alternator Freewheel Clutch	2.0 Turbo, 2.2 direct	F5-1079	
Alternator Freewheel Clutch	1.9 CDTI	F5-1102	
Alternator Freewheel Clutch	1.9 CDTI	F5-1123	
Belt Pulley, crankshaft	2.0 DTI, 2.2 DTI	F8-5639	
Control Arm-/Trailing Arm Bush	1.8, 1.9 CDTI, 2.0 DTI, 2.0 Turbo, 2.2 direct, 2.2 DTI, 2.8 V6 Turbo, 3.0 V6 CDTI, 3.2 V6	F8-6447	
Anti-Friction Bearing	1.8, 1.9 CDTI, 2.0 DTI, 2.0 Turbo, 2.2 direct, 2.2 DTI, 2.8, 2.8 V6 Turbo, 3.0 V6 CDTI, 3.2 V6	F8-7172	
Top Strut Mounting	1.8, 1.9 CDTI, 2.0 DTI, 2.0 Turbo, 2.2 direct, 2.2 DTI, 2.8, 2.8 V6 Turbo, 3.0 V6 CDTI, 3.2 V6	F8-7329	
Top Strut Mounting	1.8, 1.9 CDTI, 2.0 DTI, 2.0 Turbo, 2.2 direct, 2.2 DTI, 2.8, 2.8 V6 Turbo, 3.0 V6 CDTI, 3.2 V6	F8-7330	
Control Arm-/Trailing Arm Bush	1.8, 1.9 CDTI, 2.0 DTI, 2.0 Turbo, 2.2 direct, 2.2 DTI, 2.8, 2.8 V6 Turbo, 3.0 V6 CDTI, 3.2 V6	F8-7373	d=12; L=52; L1=32; D=45.5
Protective Cap/Bellow, shock absorber	1.8, 1.9 CDTI, 2.0 DTI, 2.0 Turbo, 2.2 direct, 2.2 DTI, 2.8 V6 Turbo, 3.0 V6 CDTI, 3.2 V6	F8-7663	H=205
Rubber Buffer, suspension	1.8, 1.9 CDTI, 2.0 DTI, 2.0 Turbo, 2.2 direct, 2.2 DTI, 2.8 V6 Turbo, 3.0 V6 CDTI, 3.2 V6	F8-7699	H=50
Stabiliser Mounting	1.8, 1.9 CDTI, 2.0 DTI, 2.0 Turbo, 2.2 direct, 2.2 DTI, 2.8 V6 Turbo, 3.0 V6 CDTI, 3.2 V6	F8-7919	d=17
Stabiliser Mounting	1.8, 1.9 CDTI, 2.0 DTI, 2.0 Turbo, 2.2 direct, 2.2 DTI, 2.8 V6 Turbo, 3.0 V6 CDTI, 3.2 V6	F8-7925	
Mounting, automatic transmission	1.9 CDTI, 2.0 DTI, 2.2 DTI	F8-8170	
<b>SINTRA</b>		<b>11/1996 → 04/1999</b>	
Dust Cover Kit, shock absorber	All Models	AK-735254	
Dust Cover Kit, shock absorber	All Models	AK-735255	
Belt Pulley, crankshaft	2.2 DTI	F8-5639	
Anti-Friction Bearing	All Models	F8-7632	
<b>TIGRA (95_)</b>		<b>07/1994 → 12/2000</b>	
Dust Cover Kit, shock absorber	1.4 16V, 1.6 16V	AK-735003	

<b>AK-735003</b>	<b>AK-735251</b>	<b>AK-735254</b>	<b>AK-735255</b>	<b>F5-1050</b>	<b>F5-1079</b>	<b>F5-1102</b>
Ref.Nr.: _____	Ref.Nr.: 344435	Ref.Nr.: 344645	Ref.Nr.: 434030	Ref.Nr.: 1204412	Ref.Nr.: 1204376	Ref.Nr.: 1204151
<b>F5-1123</b>	<b>F8-3027</b>	<b>F8-5639</b>	<b>F8-5724</b>	<b>F8-5964</b>	<b>F8-6324</b>	<b>F8-6447</b>
Ref.Nr.: 9948513	Ref.Nr.: 90170695	Ref.Nr.: 0614411	Ref.Nr.: 0444153	Ref.Nr.: 0344409	Ref.Nr.: 90251358	Ref.Nr.: 12786412
<b>F8-6765</b>	<b>F8-7172</b>	<b>F8-7329</b>	<b>F8-7330</b>	<b>F8-7373</b>	<b>F8-7632</b>	<b>F8-7663</b>
Ref.Nr.: 458367	Ref.Nr.: 9191181	Ref.Nr.: 344529	Ref.Nr.: 344537	Ref.Nr.: 24469643	Ref.Nr.: 908554	Ref.Nr.: 344435

**Article Description****Article Nr.****Fitting Position**

<b>TIGRA (95_)</b>			<b>07/1994 → 12/2000</b>		
Anti-Friction Bearing	1.4 16V, 1.6 16V		<b>F8-3027</b>		H=27; d=12; D1=95; D2=130
Tie Bar Bush	1.4 16V, 1.6 16V	ch.→V3023597, V4166925, V6066279	<b>F8-5128</b>		H=40; d=14; D=36, 50
Stabiliser Mounting	1.4 16V, 1.6 16V		<b>F8-5228</b>		d=21.5
Mounting, alternator	1.4 16V		<b>F8-5366</b>		
Engine Mounting	1.4 16V, 1.6 16V		<b>F8-5373</b>		
Top Strut Mounting	All Models		<b>F8-5450</b>		
Control Arm-/Trailing Arm Bush	All Models		<b>F8-5552</b>		d=10; L=65; D=42
Rubber Buffer, suspension	1.4 16V, 1.6 16V		<b>F8-5707</b>		H=54
Tie Bar Bush	1.4 16V, 1.6 16V	ch.→3023597, 4166925, 6066279	<b>F8-6037</b>		
Tie Bar Bush	1.4 16V, 1.6 16V	ch.→6066279	<b>F8-6038</b>		
Top Strut Mounting	All Models		<b>F8-6319</b>		
Rubber Buffer, suspension	All Models		<b>F8-6517</b>		
Engine Mounting	1.4 16V, 1.6 16V		<b>F8-8166</b>		
Control Arm-/Trailing Arm Bush	All Models		<b>G9-590</b>		H=52; d1=10; d2=14; D1=38; D2=45
<b>TIGRA TwinTop</b>			<b>06/2004 →</b>		
Alternator Freewheel Clutch	1.3 CDTI		<b>F5-1041</b>		
Alternator Freewheel Clutch	1.3 CDTI		<b>F5-1045</b>		
Control Arm-/Trailing Arm Bush	All Models		<b>F8-5262</b>		
Top Strut Mounting	1.4, 1.8	Bearing Type: Soft Version;	<b>F8-5448</b>		
Rubber Buffer, suspension	All Models		<b>F8-6517</b>		
Engine Mounting	All Models		<b>F8-6753</b>		
Rubber Buffer, suspension	All Models		<b>F8-7698</b>		H=63
Engine Mounting	1.4		<b>F8-7793</b>		
Engine Mounting	1.4		<b>F8-7794</b>		
Repair Kit, suspension strut	All Models		<b>F8-8085</b>		
Engine Mounting	1.4, 1.8		<b>F8-8158</b>		
Engine Mounting	1.4, 1.8		<b>F8-8161</b>		
<b>VECTRA A (86_ , 87_)</b>			<b>09/1988 → 11/1995</b>		
Dust Cover Kit, shock absorber	1.4 S, 1.6, 1.6 i, 1.7 D, 1.7 TD, 1.8 i CAT, 1.8 S, 1.8 S 4x4, 2.0, 2.0 i, 2.0 i 16V, 2.0 i 16V 4x4, 2.0 i 4x4, 2.0 i 4x4 CAT, 2.0 i CAT, 2.0 i Turbo 4x4, 2.5 V6, 2000 16V 4x4, 2000/GT 16V, 2000/GT 16V 4x4 CAT, 2000/GT 16V CAT		<b>AK-735003</b>		
Mounting, alternator	1.8 i CAT, 1.8 S, 2.0 i, 2.0 i 4x4, 2.0 i 4x4 CAT, 2.0 i CAT	ch.→LV299999, M1000000, M5000000	<b>F7-2054</b>		H=27; d=8; D1=18; D2=22



Article Description

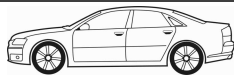

Article Nr.

Fitting Position



VECTRA A (86_, 87_)		09/1988 → 11/1995		
Anti-Friction Bearing	1.4 S, 1.6, 1.6 i, 1.7 D, 1.7 TD, 1.8 i CAT, 1.8 S, 1.8 S 4x4, 2.0, 2.0 i, 2.0 i 16V, 2.0 i 16V 4x4, 2.0 i 4x4, 2.0 i 4x4 CAT, 2.0 i CAT, 2.0 i Turbo 4x4, 2.5 V6, 2000 16V 4x4, 2000/GT 16V, 2000/GT 16V 4x4 CAT, 2000/GT 16V CAT		F8-3026	H=11; d1=16; d2=22; D=41
Mounting, axle beam	1.4 S, 1.6 i, 2.0, 2.0 i Turbo 4x4, 2000/GT 16V		F8-3060	H=75; d=12; D1=49; D2=57
Mounting, axle beam	1.6, 1.6 i, 1.7 D, 1.7 TD, 1.8 i CAT, 1.8 S, 1.8 S 4x4, 2.0 i, 2.0 i 16V, 2.0 i CAT, 2.5 V6, 2000/GT 16V CAT	ch.→N1999999, N5999999, NV299999	F8-3060	H=75; d=12; D1=49; D2=57
Control Arm-/Trailing Arm Bush	1.8 S 4x4, 2.0 i 16V, 2.0 i 16V 4x4, 2.0 i 4x4, 2.0 i 4x4 CAT, 2.0 i Turbo 4x4, 2000 16V 4x4, 2000/GT 16V, 2000/GT 16V 4x4 CAT, 2000/GT 16V CAT		F8-4099	H=70; d=12; D1=46; D2=49
Mounting, axle beam	1.8 S 4x4, 2.0 i, 2.0 i 16V, 2.0 i 16V 4x4, 2.0 i 4x4, 2.0 i 4x4 CAT, 2.0 i CAT, 2.0 i Turbo 4x4, 2.5 V6, 2000 16V 4x4, 2000/GT 16V, 2000/GT 16V 4x4 CAT, 2000/GT 16V CAT		F8-4101	D1/D2=außen: Ø95/Ø120; H1=53; H2=80; d=18
Mounting, axle beam	1.4 S, 1.6 i, 1.8 S 4x4, 2.0, 2.0 i 16V 4x4, 2.0 i 4x4, 2.0 i 4x4 CAT, 2.0 i Turbo 4x4, 2000 16V 4x4, 2000/GT 16V, 2000/GT 16V 4x4 CAT		F8-4102	H=74; d=12; D1=60; D2=66
Mounting, axle beam	1.6, 1.6 i, 1.7 D, 1.7 TD, 1.8 i CAT, 1.8 S, 2.0 i, 2.0 i 16V, 2.0 i CAT, 2.5 V6, 2000/GT 16V CAT	ch.P1000001, P5000001, P7000001→	F8-4102	H=74; d=12; D1=60; D2=66
Stabiliser Mounting	1.4 S, 1.6, 1.6 i, 1.7 D, 1.7 TD, 1.8 i CAT, 1.8 S, 1.8 S 4x4, 2.0 i, 2.0 i 16V, 2.0 i 16V 4x4, 2.0 i 4x4, 2.0 i 4x4 CAT, 2.0 i CAT, 2.0 i Turbo 4x4, 2.5 V6, 2000/GT 16V CAT		F8-5332	d=22
Stabiliser Mounting	1.6 i, 2.0, 2000 16V 4x4, 2000/GT 16V, 2000/GT 16V 4x4 CAT		F8-5332	d=22
Mounting, stabilizer coupling rod	1.4 S, 1.6, 1.6 i, 1.7 D, 1.7 TD, 1.8 i CAT, 1.8 S, 1.8 S 4x4, 2.0, 2.0 i, 2.0 i 16V, 2.0 i 16V 4x4, 2.0 i 4x4, 2.0 i 4x4 CAT, 2.0 i CAT, 2.0 i Turbo 4x4, 2.5 V6, 2000 16V 4x4, 2000/GT 16V, 2000/GT 16V 4x4 CAT, 2000/GT 16V CAT		F8-5333	d=8.5; D=30
Control Arm-/Trailing Arm Bush	1.4 S, 1.6, 1.6 i, 1.7 D, 1.7 TD, 1.8 i CAT, 1.8 S, 1.8 S 4x4, 2.0 i, 2.0 i 16V, 2.0 i 16V 4x4, 2.0 i 4x4, 2.0 i 4x4 CAT, 2.0 i CAT, 2.0 i Turbo 4x4, 2.5 V6, 2000/GT 16V CAT	ch.R1049315, R5112257, R7540516→	F8-5334	d=16; D=60; Thick. [mm]=58
Control Arm-/Trailing Arm Bush	1.6 i, 2.0, 2000 16V 4x4, 2000/GT 16V, 2000/GT 16V 4x4 CAT		F8-5334	d=16; D=60; Thick. [mm]=58
Control Arm-/Trailing Arm Bush	1.4 S, 1.6, 1.6 i, 1.7 D, 1.7 TD, 1.8 i CAT, 1.8 S, 1.8 S 4x4, 2.0, 2.0 i, 2.0 i 16V, 2.0 i 16V 4x4, 2.0 i 4x4, 2.0 i 4x4 CAT, 2.0 i CAT, 2.0 i Turbo 4x4, 2.5 V6, 2000 16V 4x4, 2000/GT 16V, 2000/GT 16V 4x4 CAT, 2000/GT 16V CAT		F8-5336	H=60; d=14; D=64
Stabiliser Mounting	2000/GT 16V CAT	ch.→N1999999, N5999999, NV999999	F8-5338	d=13; D=26
Mounting, alternator	1.4 S, 1.6, 1.6 i	ch.→R5999999, S1000234;	F8-5366	
Engine Mounting	1.4 S, 1.6, 1.6 i		F8-5372	
Engine Mounting	1.8 i CAT, 1.8 S, 1.8 S 4x4, 2.0 i, 2.0 i CAT	ch.→NV999999	F8-5374	

<b>F8-3026</b>	<b>F8-3060</b>	<b>F8-4099</b>	<b>F8-4101</b>	<b>F8-4102</b>	<b>F8-5332</b>	<b>F8-5333</b>
Ref.Nr.: 90425479	Ref.Nr.: 90189050	Ref.Nr.: 0423313	Ref.Nr.: 0402935	Ref.Nr.: 90372559	Ref.Nr.: 0350078	Ref.Nr.: 2875013
<b>F8-5334</b>	<b>F8-5336</b>	<b>F8-5338</b>	<b>F8-5366</b>	<b>F8-5372</b>	<b>F8-5374</b>	
Ref.Nr.: 352356	Ref.Nr.: 90496721	Ref.Nr.: 0444325	Ref.Nr.: 1204885	Ref.Nr.: 90278345	Ref.Nr.: 0684647	

**Article Description****Article Nr.****Fitting Position**

VECTRA A (86_, 87_)			09/1988 → 11/1995	
Engine Mounting	2.5 V6		<b>F8-5374</b>	
Engine Mounting	2000/GT 16V CAT	ch.→L5999999, NV169327	<b>F8-5374</b>	
Engine Mounting	1.7 TD		<b>F8-5391</b>	
Engine Mounting	2.0 i 16V, 2.0 i 16V 4x4		<b>F8-5418</b>	
Engine Mounting	2000/GT 16V CAT	ch.M5000001, N1133945→;	<b>F8-5418</b>	
Engine Mounting	1.8 i CAT, 1.8 S, 1.8 S 4x4, 2.0 i 16V, 2.0 i 16V 4x4, 2.0 i 4x4 CAT, 2.0 i CAT, 2.5 V6		<b>F8-5436</b>	
Engine Mounting	2.0 i Turbo 4x4, 2000/GT 16V CAT		<b>F8-5436</b>	
Engine Mounting	1.8 i CAT, 1.8 S		<b>F8-5438</b>	
Engine Mounting	1.8 S, 1.8 S 4x4, 2.0 i, 2.0 i 4x4		<b>F8-5438</b>	
Engine Mounting	2.0 i Turbo 4x4		<b>F8-5438</b>	
Engine Mounting	2.0 i, 2.0 i 4x4, 2.0 i 4x4 CAT, 2.0 i CAT	ch.→N1999999, N5999999, NV999999;	<b>F8-5438</b>	
Engine Mounting	2000/GT 16V 4x4 CAT, 2000/GT 16V CAT	ch.→L5999999, N1133944;	<b>F8-5438</b>	
Engine Mounting	1.6, 1.6 i		<b>F8-5439</b>	
Engine Mounting	1.7 D		<b>F8-5439</b>	
Engine Mounting	1.4 S	09/1989 →	<b>F8-5444</b>	
Engine Mounting	1.6		<b>F8-5444</b>	
Engine Mounting	1.6 i, 1.7 TD		<b>F8-5444</b>	
Engine Mounting	1.7 D, 1.8 i CAT, 1.8 S, 2.0 i, 2.0 i 16V, 2.0 i CAT, 2.0 i Turbo 4x4, 2000/GT 16V CAT		<b>F8-5445</b>	
Engine Mounting	1.7 TD		<b>F8-5462</b>	
Engine Mounting	1.4 S		<b>F8-5467</b>	
Engine Mounting	1.6 i		<b>F8-5468</b>	
Engine Mounting	1.7 D		<b>F8-5468</b>	
Engine Mounting	1.8 i CAT	ch.→N5299999;	<b>F8-5468</b>	
Engine Mounting	1.8 S, 1.8 S 4x4, 2.0 i, 2.0 i 4x4, 2.0 i 4x4 CAT, 2.0 i CAT	ch.→N1299999, N5299999, NV299999;	<b>F8-5468</b>	
Engine Mounting	2.0 i, 2.0 i 4x4		<b>F8-5468</b>	
Engine Mounting	2000/GT 16V 4x4 CAT	ch.→L5999999, N1133944;	<b>F8-5468</b>	
Engine Mounting	2000/GT 16V CAT	ch.→N1133944, N5999999;	<b>F8-5468</b>	
Top Strut Mounting	1.4 S, 1.6, 1.6 i, 1.7 D, 1.7 TD, 1.8 i CAT, 1.8 S, 1.8 S 4x4, 2.0, 2.0 i, 2.0 i 16V, 2.0 i 16V 4x4, 2.0 i 4x4, 2.0 i 4x4 CAT, 2.0 i CAT, 2.0 i Turbo 4x4, 2.5 V6, 2000 16V 4x4, 2000/GT 16V, 2000/GT 16V 4x4 CAT, 2000/GT 16V CAT		<b>F8-5501</b>	



Article Description

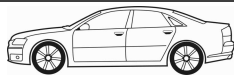

Article Nr.

Fitting Position



VECTRA A (86_, 87_)		09/1988 → 11/1995	
Top Strut Mounting	1.6, 1.6 i, 1.7 D, 1.7 TD, 1.8 i CAT, 1.8 S, 1.8 S 4x4, 2.0, 2.0 i, 2.0 i 16V, 2.0 i 16V 4x4, 2.0 i 4x4, 2.0 i 4x4 CAT, 2.0 i CAT, 2.0 i Turbo 4x4, 2.5 V6, 2000 16V 4x4, 2000/GT 16V, 2000/GT 16V 4x4 CAT, 2000/GT 16V CAT		<b>F8-5501S</b>
Rubber Buffer, suspension	1.4 S, 1.6, 1.6 i, 1.7 D, 1.7 TD, 1.8 i CAT, 1.8 S, 1.8 S 4x4, 2.0 i, 2.0 i 16V, 2.0 i 16V 4x4, 2.0 i 4x4, 2.0 i 4x4 CAT, 2.0 i CAT, 2.0 i Turbo 4x4, 2000/GT 16V CAT		<b>F8-5692</b>
Stabiliser Mounting	1.8 S 4x4, 2.0 i 16V 4x4, 2.0 i 4x4, 2.0 i 4x4 CAT, 2.0 i Turbo 4x4, 2.5 CD 4x4, 2000 16V 4x4, 2000/GT 16V 4x4 CAT, 2000/GT 16V CAT		<b>F8-5724</b>
Control Arm-/Trailing Arm Bush	2000/GT 16V CAT	ch.NV535972, P1001688, P5004911→	<b>F8-5968</b>
Control Arm-/Trailing Arm Bush	2.0 i 16V, 2.0 i 16V 4x4, 2.0 i Turbo 4x4, 2.5 CD 4x4, 2.5 V6, 2000/GT 16V, 2000/GT 16V 4x4 CAT, 2000/GT 16V CAT	ch.NV535972, P1001688, P5004911→; ch.→R1049314, R5112256, R7540515	<b>F8-5969</b>
Sleeve, control arm mounting	1.4 S, 1.6, 1.6 i, 1.7 D, 1.7 TD, 1.8 i CAT, 1.8 S, 1.8 S 4x4, 2.0, 2.0 i, 2.0 i 16V, 2.0 i 16V 4x4, 2.0 i 4x4, 2.0 i 4x4 CAT, 2.0 i CAT, 2.0 i Turbo 4x4, 2.5 CD 4x4, 2.5 V6, 2000 16V 4x4, 2000/GT 16V, 2000/GT 16V 4x4 CAT, 2000/GT 16V CAT		<b>F8-6656</b>
Top Strut Mounting	1.4 S, 1.6, 1.6 i, 1.7 D, 1.7 TD, 1.8 i CAT, 1.8 S, 1.8 S 4x4, 2.0, 2.0 i, 2.0 i 16V, 2.0 i 16V 4x4, 2.0 i 4x4, 2.0 i 4x4 CAT, 2.0 i CAT, 2.0 i Turbo 4x4, 2.5 CD 4x4, 2.5 V6, 2000 16V 4x4, 2000/GT 16V, 2000/GT 16V 4x4 CAT, 2000/GT 16V CAT	Bearing Type: Soft Version;	<b>F8-7973</b>
Control Arm-/Trailing Arm Bush	1.4 S, 1.6, 1.6 i, 1.7 D, 1.8 S, 1.8 S 4x4, 2.0, 2.0 i, 2.0 i 16V, 2.0 i 16V 4x4, 2.0 i 4x4, 2.0 i Turbo 4x4, 2000 16V 4x4, 2000/GT 16V		<b>G9-593</b>
Control Arm-/Trailing Arm Bush	1.6 i, 1.7 D, 1.7 TD, 1.8 i CAT, 2.0 i 4x4 CAT, 2.0 i CAT, 2.5 V6, 2000/GT 16V 4x4 CAT, 2000/GT 16V CAT	ch.→R1049313, R5112256, R7540515	<b>G9-593</b>
Control Arm-/Trailing Arm Bush	1.4 S, 1.6, 1.6 i, 1.7 D, 1.8 S, 1.8 S 4x4, 2.0, 2.0 i, 2.0 i 16V, 2.0 i 16V 4x4, 2.0 i 4x4, 2.0 i Turbo 4x4, 2000 16V 4x4, 2000/GT 16V		<b>G9-594</b>
Control Arm-/Trailing Arm Bush	1.6 i, 1.7 D, 1.7 TD, 1.8 i CAT, 2.0 i 4x4 CAT, 2.0 i CAT, 2.5 V6, 2000/GT 16V 4x4 CAT, 2000/GT 16V CAT	ch.R1049314, R5112257, R7540516→	<b>G9-594</b>
Bellow, steering	All Models	ch.→M1300967, M5396085, NV102027; with clamps;	<b>LM-10045S</b>
Bellow Set, drive shaft	1.4 S, 1.6, 1.6 i		<b>M-820820</b>
Bellow, steering	1.4 S, 1.6, 1.6 i, 1.7 D, 1.7 TD, 1.8 i CAT, 1.8 S, 1.8 S 4x4, 2.0, 2.0 i, 2.0 i 16V, 2.0 i 16V 4x4, 2.0 i 4x4, 2.0 i 4x4 CAT, 2.0 i CAT, 2.0 i Turbo 4x4, 2.5 V6, 2000 16V 4x4, 2000/GT 16V, 2000/GT 16V CAT		<b>M-822300</b>
Bellow, steering	1.6, 1.6 i, 2.5 CD 4x4, 2000/GT 16V 4x4 CAT	ch.→M1300967, M5396085, NV102027;	<b>M-822300</b>

<b>F8-5501S</b>	<b>F8-5692</b>	<b>F8-5724</b>	<b>F8-5968</b>	<b>F8-5969</b>	<b>F8-6656</b>	<b>F8-7973</b>
Ref.Nr.: 90289421	Ref.Nr.: 0344411	Ref.Nr.: 0444153	Ref.Nr.: 352351	Ref.Nr.: 352352	Ref.Nr.: 4246062	Ref.Nr.: 344514
<b>G9-593</b>	<b>G9-594</b>	<b>LM-10045S</b>	<b>M-820820</b>	<b>M-822300</b>	<b>M-822900</b>	
Ref.Nr.: 90288232	Ref.Nr.: 90268463	Ref.Nr.: 26024585	Ref.Nr.: 1603146	Ref.Nr.: 90090811	Ref.Nr.: 90421747	

**Article Description****Article Nr.****Fitting Position**

<b>VECTRA A (86_, 87_)</b>		<b>09/1988 → 11/1995</b>	
C.V. Boot	1.7 D, 1.8 i CAT, 1.8 S, 1.8 S 4x4, 2.0 i, 2.0 i 16V, 2.0 i 16V 4x4, 2.0 i 4x4, 2.0 i 4x4 CAT, 2.0 i CAT, 2.0 i Turbo 4x4, 2000/GT 16V CAT	ch.N1000001, N2000001, N5000001→; ch.→N2733477, N5273484, P8202125	<b>M-822900</b>
Bellow Set, drive shaft	1.4 S, 1.6, 1.6 i		<b>MK-820820</b>
Bellow Set, drive shaft	1.6 i	ch.→P5271948	<b>MK-820820</b>
Bellow, steering	1.4 S, 1.6 i, 2.0, 2.0 i Turbo 4x4, 2000 16V 4x4, 2000/GT 16V, 2000/GT 16V 4x4 CAT		<b>MK-822300</b> H=165; d1=42; d2=52
Bellow, steering	1.6, 1.6 i, 1.7 D, 1.7 TD, 1.8 i CAT, 1.8 S, 1.8 S 4x4, 2.0 i, 2.0 i 16V, 2.0 i 16V 4x4, 2.0 i 4x4, 2.0 i 4x4 CAT, 2.0 i CAT, 2.5 V6, 2000/GT 16V CAT	ch.→M1300367, M5396085, NV102027;	<b>MK-822300</b> H=165; d1=42; d2=52
Repair Kit, steering gear	1.4 S, 1.6 i, 2.0, 2.0 i Turbo 4x4, 2000 16V 4x4, 2000/GT 16V, 2000/GT 16V 4x4 CAT		<b>MK-822300S</b>
Repair Kit, steering gear	1.6, 1.6 i, 1.7 D, 1.7 TD, 1.8 i CAT, 1.8 S, 1.8 S 4x4, 2.0 i, 2.0 i 16V, 2.0 i 16V 4x4, 2.0 i 4x4, 2.0 i 4x4 CAT, 2.0 i CAT, 2.5 V6, 2000/GT 16V CAT	ch.→M1300367, M5396085, NV102027;	<b>MK-822300S</b>
Bellow Set, drive shaft	1.7 D, 1.8 i CAT, 1.8 S, 1.8 S 4x4, 2.0 i, 2.0 i 16V, 2.0 i 16V 4x4, 2.0 i 4x4, 2.0 i 4x4 CAT, 2.0 i CAT	ch.→R1999999, R5299999, R7699999	<b>MK-822920</b>
Bellow Set, drive shaft	1.7 TD, 2.0, 2.0 i Turbo 4x4, 2000 16V 4x4, 2000/GT 16V, 2000/GT 16V 4x4 CAT, 2000/GT 16V CAT		<b>MK-822920</b>
<b>VECTRA A Hatchback (88_, 89_)</b>		<b>04/1988 → 11/1995</b>	
Dust Cover Kit, shock absorber	1.6 i, 1.6 i CAT, 1.6 S, 1.7 D, 1.7 TD, 1.8 i, 1.8 i CAT, 1.8 S, 2.0, 2.0 i, 2.0 i 16V, 2.0 i 16V CAT, 2.0 i CAT, 2.0 i GT, 2.5 V6		<b>AK-735003</b>
Mounting, alternator	1.8 i, 1.8 i CAT, 1.8 S, 2.0 i, 2.0 i CAT	ch.→LV299999, M1000000, M5000000	<b>F7-2054</b> H=27; d=8; D1=18; D2=22
Anti-Friction Bearing	1.4 S, 1.6 i, 1.6 i CAT, 1.6 S, 1.7 D, 1.7 TD, 1.8 i, 1.8 i CAT, 1.8 S, 2.0, 2.0 i, 2.0 i 16V, 2.0 i 16V CAT, 2.0 i CAT, 2.0 i GT, 2.5 V6		<b>F8-3026</b> H=11; d1=16; d2=22; D=41
Mounting, axle beam	1.4 S, 1.6 i, 2.0, 2.0 i 16V, 2.0 i GT		<b>F8-3060</b> H=75; d=12; D1=49; D2=57
Mounting, axle beam	1.6 i, 1.6 i CAT, 1.6 S, 1.7 D, 1.7 TD, 1.8 i, 1.8 i CAT, 1.8 S, 2.0 i, 2.0 i 16V, 2.0 i 16V CAT, 2.0 i CAT, 2.5 V6	ch.→N1999999, N5999999, NV299999	<b>F8-3060</b> H=75; d=12; D1=49; D2=57
Control Arm-/Trailing Arm Bush	2.0 i 16V, 2.0 i 16V CAT		<b>F8-4099</b> H=70; d=12; D1=46; D2=49
Mounting, axle beam	2.0 i, 2.0 i 16V, 2.0 i 16V CAT, 2.0 i CAT, 2.0 i GT, 2.5 V6		<b>F8-4101</b> D1/D2=außen: Ø95/Ø120; H1=53; H2=80; d=18
Mounting, axle beam	1.4 S, 1.6 i, 2.0, 2.0 i 16V, 2.0 i GT		<b>F8-4102</b> H=74; d=12; D1=60; D2=66
Mounting, axle beam	1.6 i, 1.6 i CAT, 1.6 S, 1.7 D, 1.7 TD, 1.8 i, 1.8 i CAT, 1.8 S, 2.0 i, 2.0 i 16V, 2.0 i 16V CAT, 2.0 i CAT, 2.5 V6	ch.P1000001, P5000001, P7000001→	<b>F8-4102</b> H=74; d=12; D1=60; D2=66
Stabiliser Mounting	1.4 S, 1.6 i, 1.6 i CAT, 1.6 S, 1.7 D, 1.7 TD, 1.8 i, 1.8 i CAT, 1.8 S, 2.0 i, 2.0 i 16V, 2.0 i 16V CAT, 2.0 i CAT, 2.5 V6		<b>F8-5332</b> d=22
Stabiliser Mounting	1.6 i, 2.0, 2.0 i 16V, 2.0 i GT		<b>F8-5332</b> d=22
Mounting, stabilizer coupling rod	1.4 S, 1.6 i, 1.6 i CAT, 1.6 S, 1.7 D, 1.7 TD, 1.8 i, 1.8 i CAT, 1.8 S, 2.0, 2.0 i, 2.0 i 16V, 2.0 i 16V CAT, 2.0 i CAT, 2.0 i GT, 2.5 V6		<b>F8-5333</b> d=8.5; D=30

<b>AK-735003</b>	<b>F7-2054</b>	<b>F8-3026</b>	<b>F8-3060</b>	<b>F8-4099</b>	<b>F8-4101</b>	<b>F8-4102</b>
Ref.Nr.:	Ref.Nr.: 1204879	Ref.Nr.: 90425479	Ref.Nr.: 90189050	Ref.Nr.: 0423313	Ref.Nr.: 0402935	Ref.Nr.: 90372559
<b>F8-5332</b>	<b>F8-5333</b>	<b>F8-5334</b>	<b>M-822900</b>	<b>MK-820820</b>	<b>MK-822300</b>	<b>MK-822300S</b>
Ref.Nr.: 0350078	Ref.Nr.: 2875013	Ref.Nr.: 352356	Ref.Nr.: 90421747	Ref.Nr.: 1603179	Ref.Nr.: 90345195	Ref.Nr.: 902828
<b>MK-822920</b>						
Ref.Nr.: 811498203						

Article Description



Article Nr.

Fitting Position



<b>VECTRA A Hatchback (88_, 89_)</b>			<b>04/1988 → 11/1995</b>		
Control Arm-/Trailing Arm Bush	1.4 S, 1.6 i, 1.6 i CAT, 1.6 S, 1.7 D, 1.7 TD, 1.8 i, 1.8 i CAT, 1.8 S, 2.0 i, 2.0 i 16V, 2.0 i 16V CAT, 2.0 i CAT, 2.5 V6	ch.R1049315, R5112257, R7540516→	<b>F8-5334</b>		d=16; D=60; Thick. [mm]=58
Control Arm-/Trailing Arm Bush	1.6 i, 2.0, 2.0 i 16V, 2.0 i GT		<b>F8-5334</b>		d=16; D=60; Thick. [mm]=58
Control Arm-/Trailing Arm Bush	1.4 S, 1.6 i, 1.6 i CAT, 1.6 S, 1.7 D, 1.7 TD, 1.8 i, 1.8 i CAT, 1.8 S, 2.0, 2.0 i, 2.0 i 16V, 2.0 i 16V CAT, 2.0 i CAT, 2.0 i GT, 2.5 V6		<b>F8-5336</b>		H=60; d=14; D=64
Stabiliser Mounting	2.0 i 16V CAT	ch.→N1999999, N5999999, NV999999	<b>F8-5338</b>		d=13; D=26
Mounting, alternator	1.4 S, 1.6 i, 1.6 i CAT, 1.6 S	ch.→R5999999, S1000234;	<b>F8-5366</b>		
Engine Mounting	1.4 S, 1.6 i, 1.6 i CAT, 1.6 S		<b>F8-5372</b>		
Engine Mounting	1.8 i, 1.8 i CAT, 1.8 S, 2.0 i, 2.0 i CAT, 2.0 i GT	ch.→NV999999	<b>F8-5374</b>		
Engine Mounting	2.0 i 16V CAT	ch.→L5999999, NV169327	<b>F8-5374</b>		
Engine Mounting	2.5 V6		<b>F8-5374</b>		
Engine Mounting	1.7 TD		<b>F8-5391</b>		
Engine Mounting	2.0 i 16V CAT		<b>F8-5418</b>		
Engine Mounting	1.6 i CAT, 2.0 i 16V CAT		<b>F8-5436</b>		
Engine Mounting	1.8 i, 1.8 i CAT, 1.8 S, 2.0 i 16V, 2.0 i CAT, 2.5 V6		<b>F8-5436</b>		
Engine Mounting	1.8 i CAT, 1.8 S		<b>F8-5438</b>		
Engine Mounting	1.8 i, 2.0 i GT		<b>F8-5438</b>		
Engine Mounting	2.0 i 16V CAT	ch.→L5999999, N1133944;	<b>F8-5438</b>		
Engine Mounting	2.0 i, 2.0 i CAT	ch.→N1999999, N5999999, NV999999;	<b>F8-5438</b>		
Engine Mounting	1.6 i, 1.6 i CAT, 1.6 S		<b>F8-5439</b>		
Engine Mounting	1.7 D		<b>F8-5439</b>		
Engine Mounting	1.4 S	09/1989 →	<b>F8-5444</b>		
Engine Mounting	1.6 i, 1.6 i CAT, 1.7 TD		<b>F8-5444</b>		
Engine Mounting	1.6 S		<b>F8-5444</b>		
Engine Mounting	1.7 D, 1.8 i, 1.8 i CAT, 1.8 S, 2.0 i, 2.0 i 16V, 2.0 i 16V CAT, 2.0 i CAT, 2.0 i GT		<b>F8-5445</b>		
Engine Mounting	1.7 TD		<b>F8-5462</b>		
Engine Mounting	1.4 S		<b>F8-5467</b>		
Engine Mounting	1.6 i CAT		<b>F8-5468</b>		
Engine Mounting	1.7 D		<b>F8-5468</b>		
Engine Mounting	1.8 i, 1.8 i CAT, 1.8 S, 2.0 i, 2.0 i CAT	ch.→N1299999, N5299999, NV299999;	<b>F8-5468</b>		
Engine Mounting	2.0 i 16V CAT	ch.→N1133944, N5999999;	<b>F8-5468</b>		
Engine Mounting	2.0 i GT		<b>F8-5468</b>		

<b>F8-5334</b>	<b>F8-5336</b>	<b>F8-5338</b>	<b>F8-5366</b>	<b>F8-5372</b>	<b>F8-5374</b>	<b>F8-5391</b>
Ref.Nr.: 352356	Ref.Nr.: 90496721	Ref.Nr.: 0444325	Ref.Nr.: 1204885	Ref.Nr.: 90278345	Ref.Nr.: 0684647	Ref.Nr.: 684643
<b>F8-5418</b>	<b>F8-5436</b>	<b>F8-5438</b>	<b>F8-5439</b>	<b>F8-5444</b>	<b>F8-5445</b>	<b>F8-5462</b>
Ref.Nr.: 684646	Ref.Nr.: 0684641	Ref.Nr.: 684291	Ref.Nr.: 684289	Ref.Nr.: 90473852	Ref.Nr.: 0682504	Ref.Nr.: 684644
<b>F8-5467</b>	<b>F8-5468</b>	<b>F8-5501</b>				
Ref.Nr.: 0684285	Ref.Nr.: 0684283	Ref.Nr.: 90268464				



**Article Description****Article Nr.****Fitting Position**

<b>VECTRA A Hatchback (88_ , 89_)</b>		<b>04/1988 → 11/1995</b>	
Top Strut Mounting	1.4 S, 1.6 i, 1.6 i CAT, 1.6 S, 1.7 D, 1.7 TD, 1.8 i, 1.8 i CAT, 1.8 S, 2.0, 2.0 i, 2.0 i 16V, 2.0 i 16V CAT, 2.0 i CAT, 2.0 i GT, 2.5 V6		F8-5501
Top Strut Mounting	1.4 S, 1.6 i, 1.6 i CAT, 1.6 S, 1.7 D, 1.7 TD, 1.8 i, 1.8 i CAT, 1.8 S, 2.0, 2.0 i, 2.0 i 16V, 2.0 i 16V CAT, 2.0 i CAT, 2.0 i GT, 2.5 V6		F8-5501S
Rubber Buffer, suspension	1.4 S, 1.6, 1.6 i, 1.6 i CAT, 1.6 S, 1.7 D, 1.7 TD, 1.8 i, 1.8 i CAT, 1.8 S, 2.0 i, 2.0 i 16V, 2.0 i 16V CAT, 2.0 i CAT, 2.0 i GT		F8-5692
Stabiliser Mounting	2.0 i 16V CAT		F8-5724
Control Arm-/Trailing Arm Bush	2.0 i 16V CAT	ch.NV535972, P1001688, P5004911→	F8-5968
Control Arm-/Trailing Arm Bush	2.0 i 16V, 2.0 i 16V CAT, 2.5 V6	ch.NV535972, P1001688, P5004911→; ch.→R1049314, R5112256, R7540515	F8-5969
Sleeve, control arm mounting	All Models		F8-6656
Top Strut Mounting	1.4 S, 1.6 i, 1.6 i CAT, 1.6 S, 1.7 D, 1.7 TD, 1.8 i, 1.8 i CAT, 1.8 S, 2.0, 2.0 i, 2.0 i 16V, 2.0 i 16V CAT, 2.0 i CAT, 2.0 i GT, 2.5 V6	Bearing Type: Soft Version;	F8-7973
Control Arm-/Trailing Arm Bush	1.4 S, 1.6 i, 1.6 S, 1.7 D, 1.8 i, 1.8 S, 2.0, 2.0 i, 2.0 i 16V		G9-593
Control Arm-/Trailing Arm Bush	1.6 i, 1.6 i CAT, 1.7 D, 1.7 TD, 1.8 i CAT, 2.0 i 16V CAT, 2.0 i CAT, 2.0 i GT, 2.5 V6	ch.→R1049313, R5112256, R7540515	G9-593
Control Arm-/Trailing Arm Bush	1.4 S, 1.6 i, 1.6 S, 1.7 D, 1.8 i, 1.8 S, 2.0, 2.0 i, 2.0 i 16V		G9-594
Control Arm-/Trailing Arm Bush	1.6 i, 1.6 i CAT, 1.7 D, 1.7 TD, 1.8 i CAT, 2.0 i 16V CAT, 2.0 i CAT, 2.0 i GT, 2.5 V6	ch.R1049314, R5112257, R7540516→	G9-594
Bellow, steering	All Models	ch.→M1300967, M5396085, NV102027; with clamps;	LM-10045S
Bellow Set, drive shaft	1.4 S, 1.6 i, 1.6 i CAT, 1.6 S		M-820820
Bellow, steering	1.4 S, 1.6 i, 1.6 i CAT, 1.6 S, 1.7 D, 1.7 TD, 1.8 i, 1.8 i CAT, 1.8 S, 2.0, 2.0 i, 2.0 i 16V, 2.0 i 16V CAT, 2.0 i CAT, 2.0 i GT, 2.5 V6		M-822300
Bellow, steering	1.6, 1.6 i	ch.→M1300967, M5396085, NV102027;	M-822300
C.V. Boot	1.6 i CAT, 1.7 D, 1.8 i, 1.8 i CAT, 1.8 S, 2.0 i, 2.0 i 16V, 2.0 i 16V CAT, 2.0 i CAT, 2.0 i GT	ch.N1000001, N2000001, N5000001→; ch.→N2733477, N5273484, P8202125	M-822900
Bellow Set, drive shaft	1.4 S, 1.6 i, 1.6 S		MK-820820
Bellow Set, drive shaft	1.6 i CAT	ch.→P1175249	MK-820820
Bellow, steering	1.4 S, 1.6 i, 2.0, 2.0 i 16V, 2.0 i GT		MK-822300
Bellow, steering	1.6 i, 1.6 i CAT, 1.6 S, 1.7 D, 1.7 TD, 1.8 i, 1.8 i CAT, 1.8 S, 2.0 i, 2.0 i 16V, 2.0 i 16V CAT, 2.0 i CAT, 2.5 V6	ch.→M1300367, M5396085, NV102027;	MK-822300
Repair Kit, steering gear	1.4 S, 1.6 i, 2.0, 2.0 i 16V, 2.0 i GT		MK-822300S

<b>F8-5501</b>	<b>F8-5501S</b>	<b>F8-5692</b>	<b>F8-5724</b>	<b>F8-5968</b>	<b>F8-5969</b>	<b>F8-6656</b>
Ref.Nr.: 90268464	Ref.Nr.: 90289421	Ref.Nr.: 0344411	Ref.Nr.: 0444153	Ref.Nr.: 352351	Ref.Nr.: 352352	Ref.Nr.: 4246062
<b>F8-7973</b>	<b>G9-593</b>	<b>G9-594</b>	<b>LM-10045S</b>	<b>M-820820</b>	<b>M-822300</b>	<b>M-822900</b>
Ref.Nr.: 344514	Ref.Nr.: 90288232	Ref.Nr.: 90268463	Ref.Nr.: 26024585	Ref.Nr.: 1603146	Ref.Nr.: 90090811	Ref.Nr.: 90421747
<b>MK-820820</b>	<b>MK-822300</b>	<b>MK-822300S</b>				
Ref.Nr.: 1603179	Ref.Nr.: 90345195	Ref.Nr.: 902828				

Article Description



Article Nr.

Fitting Position



<b>VECTRA A Hatchback (88_ , 89_)</b>		<b>04/1988 → 11/1995</b>	
Repair Kit, steering gear	1.6 i, 1.6 i CAT, 1.6 S, 1.7 D, 1.7 TD, 1.8 i, 1.8 i CAT, 1.8 S, 2.0 i, 2.0 i 16V, 2.0 i 16V CAT, 2.0 i CAT, 2.5 V6	ch.→M1300367, M5396085, NV102027;	<b>MK-822300S</b>
Bellow Set, drive shaft	1.6 i CAT, 1.7 D, 1.8 i, 1.8 i CAT, 1.8 S, 2.0 i, 2.0 i 16V, 2.0 i 16V CAT, 2.0 i CAT	ch.→R1999999, R5299999, R7699999	<b>MK-822920</b>
Bellow Set, drive shaft	1.7 TD, 2.0, 2.0 i 16V, 2.0 i GT		<b>MK-822920</b>
<b>VECTRA B (36_)</b>		<b>09/1995 → 04/2002</b>	
Rubber Buffer, suspension	1.6 i, 1.6 i 16V, 1.7 TD, 1.8 i 16V, 2.0 DI 16V, 2.0 DTI 16V, 2.0 i, 2.0 i 16V, 2.2 DTI 16V, 2.2 i 16V, 2.5 i V6, 2.6 i V6		<b>AK-735038</b>
Dust Cover Kit, shock absorber	1.6 GL, 1.6 i, 1.6 i 16V, 1.7 TD, 1.8 i 16V, 2.0 DI 16V, 2.0 DTI 16V, 2.0 i, 2.0 i 16V, 2.2 DTI 16V, 2.2 i 16V, 2.5 i V6, 2.6 i V6, i 500 2.5	ch.T1086824→	<b>AK-735138</b>
Control Arm-/Trailing Arm Bush	1.6 i, 1.6 i 16V, 1.7 TD, 1.8 i 16V, 2.0 DI 16V, 2.0 DTI 16V, 2.0 i, 2.0 i 16V, 2.2 DTI 16V, 2.2 i 16V, 2.5 i V6, 2.6 i V6, i 500 2.5		<b>F8-4090</b> H1=50; H2=59; d=12; D1=36; D2=43
Control Arm-/Trailing Arm Bush	1.6 i, 1.6 i 16V, 1.7 TD, 1.8 i 16V, 2.0 DI 16V, 2.0 DTI 16V, 2.0 i, 2.0 i 16V, 2.2 DTI 16V, 2.2 i 16V, 2.5 i V6, 2.6 i V6, i 500 2.5		<b>F8-5110</b> H=61; d=12; D=47.5
Control Arm-/Trailing Arm Bush	All Models		<b>F8-5201</b> d=12; D=45; W=52
Stabiliser Mounting	1.6 i, 1.6 i 16V, 1.7 TD, 1.8 i 16V, 2.0 DI 16V, 2.0 DTI 16V, 2.0 i, 2.0 i 16V, 2.2 DTI 16V, 2.2 i 16V, 2.5 i V6	ch.XL000001→; ch.→W1999999	<b>F8-5211</b> d=16
Mounting, axle beam	1.6 i, 1.6 i 16V, 1.7 TD, 1.8 i 16V, 2.0 DI 16V, 2.0 DTI 16V, 2.0 i, 2.0 i 16V, 2.2 DTI 16V, 2.2 i 16V, 2.5 i V6, 2.6 i V6, i 500 2.5		<b>F8-5335</b> H=60; d=14; D=67
Control Arm-/Trailing Arm Bush	1.6 i, 1.6 i 16V, 1.7 TD, 1.8 i 16V, 2.0 DI 16V, 2.0 DTI 16V, 2.0 i, 2.0 i 16V, 2.2 DTI 16V, 2.2 i 16V, 2.5 i V6, 2.6 i V6, i 500 2.5		<b>F8-5336</b> H=60; d=14; D=64
Buffer, engine mounting	1.6 i, 1.6 i 16V, 1.8 i 16V, 2.0 i, 2.0 i 16V		<b>F8-5367</b>
Engine Mounting	1.6 i		<b>F8-5370</b>
Engine Mounting	1.6 i 16V, 1.8 i 16V		<b>F8-5370</b>
Top Strut Mounting	1.6 i, 1.6 i 16V, 1.7 TD, 1.8 i 16V, 2.0 i	Bearing Type: Soft Version;	<b>F8-5448</b>
Top Strut Mounting	2.0 DI 16V, 2.0 DTI 16V, 2.0 i, 2.0 i 16V, 2.2 DTI 16V, 2.2 i 16V, 2.5 i V6, 2.6 i V6, i 500 2.5	;	<b>F8-5463</b>
Belt Pulley, crankshaft	2.0 DI 16V, 2.0 DTI 16V, 2.2 DTI 16V		<b>F8-5639</b>
Rubber Buffer, suspension	1.6 i, 1.6 i 16V, 1.7 TD, 1.8 i 16V, 2.0 DI 16V, 2.0 DTI 16V, 2.0 i, 2.0 i 16V, 2.2 DTI 16V, 2.2 i 16V, 2.5 i V6	ch.T1086824→	<b>F8-5721</b> H=113
Control Arm-/Trailing Arm Bush	1.6 i, 1.6 i 16V, 1.7 TD, 1.8 i 16V, 2.0 DI 16V, 2.0 DTI 16V, 2.0 i, 2.0 i 16V, 2.2 DTI 16V, 2.2 i 16V, 2.5 i V6, 2.6 i V6, i 500 2.5		<b>F8-5723</b> H=89; d=12; D=35
Stabiliser Mounting	1.6 GL, 1.6 i, 1.6 i 16V		<b>F8-5724</b> d=14

<b>AK-735038</b>	<b>AK-735138</b>	<b>F8-4090</b>	<b>F8-5110</b>	<b>F8-5201</b>	<b>F8-5211</b>	<b>F8-5335</b>
Ref.Nr.: 344417	Ref.Nr.:	Ref.Nr.: 4566899	Ref.Nr.: 0352358	Ref.Nr.: 423121	Ref.Nr.: 0350130	Ref.Nr.: 5402630
<b>F8-5336</b>	<b>F8-5367</b>	<b>F8-5370</b>	<b>F8-5448</b>	<b>F8-5463</b>	<b>F8-5639</b>	<b>F8-5721</b>
Ref.Nr.: 90496721	Ref.Nr.: 0684703	Ref.Nr.: 0684670	Ref.Nr.: 0344523	Ref.Nr.: 0344525	Ref.Nr.: 0614411	Ref.Nr.: 436955
<b>F8-5723</b>	<b>F8-5724</b>	<b>F8-5878</b>	<b>MK-822300S</b>	<b>MK-822920</b>		
Ref.Nr.: 0423316	Ref.Nr.: 0444153	Ref.Nr.: 0344417	Ref.Nr.: 902828	Ref.Nr.: 811498203		

**Article Description****Article Nr.****Fitting Position**

<b>VECTRA B (36_)</b>		<b>09/1995 → 04/2002</b>		
Rubber Buffer, suspension	1.6 i, 1.6 i 16V, 1.7 TD, 1.8 i 16V, 2.0 DI 16V, 2.0 DTI 16V, 2.0 i, 2.0 i 16V, 2.2 DTI 16V, 2.2 i 16V, 2.5 i V6, 2.6 i V6		<b>F8-5878</b>	H=62.5; d=24; D=50
Rubber Buffer, suspension	1.6 i, 1.6 i 16V, 1.7 TD, 1.8 i 16V, 2.0 DI 16V, 2.0 DTI 16V, 2.0 i, 2.0 i 16V, 2.2 DTI 16V, 2.2 i 16V, 2.5 i V6	ch.→T1086823	<b>F8-5912</b>	H=141
Rubber Buffer, suspension	1.6 i, 1.6 i 16V, 1.7 TD, 1.8 i 16V, 2.0 DI 16V, 2.0 DTI 16V, 2.0 i, 2.0 i 16V, 2.2 DTI 16V, 2.2 i 16V, 2.5 i V6, 2.6 i V6		<b>F8-5966</b>	H=53; d=24; D=50
Control Arm-/Trailing Arm Bush	1.6 GL, 1.6 i, 1.6 i 16V, 1.7 TD, 1.8 i 16V, 2.0 DI 16V, 2.0 DTI 16V, 2.0 i, 2.0 i 16V, 2.2 DTI 16V, 2.2 i 16V, 2.5 i V6, 2.6 i V6, i 500 2.5		<b>F8-6098</b>	H=55; d=12; D=60
Rubber Buffer, suspension	1.6 GL, 1.6 i, 1.6 i 16V, 1.7 TD, 1.8 i 16V, 2.0 DI 16V, 2.0 DTI 16V, 2.0 i, 2.0 i 16V, 2.2 DTI 16V, 2.2 i 16V, 2.5 i V6, 2.6 i V6, i 500 2.5		<b>F8-6517</b>	
Stabiliser Mounting	1.6 GL, 1.7 TD, 2.5 i V6		<b>F8-6660</b>	d=16
Stabiliser Mounting	1.6 i 16V	ch.X10000001, X70000001→;  X 16 XEL, Y 16 XE	<b>F8-6660</b>	d=16
Stabiliser Mounting	1.6 i, 1.8 i 16V	ch.X10000001, X70000001→	<b>F8-6660</b>	d=16
Stabiliser Mounting	1.8 i 16V, 2.0 DI 16V, 2.0 i	ch.→W1999999, W5999999, W7999999	<b>F8-6660</b>	d=16
Stabiliser Mounting	2.0 DTI 16V	ch.→W1999999, W5999999, W7999999;  X 20 DTH	<b>F8-6660</b>	d=16
Stabiliser Mounting	2.0 i 16V	X 20 XEV	<b>F8-6660</b>	d=16
Stabiliser Mounting	2.2 i 16V		<b>F8-6660</b>	d=16
Mounting, automatic transmission	1.6 i, 1.6 i 16V, 1.8 i 16V, 2.0 DI 16V, 2.0 DTI 16V, 2.2 i 16V		<b>F8-6739</b>	
Mounting, automatic transmission	1.8 i 16V, 2.0 i 16V		<b>F8-6740</b>	
Spring Cap	1.6 GL, 1.6 i, 1.6 i 16V, 1.7 TD, 1.8 i 16V, 2.0 DI 16V, 2.0 DTI 16V, 2.0 i, 2.0 i 16V, 2.2 DTI 16V, 2.2 i 16V, 2.5 i V6, 2.6 i V6, i 500 2.5		<b>F8-7372</b>	
Repair Kit, suspension strut	All Models		<b>F8-8085</b>	
Engine Mounting	2.0 DI 16V, 2.0 DTI 16V, 2.2 DTI 16V, 2.2 i 16V		<b>F8-8183</b>	
Repair Kit, suspension strut	2.0 DI 16V, 2.0 DTI 16V, 2.2 DTI 16V, 2.5 i V6, 2.6 i V6, i 500 2.5	Bearing Type: Hard Version;	<b>F8-8214</b>	
Bellow, steering	All Models	for steering gear manufacturer: ZF; with clamps	<b>LM-10030S</b>	d1=14; d2=48; L [mm]=158
Bellow, steering	All Models	with clamps	<b>LM-10059S</b>	d1=13; d2=49; L [mm]=166
<b>VECTRA B Estate (31_)</b>		<b>11/1996 → 07/2003</b>		
Rubber Buffer, suspension	1.6 i, 1.6 i 16V, 1.8 i 16V, 2.0 DI 16V, 2.0 DTI 16V, 2.0 i, 2.0 i 16V, 2.2 DTI 16V, 2.2 i 16V, 2.5 i V6, 2.6 i V6		<b>AK-735038</b>	
Dust Cover Kit, shock absorber	1.6 i, 1.6 i 16V, 1.8 i 16V, 2.0 DI 16V, 2.0 DTI 16V, 2.0 i, 2.0 i 16V, 2.2 DTI 16V, 2.2 i 16V, 2.5 i V6, 2.6 i V6, i 500 2.5	ch.T1086824→	<b>AK-735138</b>	

<b>AK-735038</b>	<b>AK-735138</b>	<b>F8-4090</b>	<b>F8-5878</b>	<b>F8-5912</b>	<b>F8-5966</b>	<b>F8-6098</b>
Ref.Nr.: 344417	Ref.Nr.:	Ref.Nr.: 4566899	Ref.Nr.: 0344417	Ref.Nr.: 0436933	Ref.Nr.: 0344418	Ref.Nr.: 0423302
<b>F8-6517</b>	<b>F8-6660</b>	<b>F8-6739</b>	<b>F8-6740</b>	<b>F8-7372</b>	<b>F8-8085</b>	<b>F8-8183</b>
Ref.Nr.: 90468618	Ref.Nr.: 90496706	Ref.Nr.: 90495513	Ref.Nr.: 5682508	Ref.Nr.: 0344591	Ref.Nr.: 344523	Ref.Nr.: 684684
<b>F8-8214</b>	<b>LM-10030S</b>	<b>LM-10059S</b>				
Ref.Nr.: 312510	Ref.Nr.: 90512778	Ref.Nr.: 520738				

Article Description



Article Nr.

Fitting Position



VECTRA B Estate (31_)		11/1996 → 07/2003	
Control Arm-/Trailing Arm Bush	1.6 i, 1.6 i 16V, 1.8 i 16V, 2.0 DI 16V, 2.0 DTI 16V, 2.0 i, 2.0 i 16V, 2.2 DTI 16V, 2.2 i 16V, 2.5 i V6, 2.6 i V6, i 500 2.5		F8-4090
Control Arm-/Trailing Arm Bush	1.6 i, 1.6 i 16V, 1.8 i 16V, 2.0 DI 16V, 2.0 DTI 16V, 2.0 i, 2.0 i 16V, 2.2 DTI 16V, 2.2 i 16V, 2.5 i V6, 2.6 i V6, i 500 2.5		F8-5110
Control Arm-/Trailing Arm Bush	All Models		F8-5201
Stabiliser Mounting	1.6 i, 1.6 i 16V, 1.8 i 16V, 2.0 DI 16V, 2.0 DTI 16V, 2.0 i 16V, 2.2 DTI 16V, 2.2 i 16V, 2.5 i V6	ch.XL000001→; ch.→W1999999	F8-5211
Mounting, axle beam	1.6 i, 1.6 i 16V, 1.8 i 16V, 2.0 DI 16V, 2.0 DTI 16V, 2.0 i, 2.0 i 16V, 2.2 DTI 16V, 2.2 i 16V, 2.5 i V6, 2.6 i V6, i 500 2.5		F8-5335
Control Arm-/Trailing Arm Bush	1.6 i, 1.6 i 16V, 1.8 i 16V, 2.0 DI 16V, 2.0 DTI 16V, 2.0 i, 2.0 i 16V, 2.2 DTI 16V, 2.2 i 16V, 2.5 i V6, 2.6 i V6, i 500 2.5		F8-5336
Buffer, engine mounting	1.6 i, 1.6 i 16V, 1.8 i 16V, 2.0 i 16V		F8-5367
Engine Mounting	1.6 i		F8-5370
Engine Mounting	1.6 i 16V, 1.8 i 16V		F8-5370
Top Strut Mounting	1.6 i, 1.6 i 16V, 1.8 i 16V, 2.0 i	Bearing Type: Soft Version;	F8-5448
Top Strut Mounting	2.0 DI 16V, 2.0 DTI 16V, 2.0 i, 2.0 i 16V, 2.2 DTI 16V, 2.2 i 16V, 2.5 i V6, 2.6 i V6, i 500 2.5		F8-5463
Belt Pulley, crankshaft	2.0 DI 16V, 2.0 DTI 16V, 2.2 DTI 16V		F8-5639
Rubber Buffer, suspension	1.6 i, 1.6 i 16V, 1.8 i 16V, 2.0 DI 16V, 2.0 DTI 16V, 2.0 i 16V, 2.2 DTI 16V, 2.2 i 16V, 2.5 i V6	ch.T1086824→	F8-5721
Control Arm-/Trailing Arm Bush	1.6 i, 1.6 i 16V, 1.8 i 16V, 2.0 DI 16V, 2.0 DTI 16V, 2.0 i, 2.0 i 16V, 2.2 DTI 16V, 2.2 i 16V, 2.5 i V6, 2.6 i V6, i 500 2.5		F8-5723
Stabiliser Mounting	1.6 i, 1.6 i 16V		F8-5724
Rubber Buffer, suspension	1.6 i, 1.6 i 16V, 1.7 TD, 1.8 i 16V, 2.0 DI 16V, 2.0 DTI 16V, 2.0 i, 2.0 i 16V, 2.2 DTI 16V, 2.2 i 16V, 2.5 i V6, 2.6 i V6		F8-5878
Rubber Buffer, suspension	1.6 i, 1.6 i 16V, 1.8 i 16V, 2.0 DI 16V, 2.0 DTI 16V, 2.0 i 16V, 2.2 DTI 16V, 2.2 i 16V, 2.5 i V6	ch.→T1086823	F8-5912
Rubber Buffer, suspension	1.6 i, 1.6 i 16V, 1.7 TD, 1.8 i 16V, 2.0 DI 16V, 2.0 DTI 16V, 2.0 i, 2.0 i 16V, 2.2 DTI 16V, 2.2 i 16V, 2.5 i V6, 2.6 i V6		F8-5966
Control Arm-/Trailing Arm Bush	All Models		F8-6098
Rubber Buffer, suspension	All Models		F8-6517
Stabiliser Mounting	1.6 i 16V	ch.X10000001, X70000001→;  X 16	F8-6660
Stabiliser Mounting	1.6 i, 1.8 i 16V	ch.X10000001, X70000001→	F8-6660

<b>F8-4090</b>	<b>F8-5110</b>	<b>F8-5201</b>	<b>F8-5211</b>	<b>F8-5335</b>	<b>F8-5336</b>	<b>F8-5367</b>
Ref.Nr.: 4566899	Ref.Nr.: 0352358	Ref.Nr.: 423121	Ref.Nr.: 0350130	Ref.Nr.: 5402630	Ref.Nr.: 90496721	Ref.Nr.: 0684703
<b>F8-5370</b>	<b>F8-5448</b>	<b>F8-5463</b>	<b>F8-5639</b>	<b>F8-5721</b>	<b>F8-5723</b>	<b>F8-5724</b>
Ref.Nr.: 0684670	Ref.Nr.: 0344523	Ref.Nr.: 0344525	Ref.Nr.: 0614411	Ref.Nr.: 436955	Ref.Nr.: 0423316	Ref.Nr.: 0444153
<b>F8-5878</b>	<b>F8-5912</b>	<b>F8-5966</b>	<b>F8-6098</b>	<b>F8-6517</b>	<b>F8-6660</b>	
Ref.Nr.: 0344417	Ref.Nr.: 0436933	Ref.Nr.: 0344418	Ref.Nr.: 0423302	Ref.Nr.: 90468618	Ref.Nr.: 90496706	

**Article Description****Article Nr.****Fitting Position**

<b>VECTRA B Estate (31_)</b>			<b>11/1996 → 07/2003</b>		
Stabiliser Mounting	1.7 TD, 2.5 i V6		<b>F8-6660</b>		d=16
Stabiliser Mounting	1.8 i 16V, 2.0 DI 16V, 2.0 i	ch.→W1999999, W5999999, W7999999	<b>F8-6660</b>		d=16
Stabiliser Mounting	2.0 DTI 16V	ch.→W1999999, W5999999, W7999999;  X 20 DTH	<b>F8-6660</b>		d=16
Stabiliser Mounting	2.0 i 16V	X 20 XEV	<b>F8-6660</b>		d=16
Stabiliser Mounting	2.2 i 16V		<b>F8-6660</b>		d=16
Mounting, automatic transmission	1.6 i, 1.6 i 16V, 1.8 i 16V, 2.0 DI 16V, 2.0 DTI 16V, 2.2 i 16V		<b>F8-6739</b>		
Mounting, automatic transmission	1.8 i 16V, 2.0 i 16V		<b>F8-6740</b>		
Spring Cap	All Models		<b>F8-7372</b>		
Repair Kit, suspension strut	All Models		<b>F8-8085</b>		
Engine Mounting	2.0 DI 16V, 2.0 DTI 16V, 2.2 DTI 16V, 2.2 i 16V		<b>F8-8183</b>		
Repair Kit, suspension strut	2.0 DI 16V, 2.0 DTI 16V, 2.2 DTI 16V, 2.5 i V6, 2.6 i V6, 1500 2.5	Bearing Type: Hard Version;	<b>F8-8214</b>		
Bellow, steering	All Models	for steering gear manufacturer: ZF; with clamps	<b>LM-10030S</b>		d1=14; d2=48; L [mm]=158
Bellow, steering	All Models	with clamps	<b>LM-10059S</b>		d1=13; d2=49; L [mm]=166
<b>VECTRA B Hatchback (38_)</b>			<b>10/1995 → 07/2003</b>		
Rubber Buffer, suspension	1.6 i, 1.6 i 16V, 1.7 TD, 1.8 i 16V, 2.0 DI 16V, 2.0 DTI 16V, 2.0 i, 2.0 i 16V, 2.2 DTI 16V, 2.2 i 16V, 2.5 i V6, 2.6 i V6		<b>AK-735038</b>		
Dust Cover Kit, shock absorber	1.6 i, 1.6 i 16V, 1.7 TD, 1.8 i 16V, 2.0 DI 16V, 2.0 DTI 16V, 2.0 i, 2.0 i 16V, 2.2 DTI 16V, 2.2 i 16V, 2.5 i V6, 2.6 i V6	ch.T1086824→	<b>AK-735138</b>		
Control Arm-/Trailing Arm Bush	1.6 i, 1.6 i 16V, 1.7 TD, 1.8 i 16V, 2.0 DI 16V, 2.0 DTI 16V, 2.0 i, 2.0 i 16V, 2.2 DTI 16V, 2.2 i 16V, 2.5 i V6, 2.6 i V6		<b>F8-4090</b>		H1=50; H2=59; d=12; D1=36; D2=43
Control Arm-/Trailing Arm Bush	1.6 i, 1.6 i 16V, 1.7 TD, 1.8 i 16V, 2.0 DI 16V, 2.0 DTI 16V, 2.0 i, 2.0 i 16V, 2.2 DTI 16V, 2.2 i 16V, 2.5 i V6, 2.6 i V6		<b>F8-5110</b>		H=61; d=12; D=47.5
Control Arm-/Trailing Arm Bush	All Models		<b>F8-5201</b>		d=12; D=45; W=52
Stabiliser Mounting	1.6 i, 1.6 i 16V, 1.7 TD, 1.8 i 16V, 2.0 DI 16V, 2.0 DTI 16V, 2.0 i 16V, 2.5 i V6	ch.XL000001→; ch.→W1999999	<b>F8-5211</b>		d=16
Mounting, axle beam	1.6 i, 1.6 i 16V, 1.7 TD, 1.8 i 16V, 2.0 DI 16V, 2.0 DTI 16V, 2.0 i, 2.0 i 16V, 2.2 DTI 16V, 2.2 i 16V, 2.5 i V6, 2.6 i V6		<b>F8-5335</b>		H=60; d=14; D=67
Control Arm-/Trailing Arm Bush	1.6 i, 1.6 i 16V, 1.7 TD, 1.8 i 16V, 2.0 DI 16V, 2.0 DTI 16V, 2.0 i, 2.0 i 16V, 2.2 DTI 16V, 2.2 i 16V, 2.5 i V6, 2.6 i V6		<b>F8-5336</b>		H=60; d=14; D=64
Buffer, engine mounting	1.6 i, 1.6 i 16V, 1.8 i 16V, 2.0 i, 2.0 i 16V		<b>F8-5367</b>		

<b>AK-735038</b>	<b>AK-735138</b>	<b>F8-4090</b>	<b>F8-5110</b>	<b>F8-5201</b>	<b>F8-5211</b>	<b>F8-5335</b>
Ref.Nr.: 344417	Ref.Nr.:	Ref.Nr.: 4566899	Ref.Nr.: 0352358	Ref.Nr.: 423121	Ref.Nr.: 0350130	Ref.Nr.: 5402630
<b>F8-5336</b>	<b>F8-5367</b>	<b>F8-5370</b>	<b>F8-6660</b>	<b>F8-6739</b>	<b>F8-6740</b>	<b>F8-7372</b>
Ref.Nr.: 90496721	Ref.Nr.: 0684703	Ref.Nr.: 0684670	Ref.Nr.: 90496706	Ref.Nr.: 90495513	Ref.Nr.: 5682508	Ref.Nr.: 0344591
<b>F8-8085</b>	<b>F8-8183</b>	<b>F8-8214</b>	<b>LM-10030S</b>	<b>LM-10059S</b>		
Ref.Nr.: 344523	Ref.Nr.: 684684	Ref.Nr.: 312510	Ref.Nr.: 90512778	Ref.Nr.: 520738		

Article Description



Article Nr.

Fitting Position



**VECTRA B Hatchback (38\_)**

10/1995 → 07/2003

Engine Mounting	1.6 i	⊛	F8-5370		
Engine Mounting	1.6 i 16V, 1.8 i 16V		F8-5370		
Top Strut Mounting	1.6 i, 1.6 i 16V, 1.7 TD, 1.8 i 16V, 2.0 i	Bearing Type: Soft Version;	F8-5448		
Top Strut Mounting	2.0 DI 16V, 2.0 DTI 16V, 2.0 i, 2.0 i 16V, 2.2 DTI 16V, 2.2 i 16V, 2.5, 2.5 i V6, 2.6 i V6	;	F8-5463		
Belt Pulley, crankshaft	2.0 DI 16V, 2.0 DTI 16V, 2.2 DTI 16V		F8-5639		
Rubber Buffer, suspension	1.6 i, 1.6 i 16V, 1.7 TD, 1.8 i 16V, 2.0 DI 16V, 2.0 DTI 16V, 2.0 i, 2.0 i 16V, 2.5 i V6	ch.T1086824→	F8-5721		H=113
Control Arm-/Trailing Arm Bush	1.6 i, 1.6 i 16V, 1.7 TD, 1.8 i 16V, 2.0 DI 16V, 2.0 DTI 16V, 2.0 i, 2.0 i 16V, 2.2 DTI 16V, 2.2 i 16V, 2.5 i V6, 2.6 i V6		F8-5723		H=89; d=12; D=35
Stabiliser Mounting	1.6 i, 1.6 i 16V		F8-5724		d=14
Rubber Buffer, suspension	All Models		F8-5878		H=62.5; d=24; D=50
Rubber Buffer, suspension	1.6 i, 1.6 i 16V, 1.7 TD, 1.8 i 16V, 2.0 DI 16V, 2.0 DTI 16V, 2.0 i, 2.0 i 16V, 2.5 i V6	ch.→T1086823	F8-5912		H=141
Rubber Buffer, suspension	All Models		F8-5966		H=53; d=24; D=50
Control Arm-/Trailing Arm Bush	All Models		F8-6098		H=55; d=12; D=60
Rubber Buffer, suspension	All Models	⊛	F8-6517		
Stabiliser Mounting	1.6 i 16V	ch.X10000001, X70000001→;  X 16 XEL, Y 16 XE	F8-6660		d=16
Stabiliser Mounting	1.6 i, 1.8 i 16V	ch.X10000001, X70000001→	F8-6660		d=16
Stabiliser Mounting	1.7 TD, 2.5 i V6		F8-6660		d=16
Stabiliser Mounting	1.8 i 16V, 2.0 DI 16V, 2.0 i	ch.→W1999999, W5999999, W7999999	F8-6660		d=16
Stabiliser Mounting	2.0 DTI 16V	ch.→W1999999, W5999999, W7999999;  X 20 DTH	F8-6660		d=16
Stabiliser Mounting	2.0 i 16V	X 20 XEV	F8-6660		d=16
Stabiliser Mounting	2.2 i 16V		F8-6660		d=16
Mounting, automatic transmission	1.6 i, 1.6 i 16V, 1.8 i 16V, 2.0 DI 16V, 2.0 DTI 16V, 2.2 i 16V		F8-6739		
Mounting, automatic transmission	1.8 i 16V, 2.0 i 16V		F8-6740		
Spring Cap	All Models		F8-7372		
Repair Kit, suspension strut	All Models		F8-8085		
Engine Mounting	2.0 DI 16V, 2.0 DTI 16V, 2.2 DTI 16V, 2.2 i 16V		F8-8183		
Repair Kit, suspension strut	2.0 DI 16V, 2.0 DTI 16V, 2.2 DTI 16V, 2.5, 2.5 i V6, 2.6 i V6	Bearing Type: Hard Version;	F8-8214		
Bellow, steering	All Models	for steering gear manufacturer: ZF; with clamps	LM-10030S		d1=14; d2=48; L [mm]=158
Bellow, steering	All Models	with clamps	LM-10059S		d1=13; d2=49; L [mm]=166

<b>F8-5370</b>	<b>F8-5448</b>	<b>F8-5463</b>	<b>F8-5639</b>	<b>F8-5721</b>	<b>F8-5723</b>	<b>F8-5724</b>
Ref.Nr.: 0684670	Ref.Nr.: 0344523	Ref.Nr.: 0344525	Ref.Nr.: 0614411	Ref.Nr.: 436955	Ref.Nr.: 0423316	Ref.Nr.: 0444153
<b>F8-5878</b>	<b>F8-5912</b>	<b>F8-5966</b>	<b>F8-6098</b>	<b>F8-6517</b>	<b>F8-6660</b>	<b>F8-6739</b>
Ref.Nr.: 0344417	Ref.Nr.: 0436933	Ref.Nr.: 0344418	Ref.Nr.: 0423302	Ref.Nr.: 90468618	Ref.Nr.: 90496706	Ref.Nr.: 90495513
<b>F8-6740</b>	<b>F8-7372</b>	<b>F8-8085</b>	<b>F8-8183</b>	<b>F8-8214</b>	<b>LM-10030S</b>	<b>LM-10059S</b>
Ref.Nr.: 5682508	Ref.Nr.: 0344591	Ref.Nr.: 344523	Ref.Nr.: 684684	Ref.Nr.: 312510	Ref.Nr.: 90512778	Ref.Nr.: 520738

**Article Description****Article Nr.****Fitting Position****VECTRA C** **04/2002 → 09/2008**

Dust Cover Kit, shock absorber	1.6, 1.6 16V, 1.8, 1.8 16V, 1.9 CDTI, 2.0 16V Turbo, 2.0 DTI 16V, 2.2 16V, 2.2 direct, 2.2 DTI 16V, 2.8 V6 Turbo, 3.0 CDTi, 3.2 V6	ST	AK-735251				
Alternator Freewheel Clutch	1.6 16V, 1.8, 1.8 16V		F5-1050				
Alternator Freewheel Clutch	2.0 16V Turbo, 2.2 16V, 2.2 direct		F5-1079				
Alternator Freewheel Clutch	1.9 CDTI		F5-1102				
Alternator Freewheel Clutch	1.9 CDTI		F5-1123				
Control Arm-/Trailing Arm Bush	1.8 16V, 2.0 16V Turbo, 2.0 DTI 16V, 2.2 16V, 2.2 DTI 16V, 3.0 CDTI		F8-4090				H1=50; H2=59; d=12; D1=36; D2=43
Belt Pulley, crankshaft	2.0 DTI 16V, 2.2 DTI 16V		F8-5639				
Control Arm-/Trailing Arm Bush	1.6, 1.6 16V, 1.8, 1.8 16V, 1.9 CDTI, 2.0 16V Turbo, 2.0 DTI 16V, 2.2 16V, 2.2 direct, 2.2 DTI 16V, 2.8 V6 Turbo, 3.0 CDTi, 3.2 V6		F8-6447				
Anti-Friction Bearing	1.6, 1.6 16V, 1.8, 1.8 16V, 1.9 CDTI, 2.0 16V Turbo, 2.0 DTI 16V, 2.2 16V, 2.2 direct, 2.2 DTI 16V, 2.8 V6 Turbo, 3.0 CDTi, 3.2 V6		F8-7172				
Top Strut Mounting	1.6, 1.6 16V, 1.8, 1.8 16V, 1.9 CDTI, 2.0 16V Turbo, 2.0 DTI 16V, 2.2 16V, 2.2 direct, 2.2 DTI 16V, 2.8 V6 Turbo, 3.0 CDTi, 3.2 V6		F8-7329				
Top Strut Mounting	1.6, 1.6 16V, 1.8, 1.8 16V, 1.9 CDTI, 2.0 16V Turbo, 2.0 DTI 16V, 2.2 16V, 2.2 direct, 2.2 DTI 16V, 2.8 V6 Turbo, 3.0 CDTi, 3.2 V6		F8-7330				
Control Arm-/Trailing Arm Bush	1.6, 1.6 16V, 1.8, 1.8 16V, 1.9 CDTI, 2.0 16V Turbo, 2.0 DTI 16V, 2.2 16V, 2.2 direct, 2.2 DTI 16V, 2.8 V6 Turbo, 3.0 CDTi, 3.2 V6		F8-7373				d=12; L=52; L1=32; D=45.5
Protective Cap/Bellow, shock absorber	All Models		F8-7663				H=205
Rubber Buffer, suspension	1.6, 1.6 16V, 1.8, 1.8 16V, 1.9 CDTI, 2.0 16V Turbo, 2.0 DTI 16V, 2.2 16V, 2.2 direct, 2.2 DTI 16V, 2.8 V6 Turbo, 3.0 CDTi, 3.2 V6	ch.21000000, 28000000→	F8-7699				H=50
Stabiliser Mounting	1.6, 1.6 16V, 1.8, 1.8 16V, 1.9 CDTI, 2.0 16V Turbo, 2.0 DTI 16V, 2.2 16V, 2.2 direct, 2.2 DTI 16V, 2.8 V6 Turbo, 3.0 CDTi, 3.2 V6		F8-7919				d=17
Stabiliser Mounting	1.6, 1.6 16V, 1.8, 1.8 16V, 1.9 CDTI, 2.0 16V Turbo, 2.0 DTI 16V, 2.2 16V, 2.2 direct, 2.2 DTI 16V, 2.8 V6 Turbo, 3.0 CDTi, 3.2 V6		F8-7925				
Mounting, automatic transmission	1.9 CDTI, 2.0 DTI 16V, 2.2 DTI 16V		F8-8170				

**VECTRA C Estate** **10/2003 →**

Dust Cover Kit, shock absorber	1.6 16V, 1.8, 1.9 CDTI, 2.0 DTI, 2.0 Turbo, 2.2 direct, 2.2 DTI, 2.8 V6 Turbo, 3.0 V6 CDTI, 3.2 V6	ST	AK-735251				
Alternator Freewheel Clutch	1.6 16V, 1.8		F5-1050				
Alternator Freewheel Clutch	2.0 Turbo, 2.2 direct		F5-1079				
Alternator Freewheel Clutch	1.9 CDTI		F5-1102				



Article Description



Article Nr.

Fitting Position



<b>VECTRA C Estate</b>		<b>10/2003 →</b>	
Alternator Freewheel Clutch	1.9 CDTI	<b>F5-1123</b>	
Control Arm-/Trailing Arm Bush	1.8, 2.0 DTI, 2.0 Turbo, 2.2 direct, 2.2 DTI, 3.0 V6 CDTI, 3.2 V6	<b>F8-4090</b>	H1=50; H2=59; d=12; D1=36; D2=43
Belt Pulley, crankshaft	2.0 DTI, 2.2 DTI	<b>F8-5639</b>	
Control Arm-/Trailing Arm Bush	1.6, 1.6 16V, 1.8, 1.9 CDTI, 2.0 DTI, 2.0 Turbo, 2.2 direct, 2.2 DTI, 2.8 V6 Turbo, 3.0 V6 CDTI, 3.2 V6	<b>F8-6447</b>	
Anti-Friction Bearing	1.6, 1.6 16V, 1.8, 1.9 CDTI, 2.0 DTI, 2.0 Turbo, 2.2 direct, 2.2 DTI, 2.8 V6 Turbo, 3.0 V6 CDTI, 3.2 V6	<b>F8-7172</b>	
Top Strut Mounting	1.6, 1.6 16V, 1.8, 1.9 CDTI, 2.0 DTI, 2.0 Turbo, 2.2 direct, 2.2 DTI, 2.8 V6 Turbo, 3.0 V6 CDTI, 3.2 V6	<b>F8-7329</b>	
Top Strut Mounting	1.6, 1.6 16V, 1.8, 1.9 CDTI, 2.0 DTI, 2.0 Turbo, 2.2 direct, 2.2 DTI, 2.8 V6 Turbo, 3.0 V6 CDTI, 3.2 V6	<b>F8-7330</b>	
Control Arm-/Trailing Arm Bush	1.6, 1.6 16V, 1.8, 1.9 CDTI, 2.0 DTI, 2.0 Turbo, 2.2 direct, 2.2 DTI, 2.8 V6 Turbo, 3.0 V6 CDTI, 3.2 V6	<b>F8-7373</b>	d=12; L=52; L1=32; D=45.5
Protective Cap/Bellow, shock absorber	1.6, 1.6 16V, 1.8, 1.9 CDTI, 2.0 DTI, 2.0 Turbo, 2.2 direct, 2.2 DTI, 2.8 V6 Turbo, 3.0 V6 CDTI, 3.2 V6	<b>F8-7663</b>	H=205
Rubber Buffer, suspension	1.6, 1.6 16V, 1.8, 1.9 CDTI, 2.0 DTI, 2.0 Turbo, 2.2 direct, 2.2 DTI, 2.8 V6 Turbo, 3.0 V6 CDTI, 3.2 V6	<b>F8-7699</b>	H=50
Stabiliser Mounting	1.6, 1.6 16V, 1.8, 1.9 CDTI, 2.0 DTI, 2.0 Turbo, 2.2 direct, 2.2 DTI, 2.8 V6 Turbo, 3.0 V6 CDTI, 3.2 V6	<b>F8-7919</b>	d=17
Stabiliser Mounting	1.6, 1.8, 1.9 CDTI, 2.0 DTI, 2.0 Turbo, 2.2 direct, 2.2 DTI, 2.8 V6 Turbo, 3.0 V6 CDTI, 3.2 V6	<b>F8-7925</b>	
Mounting, automatic transmission	1.9 CDTI, 2.0 DTI, 2.2 DTI	<b>F8-8170</b>	
<b>VECTRA C GTS</b>		<b>08/2002 → 12/2006</b>	
Dust Cover Kit, shock absorber	1.6, 1.8, 1.8 16V, 1.9 CDTI, 2.0 16V Turbo, 2.0 DTI 16V, 2.2 16V, 2.2 direct, 2.2 DTI 16V, 2.8 V6 Turbo, 3.0 CDTI, 3.2 V6	<b>AK-735253</b>	
Alternator Freewheel Clutch	1.6, 1.8 16V	<b>F5-1050</b>	
Alternator Freewheel Clutch	2.0 16V Turbo, 2.2 16V, 2.2 direct	<b>F5-1079</b>	
Alternator Freewheel Clutch	1.9 CDTI	<b>F5-1102</b>	
Alternator Freewheel Clutch	1.9 CDTI	<b>F5-1123</b>	
Control Arm-/Trailing Arm Bush	1.8 16V, 2.0 16V Turbo, 2.0 DTI 16V, 2.2 16V, 2.2 DTI 16V, 3.0 CDTI, 3.2 V6	<b>F8-4090</b>	H1=50; H2=59; d=12; D1=36; D2=43
Belt Pulley, crankshaft	2.0 DTI 16V, 2.2 DTI 16V	<b>F8-5639</b>	
Control Arm-/Trailing Arm Bush	1.6, 1.8, 1.8 16V, 1.9 CDTI, 2.0 16V Turbo, 2.0 DTI 16V, 2.2 16V, 2.2 direct, 2.2 DTI 16V, 2.8 V6 Turbo, 3.0 CDTI, 3.2 V6	<b>F8-6447</b>	
Anti-Friction Bearing	1.6, 1.8, 1.8 16V, 1.9 CDTI, 2.0 16V Turbo, 2.0 DTI 16V, 2.2 16V, 2.2 direct, 2.2 DTI 16V, 2.8 V6 Turbo, 3.0 CDTI, 3.2 V6	<b>F8-7172</b>	

<b>AK-735253</b>	<b>F5-1050</b>	<b>F5-1079</b>	<b>F5-1102</b>	<b>F5-1123</b>	<b>F8-4090</b>	<b>F8-5639</b>
Ref.Nr.: 344426	Ref.Nr.: 1204412	Ref.Nr.: 1204376	Ref.Nr.: 1204151	Ref.Nr.: 9948513	Ref.Nr.: 4566899	Ref.Nr.: 0614411
<b>F8-6447</b>	<b>F8-7172</b>	<b>F8-7329</b>	<b>F8-7330</b>	<b>F8-7373</b>	<b>F8-7663</b>	<b>F8-7699</b>
Ref.Nr.: 12786412	Ref.Nr.: 9191181	Ref.Nr.: 344529	Ref.Nr.: 344537	Ref.Nr.: 24469643	Ref.Nr.: 344435	Ref.Nr.: 13117280
<b>F8-7919</b>	<b>F8-7925</b>	<b>F8-8170</b>				
Ref.Nr.: 444160	Ref.Nr.: 350145	Ref.Nr.: 9156933				



**Article Description****Article Nr.****Fitting Position**

<b>VECTRA C GTS</b>			<b>08/2002 → 12/2006</b>		
Top Strut Mounting	1.6, 1.8, 1.8 16V, 1.9 CDTI, 2.0 16V Turbo, 2.0 DTI 16V, 2.2 16V, 2.2 direct, 2.2 DTI 16V, 2.8 V6 Turbo, 3.0 CDTI, 3.2 V6		<b>F8-7329</b>		
Top Strut Mounting	1.6, 1.8, 1.8 16V, 1.9 CDTI, 2.0 16V Turbo, 2.0 DTI 16V, 2.2 16V, 2.2 direct, 2.2 DTI 16V, 2.8 V6 Turbo, 3.0 CDTI, 3.2 V6		<b>F8-7330</b>		
Control Arm-/Trailing Arm Bush	1.6, 1.8, 1.8 16V, 1.9 CDTI, 2.0 16V Turbo, 2.0 DTI 16V, 2.2 16V, 2.2 direct, 2.2 DTI 16V, 2.8 V6 Turbo, 3.0 CDTI, 3.2 V6		<b>F8-7373</b>		d=12; L=52; L1=32; D=45.5
Protective Cap/Bellow, shock absorber	1.6, 1.8, 1.8 16V, 1.9 CDTI, 2.0 16V Turbo, 2.0 DTI 16V, 2.2 16V, 2.2 direct, 2.2 DTI 16V, 2.8 V6 Turbo, 3.0 CDTI, 3.2 V6		<b>F8-7663</b>		H=205
Rubber Buffer, suspension	1.6, 1.8, 1.8 16V, 1.9 CDTI, 2.0 16V Turbo, 2.0 DTI 16V, 2.2 16V, 2.2 direct, 2.2 DTI 16V, 2.8 V6 Turbo, 3.0 CDTI, 3.2 V6	ch.21000000, 28000000→	<b>F8-7699</b>		H=50
Stabiliser Mounting	1.6, 1.8, 1.8 16V, 1.9 CDTI, 2.0 16V Turbo, 2.0 DTI 16V, 2.2 16V, 2.2 direct, 2.2 DTI 16V, 2.8 V6 Turbo, 3.0 CDTI, 3.2 V6		<b>F8-7919</b>		d=17
Stabiliser Mounting	1.6, 1.8, 1.8 16V, 1.9 CDTI, 2.0 16V Turbo, 2.0 DTI 16V, 2.2 16V, 2.2 direct, 2.2 DTI 16V, 2.8 V6 Turbo, 3.0 CDTI, 3.2 V6		<b>F8-7925</b>		
Mounting, automatic transmission	1.9 CDTI, 2.0 DTI 16V, 2.2 DTI 16V		<b>F8-8170</b>		
<b>VIVARO Combi (J7)</b>			<b>08/2001 →</b>		
Alternator Freewheel Clutch	1.9 DI, 1.9 DTI, 2.0 16V, 2.0 ECOTEC, 2.5 CDTI, 2.5 DTI		<b>F5-1025</b>		
Alternator Freewheel Clutch	1.9 DI, 1.9 DTI, 2.0 16V, 2.0 ECOTEC		<b>F5-1036</b>		
Alternator Freewheel Clutch	2.0 CDTI		<b>F5-1110</b>		
Top Strut Mounting	All Models		<b>F8-6196</b>		
Top Strut Mounting	All Models		<b>F8-6197</b>		
Bellow Set, steering	All Models	with clamps	<b>F8-6478</b>		d1=13; d2=54.5; L [mm]=215
Mounting, axle beam	1.9 DTI, 2.0 16V, 2.0 CDTI, 2.0 ECOTEC, 2.5 CDTI, 2.5 DTI		<b>F8-6661</b>		
Engine Mounting	1.9 DI, 1.9 DTI, 2.0 16V, 2.0 ECOTEC		<b>F8-6690</b>		
Engine Mounting	1.9 DI, 1.9 DTI, 2.0 16V, 2.0 ECOTEC		<b>F8-6691</b>		
Engine Mounting	2.0 CDTI	M9R 780, M9R 784, M9R 786, M9R 788; not for  M9R630, M9R692	<b>F8-6691</b>		
Engine Mounting	2.0 CDTI	M9R 780; not for  M9R630, M9R692	<b>F8-6691</b>		
Engine Mounting	1.9 DI, 1.9 DTI, 2.0 16V, 2.0 ECOTEC		<b>F8-6692</b>		
Engine Mounting	1.9 DI, 1.9 DTI, 2.0 16V, 2.0 ECOTEC		<b>F8-6693</b>		
Anti-Friction Bearing	1.9 DTI, 2.0 16V, 2.5 CDTI, 2.5 DTI		<b>F8-7151</b>		H1=15; H2=12; d=16; D=52

<b>F5-1025</b>	<b>F5-1036</b>	<b>F5-1110</b>	<b>F8-6196</b>	<b>F8-6197</b>	<b>F8-6478</b>	<b>F8-6661</b>
Ref.Nr.: 23151-00Q0B	Ref.Nr.: 23151-00Q0A	Ref.Nr.: 8200489514	Ref.Nr.: 54320-00QAA	Ref.Nr.: 7701207491SK	Ref.Nr.: 48203-00QAE	Ref.Nr.: 4412907
<b>F8-6690</b>	<b>F8-6691</b>	<b>F8-6692</b>	<b>F8-6693</b>	<b>F8-7151</b>	<b>F8-7329</b>	<b>F8-7330</b>
Ref.Nr.: 11323-00QAA	Ref.Nr.: 11246-00QAB	Ref.Nr.: 11356-00QAA	Ref.Nr.: 11238-00QAA	Ref.Nr.: 4408056	Ref.Nr.: 344529	Ref.Nr.: 344537
<b>F8-7373</b>	<b>F8-7652</b>	<b>F8-7663</b>	<b>F8-7699</b>	<b>F8-7919</b>	<b>F8-7925</b>	<b>F8-8170</b>
Ref.Nr.: 24469643	Ref.Nr.: 93161258	Ref.Nr.: 344435	Ref.Nr.: 13117280	Ref.Nr.: 444160	Ref.Nr.: 350145	Ref.Nr.: 9156933

Article Description

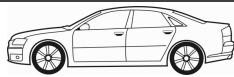

Article Nr.

Fitting Position



<b>VIVARO Combi (J7)</b>			<b>08/2001 →</b>		
Belt Pulley, crankshaft	1.9 DI	F9Q 762; Number of Ribs: 4; Parameter: 5PK;	<b>F8-7652</b>		Belt Pulley Ø [mm]=151; H1=25
Belt Pulley, crankshaft	1.9 DTI	F9Q 760; Number of Ribs: 4; Parameter: 5PK;	<b>F8-7652</b>		Belt Pulley Ø [mm]=151; H1=25
Engine Mounting	2.0 CDTI, 2.5 CDTI, 2.5 DTI		<b>F8-7733</b>	⊕	
Engine Mounting	2.0 CDTI, 2.5 CDTI, 2.5 DTI		<b>F8-7736</b>	⬇	
Engine Mounting	2.0 CDTI		<b>F8-7737</b>	⊕↑	
Control Arm-/Trailing Arm Bush	1.9 DI	F9Q 762	<b>F8-7988</b>	⊕ ⊕	
Control Arm-/Trailing Arm Bush	1.9 DTI, 2.0 16V, 2.0 ECOTEC, 2.5 CDTI, 2.5 DTI		<b>F8-7988</b>	⊕ ⊕	
Control Arm-/Trailing Arm Bush	2.0 CDTI	M9R 780	<b>F8-7988</b>	⊕ ⊕	
Control Arm-/Trailing Arm Bush	2.0 CDTI	M9R 782	<b>F8-7988</b>	⊕ ⊕	
<b>VIVARO Box (F7)</b>			<b>08/2001 →</b>		
Alternator Freewheel Clutch	1.9 DI, 1.9 DTI, 2.0 16V, 2.0 ECOTEC, 2.5 CDTI, 2.5 DTI		<b>F5-1025</b>		
Alternator Freewheel Clutch	1.9 DI, 1.9 DTI, 2.0 16V, 2.0 ECOTEC		<b>F5-1036</b>		
Alternator Freewheel Clutch	2.0 CDTI		<b>F5-1110</b>		
Top Strut Mounting	All Models		<b>F8-6196</b>	⊕ ⊕	
Top Strut Mounting	All Models		<b>F8-6197</b>	⊕ ⊕	
Bellow Set, steering	1.9 DI, 1.9 DTI, 2.0 16V, 2.0 CDTI, 2.0 ECOTEC, 2.5 CDTI, 2.5 DTI	with clamps	<b>F8-6478</b>	⊕ ⊕	d1=13; d2=54,5; L [mm]=215
Mounting, axle beam	1.9 DI, 1.9 DTI, 2.0 16V, 2.0 CDTI, 2.0 ECOTEC, 2.5 CDTI, 2.5 DTI		<b>F8-6661</b>	⊕ ⊕	
Engine Mounting	1.9 DI, 1.9 DTI, 2.0 16V, 2.0 ECOTEC		<b>F8-6690</b>	⊕	
Engine Mounting	1.9 DI, 1.9 DTI, 2.0 16V, 2.0 ECOTEC		<b>F8-6691</b>	⊕	
Engine Mounting	2.0 CDTI	M9R 780, M9R 784, M9R 786, M9R 788; not for  M9R630, M9R692	<b>F8-6691</b>	⊕	
Engine Mounting	2.0 CDTI	M9R 780; not for  M9R630, M9R692	<b>F8-6691</b>	⊕	
Engine Mounting	1.9 DI, 1.9 DTI, 2.0 16V, 2.0 ECOTEC		<b>F8-6692</b>	⬆	
Engine Mounting	1.9 DI, 1.9 DTI, 2.0 16V, 2.0 ECOTEC		<b>F8-6693</b>	⬇	
Anti-Friction Bearing	1.9 DI, 1.9 DTI, 2.0 16V, 2.5 CDTI, 2.5 DTI		<b>F8-7151</b>		H1=15; H2=12; d=16; D=52
Belt Pulley, crankshaft	1.9 DI	F9Q 762; Number of Ribs: 4; Parameter: 5PK;	<b>F8-7652</b>		Belt Pulley Ø [mm]=151; H1=25
Belt Pulley, crankshaft	1.9 DTI	F9Q 760; Number of Ribs: 4; Parameter: 5PK;	<b>F8-7652</b>		Belt Pulley Ø [mm]=151; H1=25
Engine Mounting	2.0 CDTI, 2.5 CDTI, 2.5 DTI		<b>F8-7733</b>	⊕	
Engine Mounting	2.0 CDTI, 2.5 CDTI, 2.5 DTI		<b>F8-7736</b>	⬇	

<b>F5-1025</b>	<b>F5-1036</b>	<b>F5-1110</b>	<b>F8-6196</b>	<b>F8-6197</b>	<b>F8-6478</b>	<b>F8-6661</b>
Ref.Nr.: 23151-00Q0B	Ref.Nr.: 23151-00Q0A	Ref.Nr.: 8200489514	Ref.Nr.: 54320-00QAA	Ref.Nr.: 7701207491SK	Ref.Nr.: 48203-00QAE	Ref.Nr.: 4412907
<b>F8-6690</b>	<b>F8-6691</b>	<b>F8-6692</b>	<b>F8-6693</b>	<b>F8-7151</b>	<b>F8-7652</b>	<b>F8-7733</b>
Ref.Nr.: 11323-00QAA	Ref.Nr.: 11246-00QAB	Ref.Nr.: 11356-00QAA	Ref.Nr.: 11238-00QAA	Ref.Nr.: 4408056	Ref.Nr.: 93161258	Ref.Nr.: 11323-00QAB
<b>F8-7736</b>	<b>F8-7737</b>	<b>F8-7988</b>				
Ref.Nr.: 4411938	Ref.Nr.: 93853920	Ref.Nr.: 8200002869				

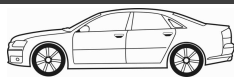
**Article Description****Article Nr.****Fitting Position**

<b>VIVARO Box (F7)</b>				<b>08/2001 →</b>	
Engine Mounting	2.0 CDTI		<b>F8-7737</b>		
Control Arm-/Trailing Arm Bush	1.9 Di, 1.9 DTI, 2.0 16V, 2.0 ECOTEC, 2.5 DTI		<b>F8-7988</b>		
Control Arm-/Trailing Arm Bush	2.0 CDTI	M9R 780	<b>F8-7988</b>		
Control Arm-/Trailing Arm Bush	2.0 CDTI	M9R 782	<b>F8-7988</b>		
Control Arm-/Trailing Arm Bush	2.5 CDTI	G9U 630	<b>F8-7988</b>		
<b>VIVARO Platform/Chassis (E7)</b>				<b>01/2006 →</b>	
Alternator Freewheel Clutch	1.9 Di, 1.9 DTI, 2.0 16V, 2.0 ECOTEC, 2.5 CDTI, 2.5 DTI		<b>F5-1025</b>		
Alternator Freewheel Clutch	1.9 Di, 1.9 DTI, 2.0 16V, 2.0 ECOTEC		<b>F5-1036</b>		
Alternator Freewheel Clutch	2.0 CDTI		<b>F5-1110</b>		
Top Strut Mounting	1.9 DTI, 2.0 16V, 2.0 CDTI, 2.0 ECOTEC, 2.5 CDTI		<b>F8-6196</b>		
Top Strut Mounting	1.9 DTI, 2.0 16V, 2.0 CDTI, 2.0 ECOTEC, 2.5 CDTI		<b>F8-6197</b>		
Bellow Set, steering	2.0 CDTI, 2.0 ECOTEC, 2.5 CDTI	with clamps	<b>F8-6478</b>		d1=13; d2=54,5; L [mm]=215
Mounting, axle beam	2.0 CDTI, 2.0 ECOTEC, 2.5 CDTI		<b>F8-6661</b>		
Engine Mounting	1.9 Di, 1.9 DTI, 2.0 16V, 2.0 ECOTEC		<b>F8-6690</b>		
Engine Mounting	1.9 Di, 1.9 DTI, 2.0 16V, 2.0 ECOTEC		<b>F8-6691</b>		
Engine Mounting	2.0 CDTI	not for  M9R630, M9R692	<b>F8-6691</b>		
Engine Mounting	1.9 Di, 1.9 DTI, 2.0 16V, 2.0 ECOTEC		<b>F8-6692</b>		
Engine Mounting	1.9 Di, 1.9 DTI, 2.0 16V, 2.0 ECOTEC		<b>F8-6693</b>		
Anti-Friction Bearing	2.5 CDTI		<b>F8-7151</b>		H1=15; H2=12; d=16; D=52
Belt Pulley, crankshaft	1.9 DTI	F9Q 760; Number of Ribs: 4; Parameter: 5PK;	<b>F8-7652</b>		Belt Pulley Ø [mm]=151; H1=25
Engine Mounting	2.0 CDTI, 2.5 CDTI, 2.5 DTI		<b>F8-7733</b>		
Engine Mounting	2.0 CDTI, 2.5 CDTI, 2.5 DTI		<b>F8-7736</b>		
Engine Mounting	2.0 CDTI		<b>F8-7737</b>		
Control Arm-/Trailing Arm Bush	1.9 DTI, 2.0 16V, 2.0 CDTI, 2.0 ECOTEC, 2.5 CDTI, 2.5 DTI		<b>F8-7988</b>		
<b>ZAFIRA A (F75_)</b>				<b>04/1999 → 06/2005</b>	
Rubber Buffer, suspension	1.6 16V, 1.6 CNG, 1.8 16V, 2.0 Di 16V, 2.0 DTI 16V, 2.2 16V, 2.2 DTI 16V		<b>AK-735038</b>		
Alternator Freewheel Clutch	1.6, 1.6 16V, 1.6 CNG, 1.8, 1.8 16V		<b>F5-1050</b>		
Alternator Freewheel Clutch	2.0 OPC		<b>F5-1100</b>		
Control Arm-/Trailing Arm Bush	1.6 16V, 1.6 CNG, 1.8 16V, 2.0 Di 16V, 2.0 DTI 16V, 2.0 OPC, 2.2 16V		<b>F8-4090</b>		H1=50; H2=59; d=12; D1=36; D2=43

<b>AK-735038</b>	<b>F5-1025</b>	<b>F5-1036</b>	<b>F5-1050</b>	<b>F5-1100</b>	<b>F5-1110</b>	<b>F8-4090</b>
Ref.Nr.: 344417	Ref.Nr.: 23151-00Q0B	Ref.Nr.: 23151-00Q0A	Ref.Nr.: 1204412	Ref.Nr.: 1204393	Ref.Nr.: 8200489514	Ref.Nr.: 4566899
<b>F8-5130</b>	<b>F8-6196</b>	<b>F8-6197</b>	<b>F8-6478</b>	<b>F8-6661</b>	<b>F8-6690</b>	<b>F8-6691</b>
Ref.Nr.: 352365	Ref.Nr.: 54320-00QAA	Ref.Nr.: 7701207491SK	Ref.Nr.: 48203-00QAE	Ref.Nr.: 4412907	Ref.Nr.: 11323-00QAA	Ref.Nr.: 11246-00QAB
<b>F8-6692</b>	<b>F8-6693</b>	<b>F8-7151</b>	<b>F8-7652</b>	<b>F8-7733</b>	<b>F8-7736</b>	<b>F8-7737</b>
Ref.Nr.: 11356-00QAA	Ref.Nr.: 11238-00QAA	Ref.Nr.: 4408056	Ref.Nr.: 93161258	Ref.Nr.: 11323-00QAB	Ref.Nr.: 4411938	Ref.Nr.: 93853920

Article Description



Article Nr.

Fitting Position



ZAFIRA A (F75)		04/1999 → 06/2005	
Control Arm-/Trailing Arm Bush	1.6 16V, 1.6 CNG, 1.8 16V, 2.0 DI 16V, 2.0 DTI 16V, 2.0 OPC, 2.2 16V	F8-5130	H=60; d=12; D=47
Engine Mounting	1.6 16V, 1.8 16V	Code: KZ YU;	F8-5365
Top Strut Mounting	1.6, 1.6 16V, 1.6 CNG, 1.8, 1.8 16V, 2.0 DI 16V, 2.0 DTI 16V, 2.0 OPC, 2.2 16V, 2.2 DTI 16V	Bearing Type: Soft Version;	F8-5448
Top Strut Mounting	1.6, 1.6 16V, 1.6 CNG, 1.8, 1.8 16V, 2.0 DI 16V, 2.0 DTI 16V, 2.0 OPC, 2.2 16V, 2.2 DTI 16V	;	F8-5463
Belt Pulley, crankshaft	2.0 DI 16V, 2.0 DTI 16V		F8-5639
Belt Pulley, crankshaft	2.2 DTI 16V	09/2002 →	F8-5639
Rubber Buffer, suspension	1.6 16V, 1.6 CNG, 1.8, 1.8 16V, 2.0 DI 16V, 2.0 DTI 16V, 2.0 OPC, 2.2 16V, 2.2 DTI 16V		F8-5878  H=62.5; d=24; D=50
Rubber Buffer, suspension	1.6 16V, 1.6 CNG, 1.8, 1.8 16V, 2.0 DI 16V, 2.0 DTI 16V, 2.0 OPC, 2.2 16V, 2.2 DTI 16V		F8-5913  H=53; d=19; D=50
Engine Mounting	2.0 DI 16V, 2.0 DTI 16V		F8-6494
Rubber Buffer, suspension	1.6, 1.6 16V, 1.6 CNG, 1.8, 1.8 16V, 2.0 DI 16V, 2.0 DTI 16V, 2.0 OPC, 2.2 16V, 2.2 DTI 16V		F8-6517
Mounting, axle beam	1.6 16V, 1.6 CNG, 1.8, 1.8 16V, 2.0 DI 16V, 2.0 DTI 16V, 2.0 OPC, 2.2 16V, 2.2 DTI 16V		F8-6733  d=14; L=35; D1=46; D2=38.4
Mounting, axle beam	1.6 16V, 1.6 CNG, 1.8, 1.8 16V, 2.0 DI 16V, 2.0 DTI 16V, 2.0 OPC, 2.2 16V, 2.2 DTI 16V		F8-6734  H=35.2; d=14.2; D1=45.9; D2=35.2
Engine Mounting	1.6 16V, 1.8 16V	Yellow;	F8-6755
Engine Mounting	1.6 16V, 1.6 CNG, 1.8, 1.8 16V		F8-6835
Engine Mounting	2.0 DTI 16V	ch.32000001, 35000001, 36000001, 38000001, 3B000001, 3H000001, 4G000001→	F8-6836
Engine Mounting	2.0 OPC	Manufacturer Restriction: Code:HP;	F8-6944
Engine Mounting	2.2 16V		F8-6974
Spring Cap	1.6, 1.6 16V, 1.6 CNG, 1.8, 1.8 16V, 2.0 DI 16V, 2.0 DTI 16V, 2.0 OPC, 2.2 16V, 2.2 DTI 16V		F8-7372
Mounting, axle beam	All Models		F8-7913
Stabiliser Mounting	All Models	ch.→Y2168371	F8-7945  d=22
Engine Mounting	1.6 16V, 1.8, 1.8 16V		F8-8071
Repair Kit, suspension strut	1.6, 1.6 16V, 1.6 CNG, 1.8, 1.8 16V, 2.0 DI 16V, 2.0 DTI 16V, 2.0 OPC, 2.2 16V, 2.2 DTI 16V		F8-8085
Engine Mounting	1.6 16V, 1.6 CNG, 1.8 16V, 2.0 DI 16V, 2.0 DTI 16V, 2.0 OPC, 2.2 16V, 2.2 DTI 16V		F8-8137
Engine Mounting	1.6 CNG		F8-8142
Engine Mounting	2.0 DI 16V		F8-8155
Engine Mounting	1.6 16V, 1.6 CNG, 1.8 16V		F8-8195
Repair Kit, suspension strut	1.6 16V, 1.6 CNG, 1.8, 1.8 16V, 2.0 DI 16V, 2.0 DTI 16V, 2.0 OPC, 2.2 16V, 2.2 DTI 16V	Bearing Type: Hard Version;	F8-8214

<b>F8-5130</b>	<b>F8-5365</b>	<b>F8-5448</b>	<b>F8-5463</b>	<b>F8-5639</b>	<b>F8-5878</b>	<b>F8-5913</b>
Ref.Nr.: 352365	Ref.Nr.: 5684045	Ref.Nr.: 0344523	Ref.Nr.: 0344525	Ref.Nr.: 0614411	Ref.Nr.: 0344417	Ref.Nr.: 0344421
<b>F8-6494</b>	<b>F8-6517</b>	<b>F8-6733</b>	<b>F8-6734</b>	<b>F8-6755</b>	<b>F8-6835</b>	<b>F8-6836</b>
Ref.Nr.: 0 684 697	Ref.Nr.: 90468618	Ref.Nr.: 13107328	Ref.Nr.: 302275	Ref.Nr.: 90575457	Ref.Nr.: 684694	Ref.Nr.: 24427298
<b>F8-6944</b>	<b>F8-6974</b>	<b>F8-7372</b>	<b>F8-7913</b>	<b>F8-7945</b>	<b>F8-8071</b>	<b>F8-8085</b>
Ref.Nr.: 13115706	Ref.Nr.: 684249	Ref.Nr.: 0344591	Ref.Nr.: 5402638	Ref.Nr.: 350093	Ref.Nr.: 684693	Ref.Nr.: 344523

**Article Description****Article Nr.****Fitting Position**

<b>ZAFIRA A (F75_)</b>			<b>04/1999 → 06/2005</b>	
Bellow, steering	2.0 OPC	for steering gear manufacturer: Delphi; with clamps	<b>LM-10041S</b>	d1=13; d2=53; L [mm]=200
<b>ZAFIRA B (A05)</b>			<b>07/2005 →</b>	
Dust Cover Kit, shock absorber	1.6, 1.6 CNG, 1.6 CNG Turbo, 1.7 CDTI, 1.8, 1.9 CDTI, 2.0, 2.2		<b>AK-735251</b>	⊕ ⊕
Dust Cover Kit, shock absorber	1.6, 1.6 CNG, 1.7 CDTI, 1.8, 1.9 CDTI, 2.0, 2.2	<b>ST</b>	<b>AK-735252</b>	⊕ ⊕
Dust Cover Kit, shock absorber	1.7 CDTI, 1.8, 1.9 CDTI, 2.0, 2.2	<b>SP</b>	<b>AK-735252</b>	⊕ ⊕
Alternator Freewheel Clutch	1.7 CDTI		<b>F5-1049</b>	
Alternator Freewheel Clutch	1.6, 1.6 CNG		<b>F5-1050</b>	
Alternator Freewheel Clutch	2.2		<b>F5-1079</b>	
Alternator Freewheel Clutch	2.0		<b>F5-1100</b>	
Alternator Freewheel Clutch	1.9 CDTI		<b>F5-1102</b>	
Alternator Freewheel Clutch	1.9 CDTI		<b>F5-1123</b>	
Mounting, axle beam	1.6, 1.6 CNG, 1.7 CDTI, 1.8, 1.9 CDTI, 2.0, 2.2		<b>F8-6733</b>	⊕ ⊕ d=14; L=35; D1=46; D2=38.4
Mounting, axle beam	1.6, 1.6 CNG, 1.7 CDTI, 1.8, 1.9 CDTI, 2.0, 2.2		<b>F8-6734</b>	⊕ ⊕ H=35.2; d=14.2; D1=45.9; D2=35.2
Engine Mounting	1.7 CDTI		<b>F8-6836</b>	⊕
Engine Mounting	1.7 CDTI	ch.32000001, 35000001, 36000001, 38000001, 3B000001, 3H000001, 4G000001→	<b>F8-6836</b>	⊕
Engine Mounting	1.9 CDTI		<b>F8-6836</b>	⊕
Engine Mounting	1.6, 1.6 CNG	Code: KZ JE	<b>F8-6975</b>	
Engine Mounting	1.8	Code: KZ JE;  Z 18 XER	<b>F8-6975</b>	
Engine Mounting	2.0		<b>F8-6977</b>	
Engine Mounting	2.2		<b>F8-6977</b>	
Engine Mounting	1.9 CDTI		<b>F8-6979</b>	
Engine Mounting	1.6, 1.6 CNG, 1.8	Code: KZ KD	<b>F8-6980</b>	⊕
Engine Mounting	1.6		<b>F8-6981</b>	⊕
Engine Mounting	2.0		<b>F8-6983</b>	⊕
Engine Mounting	2.2		<b>F8-6983</b>	⊕
Engine Mounting	1.7 CDTI	Code: KZ KA;  Z 17 DTJ;	<b>F8-6984</b>	⊕
Engine Mounting	1.9 CDTI	Code: KZ KA;	<b>F8-6984</b>	⊕
Engine Mounting	2.2	Code: KZ KA;	<b>F8-6984</b>	⊕
Engine Mounting	1.9 CDTI	Code: KB;	<b>F8-6985</b>	⊕
Anti-Friction Bearing	1.6, 1.6 CNG, 1.6 CNG Turbo, 1.7 CDTI, 1.8, 1.9 CDTI, 2.0, 2.2		<b>F8-7172</b>	⊕ ⊕
Top Strut Mounting	1.6, 1.6 CNG, 1.6 CNG Turbo, 1.7 CDTI, 1.8, 1.9 CDTI, 2.0, 2.2	Additionally required articles: F8-7625;	<b>F8-7327</b>	⊕ ⊕

<b>AK-735251</b>	<b>AK-735252</b>	<b>F5-1049</b>	<b>F5-1050</b>	<b>F5-1079</b>	<b>F5-1100</b>	<b>F5-1102</b>
Ref.Nr.: 344435	Ref.Nr.: 344416	Ref.Nr.: 1204366	Ref.Nr.: 1204412	Ref.Nr.: 1204376	Ref.Nr.: 1204393	Ref.Nr.: 1204151
<b>F5-1123</b>	<b>F8-6733</b>	<b>F8-6734</b>	<b>F8-6836</b>	<b>F8-6975</b>	<b>F8-6977</b>	<b>F8-6979</b>
Ref.Nr.: 9948513	Ref.Nr.: 13107328	Ref.Nr.: 302275	Ref.Nr.: 24427298	Ref.Nr.: 24459803	Ref.Nr.: 24459797	Ref.Nr.: 5684179
<b>F8-6980</b>	<b>F8-6981</b>	<b>F8-6983</b>	<b>F8-6984</b>	<b>F8-6985</b>	<b>F8-7172</b>	<b>F8-7327</b>
Ref.Nr.: 13125637	Ref.Nr.: 13159994	Ref.Nr.: 13159996	Ref.Nr.: 13159997	Ref.Nr.: 13159998	Ref.Nr.: 9191181	Ref.Nr.: 13186960

**Article Description**

**Article Nr.**
**Fitting Position**

<b>ZAFIRA B (A05)</b>			<b>07/2005 →</b>		
Top Strut Mounting	1.6, 1.6 CNG, 1.6 CNG Turbo, 1.7 CDTI, 1.8, 1.9 CDTI, 2.0, 2.2		<b>F8-7328</b>		
Top Strut Mounting	1.6, 1.6 CNG, 1.6 CNG Turbo, 1.7 CDTI, 1.8, 1.9 CDTI, 2.0, 2.2		<b>F8-7328S</b>		
Mounting Kit, shock absorber	1.6, 1.6 CNG, 1.6 CNG Turbo, 1.7 CDTI, 1.8, 1.9 CDTI, 2.0, 2.2	for article nr: A-3246GL & A-3246GR, F8-7327	<b>F8-7625</b>		
Rubber Buffer, suspension	1.6, 1.6 CNG, 1.6 CNG Turbo, 1.7 CDTI, 1.8, 1.9 CDTI, 2.0, 2.2		<b>F8-7662</b>		H=40
Protective Cap/Bellow, shock absorber	1.6, 1.6 CNG, 1.6 CNG Turbo, 1.7 CDTI, 1.8, 1.9 CDTI, 2.0, 2.2		<b>F8-7663</b>		H=205
Rubber Buffer, suspension	1.6, 1.6 CNG, 1.6 CNG Turbo, 1.7 CDTI, 1.8, 1.9 CDTI, 2.0, 2.2		<b>F8-7699</b>		H=50
Belt Pulley, crankshaft	1.7 CDTI	Number of Ribs: 5; Parameter: 6PK	<b>F8-7872</b>		Belt Pulley Ø [mm]=149; H1=22; H2=32
Mounting, axle beam	1.6, 1.6 CNG, 1.7 CDTI, 1.9 CDTI, 2.0, 2.2		<b>F8-7944</b>		d=13
Mounting, axle beam	1.8		<b>F8-7944</b>		d=13
Control Arm-/Trailing Arm Bush	1.6, 1.6 CNG, 1.6 CNG Turbo, 1.7 CDTI, 1.8, 1.9 CDTI, 2.0, 2.2		<b>F8-7946</b>		
Engine Mounting	1.6, 1.6 CNG, 1.6 CNG Turbo, 1.7 CDTI, 1.8, 1.9 CDTI, 2.0, 2.2		<b>F8-8137</b>		
Engine Mounting	1.6		<b>F8-8142</b>		
<b>ZAFIRA B Van</b>			<b>07/2005 →</b>		
Alternator Freewheel Clutch	1.7 CDTI		<b>F5-1049</b>		
Mounting Kit, shock absorber	All Models	for article nr: A-3246GL & A-3246GR, F8-7327	<b>F8-7625</b>		

<b>F5-1049</b>	<b>F8-7328</b>	<b>F8-7328S</b>	<b>F8-7625</b>	<b>F8-7662</b>	<b>F8-7663</b>	<b>F8-7699</b>
Ref.Nr.: 1204366	Ref.Nr.: 13270705	Ref.Nr.: 344625	Ref.Nr.: 24402155	Ref.Nr.: 0344956	Ref.Nr.: 344435	Ref.Nr.: 13117280
<b>F8-7872</b>	<b>F8-7944</b>	<b>F8-7946</b>	<b>F8-8137</b>	<b>F8-8142</b>		
Ref.Nr.: 614758	Ref.Nr.: 402 952	Ref.Nr.: 352324	Ref.Nr.: 682502	Ref.Nr.: 90538582		

**Article Description****Article Nr.****Fitting Position**

			<b>10/1972 → 06/1988</b>	
Dust Cover Kit, shock absorber	1.4	ch.5852872→; 01/1980 →	<b>AK-735010</b>	
Engine Mounting	0.9, 1.0, 1.1, 1.2, 1.4		<b>F8-6854</b>	
Engine Mounting	0.9, 1.1	08/1979 →	<b>F8-6854</b>	
Control Arm-/Trailing Arm Bush	0.9, 1.1, 1.2, 1.4		<b>G9-521</b>	H1=24; H2=42; d=14; D1=21; D2=38
			<b>09/1973 → 06/1988</b>	
Dust Cover Kit, shock absorber	1.1		<b>AK-735010</b>	
Dust Cover Kit, shock absorber	1.4	ch.5684068→	<b>AK-735010</b>	
Engine Mounting	0.9, 1.1	08/1979 →	<b>F8-6854</b>	
Engine Mounting	1.1, 1.4		<b>F8-6854</b>	
Control Arm-/Trailing Arm Bush	0.9, 1.1, 1.4		<b>G9-521</b>	H1=24; H2=42; d=14; D1=21; D2=38
			<b>08/1991 → 04/1996</b>	
Dust Cover Kit, shock absorber	1.0, 1.1, 1.4, 1.4 D, 1.5 D, 1.6		<b>AK-735010</b>	
Anti-Friction Bearing	All Models		<b>F8-3012</b>	H=20; d=66; D=100
Control Arm-/Trailing Arm Bush	1.0, 1.1, 1.3, 1.4, 1.4 D, 1.5 D, 1.6		<b>F8-5251</b>	
Bellow, driveshaft	1.4, 1.4 D, 1.5 D		<b>F8-5356</b>	D1=72; D219; L=172
Engine Mounting	1.4	Grey Cast Iron	<b>F8-5358</b>	
Engine Mounting	1.5 D, 1.6		<b>F8-5358</b>	
Top Strut Mounting	1.0, 1.1, 1.3, 1.4, 1.4 D, 1.5 D, 1.6	ch.50265609→;	<b>F8-5518</b>	
Top Strut Mounting	1.0, 1.4, 1.5 D		<b>F8-5518</b>	
Top Strut Mounting	1.0, 1.1, 1.3, 1.4, 1.4 D, 1.5 D, 1.6	ch.→50265608;	<b>F8-5519</b>	
Top Strut Mounting	1.0, 1.4		<b>F8-5519</b>	
Engine Mounting	1.0, 1.1, 1.3, 1.4, 1.4 D, 1.6		<b>F8-5556</b>	
Belt Pulley, crankshaft	1.5 D		<b>F8-5644</b>	
Mounting, axle beam	1.0, 1.1, 1.3, 1.4, 1.4 D, 1.5 D, 1.6		<b>F8-5799</b>	H=47; d=12; D=32
Mounting, axle beam	1.4		<b>F8-5799</b>	H=47; d=12; D=32
Stabiliser Mounting	1.0, 1.1, 1.3, 1.4, 1.4 D, 1.5 D, 1.6	Orga.O 04803→; Stabi. Diam. [mm]= 19	<b>F8-6096</b>	d=19
Control Arm-/Trailing Arm Bush	1.3, 1.4, 1.6		<b>F8-6143</b>	
Repair Kit, wheel suspension	1.0, 1.1, 1.3, 1.4, 1.4 D, 1.5 D, 1.6		<b>F8-6274</b>	
Repair Kit, wheel suspension	1.0, 1.1, 1.3, 1.4, 1.4 D, 1.5 D, 1.6		<b>F8-6275</b>	
Top Strut Mounting	1.0, 1.1, 1.4		<b>F8-6292</b>	
Top Strut Mounting	1.0, 1.1, 1.4	08/1992 →;	<b>F8-6293</b>	
Top Strut Mounting	1.3, 1.4 D, 1.5 D, 1.6		<b>F8-6293</b>	

<b>AK-735010</b>	<b>F8-3012</b>	<b>F8-5251</b>	<b>F8-5356</b>	<b>F8-5358</b>	<b>F8-5518</b>	<b>F8-5519</b>
Ref.Nr.:	Ref.Nr.: 503527	Ref.Nr.: 352364	Ref.Nr.: 328769	Ref.Nr.: 184373	Ref.Nr.: 503815	Ref.Nr.: 5038.52
<b>F8-5556</b>	<b>F8-5644</b>	<b>F8-5799</b>	<b>F8-6096</b>	<b>F8-6143</b>	<b>F8-6274</b>	<b>F8-6275</b>
Ref.Nr.: 1843.95	Ref.Nr.: 0515L6	Ref.Nr.: 5131.63	Ref.Nr.: 5094.59	Ref.Nr.: 96148480	Ref.Nr.: 5133.22	Ref.Nr.: 5174.07
<b>F8-6292</b>	<b>F8-6293</b>	<b>F8-6487</b>	<b>F8-6854</b>	<b>G9-521</b>		
Ref.Nr.: 503527	Ref.Nr.: 503527	Ref.Nr.: 184472	Ref.Nr.: 1807.45	Ref.Nr.: 91504248		

Article Description

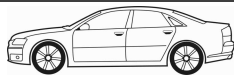

Article Nr.

Fitting Position



<b>106 (1A, 1C)</b>				<b>08/1991 → 04/1996</b>	
Engine Mounting	1.3, 1.4, 1.4 D		<b>F8-6487</b>	⊕	
Mounting, automatic transmission	1.4 D, 1.5 D		<b>F8-6505</b>	⊕	
Mounting, automatic transmission	1.6		<b>F8-6505</b>	⊕	
Engine Mounting	1.4	08/1995 →; Aluminium	<b>F8-6898</b>	⊕	
Engine Mounting	1.4, 1.4 D	08/1995 →	<b>F8-6898</b>	⊕	
Engine Mounting	1.0	08/1995 →	<b>F8-6904</b>		
Engine Mounting	1.1, 1.3, 1.4 D, 1.5 D		<b>F8-6904</b>		
Engine Mounting	1.4	Aluminium, Cast Steel;  TU3M	<b>F8-6904</b>		
Engine Mounting	1.6		<b>F8-6904</b>		
Bearing, drive shaft	1.6		<b>F8-7173</b>		d=25.8
Belt Pulley, crankshaft	1.6	Number of Ribs: 4; Parameter: 5PK;	<b>F8-7643</b>		D=128
Engine Mounting	1.0, 1.1		<b>F8-8199</b>	⊕	
Repair Kit, wheel suspension	1.0, 1.1, 1.3, 1.4, 1.4 D, 1.5 D, 1.6		<b>G8-274</b>		
Repair Kit, wheel suspension	1.0, 1.1, 1.3, 1.4, 1.4 D, 1.5 D, 1.6		<b>G8-275</b>		
Control Arm-/Trailing Arm Bush	1.0, 1.1, 1.3, 1.4, 1.4 D, 1.5 D, 1.6		<b>G9-555</b>	⊕ ⊕	H=46; d=17; W=55, 85
Control Arm-/Trailing Arm Bush	1.0, 1.1, 1.3, 1.4, 1.4 D, 1.5 D, 1.6		<b>G9-556</b>	⊕ ⊕ ⊕	H1=30; H2=49; d=12; D=34
Bellow, steering	1.0, 1.1, 1.3, 1.4, 1.4 D, 1.5 D, 1.6		<b>LM-10014S</b>		d1=12; d2=40; L [mm]=106
Bellow, steering	1.0, 1.1, 1.3, 1.4, 1.4 D, 1.5 D, 1.6	with adapter, with clamps	<b>LM-10051S</b>		H=20; d=38; d1=17; d2=22; L [mm]=134
<b>106 Van (1_)</b>				<b>09/1991 → 07/2004</b>	
Anti-Friction Bearing	1.5 D		<b>F8-3012</b>	⊕ ⊕	H=20; d=66; D=100
Repair Kit, wheel suspension	All Models		<b>F8-6274</b>		
Repair Kit, wheel suspension	All Models		<b>F8-6275</b>		
Repair Kit, wheel suspension	All Models		<b>G8-274</b>		
Repair Kit, wheel suspension	All Models		<b>G8-275</b>		
<b>106 Mk II (1)</b>				<b>04/1996 → 07/2004</b>	
Dust Cover Kit, shock absorber	1.0 i, 1.1 i, 1.4 i, 1.5 D, 1.6 i, 1.6 S16		<b>AK-735010</b>	⊕ ⊕	
Anti-Friction Bearing	All Models		<b>F8-3012</b>	⊕ ⊕	H=20; d=66; D=100
Control Arm-/Trailing Arm Bush	1.0 i, 1.1 i, 1.4 i, 1.5 D, 1.6 i, 1.6 S16		<b>F8-5251</b>	⊕ ⊕	
Bellow, driveshaft	1.6 i, 1.6 S16		<b>F8-5356</b>	⊕ ⊕	D1=72; D219; L=172
Top Strut Mounting	1.0 i, 1.1 i, 1.4 i, 1.5 D, 1.6 i, 1.6 S16	ch.50265609 →;	<b>F8-5518</b>	⊕ ⊕	
Top Strut Mounting	1.0 i, 1.5 D		<b>F8-5518</b>	⊕ ⊕	

<b>AK-735010</b>	<b>F8-3012</b>	<b>F8-5251</b>	<b>F8-5356</b>	<b>F8-5518</b>	<b>F8-5519</b>	<b>F8-6274</b>
Ref.Nr.: <b>503527</b>	Ref.Nr.: <b>352364</b>	Ref.Nr.: <b>328769</b>	Ref.Nr.: <b>503815</b>	Ref.Nr.: <b>5038.52</b>	Ref.Nr.: <b>5133.22</b>	
<b>F8-6275</b>	<b>F8-6487</b>	<b>F8-6505</b>	<b>F8-6898</b>	<b>F8-6904</b>	<b>F8-7173</b>	<b>F8-7643</b>
Ref.Nr.: <b>5174.07</b>	Ref.Nr.: <b>184472</b>	Ref.Nr.: <b>1844.51</b>	Ref.Nr.: <b>1844.58</b>	Ref.Nr.: <b>1844.54</b>	Ref.Nr.: <b>7664079</b>	Ref.Nr.: <b>0515.J3</b>
<b>F8-8199</b>	<b>G8-274</b>	<b>G8-275</b>	<b>G9-555</b>	<b>G9-556</b>	<b>LM-10014S</b>	<b>LM-10051S</b>
Ref.Nr.: <b>184399</b>	Ref.Nr.: <b>514858</b>	Ref.Nr.: <b>5174.05</b>	Ref.Nr.: <b>3523.51</b>	Ref.Nr.: <b>95603308</b>	Ref.Nr.: <b>4066.32</b>	Ref.Nr.: <b>4066.34</b>

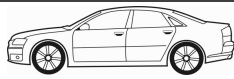

**Article Description****Article Nr.****Fitting Position**

<b>106 Mk II (1)</b>			<b>04/1996 → 07/2004</b>	
Top Strut Mounting	1.0 i, 1.1 i, 1.4 i, 1.5 D, 1.6 i, 1.6 S16	ch.→50265608;	<b>F8-5519</b>	⊕ ⊕
Engine Mounting	1.1 i, 1.4 i, 1.6 i, 1.6 S16		<b>F8-5556</b>	⊕
Belt Pulley, crankshaft	1.5 D		<b>F8-5644</b>	
Mounting, axle beam	1.0 i, 1.1 i, 1.4 i, 1.5 D, 1.6 i, 1.6 S16		<b>F8-5799</b>	⊕ ⊕ H=47; d=12; D=32
Mounting, axle beam	Electric		<b>F8-5799</b>	⊕ ⊕ H=47; d=12; D=32
Stabiliser Mounting	All Models	Orga.O 04803→; Stabi. Diam. [mm]= 19	<b>F8-6096</b>	d=19
Control Arm-/Trailing Arm Bush	1.1 i, 1.4 i, 1.6 i, 1.6 S16		<b>F8-6143</b>	⊕ ⊕
Repair Kit, wheel suspension	All Models		<b>F8-6274</b>	
Repair Kit, wheel suspension	All Models		<b>F8-6275</b>	
Top Strut Mounting	1.0 i, 1.1 i, 1.4 i, 1.5 D, 1.6 i, 1.6 S16		<b>F8-6293</b>	
Mounting, automatic transmission	1.0 i, 1.1 i, 1.4 i, 1.5 D, 1.6 i, 1.6 S16		<b>F8-6505</b>	⊕
Mounting, automatic transmission	1.1 i	TU1JP	<b>F8-6505</b>	⊕
Engine Mounting	1.4 i		<b>F8-6898</b>	⊕
Engine Mounting	1.0 i, 1.1 i, 1.5 D, 1.6 S16		<b>F8-6904</b>	
Engine Mounting	1.4 i, 1.6 i		<b>F8-6904</b>	
Bearing, drive shaft	1.4 i, 1.6 i		<b>F8-7173</b>	d=25.8
Belt Pulley, crankshaft	1.6 i	Number of Ribs: 4; Parameter: 5PK;	<b>F8-7643</b>	D=128
Belt Pulley, crankshaft	1.6 S16	Number of Ribs: 4; Parameter: 5PK;	<b>F8-7643</b>	D=128
Engine Mounting	1.0 i, 1.1 i		<b>F8-8199</b>	⊕
Repair Kit, wheel suspension	All Models		<b>G8-274</b>	
Repair Kit, wheel suspension	All Models		<b>G8-275</b>	
Control Arm-/Trailing Arm Bush	1.0 i, 1.1 i, 1.4 i, 1.5 D, 1.6 i, 1.6 S16		<b>G9-555</b>	⊕ ⊕ H=46; d=17; W=55, 85
Control Arm-/Trailing Arm Bush	1.0 i, 1.1 i, 1.4 i, 1.5 D, 1.6 i, 1.6 S16		<b>G9-556</b>	⊕ ⊕ ⊕ ↓ H1=30; H2=49; d=12; D=34
Bellow, steering	All Models		<b>LM-10014S</b>	d1=12; d2=40; L [mm]=106
Bellow, steering	1.0 i, 1.1 i, 1.4 i, 1.5 D, 1.6 i	with adapter, with clamps	<b>LM-10051S</b>	H=20; d=38; d1=17; d2=22; L [mm]=134
<b>107</b>			<b>06/2005 →</b>	
Dust Cover Kit, shock absorber	All Models		<b>AK-735416</b>	⊕ ⊕
Dust Cover Kit, shock absorber	All Models		<b>AK-735417</b>	⊕ ⊕
Alternator Freewheel Clutch	1.4 HDi		<b>F5-1048</b>	
Anti-Friction Bearing	All Models		<b>F8-6266</b>	
Control Arm-/Trailing Arm Bush	All Models		<b>F8-6587</b>	↓

<b>AK-735416</b>	<b>AK-735417</b>	<b>F5-1048</b>	<b>F8-5519</b>	<b>F8-5556</b>	<b>F8-5644</b>	<b>F8-5799</b>
Ref.Nr.: 503198	Ref.Nr.: 521034	Ref.Nr.: 77363468	Ref.Nr.: 5038.52	Ref.Nr.: 1843.95	Ref.Nr.: 0515L6	Ref.Nr.: 5131.63
<b>F8-6096</b>	<b>F8-6143</b>	<b>F8-6266</b>	<b>F8-6274</b>	<b>F8-6275</b>	<b>F8-6293</b>	<b>F8-6505</b>
Ref.Nr.: 5094.59	Ref.Nr.: 96148480	Ref.Nr.: 5035C2	Ref.Nr.: 5133.22	Ref.Nr.: 5174.07	Ref.Nr.: 503527	Ref.Nr.: 1844.51
<b>F8-6587</b>	<b>F8-6898</b>	<b>F8-6904</b>	<b>F8-7170</b>	<b>F8-7173</b>	<b>F8-7643</b>	<b>F8-8199</b>
Ref.Nr.: 48654-0H010	Ref.Nr.: 1844.58	Ref.Nr.: 1844.54	Ref.Nr.: 5038C1	Ref.Nr.: 7664079	Ref.Nr.: 0515.J3	Ref.Nr.: 184399

Article Description



Article Nr.

Fitting Position



107			06/2005 →		
Top Strut Mounting	All Models		F8-7170		
Top Strut Mounting	All Models		F8-7171		
205 (741A/C)			02/1983 → 10/1987		
Dust Cover Kit, shock absorber	1.0, 1.1, 1.3, 1.4, 1.5, 1.6, 1.6 GTI, 1.7 Diesel, 1.9 GTI		AK-735010		
Anti-Friction Bearing	1.0, 1.1, 1.3, 1.4, 1.5, 1.6, 1.6 GTI, 1.7 Diesel, 1.9 GTI		F8-3012		H=20; d=66; D=100
Engine Mounting	1.6, 1.6 GTI, 1.7 Diesel, 1.9 GTI		F8-5026		d=10; D=70; Thick. [mm]=40, 53
Control Arm-/Trailing Arm Bush	1.6 GTI, 1.9 GTI		F8-5072		d=12; D=42; W=38
Control Arm-/Trailing Arm Bush	1.0, 1.1, 1.3, 1.4, 1.5, 1.6, 1.7 Diesel		F8-5078		d=12; D=36; Thick. [mm]=25
Bellow, driveshaft	1.6		F8-5356		D1=72; D219; L=172
Bellow, driveshaft	1.6		F8-5356		D1=72; D219; L=172
Engine Mounting	1.6, 1.6 GTI, 1.7 Diesel, 1.9 GTI		F8-5358		
Engine Mounting	1.5, 1.6, 1.6 GTI, 1.7 Diesel, 1.9 GTI		F8-5375		H=34; d=12; D=30
Top Strut Mounting	1.0, 1.1, 1.3, 1.4, 1.5, 1.6, 1.6 GTI, 1.7 Diesel, 1.8 Rally, 1.9 GTI		F8-5520		
Engine Mounting	1.0, 1.1, 1.3, 1.4, 1.5, 1.6, 1.6 GTI, 1.7 Diesel, 1.9 GTI		F8-5555		
Engine Mounting	1.6, 1.6 GTI, 1.7 Diesel, 1.9 GTI		F8-5556		
Engine Mounting	1.0, 1.1, 1.4, 1.5, 1.6, 1.6 GTI, 1.7 Diesel, 1.8 Rally, 1.8 Rally 4x4, 1.9 GTI		F8-5558		
Mounting, axle beam	1.0, 1.1, 1.4, 1.5, 1.6, 1.6 GTI, 1.7 Diesel, 1.8 Rally, 1.8 Rally 4x4, 1.9 GTI		F8-5566		
Belt Pulley, crankshaft	1.7 Diesel		F8-5646		
Rubber Buffer, suspension	1.0, 1.1, 1.4, 1.6, 1.7 Diesel		F8-5798		L=57
Repair Set, axle beam	1.0, 1.1, 1.3, 1.4, 1.5, 1.6, 1.7 Diesel		F8-5855		H=34; D=30, 41
Rubber Buffer, suspension	1.0, 1.1, 1.4, 1.6, 1.7 Diesel		F8-6064		L=79
Repair Kit, wheel suspension	All Models		F8-6272		
Engine Mounting	1.0, 1.1, 1.4, 1.5, 1.6		F8-6487		
Stabiliser Mounting	1.0, 1.1, 1.3, 1.4, 1.5, 1.6, 1.6 GTI, 1.7 Diesel, 1.9 GTI	Stabi. Diam. [mm]= 20	F8-6793		d=18
Stabiliser Mounting	1.0, 1.1, 1.3, 1.4, 1.5, 1.6, 1.6 GTI, 1.7 Diesel, 1.9 GTI	Stabi. Diam. [mm]= 22	F8-6794		d=22
Stabiliser Mounting	1.0, 1.1, 1.3, 1.4, 1.5, 1.6, 1.6 GTI, 1.7 Diesel, 1.8 Rally, 1.9 GTI		F8-6795		D=23; d=22
Engine Mounting	1.0, 1.1, 1.3, 1.4		F8-6854		
Repair Kit, wheel suspension	All Models		G8-272		
Control Arm-/Trailing Arm Bush	1.0, 1.1, 1.3, 1.4, 1.5, 1.6, 1.7 Diesel		G9-520		H1=34; H2=28; d=10; D=28
Control Arm-/Trailing Arm Bush	1.0, 1.1, 1.3, 1.4, 1.5, 1.6, 1.7 Diesel		G9-523		H=25; d=12; D1=36; D2=47

<b>AK-735010</b>	<b>F8-3012</b>	<b>F8-5026</b>	<b>F8-5072</b>	<b>F8-5078</b>	<b>F8-5356</b>	<b>F8-5358</b>
Ref.Nr.:	Ref.Nr.: 503527	Ref.Nr.: 9606121080	Ref.Nr.: 3523.23	Ref.Nr.: 2523.29	Ref.Nr.: 328769	Ref.Nr.: 184373
<b>F8-5375</b>	<b>F8-5520</b>	<b>F8-5555</b>	<b>F8-5556</b>	<b>F8-5558</b>	<b>F8-5566</b>	<b>F8-5646</b>
Ref.Nr.: 180906	Ref.Nr.: 503518	Ref.Nr.: 97521102	Ref.Nr.: 1843.95	Ref.Nr.: 1843.97	Ref.Nr.: 515110	Ref.Nr.: 0515K9
<b>F8-5798</b>	<b>F8-5855</b>	<b>F8-6064</b>	<b>F8-6272</b>	<b>F8-6487</b>	<b>F8-6793</b>	<b>F8-6794</b>
Ref.Nr.: 5033.23	Ref.Nr.: 5131.43	Ref.Nr.: 5033.26	Ref.Nr.: 9556384280	Ref.Nr.: 184472	Ref.Nr.: 5094.36	Ref.Nr.: 5094.37

**Article Description****Article Nr.****Fitting Position**

<b>205 (741A/C)</b>			<b>02/1983 → 10/1987</b>		
Repair Kit, link	1.0, 1.1, 1.3, 1.4, 1.5, 1.6, 1.7 Diesel		<b>G9-523S</b>		H=25; d=12; D1=36; D2=47
Control Arm-/Trailing Arm Bush	1.0, 1.1, 1.4, 1.6, 1.6 GTI, 1.7 Diesel, 1.9 GTI		<b>G9-525</b>		H=34; d=10; D=28
Bellow, steering	1.0, 1.1, 1.3, 1.4, 1.5, 1.6, 1.6 GTI, 1.7 Diesel, 1.9 GTI	with clamps;	<b>LM-10004S</b>		d1=10; d2=40; L [mm]=175
Bellow, steering	1.0, 1.1, 1.3, 1.4, 1.5, 1.6, 1.6 GTI, 1.7 Diesel, 1.9 GTI	with clamps;	<b>LM-10004S</b>		d1=10; d2=40; L [mm]=175
Bellow, steering	1.0, 1.1, 1.4, 1.6, 1.7 Diesel, 1.9 GTI	with clamps;	<b>LM-10039S</b>		d1=40; d2=40; L [mm]=115
Bellow, steering	1.4	XY7; with clamps;	<b>LM-10039S</b>		d1=40; d2=40; L [mm]=115
Bellow, steering	1.5	G2S; with clamps;	<b>LM-10039S</b>		d1=40; d2=40; L [mm]=115
Bellow, steering	1.6 GTI	XU5J; with clamps;	<b>LM-10039S</b>		d1=40; d2=40; L [mm]=115
Bellow, steering	1.8 Rally, 1.8 Rally 4x4	XY10; with clamps;	<b>LM-10039S</b>		d1=40; d2=40; L [mm]=115
Bellow Set, drive shaft	1.4		<b>M-850850</b>		H=120; d1=28; d2=75.5
Bellow Set, drive shaft	1.4		<b>MK-850850</b>		
<b>205 Convertible (741B, 20D)</b>			<b>04/1986 → 12/1994</b>		
Dust Cover Kit, shock absorber	1.4 CT, 1.6 CTi, 1.9 CTi		<b>AK-735010</b>		
Anti-Friction Bearing	1.1 CJ, 1.4 CJ, 1.4 CJ CAT, 1.4 CT, 1.6 CJ, 1.6 CTi, 1.9 CTi		<b>F8-3012</b>		H=20; d=66; D=100
Control Arm-/Trailing Arm Bush	1.6 CTi, 1.9 CTi		<b>F8-5072</b>		d=12; D=42; W=38
Control Arm-/Trailing Arm Bush	1.1 CJ, 1.4 CJ, 1.4 CJ CAT, 1.4 CT, 1.6 CJ		<b>F8-5078</b>		d=12; D=36; Thick. [mm]=25
Bellow, driveshaft	1.4 CJ, 1.4 CJ CAT	Transmission Type: MA	<b>F8-5356</b>		D1=72; D219; L=172
Engine Mounting	1.9 CTi		<b>F8-5358</b>		
Engine Mounting	1.1, 1.1 CJ, 1.4, 1.4 CJ, 1.4 CJ CAT, 1.6 CJ, 1.9, 1.9 CTi		<b>F8-5375</b>		H=34; d=12; D=30
Top Strut Mounting	1.1 CJ, 1.4, 1.4 CJ, 1.4 CJ CAT, 1.4 CT, 1.6 CJ, 1.6 CTi, 1.9, 1.9 CTi		<b>F8-5520</b>		
Engine Mounting	1.1 CJ, 1.4 CJ, 1.4 CJ CAT, 1.6 CTi, 1.9 CTi		<b>F8-5556</b>		
Engine Mounting	1.1, 1.1 CJ, 1.4, 1.4 CJ, 1.4 CJ CAT, 1.4 CT, 1.6 CJ, 1.9, 1.9 CTi		<b>F8-5558</b>		
Engine Mounting	1.4 CJ	TU3M	<b>F8-5558</b>		
Mounting, axle beam	1.1, 1.1 CJ, 1.4, 1.4 CJ, 1.4 CJ CAT, 1.4 CT, 1.6 CJ, 1.9, 1.9 CTi		<b>F8-5566</b>		
Rubber Buffer, suspension	1.4 CJ, 1.4 CJ CAT, 1.4 CT		<b>F8-5798</b>		L=57
Repair Set, axle beam	1.1 CJ, 1.4 CJ, 1.4 CJ CAT, 1.4 CT, 1.6 CJ		<b>F8-5855</b>		H=34; D=30, 41
Rubber Buffer, suspension	1.1, 1.1 CJ, 1.4, 1.4 CJ, 1.4 CJ CAT, 1.4 CT, 1.6 CJ, 1.9, 1.9 CTi		<b>F8-6064</b>		L=79
Repair Kit, wheel suspension	All Models		<b>F8-6272</b>		
Engine Mounting	1.1, 1.1 CJ, 1.4, 1.4 CJ, 1.4 CJ CAT, 1.4 CT		<b>F8-6487</b>		

<b>AK-735010</b>	<b>F8-3012</b>	<b>F8-5072</b>	<b>F8-5078</b>	<b>F8-5356</b>	<b>F8-5358</b>	<b>F8-5375</b>
Ref.Nr.:	Ref.Nr.: 503527	Ref.Nr.: 3523.23	Ref.Nr.: 2523.29	Ref.Nr.: 328769	Ref.Nr.: 184373	Ref.Nr.: 180906
<b>F8-5520</b>	<b>F8-5556</b>	<b>F8-5558</b>	<b>F8-5566</b>	<b>F8-5798</b>	<b>F8-5855</b>	<b>F8-6064</b>
Ref.Nr.: 503518	Ref.Nr.: 1843.95	Ref.Nr.: 1843.97	Ref.Nr.: 515110	Ref.Nr.: 5033.23	Ref.Nr.: 5131.43	Ref.Nr.: 5033.26
<b>F8-6272</b>	<b>F8-6487</b>	<b>F8-6793</b>	<b>G9-523S</b>	<b>G9-525</b>	<b>LM-10004S</b>	<b>LM-10039S</b>
Ref.Nr.: 9556384280	Ref.Nr.: 184472	Ref.Nr.: 5094.36	Ref.Nr.: 3523.25	Ref.Nr.: 3523.31	Ref.Nr.: 7910030073	Ref.Nr.: 4066.22

Article Description



Article Nr.

Fitting Position



205 Convertible (741B, 20D)		04/1986 → 12/1994	
Stabiliser Mounting	1.1 CJ, 1.4 CJ, 1.4 CJ CAT, 1.4 CT, 1.6 CJ, 1.6 CTI, 1.9 CTI	Stabi. Diam. [mm]= 20	F8-6793
Stabiliser Mounting	1.1 CJ, 1.4 CJ, 1.4 CJ CAT, 1.4 CT, 1.6 CJ, 1.6 CTI, 1.9 CTI	Stabi. Diam. [mm]= 22	F8-6794
Stabiliser Mounting	1.1, 1.1 CJ, 1.4, 1.4 CJ, 1.4 CJ CAT, 1.4 CT, 1.6, 1.6 CJ, 1.6 CTI, 1.9 CTI		F8-6795
Engine Mounting	1.1, 1.4, 1.4 CJ, 1.4 CT		F8-6854
Repair Kit, wheel suspension	All Models		G8-272
Control Arm-/Trailing Arm Bush	1.1 CJ, 1.4 CJ, 1.4 CJ CAT, 1.4 CT, 1.6 CJ		G9-520
Control Arm-/Trailing Arm Bush	1.1 CJ, 1.4 CJ, 1.4 CJ CAT, 1.4 CT, 1.6 CJ, 1.6 CTI, 1.9 CTI		G9-523
Repair Kit, link	1.1 CJ, 1.4 CJ, 1.4 CJ CAT, 1.4 CT, 1.6 CJ, 1.6 CTI, 1.9 CTI		G9-523S
Control Arm-/Trailing Arm Bush	1.6 CTI, 1.9 CTI		G9-525
Bellow, steering	1.1, 1.1 CJ, 1.4, 1.4 CJ, 1.4 CJ CAT, 1.4 CT, 1.6, 1.6 CJ, 1.6 CTI, 1.9, 1.9 CTI	with clamps;	LM-10004S
Bellow, steering	1.1, 1.1 CJ, 1.4, 1.4 CJ, 1.4 CJ CAT, 1.4 CT, 1.6, 1.6 CJ, 1.6 CTI, 1.9, 1.9 CTI	with clamps;	LM-10004S
Bellow, steering	1.1 CJ	TU1M; with clamps;	LM-10039S
Bellow, steering	1.1, 1.4, 1.4 CJ, 1.4 CJ CAT, 1.9, 1.9 CTI	with clamps;	LM-10039S
Bellow, steering	1.4 CJ	TU3M; with clamps;	LM-10039S
Bellow, steering	1.4 CT	XY8; with clamps;	LM-10039S
Bellow, steering	1.6 CJ	XU5M; with clamps;	LM-10039S
Bellow, steering	1.9 CTi	XU9JAZ; with clamps;	LM-10039S
Bellow Set, drive shaft	1.4 CT		M-850850
Bellow Set, drive shaft	1.4 CT		MK-850850
205 Box		02/1983 → 07/1990	
Top Strut Mounting	1.1, 1.4		F8-5520
Engine Mounting	1.1, 1.4		F8-5558
Mounting, axle beam	1.1, 1.4		F8-5566
Belt Pulley, crankshaft	1.8 D		F8-5646
Rubber Buffer, suspension	1.1, 1.4	Hatchback	F8-6064
Repair Kit, wheel suspension	All Models		F8-6272
Engine Mounting	1.1, 1.4		F8-6487
Repair Kit, wheel suspension	All Models		G8-272

<b>AK-735010</b>	<b>F8-5520</b>	<b>F8-5558</b>	<b>F8-5566</b>	<b>F8-5646</b>	<b>F8-6064</b>	<b>F8-6272</b>
Ref.Nr.: 503518	Ref.Nr.: 503518	Ref.Nr.: 1843.97	Ref.Nr.: 515110	Ref.Nr.: 0515K9	Ref.Nr.: 5033.26	Ref.Nr.: 9556384280
<b>F8-6487</b>	<b>F8-6793</b>	<b>F8-6794</b>	<b>F8-6795</b>	<b>F8-6854</b>	<b>G8-272</b>	<b>G9-520</b>
Ref.Nr.: 184472	Ref.Nr.: 5094.36	Ref.Nr.: 5094.37	Ref.Nr.: 5094.40	Ref.Nr.: 1807.45	Ref.Nr.: 5132.49	Ref.Nr.: 96096727
<b>G9-523</b>	<b>G9-523S</b>	<b>G9-525</b>	<b>LM-10004S</b>	<b>LM-10039S</b>	<b>M-850850</b>	<b>MK-850850</b>
Ref.Nr.: 3523.25	Ref.Nr.: 3523.25	Ref.Nr.: 3523.31	Ref.Nr.: 7910030073	Ref.Nr.: 4066.22	Ref.Nr.: 329373	Ref.Nr.: 329373

**Article Description****Article Nr.****Fitting Position**

<b>205 Mk II (20A/C)</b>		<b>01/1987 → 09/1998</b>	
Dust Cover Kit, shock absorber	1.0, 1.1, 1.3 Rallye, 1.4, 1.4 CAT, 1.6, 1.6 Aut., 1.6 GTI, 1.7 Diesel, 1.7 TD, 1.9 Diesel, 1.9 GTI, 1.9 GTI CAT	<b>AK-735010</b>	
Anti-Friction Bearing	1.0, 1.1, 1.2, 1.3 Rallye, 1.4, 1.4 CAT, 1.6, 1.6 Aut., 1.6 GTI, 1.7 Diesel, 1.7 TD, 1.9 Diesel, 1.9 GTI, 1.9 GTI CAT	<b>F8-3012</b>	H=20; d=66; D=100
Engine Mounting	1.6 Aut., 1.9 Diesel, 1.9 GTI	<b>F8-5026</b>	d=10; D=70; Thick. [mm]=40, 53
Control Arm-/Trailing Arm Bush	1.6 GTI, 1.7 TD, 1.9 GTI, 1.9 GTI CAT	<b>F8-5072</b>	d=12; D=42; W=38
Control Arm-/Trailing Arm Bush	1.0, 1.1, 1.3 Rallye, 1.4, 1.4 CAT, 1.6, 1.6 Aut., 1.7 Diesel, 1.7 TD, 1.9 Diesel	<b>F8-5078</b>	d=12; D=36; Thick. [mm]=25
Bellow, driveshaft	1.0, 1.1, 1.3 Rallye, 1.4, 1.4 CAT	Transmission Type: MA <b>F8-5356</b>	D1=72; D219; L=172
Bellow, driveshaft	1.6 GTI	<b>F8-5356</b>	D1=72; D219; L=172
Bellow, driveshaft	1.6, 1.9 Diesel	<b>F8-5356</b>	D1=72; D219; L=172
Engine Mounting	1.6, 1.6 Aut., 1.7 Diesel, 1.9 GTI, 1.9 GTI CAT	<b>F8-5358</b>	
Engine Mounting	1.0, 1.1, 1.1 XA, 1.2, 1.3, 1.3 Rallye, 1.4, 1.4 CAT, 1.6, 1.6 Aut., 1.6 GTI, 1.6 GTX, 1.7 Diesel, 1.8 XDT, 1.9, 1.9 Diesel, 1.9 GTI, 1.9 GTI CAT	<b>F8-5375</b>	H=34; d=12; D=30
Top Strut Mounting	1.0, 1.1, 1.1 XA, 1.2, 1.3, 1.3 Rallye, 1.4, 1.4 CAT, 1.6, 1.6 Aut., 1.6 GTI, 1.6 GTX, 1.7 Diesel, 1.7 TD, 1.8 XDT, 1.9, 1.9 Diesel, 1.9 GTI, 1.9 GTI CAT	<b>F8-5520</b>	
Engine Mounting	1.0, 1.1, 1.4	<b>F8-5555</b>	
Engine Mounting	1.4	TU3M <b>F8-5555</b>	
Engine Mounting	1.0, 1.1, 1.2, 1.4, 1.4 CAT, 1.6, 1.6 Aut., 1.6 GTI, 1.7 Diesel, 1.9 Diesel, 1.9 GTI, 1.9 GTI CAT	<b>F8-5556</b>	
Engine Mounting	1.0, 1.1, 1.1 XA, 1.2, 1.3, 1.4, 1.4 CAT, 1.6, 1.6 Aut., 1.6 GTI, 1.6 GTX, 1.7 Diesel, 1.7 TD, 1.8 XDT, 1.9, 1.9 Diesel, 1.9 GTI, 1.9 GTI CAT	<b>F8-5558</b>	
Engine Mounting	1.4	TU3M <b>F8-5558</b>	
Engine Mounting	1.6	XU5CP <b>F8-5558</b>	
Mounting, axle beam	1.0, 1.1, 1.1 XA, 1.2, 1.3, 1.3 Rallye, 1.4, 1.4 CAT, 1.6, 1.6 Aut., 1.6 GTI, 1.6 GTX, 1.7 Diesel, 1.8 XDT, 1.9, 1.9 Diesel, 1.9 GTI, 1.9 GTI CAT	<b>F8-5566</b>	
Belt Pulley, crankshaft	1.7 Diesel, 1.9 Diesel	<b>F8-5646</b>	
Rubber Buffer, suspension	1.0, 1.1, 1.2, 1.4, 1.4 CAT, 1.6, 1.6 Aut., 1.7 Diesel	<b>F8-5798</b>	L=57
Repair Set, axle beam	1.0, 1.1, 1.4, 1.4 CAT, 1.6, 1.6 Aut., 1.7 Diesel, 1.7 TD, 1.9 Diesel	<b>F8-5855</b>	H=34; D=30, 41
Rubber Buffer, suspension	1.0, 1.1, 1.1 XA, 1.2, 1.3, 1.4, 1.4 CAT, 1.6, 1.6 Aut., 1.6 GTX, 1.7 Diesel, 1.9 Diesel	<b>F8-6064</b>	L=79
Repair Kit, wheel suspension	All Models	<b>F8-6272</b>	
Engine Mounting	1.1, 1.1 XA, 1.2, 1.3, 1.4, 1.4 CAT, 1.6, 1.6 Aut., 1.6 GTX	<b>F8-6487</b>	

<b>AK-735010</b>	<b>F8-3012</b>	<b>F8-5026</b>	<b>F8-5072</b>	<b>F8-5078</b>	<b>F8-5356</b>	<b>F8-5358</b>
Ref.Nr.:	Ref.Nr.: 503527	Ref.Nr.: 9606121080	Ref.Nr.: 3523.23	Ref.Nr.: 2523.29	Ref.Nr.: 328769	Ref.Nr.: 184373
<b>F8-5375</b>	<b>F8-5520</b>	<b>F8-5555</b>	<b>F8-5556</b>	<b>F8-5558</b>	<b>F8-5566</b>	<b>F8-5646</b>
Ref.Nr.: 180906	Ref.Nr.: 503518	Ref.Nr.: 97521102	Ref.Nr.: 1843.95	Ref.Nr.: 1843.97	Ref.Nr.: 515110	Ref.Nr.: 0515K9
<b>F8-5798</b>	<b>F8-5855</b>	<b>F8-6064</b>	<b>F8-6272</b>	<b>F8-6487</b>		
Ref.Nr.: 5033.23	Ref.Nr.: 5131.43	Ref.Nr.: 5033.26	Ref.Nr.: 9556384280	Ref.Nr.: 184472		

Article Description



Article Nr.

Fitting Position



**205 Mk II (20A/C)**

01/1987 → 09/1998

Engine Mounting	1.1, 1.4	08/1990 →	F8-6487	⊕	
Engine Mounting	1.6	XU5CP	F8-6487	⊕	
Stabiliser Mounting	1.0, 1.1, 1.2, 1.3 Rallye, 1.4, 1.4 CAT, 1.6, 1.6 Aut., 1.6 GTI, 1.6 GTX, 1.7 Diesel, 1.7 TD, 1.9 Diesel, 1.9 GTI, 1.9 GTI CAT	Stabi. Diam. [mm]= 20	F8-6793		d=18
Stabiliser Mounting	1.0, 1.1, 1.2, 1.3 Rallye, 1.4, 1.4 CAT, 1.6, 1.6 Aut., 1.6 GTI, 1.6 GTX, 1.7 Diesel, 1.7 TD, 1.9 Diesel, 1.9 GTI, 1.9 GTI CAT	Stabi. Diam. [mm]= 22	F8-6794		d=22
Stabiliser Mounting	1.0, 1.1, 1.1 XA, 1.2, 1.3, 1.3 Rallye, 1.4, 1.4 CAT, 1.6, 1.6 Aut., 1.6 GTI, 1.6 GTX, 1.7 Diesel, 1.7 TD, 1.9 Diesel, 1.9 GTI, 1.9 GTI CAT		F8-6795		D=23; d=22
Engine Mounting	1.0, 1.1, 1.1 XA, 1.3, 1.4		F8-6854	⊕ ↓	
Engine Mounting	1.2		F8-6899	⊕	
Repair Kit, wheel suspension	All Models		G8-272		
Control Arm-/Trailing Arm Bush	1.0, 1.1, 1.3 Rallye, 1.4, 1.4 CAT, 1.6, 1.6 Aut., 1.7 Diesel, 1.9 Diesel		G9-520	⊕ ⊕ ↓	H1=34; H2=28; d=10; D=28
Control Arm-/Trailing Arm Bush	1.0, 1.1, 1.3 Rallye, 1.4, 1.4 CAT, 1.6, 1.6 Aut., 1.7 Diesel, 1.7 TD, 1.9 Diesel		G9-523	⊕ ⊕	H=25; d=12; D1=36; D2=47
Repair Kit, link	1.0, 1.1, 1.3 Rallye, 1.4, 1.4 CAT, 1.6, 1.6 Aut., 1.7 Diesel, 1.7 TD, 1.9 Diesel		G9-523S	⊕ ⊕	H=25; d=12; D1=36; D2=47
Control Arm-/Trailing Arm Bush	1.0, 1.1, 1.4, 1.4 CAT, 1.6 Aut., 1.6 GTI, 1.7 TD, 1.9 Diesel, 1.9 GTI, 1.9 GTI CAT		G9-525	⊕ ⊕ ↓	H=34; d=10; D=28
Bellow, steering	1.0, 1.1, 1.1 XA, 1.2, 1.3, 1.3 Rallye, 1.4, 1.4 CAT, 1.6, 1.6 Aut., 1.6 GTI, 1.6 GTX, 1.7 Diesel, 1.7 TD, 1.8 XDT, 1.9, 1.9 Diesel, 1.9 GTI, 1.9 GTI CAT	with clamps;	LM-10004S	⊕	d1=10; d2=40; L [mm]=175
Bellow, steering	1.0, 1.1, 1.1 XA, 1.2, 1.3, 1.3 Rallye, 1.4, 1.4 CAT, 1.6, 1.6 Aut., 1.6 GTI, 1.6 GTX, 1.7 Diesel, 1.7 TD, 1.8 XDT, 1.9, 1.9 Diesel, 1.9 GTI, 1.9 GTI CAT	with clamps;	LM-10004S	⊕ ⊕	d1=10; d2=40; L [mm]=175
Bellow, steering	1.0, 1.1, 1.1 XA, 1.2, 1.3 Rallye, 1.4, 1.4 CAT, 1.6, 1.8 XDT, 1.9, 1.9 Diesel, 1.9 GTI, 1.9 GTI CAT	with clamps;	LM-10039S		d1=40; d2=40; L [mm]=115
Bellow, steering	1.1	TU1M; with clamps;	LM-10039S		d1=40; d2=40; L [mm]=115
Bellow, steering	1.3	G1A; with clamps;	LM-10039S		d1=40; d2=40; L [mm]=115
Bellow, steering	1.4	G2S; with clamps;	LM-10039S		d1=40; d2=40; L [mm]=115
Bellow, steering	1.4	TU3; with clamps;	LM-10039S		d1=40; d2=40; L [mm]=115
Bellow, steering	1.4	TU32; with clamps;	LM-10039S		d1=40; d2=40; L [mm]=115
Bellow, steering	1.4	TU3M; with clamps;	LM-10039S		d1=40; d2=40; L [mm]=115
Bellow, steering	1.4	TU3MC; with clamps;	LM-10039S		d1=40; d2=40; L [mm]=115
Bellow, steering	1.6	XU5CP; with clamps;	LM-10039S		d1=40; d2=40; L [mm]=115
Bellow, steering	1.6 Aut.	XU51C; with clamps;	LM-10039S		d1=40; d2=40; L [mm]=115
Bellow, steering	1.6 Aut.	XU5M; with clamps;	LM-10039S		d1=40; d2=40; L [mm]=115
Bellow, steering	1.6 GTI	XU5JA; with clamps;	LM-10039S		d1=40; d2=40; L [mm]=115



**Article Description****Article Nr.****Fitting Position****205 Mk II (20A/C)****01/1987 → 09/1998**

Bellow, steering	1.6 GTX	J2; with clamps;	<b>LM-10039S</b>		d1=40; d2=40; L [mm]=115
Bellow, steering	1.7 Diesel	XUD7; with clamps;	<b>LM-10039S</b>		d1=40; d2=40; L [mm]=115
Bellow Set, drive shaft	1.4		<b>M-850850</b>		H=120; d1=28; d2=75.5
Bellow Set, drive shaft	1.4		<b>MK-850850</b>		

**205 Van****03/1994 →**

Dust Cover Kit, shock absorber	All Models		<b>AK-735010</b>		
Anti-Friction Bearing	All Models		<b>F8-3012</b>		H=20; d=66; D=100
Top Strut Mounting	All Models		<b>F8-5520</b>		
Belt Pulley, crankshaft	All Models		<b>F8-5646</b>		
Repair Kit, wheel suspension	All Models		<b>F8-6272</b>		
Stabiliser Mounting	All Models	Stabi. Diam. [mm]= 20	<b>F8-6793</b>		d=18
Stabiliser Mounting	All Models	Stabi. Diam. [mm]= 22	<b>F8-6794</b>		d=22
Stabiliser Mounting	All Models		<b>F8-6795</b>		D=23; d=22
Repair Kit, wheel suspension	All Models		<b>G8-272</b>		
Control Arm-/Trailing Arm Bush	All Models		<b>G9-520</b>		H1=34; H2=28; d=10; D=28
Control Arm-/Trailing Arm Bush	All Models		<b>G9-523</b>		H=25; d=12; D1=36; D2=47
Repair Kit, link	All Models		<b>G9-523S</b>		H=25; d=12; D1=36; D2=47
Bellow, steering	1.7 Diesel	with clamps;	<b>LM-10004S</b>		d1=10; d2=40; L [mm]=175
Bellow, steering	1.7 Diesel	with clamps;	<b>LM-10004S</b>		d1=10; d2=40; L [mm]=175
Bellow, steering	All Models	with clamps;	<b>LM-10039S</b>		d1=40; d2=40; L [mm]=115

**206 CC (2D)****09/2000 →**

Alternator Freewheel Clutch	1.6 HDi 110		<b>F5-1046</b>		
Alternator Freewheel Clutch	1.6 HDi 110		<b>F5-1048</b>		
Anti-Friction Bearing	1.6 16V, 1.6 HDi 110, 2.0 S16		<b>F8-3012</b>		H=20; d=66; D=100
Mounting, axle beam	1.6 16V, 1.6 HDi 110, 2.0 S16		<b>F8-5989</b>		d=17; L=61; D=48.3
Mounting, axle beam	1.6 16V, 1.6 HDi 110, 2.0 S16		<b>F8-5990</b>		H=69,5; d=17; W=48,5
Top Strut Mounting	1.6 16V, 2.0 S16		<b>F8-6020</b>		
Top Strut Mounting	1.6 16V, 2.0 S16		<b>F8-6021</b>		
Engine Mounting	2.0 S16		<b>F8-6236</b>		H1=53; H2=40; d=10; D=70
Repair Kit, wheel suspension	1.6 16V, 1.6 HDi 110, 2.0 S16	Orga.→9500;	<b>F8-6248</b>		
Repair Kit, wheel suspension	1.6 16V, 1.6 HDi 110, 2.0 S16	ch.→9500;	<b>F8-6277</b>		
Repair Kit, wheel suspension	1.6 16V, 1.6 HDi 110, 2.0 S16	Orga.9500→;	<b>F8-6277</b>		
Belt Pulley, crankshaft	1.6 16V	Number of Ribs: 5; Parameter: 6PK	<b>F8-6394</b>		H=25; d=44.05; Mounting points diam. [mm]=9; D=148; D1=142.9

<b>AK-735010</b>	<b>F5-1046</b>	<b>F5-1048</b>	<b>F8-3012</b>	<b>F8-5520</b>	<b>F8-5646</b>	<b>F8-5989</b>
Ref.Nr.:	Ref.Nr.: 30667687	Ref.Nr.: 77363468	Ref.Nr.: 503527	Ref.Nr.: 503518	Ref.Nr.: 0515K9	Ref.Nr.: 5131.93
<b>F8-5990</b>	<b>F8-6020</b>	<b>F8-6021</b>	<b>F8-6236</b>	<b>F8-6248</b>	<b>F8-6272</b>	<b>F8-6277</b>
Ref.Nr.: 5131.94	Ref.Nr.: 5031.A2	Ref.Nr.: 5031.A1	Ref.Nr.: 1809.21	Ref.Nr.: 5131.49	Ref.Nr.: 9556384280	Ref.Nr.: 5174.05
<b>F8-6394</b>	<b>F8-6486</b>	<b>F8-6793</b>	<b>F8-6794</b>	<b>F8-6795</b>	<b>G8-272</b>	<b>G9-520</b>
Ref.Nr.: 0515.R8	Ref.Nr.: 1844.77	Ref.Nr.: 5094.36	Ref.Nr.: 5094.37	Ref.Nr.: 5094.40	Ref.Nr.: 5132.49	Ref.Nr.: 96096727

**Article Description**

**Article Nr.**
**Fitting Position**

<b>206 CC (2D)</b>			<b>09/2000 →</b>		
Engine Mounting	1.6 16V, 1.6 HDi 110, 2.0 S16		<b>F8-6486</b>		
Engine Mounting	1.6 HDi 110, 2.0 S16		<b>F8-6500</b>		
Mounting, automatic transmission	1.6 16V		<b>F8-6505</b>		
Belt Pulley, crankshaft	1.6 HDi 110	Number of Ribs: 6	<b>F8-7082</b>		Belt Pulley Ø [mm]=152; Mounting points diam.[mm]=30; W=34
Repair Kit, wheel suspension	1.6 16V, 1.6 HDi 110, 2.0 S16		<b>F8-7197</b>		
Engine Mounting	1.6 HDi 110, 2.0 S16		<b>F8-8184</b>		
Repair Kit, wheel suspension	1.6 16V, 1.6 HDi 110, 2.0 S16		<b>G8-197</b>		
Repair Kit, wheel suspension	1.6 16V, 1.6 HDi 110, 2.0 S16	Orga.→9500;	<b>G8-248</b>		
Repair Kit, wheel suspension	1.6 16V, 1.6 HDi 110, 2.0 S16	ch.→9500;	<b>G8-277</b>		
Repair Kit, wheel suspension	1.6 16V, 1.6 HDi 110, 2.0 S16	Orga.9500→;	<b>G8-277</b>		
Control Arm-/Trailing Arm Bush	1.6 16V, 2.0 S16		<b>G9-698</b>		H=50.5; d=14; D=55.5
Control Arm-/Trailing Arm Bush	1.6 16V, 2.0 S16		<b>G9-699</b>		H=48.8; d=14; D=55.4
Bellow, steering	1.6 16V, 1.6 HDi 110, 2.0 S16	with clamps;	<b>LM-10010S</b>		d1=16; d2=49; L [mm]=200
Bellow, steering	1.6 16V, 1.6 HDi 110, 2.0 S16	; with clamps;	<b>LM-10040S</b>		d1=17; d2=60; L [mm]=183
<b>206 Hatchback (2A/C)</b>			<b>08/1998 → 07/2008</b>		
Alternator Freewheel Clutch	2.0 HDI 90		<b>F5-1020</b>		
Alternator Freewheel Clutch	1.4 HDi, 1.4 HDi eco 70, 1.6 HDi 110, 2.0 HDI 90		<b>F5-1046</b>		
Alternator Freewheel Clutch	1.4 HDi, 1.4 HDi eco 70, 1.6 HDi 110, 2.0 HDI 90		<b>F5-1048</b>		
Anti-Friction Bearing	1.1, 1.1 i, 1.4 16V, 1.4 HDi, 1.4 HDi eco 70, 1.4 i, 1.4 LPG, 1.6 16V, 1.6 HDi 110, 1.6 i, 1.9 D, 2.0 HDI 90, 2.0 RC, 2.0 S16		<b>F8-3012</b>		H=20; d=66; D=100
Engine Mounting	1.1 i, 1.4 i, 1.6 16V, 1.6 i		<b>F8-5556</b>		
Belt Pulley, crankshaft	1.9 D	Orga.09895→;	<b>F8-5636</b>		d=30
Belt Pulley, crankshaft	2.0 HDI 90		<b>F8-5636</b>		d=30
Belt Pulley, crankshaft	1.9 D	ch.→O09894	<b>F8-5659</b>		
Belt Pulley, crankshaft	2.0 HDI 90	ch.O09361→	<b>F8-5660</b>		
Mounting, axle beam	1.1, 1.1 i, 1.4 16V, 1.4 HDi eco 70, 1.4 i, 1.6 16V, 1.6 HDi 110, 1.6 i, 1.9 D, 2.0 HDI 90, 2.0 RC, 2.0 S16		<b>F8-5989</b>		d=17; L=61; D=48.3
Mounting, axle beam	1.1, 1.1 i, 1.4 16V, 1.4 HDi eco 70, 1.4 i, 1.6 16V, 1.6 HDi 110, 1.6 i, 1.9 D, 2.0 HDI 90, 2.0 RC, 2.0 S16		<b>F8-5990</b>		H=69.5; d=17; W=48.5
Top Strut Mounting	1.1, 1.1 i, 1.4 HDi eco 70, 1.9 D		<b>F8-6018</b>		
Top Strut Mounting	1.1 i, 1.4 HDi eco 70, 1.9 D		<b>F8-6019</b>		
Top Strut Mounting	1.1 i, 1.4 16V, 1.4 HDi eco 70, 1.4 i, 1.6 16V, 1.6 HDi 110, 1.6 i, 1.9 D, 2.0 HDI 90, 2.0 RC, 2.0 S16		<b>F8-6020</b>		

<b>F5-1020</b>	<b>F5-1046</b>	<b>F5-1048</b>	<b>F8-3012</b>	<b>F8-5556</b>	<b>F8-5636</b>	<b>F8-5659</b>
Ref.Nr.: 31771-68D01	Ref.Nr.: 30667687	Ref.Nr.: 77363468	Ref.Nr.: 503527	Ref.Nr.: 1843.95	Ref.Nr.: 0515P2	Ref.Nr.: 0515Q6
<b>F8-5660</b>	<b>F8-5989</b>	<b>F8-5990</b>	<b>F8-6018</b>	<b>F8-6019</b>	<b>F8-6020</b>	<b>F8-6021</b>
Ref.Nr.: 0515R9	Ref.Nr.: 5131.93	Ref.Nr.: 5131.94	Ref.Nr.: 5031.57	Ref.Nr.: 5031.59	Ref.Nr.: 5031.A2	Ref.Nr.: 5031.A1
<b>F8-6486</b>	<b>F8-6500</b>	<b>F8-6505</b>	<b>F8-7082</b>	<b>F8-7197</b>	<b>F8-8184</b>	<b>G8-197</b>
Ref.Nr.: 1844.77	Ref.Nr.: 1844.36	Ref.Nr.: 1844.51	Ref.Nr.: 0515.R0	Ref.Nr.: 5132.72	Ref.Nr.: 1806.33	Ref.Nr.: 5131.A6



**Article Description****Article Nr.****Fitting Position**

<b>206 Hatchback (2A/C)</b>				<b>08/1998 → 07/2008</b>	
Top Strut Mounting	1.1 i, 1.4 16V, 1.4 HDi eco 70, 1.4 i, 1.6 16V, 1.6 HDi 110, 1.6 i, 1.9 D, 2.0 HDi 90, 2.0 RC, 2.0 S16		<b>F8-6021</b>		
Rubber Buffer, suspension	1.1, 1.1 i, 1.4 HDi eco 70, 1.4 i, 1.6 16V, 1.6 i, 1.9 D, 2.0 HDi 90, 2.0 S16		<b>F8-6063</b>		H=73
Stabiliser Mounting	1.1, 1.1 i, 1.4 i, 1.9 D	Orga.→09275	<b>F8-6125</b>		d=18
Stabiliser Mounting	1.6 16V, 1.6 i	Orga.→09122	<b>F8-6127</b>		d=19
Stabiliser Mounting	2.0 HDi 90	Orga.→09085	<b>F8-6127</b>		d=19
Engine Mounting	1.9 D, 2.0 HDi 90, 2.0 S16		<b>F8-6236</b>		H1=53; H2=40; d=10; D=70
Repair Kit, wheel suspension	1.6 16V, 2.0 S16	Orga.→9500;	<b>F8-6248</b>		
Repair Kit, wheel suspension	1.0, 1.1, 1.1 i, 1.4 16V, 1.4 HDi, 1.4 HDi eco 70, 1.4 i, 1.4 LPG, 1.6, 1.6 16V, 1.6 HDi 110, 1.6 i, 1.9 D, 2.0 HDi 90, 2.0 RC		<b>F8-6277</b>		
Repair Kit, wheel suspension	2.0 S16	ch.→9500;	<b>F8-6277</b>		
Repair Kit, wheel suspension	2.0 S16	Orga.9500→;	<b>F8-6277</b>		
Top Strut Mounting	1.1 i, 1.4 HDi eco 70, 1.9 D		<b>F8-6299</b>		
Belt Pulley, crankshaft	1.1 i, 1.4 i	Number of Ribs: 5; Orga.→10191; Parameter: 6PK;	<b>F8-6394</b>		H=25; d=44.05; Mounting points diam.[mm]=9; D=148; D1=142.9
Belt Pulley, crankshaft	1.1, 1.4 16V, 1.4 LPG, 1.6 16V	Number of Ribs: 5; Parameter: 6PK	<b>F8-6394</b>		H=25; d=44.05; Mounting points diam.[mm]=9; D=148; D1=142.9
Belt Pulley, crankshaft	1.6 i	Number of Ribs: 5; Parameter: 6PK;	<b>F8-6394</b>		H=25; d=44.05; Mounting points diam.[mm]=9; D=148; D1=142.9
Engine Mounting	1.6 16V, 1.6 HDi 110, 1.9 D, 2.0 HDi 90, 2.0 RC, 2.0 S16		<b>F8-6486</b>		
Engine Mounting	1.1, 1.1 i, 1.4 16V, 1.4 i, 1.6 i		<b>F8-6487</b>		
Engine Mounting	1.4 HDi eco 70	DV4TD	<b>F8-6497</b>		
Engine Mounting	1.6 i		<b>F8-6497</b>		
Engine Mounting	1.6 HDi 110	DV6TED4	<b>F8-6500</b>		
Engine Mounting	1.9 D	DW8	<b>F8-6500</b>		
Engine Mounting	2.0 HDi 90, 2.0 RC, 2.0 S16		<b>F8-6500</b>		
Mounting, automatic transmission	1.1, 1.1 i, 1.4 16V, 1.4 HDi eco 70, 1.4 i, 1.6 16V, 1.6 i		<b>F8-6505</b>		
Belt Pulley, crankshaft	1.6 HDi 110	Number of Ribs: 6	<b>F8-7082</b>		Belt Pulley Ø [mm]=152; Mounting points diam.[mm]=30; W=34
Top Strut Mounting	1.1 i		<b>F8-7163</b>		
Top Strut Mounting	1.4 HDi eco 70, 1.9 D		<b>F8-7163</b>		
Repair Kit, wheel suspension	1.1, 1.1 i, 1.4 16V, 1.4 HDi, 1.4 HDi eco 70, 1.4 i, 1.4 LPG, 1.6 16V, 1.6 HDi 110, 1.6 i, 1.9 D, 2.0 HDi 90, 2.0 RC, 2.0 S16		<b>F8-7197</b>		
Belt Pulley, crankshaft	1.9 D	Orga.09895→;	<b>F8-7862</b>		

<b>F8-6021</b>	<b>F8-6063</b>	<b>F8-6125</b>	<b>F8-6127</b>	<b>F8-6236</b>	<b>F8-6248</b>	<b>F8-6277</b>
Ref.Nr.: 5031.A1	Ref.Nr.: 5033.58	Ref.Nr.: 5094.81	Ref.Nr.: 5094.80	Ref.Nr.: 1809.21	Ref.Nr.: 5131.49	Ref.Nr.: 5174.05
<b>F8-6299</b>	<b>F8-6394</b>	<b>F8-6486</b>	<b>F8-6487</b>	<b>F8-6497</b>	<b>F8-6500</b>	<b>F8-6505</b>
Ref.Nr.: 5038.56	Ref.Nr.: 0515.R8	Ref.Nr.: 1844.77	Ref.Nr.: 1844.72	Ref.Nr.: 1844.75	Ref.Nr.: 1844.36	Ref.Nr.: 1844.51
<b>F8-7082</b>	<b>F8-7163</b>	<b>F8-7197</b>	<b>F8-7862</b>	<b>F8-7975</b>		
Ref.Nr.: 0515.R0	Ref.Nr.: 5038.39	Ref.Nr.: 5132.72	Ref.Nr.: 0515 R5	Ref.Nr.: 5094.82		

Article Description



Article Nr.

Fitting Position



**206 Hatchback (2A/C)** 08/1998 → 07/2008

Stabiliser Mounting	1.1 i, 1.4 16V, 1.4 HDi eco 70, 1.4 i, 1.6 16V, 1.6 HDi 110, 1.6 i, 1.9 D, 2.0 HDi 90, 2.0 RC, 2.0 S16		F8-7975		
Engine Mounting	1.6 HDi 110, 2.0 S16		F8-8184		
Repair Kit, wheel suspension	1.1, 1.1 i, 1.4 16V, 1.4 HDi, 1.4 HDi eco 70, 1.4 i, 1.4 LPG, 1.6 16V, 1.6 HDi 110, 1.6 i, 1.9 D, 2.0 HDi 90, 2.0 RC, 2.0 S16		G8-197		
Repair Kit, wheel suspension	1.6 16V, 2.0 S16	Orga.→9500;	G8-248		
Repair Kit, wheel suspension	1.0, 1.1, 1.1 i, 1.4 16V, 1.4 HDi, 1.4 HDi eco 70, 1.4 i, 1.4 LPG, 1.6, 1.6 16V, 1.6 HDi 110, 1.6 i, 1.9 D, 2.0 HDi 90, 2.0 RC		G8-277		
Repair Kit, wheel suspension	2.0 S16	ch.→9500;	G8-277		
Repair Kit, wheel suspension	2.0 S16	Orga.9500→;	G8-277		
Control Arm-/Trailing Arm Bush	1.1 i, 1.4 HDi eco 70, 1.4 i, 1.6 16V, 1.6 i, 1.9 D, 2.0 HDi 90, 2.0 S16		G9-698		H=50.5; d=14; D=55.5
Control Arm-/Trailing Arm Bush	1.1 i, 1.4 HDi eco 70, 1.4 i, 1.6 16V, 1.6 i, 1.9 D, 2.0 HDi 90, 2.0 S16		G9-699		H=48.8; d=14; D=55.4
Bellow, steering	1.1, 1.1 i, 1.4 16V, 1.4 HDi, 1.4 HDi eco 70, 1.4 i, 1.4 LPG, 1.6 16V, 1.6 HDi 110, 1.6 i, 1.9 D, 2.0 HDi 90, 2.0 RC, 2.0 S16	with clamps;	LM-10010S		d1=16; d2=49; L [mm]=200
Bellow, steering	1.0, 1.1, 1.1 i, 1.4 16V, 1.4 HDi, 1.4 HDi eco 70, 1.4 i, 1.4 LPG, 1.6 16V, 1.6 HDi 110, 1.6 i, 1.9 D, 2.0 HDi 90, 2.0 RC, 2.0 S16	; ; with clamps;	LM-10040S		d1=17; d2=60; L [mm]=183

**206 SW (2E/K)** 07/2002 → 07/2008

Alternator Freewheel Clutch	2.0 HDi		F5-1020		
Alternator Freewheel Clutch	1.4 HDi, 1.6 HDi 110, 2.0 HDi		F5-1046		
Alternator Freewheel Clutch	1.4 HDi, 1.6 HDi 110, 2.0 HDi		F5-1048		
Anti-Friction Bearing	1.1, 1.4, 1.4 16V, 1.4 HDi, 1.6 16V, 1.6 HDi 110, 2.0 16V, 2.0 HDi		F8-3012		H=20; d=66; D=100
Belt Pulley, crankshaft	2.0 HDi	Orga.→09360	F8-5636		d=30
Belt Pulley, crankshaft	2.0 HDi	Orga.09361→	F8-5660		
Mounting, axle beam	1.1, 1.4, 1.4 16V, 1.4 HDi, 1.6 16V, 1.6 HDi 110, 2.0 16V, 2.0 HDi		F8-5989		d=17; L=61; D=48.3
Mounting, axle beam	1.1, 1.4, 1.4 16V, 1.4 HDi, 1.6 16V, 1.6 HDi 110, 2.0 16V, 2.0 HDi		F8-5990		H=69.5; d=17; W=48.5
Top Strut Mounting	1.1, 1.4 HDi	; ;	F8-6018		
Top Strut Mounting	1.4 HDi	; ;	F8-6019		
Top Strut Mounting	1.1, 1.4, 1.4 HDi, 1.6 16V, 1.6 HDi 110, 2.0 16V, 2.0 HDi	; ;	F8-6020		
Top Strut Mounting	1.1, 1.4, 1.4 HDi, 1.6 16V, 1.6 HDi 110, 2.0 16V, 2.0 HDi	; ;	F8-6021		
Stabiliser Mounting	1.4	Orga.→09275	F8-6125		d=18

<b>F5-1020</b>	<b>F5-1046</b>	<b>F5-1048</b>	<b>F8-3012</b>	<b>F8-5636</b>	<b>F8-5660</b>	<b>F8-5989</b>
Ref.Nr.: 31771-68D01	Ref.Nr.: 30667687	Ref.Nr.: 77363468	Ref.Nr.: 503527	Ref.Nr.: 0515P2	Ref.Nr.: 0515R9	Ref.Nr.: 5131.93
<b>F8-5990</b>	<b>F8-6018</b>	<b>F8-6019</b>	<b>F8-6020</b>	<b>F8-6021</b>	<b>F8-6125</b>	<b>F8-6127</b>
Ref.Nr.: 5131.94	Ref.Nr.: 5031.57	Ref.Nr.: 5031.59	Ref.Nr.: 5031.A2	Ref.Nr.: 5031.A1	Ref.Nr.: 5094.81	Ref.Nr.: 5094.80
<b>F8-7975</b>	<b>F8-8184</b>	<b>G8-197</b>	<b>G8-248</b>	<b>G8-277</b>	<b>G9-698</b>	<b>G9-699</b>
Ref.Nr.: 5094.82	Ref.Nr.: 1806.33	Ref.Nr.: 5131.A6	Ref.Nr.: 5174.06	Ref.Nr.: 5174.05	Ref.Nr.: 352376	Ref.Nr.: 96286665

**Article Description****Article Nr.****Fitting Position****206 SW (2E/K) 07/2002 → 07/2008**

Stabiliser Mounting	1.6 16V	Orga.→09122	<b>F8-6127</b>		d=19
Stabiliser Mounting	2.0 HDi	Orga.→09085	<b>F8-6127</b>		d=19
Engine Mounting	2.0 16V, 2.0 HDi		<b>F8-6236</b>		H1=53; H2=40; d=10; D=70
Repair Kit, wheel suspension	All Models		<b>F8-6277</b>		
Top Strut Mounting	1.4 HDi		<b>F8-6299</b>		
Belt Pulley, crankshaft	1.1, 1.4, 1.4 16V, 1.6 16V	Number of Ribs: 5; Parameter: 6PK	<b>F8-6394</b>		H=25; d=44.05; Mounting points diam.[mm]=9; D=148; D1=142.9
Engine Mounting	1.6 16V, 1.6 HDi 110, 2.0 16V, 2.0 HDi		<b>F8-6486</b>		
Engine Mounting	1.1, 1.4 16V		<b>F8-6487</b>		
Engine Mounting	1.4	TU3JP	<b>F8-6487</b>		
Engine Mounting	1.4 HDi		<b>F8-6497</b>		
Engine Mounting	1.6 HDi 110, 2.0 16V, 2.0 HDi		<b>F8-6500</b>		
Mounting, automatic transmission	1.1, 1.4 16V, 1.4 HDi, 1.6 16V		<b>F8-6505</b>		
Mounting, automatic transmission	1.4	TU3JP	<b>F8-6505</b>		
Belt Pulley, crankshaft	1.6 HDi 110	Number of Ribs: 6	<b>F8-7082</b>		Belt Pulley Ø [mm]=152; Mounting points diam.[mm]=30; W=34
Top Strut Mounting	1.4 HDi		<b>F8-7163</b>		
Repair Kit, wheel suspension	All Models		<b>F8-7197</b>		
Engine Mounting	1.6 HDi 110, 2.0 16V		<b>F8-8184</b>		
Repair Kit, wheel suspension	All Models		<b>G8-197</b>		
Repair Kit, wheel suspension	All Models		<b>G8-277</b>		
Control Arm-/Trailing Arm Bush	1.4, 1.4 HDi, 1.6 16V, 2.0 16V, 2.0 HDi		<b>G9-698</b>		H=50.5; d=14; D=55.5
Control Arm-/Trailing Arm Bush	1.4, 1.4 HDi, 1.6 16V, 2.0 16V, 2.0 HDi		<b>G9-699</b>		H=48.8; d=14; D=55.4
Bellow, steering	1.1, 1.4, 1.4 16V, 1.4 HDi, 1.6 16V, 1.6 HDi 110, 2.0 16V, 2.0 HDi	with clamps;	<b>LM-10010S</b>		d1=16; d2=49; L [mm]=200
Bellow, steering	1.1, 1.4, 1.4 16V, 1.4 HDi, 1.6 16V, 1.6 HDi 110, 2.0 16V, 2.0 HDi	; with clamps;	<b>LM-10040S</b>		d1=17; d2=60; L [mm]=183

**206 Van 04/1999 → 03/2009**

Alternator Freewheel Clutch	1.4 HDi		<b>F5-1046</b>		
Alternator Freewheel Clutch	1.4 HDi		<b>F5-1048</b>		
Anti-Friction Bearing	All Models		<b>F8-3012</b>		H=20; d=66; D=100
Repair Kit, wheel suspension	All Models		<b>F8-6277</b>		
Engine Mounting	1.9 D		<b>F8-6500</b>		
Repair Kit, wheel suspension	All Models		<b>F8-7197</b>		

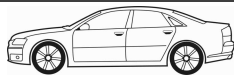

**Article Description**

**Article Nr.**
**Fitting Position**

<b>206 Van</b>			<b>04/1999 → 03/2009</b>		
Repair Kit, wheel suspension	All Models		<b>G8-197</b>		
Repair Kit, wheel suspension	All Models		<b>G8-277</b>		
Bellow, steering	All Models	with clamps;	<b>LM-10010S</b>		d1=16; d2=49; L [mm]=200
<b>206 Saloon</b>			<b>03/2007 →</b>		
Alternator Freewheel Clutch	1.4 HDi eco 70		<b>F5-1046</b>		
Alternator Freewheel Clutch	1.4 HDi eco 70		<b>F5-1048</b>		
Anti-Friction Bearing	All Models		<b>F8-3012</b>		H=20; d=66; D=100
Rubber Buffer, suspension	1.6 16V		<b>F8-6063</b>		H=73
Repair Kit, wheel suspension	All Models		<b>F8-6277</b>		
Belt Pulley, crankshaft	1.4, 1.6 16V	Number of Ribs: 5; Parameter: 6PK	<b>F8-6394</b>		H=25; d=44.05; Mounting points diam.[mm]=9; D=148; D1=142.9
Repair Kit, wheel suspension	All Models		<b>F8-7197</b>		
Repair Kit, wheel suspension	All Models		<b>G8-197</b>		
Repair Kit, wheel suspension	All Models		<b>G8-277</b>		
Bellow, steering	All Models	with clamps;	<b>LM-10010S</b>		d1=16; d2=49; L [mm]=200
Bellow, steering	All Models	; ; with clamps;	<b>LM-10040S</b>		d1=17; d2=60; L [mm]=183
<b>206+ (T3E)</b>			<b>01/2009 →</b>		
Alternator Freewheel Clutch	1.4 HDi eco 70		<b>F5-1046</b>		
Alternator Freewheel Clutch	1.4 HDi eco 70		<b>F5-1048</b>		
Anti-Friction Bearing	1.1, 1.4 HDi eco 70, 1.4 i		<b>F8-3012</b>		H=20; d=66; D=100
Repair Kit, wheel suspension	1.1, 1.4 HDi eco 70, 1.4 i		<b>F8-6277</b>		
Belt Pulley, crankshaft	1.1, 1.4 i	Number of Ribs: 5; Parameter: 6PK	<b>F8-6394</b>		H=25; d=44.05; Mounting points diam.[mm]=9; D=148; D1=142.9
Repair Kit, wheel suspension	1.1, 1.4 HDi eco 70, 1.4 i		<b>F8-7197</b>		
Repair Kit, wheel suspension	1.1, 1.4 HDi eco 70, 1.4 i		<b>G8-197</b>		
Repair Kit, wheel suspension	1.1, 1.4 HDi eco 70, 1.4 i		<b>G8-277</b>		
Bellow, steering	1.1, 1.4 HDi eco 70, 1.4 i	; ; with clamps;	<b>LM-10040S</b>		d1=17; d2=60; L [mm]=183
<b>207 (WA_, WC_)</b>			<b>02/2006 →</b>		
Alternator Freewheel Clutch	1.4 HDi, 1.6 HDi		<b>F5-1046</b>		
Alternator Freewheel Clutch	1.4 HDi, 1.6 HDi		<b>F5-1048</b>		
Alternator Freewheel Clutch	1.4 16V, 1.6 16V RC, 1.6 16V Turbo, 1.6 16V VTi		<b>F5-1113</b>		
Alternator Freewheel Clutch	1.4 16V, 1.6 16V RC, 1.6 16V Turbo, 1.6 16V VTi		<b>F5-1132</b>		
Anti-Friction Bearing	1.4, 1.4 16V, 1.4 HDi, 1.6 16V, 1.6 16V RC, 1.6 16V Turbo, 1.6 16V VTi, 1.6 HDi, 1.6 HDi 110		<b>F8-3012</b>		H=20; d=66; D=100
Belt Pulley, crankshaft	1.4, 1.4 16V, 1.6 16V	Number of Ribs: 5; Parameter: 6PK	<b>F8-6394</b>		H=25; d=44.05; Mounting points diam.[mm]=9; D=148; D1=142.9

<b>F5-1046</b>	<b>F5-1048</b>	<b>F5-1113</b>	<b>F5-1132</b>	<b>F8-3012</b>	<b>F8-6063</b>	<b>F8-6277</b>
Ref.Nr.: 30667687	Ref.Nr.: 77363468	Ref.Nr.: 12317576515	Ref.Nr.:	Ref.Nr.: 503527	Ref.Nr.: 5033.58	Ref.Nr.: 5174.05
<b>F8-6394</b>	<b>F8-6562</b>	<b>F8-7197</b>	<b>G8-197</b>	<b>G8-277</b>	<b>LM-10010S</b>	<b>LM-10040S</b>
Ref.Nr.: 0515.R8	Ref.Nr.: 5033.75	Ref.Nr.: 5132.72	Ref.Nr.: 5131.A6	Ref.Nr.: 5174.05	Ref.Nr.: 4066.56	Ref.Nr.: 4066.82

**Article Description****Article Nr.****Fitting Position**

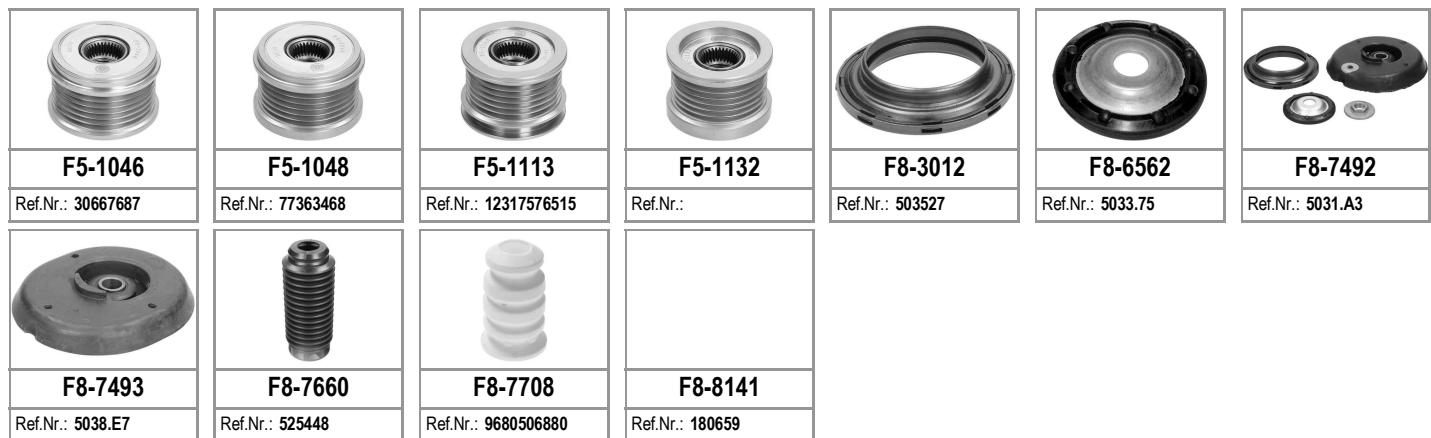
<b>207 (WA, WC)</b>			<b>02/2006 →</b>		
Spring Cap	1.4, 1.4 16V, 1.4 Bioflex, 1.4 HDi, 1.6 16V, 1.6 16V RC, 1.6 16V Turbo, 1.6 16V VTi, 1.6 Flex, 1.6 HDi, 1.6 HDi 110		<b>F8-6562</b>		
Repair Kit, suspension strut	1.4, 1.4 16V, 1.4 Bioflex, 1.4 HDi, 1.6 16V, 1.6 16V RC, 1.6 16V Turbo, 1.6 16V VTi, 1.6 Flex, 1.6 HDi, 1.6 HDi 110	<b>ST</b>	<b>F8-7492</b>		
Top Strut Mounting	1.4, 1.4 16V, 1.4 Bioflex, 1.4 HDi, 1.6 16V, 1.6 16V RC, 1.6 16V Turbo, 1.6 16V VTi, 1.6 Flex, 1.6 HDi, 1.6 HDi 110	; <b>ST</b>	<b>F8-7493</b>	⊕ ⊕	
Protective Cap/Bellow, shock absorber	1.4, 1.4 16V, 1.4 Bioflex, 1.4 HDi, 1.6 16V, 1.6 16V RC, 1.6 16V Turbo, 1.6 16V VTi, 1.6 Flex, 1.6 HDi, 1.6 HDi 110	<b>ST</b>	<b>F8-7660</b>	⊕ ⊕	H=190
Rubber Buffer, suspension	1.4 16V, 1.4 HDi, 1.6 16V, 1.6 16V RC, 1.6 16V VTi, 1.6 HDi, 1.6 HDi 110	<b>ST</b>	<b>F8-7708</b>		H=94
Engine Mounting	1.4, 1.4 16V, 1.4 HDi, 1.6 16V, 1.6 16V VTi		<b>F8-8141</b>		
<b>207 CC (WD)</b>			<b>02/2007 →</b>		
Alternator Freewheel Clutch	1.6 HDi		<b>F5-1046</b>		
Alternator Freewheel Clutch	1.6 HDi		<b>F5-1048</b>		
Alternator Freewheel Clutch	1.6 16V, 1.6 16V Turbo		<b>F5-1113</b>		
Alternator Freewheel Clutch	1.6 16V, 1.6 16V Turbo		<b>F5-1132</b>		
Anti-Friction Bearing	1.6 16V, 1.6 16V Turbo, 1.6 HDi		<b>F8-3012</b>	⊕ ⊕	H=20; d=66; D=100
Spring Cap	1.6 16V, 1.6 16V Turbo, 1.6 HDi		<b>F8-6562</b>		
Repair Kit, suspension strut	1.6 16V, 1.6 16V Turbo, 1.6 HDi	<b>ST</b>	<b>F8-7492</b>		
Top Strut Mounting	1.6 16V, 1.6 16V Turbo, 1.6 HDi	; <b>ST</b>	<b>F8-7493</b>	⊕ ⊕	
Protective Cap/Bellow, shock absorber	1.6 16V, 1.6 16V Turbo, 1.6 HDi	<b>ST</b>	<b>F8-7660</b>	⊕ ⊕	H=190
Rubber Buffer, suspension	1.6 16V, 1.6 HDi	<b>ST</b>	<b>F8-7708</b>		H=94
Engine Mounting	1.6 16V		<b>F8-8141</b>		
<b>207 Saloon</b>			<b>12/2007 →</b>		
Anti-Friction Bearing	1.4, 1.4 Bioflex, 1.6 Bioflex		<b>F8-3012</b>	⊕ ⊕	H=20; d=66; D=100
Spring Cap	1.4, 1.4 Bioflex, 1.6 Bioflex		<b>F8-6562</b>		
Repair Kit, suspension strut	1.4, 1.4 Bioflex, 1.6 Bioflex	<b>ST</b>	<b>F8-7492</b>		
Top Strut Mounting	1.4, 1.4 Bioflex, 1.6 Bioflex	; <b>ST</b>	<b>F8-7493</b>	⊕ ⊕	
Protective Cap/Bellow, shock absorber	1.4, 1.4 Bioflex, 1.6 Bioflex	<b>ST</b>	<b>F8-7660</b>	⊕ ⊕	H=190
Rubber Buffer, suspension	1.6 Bioflex	<b>ST</b>	<b>F8-7708</b>		H=94
Engine Mounting	1.4		<b>F8-8141</b>		
<b>207 SW (WK)</b>			<b>02/2007 →</b>		
Alternator Freewheel Clutch	1.6 HDi		<b>F5-1046</b>		



Article Description



Article Nr.

Fitting Position



207 SW (WK_)			02/2007 →		
Alternator Freewheel Clutch	1.6 HDi		F5-1048		
Alternator Freewheel Clutch	1.4 16V, 1.6 16V, 1.6 16V RC		F5-1113		
Alternator Freewheel Clutch	1.4 16V, 1.6 16V, 1.6 16V RC		F5-1132		
Anti-Friction Bearing	1.4, 1.4 16V, 1.6 16V, 1.6 16V RC, 1.6 HDi		F8-3012		H=20; d=66; D=100
Belt Pulley, crankshaft	1.4	Number of Ribs: 5; Parameter: 6PK	F8-6394		H=25; d=44.05; Mounting points diam.[mm]=9; D=148; D1=142.9
Spring Cap	1.4, 1.4 16V, 1.6 16V, 1.6 16V RC, 1.6 HDi		F8-6562		
Repair Kit, suspension strut	1.4, 1.4 16V, 1.6 16V, 1.6 16V RC, 1.6 HDi	ST	F8-7492		
Top Strut Mounting	1.4, 1.4 16V, 1.6 16V, 1.6 16V RC, 1.6 HDi	; ST	F8-7493		
Protective Cap/Bellow, shock absorber	1.4, 1.4 16V, 1.6 16V, 1.6 16V RC, 1.6 HDi	ST	F8-7660		H=190
Rubber Buffer, suspension	1.4 16V, 1.6 16V, 1.6 16V RC, 1.6 HDi	ST	F8-7708		H=94
Engine Mounting	1.4, 1.4 16V, 1.6 16V		F8-8141		
207 Van			04/2007 →		
Alternator Freewheel Clutch	1.4 HDi, 1.6 HDi		F5-1046		
Alternator Freewheel Clutch	1.4 HDi, 1.6 HDi		F5-1048		
Anti-Friction Bearing	1.4 HDi, 1.6 HDi		F8-3012		H=20; d=66; D=100
Spring Cap	1.4 HDi, 1.6 HDi		F8-6562		
Repair Kit, suspension strut	1.4 HDi, 1.6 HDi	ST	F8-7492		
Top Strut Mounting	1.4 HDi, 1.6 HDi	; ST	F8-7493		
Protective Cap/Bellow, shock absorber	1.4 HDi, 1.6 HDi	ST	F8-7660		H=190
Engine Mounting	1.4 HDi		F8-8141		
208			03/2012 →		
Alternator Freewheel Clutch	1.4, 1.6		F5-1113		
Alternator Freewheel Clutch	1.4, 1.6		F5-1132		
Spring Cap	1.0, 1.2, 1.4, 1.4 HDi, 1.6, 1.6 GTi, 1.6 HDi		F8-6562		
Protective Cap/Bellow, shock absorber	1.0, 1.2, 1.4, 1.4 HDi, 1.6, 1.6 GTi, 1.6 HDi	ST	F8-7660		H=190
Rubber Buffer, suspension	1.0, 1.2, 1.4, 1.4 HDi, 1.6, 1.6 HDi	for OE: 9676408280	F8-7849		H=85
Engine Mounting	1.4, 1.4 HDi, 1.6		F8-8141		
301			11/2012 →		
Belt Pulley, crankshaft	1.6 VTi 115	Number of Ribs: 5; Parameter: 6PK	F8-6394		H=25; d=44.05; Mounting points diam.[mm]=9; D=148; D1=142.9
305 (581A)			11/1977 → 09/1982		
Dust Cover Kit, shock absorber	1.3, 1.5, 1.5 Diesel	ch.8987001→; 07/1982 →	AK-735010		

<b>AK-735010</b>	<b>F5-1046</b>	<b>F5-1048</b>	<b>F5-1113</b>	<b>F5-1132</b>	<b>F8-3012</b>	<b>F8-6394</b>
Ref.Nr.:	Ref.Nr.: 30667687	Ref.Nr.: 77363468	Ref.Nr.: 12317576515	Ref.Nr.:	Ref.Nr.: 503527	Ref.Nr.: 0515.R8
<b>F8-6562</b>	<b>F8-7492</b>	<b>F8-7493</b>	<b>F8-7660</b>	<b>F8-7708</b>	<b>F8-7849</b>	<b>F8-8141</b>
Ref.Nr.: 5033.75	Ref.Nr.: 5031.A3	Ref.Nr.: 5038.E7	Ref.Nr.: 525448	Ref.Nr.: 9680506880	Ref.Nr.: 5033E3	Ref.Nr.: 180659

**Article Description****Article Nr.****Fitting Position**

<b>305 Estate (581D)</b>			<b>08/1980 → 09/1982</b>		
Dust Cover Kit, shock absorber	All Models	ch.8987001→; 07/1982 →	<b>AK-735010</b>		
<b>305 Mk II (581M)</b>			<b>10/1982 → 07/1990</b>		
Dust Cover Kit, shock absorber	1.3, 1.5, 1.6, 1.9 D		<b>AK-735010</b>		
Dust Cover Kit, shock absorber	1.6	ch.9524001→	<b>AK-735010</b>		
Dust Cover Kit, shock absorber	1.9	ch.9370001→	<b>AK-735010</b>		
Anti-Friction Bearing	1.3, 1.5, 1.6, 1.9, 1.9 D	01/1984 →	<b>F8-3012</b>		H=20; d=66; D=100
Anti-Friction Bearing	1.5, 1.6, 1.9		<b>F8-3012</b>		H=20; d=66; D=100
Top Strut Mounting	1.3, 1.5, 1.6, 1.9, 1.9 D		<b>F8-5520</b>		
Stabiliser Mounting	1.3, 1.5		<b>F8-7212</b>		D=21
Control Arm-Trailing Arm Bush	1.3, 1.5, 1.6, 1.9, 1.9 D		<b>F8-7994</b>		H=40; d=16
<b>305 Mk II Estate (581E)</b>			<b>10/1982 → 12/1988</b>		
Dust Cover Kit, shock absorber	1.3, 1.5, 1.6, 1.9, 1.9 Diesel		<b>AK-735010</b>		
Anti-Friction Bearing	1.3, 1.5, 1.6, 1.9 Diesel	01/1984 →	<b>F8-3012</b>		H=20; d=66; D=100
Anti-Friction Bearing	1.5, 1.6, 1.9		<b>F8-3012</b>		H=20; d=66; D=100
Top Strut Mounting	1.3, 1.5, 1.6, 1.9, 1.9 Diesel		<b>F8-5520</b>		
Stabiliser Mounting	1.3, 1.5		<b>F8-7212</b>		D=21
Control Arm-Trailing Arm Bush	1.3, 1.5, 1.6, 1.9, 1.9 Diesel		<b>F8-7994</b>		H=40; d=16
<b>306 (7B, N3, N5)</b>			<b>02/1994 → 05/2001</b>		
Dust Cover Kit, shock absorber	1.1, 1.4 SL, 1.6, 1.6 SR, 1.8 16V, 1.8 ST, 1.9 D, 1.9 SLD, 1.9 SRDT, 2.0, 2.0 HDI 90, 2.0 S16, 2.0 ST		<b>AK-735010</b>		
Alternator Freewheel Clutch	2.0 HDI 90		<b>F5-1020</b>		
Alternator Freewheel Clutch	2.0 HDI 90		<b>F5-1046</b>		
Anti-Friction Bearing	All Models		<b>F8-3012</b>		H=20; d=66; D=100
Stabiliser Mounting	1.1, 1.4 SL, 1.6, 1.6 SR, 1.8 16V, 1.8 ST, 1.9 D, 1.9 SLD, 1.9 SRDT, 2.0, 2.0 HDI 90, 2.0 S16, 2.0 ST		<b>F8-5062</b>		d=17
Stabiliser Mounting	1.1, 1.4 SL, 1.6, 1.6 SR, 1.8 16V, 1.8 ST, 1.9 D, 1.9 SLD, 1.9 SRDT, 2.0, 2.0 HDI 90, 2.0 S16, 2.0 ST		<b>F8-5077</b>		d=18
Stabiliser Mounting	1.9 D		<b>F8-5092</b>		d=24
Stabiliser Mounting	1.1, 1.4 SL, 1.6, 1.6 SR, 1.8 16V, 1.8 ST, 1.9 D, 1.9 SLD, 1.9 SRDT, 2.0, 2.0 HDI 90, 2.0 S16, 2.0 ST		<b>F8-5213</b>		D=21; d=21
Stabiliser Mounting	1.9 D, 2.0 S16		<b>F8-5213</b>		d=21
Control Arm-Trailing Arm Bush	1.1, 1.4 SL, 1.6, 1.6 SR, 1.8 16V, 1.8 ST, 1.9 D, 1.9 SLD, 1.9 SRDT, 2.0, 2.0 HDI 90, 2.0 S16, 2.0 ST		<b>F8-5248</b>		
Mounting, axle beam	1.1, 1.4 SL, 1.6, 1.6 SR, 1.8 16V, 1.8 ST, 1.9 D, 1.9 SLD, 1.9 SRDT, 2.0, 2.0 HDI 90, 2.0 S16, 2.0 ST		<b>F8-5351</b>		

<b>AK-735010</b>	<b>F5-1020</b>	<b>F5-1046</b>	<b>F8-3012</b>	<b>F8-5062</b>	<b>F8-5077</b>	<b>F8-5092</b>
Ref.Nr.:	Ref.Nr.: 31771-68D01	Ref.Nr.: 30667687	Ref.Nr.: 503527	Ref.Nr.: 5094.63	Ref.Nr.: 9615871880	Ref.Nr.: 1305782080
<b>F8-5213</b>	<b>F8-5248</b>	<b>F8-5351</b>	<b>F8-5352</b>	<b>F8-5520</b>	<b>F8-7212</b>	<b>F8-7994</b>
Ref.Nr.: 5094.65	Ref.Nr.: 3523.59	Ref.Nr.: 513170	Ref.Nr.: 513169	Ref.Nr.: 503518	Ref.Nr.: 5094.53	Ref.Nr.: 3523.14

Article Description



Article Nr.

Fitting Position



### 306 (7B, N3, N5)

02/1994 → 05/2001

Mounting, axle beam	1.1, 1.4 SL, 1.6, 1.6 SR, 1.8 16V, 1.8 ST, 1.9 D, 1.9 SLD, 1.9 SRDT, 2.0, 2.0 HDI 90, 2.0 S16, 2.0 ST		F8-5352		
Control Arm-/Trailing Arm Bush	1.1, 1.4 SL, 1.6, 1.6 SR, 1.8 16V, 1.8 ST, 1.9 D, 1.9 SLD, 1.9 SRDT, 1.9 STD, 2.0, 2.0 HDI 90, 2.0 S16, 2.0 ST		F8-5355		
Bellow, driveshaft	1.1, 1.4 SL	Transmission Type: MA	F8-5356		D1=72; D219; L=172
Bellow, driveshaft	1.6 SR	Transmission Type: MAR	F8-5356		D1=72; D219; L=172
Bellow, driveshaft	1.8 16V, 1.8 ST	Transmission Type: BE3	F8-5356		D1=72; D219; L=172
Bellow, driveshaft	1.9 D		F8-5356		D1=72; D219; L=172
Engine Mounting	1.6 SR		F8-5357		
Engine Mounting	1.8 ST		F8-5357		
Engine Mounting	1.9 D	ch.→O06884;	F8-5357		
Engine Mounting	1.9 SLD, 1.9 SRDT, 1.9 STD	Orga.→06884	F8-5357		
Engine Mounting	2.0 S16, 2.0 ST		F8-5357		
Engine Mounting	1.6, 1.6 SR, 1.8 ST		F8-5358		
Engine Mounting	1.8 16V		F8-5359		
Engine Mounting	1.8 ST		F8-5359		
Engine Mounting	1.9 D	Orga.08240→	F8-5359		
Engine Mounting	1.9 SRDT, 2.0	05/1997 →	F8-5359		
Engine Mounting	2.0 HDI 90		F8-5359		
Mounting, axle beam	1.1, 1.4 SL, 1.6, 1.6 SR, 1.8 16V, 1.8 ST, 1.9 D, 1.9 SLD, 1.9 SRDT, 2.0, 2.0 HDI 90, 2.0 S16, 2.0 ST		F8-5363		
Top Strut Mounting	1.1, 1.4 SL, 1.6, 1.6 SR, 1.8 16V, 1.8 ST, 1.9 D, 1.9 SLD, 1.9 SRDT, 2.0, 2.0 HDI 90, 2.0 S16, 2.0 ST		F8-5364		
Engine Mounting	1.1, 1.4 SL, 1.6, 1.6 SR		F8-5375		H=34; d=12; D=30
Top Strut Mounting	1.1, 1.4 SL, 1.6, 1.6 SR, 1.8 16V, 1.8 ST, 1.9 D, 1.9 SLD, 1.9 SRDT, 2.0, 2.0 HDI 90, 2.0 S16, 2.0 ST		F8-5516		
Top Strut Mounting	1.1, 1.4 SL, 1.6 SR, 1.8 ST, 1.9 SLD, 1.9 SRDT, 2.0 S16, 2.0 ST		F8-5517		
Engine Mounting	1.8 ST		F8-5556		
Engine Mounting	1.1, 1.8 ST, 1.9 SRDT, 2.0, 2.0 HDI 90, 2.0 ST		F8-5568		
Engine Mounting	1.4 SL	TU3MC	F8-5568		
Engine Mounting	1.6 SR, 1.8 16V, 2.0 S16		F8-5568		
Belt Pulley, crankshaft	1.9 D	DW8B; Orga.09520→	F8-5636		d=30
Belt Pulley, crankshaft	2.0 HDI 90		F8-5636		d=30
Belt Pulley, crankshaft	1.9 D, 1.9 SLD, 1.9 SRDT, 1.9 STD	Number of Ribs: 6	F8-5643		Belt Pulley Ø [mm]=156; W=44
Belt Pulley, crankshaft	1.9 D	ch.→O09519;	F8-5659		

<b>F8-5352</b>	<b>F8-5355</b>	<b>F8-5356</b>	<b>F8-5357</b>	<b>F8-5358</b>	<b>F8-5359</b>	<b>F8-5363</b>
Ref.Nr.: 513169	Ref.Nr.: 3520.H5S1	Ref.Nr.: 328769	Ref.Nr.: 1844.47	Ref.Nr.: 184373	Ref.Nr.: 182723	Ref.Nr.: 5131.71
<b>F8-5364</b>	<b>F8-5375</b>	<b>F8-5516</b>	<b>F8-5517</b>	<b>F8-5556</b>	<b>F8-5568</b>	<b>F8-5636</b>
Ref.Nr.: 503821	Ref.Nr.: 180906	Ref.Nr.: 503824	Ref.Nr.: 5038.23	Ref.Nr.: 1843.95	Ref.Nr.: 184425	Ref.Nr.: 0515P2
<b>F8-5643</b>	<b>F8-5659</b>	<b>F8-6064</b>				
Ref.Nr.: 96089 38980	Ref.Nr.: 0515Q6	Ref.Nr.: 5033.26				

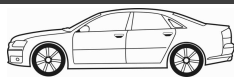

**Article Description****Article Nr.****Fitting Position**

<b>306 (7B, N3, N5)</b>		<b>02/1994 → 05/2001</b>		
Rubber Buffer, suspension	1.1, 1.4 SL, 1.6, 1.6 SR, 1.8 16V, 1.8 ST, 1.9 D, 1.9 SLD, 1.9 SRDT, 1.9 STD, 2.0, 2.0 HDI 90, 2.0 S16, 2.0 ST		F8-6064	L=79
Stabiliser Mounting	1.9 D, 2.0 HDI 90		F8-6128	d=22
Stabiliser Mounting	1.1, 1.4 SL, 1.6, 1.6 SR, 1.8 16V, 1.8 ST, 1.9 D, 1.9 SLD, 1.9 SRDT, 1.9 STD, 2.0, 2.0 HDI 90, 2.0 S16, 2.0 ST		F8-6129  ⊕ ⊕	d=19
Engine Mounting	1.8 16V, 1.8 ST, 1.9 D, 1.9 SLD, 1.9 SRDT, 1.9 STD, 2.0, 2.0 HDI 90, 2.0 S16, 2.0 ST		F8-6236  ⊕	H1=53; H2=40; d=10; D=70
Engine Mounting	1.8 16V, 1.8 ST, 1.9 D, 1.9 SLD, 1.9 SRDT, 1.9 STD, 2.0, 2.0 HDI 90, 2.0 S16, 2.0 ST		F8-6237	
Repair Kit, wheel suspension	All Models		F8-6272	
Top Strut Mounting	1.1, 1.4 SL, 1.6, 1.6 SR, 1.8 16V, 1.8 ST, 1.9 D, 1.9 SLD, 1.9 SRDT, 2.0, 2.0 HDI 90, 2.0 S16, 2.0 ST		F8-6296	
Top Strut Mounting	1.1, 1.4 SL, 1.6, 1.6 SR, 1.8 16V, 1.8 ST, 1.9 D, 1.9 SLD, 1.9 SRDT, 2.0, 2.0 HDI 90, 2.0 S16, 2.0 ST		F8-6297	
Engine Mounting	1.1		F8-6487 ⊕	
Engine Mounting	1.4 SL	TU3JP, TU3MC	F8-6487 ⊕	
Engine Mounting	1.6		F8-6497 ⊕	
Engine Mounting	1.6 SR	01/1997 →;	F8-6497 ⊕	
Engine Mounting	1.8		F8-6500 ⊕	
Engine Mounting	1.8 16V, 2.0 S16		F8-6500 ⊕	
Engine Mounting	1.8 ST	XU7JP;	F8-6500 ⊕	
Engine Mounting	1.9 D, 1.9 SLD, 1.9 STD, 2.0, 2.0 HDI 90		F8-6500 ⊕	
Engine Mounting	1.9 SRDT	XUD9TE	F8-6500 ⊕	
Engine Mounting	2.0 ST	XU10J2	F8-6500 ⊕	
Mounting, automatic transmission	1.1, 1.6, 1.6 SR		F8-6505 ⊕	
Mounting, automatic transmission	1.4 SL	TU3JP, TU3M, TU3MC	F8-6505 ⊕	
Belt Pulley, crankshaft	1.8 16V, 2.0	Number of Ribs: 6	F8-7083	Belt Pulley Ø [mm]=127; Mounting points diam.[mm]=30; W=38
Belt Pulley, crankshaft	1.8 ST, 2.0 ST	08/1994 →; Number of Ribs: 6	F8-7084	Belt Pulley Ø [mm]=127; Mounting points diam.[mm]=30; W=45
Stabiliser Mounting	1.9 SRDT		F8-7943  ⊕ ⊕	
Repair Kit, wheel suspension	All Models		G8-272	
Bellow, steering	1.1, 1.4 SL, 1.6, 1.6 SR, 1.8, 1.8 16V, 1.8 ST, 1.9 D, 1.9 SLD, 1.9 SRDT, 1.9 STD, 2.0, 2.0 HDI 90, 2.0 S16, 2.0 ST	; Orga.→06656; with clamps;	LM-10004S  ⊕	d1=10; d2=40; L [mm]=175

<b>F8-6064</b>	<b>F8-6128</b>	<b>F8-6129</b>	<b>F8-6236</b>	<b>F8-6237</b>	<b>F8-6272</b>	<b>F8-6296</b>
Ref.Nr.: 5033.26	Ref.Nr.: 5094.77	Ref.Nr.: 509466	Ref.Nr.: 1809.21	Ref.Nr.: 1809.22	Ref.Nr.: 9556384280	Ref.Nr.: 503824
<b>F8-6297</b>	<b>F8-6487</b>	<b>F8-6497</b>	<b>F8-6500</b>	<b>F8-6505</b>	<b>F8-7083</b>	<b>F8-7084</b>
Ref.Nr.: 503527	Ref.Nr.: 184472	Ref.Nr.: 1844.75	Ref.Nr.: 1844.36	Ref.Nr.: 1844.51	Ref.Nr.: 0515.K6	Ref.Nr.: 0515.H6
<b>F8-7943</b>	<b>G8-272</b>	<b>LM-10004S</b>				
Ref.Nr.: 509479	Ref.Nr.: 5132.49	Ref.Nr.: 7910030073				

Article Description

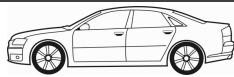

Article Nr.

Fitting Position



306 (7B, N3, N5)		02/1994 → 05/2001		
Bellow, steering	1.1, 1.4 SL, 1.6, 1.6 SR, 1.8, 1.8 16V, 1.8 ST, 1.9 D, 1.9 SLD, 1.9 SRDT, 1.9 STD, 2.0, 2.0 HDI 90, 2.0 S16, 2.0 ST	with clamps;	LM-10004S	d1=10; d2=40; L [mm]=175
Bellow, steering	1.1	TU1M; Orga.→06657; with clamps;	LM-10039S	d1=40; d2=40; L [mm]=115
Bellow, steering	1.1	TU1M; with clamps;	LM-10039S	d1=40; d2=40; L [mm]=115
Bellow, steering	1.4 SL	TU32; Orga.→06657; with clamps;	LM-10039S	d1=40; d2=40; L [mm]=115
Bellow, steering	1.4 SL	TU32; with clamps;	LM-10039S	d1=40; d2=40; L [mm]=115
Bellow, steering	1.4 SL	TU3JP; Orga.→06657; with clamps;	LM-10039S	d1=40; d2=40; L [mm]=115
Bellow, steering	1.4 SL	TU3JP; with clamps;	LM-10039S	d1=40; d2=40; L [mm]=115
Bellow, steering	1.4 SL	TU3M; Orga.→06657; with clamps;	LM-10039S	d1=40; d2=40; L [mm]=115
Bellow, steering	1.4 SL	TU3M; with clamps;	LM-10039S	d1=40; d2=40; L [mm]=115
Bellow, steering	1.4 SL	TU3MC; Orga.→06657; with clamps;	LM-10039S	d1=40; d2=40; L [mm]=115
Bellow, steering	1.4 SL	TU3MC; with clamps;	LM-10039S	d1=40; d2=40; L [mm]=115
Bellow, steering	1.6 SR, 1.8, 1.9 D, 1.9 SLD, 1.9 STD, 2.0 S16	Orga.→06657; with clamps;	LM-10039S	d1=40; d2=40; L [mm]=115
Bellow, steering	1.6, 1.6 SR, 1.8, 1.8 16V, 1.9 D, 1.9 SLD, 1.9 STD, 2.0, 2.0 HDI 90, 2.0 S16	with clamps;	LM-10039S	d1=40; d2=40; L [mm]=115
Bellow, steering	1.8 ST	XU7JP; Orga.→06657; with clamps;	LM-10039S	d1=40; d2=40; L [mm]=115
Bellow, steering	1.8 ST	XU7JP; with clamps;	LM-10039S	d1=40; d2=40; L [mm]=115
Bellow, steering	1.9 SRDT	XUD9TE; Orga.→06657; with clamps;	LM-10039S	d1=40; d2=40; L [mm]=115
Bellow, steering	1.9 SRDT	XUD9TE; with clamps;	LM-10039S	d1=40; d2=40; L [mm]=115
Bellow, steering	2.0 ST	XU10J2; Orga.→06657; with clamps;	LM-10039S	d1=40; d2=40; L [mm]=115
Bellow, steering	2.0 ST	XU10J2; with clamps;	LM-10039S	d1=40; d2=40; L [mm]=115
Bellow, steering	1.1, 1.4 SL, 1.9 D, 1.9 SLD, 1.9 SRDT, 2.0, 2.0 HDI 90, 2.0 S16, 2.0 ST	with clamps	LM-10054S	d1=11; d2=39; L [mm]=66
306 Break (7E, N3, N5)		02/1997 → 04/2002		
Dust Cover Kit, shock absorber	1.4, 1.6, 1.8, 1.8 16V, 1.9 D, 1.9 TD, 2.0, 2.0 HDI 90		AK-735010	
Alternator Freewheel Clutch	2.0 HDI 90		F5-1020	
Alternator Freewheel Clutch	2.0 HDI 90		F5-1046	
Anti-Friction Bearing	All Models		F8-3012	H=20; d=66; D=100
Stabiliser Mounting	1.4, 1.6, 1.8, 1.8 16V, 1.9 D, 1.9 TD, 2.0, 2.0 HDI 90		F8-5062	d=17
Stabiliser Mounting	1.4, 1.6, 1.8, 1.8 16V, 1.9 D, 1.9 TD, 2.0, 2.0 HDI 90		F8-5077	d=18
Stabiliser Mounting	1.4, 1.6, 1.8, 1.8 16V, 1.9 D, 1.9 TD, 2.0, 2.0 HDI 90		F8-5213	D=21; d=21



**Article Description****Article Nr.****Fitting Position**

<b>306 Break (7E, N3, N5)</b>			<b>02/1997 → 04/2002</b>		
Stabiliser Mounting	1.9 D		<b>F8-5213</b>		d=21
Control Arm-/Trailing Arm Bush	1.4, 1.6, 1.8, 1.8 16V, 1.9 D, 1.9 TD, 2.0, 2.0 HDI 90		<b>F8-5248</b>		
Mounting, axle beam	1.4, 1.6, 1.8, 1.8 16V, 1.9 D, 1.9 TD, 2.0, 2.0 HDI 90		<b>F8-5351</b>		
Mounting, axle beam	1.4, 1.6, 1.8, 1.8 16V, 1.9 D, 1.9 TD, 2.0, 2.0 HDI 90		<b>F8-5352</b>		
Control Arm-/Trailing Arm Bush	All Models		<b>F8-5355</b>		
Bellow, driveshaft	1.4	Transmission Type: MA	<b>F8-5356</b>		D1=72; D219; L=172
Bellow, driveshaft	1.6	Transmission Type: MAR	<b>F8-5356</b>		D1=72; D219; L=172
Bellow, driveshaft	1.8, 1.8 16V	Transmission Type: BE3	<b>F8-5356</b>		D1=72; D219; L=172
Bellow, driveshaft	1.9 D		<b>F8-5356</b>		D1=72; D219; L=172
Engine Mounting	1.9 D	Orga. →08239	<b>F8-5357</b>		
Engine Mounting	1.9 D, 1.9 TD	Orga. →06884	<b>F8-5357</b>		
Engine Mounting	1.6, 1.8		<b>F8-5358</b>		
Engine Mounting	1.8		<b>F8-5359</b>		
Engine Mounting	1.8 16V		<b>F8-5359</b>		
Engine Mounting	1.9 D	Orga.08240→	<b>F8-5359</b>		
Engine Mounting	1.9 TD, 2.0 HDI 90		<b>F8-5359</b>		
Engine Mounting	2.0	05/1997 →	<b>F8-5359</b>		
Mounting, axle beam	1.4, 1.6, 1.8, 1.8 16V, 1.9 D, 1.9 TD, 2.0, 2.0 HDI 90		<b>F8-5363</b>		
Top Strut Mounting	1.4, 1.6, 1.8, 1.8 16V, 1.9 D, 1.9 TD, 2.0, 2.0 HDI 90		<b>F8-5364</b>		
Engine Mounting	1.4, 1.6		<b>F8-5375</b>		H=34; d=12; D=30
Top Strut Mounting	1.4, 1.6, 1.8, 1.8 16V, 1.9 D, 1.9 TD, 2.0, 2.0 HDI 90		<b>F8-5516</b>		
Top Strut Mounting	1.4, 1.6		<b>F8-5517</b>		
Engine Mounting	1.8		<b>F8-5556</b>		
Engine Mounting	1.6		<b>F8-5568</b>		
Engine Mounting	1.8, 1.8 16V, 2.0, 2.0 HDI 90		<b>F8-5568</b>		
Belt Pulley, crankshaft	1.9 D	Orga.09520→	<b>F8-5636</b>		d=30
Belt Pulley, crankshaft	2.0 HDI 90		<b>F8-5636</b>		d=30
Belt Pulley, crankshaft	1.9 D, 1.9 TD	Number of Ribs: 6	<b>F8-5643</b>		Belt Pulley Ø [mm]=156; W=44
Belt Pulley, crankshaft	1.9 D	ch.→O09519;	<b>F8-5659</b>		
Rubber Buffer, suspension	1.6, 1.8, 1.8 16V, 1.9 D, 1.9 TD, 2.0, 2.0 HDI 90		<b>F8-6064</b>		L=79
Stabiliser Mounting	1.9 D, 2.0 HDI 90		<b>F8-6128</b>		d=22
Stabiliser Mounting	All Models		<b>F8-6129</b>		d=19
Engine Mounting	1.8, 1.8 16V, 1.9 D, 1.9 TD, 2.0, 2.0 HDI 90		<b>F8-6236</b>		H1=53; H2=40; d=10; D=70
Engine Mounting	1.8, 1.8 16V, 1.9 D, 1.9 TD, 2.0, 2.0 HDI 90		<b>F8-6237</b>		

<b>F8-5213</b>	<b>F8-5248</b>	<b>F8-5351</b>	<b>F8-5352</b>	<b>F8-5355</b>	<b>F8-5356</b>	<b>F8-5357</b>
Ref.Nr.: 5094.65	Ref.Nr.: 3523.59	Ref.Nr.: 513170	Ref.Nr.: 513169	Ref.Nr.: 3520.H5S1	Ref.Nr.: 328769	Ref.Nr.: 1844.47
<b>F8-5358</b>	<b>F8-5359</b>	<b>F8-5363</b>	<b>F8-5364</b>	<b>F8-5375</b>	<b>F8-5516</b>	<b>F8-5517</b>
Ref.Nr.: 184373	Ref.Nr.: 182723	Ref.Nr.: 5131.71	Ref.Nr.: 503821	Ref.Nr.: 180906	Ref.Nr.: 503824	Ref.Nr.: 5038.23
<b>F8-5556</b>	<b>F8-5568</b>	<b>F8-5636</b>	<b>F8-5643</b>	<b>F8-5659</b>	<b>F8-6064</b>	<b>F8-6128</b>
Ref.Nr.: 1843.95	Ref.Nr.: 184425	Ref.Nr.: 0515P2	Ref.Nr.: 96089 38980	Ref.Nr.: 0515Q6	Ref.Nr.: 5033.26	Ref.Nr.: 5094.77

Article Description



Article Nr.

Fitting Position



**306 Break (7E, N3, N5)** 02/1997 → 04/2002

Repair Kit, wheel suspension	All Models		F8-6272		
Top Strut Mounting	1.4, 1.6, 1.8, 1.8 16V, 1.9 D, 1.9 TD, 2.0, 2.0 HDI 90		F8-6296		
Top Strut Mounting	1.4, 1.6, 1.8, 1.8 16V, 1.9 D, 1.9 TD, 2.0, 2.0 HDI 90		F8-6297		
Engine Mounting	1.4		F8-6487		
Engine Mounting	1.6		F8-6497		
Engine Mounting	1.8	XU7JP;	F8-6500		
Engine Mounting	1.8 16V		F8-6500		
Engine Mounting	1.9 D, 2.0, 2.0 HDI 90		F8-6500		
Engine Mounting	1.9 TD	XUD9TE	F8-6500		
Mounting, automatic transmission	1.4, 1.6		F8-6505		
Belt Pulley, crankshaft	1.8 16V, 2.0	Number of Ribs: 6	F8-7083		Belt Pulley Ø [mm]=127; Mounting points diam.[mm]=30; W=38
Belt Pulley, crankshaft	1.8	04/1997 →; Number of Ribs: 6	F8-7084		Belt Pulley Ø [mm]=127; Mounting points diam.[mm]=30; W=45
Stabiliser Mounting	1.9 TD		F8-7943		
Repair Kit, wheel suspension	All Models		G8-272		
Bellow, steering	1.4, 1.6, 1.8, 1.8 16V, 1.9 D, 1.9 TD, 2.0, 2.0 HDI 90	; Orga. →06656; with clamps;	LM-10004S		d1=10; d2=40; L [mm]=175
Bellow, steering	1.4, 1.6, 1.8, 1.8 16V, 1.9 D, 1.9 TD, 2.0, 2.0 HDI 90	; with clamps;	LM-10004S		d1=10; d2=40; L [mm]=175
Bellow, steering	1.4	TU3JP; with clamps;	LM-10039S		d1=40; d2=40; L [mm]=115
Bellow, steering	1.6, 1.8 16V, 1.9 D, 2.0, 2.0 HDI 90	with clamps;	LM-10039S		d1=40; d2=40; L [mm]=115
Bellow, steering	1.8	XU7JP; with clamps;	LM-10039S		d1=40; d2=40; L [mm]=115
Bellow, steering	1.9 TD	XUD9TE; with clamps;	LM-10039S		d1=40; d2=40; L [mm]=115
Bellow, steering	1.4, 1.6, 1.8, 1.8 16V, 1.9 D, 1.9 TD, 2.0, 2.0 HDI 90	with clamps	LM-10054S		d1=11; d2=39; L [mm]=66

**306 Convertible (7D, N3, N5)** 03/1994 → 04/2002

Anti-Friction Bearing	1.6, 1.8, 1.8 16V, 2.0, 2.0 16V		F8-3012		H=20; d=66; D=100
Stabiliser Mounting	1.6, 1.8, 1.8 16V, 2.0, 2.0 16V		F8-5062		d=17
Stabiliser Mounting	1.6, 1.8, 1.8 16V, 2.0, 2.0 16V		F8-5077		d=18
Stabiliser Mounting	1.6, 1.8, 1.8 16V, 2.0, 2.0 16V		F8-5213		D=21; d=21
Control Arm-/Trailing Arm Bush	1.6, 1.8, 1.8 16V, 2.0, 2.0 16V		F8-5248		
Mounting, axle beam	1.6, 1.8, 1.8 16V, 2.0, 2.0 16V		F8-5351		
Mounting, axle beam	1.6, 1.8, 1.8 16V, 2.0, 2.0 16V		F8-5352		
Control Arm-/Trailing Arm Bush	1.6, 1.8, 1.8 16V, 2.0, 2.0 16V		F8-5355		

<b>F8-3012</b>	<b>F8-5062</b>	<b>F8-5077</b>	<b>F8-5213</b>	<b>F8-5248</b>	<b>F8-5351</b>	<b>F8-5352</b>
Ref.Nr.: 503527	Ref.Nr.: 5094.63	Ref.Nr.: 9615871880	Ref.Nr.: 5094.65	Ref.Nr.: 3523.59	Ref.Nr.: 513170	Ref.Nr.: 513169
<b>F8-5355</b>	<b>F8-5356</b>	<b>F8-6272</b>	<b>F8-6296</b>	<b>F8-6297</b>	<b>F8-6487</b>	<b>F8-6497</b>
Ref.Nr.: 3520.H5S1	Ref.Nr.: 328769	Ref.Nr.: 9556384280	Ref.Nr.: 503824	Ref.Nr.: 503527	Ref.Nr.: 184472	Ref.Nr.: 1844.75
<b>F8-6500</b>	<b>F8-6505</b>	<b>F8-7083</b>	<b>F8-7084</b>	<b>F8-7943</b>	<b>G8-272</b>	<b>LM-10004S</b>
Ref.Nr.: 1844.36	Ref.Nr.: 1844.51	Ref.Nr.: 0515.K6	Ref.Nr.: 0515.H6	Ref.Nr.: 509479	Ref.Nr.: 5132.49	Ref.Nr.: 7910030073

**Article Description****Article Nr.****Fitting Position**

<b>306 Convertible (7D, N3, N5)</b>			<b>03/1994 → 04/2002</b>		
Bellow, driveshaft	1.6	Transmission Type: MAR	<b>F8-5356</b>		D1=72; D219; L=172
Bellow, driveshaft	1.8, 1.8 16V	Transmission Type: BE3	<b>F8-5356</b>		D1=72; D219; L=172
Engine Mounting	1.6		<b>F8-5357</b>		
Engine Mounting	1.8		<b>F8-5357</b>		
Engine Mounting	2.0		<b>F8-5357</b>		
Engine Mounting	1.6, 1.8		<b>F8-5358</b>		
Engine Mounting	1.8		<b>F8-5359</b>		
Engine Mounting	1.8 16V		<b>F8-5359</b>		
Engine Mounting	2.0 16V	05/1997 →	<b>F8-5359</b>		
Mounting, axle beam	1.6, 1.8, 1.8 16V, 2.0, 2.0 16V		<b>F8-5363</b>		
Top Strut Mounting	1.6, 1.8, 1.8 16V, 2.0, 2.0 16V		<b>F8-5364</b>		
Engine Mounting	1.6		<b>F8-5375</b>		H=34; d=12; D=30
Top Strut Mounting	1.6, 1.8, 1.8 16V, 2.0, 2.0 16V		<b>F8-5516</b>		
Engine Mounting	1.8		<b>F8-5556</b>		
Engine Mounting	1.8, 1.8 16V, 2.0 16V		<b>F8-5568</b>		
Rubber Buffer, suspension	1.6, 1.8, 1.8 16V, 2.0, 2.0 16V		<b>F8-6064</b>		L=79
Stabiliser Mounting	1.6, 1.8, 1.8 16V, 2.0, 2.0 16V		<b>F8-6129</b>		d=19
Engine Mounting	1.8, 1.8 16V, 2.0, 2.0 16V		<b>F8-6236</b>		H1=53; H2=40; d=10; D=70
Engine Mounting	1.8, 1.8 16V, 2.0, 2.0 16V		<b>F8-6237</b>		
Repair Kit, wheel suspension	All Models		<b>F8-6272</b>		
Top Strut Mounting	1.6, 1.8, 1.8 16V, 2.0, 2.0 16V		<b>F8-6296</b>		
Engine Mounting	1.6	01/1997 →;	<b>F8-6497</b>		
Engine Mounting	1.6		<b>F8-6497</b>		
Engine Mounting	1.8	XU7JP;	<b>F8-6500</b>		
Engine Mounting	1.8 16V		<b>F8-6500</b>		
Engine Mounting	2.0	XU10J2	<b>F8-6500</b>		
Engine Mounting	2.0 16V		<b>F8-6500</b>		
Mounting, automatic transmission	1.6		<b>F8-6505</b>		
Belt Pulley, crankshaft	1.8 16V, 2.0 16V	Number of Ribs: 6	<b>F8-7083</b>		Belt Pulley Ø [mm]=127; Mounting points diam.[mm]=30; W=38
Belt Pulley, crankshaft	1.8, 2.0	Number of Ribs: 6	<b>F8-7084</b>		Belt Pulley Ø [mm]=127; Mounting points diam.[mm]=30; W=45
Repair Kit, wheel suspension	All Models		<b>G8-272</b>		
Bellow, steering	1.6, 1.8, 1.8 16V, 2.0, 2.0 16V	; Orga.→06656; with clamps;	<b>LM-10004S</b>		d1=10; d2=40; L [mm]=175

<b>F8-5356</b>	<b>F8-5357</b>	<b>F8-5358</b>	<b>F8-5359</b>	<b>F8-5363</b>	<b>F8-5364</b>	<b>F8-5375</b>
Ref.Nr.: 328769	Ref.Nr.: 1844.47	Ref.Nr.: 184373	Ref.Nr.: 182723	Ref.Nr.: 5131.71	Ref.Nr.: 503821	Ref.Nr.: 180906
<b>F8-5516</b>	<b>F8-5556</b>	<b>F8-5568</b>	<b>F8-6064</b>	<b>F8-6129</b>	<b>F8-6236</b>	<b>F8-6237</b>
Ref.Nr.: 503824	Ref.Nr.: 1843.95	Ref.Nr.: 184425	Ref.Nr.: 5033.26	Ref.Nr.: 509466	Ref.Nr.: 1809.21	Ref.Nr.: 1809.22
<b>F8-6272</b>	<b>F8-6296</b>	<b>F8-6497</b>	<b>F8-6500</b>	<b>F8-6505</b>	<b>F8-7083</b>	<b>F8-7084</b>
Ref.Nr.: 9556384280	Ref.Nr.: 503824	Ref.Nr.: 1844.75	Ref.Nr.: 1844.36	Ref.Nr.: 1844.51	Ref.Nr.: 0515.K6	Ref.Nr.: 0515.H6

Article Description



Article Nr.

Fitting Position



<b>306 Convertible (7D, N3, N5)</b>			<b>03/1994 → 04/2002</b>		
Bellow, steering	1.6, 1.8, 1.8 16V, 2.0, 2.0 16V	with clamps;	<b>LM-10004S</b>		d1=10; d2=40; L [mm]=175
Bellow, steering	1.6	TU5JP; with clamps;	<b>LM-10039S</b>		d1=40; d2=40; L [mm]=115
Bellow, steering	1.6, 1.8 16V, 2.0 16V	with clamps;	<b>LM-10039S</b>		d1=40; d2=40; L [mm]=115
Bellow, steering	1.8	XU7JP; Orga.→06657; with clamps;	<b>LM-10039S</b>		d1=40; d2=40; L [mm]=115
Bellow, steering	1.8	XU7JP; with clamps;	<b>LM-10039S</b>		d1=40; d2=40; L [mm]=115
Bellow, steering	2.0	XU10J2; Orga.→06657; with clamps;	<b>LM-10039S</b>		d1=40; d2=40; L [mm]=115
Bellow, steering	2.0	XU10J2; with clamps;	<b>LM-10039S</b>		d1=40; d2=40; L [mm]=115
Bellow, steering	1.6, 1.8, 1.8 16V, 2.0, 2.0 16V	with clamps	<b>LM-10054S</b>		d1=11; d2=39; L [mm]=66
<b>306 Hatchback (7A, 7C, N3, N5)</b>			<b>04/1993 → 05/2001</b>		
Dust Cover Kit, shock absorber	1.1, 1.4, 1.6, 1.8, 1.8 16V, 1.8 D, 1.9 D, 1.9 DT, 2.0 16V, 2.0 HDI 90, 2.0 S16, 2.0 XSi		<b>AK-735010</b>		
Alternator Freewheel Clutch	2.0 HDI 90		<b>F5-1020</b>		
Alternator Freewheel Clutch	2.0 HDI 90		<b>F5-1046</b>		
Anti-Friction Bearing	1.1, 1.4, 1.6, 1.8, 1.8 16V, 1.8 D, 1.9 D, 1.9 DT, 2.0 16V, 2.0 HDI 90, 2.0 S16, 2.0 XSi		<b>F8-3012</b>		H=20; d=66; D=100
Stabiliser Mounting	1.1, 1.4, 1.6, 1.8, 1.8 16V, 1.8 D, 1.9 D, 1.9 DT, 2.0 16V, 2.0 HDI 90, 2.0 S16, 2.0 XSi		<b>F8-5062</b>		d=17
Stabiliser Mounting	1.1, 1.4, 1.6, 1.8, 1.8 16V, 1.8 D, 1.9 D, 1.9 DT, 2.0 16V, 2.0 HDI 90, 2.0 S16, 2.0 XSi		<b>F8-5077</b>		d=18
Stabiliser Mounting	1.1, 1.4, 1.6, 1.8, 1.8 16V, 1.8 D, 1.9 D, 1.9 DT, 2.0 16V, 2.0 HDI 90, 2.0 S16, 2.0 XSi		<b>F8-5213</b>		D=21; d=21
Stabiliser Mounting	1.9 D, 2.0 S16		<b>F8-5213</b>		d=21
Control Arm-/Trailing Arm Bush	1.1, 1.4, 1.6, 1.8, 1.8 16V, 1.8 D, 1.9 D, 1.9 DT, 2.0 16V, 2.0 HDI 90, 2.0 S16, 2.0 XSi		<b>F8-5248</b>		
Mounting, axle beam	1.1, 1.4, 1.6, 1.8, 1.8 16V, 1.8 D, 1.9 D, 1.9 DT, 2.0 16V, 2.0 HDI 90, 2.0 S16, 2.0 XSi		<b>F8-5351</b>		
Mounting, axle beam	1.1, 1.4, 1.6, 1.8, 1.8 16V, 1.8 D, 1.9 D, 1.9 DT, 2.0 16V, 2.0 HDI 90, 2.0 S16, 2.0 XSi		<b>F8-5352</b>		
Control Arm-/Trailing Arm Bush	1.1, 1.4, 1.6, 1.8, 1.8 16V, 1.8 D, 1.9 D, 1.9 DT, 2.0 16V, 2.0 HDI 90, 2.0 S16, 2.0 XSi		<b>F8-5355</b>		
Bellow, driveshaft	1.1, 1.4	Transmission Type: MA	<b>F8-5356</b>		D1=72; D219; L=172
Bellow, driveshaft	1.6	Transmission Type: MAR	<b>F8-5356</b>		D1=72; D219; L=172
Bellow, driveshaft	1.8, 1.8 16V	Transmission Type: BE3	<b>F8-5356</b>		D1=72; D219; L=172
Bellow, driveshaft	1.9 D		<b>F8-5356</b>		D1=72; D219; L=172
Engine Mounting	1.6	03/1994 →	<b>F8-5357</b>		
Engine Mounting	1.8	01/1994 →;	<b>F8-5357</b>		
Engine Mounting	1.8 D, 1.9 D	ch.→O06884	<b>F8-5357</b>		
Engine Mounting	1.9 D	Orga.→06884	<b>F8-5357</b>		

<b>AK-735010</b>	<b>F5-1020</b>	<b>F5-1046</b>	<b>F8-3012</b>	<b>F8-5062</b>	<b>F8-5077</b>	<b>F8-5213</b>
Ref.Nr.:	Ref.Nr.: 31771-68D01	Ref.Nr.: 30667687	Ref.Nr.: 503527	Ref.Nr.: 5094.63	Ref.Nr.: 9615871880	Ref.Nr.: 5094.65
<b>F8-5248</b>	<b>F8-5351</b>	<b>F8-5352</b>	<b>F8-5355</b>	<b>F8-5356</b>	<b>F8-5357</b>	<b>LM-10004S</b>
Ref.Nr.: 3523.59	Ref.Nr.: 513170	Ref.Nr.: 513169	Ref.Nr.: 3520.H5S1	Ref.Nr.: 328769	Ref.Nr.: 1844.47	Ref.Nr.: 7910030073
<b>LM-10039S</b>	<b>LM-10054S</b>					
Ref.Nr.: 4066.22	Ref.Nr.: 4066.16					

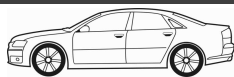
**Article Description****Article Nr.****Fitting Position**

<b>306 Hatchback (7A, 7C, N3, N5)</b>			<b>04/1993 → 05/2001</b>	
Engine Mounting	1.9 D, 1.9 DT		<b>F8-5357</b>	
Engine Mounting	2.0 S16, 2.0 XSi		<b>F8-5357</b>	
Engine Mounting	1.6		<b>F8-5358</b>	
Engine Mounting	1.8		<b>F8-5358</b>	
Engine Mounting	1.8		<b>F8-5359</b>	
Engine Mounting	1.8 16V		<b>F8-5359</b>	
Engine Mounting	1.8 D	Orga.06885→	<b>F8-5359</b>	
Engine Mounting	1.9 D	Orga.08240→	<b>F8-5359</b>	
Engine Mounting	1.9 DT, 2.0 16V, 2.0 S16	05/1997 →	<b>F8-5359</b>	
Engine Mounting	2.0 HDI 90		<b>F8-5359</b>	
Mounting, axle beam	1.1, 1.4, 1.6, 1.8, 1.8 16V, 1.8 D, 1.9 D, 1.9 DT, 2.0 16V, 2.0 HDI 90, 2.0 S16, 2.0 XSi		<b>F8-5363</b>	
Top Strut Mounting	1.1, 1.4, 1.6, 1.8, 1.8 16V, 1.8 D, 1.9 D, 1.9 DT, 2.0 16V, 2.0 HDI 90, 2.0 S16, 2.0 XSi		<b>F8-5364</b>	
Engine Mounting	1.1, 1.4, 1.6		<b>F8-5375</b>	H=34; d=12; D=30
Top Strut Mounting	1.1, 1.4, 1.6, 1.8, 1.8 16V, 1.8 D, 1.9 D, 1.9 DT, 2.0 16V, 2.0 HDI 90, 2.0 S16, 2.0 XSi		<b>F8-5516</b>	
Top Strut Mounting	1.1, 1.4, 1.6, 1.8, 1.9 D, 1.9 DT, 2.0 S16, 2.0 XSi		<b>F8-5517</b>	
Engine Mounting	1.8		<b>F8-5556</b>	
Engine Mounting	1.1, 1.8, 1.8 D, 1.9 DT, 2.0 16V, 2.0 HDI 90, 2.0 XSi		<b>F8-5568</b>	
Engine Mounting	1.4	TU3MC	<b>F8-5568</b>	
Engine Mounting	1.6, 1.8 16V, 2.0 S16		<b>F8-5568</b>	
Engine Mounting	2.0 S16	05/1997 →	<b>F8-5568</b>	
Belt Pulley, crankshaft	1.9 D	Orga.09520→	<b>F8-5636</b>	d=30
Belt Pulley, crankshaft	2.0 HDI 90		<b>F8-5636</b>	d=30
Belt Pulley, crankshaft	1.8 D, 1.9 D, 1.9 DT	Number of Ribs: 6	<b>F8-5643</b>	Belt Pulley Ø [mm]=156; W=44
Belt Pulley, crankshaft	1.9 D	ch.→O09519;	<b>F8-5659</b>	
Rubber Buffer, suspension	1.1, 1.4, 1.6, 1.8, 1.8 16V, 1.8 D, 1.9 D, 1.9 DT, 2.0 16V, 2.0 HDI 90, 2.0 S16, 2.0 XSi		<b>F8-6064</b>	L=79
Stabiliser Mounting	1.9 D, 2.0 HDI 90		<b>F8-6128</b>	d=22
Stabiliser Mounting	1.1, 1.4, 1.6, 1.8, 1.8 16V, 1.8 D, 1.9 D, 1.9 DT, 2.0 16V, 2.0 HDI 90, 2.0 S16, 2.0 XSi		<b>F8-6129</b>	d=19
Engine Mounting	1.8, 1.8 16V, 1.8 D, 1.9 D, 1.9 DT, 2.0 16V, 2.0 HDI 90, 2.0 S16, 2.0 XSi		<b>F8-6236</b>	H1=53; H2=40; d=10; D=70
Engine Mounting	1.8, 1.8 16V, 1.8 D, 1.9 D, 1.9 DT, 2.0 16V, 2.0 HDI 90, 2.0 S16, 2.0 XSi		<b>F8-6237</b>	
Repair Kit, wheel suspension	1.1, 1.4, 1.6, 1.8, 1.8 16V, 1.8 D, 1.9 D, 1.9 DT, 2.0 16V, 2.0 HDI 90, 2.0 S16, 2.0 XSi		<b>F8-6272</b>	

<b>F8-5357</b>	<b>F8-5358</b>	<b>F8-5359</b>	<b>F8-5363</b>	<b>F8-5364</b>	<b>F8-5375</b>	<b>F8-5516</b>
Ref.Nr.: 1844.47	Ref.Nr.: 184373	Ref.Nr.: 182723	Ref.Nr.: 5131.71	Ref.Nr.: 503821	Ref.Nr.: 180906	Ref.Nr.: 503824
<b>F8-5517</b>	<b>F8-5556</b>	<b>F8-5568</b>	<b>F8-5636</b>	<b>F8-5643</b>	<b>F8-5659</b>	<b>F8-6064</b>
Ref.Nr.: 5038.23	Ref.Nr.: 1843.95	Ref.Nr.: 184425	Ref.Nr.: 0515P2	Ref.Nr.: 96089 38980	Ref.Nr.: 0515Q6	Ref.Nr.: 5033.26
<b>F8-6128</b>	<b>F8-6129</b>	<b>F8-6236</b>	<b>F8-6237</b>	<b>F8-6272</b>	<b>F8-6296</b>	
Ref.Nr.: 5094.77	Ref.Nr.: 509466	Ref.Nr.: 1809.21	Ref.Nr.: 1809.22	Ref.Nr.: 9556384280	Ref.Nr.: 503824	

Article Description

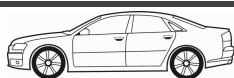

Article Nr.

Fitting Position



306 Hatchback (7A, 7C, N3, N5)			04/1993 → 05/2001	
Top Strut Mounting	1.1, 1.4, 1.6, 1.8, 1.8 16V, 1.8 D, 1.9 D, 1.9 DT, 2.0 16V, 2.0 HDI 90, 2.0 S16, 2.0 XSi		F8-6296	
Top Strut Mounting	1.1, 1.4, 1.6, 1.8, 1.8 16V, 1.8 D, 1.9 D, 1.9 DT, 2.0 16V, 2.0 HDI 90, 2.0 S16, 2.0 XSi		F8-6297	
Engine Mounting	1.1		F8-6487	
Engine Mounting	1.4	TU3JP, TU3MC	F8-6487	
Engine Mounting	1.6	01/1997 →;	F8-6497	
Engine Mounting	1.6		F8-6497	
Engine Mounting	1.8	XU7JP;	F8-6500	
Engine Mounting	1.8 16V, 2.0 S16		F8-6500	
Engine Mounting	1.8 D, 1.9 D, 2.0 16V, 2.0 HDI 90, 2.0 S16		F8-6500	
Engine Mounting	1.9 DT	XUD9TE	F8-6500	
Engine Mounting	2.0 XSi	XU10J2	F8-6500	
Mounting, automatic transmission	1.1, 1.6		F8-6505	
Mounting, automatic transmission	1.4	TU3JP, TU3M, TU3MC	F8-6505	
Belt Pulley, crankshaft	1.8 16V, 2.0 16V, 2.0 S16	Number of Ribs: 6	F8-7083	Belt Pulley Ø [mm]=127; Mounting points diam.[mm]=30; W=38
Belt Pulley, crankshaft	1.8, 2.0 XSi	06/1993 →; Number of Ribs: 6	F8-7084	Belt Pulley Ø [mm]=127; Mounting points diam.[mm]=30; W=45
Stabiliser Mounting	1.9 DT		F8-7943	
Repair Kit, wheel suspension	1.1, 1.4, 1.6, 1.8, 1.8 16V, 1.8 D, 1.9 D, 1.9 DT, 2.0 16V, 2.0 HDI 90, 2.0 S16, 2.0 XSi		G8-272	
Bellow, steering	1.1, 1.4, 1.6, 1.8, 1.8 16V, 1.8 D, 1.9 D, 1.9 DT, 2.0 16V, 2.0 HDI 90, 2.0 S16, 2.0 XSi	; Orga.→06656; with clamps;	LM-10004S	d1=10; d2=40; L [mm]=175
Bellow, steering	1.1, 1.4, 1.6, 1.8, 1.8 16V, 1.8 D, 1.9 D, 1.9 DT, 2.0 16V, 2.0 HDI 90, 2.0 S16, 2.0 XSi	; with clamps;	LM-10004S	d1=10; d2=40; L [mm]=175
Bellow, steering	1.1	TU1M; Orga.→06657; with clamps;	LM-10039S	d1=40; d2=40; L [mm]=115
Bellow, steering	1.1	TU1M; with clamps;	LM-10039S	d1=40; d2=40; L [mm]=115
Bellow, steering	1.4	TU3JP; Orga.→06657; with clamps;	LM-10039S	d1=40; d2=40; L [mm]=115
Bellow, steering	1.4	TU3JP; with clamps;	LM-10039S	d1=40; d2=40; L [mm]=115
Bellow, steering	1.4	TU3M; Orga.→06657; with clamps;	LM-10039S	d1=40; d2=40; L [mm]=115
Bellow, steering	1.4	TU3M; with clamps;	LM-10039S	d1=40; d2=40; L [mm]=115
Bellow, steering	1.4	TU3MC; Orga.→06657; with clamps;	LM-10039S	d1=40; d2=40; L [mm]=115

<b>F8-6296</b>	<b>F8-6297</b>	<b>F8-6487</b>	<b>F8-6497</b>	<b>F8-6500</b>	<b>F8-6505</b>	<b>F8-7083</b>
Ref.Nr.: 503824	Ref.Nr.: 503527	Ref.Nr.: 184472	Ref.Nr.: 1844.75	Ref.Nr.: 1844.36	Ref.Nr.: 1844.51	Ref.Nr.: 0515.K6
<b>F8-7084</b>	<b>F8-7943</b>	<b>G8-272</b>	<b>LM-10004S</b>	<b>LM-10039S</b>		
Ref.Nr.: 0515.H6	Ref.Nr.: 509479	Ref.Nr.: 5132.49	Ref.Nr.: 7910030073	Ref.Nr.: 4066.22		

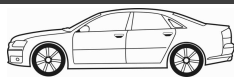

**Article Description****Article Nr.****Fitting Position**

<b>306 Hatchback (7A, 7C, N3, N5)</b>			<b>04/1993 → 05/2001</b>		
Bellow, steering	1.4	TU3MC; with clamps;	<b>LM-10039S</b>		d1=40; d2=40; L [mm]=115
Bellow, steering	1.6, 1.8 16V, 1.8 D, 1.9 D, 2.0 16V, 2.0 HDi 90, 2.0 S16	with clamps;	<b>LM-10039S</b>		d1=40; d2=40; L [mm]=115
Bellow, steering	1.6, 1.8 D, 1.9 D, 2.0 S16	Orga.→06657; with clamps;	<b>LM-10039S</b>		d1=40; d2=40; L [mm]=115
Bellow, steering	1.8	XU7JP; Orga.→06657; with clamps;	<b>LM-10039S</b>		d1=40; d2=40; L [mm]=115
Bellow, steering	1.8	XU7JP; with clamps;	<b>LM-10039S</b>		d1=40; d2=40; L [mm]=115
Bellow, steering	1.9 DT	XUD9TE; Orga.→06657; with clamps;	<b>LM-10039S</b>		d1=40; d2=40; L [mm]=115
Bellow, steering	1.9 DT	XUD9TE; with clamps;	<b>LM-10039S</b>		d1=40; d2=40; L [mm]=115
Bellow, steering	2.0 XSi	XU10J2; Orga.→06657; with clamps;	<b>LM-10039S</b>		d1=40; d2=40; L [mm]=115
Bellow, steering	2.0 XSi	XU10J2; with clamps;	<b>LM-10039S</b>		d1=40; d2=40; L [mm]=115
Bellow, steering	1.1, 1.4, 1.6, 1.8, 1.8 16V, 1.8 D, 1.9 D, 1.9 DT, 2.0 16V, 2.0 HDi 90, 2.0 S16, 2.0 XSi	with clamps	<b>LM-10054S</b>		d1=11; d2=39; L [mm]=66
<b>306 Van (N, 7)</b>			<b>02/1994 → 04/1999</b>		
Repair Kit, wheel suspension	1.9 D, 1.9 STD		<b>F8-6272</b>		
Repair Kit, wheel suspension	1.9 D, 1.9 STD		<b>G8-272</b>		
<b>307 (3A/C)</b>			<b>08/2000 →</b>		
Dust Cover Kit, shock absorber	1.4, 1.4 16V, 1.4 HDi, 1.6 16V, 1.6 HDi 110, 2.0 16V, 2.0 HDi 110, 2.0 HDi 135, 2.0 HDi 90		<b>AK-735068</b>		
Alternator Freewheel Clutch	2.0 HDi 90		<b>F5-1020</b>		
Alternator Freewheel Clutch	1.6 HDi, 1.6 HDi 110, 2.0 HDi 110, 2.0 HDi 135, 2.0 HDi 90		<b>F5-1046</b>		
Alternator Freewheel Clutch	1.4 HDi, 1.6 HDi, 1.6 HDi 110, 2.0 HDi 110, 2.0 HDi 135, 2.0 HDi 90		<b>F5-1048</b>		
Anti-Friction Bearing	1.4, 1.4 16V, 1.4 HDi, 1.6 16V, 1.6 BioFlex, 1.6 HDi, 1.6 HDi 110, 2.0 16V, 2.0 HDi 110, 2.0 HDi 135, 2.0 HDi 90		<b>F8-3012</b>		H=20; d=66; D=100
Engine Mounting	2.0 HDi 110, 2.0 HDi 135		<b>F8-5568</b>		
Belt Pulley, crankshaft	2.0 HDi 110, 2.0 HDi 90		<b>F8-5636</b>		d=30
Belt Pulley, crankshaft	2.0 HDi 110	ch.O09218→;	<b>F8-5660</b>		
Belt Pulley, crankshaft	2.0 HDi 90	ch.O09217→	<b>F8-5660</b>		
Top Strut Mounting	1.4, 1.4 16V, 1.4 HDi, 1.6 16V, 1.6 BioFlex, 1.6 HDi, 1.6 HDi 110, 2.0 16V, 2.0 HDi 110, 2.0 HDi 135, 2.0 HDi 90		<b>F8-6058</b>		
Control Arm-/Trailing Arm Bush	1.4 HDi	DV4TD	<b>F8-6134</b>		L=56.2; D=55.5
Control Arm-/Trailing Arm Bush	1.4, 1.4 16V, 1.6 16V, 1.6 HDi, 1.6 HDi 110, 2.0 16V, 2.0 HDi 110, 2.0 HDi 135, 2.0 HDi 90		<b>F8-6134</b>		L=56.2; D=55.5
Engine Mounting	1.4 HDi, 2.0 16V, 2.0 HDi 110, 2.0 HDi 90		<b>F8-6236</b>		H1=53; H2=40; d=10; D=70

<b>AK-735068</b>	<b>F5-1020</b>	<b>F5-1046</b>	<b>F5-1048</b>	<b>F8-3012</b>	<b>F8-5568</b>	<b>F8-5636</b>
Ref.Nr.: 503370	Ref.Nr.: 31771-68D01	Ref.Nr.: 30667687	Ref.Nr.: 77363468	Ref.Nr.: 503527	Ref.Nr.: 184425	Ref.Nr.: 0515P2
<b>F8-5660</b>	<b>F8-6058</b>	<b>F8-6134</b>	<b>F8-6236</b>	<b>F8-6272</b>	<b>F8-6302</b>	<b>G8-272</b>
Ref.Nr.: 0515R9	Ref.Nr.: 5038.F7	Ref.Nr.: 3523.91	Ref.Nr.: 1809.21	Ref.Nr.: 9556384280	Ref.Nr.: 503885	Ref.Nr.: 5132.49
<b>LM-10039S</b>	<b>LM-10054S</b>					
Ref.Nr.: 4066.22	Ref.Nr.: 4066.16					

Article Description			Article Nr.	Fitting Position	
---------------------	--	--	-------------	------------------	--

307 (3A/C)			08/2000 →		
Top Strut Mounting	1.4, 1.4 16V, 1.4 HDi, 1.6 16V, 1.6 BioFlex, 1.6 HDi, 1.6 HDi 110, 2.0 16V, 2.0 HDi 110, 2.0 HDi 135, 2.0 HDi 90		<b>F8-6302</b>		
Top Strut Mounting	1.4, 1.4 16V, 1.4 HDi, 1.6 16V, 1.6 HDi, 1.6 HDi 110, 2.0 16V, 2.0 HDi 110, 2.0 HDi 135, 2.0 HDi 90		<b>F8-6354</b>		
Belt Pulley, crankshaft	1.4, 1.4 16V, 1.6 16V, 1.6 BioFlex	Number of Ribs: 5; Parameter: 6PK	<b>F8-6394</b>		H=25; d=44.05; Mounting points diam.[mm]=9; D=148; D1=142.9
Engine Mounting	2.0, 2.0 16V, 2.0 HDi 110, 2.0 HDi 135, 2.0 HDi 90		<b>F8-6500</b>		
Mounting, automatic transmission	1.4, 1.4 16V, 1.4 HDi, 1.6 16V, 1.6 HDi, 1.6 HDi 110, 2.0 16V, 2.0 HDi 135		<b>F8-6505</b>		
Spring Cap	1.4, 1.4 16V, 1.4 HDi, 1.6 16V, 1.6 BioFlex, 1.6 HDi, 1.6 HDi 110, 2.0 16V, 2.0 HDi 110, 2.0 HDi 135, 2.0 HDi 90		<b>F8-6562</b>		
Rubber Buffer, suspension	1.4, 1.4 16V, 1.4 HDi, 1.6 16V, 1.6 BioFlex, 1.6 HDi, 1.6 HDi 110, 2.0 16V, 2.0 HDi 110, 2.0 HDi 135, 2.0 HDi 90		<b>F8-6564</b>		
Mounting, axle beam	1.4, 1.4 16V, 1.4 HDi, 1.6 16V, 1.6 HDi, 1.6 HDi 110, 2.0 16V, 2.0 HDi 110, 2.0 HDi 135, 2.0 HDi 90	for OE: 5131A4	<b>F8-6591</b>		H=82; d=16.8; D=71.5
Stabiliser Mounting	1.4, 1.4 16V, 1.4 HDi, 1.6 16V, 1.6 BioFlex, 1.6 HDi, 1.6 HDi 110, 2.0 16V, 2.0 HDi 110, 2.0 HDi 135, 2.0 HDi 90	Stabi. Diam. [mm]= 21	<b>F8-6593</b>		d=21
Stabiliser Mounting	1.4, 1.4 16V, 1.4 HDi, 1.6 16V, 1.6 BioFlex, 1.6 HDi, 1.6 HDi 110, 2.0 16V, 2.0 HDi 110, 2.0 HDi 135, 2.0 HDi 90		<b>F8-6594</b>		d=22
Belt Pulley, crankshaft	1.6 HDi	Number of Ribs: 6	<b>F8-7082</b>		Belt Pulley Ø [mm]=152; Mounting points diam.[mm]=30; W=34
Belt Pulley, crankshaft	1.6 HDi 110	07/2004 →; Number of Ribs: 6	<b>F8-7082</b>		Belt Pulley Ø [mm]=152; Mounting points diam.[mm]=30; W=34
Rubber Buffer, suspension	1.4, 1.4 16V, 1.4 HDi, 1.6 BioFlex, 1.6 HDi, 1.6 HDi 110, 2.0 16V, 2.0 HDi 110, 2.0 HDi 135, 2.0 HDi 90		<b>F8-7585</b>		H=96
Rubber Buffer, suspension	1.6 16V	01/2005 →; Orga.→10661	<b>F8-7585</b>		H=96
Rubber Buffer, suspension	2.0 16V	Orga.→10661	<b>F8-7585</b>		H=96
Belt Pulley, crankshaft	1.4 16V, 1.6 16V	Alternator Charge Current [A]: 120; Number of Ribs: 5; Parameter: 6PK	<b>F8-7644</b>		D=152
Belt Pulley, crankshaft	2.0 HDi 135		<b>F8-7861</b>		
Engine Mounting	1.6 HDi, 1.6 HDi 110, 2.0 16V, 2.0 HDi 135, 2.0 HDi 90		<b>F8-8184</b>		
Control Arm-/Trailing Arm Bush	1.4, 1.4 16V, 1.4 HDi, 1.6 16V, 1.6 HDi, 1.6 HDi 110, 2.0 16V, 2.0 HDi 110, 2.0 HDi 135, 2.0 HDi 90		<b>G9-698</b>		H=50.5; d=14; D=55.5
Control Arm-/Trailing Arm Bush	1.4, 1.4 16V, 1.4 HDi, 1.6 16V, 1.6 HDi, 1.6 HDi 110, 2.0 16V, 2.0 HDi 110, 2.0 HDi 135, 2.0 HDi 90		<b>G9-699</b>		H=48.8; d=14; D=55.4
Bellow, steering	1.4, 1.4 16V, 1.4 HDi, 1.6 16V, 1.6 BioFlex, 1.6 HDi, 1.6 HDi 110, 2.0 16V, 2.0 HDi 110, 2.0 HDi 135, 2.0 HDi 90	; ; with clamps;	<b>LM-10040S</b>		d1=17; d2=60; L [mm]=183

<b>F8-6302</b>	<b>F8-6354</b>	<b>F8-6394</b>	<b>F8-6500</b>	<b>F8-6505</b>	<b>F8-6562</b>	<b>F8-6564</b>
Ref.Nr.: 503885	Ref.Nr.: 514232	Ref.Nr.: 0515.R8	Ref.Nr.: 1844.36	Ref.Nr.: 1844.51	Ref.Nr.: 5033.75	Ref.Nr.: 503371
<b>F8-6591</b>	<b>F8-6593</b>	<b>F8-6594</b>	<b>F8-7082</b>	<b>F8-7585</b>	<b>F8-7644</b>	<b>F8-7861</b>
Ref.Nr.: 5131.A4	Ref.Nr.: 5094.87	Ref.Nr.: 509488	Ref.Nr.: 0515.R0	Ref.Nr.: 5033.70	Ref.Nr.: 0515.R4	Ref.Nr.: 0515 Q8
<b>F8-8184</b>	<b>G9-698</b>	<b>G9-699</b>	<b>LM-10040S</b>			
Ref.Nr.: 1806.33	Ref.Nr.: 352376	Ref.Nr.: 96286665	Ref.Nr.: 4066.82			

**Article Description****Article Nr.****Fitting Position**

<b>307 Estate (3E)</b>		<b>03/2002 → 09/2003</b>	
Dust Cover Kit, shock absorber	1.4 16V, 1.4 HDi, 1.6 16V, 1.6 HDi 110, 2.0, 2.0 16V, 2.0 HDi 135, 2.0 HDi 90		<b>AK-735068</b>
Alternator Freewheel Clutch	2.0 HDi 110, 2.0 HDi 90		<b>F5-1020</b>
Alternator Freewheel Clutch	1.6 HDi, 1.6 HDi 110, 2.0 HDi 110, 2.0 HDi 135, 2.0 HDi 90		<b>F5-1046</b>
Alternator Freewheel Clutch	1.4 HDi, 1.6 HDi, 1.6 HDi 110, 2.0 HDi 110, 2.0 HDi 135, 2.0 HDi 90		<b>F5-1048</b>
Anti-Friction Bearing	All Models		<b>F8-3012</b>
Belt Pulley, crankshaft	2.0 HDi 110	for vehicles with diesel soot filter	<b>F8-5636</b> d=30
Belt Pulley, crankshaft	2.0 HDi 90	Orga.→09216	<b>F8-5636</b> d=30
Belt Pulley, crankshaft	2.0 HDi 110, 2.0 HDi 90	Orga.09217→	<b>F8-5660</b>
Top Strut Mounting	All Models		<b>F8-6058</b>
Control Arm-/Trailing Arm Bush	All Models		<b>F8-6134</b> L=56.2; D=55.5
Engine Mounting	1.4 HDi, 2.0, 2.0 HDi 110, 2.0 HDi 90		<b>F8-6236</b>
Top Strut Mounting	All Models		<b>F8-6302</b>
Top Strut Mounting	1.4 16V, 1.4 HDi, 1.6 16V, 1.6 HDi 110, 2.0, 2.0 16V, 2.0 HDi 135, 2.0 HDi 90		<b>F8-6354</b>
Belt Pulley, crankshaft	1.4, 1.4 16V, 1.6 16V, 1.6 BioFlex	Number of Ribs: 5; Parameter: 6PK	<b>F8-6394</b> H=25; d=44.05; Mounting points diam.[mm]=9; D=148; D1=142.9
Engine Mounting	2.0, 2.0 16V, 2.0 HDi 110, 2.0 HDi 135, 2.0 HDi 90		<b>F8-6500</b>
Mounting, automatic transmission	1.4, 1.4 16V, 1.4 HDi, 1.6 16V, 1.6 HDi, 1.6 HDi 110, 2.0, 2.0 16V, 2.0 HDi 135		<b>F8-6505</b>
Spring Cap	All Models		<b>F8-6562</b>
Rubber Buffer, suspension	All Models		<b>F8-6564</b>
Mounting, axle beam	1.4 16V, 1.4 HDi, 1.6 16V, 1.6 BioFlex, 1.6 HDi, 1.6 HDi 110, 2.0, 2.0 16V, 2.0 HDi 110, 2.0 HDi 135, 2.0 HDi 90	for OE: 5131A4	<b>F8-6591</b> H=82; d=16.8; D=71.5
Mounting, axle beam	1.4 16V, 1.4 HDi, 1.6 16V, 1.6 HDi 110, 2.0, 2.0 HDi 110, 2.0 HDi 135, 2.0 HDi 90	01/2005 →; for OE: 5131A5	<b>F8-6592</b>
Mounting, axle beam	2.0 16V	for OE: 5131A5	<b>F8-6592</b>
Stabiliser Mounting	All Models	Stabi. Diam. [mm]= 21	<b>F8-6593</b> d=21
Stabiliser Mounting	All Models		<b>F8-6594</b> d=22
Belt Pulley, crankshaft	1.6 HDi	06/2005 →; Number of Ribs: 6	<b>F8-7082</b> Belt Pulley Ø [mm]=152; Mounting points diam.[mm]=30; W=34
Belt Pulley, crankshaft	1.6 HDi 110	07/2004 →; Number of Ribs: 6	<b>F8-7082</b> Belt Pulley Ø [mm]=152; Mounting points diam.[mm]=30; W=34
Rubber Buffer, suspension	1.4, 1.4 16V, 1.4 HDi, 1.6 BioFlex, 1.6 HDi, 1.6 HDi 110, 2.0, 2.0 16V, 2.0 HDi 110, 2.0 HDi 135, 2.0 HDi 90		<b>F8-7585</b> H=96

<b>AK-735068</b>	<b>F5-1020</b>	<b>F5-1046</b>	<b>F5-1048</b>	<b>F8-3012</b>	<b>F8-5636</b>	<b>F8-5660</b>
Ref.Nr.: 503370	Ref.Nr.: 31771-68D01	Ref.Nr.: 30667687	Ref.Nr.: 77363468	Ref.Nr.: 503527	Ref.Nr.: 0515P2	Ref.Nr.: 0515R9
<b>F8-6058</b>	<b>F8-6134</b>	<b>F8-6236</b>	<b>F8-6302</b>	<b>F8-6354</b>	<b>F8-6394</b>	<b>F8-6500</b>
Ref.Nr.: 5038.F7	Ref.Nr.: 3523.91	Ref.Nr.: 1809.21	Ref.Nr.: 503885	Ref.Nr.: 514232	Ref.Nr.: 0515.R8	Ref.Nr.: 1844.36
<b>F8-6505</b>	<b>F8-6562</b>	<b>F8-6564</b>	<b>F8-6591</b>	<b>F8-6592</b>	<b>F8-6593</b>	<b>F8-6594</b>
Ref.Nr.: 1844.51	Ref.Nr.: 5033.75	Ref.Nr.: 503371	Ref.Nr.: 5131.A4	Ref.Nr.: 5131.A5	Ref.Nr.: 5094.87	Ref.Nr.: 509488

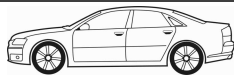
**Article Description**

**Article Nr.**
**Fitting Position**

<b>307 Estate (3E)</b>			<b>03/2002 → 09/2003</b>		
Rubber Buffer, suspension	1.6 16V	01/2005 →; Orga.→10661	<b>F8-7585</b>		H=96
Rubber Buffer, suspension	2.0 16V	Orga.→10661	<b>F8-7585</b>		H=96
Belt Pulley, crankshaft	1.4 16V, 1.6 16V	Alternator Charge Current [A]: 120; Number of Ribs: 5; Parameter: 6PK	<b>F8-7644</b>		D=152
Belt Pulley, crankshaft	2.0 HDi 135		<b>F8-7861</b>		
Engine Mounting	1.6 HDi, 1.6 HDi 110, 2.0, 2.0 16V, 2.0 HDi 135		<b>F8-8184</b>		
Control Arm-/Trailing Arm Bush	1.4 16V, 1.4 HDi, 1.6 16V, 1.6 HDi, 1.6 HDi 110, 2.0, 2.0 16V, 2.0 HDi 110, 2.0 HDi 135, 2.0 HDi 90		<b>G9-698</b>		H=50.5; d=14; D=55.5
Control Arm-/Trailing Arm Bush	1.4 16V, 1.4 HDi, 1.6 16V, 1.6 HDi, 1.6 HDi 110, 2.0, 2.0 16V, 2.0 HDi 110, 2.0 HDi 135, 2.0 HDi 90		<b>G9-699</b>		H=48.8; d=14; D=55.4
Bellow, steering	All Models	; with clamps;	<b>LM-10040S</b>		d1=17; d2=60; L [mm]=183
<b>307 CC (3B)</b>			<b>10/2003 →</b>		
Dust Cover Kit, shock absorber	All Models		<b>AK-735068</b>		
Alternator Freewheel Clutch	2.0 HDi 135		<b>F5-1046</b>		
Alternator Freewheel Clutch	2.0 HDi 135		<b>F5-1048</b>		
Anti-Friction Bearing	All Models		<b>F8-3012</b>		H=20; d=66; D=100
Top Strut Mounting	All Models		<b>F8-6058</b>		
Control Arm-/Trailing Arm Bush	All Models		<b>F8-6134</b>		L=56.2; D=55.5
Engine Mounting	2.0 16V		<b>F8-6236</b>		H1=53; H2=40; d=10; D=70
Top Strut Mounting	All Models		<b>F8-6302</b>		
Top Strut Mounting	All Models		<b>F8-6354</b>		
Belt Pulley, crankshaft	1.6 16V	Number of Ribs: 5; Parameter: 6PK	<b>F8-6394</b>		H=25; d=44.05; Mounting points diam.[mm]=9; D=148; D1=142.9
Engine Mounting	2.0 16V, 2.0 HDi 135		<b>F8-6500</b>		
Mounting, automatic transmission	1.6 16V, 2.0 16V, 2.0 HDi 135		<b>F8-6505</b>		
Spring Cap	All Models		<b>F8-6562</b>		
Mounting, axle beam	All Models	for OE: 5131A4	<b>F8-6591</b>		H=82; d=16.8; D=71.5
Mounting, axle beam	1.6 16V, 2.0 16V, 2.0 HDi 135	for OE: 5131A5	<b>F8-6592</b>		
Mounting, axle beam	2.0 16V	01/2005 →; for OE: 5131A5	<b>F8-6592</b>		
Stabiliser Mounting	All Models	Stabi. Diam. [mm]= 21	<b>F8-6593</b>		d=21
Stabiliser Mounting	All Models		<b>F8-6594</b>		d=22
Rubber Buffer, suspension	1.6 16V, 2.0 16V	Orga.→10661	<b>F8-7585</b>		H=96
Rubber Buffer, suspension	2.0 16V, 2.0 HDi 135		<b>F8-7585</b>		H=96
Belt Pulley, crankshaft	1.6 16V	Alternator Charge Current [A]: 120; Number of Ribs: 5; Parameter: 6PK	<b>F8-7644</b>		D=152
Engine Mounting	2.0 16V, 2.0 HDi 135		<b>F8-8184</b>		

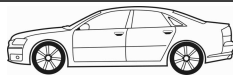
<b>AK-735068</b>	<b>F5-1046</b>	<b>F5-1048</b>	<b>F8-3012</b>	<b>F8-6058</b>	<b>F8-6134</b>	<b>F8-6236</b>
Ref.Nr.: 503370	Ref.Nr.: 30667687	Ref.Nr.: 77363468	Ref.Nr.: 503527	Ref.Nr.: 5038.F7	Ref.Nr.: 3523.91	Ref.Nr.: 1809.21
<b>F8-6302</b>	<b>F8-6354</b>	<b>F8-6394</b>	<b>F8-6500</b>	<b>F8-6505</b>	<b>F8-6562</b>	<b>F8-6591</b>
Ref.Nr.: 503885	Ref.Nr.: 514232	Ref.Nr.: 0515.R8	Ref.Nr.: 1844.36	Ref.Nr.: 1844.51	Ref.Nr.: 5033.75	Ref.Nr.: 5131.A4
<b>F8-6592</b>	<b>F8-6593</b>	<b>F8-6594</b>	<b>F8-7585</b>	<b>F8-7644</b>	<b>F8-7861</b>	<b>F8-8184</b>
Ref.Nr.: 5131.A5	Ref.Nr.: 5094.87	Ref.Nr.: 509488	Ref.Nr.: 5033.70	Ref.Nr.: 0515.R4	Ref.Nr.: 0515 Q8	Ref.Nr.: 1806.33

**Article Description****Article Nr.****Fitting Position**

<b>307 CC (3B)</b>				<b>10/2003 →</b>	
Control Arm-/Trailing Arm Bush	2.0 16V		<b>G9-699</b>		H=48.8; d=14; D=55.4
Bellow, steering	All Models		<b>LM-10040S</b>		d1=17; d2=60; L [mm]=183
<b>307 SW (3H)</b>				<b>03/2002 → 09/2003</b>	
Dust Cover Kit, shock absorber	1.4 16V, 1.6 16V, 1.6 HDI 110, 2.0 16V, 2.0 HDI 110, 2.0 HDi 135, 2.0 HDI 90		<b>AK-735068</b>		
Alternator Freewheel Clutch	2.0 HDI 110, 2.0 HDI 90		<b>F5-1020</b>		
Alternator Freewheel Clutch	1.6 HDI 110, 1.6 HDI 90, 2.0 HDI 110, 2.0 HDi 135, 2.0 HDI 90		<b>F5-1046</b>		
Alternator Freewheel Clutch	1.6 HDI 110, 1.6 HDI 90, 2.0 HDI 110, 2.0 HDi 135, 2.0 HDI 90		<b>F5-1048</b>		
Anti-Friction Bearing	1.4, 1.4 16V, 1.6 16V, 1.6 BioFlex, 1.6 HDI 110, 1.6 HDI 90, 2.0 16V, 2.0 HDI 110, 2.0 HDi 135, 2.0 HDI 90		<b>F8-3012</b>		H=20; d=66; D=100
Belt Pulley, crankshaft	2.0 HDI 110	for vehicles with diesel soot filter	<b>F8-5636</b>		d=30
Belt Pulley, crankshaft	2.0 HDI 90	Orga.→09216	<b>F8-5636</b>		d=30
Belt Pulley, crankshaft	2.0 HDI 110	ch.O09218→;	<b>F8-5660</b>		
Belt Pulley, crankshaft	2.0 HDI 90	Orga.09217→	<b>F8-5660</b>		
Top Strut Mounting	1.4, 1.4 16V, 1.6 16V, 1.6 BioFlex, 1.6 HDI 110, 1.6 HDI 90, 2.0 16V, 2.0 HDI 110, 2.0 HDi 135, 2.0 HDI 90		<b>F8-6058</b>		
Control Arm-/Trailing Arm Bush	1.4 16V, 1.6 16V, 1.6 HDI 110, 1.6 HDI 90, 2.0 16V, 2.0 HDI 110, 2.0 HDi 135, 2.0 HDI 90		<b>F8-6134</b>		L=56.2; D=55.5
Engine Mounting	2.0 16V, 2.0 HDI 110, 2.0 HDI 90		<b>F8-6236</b>		H1=53; H2=40; d=10; D=70
Top Strut Mounting	1.4, 1.4 16V, 1.6 16V, 1.6 BioFlex, 1.6 HDI 110, 1.6 HDI 90, 2.0 16V, 2.0 HDI 110, 2.0 HDi 135, 2.0 HDI 90		<b>F8-6302</b>		
Top Strut Mounting	1.4 16V, 1.6 16V, 1.6 HDI 110, 2.0 16V, 2.0 HDI 110, 2.0 HDi 135, 2.0 HDI 90		<b>F8-6354</b>		
Belt Pulley, crankshaft	1.4 16V, 1.6 16V, 1.6 BioFlex	Number of Ribs: 5; Parameter: 6PK	<b>F8-6394</b>		H=25; d=44.05; Mounting points diam.[mm]=9; D=148; D1=142.9
Engine Mounting	2.0 16V, 2.0 HDI 110, 2.0 HDi 135, 2.0 HDI 90		<b>F8-6500</b>		
Mounting, automatic transmission	1.4 16V, 1.6 16V, 1.6 HDI 110, 1.6 HDI 90, 2.0 16V, 2.0 HDi 135		<b>F8-6505</b>		
Spring Cap	1.4, 1.4 16V, 1.6 16V, 1.6 BioFlex, 1.6 HDI 110, 1.6 HDI 90, 2.0 16V, 2.0 HDI 110, 2.0 HDi 135, 2.0 HDI 90		<b>F8-6562</b>		
Mounting, axle beam	1.4 16V, 1.6 16V, 1.6 HDI 110, 1.6 HDI 90, 2.0 16V, 2.0 HDI 110, 2.0 HDi 135, 2.0 HDI 90	for OE: 5131A4	<b>F8-6591</b>		H=82; d=16.8; D=71.5
Mounting, axle beam	1.4 16V, 1.6 16V, 1.6 HDI 110, 2.0 16V, 2.0 HDI 110, 2.0 HDi 135, 2.0 HDI 90	01/2005 →; for OE: 5131A5	<b>F8-6592</b>		
Mounting, axle beam	2.0 16V	for OE: 5131A5	<b>F8-6592</b>		
Stabiliser Mounting	1.4, 1.4 16V, 1.6 16V, 1.6 BioFlex, 1.6 HDI 110, 1.6 HDI 90, 2.0 16V, 2.0 HDI 110, 2.0 HDi 135, 2.0 HDI 90	Stabi. Diam. [mm]= 21	<b>F8-6593</b>		d=21
Stabiliser Mounting	1.4, 1.4 16V, 1.6 16V, 1.6 BioFlex, 1.6 HDI 110, 1.6 HDI 90, 2.0 16V, 2.0 HDI 110, 2.0 HDi 135, 2.0 HDI 90		<b>F8-6594</b>		d=22

<b>AK-735068</b>	<b>F5-1020</b>	<b>F5-1046</b>	<b>F5-1048</b>	<b>F8-3012</b>	<b>F8-5636</b>	<b>F8-5660</b>
Ref.Nr.: 503370	Ref.Nr.: 31771-68D01	Ref.Nr.: 30667687	Ref.Nr.: 77363468	Ref.Nr.: 503527	Ref.Nr.: 0515P2	Ref.Nr.: 0515R9
<b>F8-6058</b>	<b>F8-6134</b>	<b>F8-6236</b>	<b>F8-6302</b>	<b>F8-6354</b>	<b>F8-6394</b>	<b>F8-6500</b>
Ref.Nr.: 5038.F7	Ref.Nr.: 3523.91	Ref.Nr.: 1809.21	Ref.Nr.: 503885	Ref.Nr.: 514232	Ref.Nr.: 0515.R8	Ref.Nr.: 1844.36
<b>F8-6505</b>	<b>F8-6562</b>	<b>F8-6591</b>	<b>F8-6592</b>	<b>F8-6593</b>	<b>F8-6594</b>	<b>F8-7082</b>
Ref.Nr.: 1844.51	Ref.Nr.: 5033.75	Ref.Nr.: 5131.A4	Ref.Nr.: 5131.A5	Ref.Nr.: 5094.87	Ref.Nr.: 509488	Ref.Nr.: 0515.R0

Article Description

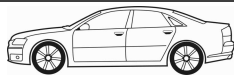

Article Nr.

Fitting Position



307 SW (3H)			03/2002 → 09/2003		
Belt Pulley, crankshaft	1.6 HDi 110	07/2004 →; Number of Ribs: 6	<b>F8-7082</b>		Belt Pulley Ø [mm]=152; Mounting points diam.[mm]=30; W=34
Belt Pulley, crankshaft	1.6 HDi 90	Number of Ribs: 6; Orga.→10555	<b>F8-7082</b>		Belt Pulley Ø [mm]=152; Mounting points diam.[mm]=30; W=34
Rubber Buffer, suspension	1.4, 1.4 16V, 1.6 BioFlex, 1.6 HDi 110, 1.6 HDi 90, 2.0 16V, 2.0 HDi 110, 2.0 HDi 135, 2.0 HDi 90		<b>F8-7585</b>		H=96
Rubber Buffer, suspension	1.6 16V	01/2005 →; Orga.→10661	<b>F8-7585</b>		H=96
Rubber Buffer, suspension	2.0 16V	Orga.→10661	<b>F8-7585</b>		H=96
Belt Pulley, crankshaft	1.4 16V	Alternator Charge Current [A]: 120; Number of Ribs: 5; Parameter: 6PK	<b>F8-7644</b>		D=152
Belt Pulley, crankshaft	2.0 HDi 135		<b>F8-7861</b>		
Engine Mounting	1.6 HDi 110, 2.0 16V, 2.0 HDi 135		<b>F8-8184</b>		
Control Arm-/Trailing Arm Bush	1.4 16V, 1.6 16V, 1.6 HDi 110, 2.0 16V, 2.0 HDi 110, 2.0 HDi 135, 2.0 HDi 90		<b>G9-698</b>		H=50.5; d=14; D=55.5
Control Arm-/Trailing Arm Bush	1.4 16V, 1.6 16V, 1.6 HDi 110, 2.0 16V, 2.0 HDi 110, 2.0 HDi 135, 2.0 HDi 90		<b>G9-699</b>		H=48.8; d=14; D=55.4
Bellow, steering	1.4, 1.4 16V, 1.6 16V, 1.6 BioFlex, 1.6 HDi 110, 1.6 HDi 90, 2.0 16V, 2.0 HDi 110, 2.0 HDi 135, 2.0 HDi 90	; with clamps;	<b>LM-10040S</b>		d1=17; d2=60; L [mm]=183
308 (4A, 4C)			09/2007 →		
Dust Cover Kit, shock absorber	1.4 16V, 1.6 16V, 1.6 HDi, 2.0 HDi		<b>AK-735068</b>		
Dust Cover Kit, shock absorber	1.4 16V, 1.6 16V, 1.6 GTi, 1.6 HDi, 2.0 HDi		<b>AK-735438</b>		
Alternator Freewheel Clutch	1.6 HDi, 2.0 HDi		<b>F5-1046</b>		
Alternator Freewheel Clutch	1.6 HDi, 2.0 HDi		<b>F5-1048</b>		
Alternator Freewheel Clutch	1.4 16V, 1.6 16V, 1.6 GTi		<b>F5-1113</b>		
Alternator Freewheel Clutch	1.4 16V, 1.6 16V, 1.6 GTi		<b>F5-1132</b>		
Anti-Friction Bearing	1.4 16V, 1.6, 1.6 16V, 1.6 BioFlex, 1.6 GTi, 1.6 HDi, 2.0 HDi		<b>F8-3012</b>		H=20; d=66; D=100
Control Arm-/Trailing Arm Bush	1.4 16V, 1.6 16V, 1.6 HDi, 2.0 HDi		<b>F8-6134</b>		L=56.2; D=55.5
Belt Pulley, crankshaft	1.6 BioFlex	Number of Ribs: 5; Parameter: 6PK	<b>F8-6394</b>		H=25; d=44.05; Mounting points diam.[mm]=9; D=148; D1=142.9
Engine Mounting	1.6 16V, 1.6 BioFlex		<b>F8-6500</b>		
Engine Mounting	1.6 HDi	Automated	<b>F8-6500</b>		
Engine Mounting	1.6 HDi	DV6TED4; Automated	<b>F8-6500</b>		
Mounting, automatic transmission	1.4 16V, 1.6 16V, 1.6 HDi		<b>F8-6505</b>		
Stabiliser Mounting	1.4 16V, 1.6, 1.6 16V, 1.6 BioFlex, 1.6 GTi, 1.6 HDi, 2.0 HDi	Stabi. Diam. [mm]= 21	<b>F8-6593</b>		d=21
Stabiliser Mounting	1.4 16V, 1.6 16V, 1.6 HDi, 2.0 HDi		<b>F8-6594</b>		d=22

<b>AK-735068</b>	<b>AK-735438</b>	<b>F5-1046</b>	<b>F5-1048</b>	<b>F5-1113</b>	<b>F5-1132</b>	<b>F8-3012</b>
Ref.Nr.: 503370	Ref.Nr.: 525442	Ref.Nr.: 30667687	Ref.Nr.: 77363468	Ref.Nr.: 12317576515	Ref.Nr.:	Ref.Nr.: 503527
<b>F8-6134</b>	<b>F8-6394</b>	<b>F8-6500</b>	<b>F8-6505</b>	<b>F8-6593</b>	<b>F8-6594</b>	<b>F8-7082</b>
Ref.Nr.: 3523.91	Ref.Nr.: 0515.R8	Ref.Nr.: 1844.36	Ref.Nr.: 1844.51	Ref.Nr.: 5094.87	Ref.Nr.: 509488	Ref.Nr.: 0515.R0
<b>F8-7169</b>	<b>F8-7585</b>	<b>F8-7644</b>	<b>F8-7861</b>	<b>F8-8184</b>	<b>G9-698</b>	<b>G9-699</b>
Ref.Nr.: 9658296580	Ref.Nr.: 5033.70	Ref.Nr.: 0515.R4	Ref.Nr.: 0515 Q8	Ref.Nr.: 1806.33	Ref.Nr.: 352376	Ref.Nr.: 96286665

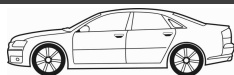
**Article Description****Article Nr.****Fitting Position**

<b>308 (4A, 4C)</b>			<b>09/2007 →</b>		
Top Strut Mounting	1.4 16V, 1.6 16V, 1.6 GTi, 1.6 HDi, 2.0 HDi	Aluminium;	<b>F8-7169</b>		H=52; d=10.2; D=62
Rubber Buffer, suspension	1.4 16V, 1.6, 1.6 16V, 1.6 BioFlex, 1.6 GTi, 1.6 HDi, 2.0 HDi		<b>F8-7585</b>		H=96
Bellow, steering	1.4 16V, 1.6 16V, 1.6 BioFlex, 1.6 GTi, 1.6 HDi, 2.0 HDi	; ; with clamps;	<b>LM-10040S</b>		d1=17; d2=60; L [mm]=183
<b>308 CC</b>			<b>04/2009 →</b>		
Dust Cover Kit, shock absorber	1.6 16V, 1.6 HDi, 2.0 HDi		<b>AK-735068</b>		
Dust Cover Kit, shock absorber	1.6 16V, 1.6 HDi, 2.0 HDi		<b>AK-735438</b>		
Alternator Freewheel Clutch	2.0 HDi		<b>F5-1046</b>		
Alternator Freewheel Clutch	2.0 HDi		<b>F5-1048</b>		
Alternator Freewheel Clutch	1.6 16V, 1.6 THP		<b>F5-1113</b>		
Alternator Freewheel Clutch	1.6 16V, 1.6 THP		<b>F5-1132</b>		
Anti-Friction Bearing	1.6 16V, 1.6 HDi, 1.6 THP, 2.0 HDi		<b>F8-3012</b>		H=20; d=66; D=100
Control Arm-/Trailing Arm Bush	1.6 16V, 1.6 HDi, 2.0 HDi		<b>F8-6134</b>		L=56.2; D=55.5
Engine Mounting	1.6 16V		<b>F8-6500</b>		
Stabiliser Mounting	1.6 16V, 1.6 HDi, 1.6 THP, 2.0 HDi	Stabi. Diam. [mm]= 21	<b>F8-6593</b>		d=21
Top Strut Mounting	1.6 16V, 1.6 HDi, 2.0 HDi	Aluminium;	<b>F8-7169</b>		H=52; d=10.2; D=62
Rubber Buffer, suspension	1.6 16V, 1.6 HDi, 1.6 THP, 2.0 HDi		<b>F8-7585</b>		H=96
Bellow, steering	1.6 16V, 1.6 HDi, 1.6 THP, 2.0 HDi	; ; with clamps;	<b>LM-10040S</b>		d1=17; d2=60; L [mm]=183
<b>308 SW</b>			<b>09/2007 →</b>		
Dust Cover Kit, shock absorber	1.4 16V, 1.6 16V, 1.6 Bioflex, 1.6 HDi, 2.0 Bioflex, 2.0 HDi		<b>AK-735068</b>		
Dust Cover Kit, shock absorber	1.4 16V, 1.6 16V, 1.6 Bioflex, 1.6 HDi, 2.0 Bioflex, 2.0 HDi		<b>AK-735438</b>		
Alternator Freewheel Clutch	1.6 HDi, 2.0 HDi		<b>F5-1046</b>		
Alternator Freewheel Clutch	1.6 HDi, 2.0 HDi		<b>F5-1048</b>		
Alternator Freewheel Clutch	1.4 16V, 1.6 16V		<b>F5-1113</b>		
Alternator Freewheel Clutch	1.4 16V, 1.6 16V		<b>F5-1132</b>		
Anti-Friction Bearing	All Models		<b>F8-3012</b>		H=20; d=66; D=100
Control Arm-/Trailing Arm Bush	1.4 16V, 1.6 16V, 1.6 HDi, 2.0 Bioflex, 2.0 HDi		<b>F8-6134</b>		L=56.2; D=55.5
Belt Pulley, crankshaft	1.6 Bioflex	Number of Ribs: 5; Parameter: 6PK	<b>F8-6394</b>		H=25; d=44.05; Mounting points diam.[mm]=9; D=148; D1=142.9
Engine Mounting	1.6 16V		<b>F8-6500</b>		
Engine Mounting	1.6 16V	EP6DT;	<b>F8-6500</b>		
Engine Mounting	1.6 HDi	Automated	<b>F8-6500</b>		
Engine Mounting	1.6 HDi	DV6ATED4; Automated	<b>F8-6500</b>		

<b>AK-735068</b>	<b>AK-735438</b>	<b>F5-1046</b>	<b>F5-1048</b>	<b>F5-1113</b>	<b>F5-1132</b>	<b>F8-3012</b>
Ref.Nr.: 503370	Ref.Nr.: 525442	Ref.Nr.: 30667687	Ref.Nr.: 77363468	Ref.Nr.: 12317576515	Ref.Nr.:	Ref.Nr.: 503527
<b>F8-6134</b>	<b>F8-6394</b>	<b>F8-6500</b>	<b>F8-6593</b>	<b>F8-7169</b>	<b>F8-7585</b>	<b>LM-10040S</b>
Ref.Nr.: 3523.91	Ref.Nr.: 0515.R8	Ref.Nr.: 1844.36	Ref.Nr.: 5094.87	Ref.Nr.: 9658296580	Ref.Nr.: 5033.70	Ref.Nr.: 4066.82

**Article Description**

**Article Nr.**
**Fitting Position**

<b>308 SW</b>				<b>09/2007 →</b>	
Engine Mounting	2.0 Bioflex		<b>F8-6500</b>		
Mounting, automatic transmission	1.4 16V, 1.6 16V, 1.6 HDi		<b>F8-6505</b>		
Stabiliser Mounting	1.4 16V, 1.6 16V, 1.6 Bioflex, 1.6 HDi, 2.0 Bioflex, 2.0 HDi	Stabi. Diam. [mm]= 21	<b>F8-6593</b>		d=21
Stabiliser Mounting	1.4 16V, 1.6 16V, 1.6 HDi, 2.0 HDi		<b>F8-6594</b>		d=22
Top Strut Mounting	1.4 16V, 1.6 16V, 1.6 Bioflex, 1.6 HDi, 2.0 Bioflex, 2.0 HDi	Aluminium;	<b>F8-7169</b>		H=52; d=10.2; D=62
Rubber Buffer, suspension	1.4 16V, 1.6 16V, 1.6 Bioflex, 1.6 HDi, 2.0 Bioflex, 2.0 HDi		<b>F8-7585</b>		H=96
Bellow, steering	1.4 16V, 1.6 16V, 1.6 Bioflex, 1.6 HDi, 2.0 Bioflex, 2.0 HDi	; ; with clamps;	<b>LM-10040S</b>		d1=17; d2=60; L [mm]=183
<b>309 (10C, 10A)</b>				<b>10/1985 → 12/1989</b>	
Dust Cover Kit, shock absorber	1.1, 1.3, 1.4, 1.5, 1.6, 1.9, 1.9 D, 1.9 GTI		<b>AK-735010</b>		
Anti-Friction Bearing	1.1, 1.3, 1.4, 1.5, 1.6, 1.6 CAT, 1.9, 1.9 D, 1.9 GTI		<b>F8-3012</b>		H=20; d=66; D=100
Engine Mounting	1.6, 1.9, 1.9 D, 1.9 GTI		<b>F8-5026</b>		d=10; D=70; Thick. [mm]=40, 53
Control Arm-/Trailing Arm Bush	1.9, 1.9 GTI		<b>F8-5072</b>		d=12; D=42; W=38
Bellow, driveshaft	1.4	Transmission Type: BE1, BE3, MA	<b>F8-5356</b>		D1=72; D219; L=172
Bellow, driveshaft	1.4	Transmission Type: MA	<b>F8-5356</b>		D1=72; D219; L=172
Bellow, driveshaft	1.9 D, 1.9 GTI		<b>F8-5356</b>		D1=72; D219; L=172
Engine Mounting	1.1, 1.3, 1.6, 1.6 CAT, 1.9, 1.9 GTI		<b>F8-5358</b>		
Engine Mounting	1.4	Grey Cast Iron	<b>F8-5358</b>		
Engine Mounting	1.9 D	01/1988 →	<b>F8-5358</b>		
Engine Mounting	1.1, 1.3, 1.3 XL, 1.4, 1.6, 1.6 CAT, 1.9, 1.9 GTI		<b>F8-5375</b>		H=34; d=12; D=30
Engine Mounting	1.9 D	01/1988 →	<b>F8-5375</b>		H=34; d=12; D=30
Top Strut Mounting	1.1, 1.3, 1.4, 1.5, 1.6, 1.6 CAT, 1.9, 1.9 D, 1.9 GTI		<b>F8-5520</b>		
Engine Mounting	1.1, 1.3, 1.4, 1.5, 1.6, 1.6 CAT, 1.9, 1.9 D, 1.9 GTI		<b>F8-5555</b>		
Engine Mounting	1.1, 1.3, 1.4, 1.5, 1.6, 1.6 CAT, 1.9, 1.9 D, 1.9 GTI		<b>F8-5556</b>		
Engine Mounting	1.1, 1.3	07/1987 →	<b>F8-5558</b>		
Engine Mounting	1.3 XL, 1.4, 1.6, 1.6 CAT, 1.9, 1.9 D, 1.9 GTI		<b>F8-5558</b>		
Engine Mounting	1.4	TU3M	<b>F8-5558</b>		
Mounting, axle beam	1.1, 1.3, 1.3 XL, 1.4, 1.6, 1.6 CAT, 1.9, 1.9 D, 1.9 GTI		<b>F8-5566</b>		
Belt Pulley, crankshaft	1.9 D		<b>F8-5646</b>		
Rubber Buffer, suspension	1.1, 1.3, 1.4, 1.6, 1.6 CAT, 1.9, 1.9 GTI		<b>F8-5798</b>		L=57
Mounting, axle beam	1.9 D		<b>F8-5852</b>		H=30; D=11.5
Repair Kit, wheel suspension	1.1, 1.3, 1.3 XL, 1.4, 1.5, 1.6, 1.6 CAT, 1.9, 1.9 D, 1.9 GTI		<b>F8-6272</b>		

<b>AK-735010</b>	<b>F8-3012</b>	<b>F8-5026</b>	<b>F8-5072</b>	<b>F8-5356</b>	<b>F8-5358</b>	<b>F8-5375</b>
Ref.Nr.: <b>AK-735010</b>	Ref.Nr.: <b>503527</b>	Ref.Nr.: <b>9606121080</b>	Ref.Nr.: <b>3523.23</b>	Ref.Nr.: <b>328769</b>	Ref.Nr.: <b>184373</b>	Ref.Nr.: <b>180906</b>
<b>F8-5520</b>	<b>F8-5555</b>	<b>F8-5556</b>	<b>F8-5558</b>	<b>F8-5566</b>	<b>F8-5646</b>	<b>F8-5798</b>
Ref.Nr.: <b>503518</b>	Ref.Nr.: <b>97521102</b>	Ref.Nr.: <b>1843.95</b>	Ref.Nr.: <b>1843.97</b>	Ref.Nr.: <b>515110</b>	Ref.Nr.: <b>0515K9</b>	Ref.Nr.: <b>5033.23</b>
<b>F8-5852</b>	<b>F8-6272</b>	<b>F8-6487</b>	<b>F8-6500</b>	<b>F8-6505</b>	<b>F8-6593</b>	<b>F8-6594</b>
Ref.Nr.: <b>5131.47</b>	Ref.Nr.: <b>9556384280</b>	Ref.Nr.: <b>184472</b>	Ref.Nr.: <b>1844.36</b>	Ref.Nr.: <b>1844.51</b>	Ref.Nr.: <b>5094.87</b>	Ref.Nr.: <b>509488</b>



**Article Description****Article Nr.****Fitting Position****309 (10C, 10A)****10/1985 → 12/1989**

Engine Mounting	1.4		<b>F8-6487</b>		
Engine Mounting	1.4	TU3M	<b>F8-6487</b>		
Stabiliser Mounting	1.1, 1.3, 1.4, 1.5, 1.6, 1.6 CAT, 1.9, 1.9 D, 1.9 GTI	Stabi. Diam. [mm]= 20	<b>F8-6793</b>		d=18
Stabiliser Mounting	1.1, 1.3, 1.4, 1.5, 1.6, 1.6 CAT, 1.9, 1.9 D, 1.9 GTI	Stabi. Diam. [mm]= 22	<b>F8-6794</b>		d=22
Stabiliser Mounting	1.1, 1.3, 1.3 XL, 1.4, 1.5, 1.6, 1.6 CAT, 1.9, 1.9 D, 1.9 GTI		<b>F8-6795</b>		D=23; d=22
Repair Kit, wheel suspension	1.1, 1.3, 1.3 XL, 1.4, 1.5, 1.6, 1.6 CAT, 1.9, 1.9 D, 1.9 GTI		<b>G8-272</b>		
Control Arm-/Trailing Arm Bush	1.1, 1.3, 1.4, 1.5, 1.6, 1.6 CAT, 1.9, 1.9 D		<b>G9-523</b>		H=25; d=12; D1=36; D2=47
Repair Kit, link	1.1, 1.3, 1.4, 1.5, 1.6, 1.6 CAT, 1.9, 1.9 D		<b>G9-523S</b>		H=25; d=12; D1=36; D2=47
Control Arm-/Trailing Arm Bush	1.1, 1.3, 1.4, 1.5, 1.6, 1.6 CAT, 1.9, 1.9 D		<b>G9-525</b>		H=34; d=10; D=28
Control Arm-/Trailing Arm Bush	1.9 D		<b>G9-547</b>		d=12; D=33; W=38
Control Arm-/Trailing Arm Bush	1.9 D		<b>G9-549</b>		
Bellow, steering	1.1, 1.3, 1.4, 1.5, 1.6, 1.6 CAT, 1.9, 1.9 D, 1.9 GTI	with clamps;	<b>LM-10004S</b>		d1=10; d2=40; L [mm]=175
Bellow, steering	1.1, 1.3, 1.4, 1.5, 1.6, 1.6 CAT, 1.9, 1.9 D, 1.9 GTI	; with clamps;	<b>LM-10004S</b>		d1=10; d2=40; L [mm]=175
Bellow, steering	1.1, 1.3, 1.4, 1.5, 1.6, 1.6 CAT, 1.9, 1.9 D, 1.9 GTI	; with clamps;	<b>LM-10004S</b>		d1=10; d2=40; L [mm]=175
Bellow, steering	1.1, 1.4, 1.6, 1.6 CAT, 1.9, 1.9 GTI	with clamps;	<b>LM-10039S</b>		d1=40; d2=40; L [mm]=115
Bellow, steering	1.3	G1A; with clamps;	<b>LM-10039S</b>		d1=40; d2=40; L [mm]=115
Bellow, steering	1.3 XL	G2; with clamps;	<b>LM-10039S</b>		d1=40; d2=40; L [mm]=115
Bellow, steering	1.4	TU3M; with clamps;	<b>LM-10039S</b>		d1=40; d2=40; L [mm]=115
Bellow, steering	1.5	Y2; with clamps;	<b>LM-10039S</b>		d1=40; d2=40; L [mm]=115
Bellow, steering	1.6	XU5J; with clamps;	<b>LM-10039S</b>		d1=40; d2=40; L [mm]=115
Bellow, steering	1.9 D	XUD9; with clamps;	<b>LM-10039S</b>		d1=40; d2=40; L [mm]=115
Bellow, steering	1.9 GTI	XU9JA; with clamps;	<b>LM-10039S</b>		d1=40; d2=40; L [mm]=115

**309 Mk II (3C, 3A)****07/1989 → 12/1993**

Dust Cover Kit, shock absorber	1.1, 1.4, 1.6, 1.8 Diesel, 1.9, 1.9 Diesel, 1.9 GTI		<b>AK-735010</b>		
Anti-Friction Bearing	1.1, 1.4, 1.6, 1.6 GTI, 1.8 Diesel, 1.8 TD, 1.9, 1.9 Diesel, 1.9 GTI, 1.9 GTI 16V		<b>F8-3012</b>		H=20; d=66; D=100
Engine Mounting	1.6, 1.9 GTI 16V		<b>F8-5026</b>		d=10; D=70; Thick. [mm]=40, 53
Control Arm-/Trailing Arm Bush	1.9, 1.9 GTI, 1.9 GTI 16V		<b>F8-5072</b>		d=12; D=42; W=38
Bellow, driveshaft	1.1, 1.4	Transmission Type: MA	<b>F8-5356</b>		D1=72; D219; L=172
Bellow, driveshaft	1.6	Transmission Type: BE1, BE3	<b>F8-5356</b>		D1=72; D219; L=172
Bellow, driveshaft	1.8 TD, 1.9 Diesel, 1.9 GTI		<b>F8-5356</b>		D1=72; D219; L=172

<b>AK-735010</b>	<b>F8-3012</b>	<b>F8-5026</b>	<b>F8-5072</b>	<b>F8-5356</b>	<b>F8-5358</b>	<b>F8-6487</b>
Ref.Nr.:	Ref.Nr.: 503527	Ref.Nr.: 9606121080	Ref.Nr.: 3523.23	Ref.Nr.: 328769	Ref.Nr.: 184373	Ref.Nr.: 184472
<b>F8-6793</b>	<b>F8-6794</b>	<b>F8-6795</b>	<b>G8-272</b>	<b>G9-523</b>	<b>G9-523S</b>	<b>G9-525</b>
Ref.Nr.: 5094.36	Ref.Nr.: 5094.37	Ref.Nr.: 5094.40	Ref.Nr.: 5132.49	Ref.Nr.: 3523.25	Ref.Nr.: 3523.25	Ref.Nr.: 3523.31
<b>G9-547</b>	<b>G9-549</b>	<b>LM-10004S</b>	<b>LM-10039S</b>			
Ref.Nr.: 3523.40	Ref.Nr.: 3523.42	Ref.Nr.: 7910030073	Ref.Nr.: 4066.22			

Article Description



Article Nr.

Fitting Position



### 309 Mk II (3C, 3A)

07/1989 → 12/1993

Article Description	Engine	Material	Article Nr.	Fitting Position	Dimensions
Engine Mounting	1.1, 1.4	Grey Cast Iron	F8-5358		
Engine Mounting	1.6, 1.8 Diesel, 1.9, 1.9 GTI, 1.9 GTI 16V		F8-5358		
Engine Mounting	1.1, 1.4, 1.6, 1.6 GTI, 1.8 Diesel, 1.9, 1.9 Diesel, 1.9 GTI, 1.9 GTI 16V		F8-5375		H=34; d=12; D=30
Top Strut Mounting	1.1, 1.4, 1.6, 1.6 GTI, 1.8 Diesel, 1.8 TD, 1.9, 1.9 Diesel, 1.9 GTI, 1.9 GTI 16V		F8-5520		
Engine Mounting	1.1, 1.4, 1.6, 1.8 Diesel, 1.9, 1.9 Diesel, 1.9 GTI, 1.9 GTI 16V		F8-5556		
Engine Mounting	1.1, 1.4, 1.6, 1.6 GTI, 1.8 Diesel, 1.8 TD, 1.9, 1.9 Diesel, 1.9 GTI, 1.9 GTI 16V		F8-5558		
Engine Mounting	1.4	TU3M	F8-5558		
Engine Mounting	1.6	XU5M	F8-5558		
Mounting, axle beam	1.1, 1.4, 1.6, 1.6 GTI, 1.8 Diesel, 1.9, 1.9 Diesel, 1.9 GTI, 1.9 GTI 16V		F8-5566		
Belt Pulley, crankshaft	1.8 Diesel, 1.9 Diesel		F8-5646		
Rubber Buffer, suspension	1.1, 1.4, 1.6, 1.8 Diesel, 1.9, 1.9 GTI, 1.9 GTI 16V		F8-5798		L=57
Repair Kit, wheel suspension	1.1, 1.4, 1.6, 1.6 GTI, 1.8 Diesel, 1.8 TD, 1.9, 1.9 Diesel, 1.9 GTI, 1.9 GTI 16V		F8-6272		
Engine Mounting	1.1, 1.4		F8-6487		
Engine Mounting	1.4	TU3M	F8-6487		
Stabiliser Mounting	1.1, 1.4, 1.6, 1.8 Diesel, 1.8 TD, 1.9, 1.9 Diesel, 1.9 GTI, 1.9 GTI 16V	Stabi. Diam. [mm]= 20	F8-6793		d=18
Stabiliser Mounting	1.1, 1.4, 1.6, 1.8 Diesel, 1.8 TD, 1.9, 1.9 Diesel, 1.9 GTI, 1.9 GTI 16V	Stabi. Diam. [mm]= 22	F8-6794		d=22
Stabiliser Mounting	1.1, 1.4, 1.6, 1.6 GTI, 1.8 Diesel, 1.8 TD, 1.9, 1.9 Diesel, 1.9 GTI, 1.9 GTI 16V		F8-6795		D=23; d=22
Repair Kit, wheel suspension	1.1, 1.4, 1.6, 1.6 GTI, 1.8 Diesel, 1.8 TD, 1.9, 1.9 Diesel, 1.9 GTI, 1.9 GTI 16V		G8-272		
Control Arm-/Trailing Arm Bush	1.1, 1.4, 1.6, 1.8 Diesel, 1.9, 1.9 Diesel		G9-523		H=25; d=12; D1=36; D2=47
Repair Kit, link	1.1, 1.4, 1.6, 1.8 Diesel, 1.9, 1.9 Diesel		G9-523S		H=25; d=12; D1=36; D2=47
Control Arm-/Trailing Arm Bush	1.1, 1.4, 1.6, 1.8 Diesel, 1.9, 1.9 Diesel		G9-525		H=34; d=10; D=28
Bellow, steering	1.1, 1.4, 1.6, 1.8 Diesel, 1.8 TD, 1.9, 1.9 Diesel, 1.9 GTI, 1.9 GTI 16V	with clamps;	LM-10004S		d1=10; d2=40; L [mm]=175
Bellow, steering	1.1, 1.4, 1.6, 1.8 Diesel, 1.8 TD, 1.9, 1.9 Diesel, 1.9 GTI, 1.9 GTI 16V	; with clamps;	LM-10004S		d1=10; d2=40; L [mm]=175
Bellow, steering	1.1, 1.4, 1.6, 1.8 Diesel, 1.8 TD, 1.9, 1.9 Diesel, 1.9 GTI, 1.9 GTI 16V	; with clamps;	LM-10004S		d1=10; d2=40; L [mm]=175
Bellow, steering	1.1	TU1M; with clamps;	LM-10039S		d1=40; d2=40; L [mm]=115
Bellow, steering	1.1, 1.4, 1.6, 1.9, 1.9 GTI, 1.9 GTI 16V	with clamps;	LM-10039S		d1=40; d2=40; L [mm]=115
Bellow, steering	1.4	TU3M; with clamps;	LM-10039S		d1=40; d2=40; L [mm]=115



**Article Description****Article Nr.****Fitting Position**

<b>309 Mk II (3C, 3A)</b>				<b>07/1989 → 12/1993</b>	
Bellow, steering	1.6	XU5M; with clamps;	<b>LM-10039S</b>		d1=40; d2=40; L [mm]=115
Bellow, steering	1.6 GTi	XU5JA; with clamps;	<b>LM-10039S</b>		d1=40; d2=40; L [mm]=115
Bellow, steering	1.8 Diesel	XUD7; with clamps;	<b>LM-10039S</b>		d1=40; d2=40; L [mm]=115
Bellow, steering	1.9 Diesel	XUD9; with clamps;	<b>LM-10039S</b>		d1=40; d2=40; L [mm]=115
<b>404</b>				<b>04/1963 → 12/1971</b>	
Dust Cover Kit, shock absorber	All Models	Universal	<b>AK-735147</b>		
<b>404 Convertible</b>				<b>04/1963 → 12/1968</b>	
Dust Cover Kit, shock absorber	All Models	Universal	<b>AK-735147</b>		
<b>405 (15B)</b>				<b>01/1987 → 12/1993</b>	
Dust Cover Kit, shock absorber	1.4, 1.6, 1.8 Turbo Diesel, 1.9, 1.9 4x4, 1.9 Diesel, 1.9 Injection, 1.9 Sport MI-16, 1.9 Sport MI-16 4x4		<b>AK-735010</b>		
Anti-Friction Bearing	All Models		<b>F8-3012</b>		H=20; d=66; D=100
Bellow, driveshaft	1.4	Transmission Type: MA	<b>F8-5356</b>		D1=72; D219; L=172
Bellow, driveshaft	1.6		<b>F8-5356</b>		D1=72; D219; L=172
Bellow, driveshaft	1.9 Diesel	Transmission Type: BE1, BE3	<b>F8-5356</b>		D1=72; D219; L=172
Bellow, driveshaft	1.9 Sport MI-16	Transmission Type: BE1/5, BE3/5	<b>F8-5356</b>		D1=72; D219; L=172
Engine Mounting	1.6, 1.9, 1.9 Injection, 1.9 Sport MI-16	01/1988 →	<b>F8-5358</b>		
Engine Mounting	1.8 Turbo Diesel, 1.9, 1.9 4x4, 1.9 Diesel, 1.9 Sport MI-16, 1.9 Sport MI-16 4x4		<b>F8-5358</b>		
Engine Mounting	1.4, 1.6, 1.6 4x4, 1.8 D 4x4, 1.8 Turbo Diesel, 1.9, 1.9 4x4, 1.9 Diesel, 1.9 Sport MI-16, 1.9 Sport MI-16 4x4		<b>F8-5375</b>		H=34; d=12; D=30
Engine Mounting	1.6, 1.9, 1.9 Injection, 1.9 Sport MI-16	01/1988 →	<b>F8-5375</b>		H=34; d=12; D=30
Top Strut Mounting	1.4, 1.6, 1.9		<b>F8-5508</b>		
Top Strut Mounting	1.6, 1.8 Turbo Diesel, 1.9, 1.9 4x4, 1.9 Diesel, 1.9 Injection, 1.9 Sport MI-16, 1.9 Sport MI-16 4x4	ch.8026775→; ch.→70613611;	<b>F8-5508</b>		
Engine Mounting	1.6, 1.8 Turbo Diesel, 1.9, 1.9 4x4, 1.9 Diesel, 1.9 Injection, 1.9 Sport MI-16, 1.9 Sport MI-16 4x4		<b>F8-5556</b>		
Engine Mounting	1.4, 1.6, 1.6 4x4, 1.8 D 4x4, 1.9, 1.9 4x4, 1.9 Diesel, 1.9 Sport MI-16, 1.9 Sport MI-16 4x4	ch.→S70514985	<b>F8-5558</b>		
Engine Mounting	1.6	ch.→S70514985; 01/1988 →;  XU51C	<b>F8-5558</b>		
Engine Mounting	1.6	ch.→S70514985; 01/1988 →;  XU5M	<b>F8-5558</b>		
Engine Mounting	1.6, 1.9, 1.9 Injection, 1.9 Sport MI-16	ch.→S70514985; 01/1988 →	<b>F8-5558</b>		
Engine Mounting	1.8 Turbo Diesel	ch.→S70514985;  XUD7TE	<b>F8-5558</b>		
Engine Mounting	1.9 4x4		<b>F8-5558</b>		
Engine Mounting	1.6	ch.S70514985→; 04/1988 →;  XU5M	<b>F8-5568</b>		
Engine Mounting	1.6	ch.S70514985→; 09/1988 →	<b>F8-5568</b>		
Engine Mounting	1.6, 1.9 4x4, 1.9 Diesel		<b>F8-5568</b>		



Article Description



Article Nr.

Fitting Position



405 (15B)			01/1987 → 12/1993		
Engine Mounting	1.6, 1.9, 1.9 Injection, 1.9 Sport MI-16, 1.9 SPort MI-16 4x4	ch.S70514985→	F8-5568	⊕	
Engine Mounting	1.8 Turbo Diesel, 1.9 Diesel	ch.S70514984→	F8-5568	⊕	
Engine Mounting	1.9	08/1992 →	F8-5568	⊕	
Engine Mounting	1.6, 1.9		F8-5569	⊕	
Belt Pulley, crankshaft	1.8 D 4x4	Number of Ribs: 6;	F8-5643		Belt Pulley Ø [mm]=156; W=44
Belt Pulley, crankshaft	1.8 Turbo Diesel	XUD7TE; Number of Ribs: 6	F8-5643		Belt Pulley Ø [mm]=156; W=44
Belt Pulley, crankshaft	1.9 Diesel	Number of Ribs: 6	F8-5643		Belt Pulley Ø [mm]=156; W=44
Belt Pulley, crankshaft	1.9 Diesel	Number of Ribs: 6;	F8-5643		Belt Pulley Ø [mm]=156; W=44
Belt Pulley, crankshaft	1.9 Diesel		F8-5646		
Mounting, axle beam	1.4, 1.6, 1.8 Turbo Diesel, 1.9, 1.9 4x4, 1.9 Diesel, 1.9 Injection, 1.9 Sport MI-16, 1.9 SPort MI-16 4x4		F8-5852	⊕ ⊕	H=30; D=11.5
Rubber Buffer, suspension	1.4, 1.6, 1.6 4x4, 1.8 D 4x4, 1.8 Turbo Diesel, 1.9, 1.9 4x4, 1.9 Diesel, 1.9 Injection, 1.9 Sport MI-16, 1.9 SPort MI-16 4x4		F8-6064		L=79
Repair Kit, wheel suspension	1.4, 1.6, 1.6 4x4, 1.8 Turbo Diesel, 1.9, 1.9 4x4, 1.9 Diesel, 1.9 Injection, 1.9 Sport MI-16, 1.9 SPort MI-16 4x4		F8-6276		
Top Strut Mounting	1.4, 1.6, 1.8 Turbo Diesel, 1.9, 1.9 4x4, 1.9 Diesel, 1.9 Injection, 1.9 Sport MI-16, 1.9 SPort MI-16 4x4	07/1992 →;	F8-6294		
Top Strut Mounting	1.4, 1.6, 1.8 Turbo Diesel, 1.9, 1.9 4x4, 1.9 Diesel, 1.9 Injection, 1.9 Sport MI-16, 1.9 SPort MI-16 4x4		F8-6295		
Engine Mounting	1.4	01/1988 →	F8-6487	⊕	
Mounting, axle bracket	1.6, 1.9 Sport MI-16		F8-7043	⊕ ⊕	
Mounting, axle bracket	1.9	08/1992 →	F8-7043	⊕ ⊕	
Top Strut Mounting	All Models	ch.S70613612→;	F8-7153	⊕ ⊕	
Stabiliser Mounting	1.6, 1.8 Turbo Diesel, 1.9, 1.9 4x4, 1.9 Diesel, 1.9 Injection, 1.9 Sport MI-16, 1.9 SPort MI-16 4x4		F8-7212		D=21
Repair Kit, wheel suspension	1.4, 1.6, 1.6 4x4, 1.8 Turbo Diesel, 1.9, 1.9 4x4, 1.9 Diesel, 1.9 Injection, 1.9 Sport MI-16, 1.9 SPort MI-16 4x4		G8-276-5017	⊕ ⊕	H=197; d=34; D=50,17
Repair Kit, wheel suspension	1.4, 1.6, 1.6 4x4, 1.8 Turbo Diesel, 1.9, 1.9 4x4, 1.9 Diesel, 1.9 Injection, 1.9 Sport MI-16, 1.9 SPort MI-16 4x4		G8-276-5020	⊕ ⊕	H=197; d=34; D=50,2
Control Arm-/Trailing Arm Bush	1.4, 1.6, 1.8 Turbo Diesel, 1.9, 1.9 4x4, 1.9 Diesel, 1.9 Injection, 1.9 Sport MI-16, 1.9 SPort MI-16 4x4		G9-547	⊕ ⊕ ⊕ ↓	d=12; D=33; W=38
Control Arm-/Trailing Arm Bush	1.4, 1.6, 1.8 Turbo Diesel, 1.9, 1.9 4x4, 1.9 Diesel, 1.9 Injection, 1.9 Sport MI-16, 1.9 SPort MI-16 4x4		G9-549	⊕ ⊕ ⊕ ↓	
405 Estate (15E)			06/1987 → 08/1992		
Dust Cover Kit, shock absorber	1.6, 1.8 TD, 1.9, 1.9 4x4, 1.9 D		AK-735010	⊕ ⊕	

<b>AK-735010</b>	<b>F8-3012</b>	<b>F8-5568</b>	<b>F8-5569</b>	<b>F8-5643</b>	<b>F8-5646</b>	<b>F8-5852</b>
Ref.Nr.:	Ref.Nr.: 503527	Ref.Nr.: 184425	Ref.Nr.: 9604338880	Ref.Nr.: 96089 38980	Ref.Nr.: 0515K9	Ref.Nr.: 5131.47
<b>F8-6064</b>	<b>F8-6276</b>	<b>F8-6294</b>	<b>F8-6295</b>	<b>F8-6487</b>	<b>F8-7043</b>	<b>F8-7153</b>
Ref.Nr.: 5033.26	Ref.Nr.: 9612314280	Ref.Nr.: 503735	Ref.Nr.: 91510633	Ref.Nr.: 184472	Ref.Nr.: 5151.24	Ref.Nr.: 503726
<b>F8-7212</b>	<b>G8-276-5017</b>	<b>G8-276-5020</b>	<b>G9-547</b>	<b>G9-549</b>		
Ref.Nr.: 5094.53	Ref.Nr.: 5132.73	Ref.Nr.: 514851	Ref.Nr.: 3523.40	Ref.Nr.: 3523.42		

**Article Description****Article Nr.****Fitting Position**

<b>405 Estate (15E)</b>		<b>06/1987 → 08/1992</b>	
Anti-Friction Bearing	1.4, 1.6, 1.8 DT 4x4, 1.8 GLD, 1.8 TD, 1.9, 1.9 4x4, 1.9 All-wheel Drive, 1.9 D	<b>F8-3012</b>	H=20; d=66; D=100
Engine Mounting	1.6, 1.8 TD, 1.9, 1.9 D	<b>F8-5026</b>	d=10; D=70; Thick. [mm]=40, 53
Engine Mounting	1.9	<b>F8-5026</b>	d=10; D=70; Thick. [mm]=40, 53
Bellow, driveshaft	1.6	<b>F8-5356</b>	D1=72; D219; L=172
Bellow, driveshaft	1.9 D	Transmission Type: BE1, BE3	<b>F8-5356</b>
Engine Mounting	1.6, 1.8 TD, 1.9, 1.9 4x4, 1.9 D	<b>F8-5358</b>	D1=72; D219; L=172
Engine Mounting	1.4, 1.6, 1.6 SRI 4x4, 1.8 DT 4x4, 1.8 GLD, 1.8 TD, 1.9, 1.9 4x4, 1.9 All-wheel Drive, 1.9 D	<b>F8-5375</b>	H=34; d=12; D=30
Top Strut Mounting	1.6, 1.8 TD, 1.9, 1.9 4x4, 1.9 D	ch.8026775→; ch.→70613611;	<b>F8-5508</b>
Top Strut Mounting	1.6, 1.9		<b>F8-5508</b>
Engine Mounting	1.6, 1.8 TD, 1.9, 1.9 4x4, 1.9 D	<b>F8-5556</b>	
Engine Mounting	1.4, 1.6, 1.6 SRI 4x4, 1.8 DT 4x4, 1.8 GLD, 1.9, 1.9 All-wheel Drive, 1.9 D	ch.→S70514985	<b>F8-5558</b>
Engine Mounting	1.6	ch.→S70514985;  XU5M	<b>F8-5558</b>
Engine Mounting	1.8 TD	ch.→S70514985;  XUD7TE	<b>F8-5558</b>
Engine Mounting	1.9 4x4	<b>F8-5558</b>	
Engine Mounting	1.6	ch.S70514985→;  XU5M	<b>F8-5568</b>
Engine Mounting	1.6, 1.9	ch.S70514985→	<b>F8-5568</b>
Engine Mounting	1.6, 1.9, 1.9 4x4, 1.9 D	<b>F8-5568</b>	
Engine Mounting	1.8 TD	ch.S70514984→;  XUD7TE	<b>F8-5568</b>
Engine Mounting	1.9 D	ch.S70514984→	<b>F8-5568</b>
Belt Pulley, crankshaft	1.8 DT 4x4	Number of Ribs: 6;	<b>F8-5643</b>
Belt Pulley, crankshaft	1.8 TD	XUD7TE; Number of Ribs: 6	<b>F8-5643</b>
Belt Pulley, crankshaft	1.9 D	Number of Ribs: 6	<b>F8-5643</b>
Belt Pulley, crankshaft	1.9 D	Number of Ribs: 6;	<b>F8-5643</b>
Belt Pulley, crankshaft	1.9 D		<b>F8-5646</b>
Mounting, axle beam	1.6, 1.8 TD, 1.9, 1.9 4x4, 1.9 D	<b>F8-5852</b>	H=30; D=11.5
Rubber Buffer, suspension	1.4, 1.6, 1.6 SRI 4x4, 1.8 DT 4x4, 1.8 GLD, 1.9, 1.9 4x4, 1.9 All-wheel Drive, 1.9 D	<b>F8-6064</b>	L=79
Rubber Buffer, suspension	1.6	XU5M	<b>F8-6064</b>
Rubber Buffer, suspension	1.8 TD	XUD7TE	<b>F8-6064</b>
Repair Kit, wheel suspension	1.4, 1.6, 1.8 GLD, 1.8 TD, 1.9, 1.9 4x4, 1.9 D	<b>F8-6276</b>	
Top Strut Mounting	1.6, 1.8 TD, 1.9, 1.9 4x4, 1.9 D	07/1992 →;	<b>F8-6294</b>
Top Strut Mounting	1.6, 1.8 TD, 1.9, 1.9 4x4, 1.9 D		<b>F8-6295</b>
Engine Mounting	1.4	<b>F8-6487</b>	
Mounting, axle bracket	1.6	XU5M	<b>F8-7043</b>



Article Description

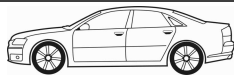

Article Nr.

Fitting Position



405 Estate (15E)		06/1987 → 08/1992	
Mounting, axle bracket	1.6, 1.9, 1.9 4x4, 1.9 D		F8-7043
Mounting, axle bracket	1.8 TD	XUD7TE	F8-7043
Top Strut Mounting	1.4, 1.6, 1.6 SRi 4x4, 1.8 DT 4x4, 1.8 GLD, 1.8 TD, 1.9, 1.9 4x4, 1.9 All-wheel Drive, 1.9 D		F8-7153
Stabiliser Mounting	1.6, 1.8 TD, 1.9, 1.9 4x4, 1.9 D		F8-7212  D=21
Repair Kit, wheel suspension	1.4, 1.6, 1.8 GLD, 1.8 TD, 1.9, 1.9 4x4, 1.9 D		G8-276-5017
Repair Kit, wheel suspension	1.4, 1.6, 1.8 GLD, 1.8 TD, 1.9, 1.9 4x4, 1.9 D		G8-276-5020
Control Arm-/Trailing Arm Bush	1.6, 1.8 TD, 1.9, 1.9 4x4, 1.9 D		G9-547
Control Arm-/Trailing Arm Bush	1.6, 1.8 TD, 1.9, 1.9 4x4, 1.9 D		G9-549
405 Mk II (4B)		08/1992 → 11/1999	
Dust Cover Kit, shock absorber	1.4, 1.6, 1.8, 1.9 D, 1.9 TD, 2.0, 2.0 16V, 2.0 MI-16, 2.0 T 16 X4, 2.0 X4		AK-735010
Anti-Friction Bearing	1.4, 1.6, 1.8, 1.9 D, 1.9 TD, 2.0, 2.0 16V, 2.0 MI-16, 2.0 T 16 X4, 2.0 X4		F8-3012  H=20; d=66; D=100
Bellow, driveshaft	1.6		F8-5356
Bellow, driveshaft	1.9 D	Transmission Type: BE1, BE3	F8-5356
Engine Mounting	1.4	01/1993 →	F8-5358
Engine Mounting	1.6, 1.8, 1.9 D, 1.9 TD, 2.0, 2.0 16V, 2.0 T 16 X4, 2.0 X4		F8-5358
Engine Mounting	1.4, 1.6, 1.8, 1.9 D, 1.9 TD, 2.0, 2.0 16V, 2.0 T 16 X4, 2.0 X4		F8-5375  H=34; d=12; D=30
Top Strut Mounting	1.4, 1.6, 1.8, 1.9 TD, 2.0, 2.0 T 16 X4, 2.0 X4	ch.8026775→; ch.→70613611;	F8-5508
Engine Mounting	1.4, 1.6, 1.8, 1.9 D, 1.9 TD, 2.0, 2.0 16V, 2.0 T 16 X4, 2.0 X4		F8-5558
Engine Mounting	1.4, 1.8, 1.9 D, 1.9 TD, 2.0, 2.0 16V, 2.0 T 16 X4, 2.0 X4	ch.→S70514985	F8-5558
Engine Mounting	1.6	ch.→S70514985;  XU5JP, XU5M	F8-5558
Engine Mounting	1.4, 1.8, 1.9 D, 1.9 TD, 2.0, 2.0 16V, 2.0 T 16 X4		F8-5568
Engine Mounting	1.6	ch.S70514985→;  XU5JP, XU5M	F8-5568
Engine Mounting	2.0 X4	5-speed	F8-5568
Engine Mounting	1.6, 1.8, 1.9 TD, 2.0, 2.0 16V, 2.0 X4		F8-5569
Belt Pulley, crankshaft	1.9 D, 1.9 TD	Number of Ribs: 6	F8-5643  Belt Pulley Ø [mm]=156; W=44
Mounting, axle beam	1.4, 1.6, 1.8, 1.9 D, 1.9 TD, 2.0, 2.0 16V, 2.0 MI-16, 2.0 T 16 X4, 2.0 X4		F8-5852  H=30; D=11.5
Rubber Buffer, suspension	1.4, 1.6, 1.8, 1.9 D, 1.9 TD, 2.0, 2.0 X4		F8-6064  L=79
Engine Mounting	2.0, 2.0 16V, 2.0 X4		F8-6236  H1=53; H2=40; d=10; D=70

<b>AK-735010</b>	<b>F8-3012</b>	<b>F8-5356</b>	<b>F8-5358</b>	<b>F8-5375</b>	<b>F8-5508</b>	<b>F8-5558</b>
Ref.Nr.:	Ref.Nr.: 503527	Ref.Nr.: 328769	Ref.Nr.: 184373	Ref.Nr.: 180906	Ref.Nr.: 503720	Ref.Nr.: 1843.95
<b>F8-5558</b>	<b>F8-5568</b>	<b>F8-5569</b>	<b>F8-5643</b>	<b>F8-5852</b>	<b>F8-6064</b>	<b>F8-6236</b>
Ref.Nr.: 1843.97	Ref.Nr.: 184425	Ref.Nr.: 9604338880	Ref.Nr.: 96089 38980	Ref.Nr.: 5131.47	Ref.Nr.: 5033.26	Ref.Nr.: 1809.21
<b>F8-6276</b>	<b>F8-7043</b>	<b>F8-7153</b>	<b>F8-7212</b>	<b>G8-276-5017</b>	<b>G8-276-5020</b>	<b>G9-547</b>
Ref.Nr.: 9612314280	Ref.Nr.: 5151.24	Ref.Nr.: 503726	Ref.Nr.: 5094.53	Ref.Nr.: 5132.73	Ref.Nr.: 514851	Ref.Nr.: 3523.40

**Article Description****Article Nr.****Fitting Position**

<b>405 Mk II (4B)</b>				<b>08/1992 → 11/1999</b>	
Repair Kit, wheel suspension	1.4, 1.6, 1.8, 1.9 D, 1.9 TD, 2.0, 2.0 16V, 2.0 MI-16, 2.0 T 16 X4, 2.0 X4		<b>F8-6276</b>		
Top Strut Mounting	1.4, 1.6, 1.8, 1.9 D, 1.9 TD, 2.0, 2.0 16V, 2.0 MI-16, 2.0 T 16 X4, 2.0 X4		<b>F8-6294</b>		
Engine Mounting	2.0 T 16 X4	RFN	<b>F8-6507</b>		
Engine Mounting	2.0, 2.0 X4		<b>F8-6507</b>		
Mounting, axle bracket	1.4, 1.8, 1.9 D, 1.9 TD, 2.0, 2.0 16V		<b>F8-7043</b>		
Mounting, axle bracket	1.6	XU5JP, XU5M	<b>F8-7043</b>		
Mounting, axle bracket	2.0 T 16 X4	5-speed	<b>F8-7043</b>		
Belt Pulley, crankshaft	1.6, 2.0, 2.0 X4	Engine 71079955→; Number of Ribs: 6	<b>F8-7084</b>		Belt Pulley Ø [mm]=127; Mounting points diam.[mm]=30; W=45
Belt Pulley, crankshaft	1.8	Engine →71079955; Number of Ribs: 6	<b>F8-7084</b>		Belt Pulley Ø [mm]=127; Mounting points diam.[mm]=30; W=45
Top Strut Mounting	1.4, 1.6, 1.8, 1.9 D, 1.9 TD, 2.0, 2.0 16V, 2.0 MI-16, 2.0 T 16 X4, 2.0 X4	ch.S70613612→;	<b>F8-7153</b>		
Stabiliser Mounting	1.8, 1.9 D, 2.0, 2.0 16V, 2.0 MI-16, 2.0 T 16 X4, 2.0 X4		<b>F8-7212</b>		D=21
Repair Kit, wheel suspension	All Models		<b>G8-276-5017</b>		H=197; d=34; D=50,17
Repair Kit, wheel suspension	All Models		<b>G8-276-5020</b>		H=197; d=34; D=50,2
Control Arm-/Trailing Arm Bush	1.4, 1.6, 1.8, 1.9 D, 1.9 TD, 2.0, 2.0 16V, 2.0 MI-16, 2.0 T 16 X4, 2.0 X4		<b>G9-547</b>		
Control Arm-/Trailing Arm Bush	1.4, 1.6, 1.8, 1.9 D, 1.9 TD, 2.0, 2.0 16V, 2.0 MI-16, 2.0 T 16 X4, 2.0 X4		<b>G9-549</b>		
Bellow, steering	1.4, 1.6, 1.8, 1.9 D, 1.9 TD, 2.0, 2.0 16V, 2.0 MI-16, 2.0 T 16 X4, 2.0 X4	with clamps	<b>LM-10072S</b>		d1=44; d2=44; L [mm]=120
<b>405 Mk II Estate (4E)</b>				<b>08/1992 → 10/1996</b>	
Dust Cover Kit, shock absorber	1.4, 1.6, 1.8, 1.9 D, 1.9 TD, 2.0, 2.0 4x4		<b>AK-735010</b>		
Anti-Friction Bearing	1.4, 1.6, 1.8, 1.9 D, 1.9 TD, 2.0, 2.0 4x4		<b>F8-3012</b>		H=20; d=66; D=100
Engine Mounting	1.6, 1.8, 2.0		<b>F8-5026</b>		d=10; D=70; Thick. [mm]=40, 53
Bellow, driveshaft	1.9 D	Transmission Type: BE1, BE3	<b>F8-5356</b>		
Engine Mounting	1.4	01/1993 →	<b>F8-5358</b>		
Engine Mounting	1.6, 1.8, 1.9 D, 1.9 TD, 2.0, 2.0 4x4		<b>F8-5358</b>		
Engine Mounting	1.4, 1.6, 1.8, 1.9 D, 1.9 TD, 2.0, 2.0 4x4		<b>F8-5375</b>		H=34; d=12; D=30
Top Strut Mounting	1.4, 1.6, 1.8, 1.9 TD, 2.0, 2.0 4x4	ch.8026775→; ch.→70613611;	<b>F8-5508</b>		
Engine Mounting	1.4, 1.6, 1.8, 1.9 D, 1.9 TD, 2.0, 2.0 4x4		<b>F8-5556</b>		
Engine Mounting	1.4, 1.8, 1.9 D, 1.9 TD, 2.0, 2.0 4x4	ch.→S70514985	<b>F8-5558</b>		

<b>AK-735010</b>	<b>F8-3012</b>	<b>F8-5026</b>	<b>F8-5356</b>	<b>F8-5358</b>	<b>F8-5375</b>	<b>F8-5508</b>
Ref.Nr.:	Ref.Nr.: 503527	Ref.Nr.: 9606121080	Ref.Nr.: 328769	Ref.Nr.: 184373	Ref.Nr.: 180906	Ref.Nr.: 503720
<b>F8-5556</b>	<b>F8-5558</b>	<b>F8-6276</b>	<b>F8-6294</b>	<b>F8-6507</b>	<b>F8-7043</b>	<b>F8-7084</b>
Ref.Nr.: 1843.95	Ref.Nr.: 1843.97	Ref.Nr.: 9612314280	Ref.Nr.: 503735	Ref.Nr.: 1827.16	Ref.Nr.: 5151.24	Ref.Nr.: 0515.H6
<b>F8-7153</b>	<b>F8-7212</b>	<b>G8-276-5017</b>	<b>G8-276-5020</b>	<b>G9-547</b>	<b>G9-549</b>	<b>LM-10072S</b>
Ref.Nr.: 503726	Ref.Nr.: 5094.53	Ref.Nr.: 5132.73	Ref.Nr.: 514851	Ref.Nr.: 3523.40	Ref.Nr.: 3523.42	Ref.Nr.: 4066.30

Article Description



Article Nr.

Fitting Position



405 Mk II Estate (4E)			08/1992 → 10/1996		
Engine Mounting	1.6	ch.→S70514985;  XU5JP, XU5M	F8-5558		
Engine Mounting	1.4, 1.8, 1.9 D, 1.9 TD, 2.0		F8-5568		
Engine Mounting	1.6	ch.S70514985→;  XU5JP, XU5M	F8-5568		
Engine Mounting	2.0 4x4	5-speed	F8-5568		
Engine Mounting	1.6, 1.8, 1.9 TD, 2.0 4x4		F8-5569		
Belt Pulley, crankshaft	1.9 D, 1.9 TD	Number of Ribs: 6	F8-5643		Belt Pulley Ø [mm]=156; W=44
Mounting, axle beam	1.4, 1.6, 1.8, 1.9 D, 1.9 TD, 2.0, 2.0 4x4		F8-5852		H=30; D=11.5
Rubber Buffer, suspension	1.4, 1.8, 1.9 D, 1.9 TD, 2.0, 2.0 4x4		F8-6064		L=79
Rubber Buffer, suspension	1.6	XU5JP	F8-6064		L=79
Engine Mounting	2.0, 2.0 4x4		F8-6236		H1=53; H2=40; d=10; D=70
Repair Kit, wheel suspension	1.4, 1.6, 1.8, 1.9 D, 1.9 TD, 2.0, 2.0 4x4		F8-6276		
Top Strut Mounting	1.4, 1.6, 1.8, 1.9 D, 1.9 TD, 2.0, 2.0 4x4		F8-6294		
Engine Mounting	2.0 4x4		F8-6507		
Engine Mounting	2.0, 2.0 4x4		F8-6507		
Mounting, axle bracket	1.4, 1.8, 1.9 TD, 2.0		F8-7043		
Mounting, axle bracket	1.6	XU5JP, XU5M	F8-7043		
Mounting, axle bracket	2.0 4x4		F8-7043		
Belt Pulley, crankshaft	1.6, 2.0, 2.0 4x4	Engine71079955→; Number of Ribs: 6	F8-7084		Belt Pulley Ø [mm]=127; Mounting points diam.[mm]=30; W=45
Belt Pulley, crankshaft	1.8	Engine →71079955; Number of Ribs: 6	F8-7084		Belt Pulley Ø [mm]=127; Mounting points diam.[mm]=30; W=45
Top Strut Mounting	1.4, 1.6, 1.8, 1.9 D, 1.9 TD, 2.0, 2.0 4x4	ch.S70613612→;	F8-7153		
Stabiliser Mounting	1.4, 1.6, 1.8, 1.9 D, 1.9 TD, 2.0, 2.0 4x4		F8-7212		D=21
Repair Kit, wheel suspension	1.4, 1.6, 1.8, 1.9 D, 1.9 TD, 2.0, 2.0 4x4		G8-276-5017		H=197; d=34; D=50,17
Repair Kit, wheel suspension	1.4, 1.6, 1.8, 1.9 D, 1.9 TD, 2.0, 2.0 4x4		G8-276-5020		H=197; d=34; D=50,2
Control Arm-/Trailing Arm Bush	1.4, 1.6, 1.8, 1.9 D, 1.9 TD, 2.0, 2.0 4x4		G9-547		d=12; D=33; W=38
Control Arm-/Trailing Arm Bush	1.4, 1.6, 1.8, 1.9 D, 1.9 TD, 2.0, 2.0 4x4		G9-549		
Bellow, steering	1.4, 1.6, 1.8, 1.9 D, 1.9 TD, 2.0, 2.0 4x4	with clamps	LM-10072S		d1=44; d2=44; L [mm]=120
406 (8B)			11/1995 → 06/2004		
Dust Cover Kit, shock absorber	1.6, 1.8, 1.8 16V, 1.9 D	ch.07812→	AK-735064		





**Article Description****Article Nr.****Fitting Position**

<b>406 (8B)</b>			<b>11/1995 → 06/2004</b>		
Dust Cover Kit, shock absorber	1.8 16V, 1.9 TD, 2.0 16V HPI, 2.0 HDi 110, 2.0 HDi 90, 2.0 Turbo, 2.1 TD 12V, 2.2, 2.2 HDi, 3.0 24V, 3.0 V6		<b>AK-735064</b>		
Dust Cover Kit, shock absorber	2.0 16V, 2.0 HDi 110	ch.08547→	<b>AK-735064</b>		
Dust Cover Kit, shock absorber	1.6, 1.8, 1.8 16V, 1.9 D	ch.→07811	<b>AK-735096</b>		
Dust Cover Kit, shock absorber	1.9 TD, 2.0 HDi 90, 2.0 Turbo, 2.1 TD 12V, 2.2, 2.2 HDi, 3.0 24V, 3.0 V6		<b>AK-735096</b>		
Dust Cover Kit, shock absorber	2.0 16V, 2.0 HDi 110	ch.→08546	<b>AK-735096</b>		
Alternator Freewheel Clutch	2.0 HDi 110, 2.0 HDi 90, 2.2 HDi		<b>F5-1020</b>		
Alternator Freewheel Clutch	2.0 HDi 110, 2.0 HDi 90, 2.2 HDi		<b>F5-1046</b>		
Alternator Freewheel Clutch	2.2 HDi		<b>F5-1048</b>		
Engine Mounting	1.6	01/1996 →	<b>F8-5026</b>		d=10; D=70; Thick. [mm]=40, 53
Engine Mounting	1.8		<b>F8-5026</b>		d=10; D=70; Thick. [mm]=40, 53
Control Arm-/Trailing Arm Bush	1.6, 1.8, 1.8 16V, 1.9 D, 1.9 TD, 2.0 16V, 2.0 16V HPI, 2.0 HDi 110, 2.0 HDi 90, 2.0 Turbo, 2.1 TD 12V, 2.2, 2.2 HDi, 3.0 24V, 3.0 V6		<b>F8-5066</b>		H1=38; H2=32; d=14; D=37
Control Arm-/Trailing Arm Bush	1.6, 1.8, 1.8 16V, 1.9 D, 1.9 TD, 2.0 16V, 2.0 16V HPI, 2.0 HDi 110, 2.0 HDi 90, 2.0 Turbo, 2.1 TD 12V, 2.2, 2.2 HDi, 3.0 24V, 3.0 V6		<b>F8-5099</b>		d=20; L=114; D=55; M12 x 1,50 RHT
Engine Mounting	1.6, 1.8, 1.9 TD, 2.0 Turbo	Orga.→7966	<b>F8-5359</b>		
Engine Mounting	1.8 16V, 2.0 16V	Orga.→7966;	<b>F8-5359</b>		
Engine Mounting	1.6, 1.8, 1.8 16V, 1.9 D, 1.9 TD, 2.1 TD 12V, 2.2 HDi, 3.0 24V, 3.0 V6		<b>F8-5375</b>		H=34; d=12; D=30
Engine Mounting	1.9 TD	ch.→O07967	<b>F8-5375</b>		H=34; d=12; D=30
Engine Mounting	1.6, 1.8, 1.8 16V, 2.0 16V		<b>F8-5556</b>		
Engine Mounting	1.8 16V, 1.9 D, 1.9 TD, 2.0 16V, 2.0 HDi 90		<b>F8-5569</b>		
Control Arm-/Trailing Arm Bush	1.6, 1.8, 1.8 16V, 1.9 D, 1.9 TD, 2.0, 2.0 16V, 2.0 Turbo, 2.1 TD 12V, 3.0 24V	11/1997 →; Orga.07665→	<b>F8-5630</b>		H=57; d=14; D=45
Control Arm-/Trailing Arm Bush	1.8 16V, 2.0 16V, 2.0 16V HPI, 2.0 HDi 110, 2.0 HDi 90, 2.2, 2.2 HDi, 3.0 V6		<b>F8-5630</b>		H=57; d=14; D=45
Belt Pulley, crankshaft	2.0 HDi 110	Orga.→09337	<b>F8-5636</b>		d=30
Belt Pulley, crankshaft	2.0 HDi 110	Orga.→09337;	<b>F8-5636</b>		d=30
Belt Pulley, crankshaft	2.0 HDi 110	Orga.→09365	<b>F8-5636</b>		d=30
Belt Pulley, crankshaft	2.0 HDi 110	Orga.→09365;	<b>F8-5636</b>		d=30
Belt Pulley, crankshaft	2.2 HDi		<b>F8-5636</b>		d=30
Belt Pulley, crankshaft	1.9 D, 1.9 TD	Number of Ribs: 6	<b>F8-5643</b>		Belt Pulley Ø [mm]=156; W=44
Belt Pulley, crankshaft	2.1 TD 12V		<b>F8-5647</b>		
Belt Pulley, crankshaft	2.0 HDi 110	ch.O09338, O09366→;	<b>F8-5660</b>		
Belt Pulley, crankshaft	2.0 HDi 110	Orga.09338→;	<b>F8-5660</b>		



Article Description



Article Nr.

Fitting Position



406 (8B)			11/1995 → 06/2004		
Belt Pulley, crankshaft	2.0 HDi 110	Orga.09366→;	<b>F8-5660</b>		
Belt Pulley, crankshaft	2.0 HDi 90	12/2002 →;	<b>F8-5660</b>		
Control Arm-/Trailing Arm Bush	1.6, 1.8, 1.8 16V, 1.9 D, 1.9 TD, 2.0, 2.0 16V, 2.0 Turbo, 2.1 TD 12V, 2.2, 2.2 HDi, 3.0 24V, 3.0 V6	Orga.→07664	<b>F8-5669</b>		H=56.8; d=14; D=45
Mounting, axle beam	1.6, 1.8, 1.8 16V, 1.9 D, 1.9 TD, 2.0 16V, 2.0 16V HPi, 2.0 HDi 110, 2.0 HDi 90, 2.0 Turbo, 2.1 TD 12V, 2.2, 2.2 HDi, 3.0 24V, 3.0 V6		<b>F8-5807</b>		d=14; D=40
Control Arm-/Trailing Arm Bush	1.6, 1.8, 1.8 16V, 1.9 D, 1.9 TD, 2.0 16V, 2.0 16V HPi, 2.0 HDi 110, 2.0 HDi 90, 2.0 Turbo, 2.1 TD 12V, 2.2, 2.2 HDi, 3.0 24V, 3.0 V6		<b>F8-5828</b>		d=12; D=41; Total Br. Drum Height [mm]=41
Control Arm-/Trailing Arm Bush	1.6, 1.8, 1.8 16V, 1.9 D, 1.9 TD, 2.0 16V, 2.0 16V HPi, 2.0 HDi 110, 2.0 HDi 90, 2.0 Turbo, 2.1 TD 12V, 2.2, 2.2 HDi, 3.0 24V, 3.0 V6		<b>F8-5829</b>		H1=65; H2=46; d=14; D=56
Control Arm-/Trailing Arm Bush	1.6, 1.8, 1.8 16V, 1.9 D, 1.9 TD, 2.0 16V, 2.0 16V HPi, 2.0 HDi 110, 2.0 HDi 90, 2.0 Turbo, 2.1 TD 12V, 2.2, 2.2 HDi, 3.0 24V, 3.0 V6		<b>F8-5830</b>		H1=60; H2=48; d=12; D=32
Rubber Buffer, suspension	1.6, 1.8, 1.8 16V, 1.9 D, 1.9 TD, 2.0, 2.0 16V, 2.0 16V HPi, 2.0 HDi 110, 2.0 HDi 90, 2.0 Turbo, 2.1 TD 12V, 2.2, 2.2 HDi, 3.0 24V, 3.0 V6		<b>F8-5935</b>		H=109
Top Strut Mounting	1.6, 1.8, 1.8 16V, 1.9 D, 1.9 TD, 2.0, 2.0 16V, 2.0 16V HPi, 2.0 HDi 110, 2.0 HDi 90, 2.0 Turbo, 2.1 TD 12V, 2.2, 2.2 HDi, 3.0 24V, 3.0 V6		<b>F8-6026</b>		
Stabiliser Mounting	1.6, 1.8, 1.8 16V, 1.9 D, 1.9 TD, 2.0, 2.0 16V, 2.0 16V HPi, 2.0 HDi 110, 2.0 HDi 90, 2.0 Turbo, 2.1 TD 12V, 2.2, 2.2 HDi, 3.0 24V, 3.0 V6		<b>F8-6130</b>		d=23
Stabiliser Mounting	1.6, 1.8, 1.8 16V, 1.9 D, 1.9 TD, 2.0, 2.0 16V, 2.0 16V HPi, 2.0 HDi 110, 2.0 HDi 90, 2.0 Turbo, 2.1 TD 12V, 2.2, 2.2 HDi, 3.0 24V, 3.0 V6		<b>F8-6131</b>		d=24
Engine Mounting	1.6, 1.8, 1.8 16V, 2.0, 2.0 16V, 2.0 16V HPi, 2.0 HDi 110, 2.0 Turbo, 2.1 TD 12V, 2.2		<b>F8-6236</b>		H1=53; H2=40; d=10; D=70
Top Strut Mounting	1.6, 1.8, 1.8 16V, 1.9 D, 1.9 TD, 2.0 16V, 2.0 16V HPi, 2.0 HDi 110, 2.0 HDi 90, 2.0 Turbo, 2.1 TD 12V, 2.2, 2.2 HDi, 3.0 24V, 3.0 V6		<b>F8-6386</b>		
Anti-Friction Bearing	1.6, 1.8, 1.8 16V, 1.9 D, 1.9 TD, 2.0, 2.0 16V, 2.0 16V HPi, 2.0 HDi 110, 2.0 HDi 90, 2.0 Turbo, 2.1 TD 12V, 2.2, 2.2 HDi, 3.0 24V, 3.0 V6		<b>F8-6479</b>		
Engine Mounting	1.6, 1.8, 1.9 TD	ch.O7967→	<b>F8-6486</b>		
Engine Mounting	1.8 16V, 2.0 16V	ch.O7967→;	<b>F8-6486</b>		
Engine Mounting	1.8 16V, 2.0 16V HPi	ch.O07967→	<b>F8-6486</b>		
Engine Mounting	1.9 D, 2.2		<b>F8-6486</b>		
Engine Mounting	2.0 16V		<b>F8-6486</b>		
Engine Mounting	2.0 16V		<b>F8-6507</b>		
Engine Mounting	2.0, 2.0 HDi 110, 2.0 Turbo, 2.1 TD 12V, 2.2, 2.2 HDi, 3.0 V6		<b>F8-6507</b>		

<b>F8-5660</b>	<b>F8-5669</b>	<b>F8-5807</b>	<b>F8-5828</b>	<b>F8-5829</b>	<b>F8-5830</b>	<b>F8-5935</b>
Ref.Nr.: 0515R9	Ref.Nr.: 3640.35	Ref.Nr.: 515259	Ref.Nr.: 513178	Ref.Nr.: 513179	Ref.Nr.: 5131.80	Ref.Nr.: 5033.40
<b>F8-6026</b>	<b>F8-6130</b>	<b>F8-6131</b>	<b>F8-6236</b>	<b>F8-6386</b>	<b>F8-6479</b>	<b>F8-6486</b>
Ref.Nr.: 5035.32	Ref.Nr.: 5094.74	Ref.Nr.: 509475	Ref.Nr.: 1809.21	Ref.Nr.: 516120	Ref.Nr.: 5035.32	Ref.Nr.: 1844.77
<b>F8-6507</b>	<b>F8-6508</b>					
Ref.Nr.: 1827.16	Ref.Nr.: 1844.82					

**Article Description****Article Nr.****Fitting Position**

<b>406 (8B)</b>			<b>11/1995 → 06/2004</b>		
Engine Mounting	2.0	Orga.07967→	<b>F8-6508</b>	⊕	
Engine Mounting	2.0 HDi 110, 2.0 HDi 90, 2.0 Turbo, 2.1 TD 12V, 2.2 HDi		<b>F8-6508</b>	⊕	
Engine Mounting	1.8, 1.8 16V, 2.0 16V, 2.0 Turbo	Orga.→07966	<b>F8-6538</b>	⊕ ↑	
Holder, engine mounting	3.0 24V		<b>F8-7011</b>	⊕ ↓	d=10; L=53; D=69
Belt Pulley, crankshaft	1.8 16V, 2.0 16V	Number of Ribs: 6	<b>F8-7083</b>		Belt Pulley Ø [mm]=127; Mounting points diam.[mm]=30; W=38
Belt Pulley, crankshaft	1.8	06/1999 →; Number of Ribs: 6	<b>F8-7084</b>		Belt Pulley Ø [mm]=127; Mounting points diam.[mm]=30; W=45
Belt Pulley, crankshaft	1.8 16V	Number of Ribs: 6	<b>F8-7084</b>		Belt Pulley Ø [mm]=127; Mounting points diam.[mm]=30; W=45
Top Strut Mounting	1.6, 1.8, 1.8 16V, 1.9 D, 1.9 TD, 2.0 16V, 2.0 16V HPI, 2.0 HDi 110, 2.0 HDi 90, 2.0 Turbo, 2.1 TD 12V, 2.2, 2.2 HDi, 3.0 24V, 3.0 V6		<b>F8-7167</b>	⊕ ⊕	
Belt Pulley, crankshaft	3.0 24V, 3.0 V6		<b>F8-7874</b>		
Engine Mounting	2.0 HDi 110, 2.2 HDi		<b>F8-8167</b>	⊕	
Engine Mounting	2.0 HDi 110, 2.0 HDi 90, 2.2 HDi		<b>F8-8184</b>	⊕	
Bellow, steering	1.6, 1.8, 1.8 16V, 1.9 D, 1.9 TD, 2.0, 2.0 16V, 2.0 16V HPI, 2.0 HDi 110, 2.0 HDi 90, 2.0 Turbo, 2.1 TD 12V, 2.2, 2.2 HDi, 3.0 24V, 3.0 V6	with clamps	<b>LM-10072S</b>		d1=44; d2=44; L [mm]=120
<b>406 Estate (8E/F)</b>			<b>10/1996 → 10/2004</b>		
Dust Cover Kit, shock absorber	1.8 16V, 1.9 TD, 2.0 16V HPI, 2.0 HDi 110, 2.0 HDi 90, 2.0 Turbo, 2.1 TD 12V, 2.2, 2.2 HDi, 3.0 24V, 3.0 V6		<b>AK-735064</b>	⊕ ⊕	
Dust Cover Kit, shock absorber	1.8, 1.9 D	ch.07812→	<b>AK-735064</b>	⊕ ⊕	
Dust Cover Kit, shock absorber	2.0 16V, 2.0 HDi 110	ch.08547→	<b>AK-735064</b>	⊕ ⊕	
Dust Cover Kit, shock absorber	1.8, 1.9 D	ch.→07811	<b>AK-735096</b>		
Dust Cover Kit, shock absorber	1.9 TD, 2.0 HDi 90, 2.0 Turbo, 2.1 TD 12V, 2.2, 2.2 HDi, 3.0 24V, 3.0 V6		<b>AK-735096</b>		
Dust Cover Kit, shock absorber	2.0 16V, 2.0 HDi 110	ch.→08546	<b>AK-735096</b>		
Alternator Freewheel Clutch	2.0 HDi 110, 2.0 HDi 90, 2.2 HDi		<b>F5-1020</b>		
Alternator Freewheel Clutch	2.0 HDi 110, 2.0 HDi 90, 2.2 HDi		<b>F5-1046</b>		
Alternator Freewheel Clutch	2.2 HDi		<b>F5-1048</b>		
Engine Mounting	1.8		<b>F8-5026</b>		d=10; D=70; Thick. [mm]=40, 53
Control Arm-/Trailing Arm Bush	1.8, 1.8 16V, 1.9 D, 1.9 TD, 2.0 16V, 2.0 16V HPI, 2.0 HDi 110, 2.0 HDi 90, 2.0 Turbo, 2.1 TD 12V, 2.2, 2.2 HDi, 3.0 24V, 3.0 V6		<b>F8-5066</b>	⊕ ⊕ ↓	H1=38; H2=32; d=14; D=37

<b>AK-735064</b>	<b>AK-735096</b>	<b>F5-1020</b>	<b>F5-1046</b>	<b>F5-1048</b>	<b>F8-5026</b>	<b>F8-5066</b>
Ref.Nr.: 503340	Ref.Nr.:	Ref.Nr.: 31771-68D01	Ref.Nr.: 30667687	Ref.Nr.: 77363468	Ref.Nr.: 9606121080	Ref.Nr.: 3523.60
<b>F8-5099</b>	<b>F8-6508</b>	<b>F8-6538</b>	<b>F8-7011</b>	<b>F8-7083</b>	<b>F8-7084</b>	<b>F8-7167</b>
Ref.Nr.: 3523.61	Ref.Nr.: 1844.82	Ref.Nr.: 1839.46	Ref.Nr.: 1809.28	Ref.Nr.: 0515.K6	Ref.Nr.: 0515.H6	Ref.Nr.: 5038.66
<b>F8-7874</b>	<b>F8-8167</b>	<b>F8-8184</b>	<b>LM-10072S</b>			
Ref.Nr.: 0515.S2	Ref.Nr.: 9631575180	Ref.Nr.: 1806.33	Ref.Nr.: 4066.30			

Article Description

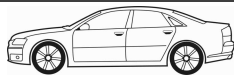

Article Nr.

Fitting Position



406 Estate (8E/F)		10/1996 → 10/2004			
Control Arm-/Trailing Arm Bush	1.8, 1.8 16V, 1.9 D, 1.9 TD, 2.0 16V, 2.0 16V HPI, 2.0 HDi 110, 2.0 HDi 90, 2.0 Turbo, 2.1 TD 12V, 2.2, 2.2 HDi, 3.0 24V, 3.0 V6		F8-5099		d=20; L=114; D=55; M12 x 1,50 RHT
Engine Mounting	1.8 16V, 2.0 16V	Orga. → 7966;	F8-5359		
Engine Mounting	1.8, 1.9 D, 1.9 TD, 2.0 Turbo	Orga. → 7966	F8-5359		
Engine Mounting	1.8, 1.8 16V, 2.2 HDi, 3.0 24V, 3.0 V6		F8-5375		H=34; d=12; D=30
Engine Mounting	1.9 D, 1.9 TD, 2.1 TD 12V	ch. → 007967	F8-5375		H=34; d=12; D=30
Engine Mounting	1.8, 1.8 16V, 2.0 16V		F8-5556		
Engine Mounting	1.8 16V, 1.9 D, 1.9 TD, 2.0 16V, 2.0 HDi 90		F8-5569		
Control Arm-/Trailing Arm Bush	1.8 16V, 2.0 16V, 2.0 16V HPI, 2.0 HDi 110, 2.0 HDi 90, 2.2, 2.2 HDi, 3.0 V6		F8-5630		H=57; d=14; D=45
Control Arm-/Trailing Arm Bush	1.8, 1.8 16V, 1.9 D, 1.9 TD, 2.0, 2.0 16V, 2.0 Turbo, 2.1 TD 12V, 3.0 24V	11/1997 →; Orga. 07665 →	F8-5630		H=57; d=14; D=45
Belt Pulley, crankshaft	2.0 HDi 110	Orga. → 09337;	F8-5636		d=30
Belt Pulley, crankshaft	2.0 HDi 110	Orga. → 09365;	F8-5636		d=30
Belt Pulley, crankshaft	2.2 HDi		F8-5636		d=30
Belt Pulley, crankshaft	1.9 D, 1.9 TD	Number of Ribs: 6	F8-5643		Belt Pulley Ø [mm]=156; W=44
Belt Pulley, crankshaft	2.1 TD 12V		F8-5647		
Belt Pulley, crankshaft	2.0 HDi 110	ch. O09338, O09366 →;	F8-5660		
Belt Pulley, crankshaft	2.0 HDi 110	Orga. 09338 →;	F8-5660		
Belt Pulley, crankshaft	2.0 HDi 110	Orga. 09366 →;	F8-5660		
Belt Pulley, crankshaft	2.0 HDi 90	12/2002 →;	F8-5660		
Control Arm-/Trailing Arm Bush	1.8, 1.8 16V, 1.9 D, 1.9 TD, 2.0, 2.0 16V, 2.0 Turbo, 2.1 TD 12V, 3.0 24V	Orga. → 07664	F8-5669		H=56.8; d=14; D=45
Mounting, axle beam	1.8, 1.8 16V, 1.9 D, 1.9 TD, 2.0 16V, 2.0 16V HPI, 2.0 HDi 110, 2.0 HDi 90, 2.0 Turbo, 2.1 TD 12V, 2.2, 2.2 HDi, 3.0 24V, 3.0 V6		F8-5807		d=14; D=40
Control Arm-/Trailing Arm Bush	1.8, 1.8 16V, 1.9 D, 1.9 TD, 2.0 16V, 2.0 16V HPI, 2.0 HDi 110, 2.0 HDi 90, 2.0 Turbo, 2.1 TD 12V, 2.2, 2.2 HDi, 3.0 24V, 3.0 V6		F8-5828		d=12; D=41; Total Br. Drum Height [mm]=41
Control Arm-/Trailing Arm Bush	1.8, 1.8 16V, 1.9 D, 1.9 TD, 2.0 16V, 2.0 16V HPI, 2.0 HDi 110, 2.0 HDi 90, 2.0 Turbo, 2.1 TD 12V, 2.2, 2.2 HDi, 3.0 24V, 3.0 V6		F8-5829		H1=65; H2=46; d=14; D=56
Control Arm-/Trailing Arm Bush	1.8, 1.8 16V, 1.9 D, 1.9 TD, 2.0 16V, 2.0 16V HPI, 2.0 HDi 110, 2.0 HDi 90, 2.0 Turbo, 2.1 TD 12V, 2.2, 2.2 HDi, 3.0 24V, 3.0 V6		F8-5830		H1=60; H2=48; d=12; D=32
Rubber Buffer, suspension	All Models		F8-5935		H=109
Top Strut Mounting	1.8, 1.8 16V, 1.9 D, 1.9 TD, 2.0, 2.0 16V, 2.0 16V HPI, 2.0 HDi 110, 2.0 HDi 90, 2.0 Turbo, 2.1 TD 12V, 2.2, 2.2 HDi, 3.0 24V, 3.0 V6		F8-6026		

<b>F8-5099</b>	<b>F8-5359</b>	<b>F8-5375</b>	<b>F8-5556</b>	<b>F8-5569</b>	<b>F8-5630</b>	<b>F8-5636</b>
Ref.Nr.: 3523.61	Ref.Nr.: 182723	Ref.Nr.: 180906	Ref.Nr.: 1843.95	Ref.Nr.: 9604338880	Ref.Nr.: 3640.41	Ref.Nr.: 0515P2
<b>F8-5643</b>	<b>F8-5647</b>	<b>F8-5660</b>	<b>F8-5669</b>	<b>F8-5807</b>	<b>F8-5828</b>	<b>F8-5829</b>
Ref.Nr.: 96089 38980	Ref.Nr.: 0515J9	Ref.Nr.: 0515R9	Ref.Nr.: 3640.35	Ref.Nr.: 515259	Ref.Nr.: 513178	Ref.Nr.: 513179
<b>F8-5830</b>	<b>F8-5935</b>	<b>F8-6026</b>	<b>F8-6130</b>			
Ref.Nr.: 5131.80	Ref.Nr.: 5033.40	Ref.Nr.: 5035.32	Ref.Nr.: 5094.74			

**Article Description****Article Nr.****Fitting Position**

<b>406 Estate (8E/F)</b>		<b>10/1996 → 10/2004</b>	
Stabiliser Mounting	1.8, 1.8 16V, 1.9 D, 1.9 TD, 2.0, 2.0 16V, 2.0 16V HPI, 2.0 HDI 110, 2.0 HDI 90, 2.0 Turbo, 2.1 TD 12V, 2.2, 2.2 HDI, 3.0 24V, 3.0 V6	F8-6130	⊕ ⊕ ⊕ d=23
Stabiliser Mounting	All Models	F8-6131	⊕ ⊕ ⊕ d=24
Engine Mounting	1.8, 1.8 16V, 2.0, 2.0 16V, 2.0 16V HPI, 2.0 HDI 110, 2.0 Turbo, 2.1 TD 12V, 2.2	F8-6236	⊕ H1=53; H2=40; d=10; D=70
Top Strut Mounting	1.8, 1.8 16V, 1.9 D, 1.9 TD, 2.0 16V, 2.0 16V HPI, 2.0 HDI 110, 2.0 HDI 90, 2.0 Turbo, 2.1 TD 12V, 2.2, 2.2 HDI, 3.0 24V, 3.0 V6	F8-6386	
Anti-Friction Bearing	All Models	F8-6479	⊕ ⊕ ⊕
Engine Mounting	1.8 16V, 2.0 16V	ch.O7967→;	F8-6486 ⊕
Engine Mounting	1.8 16V, 2.0 16V HPI	ch.O07967→	F8-6486 ⊕
Engine Mounting	1.8, 1.9 D, 1.9 TD	ch.O7967→	F8-6486 ⊕
Engine Mounting	2.0 16V		F8-6486 ⊕
Engine Mounting	2.2		F8-6486 ⊕
Engine Mounting	2.0 16V		F8-6507 ⊕
Engine Mounting	2.0, 2.0 HDi 110, 2.0 Turbo, 2.1 TD 12V, 2.2, 2.2 HDI, 3.0 V6		F8-6507 ⊕
Engine Mounting	2.0	Orga.07967→	F8-6508 ⊕
Engine Mounting	2.0 HDI 110, 2.0 HDI 90, 2.0 Turbo, 2.1 TD 12V, 2.2 HDI		F8-6508 ⊕
Engine Mounting	1.8, 1.8 16V, 2.0 16V, 2.0 Turbo	Orga.→07966	F8-6538 ⊕ ↑
Holder, engine mounting	3.0 24V		F8-7011 ⊕ ↓ d=10; L=53; D=69
Belt Pulley, crankshaft	1.8 16V, 2.0 16V	Number of Ribs: 6	F8-7083 Belt Pulley Ø [mm]=127; Mounting points diam.[mm]=30; W=38
Top Strut Mounting	1.8, 1.8 16V, 1.9 D, 1.9 TD, 2.0 16V, 2.0 16V HPI, 2.0 HDI 110, 2.0 HDI 90, 2.0 Turbo, 2.1 TD 12V, 2.2, 2.2 HDI, 3.0 24V, 3.0 V6		F8-7167  ⊕ ⊕ ⊕
Belt Pulley, crankshaft	3.0 24V, 3.0 V6		F8-7874
Engine Mounting	2.0 HDi 110, 2.0 HDI 90, 2.2 HDI		F8-8167 ⊕
Engine Mounting	2.0 HDI 110, 2.0 HDI 90, 2.2 HDI		F8-8184 ⊕
Bellow, steering	All Models	with clamps	LM-10072S  d1=44; d2=44; L [mm]=120
<b>406 Coupe (8C)</b>		<b>03/1997 → 12/2004</b>	
Dust Cover Kit, shock absorber	2.0 16V, 2.2, 2.2 HDI, 3.0 V6, 3.0 V6 24V	AK-735064	⊕ ⊕ ⊕
Alternator Freewheel Clutch	2.2 HDI	F5-1020	
Alternator Freewheel Clutch	2.2 HDI	F5-1046	
Alternator Freewheel Clutch	2.2 HDI	F5-1048	
Control Arm-Trailing Arm Bush	2.0 16V, 2.2, 2.2 HDI, 3.0 V6, 3.0 V6 24V	F8-5066	⊕ ⊕ ⊕ ↓ H1=38; H2=32; d=14; D=37

<b>AK-735064</b>	<b>F5-1020</b>	<b>F5-1046</b>	<b>F5-1048</b>	<b>F8-5066</b>	<b>F8-5099</b>	<b>F8-6130</b>
Ref.Nr.: 503340	Ref.Nr.: 31771-68D01	Ref.Nr.: 30667687	Ref.Nr.: 77363468	Ref.Nr.: 3523.60	Ref.Nr.: 3523.61	Ref.Nr.: 5094.74
<b>F8-6131</b>	<b>F8-6236</b>	<b>F8-6386</b>	<b>F8-6479</b>	<b>F8-6486</b>	<b>F8-6507</b>	<b>F8-6508</b>
Ref.Nr.: 509475	Ref.Nr.: 1809.21	Ref.Nr.: 516120	Ref.Nr.: 5035.32	Ref.Nr.: 1844.77	Ref.Nr.: 1827.16	Ref.Nr.: 1844.82
<b>F8-6538</b>	<b>F8-7011</b>	<b>F8-7083</b>	<b>F8-7167</b>	<b>F8-7874</b>	<b>F8-8167</b>	<b>F8-8184</b>
Ref.Nr.: 1839.46	Ref.Nr.: 1809.28	Ref.Nr.: 0515.K6	Ref.Nr.: 5038.66	Ref.Nr.: 0515.S2	Ref.Nr.: 9631575180	Ref.Nr.: 1806.33

Article Description

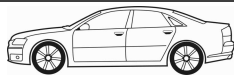

Article Nr.

Fitting Position



406 Coupé (8C)		03/1997 → 12/2004	
Control Arm-/Trailing Arm Bush	2.0 16V, 2.2, 2.2 HDI, 3.0 V6, 3.0 V6 24V		F8-5099
Engine Mounting	2.0 16V	05/1997 →;	F8-5359
Engine Mounting	2.2 HDI, 3.0 V6, 3.0 V6 24V		F8-5375
Engine Mounting	2.0 16V		F8-5556
Engine Mounting	2.0 16V		F8-5569
Control Arm-/Trailing Arm Bush	2.0 16V, 2.2, 2.2 HDI, 3.0 V6, 3.0 V6 24V		F8-5630
Mounting, axle beam	2.0 16V, 2.2, 2.2 HDI, 3.0 V6, 3.0 V6 24V		F8-5807
Control Arm-/Trailing Arm Bush	2.0 16V, 2.2, 2.2 HDI, 3.0 V6, 3.0 V6 24V		F8-5828
Control Arm-/Trailing Arm Bush	2.0 16V, 2.2, 2.2 HDI, 3.0 V6, 3.0 V6 24V		F8-5829
Control Arm-/Trailing Arm Bush	2.0 16V, 2.2, 2.2 HDI, 3.0 V6, 3.0 V6 24V		F8-5830
Rubber Buffer, suspension	2.0 16V, 2.2, 2.2 HDI, 3.0 V6, 3.0 V6 24V		F8-5935
Top Strut Mounting	2.0 16V, 3.0 V6, 3.0 V6 24V		F8-6026
Stabiliser Mounting	2.0 16V, 2.2, 2.2 HDI, 3.0 V6, 3.0 V6 24V		F8-6130
Stabiliser Mounting	2.0 16V, 2.2, 2.2 HDI, 3.0 V6, 3.0 V6 24V		F8-6131
Engine Mounting	2.0 16V, 2.2		F8-6236
Anti-Friction Bearing	2.0 16V, 2.2, 2.2 HDI, 3.0 V6, 3.0 V6 24V		F8-6479
Engine Mounting	2.0 16V	04/1999 →;	F8-6486
Engine Mounting	2.0 16V		F8-6486
Engine Mounting	2.0 16V, 2.2		F8-6486
Engine Mounting	2.0 16V		F8-6507
Engine Mounting	2.2, 2.2 HDI, 3.0 V6		F8-6507
Engine Mounting	2.0 16V	Orga. →07966	F8-6538
Holder, engine mounting	3.0 V6 24V		F8-7011
Belt Pulley, crankshaft	2.0 16V	Number of Ribs: 6	F8-7083
Top Strut Mounting	2.0 16V, 3.0 V6, 3.0 V6 24V		F8-7167
Belt Pulley, crankshaft	3.0 V6, 3.0 V6 24V		F8-7874
Engine Mounting	2.2 HDI		F8-8184
Bellow, steering	2.0 16V, 2.2, 2.2 HDI, 3.0 V6, 3.0 V6 24V	with clamps	LM-10072S
<b>407 (6D_)</b>		<b>05/2004 →</b>	
Alternator Freewheel Clutch	1.6 HDi 110, 2.0 HDi, 2.0 HDi 135		F5-1046
Alternator Freewheel Clutch	1.6 HDi 110, 2.0 HDi, 2.0 HDi 135		F5-1048

<b>F5-1046</b>	<b>F5-1048</b>	<b>F5-1109</b>	<b>F8-5099</b>	<b>F8-5359</b>	<b>F8-5375</b>	<b>F8-5556</b>
Ref.Nr.: 30667687	Ref.Nr.: 77363468	Ref.Nr.:	Ref.Nr.: 3523.61	Ref.Nr.: 182723	Ref.Nr.: 180906	Ref.Nr.: 1843.95
<b>F8-5569</b>	<b>F8-5630</b>	<b>F8-5807</b>	<b>F8-5828</b>	<b>F8-5829</b>	<b>F8-5830</b>	<b>F8-5935</b>
Ref.Nr.: 9604338880	Ref.Nr.: 3640.41	Ref.Nr.: 515259	Ref.Nr.: 513178	Ref.Nr.: 513179	Ref.Nr.: 5131.80	Ref.Nr.: 5033.40
<b>F8-6026</b>	<b>F8-6130</b>	<b>F8-6131</b>	<b>F8-6236</b>	<b>F8-6479</b>	<b>F8-6486</b>	<b>F8-6507</b>
Ref.Nr.: 5035.32	Ref.Nr.: 5094.74	Ref.Nr.: 509475	Ref.Nr.: 1809.21	Ref.Nr.: 5035.32	Ref.Nr.: 1844.77	Ref.Nr.: 1827.16

**Article Description****Article Nr.****Fitting Position**

<b>407 (6D_)</b>				<b>05/2004 →</b>	
Alternator Freewheel Clutch	2.7 HDi		<b>F5-1109</b>		
Engine Mounting	1.8, 1.8 16V, 2.0, 2.0 16V, 2.0 HDi 135		<b>F8-6236</b>		H1=53; H2=40; d=10; D=70
Mounting, support frame/engine carrier	1.6 HDi 110, 1.8, 1.8 16V, 2.0, 2.0 16V, 2.0 HDi, 2.0 HDi 135, 2.2, 2.2 16V, 2.2 HDi 170, 2.7 HDi, 3.0		<b>F8-6586</b>		
Belt Pulley, crankshaft	1.6 HDi 110	Number of Ribs: 6	<b>F8-7082</b>		Belt Pulley Ø [mm]=152; Mounting points diam.[mm]=30; W=34
Rubber Buffer, suspension	1.6 HDi 110, 1.8, 1.8 16V, 2.0, 2.0 16V, 2.0 Bioflex, 2.0 HDi 135, 2.2, 2.2 16V, 2.2 HDi 170	<b>ST</b>	<b>F8-7588</b>		H=85
Top Strut Mounting	1.6 HDi 110, 1.8, 1.8 16V, 2.0, 2.0 16V, 2.0 Bioflex, 2.0 HDi, 2.0 HDi 135, 2.2, 2.2 16V, 2.2 HDi, 2.2 HDi 170	⊙ 17	<b>F8-7605</b>		
Rubber Buffer, suspension	1.6 HDi 110, 1.8, 1.8 16V, 2.0, 2.0 16V, 2.0 Bioflex, 2.0 HDi, 2.0 HDi 135, 2.2, 2.2 16V, 2.2 HDi 170, 2.7 HDi, 3.0	<b>ST</b>	<b>F8-7673</b>		H=65
Belt Pulley, crankshaft	2.0 HDi 135		<b>F8-7861</b>		
Belt Pulley, crankshaft	3.0		<b>F8-7874</b>		
Engine Mounting	2.0 HDi 135		<b>F8-8149</b>		
Engine Mounting	1.6 HDi 110		<b>F8-8184</b>		
Engine Mounting	2.2, 2.2 16V, 2.2 HDi, 2.2 HDi 170, 3.0		<b>F8-8202</b>		
<b>407 Coupe (6C_)</b>				<b>10/2005 →</b>	
Alternator Freewheel Clutch	2.0 HDi		<b>F5-1046</b>		
Alternator Freewheel Clutch	2.0 HDi		<b>F5-1048</b>		
Alternator Freewheel Clutch	2.7 HDi		<b>F5-1109</b>		
Engine Mounting	2.0 HDi		<b>F8-6236</b>		H1=53; H2=40; d=10; D=70
Mounting, support frame/engine carrier	2.0 HDi, 2.2 16V, 2.7 HDi, 3.0 V6		<b>F8-6586</b>		
Rubber Buffer, suspension	2.0 HDi, 2.2 16V	<b>ST</b>	<b>F8-7588</b>		H=85
Top Strut Mounting	2.0 HDi, 2.2 16V, 3.0 HDi	⊙ 17	<b>F8-7605</b>		
Rubber Buffer, suspension	2.0 HDi, 2.2 16V, 2.7 HDi, 3.0 HDi, 3.0 V6	<b>ST</b>	<b>F8-7673</b>		H=65
Belt Pulley, crankshaft	3.0 V6		<b>F8-7874</b>		
Engine Mounting	2.0 HDi		<b>F8-8149</b>		
Engine Mounting	3.0 V6		<b>F8-8169</b>		
Engine Mounting	2.2 16V, 3.0 V6		<b>F8-8202</b>		
<b>407 SW (6E_)</b>				<b>05/2004 →</b>	
Alternator Freewheel Clutch	1.6 HDi 110, 2.0 HDi, 2.0 HDi 135		<b>F5-1046</b>		
Alternator Freewheel Clutch	1.6 HDi 110, 2.0 HDi, 2.0 HDi 135		<b>F5-1048</b>		
Alternator Freewheel Clutch	2.7 HDi		<b>F5-1109</b>		

<b>F5-1046</b>	<b>F5-1048</b>	<b>F5-1109</b>	<b>F8-6236</b>	<b>F8-6586</b>	<b>F8-7082</b>	<b>F8-7588</b>
Ref.Nr.: 30667687	Ref.Nr.: 77363468	Ref.Nr.:	Ref.Nr.: 1809.21	Ref.Nr.: 3504.30	Ref.Nr.: 0515.R0	Ref.Nr.: 5033.86
<b>F8-7605</b>	<b>F8-7673</b>	<b>F8-7861</b>	<b>F8-7874</b>	<b>F8-8149</b>	<b>F8-8169</b>	<b>F8-8184</b>
Ref.Nr.: 5038A6	Ref.Nr.: 9652181980	Ref.Nr.: 0515 Q8	Ref.Nr.: 0515.S2	Ref.Nr.: 1844.93	Ref.Nr.: 180669	Ref.Nr.: 1806.33
<b>F8-8202</b>						
Ref.Nr.: 1844.C0						

**Article Description**

**Article Nr.**
**Fitting Position**

<b>407 SW (6E_)</b>		<b>05/2004 →</b>				
Engine Mounting	1.8, 1.8 16V, 2.0, 2.0 16V, 2.0 HDi 135	<b>F8-6236</b>			H1=53; H2=40; d=10; D=70	
Mounting, support frame/engine carrier	1.6 HDi 110, 1.8, 1.8 16V, 2.0, 2.0 16V, 2.0 HDi, 2.0 HDi 135, 2.2, 2.2 16V, 2.2 HDi 170, 2.7 HDi, 3.0	<b>F8-6586</b>				
Belt Pulley, crankshaft	1.6 HDi 110	Number of Ribs: 6	<b>F8-7082</b>		Belt Pulley Ø [mm]=152; Mounting points diam.[mm]=30; W=34	
Rubber Buffer, suspension	1.6 HDi 110, 1.8, 1.8 16V, 2.0, 2.0 16V, 2.0 Bioflex, 2.0 HDi 135, 2.2, 2.2 16V, 2.2 HDi 170	<b>ST</b>	<b>F8-7588</b>			H=85
Top Strut Mounting	1.6 HDi 110, 1.8, 1.8 16V, 2.0, 2.0 16V, 2.0 Bioflex, 2.0 HDi, 2.0 HDi 135, 2.2, 2.2 16V, 2.2 HDi, 2.2 HDi 170	⊙ 17	<b>F8-7605</b>			
Rubber Buffer, suspension	1.6 HDi 110, 1.8, 1.8 16V, 2.0, 2.0 16V, 2.0 Bioflex, 2.0 HDi, 2.0 HDi 135, 2.2, 2.2 16V, 2.2 HDi 170, 2.7 HDi, 3.0	<b>ST</b>	<b>F8-7673</b>			H=65
Belt Pulley, crankshaft	2.0 HDi 135		<b>F8-7861</b>			
Belt Pulley, crankshaft	3.0		<b>F8-7874</b>			
Engine Mounting	2.0 HDi 135		<b>F8-8149</b>			
Engine Mounting	1.8, 1.8 16V, 2.0, 2.0 16V, 2.0 Bioflex, 3.0		<b>F8-8169</b>			
Engine Mounting	1.6 HDi 110		<b>F8-8184</b>			
Engine Mounting	2.2, 2.2 16V, 2.2 HDi, 2.2 HDi 170, 3.0		<b>F8-8202</b>			
<b>504 (A, M)</b>		<b>07/1968 → 07/1986</b>				
Anti-Friction Bearing	1.8, 1.8 Injection, 1.9 D, 2.0, 2.0 TI, 2.1 D, 2.3 D		<b>F8-3012</b>			H=20; d=66; D=100
Control Arm-/Trailing Arm Bush	1.8, 1.8 Injection, 1.9 D, 2.0, 2.0 TI, 2.1 D, 2.3 D		<b>F8-6817</b>			H=42; d=16; D1=38; D2=50
Engine Mounting	1.9 D, 2.1 D, 2.3 D		<b>F8-6905</b>			
<b>504 Break (D, F)</b>		<b>04/1971 → 07/1986</b>				
Anti-Friction Bearing	All Models		<b>F8-3012</b>			H=20; d=66; D=100
Engine Mounting	2.1 D, 2.3 D		<b>F8-6905</b>			
<b>504 Convertible</b>		<b>10/1974 → 08/1984</b>				
Anti-Friction Bearing	All Models		<b>F8-3012</b>			H=20; d=66; D=100
<b>504 Coupe</b>		<b>10/1974 → 08/1984</b>				
Anti-Friction Bearing	All Models		<b>F8-3012</b>			H=20; d=66; D=100
<b>504 Pickup (E)</b>		<b>01/1980 → 12/1989</b>				
Anti-Friction Bearing	1.6, 1.9 D, 2.3 D		<b>F8-3012</b>			H=20; d=66; D=100
Engine Mounting	1.9 D, 2.3 D		<b>F8-6905</b>			

<b>F8-3012</b>	<b>F8-6236</b>	<b>F8-6586</b>	<b>F8-6817</b>	<b>F8-6905</b>	<b>F8-7082</b>	<b>F8-7588</b>
Ref.Nr.: 503527	Ref.Nr.: 1809.21	Ref.Nr.: 3504.30	Ref.Nr.: 3561.09	Ref.Nr.: 1807.28	Ref.Nr.: 0515.R0	Ref.Nr.: 5033.86
<b>F8-7605</b>	<b>F8-7673</b>	<b>F8-7861</b>	<b>F8-7874</b>	<b>F8-8149</b>	<b>F8-8169</b>	<b>F8-8184</b>
Ref.Nr.: 5038A6	Ref.Nr.: 9652181980	Ref.Nr.: 0515.Q8	Ref.Nr.: 0515.S2	Ref.Nr.: 1844.93	Ref.Nr.: 180669	Ref.Nr.: 1806.33
<b>F8-8202</b>						
Ref.Nr.: 1844.C0						



**Article Description****Article Nr.****Fitting Position**

<b>505 (551A)</b>			<b>08/1979 → 09/1995</b>		
Anti-Friction Bearing	1.8, 2.0, 2.0 TI, STI, 2.2, 2.2 GTI, 2.2 Turbo Injection, 2.3 Turbo Diesel, 2.5 Diesel, 2.5 Turbo Diesel, 2.8 GTI V6		<b>F8-3012</b>		H=20; d=66; D=100
Control Arm-/Trailing Arm Bush	1.8, 2.0, 2.0 TI, STI, 2.2, 2.2 GTI, 2.2 Turbo Injection, 2.3 Turbo Diesel, 2.5 Diesel, 2.5 Turbo Diesel, 2.8 GTI V6		<b>F8-6817</b>		H=42; d=16; D1=38; D2=50
Engine Mounting	2.3 Turbo Diesel, 2.5 Diesel, 2.5 Turbo Diesel		<b>F8-6905</b>		
Bellow, steering	1.8, 2.0, 2.0 TI, STI, 2.2, 2.2 GTI, 2.2 Turbo Injection, 2.3 Turbo Diesel, 2.5 Diesel, 2.5 Turbo Diesel, 2.8 GTI V6	with clamps;	<b>LM-10049S</b>		d1=39; d2=39; L [mm]=130
<b>505 Break (551D)</b>			<b>04/1982 → 12/1993</b>		
Anti-Friction Bearing	2.0, 2.2, 2.2 GTI, 2.3 Diesel, 2.5 Diesel, 2.5 Turbo Diesel		<b>F8-3012</b>		H=20; d=66; D=100
Engine Mounting	2.3 Diesel, 2.5 Diesel, 2.5 Turbo Diesel		<b>F8-6905</b>		
Control Arm-/Trailing Arm Bush	2.0, 2.2, 2.2 GTI, 2.3 Diesel, 2.5 Diesel, 2.5 Turbo Diesel		<b>F8-7994</b>		H=40; d=16
Bellow, steering	2.0, 2.2, 2.2 GTI, 2.3 Diesel, 2.5 Diesel, 2.5 Turbo Diesel	with clamps;	<b>LM-10049S</b>		d1=39; d2=39; L [mm]=130
<b>508</b>			<b>11/2010 →</b>		
Alternator Freewheel Clutch	1.6, 1.6 THP, 1.6 VTi		<b>F5-1113</b>		
Alternator Freewheel Clutch	1.6, 1.6 THP, 1.6 VTi		<b>F5-1132</b>		
<b>508 SW</b>			<b>11/2010 →</b>		
Alternator Freewheel Clutch	1.6 THP, 1.6 VTi		<b>F5-1113</b>		
Alternator Freewheel Clutch	1.6 THP, 1.6 VTi		<b>F5-1132</b>		
<b>604 (561A_)</b>			<b>08/1977 → 07/1987</b>		
Control Arm-/Trailing Arm Bush	2.3 TD, 2.5 TD, 2.7 SL, 2.7 TI, STI, 2.8 GTI		<b>F8-6816</b>		
<b>605 (6B)</b>			<b>06/1989 → 09/1999</b>		
Dust Cover Kit, shock absorber	2.0, 2.0 16V, 2.0 Turbo, 2.1 D, 2.1 TD 12V, 2.1 Turbo Diesel, 2.5 Turbo Diesel, 3.0, 3.0 SV 24, 3.0 V6		<b>AK-735064</b>		
Dust Cover Kit, shock absorber	2.0, 2.0 16V, 2.0 Turbo, 2.1 D, 2.1 TD 12V, 2.1 Turbo Diesel, 2.5 Turbo Diesel, 3.0, 3.0 SV 24, 3.0 V6		<b>AK-735096</b>		
Control Arm-/Trailing Arm Bush	2.0, 2.0 16V, 2.0 Turbo, 2.1 D, 2.1 TD 12V, 2.1 Turbo Diesel, 2.5 Turbo Diesel, 3.0, 3.0 SV 24, 3.0 V6		<b>F8-5150</b>		H=28; d=14; D=40
Control Arm-/Trailing Arm Bush	2.0, 2.0 16V, 2.0 Turbo, 2.1 TD 12V, 2.5 Turbo Diesel, 3.0, 3.0 SV 24, 3.0 V6	06/1989 →; Number of Cylinders: 6	<b>F8-5293</b>		
Control Arm-/Trailing Arm Bush	2.0, 2.1 D, 2.1 Turbo Diesel	Number of Cylinders: 6	<b>F8-5293</b>		
Engine Mounting	2.0, 2.0 16V, 2.0 Turbo, 2.1 D		<b>F8-5569</b>		
Top Strut Mounting	All Models		<b>F8-5615</b>		
Belt Pulley, crankshaft	2.1 D	06/1995 →;	<b>F8-5647</b>		

<b>AK-735064</b>	<b>AK-735096</b>	<b>F5-1113</b>	<b>F5-1132</b>	<b>F8-3012</b>	<b>F8-5150</b>	<b>F8-5293</b>
Ref.Nr.: 503340	Ref.Nr.:	Ref.Nr.: 12317576515	Ref.Nr.:	Ref.Nr.: 503527	Ref.Nr.: 3523.43	Ref.Nr.: 3523.45
<b>F8-5569</b>	<b>F8-5615</b>	<b>F8-5647</b>	<b>F8-6816</b>	<b>F8-6817</b>	<b>F8-6905</b>	<b>F8-7994</b>
Ref.Nr.: 9604338880	Ref.Nr.: 503135	Ref.Nr.: 0515J9	Ref.Nr.: 3523.16	Ref.Nr.: 3561.09	Ref.Nr.: 1807.28	Ref.Nr.: 3523.14
<b>LM-10049S</b>						
Ref.Nr.: 4066.17						

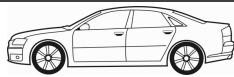
**Article Description**

**Article Nr.**
**Fitting Position**

<b>605 (6B)</b>			<b>06/1989 → 09/1999</b>		
Belt Pulley, crankshaft	2.1 TD 12V		<b>F8-5647</b>		
Belt Pulley, crankshaft	2.1 Turbo Diesel	ch.→O07237; 06/1995 →;	<b>F8-5647</b>		
Control Arm-/Trailing Arm Bush	2.0, 2.0 16V, 2.0 Turbo, 2.1 D, 2.1 TD 12V, 2.1 Turbo Diesel, 2.5 Turbo Diesel, 3.0, 3.0 SV 24, 3.0 V6		<b>F8-5806</b>		H=25; d=12; D=32
Control Arm-/Trailing Arm Bush	2.0, 2.0 16V, 2.0 Turbo, 2.1 D, 2.1 TD 12V, 2.1 Turbo Diesel, 2.5 Turbo Diesel, 3.0, 3.0 SV 24, 3.0 V6		<b>F8-5835</b>		H=45; d=12; D=36
Control Arm-/Trailing Arm Bush	2.0, 2.0 16V, 2.0 Turbo, 2.1 D, 2.1 TD 12V, 2.1 Turbo Diesel, 2.5 Turbo Diesel, 3.0, 3.0 SV 24, 3.0 V6		<b>F8-5836</b>		H=30; d=14; D=34
Control Arm-/Trailing Arm Bush	2.0, 2.0 16V, 2.0 Turbo, 2.1 D, 2.1 TD 12V, 2.1 Turbo Diesel, 2.5 Turbo Diesel, 3.0, 3.0 SV 24, 3.0 V6		<b>F8-5837</b>		H=60; d=12; D=32
Control Arm-/Trailing Arm Bush	2.0, 2.0 16V, 2.0 Turbo, 2.1 D, 2.1 TD 12V, 2.1 Turbo Diesel, 2.5 Turbo Diesel, 3.0, 3.0 SV 24, 3.0 V6		<b>F8-5872</b>		H1=60; H2=40; d=12; D=40
Rubber Buffer, suspension	2.0, 2.0 16V, 2.0 Turbo, 2.1 D, 2.1 TD 12V, 2.1 Turbo Diesel, 2.5 Turbo Diesel, 3.0, 3.0 SV 24, 3.0 V6		<b>F8-5935</b>		H=109
Mounting, axle beam	2.0, 2.0 16V, 2.0 Turbo, 2.1 D, 2.1 TD 12V, 2.1 Turbo Diesel, 2.5 Turbo Diesel, 3.0, 3.0 SV 24, 3.0 V6		<b>F8-6023</b>		
Engine Mounting	2.0, 2.0 16V, 2.0 Turbo		<b>F8-6236</b>		H1=53; H2=40; d=10; D=70
Top Strut Mounting	2.0, 2.0 16V, 2.0 Turbo, 2.1 D, 2.1 TD 12V, 2.1 Turbo Diesel, 2.5 Turbo Diesel, 3.0, 3.0 SV 24, 3.0 V6		<b>F8-6305</b>		
Belt Pulley, crankshaft	2.5 Turbo Diesel		<b>F8-6395</b>		
Anti-Friction Bearing	All Models		<b>F8-6479</b>		
Engine Mounting	2.0	01/1990 →;	<b>F8-6507</b>		
Engine Mounting	2.0, 2.0 16V, 2.0 Turbo, 3.0 V6		<b>F8-6507</b>		
Engine Mounting	2.1 D, 2.1 Turbo Diesel	01/1994 →	<b>F8-6507</b>		
Engine Mounting	2.1 TD 12V, 3.0, 3.0 SV 24		<b>F8-6507</b>		
Engine Mounting	2.0 Turbo	07/1992 →	<b>F8-6857</b>		
Engine Mounting	2.0, 2.0 16V, 2.0 Turbo		<b>F8-6857</b>		
Engine Mounting	2.1 D	08/1990 →	<b>F8-6857</b>		
Holder, engine mounting	3.0 V6		<b>F8-7011</b>		d=10; L=53; D=69
Belt Pulley, crankshaft	2.0 16V	Number of Ribs: 6	<b>F8-7083</b>		Belt Pulley Ø [mm]=127; Mounting points diam.[mm]=30; W=38
Belt Pulley, crankshaft	3.0 V6		<b>F8-7874</b>		
Bellow, steering	All Models	with clamps	<b>LM-10072S</b>		d1=44; d2=44; L [mm]=120
<b>607 (9D, 9U)</b>			<b>02/2000 → 07/2004</b>		
Alternator Freewheel Clutch	2.0 HDI, 2.2 HDI		<b>F5-1020</b>		
Alternator Freewheel Clutch	2.0 HDi, 2.2 HDI		<b>F5-1046</b>		
Alternator Freewheel Clutch	2.0 HDi, 2.2 HDI		<b>F5-1048</b>		
Alternator Freewheel Clutch	2.7 HDi 24V		<b>F5-1109</b>		

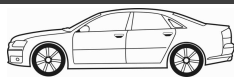
<b>F5-1020</b>	<b>F5-1046</b>	<b>F5-1048</b>	<b>F5-1109</b>	<b>F8-5150</b>	<b>F8-5647</b>	<b>F8-5806</b>
Ref.Nr.: 31771-68D01	Ref.Nr.: 30667687	Ref.Nr.: 77363468	Ref.Nr.:	Ref.Nr.: 3523.43	Ref.Nr.: 0515J9	Ref.Nr.: 333207
<b>F8-5835</b>	<b>F8-5836</b>	<b>F8-5837</b>	<b>F8-5872</b>	<b>F8-5935</b>	<b>F8-6023</b>	<b>F8-6236</b>
Ref.Nr.: 513154	Ref.Nr.: 513155	Ref.Nr.: 513156	Ref.Nr.: 5131.53	Ref.Nr.: 5033.40	Ref.Nr.: 5131.62	Ref.Nr.: 1809.21
<b>F8-6305</b>	<b>F8-6395</b>	<b>F8-6479</b>	<b>F8-6507</b>	<b>F8-6857</b>	<b>F8-7011</b>	<b>F8-7083</b>
Ref.Nr.: 503227	Ref.Nr.: 0515.H3	Ref.Nr.: 5035.32	Ref.Nr.: 1827.16	Ref.Nr.: 1827.22	Ref.Nr.: 1809.28	Ref.Nr.: 0515.K6

**Article Description****Article Nr.****Fitting Position**

<b>607 (9D, 9U)</b>			<b>02/2000 → 07/2004</b>		
Control Arm-/Trailing Arm Bush	2.2 16V, 2.2 HDI, 3.0 V6 24V		<b>F8-5150</b>		H=28; d=14; D=40
Belt Pulley, crankshaft	2.0 HDi	Orga.→09337; for vehicles with diesel soot filter	<b>F8-5636</b>		d=30
Belt Pulley, crankshaft	2.0 HDI, 2.2 HDI		<b>F8-5636</b>		d=30
Belt Pulley, crankshaft	2.0 HDI	ch.O09338→	<b>F8-5660</b>		
Belt Pulley, crankshaft	2.0 HDi	Orga.09338→	<b>F8-5660</b>		
Belt Pulley, crankshaft	2.2 HDI	Orga.10248→	<b>F8-5660</b>		
Control Arm-/Trailing Arm Bush	2.2 16V, 2.2 HDI		<b>F8-5806</b>		H=25; d=12; D=32
Control Arm-/Trailing Arm Bush	2.2 16V, 2.2 HDI		<b>F8-5835</b>		H=45; d=12; D=36
Control Arm-/Trailing Arm Bush	2.2 16V, 2.2 HDI		<b>F8-5836</b>		H=30; d=14; D=34
Control Arm-/Trailing Arm Bush	2.2 16V, 2.2 HDI		<b>F8-5837</b>		H=60; d=12; D=32
Control Arm-/Trailing Arm Bush	2.0, 2.0 HDi, 2.2 16V, 2.2 HDI, 2.7 HDi 24V, 3.0 V6 24V		<b>F8-5872</b>		H1=60; H2=40; d=12; D=40
Control Arm-/Trailing Arm Bush	2.2 HDi	DW12BTED4	<b>F8-5872</b>		H1=60; H2=40; d=12; D=40
Mounting, axle beam	2.2 16V, 2.2 HDI		<b>F8-6023</b>		
Engine Mounting	2.0, 2.0 HDI, 2.2 16V, 2.2 HDI		<b>F8-6236</b>		H1=53; H2=40; d=10; D=70
Top Strut Mounting	2.0, 2.0 HDI, 2.2 16V, 2.2 HDI, 3.0 V6 24V		<b>F8-6305</b>		
Anti-Friction Bearing	2.0, 2.0 HDI, 2.2 16V, 2.2 HDI, 3.0 V6 24V		<b>F8-6479</b>		
Engine Mounting	2.0 HDi		<b>F8-6500</b>		
Engine Mounting	2.2 16V		<b>F8-6500</b>		
Holder, engine mounting	3.0 V6 24V		<b>F8-7011</b>		d=10; L=53; D=69
Belt Pulley, crankshaft	3.0 V6 24V		<b>F8-7874</b>		
Engine Mounting	2.0 HDI		<b>F8-8149</b>		
Engine Mounting	2.0 HDi, 2.2 HDI		<b>F8-8167</b>		
Engine Mounting	2.0 HDI, 2.2 16V		<b>F8-8184</b>		
Engine Mounting	2.2 HDi, 3.0 V6 24V		<b>F8-8202</b>		
<b>806 (221)</b>			<b>06/1994 → 08/2002</b>		
Dust Cover Kit, shock absorber	All Models		<b>AK-735091</b>		
Alternator Freewheel Clutch	2.0 HDI, 2.0 HDI 16V		<b>F5-1020</b>		
Anti-Friction Bearing	All Models		<b>F8-3014</b>		H1=24; H2=46; d1=78; d2=84; D=128
Engine Mounting	1.8, 1.9 TD, 2.1 td 12V		<b>F8-5026</b>		d=10; D=70; Thick. [mm]=40, 53

<b>AK-735091</b>	<b>F5-1020</b>	<b>F8-3014</b>	<b>F8-5026</b>	<b>F8-5092</b>	<b>F8-5150</b>	<b>F8-5636</b>
Ref.Nr.: 503339	Ref.Nr.: 31771-68D01	Ref.Nr.: 503545	Ref.Nr.: 9606121080	Ref.Nr.: 1305782080	Ref.Nr.: 3523.43	Ref.Nr.: 0515P2
<b>F8-5660</b>	<b>F8-5806</b>	<b>F8-5835</b>	<b>F8-5836</b>	<b>F8-5837</b>	<b>F8-5872</b>	<b>F8-6023</b>
Ref.Nr.: 0515R9	Ref.Nr.: 333207	Ref.Nr.: 513154	Ref.Nr.: 513155	Ref.Nr.: 513156	Ref.Nr.: 5131.53	Ref.Nr.: 5131.62
<b>F8-6236</b>	<b>F8-6305</b>	<b>F8-6479</b>	<b>F8-6500</b>	<b>F8-7011</b>	<b>F8-7874</b>	<b>F8-8149</b>
Ref.Nr.: 1809.21	Ref.Nr.: 503227	Ref.Nr.: 5035.32	Ref.Nr.: 1844.36	Ref.Nr.: 1809.28	Ref.Nr.: 0515.S2	Ref.Nr.: 1844.93

Article Description



Article Nr.

Fitting Position



806 (221)		06/1994 → 08/2002	
Stabiliser Mounting	1.8, 1.9 TD, 2.0, 2.0 16V, 2.0 HDI, 2.0 Turbo, 2.1 td 12V	F8-5092	d=24
Engine Mounting	1.8, 2.0	F8-5569	
Top Strut Mounting	All Models	F8-5621	
Top Strut Mounting	All Models	F8-5622	
Belt Pulley, crankshaft	2.0 HDI, 2.0 HDI 16V	F8-5636	d=30
Belt Pulley, crankshaft	1.9 TD	F8-5643	Number of Ribs: 6 Belt Pulley Ø [mm]=156; W=44
Belt Pulley, crankshaft	2.1 td 12V	F8-5647	
Mounting, axle beam	1.8, 1.9 TD, 2.0, 2.0 16V, 2.0 HDI, 2.0 Turbo, 2.1 td 12V	F8-5871	H1=60; H2=48; d=12; D=46
Rubber Buffer, suspension	All Models	F8-5936	
Control Arm-/Trailing Arm Bush	All Models	F8-6153	
Control Arm-/Trailing Arm Bush	All Models	F8-6154	
Control Arm-/Trailing Arm Bush	All Models	F8-6155	
Engine Mounting	All Models	F8-6236	H1=53; H2=40; d=10; D=70
Top Strut Mounting	All Models	F8-6304	
Control Arm-/Trailing Arm Bush	1.8, 1.9 TD, 2.0, 2.0 16V, 2.0 HDI, 2.0 Turbo, 2.1 td 12V	F8-6439	H=50; d=22.85; Inner Thread 1=M12 x 1,25 RHT F; Inner Thread 2=M12 x 1,25 RHT F; L=82
Engine Mounting	1.9 TD, 2.0 16V, 2.0 HDI, 2.0 HDI 16V, 2.0 Turbo, 2.1 td 12V	F8-6507	
Engine Mounting	2.0 HDI	F8-6897	Orga. →08575
Top Strut Mounting	All Models	F8-7164	
Engine Mounting	2.0 HDI, 2.0 HDI 16V	F8-8149	
Engine Mounting	2.0 HDI, 2.0 HDI 16V	F8-8167	
Bellow, steering	All Models	LM-10022S	d1=13; d2=62; L [mm]=210
807 (E)		06/2002 → 05/2006	
Alternator Freewheel Clutch	2.0 HDi, 2.2 HDi	F5-1020	
Alternator Freewheel Clutch	2.0 HDi, 2.2 HDi	F5-1046	
Alternator Freewheel Clutch	2.0 HDi, 2.2 HDi	F5-1048	
Anti-Friction Bearing	2.0, 2.0 16V, 2.0 HDi, 2.2, 2.2 HDi, 3.0 V6	F8-3014	H1=24; H2=46; d1=78; d2=84; D=128
Engine Mounting	2.0 HDI	F8-5375	H=34; d=12; D=30
Engine Mounting	2.0, 2.0 16V, 2.0 HDI	F8-5569	
Top Strut Mounting	2.0, 2.0 16V, 2.0 HDI, 2.2, 2.2 HDi, 3.0 V6	F8-5621	

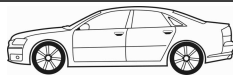

**Article Description****Article Nr.****Fitting Position**

<b>807 (E)</b>				<b>06/2002 → 05/2006</b>	
Top Strut Mounting	2.0, 2.0 16V, 2.0 HDi, 2.2, 2.2 HDi, 3.0 V6		<b>F8-5622</b>		
Belt Pulley, crankshaft	2.0 HDi, 2.2 HDi		<b>F8-5636</b>		d=30
Belt Pulley, crankshaft	2.0 HDi	ch.O09520→	<b>F8-5660</b>		
Belt Pulley, crankshaft	2.0 HDi	Orga.09520→	<b>F8-5660</b>		
Belt Pulley, crankshaft	2.2 HDi	Orga.10248→	<b>F8-5660</b>		
Engine Mounting	2.0, 2.0 16V, 2.0 HDi, 2.2, 2.2 HDi, 3.0 V6		<b>F8-6236</b>		H1=53; H2=40; d=10; D=70
Top Strut Mounting	2.0, 2.0 16V, 2.0 HDi, 2.2, 2.2 HDi, 3.0 V6		<b>F8-6304</b>		
Control Arm-/Trailing Arm Bush	2.0, 2.0 16V, 2.0 HDi, 2.2, 2.2 HDi, 3.0 V6		<b>F8-6439</b>		H=50; d=22.85; Inner Thread 1=M12 x 1,25 RHT F; Inner Thread 2=M12 x 1,25 RHT F; L=82
Engine Mounting	2.0		<b>F8-6507</b>		
Engine Mounting	2.0 16V, 2.0 HDi, 2.2, 2.2 HDi		<b>F8-6507</b>		
Top Strut Mounting	2.0, 2.0 16V, 2.0 HDi, 2.2, 2.2 HDi, 3.0 V6		<b>F8-7164</b>		
Belt Pulley, crankshaft	3.0 V6		<b>F8-7874</b>		
Engine Mounting	2.0 HDi, 2.2, 2.2 HDi		<b>F8-8149</b>		
Engine Mounting	2.0 HDi, 2.2 HDi		<b>F8-8167</b>		
Engine Mounting	2.2 HDi, 3.0 V6		<b>F8-8202</b>		
<b>1007 (KM)</b>				<b>04/2005 →</b>	
Alternator Freewheel Clutch	1.4 HDi, 1.6 HDi		<b>F5-1046</b>		
Alternator Freewheel Clutch	1.4 HDi, 1.6 HDi		<b>F5-1048</b>		
Anti-Friction Bearing	All Models		<b>F8-3012</b>		H=20; d=66; D=100
Control Arm-/Trailing Arm Bush	All Models		<b>F8-5629</b>		
Belt Pulley, crankshaft	1.4	Number of Ribs: 5; Parameter: 6PK;	<b>F8-6394</b>		H=25; d=44.05; Mounting points diam.[mm]=9; D=148; D1=142.9
Belt Pulley, crankshaft	1.4 16V, 1.6 16V	Number of Ribs: 5; Parameter: 6PK	<b>F8-6394</b>		H=25; d=44.05; Mounting points diam.[mm]=9; D=148; D1=142.9
Top Strut Mounting	All Models		<b>F8-6516</b>		
Control Arm-/Trailing Arm Bush	1.4 HDi	DV4TD; Orga.→10947	<b>F8-6535</b>		d=18; D=55.2, 73; Thick. [mm]=48
Control Arm-/Trailing Arm Bush	1.4, 1.4 16V, 1.6 16V	Orga.→10947	<b>F8-6535</b>		d=18; D=55.2, 73; Thick. [mm]=48
Control Arm-/Trailing Arm Bush	1.6 HDi		<b>F8-6535</b>		d=18; D=55.2, 73; Thick. [mm]=48
Spring Cap	All Models		<b>F8-6562</b>		
Rubber Buffer, suspension	All Models		<b>F8-7586</b>		H=78
Engine Mounting	All Models		<b>F8-8141</b>		

<b>F5-1046</b>	<b>F5-1048</b>	<b>F8-3012</b>	<b>F8-5622</b>	<b>F8-5629</b>	<b>F8-5636</b>	<b>F8-5660</b>
Ref.Nr.: 30667687	Ref.Nr.: 77363468	Ref.Nr.: 503527	Ref.Nr.: 503868	Ref.Nr.: 9636181080	Ref.Nr.: 0515P2	Ref.Nr.: 0515R9
<b>F8-6236</b>	<b>F8-6304</b>	<b>F8-6394</b>	<b>F8-6439</b>	<b>F8-6507</b>	<b>F8-6516</b>	<b>F8-6535</b>
Ref.Nr.: 1809.21	Ref.Nr.: 1311930080	Ref.Nr.: 0515.R8	Ref.Nr.: 1312317080	Ref.Nr.: 1827.16	Ref.Nr.: 5038F5	Ref.Nr.: 3523.AA
<b>F8-6562</b>	<b>F8-7164</b>	<b>F8-7586</b>	<b>F8-7874</b>	<b>F8-8141</b>	<b>F8-8149</b>	<b>F8-8167</b>
Ref.Nr.: 5033.75	Ref.Nr.: 503555	Ref.Nr.: 5166.67	Ref.Nr.: 0515.S2	Ref.Nr.: 180659	Ref.Nr.: 1844.93	Ref.Nr.: 9631575180

**Article Description**

**Article Nr.**
**Fitting Position**

2008		03/2013 →	
Engine Mounting	1.4 HDi, 1.6 VTi	F8-8141	
3008		06/2009 →	
Dust Cover Kit, shock absorber	1.6 HDi, 1.6 VTi	AK-735068	
Alternator Freewheel Clutch	1.6 HDi	F5-1046	
Alternator Freewheel Clutch	1.6 HDi	F5-1048	
Alternator Freewheel Clutch	1.6 THP, 1.6 VTi	F5-1113	
Alternator Freewheel Clutch	1.6 THP, 1.6 VTi	F5-1132	
Anti-Friction Bearing	1.6 HDi, 1.6 THP, 1.6 VTi, 2.0 HDi, 2.0 Hybrid4	F8-3012	⊕ ⊕ H=20; d=66; D=100
Control Arm-/Trailing Arm Bush	1.6 HDi, 1.6 THP, 2.0 Hybrid4	F8-6134	L=56.2; D=55.5
Control Arm-/Trailing Arm Bush	1.6 VTi	F8-6134	L=56.2; D=55.5
Control Arm-/Trailing Arm Bush	2.0 HDi	F8-6134	L=56.2; D=55.5
Engine Mounting	1.6 HDi	F8-6500	⊕ 6-speed
Engine Mounting	1.6 HDi, 1.6 THP	F8-6500	⊕ Transmission Type: MC
Engine Mounting	1.6 VTi	F8-6500	⊕ EP6;
Engine Mounting	2.0 HDi	F8-6500	⊕
Rubber Buffer, suspension	1.6 HDi, 1.6 THP, 1.6 VTi, 2.0 HDi, 2.0 Hybrid4	F8-6564	⊕ ⊕
Rubber Buffer, suspension	1.6 HDi, 1.6 VTi	F8-7585	⊕ ⊕ ⊕ H=96
Rubber Buffer, suspension	1.6 THP, 2.0 HDi, 2.0 Hybrid4	F8-7848	⊕ ⊕ ⊕ H=96
Control Arm-/Trailing Arm Bush	2.0 Hybrid4	G9-699	⊕ ⊕ ⊕ ↓ H=48.8; d=14; D=55.4
4007 (GP_)		02/2007 →	
Alternator Freewheel Clutch	2.2 HDi	F5-1131	
4008		05/2012 →	
Rubber Buffer, suspension	1.6 HDi AWC, 1.8 HDi AWC, 2.0 AWC	F8-7490	⊕ ⊕ ⊕
Rubber Buffer, suspension	1.6 HDi AWC, 1.8 HDi AWC, 2.0 AWC	F8-7491	⊕ ⊕ ⊕ Orga. → 13114; ⊕
5008		06/2009 →	
Dust Cover Kit, shock absorber	1.6 16V, 1.6 HDi	AK-735068	
Alternator Freewheel Clutch	1.6 HDi	F5-1046	
Alternator Freewheel Clutch	1.6 HDi	F5-1048	
Alternator Freewheel Clutch	1.6 16V	F5-1113	
Alternator Freewheel Clutch	1.6 16V	F5-1132	
Control Arm-/Trailing Arm Bush	1.6 16V	F8-6134	L=56.2; D=55.5

<b>AK-735068</b>	<b>F5-1046</b>	<b>F5-1048</b>	<b>F5-1113</b>	<b>F5-1131</b>	<b>F5-1132</b>	<b>F8-3012</b>
Ref.Nr.: 503370	Ref.Nr.: 30667687	Ref.Nr.: 77363468	Ref.Nr.: 12317576515	Ref.Nr.:	Ref.Nr.:	Ref.Nr.: 503527
<b>F8-6134</b>	<b>F8-6500</b>	<b>F8-6564</b>	<b>F8-7490</b>	<b>F8-7491</b>	<b>F8-7585</b>	<b>F8-7848</b>
Ref.Nr.: 3523.91	Ref.Nr.: 1844.36	Ref.Nr.: 503371	Ref.Nr.: 505443	Ref.Nr.: 516698	Ref.Nr.: 5033.70	Ref.Nr.: 5033.E4
<b>F8-8141</b>	<b>G9-699</b>					
Ref.Nr.: 180659	Ref.Nr.: 96286665					

**Article Description****Article Nr.****Fitting Position**

<b>5008</b>				<b>06/2009 →</b>	
Control Arm-/Trailing Arm Bush	1.6 16V, 1.6 HDi, 2.0 HDi		<b>F8-6134</b>		L=56.2; D=55.5
Engine Mounting	1.6 16V, 1.6 HDi		<b>F8-6500</b>		
Engine Mounting	2.0 HDi		<b>F8-6500</b>		
Engine Mounting	2.0 HDi	DW10CTED4;	<b>F8-6500</b>		
Rubber Buffer, suspension	1.6 16V, 1.6 HDi, 2.0 HDi		<b>F8-6564</b>		
Rubber Buffer, suspension	1.6 16V, 1.6 HDi		<b>F8-7585</b>		H=96
Rubber Buffer, suspension	1.6 16V, 2.0 HDi		<b>F8-7848</b>		H=96
<b>BIPPER (AA_)</b>				<b>02/2008 →</b>	
Alternator Freewheel Clutch	1.4 HDi		<b>F5-1048</b>		
Belt Pulley, crankshaft	1.4	Number of Ribs: 5; Parameter: 6PK	<b>F8-6394</b>		H=25; d=44.05; Mounting points diam.[mm]=9; D=148; D1=142.9
Top Strut Mounting	All Models		<b>F8-7428</b>		
Top Strut Mounting	All Models		<b>F8-7429</b>		
<b>BIPPER Tepee</b>				<b>04/2008 →</b>	
Belt Pulley, crankshaft	1.4	Number of Ribs: 5; Parameter: 6PK	<b>F8-6394</b>		H=25; d=44.05; Mounting points diam.[mm]=9; D=148; D1=142.9
Top Strut Mounting	1.3 HDi 75, 1.4, 1.4 HDi		<b>F8-7428</b>		
Top Strut Mounting	1.3 HDi 75, 1.4, 1.4 HDi		<b>F8-7429</b>		
<b>BOXER Bus (230P)</b>				<b>03/1994 → 04/2002</b>	
Dust Cover Kit, shock absorber	1.9 D, 1.9 TD, 1.9 TD 4x4, 2.0 i, 2.0 i 4x4, 2.5 D, 2.5 D 4x4, 2.5 TD, 2.5 TD 4x4, 2.5 TDI, 2.5 TDI 4x4, 2.8 HDI		<b>AK-735070</b>		
Alternator Freewheel Clutch	2.5 DT, 2.8 D, 2.8 HDi, 2.8 HDi 4x4, 2.8 HDi All-wheel Drive		<b>F5-1020</b>		
Anti-Friction Bearing	1.9 TD, 2.5 D, 2.5 D 4x4, 2.5 TD, 2.5 TD 4x4, 2.5 TDI, 2.5 TDI 4x4		<b>F8-3013</b>		H=7; d=49; D=71
Anti-Friction Bearing	1.9 D, 1.9 TD, 1.9 TD 4x4, 2.0 i, 2.0 i 4x4, 2.5 D, 2.5 D 4x4, 2.5 TD, 2.5 TD 4x4, 2.5 TDI, 2.5 TDI 4x4		<b>F8-3023</b>		H=9; d=49; D=71
Top Strut Mounting	1.9 D, 1.9 TD, 1.9 TD 4x4, 2.0 i, 2.0 i 4x4, 2.5 D, 2.5 D 4x4, 2.5 TD, 2.5 TD 4x4, 2.5 TDI, 2.5 TDI 4x4, 2.8 HDI	also for special vehicles;	<b>F8-5353</b>		
Top Strut Mounting	1.9 D, 1.9 TD, 1.9 TD 4x4, 2.0 i, 2.0 i 4x4, 2.5 D, 2.5 D 4x4, 2.5 TD, 2.5 TD 4x4, 2.5 TDI, 2.5 TDI 4x4, 2.8 HDI	also for special vehicles;	<b>F8-5354</b>		
Belt Pulley, crankshaft	1.9 D, 1.9 TD, 1.9 TD 4x4	Number of Ribs: 6;	<b>F8-5643</b>		Belt Pulley Ø [mm]=156; W=44
Mounting, leaf spring	1.9 D, 1.9 TD, 2.0 i, 2.0 i 4x4, 2.5 D, 2.5 D 4x4, 2.5 DT, 2.5 TD, 2.5 TD 4x4, 2.5 TDI, 2.5 TDI 4x4, 2.8 D, 2.8 HDI, 2.8 HDi 4x4		<b>F8-5897</b>		H=46.5; d=16; D=40
Mounting, leaf spring	1.9 D, 1.9 TD, 2.0 i, 2.5 D, 2.5 D 4x4, 2.5 TD, 2.5 TD 4x4, 2.5 TDI, 2.5 TDI 4x4		<b>F8-5898</b>		H=87; d=16; D=50

<b>AK-735070</b>	<b>F5-1020</b>	<b>F5-1048</b>	<b>F8-3013</b>	<b>F8-3023</b>	<b>F8-5353</b>	<b>F8-5354</b>
Ref.Nr.:	Ref.Nr.: 31771-68D01	Ref.Nr.: 77363468	Ref.Nr.: 503517	Ref.Nr.: 503547	Ref.Nr.: 5038.19	Ref.Nr.: 5038.18
<b>F8-5643</b>	<b>F8-5897</b>	<b>F8-5898</b>	<b>F8-6114</b>	<b>F8-6134</b>	<b>F8-6394</b>	<b>F8-6500</b>
Ref.Nr.: 96089 38980	Ref.Nr.: 1304640080	Ref.Nr.: 5131.73	Ref.Nr.: 1320755080-PA	Ref.Nr.: 3523.91	Ref.Nr.: 0515.R8	Ref.Nr.: 1844.36
<b>F8-6564</b>	<b>F8-7428</b>	<b>F8-7429</b>	<b>F8-7585</b>	<b>F8-7848</b>		
Ref.Nr.: 503371	Ref.Nr.: 5038J8	Ref.Nr.: 5038G8	Ref.Nr.: 5033.70	Ref.Nr.: 5033.E4		

Article Description

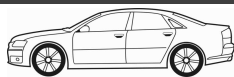

Article Nr.

Fitting Position



<b>BOXER Bus (230P)</b>		<b>03/1994 → 04/2002</b>	
Control Arm-/Trailing Arm Bush	1.9 D, 1.9 TD, 1.9 TD 4x4, 2.0 i, 2.0 i 4x4, 2.5 D, 2.5 D 4x4, 2.5 DT, 2.5 TD, 2.5 TD 4x4, 2.5 TDI, 2.5 TDI 4x4, 2.8 HDI, 2.8 HDi 4x4, 2.8 HDi All-wheel Drive	for OE: 1320755080, 1320756080, 3520.N3, 3520.N4, 3521.J3, 3521.J4	<b>F8-6114</b>
Control Arm-/Trailing Arm Bush	1.9 D, 1.9 TD, 1.9 TD 4x4, 2.0 i, 2.0 i 4x4, 2.5 D, 2.5 D 4x4, 2.5 DT, 2.5 TD, 2.5 TD 4x4, 2.5 TDI, 2.5 TDI 4x4, 2.8 HDI, 2.8 HDi 4x4		<b>F8-6115</b> H=55; d=25.5; D1=56; D2=45
Top Strut Mounting	1.9 D, 1.9 TD, 1.9 TD 4x4, 2.0 i, 2.0 i 4x4, 2.5 D, 2.5 D 4x4, 2.5 TD, 2.5 TD 4x4, 2.5 TDI, 2.5 TDI 4x4, 2.8 HDI		<b>F8-6306</b>
Belt Pulley, crankshaft	2.5 D, 2.5 D 4x4, 2.5 TD, 2.5 TD 4x4, 2.5 TDI, 2.5 TDI 4x4		<b>F8-6395</b>
Control Arm-/Trailing Arm Bush	1.9 D, 1.9 TD, 2.0 i, 2.0 i 4x4, 2.5 D, 2.5 D 4x4, 2.5 DT, 2.5 TD, 2.5 TD 4x4, 2.5 TDI, 2.5 TDI 4x4, 2.8 HDI, 2.8 HDi 4x4		<b>F8-6452</b>
Engine Mounting	1.9 D, 1.9 TD, 1.9 TD 4x4, 2.0 i, 2.0 i 4x4, 2.5 D, 2.5 D 4x4, 2.5 TD, 2.5 TD 4x4, 2.5 TDI, 2.5 TDI 4x4, 2.8 HDI, 2.8 HDi 4x4		<b>F8-6485</b>
Engine Mounting	1.9 TD, 2.0 i, 2.0 i 4x4, 2.8 HDI	[kg]: 1800	<b>F8-6520</b>
Engine Mounting	2.5 D, 2.5 D 4x4, 2.5 TD, 2.5 TD 4x4, 2.5 TDI, 2.5 TDI 4x4	[kg]: 1800; Transmission Type: MG5T	<b>F8-6520</b>
Engine Mounting	2.5 D, 2.5 D 4x4, 2.5 TD, 2.5 TD 4x4, 2.5 TDI, 2.5 TDI 4x4		<b>F8-6888</b>
Engine Mounting	1.9 D, 1.9 TD, 1.9 TD 4x4		<b>F8-6891</b>
Engine Mounting	1.9 D, 1.9 TD, 1.9 TD 4x4, 2.0 i, 2.0 i 4x4, 2.5 D, 2.5 D 4x4, 2.5 TD, 2.5 TD 4x4, 2.5 TDI, 2.5 TDI 4x4, 2.8 HDI		<b>F8-6918</b>
Belt Pulley, crankshaft	1.9 D, 1.9 TD	09/1998 →; Number of Ribs: 6	<b>F8-7079</b>
Belt Pulley, crankshaft	1.9 TD	10/1996 →; Number of Ribs: 6	<b>F8-7079</b>
Belt Pulley, crankshaft	2.8 HDI	Number of Ribs: 6	<b>F8-7081</b>
Top Strut Mounting	1.9 D, 1.9 TD, 1.9 TD 4x4, 2.0 i, 2.0 i 4x4, 2.5 D, 2.5 D 4x4, 2.5 TD, 2.5 TD 4x4, 2.5 TDI, 2.5 TDI 4x4, 2.8 HDI		<b>F8-7154</b>
Belt Pulley, crankshaft	1.9 D, 1.9 TD, 1.9 TD 4x4	10/1996 →;	<b>F8-7863</b>
Top Strut Mounting	1.9 D, 1.9 TD, 1.9 TD 4x4, 2.0 i, 2.0 i 4x4, 2.5 D, 2.5 D 4x4, 2.5 TD, 2.5 TD 4x4, 2.5 TDI, 2.5 TDI 4x4	ch.→15616153; not for special purpose vehicles; ;	<b>F8-8066</b>
Top Strut Mounting	1.9 D, 1.9 TD, 1.9 TD 4x4, 2.0 i, 2.0 i 4x4, 2.5 D, 2.5 D 4x4, 2.5 TD, 2.5 TD 4x4, 2.5 TDI, 2.5 TDI 4x4	ch.→15616153; not for special purpose vehicles; ;	<b>F8-8066</b>
Top Strut Mounting	1.9 D, 1.9 TD, 1.9 TD 4x4, 2.0 i, 2.0 i 4x4, 2.5 D, 2.5 D 4x4, 2.5 TD, 2.5 TD 4x4, 2.5 TDI, 2.5 TDI 4x4	ch.15616154→; not for special purpose vehicles; ;	<b>F8-8066</b>
Top Strut Mounting	1.9 D, 1.9 TD, 1.9 TD 4x4, 2.0 i, 2.0 i 4x4, 2.5 D, 2.5 D 4x4, 2.5 TD, 2.5 TD 4x4, 2.5 TDI, 2.5 TDI 4x4	ch.15616154→; not for special purpose vehicles; ;	<b>F8-8066</b>
Top Strut Mounting	2.8 D, 2.8 HDI, 2.8 HDi 4x4	not for special purpose vehicles;	<b>F8-8066</b>
Top Strut Mounting	1.9 D, 1.9 TD, 1.9 TD 4x4, 2.0 i, 2.0 i 4x4, 2.5 D, 2.5 D 4x4, 2.5 TD, 2.5 TD 4x4, 2.5 TDI, 2.5 TDI 4x4	ch.→15616153; not for special purpose vehicles; ;	<b>F8-8067</b>

<b>F8-6114</b>	<b>F8-6115</b>	<b>F8-6306</b>	<b>F8-6395</b>	<b>F8-6452</b>	<b>F8-6485</b>	<b>F8-6520</b>
Ref.Nr.: 1320755080-PA	Ref.Nr.: 3523.93	Ref.Nr.: 503547	Ref.Nr.: 0515.H3	Ref.Nr.: 3523.93	Ref.Nr.: 1846.66	Ref.Nr.: 1307908080
<b>F8-6888</b>	<b>F8-6891</b>	<b>F8-6918</b>	<b>F8-7079</b>	<b>F8-7081</b>	<b>F8-7154</b>	<b>F8-7863</b>
Ref.Nr.: 1307907080	Ref.Nr.: 1307906080	Ref.Nr.: 1310575080	Ref.Nr.: 0515.K4	Ref.Nr.: 0515.T4	Ref.Nr.: 503530	Ref.Nr.: 0515K4
<b>F8-8066</b>	<b>F8-8067</b>					
Ref.Nr.: 5038.72	Ref.Nr.: 5038.74					



**Article Description****Article Nr.****Fitting Position**

<b>BOXER Bus (230P)</b>		<b>03/1994 → 04/2002</b>	
Top Strut Mounting	1.9 D, 1.9 TD, 1.9 TD 4x4, 2.0 i, 2.0 i 4x4, 2.5 D, 2.5 D 4x4, 2.5 TD, 2.5 TD 4x4, 2.5 TDI, 2.5 TDI 4x4	ch.→15616153; not for special purpose vehicles;	<b>F8-8067</b>
Top Strut Mounting	1.9 D, 1.9 TD, 1.9 TD 4x4, 2.0 i, 2.0 i 4x4, 2.5 D, 2.5 D 4x4, 2.5 TD, 2.5 TD 4x4, 2.5 TDI, 2.5 TDI 4x4	ch.15616154→; not for special purpose vehicles;	<b>F8-8067</b>
Top Strut Mounting	1.9 D, 1.9 TD, 1.9 TD 4x4, 2.0 i, 2.0 i 4x4, 2.5 D, 2.5 D 4x4, 2.5 TD, 2.5 TD 4x4, 2.5 TDI, 2.5 TDI 4x4	ch.15616154→; not for special purpose vehicles;	<b>F8-8067</b>
Top Strut Mounting	2.8 D, 2.8 HDi, 2.8 HDi 4x4	not for special purpose vehicles;	<b>F8-8067</b>
Bellow, steering	1.9 D, 1.9 TD, 1.9 TD 4x4, 2.0 i, 2.0 i 4x4, 2.5 D, 2.5 D 4x4, 2.5 TD, 2.5 TD 4x4, 2.5 TDI, 2.5 TDI 4x4, 2.8 HDi	Orga.→13502; with clamps;	<b>LM-10018S</b> d1=15; d2=54; L [mm]=264
<b>BOXER Box (230L)</b>		<b>03/1994 → 04/2002</b>	
Dust Cover Kit, shock absorber	1.9 D, 1.9 TD, 2.0 HDi, 2.0 i, 2.5 D, 2.5 D 4x4, 2.5 TD, 2.5 TDI, 2.5 TDI 4x4, 2.8 HDi	[kg]: 1000, 1400	<b>AK-735070</b>
Alternator Freewheel Clutch	2.5 DT, 2.8 D, 2.8 HDi, 2.8 HDi 4x4		<b>F5-1020</b>
Anti-Friction Bearing	2.5 D, 2.5 D 4x4, 2.5 TD, 2.5 TDI, 2.5 TDI 4x4		<b>F8-3013</b>
Anti-Friction Bearing	1.9 D, 1.9 TD, 2.0 i, 2.5 D, 2.5 TD, 2.5 TDI		<b>F8-3023</b>
Top Strut Mounting	1.9 D, 1.9 TD, 2.0 HDi, 2.0 i, 2.5 D, 2.5 D 4x4, 2.5 TD, 2.5 TDI, 2.5 TDI 4x4, 2.8 HDi	also for special vehicles;	<b>F8-5353</b>
Top Strut Mounting	1.9 D, 1.9 TD, 2.0 HDi, 2.0 i, 2.5 D, 2.5 D 4x4, 2.5 TD, 2.5 TDI, 2.5 TDI 4x4, 2.8 HDi	also for special vehicles;	<b>F8-5354</b>
Belt Pulley, crankshaft	1.9 D, 1.9 DT 4x4, 1.9 TD	Number of Ribs: 6;	<b>F8-5643</b>
Mounting, leaf spring	1.9 D, 1.9 TD, 2.0 4x4, 2.0 HDi, 2.0 i, 2.5 D, 2.5 D 4x4, 2.5 DT, 2.5 TD, 2.5 TDI, 2.5 TDI 4x4, 2.8 D, 2.8 HDi, 2.8 HDi 4x4		<b>F8-5897</b>
Mounting, leaf spring	1.9 D, 1.9 TD, 2.0 i, 2.5 D, 2.5 D 4x4, 2.5 TD, 2.5 TDI, 2.5 TDI 4x4		<b>F8-5898</b>
Control Arm-/Trailing Arm Bush	1.9 D, 1.9 DT 4x4, 1.9 TD, 2.0 4x4, 2.0 HDi, 2.0 i, 2.5 D, 2.5 D 4x4, 2.5 DT, 2.5 TD, 2.5 TDI, 2.5 TDI 4x4, 2.8 HDi, 2.8 HDi 4x4	for OE: 1320755080, 1320756080, 3520.N3, 3520.N4, 3521.J3, 3521.J4	<b>F8-6114</b>
Control Arm-/Trailing Arm Bush	1.9 D, 1.9 TD, 2.0 4x4, 2.0 HDi, 2.0 i, 2.5 D, 2.5 D 4x4, 2.5 DT, 2.5 TD, 2.5 TDI, 2.5 TDI 4x4, 2.8 HDi, 2.8 HDi 4x4		<b>F8-6115</b>
Top Strut Mounting	1.9 D, 1.9 TD, 2.0 HDi, 2.0 i, 2.5 D, 2.5 D 4x4, 2.5 TD, 2.5 TDI 4x4, 2.8 HDi		<b>F8-6306</b>
Belt Pulley, crankshaft	2.5 D, 2.5 D 4x4, 2.5 TD, 2.5 TDI, 2.5 TDI 4x4		<b>F8-6395</b>
Control Arm-/Trailing Arm Bush	1.9 D, 1.9 TD, 2.0 4x4, 2.0 HDi, 2.0 i, 2.5 D, 2.5 D 4x4, 2.5 DT, 2.5 TD, 2.5 TDI, 2.5 TDI 4x4, 2.8 HDi, 2.8 HDi 4x4		<b>F8-6452</b>
Engine Mounting	1.9 D, 1.9 TD, 2.0 4x4, 2.0 HDi, 2.0 i, 2.5 D, 2.5 D 4x4, 2.5 TD, 2.5 TDI, 2.5 TDI 4x4, 2.8 HDi, 2.8 HDi 4x4		<b>F8-6485</b>
Engine Mounting	1.9 D, 1.9 TD, 2.0 4x4, 2.8 HDi	[kg]: 1800	<b>F8-6520</b>
Engine Mounting	2.5 D, 2.5 D 4x4, 2.5 TD, 2.5 TDI, 2.5 TDI 4x4	[kg]: 1800; Transmission Type: MG5T	<b>F8-6520</b>
Engine Mounting	2.5 D, 2.5 D 4x4, 2.5 TD, 2.5 TDI, 2.5 TDI 4x4		<b>F8-6888</b>

<b>AK-735070</b>	<b>F5-1020</b>	<b>F8-3013</b>	<b>F8-3023</b>	<b>F8-5353</b>	<b>F8-5354</b>	<b>F8-5643</b>
Ref.Nr.:	Ref.Nr.: 31771-68D01	Ref.Nr.: 503517	Ref.Nr.: 503547	Ref.Nr.: 5038.19	Ref.Nr.: 5038.18	Ref.Nr.: 96089 38980
<b>F8-5897</b>	<b>F8-5898</b>	<b>F8-6114</b>	<b>F8-6115</b>	<b>F8-6306</b>	<b>F8-6395</b>	<b>F8-6452</b>
Ref.Nr.: 1304640080	Ref.Nr.: 5131.73	Ref.Nr.: 1320755080-PA	Ref.Nr.: 3523.93	Ref.Nr.: 503547	Ref.Nr.: 0515.H3	Ref.Nr.: 3523.93
<b>F8-6485</b>	<b>F8-6520</b>	<b>F8-6888</b>	<b>F8-6891</b>	<b>F8-8067</b>	<b>LM-10018S</b>	
Ref.Nr.: 1846.66	Ref.Nr.: 1307908080	Ref.Nr.: 1307907080	Ref.Nr.: 1307906080	Ref.Nr.: 5038.74	Ref.Nr.: 4018.A5	

Article Description



Article Nr.

Fitting Position



<b>BOXER Box (230L)</b>		<b>03/1994 → 04/2002</b>	
Engine Mounting	1.9 D, 1.9 TD		<b>F8-6891</b>
Engine Mounting	1.9 D, 1.9 TD, 2.0 i, 2.5 D, 2.5 D 4x4, 2.5 TD, 2.5 TDI, 2.5 TDI 4x4, 2.8 HDI		<b>F8-6918</b>
Belt Pulley, crankshaft	1.9 D, 1.9 TD	Number of Ribs: 6	<b>F8-7079</b>
Belt Pulley, crankshaft	2.8 HDI	Number of Ribs: 6	<b>F8-7081</b>
Top Strut Mounting	1.9 D, 1.9 TD, 2.0 HDI, 2.0 i, 2.5 D, 2.5 D 4x4, 2.5 TD, 2.5 TDI 4x4, 2.8 HDI		<b>F8-7154</b>
Belt Pulley, crankshaft	1.9 D, 1.9 DT 4x4, 1.9 TD	10/1996 →;	<b>F8-7863</b>
Belt Pulley, crankshaft	1.9 D, 1.9 TD		<b>F8-7863</b>
Top Strut Mounting	1.9 D, 1.9 TD, 2.0 HDI, 2.0 i, 2.5 D, 2.5 D 4x4, 2.5 TD, 2.5 TDI, 2.5 TDI 4x4	ch.→15616153; not for special purpose vehicles; ;	<b>F8-8066</b>
Top Strut Mounting	1.9 D, 1.9 TD, 2.0 HDI, 2.0 i, 2.5 D, 2.5 D 4x4, 2.5 TD, 2.5 TDI, 2.5 TDI 4x4	ch.→15616153; not for special purpose vehicles; ;	<b>F8-8066</b>
Top Strut Mounting	1.9 D, 1.9 TD, 2.0 HDI, 2.0 i, 2.5 D, 2.5 D 4x4, 2.5 TD, 2.5 TDI, 2.5 TDI 4x4	ch.15616154→; not for special purpose vehicles; ;	<b>F8-8066</b>
Top Strut Mounting	1.9 D, 1.9 TD, 2.0 HDI, 2.0 i, 2.5 D, 2.5 D 4x4, 2.5 TD, 2.5 TDI, 2.5 TDI 4x4	ch.15616154→; not for special purpose vehicles; ;	<b>F8-8066</b>
Top Strut Mounting	2.8 HDI	not for special purpose vehicles;	<b>F8-8066</b>
Top Strut Mounting	1.9 D, 1.9 TD, 2.0 HDI, 2.0 i, 2.5 D, 2.5 D 4x4, 2.5 TD, 2.5 TDI, 2.5 TDI 4x4	ch.→15616153; not for special purpose vehicles; ;	<b>F8-8067</b>
Top Strut Mounting	1.9 D, 1.9 TD, 2.0 HDI, 2.0 i, 2.5 D, 2.5 D 4x4, 2.5 TD, 2.5 TDI, 2.5 TDI 4x4	ch.→15616153; not for special purpose vehicles; ;	<b>F8-8067</b>
Top Strut Mounting	1.9 D, 1.9 TD, 2.0 HDI, 2.0 i, 2.5 D, 2.5 D 4x4, 2.5 TD, 2.5 TDI, 2.5 TDI 4x4	ch.15616154→; not for special purpose vehicles; ;	<b>F8-8067</b>
Top Strut Mounting	1.9 D, 1.9 TD, 2.0 HDI, 2.0 i, 2.5 D, 2.5 D 4x4, 2.5 TD, 2.5 TDI, 2.5 TDI 4x4	ch.15616154→; not for special purpose vehicles; ;	<b>F8-8067</b>
Top Strut Mounting	2.8 HDI	not for special purpose vehicles;	<b>F8-8067</b>
Bellow, steering	1.9 D, 1.9 TD, 2.0 HDI, 2.0 i, 2.5 D, 2.5 D 4x4, 2.5 TD, 2.5 TDI, 2.5 TDI 4x4, 2.8 HDI	Orga.→13502; with clamps;	<b>LM-10018S</b>
<b>BOXER Platform/Chassis (ZCT)</b>		<b>03/1994 → 04/2002</b>	
Dust Cover Kit, shock absorber	1.9 TD, 2.0 i, 2.5 D, 2.5 D 4x4, 2.5 TD, 2.5 TDI, 2.5 TDI 4x4, 2.8 HDI	[kg]: 1000, 1400	<b>AK-735070</b>
Alternator Freewheel Clutch	2.8 D, 2.8 HDI, 2.8 HDI All-wheel Drive		<b>F5-1020</b>
Anti-Friction Bearing	1.9 TD, 2.5 D, 2.5 D 4x4, 2.5 TD, 2.5 TDI, 2.5 TDI 4x4		<b>F8-3013</b> H=7; d=49; D=71
Anti-Friction Bearing	2.0 i, 2.5 D, 2.5 TD, 2.5 TDI		<b>F8-3023</b> H=9; d=49; D=71
Top Strut Mounting	1.9 TD, 2.0 i, 2.5 D, 2.5 D 4x4, 2.5 TD, 2.5 TDI, 2.5 TDI 4x4, 2.8 HDI	also for special vehicles;	<b>F8-5353</b>
Top Strut Mounting	1.9 TD, 2.0 i, 2.5 D, 2.5 D 4x4, 2.5 TD, 2.5 TDI, 2.5 TDI 4x4, 2.8 HDI	also for special vehicles;	<b>F8-5354</b>
Belt Pulley, crankshaft	1.9 TD	Number of Ribs: 6;	<b>F8-5643</b>

<b>AK-735070</b>	<b>F5-1020</b>	<b>F8-3013</b>	<b>F8-3023</b>	<b>F8-5353</b>	<b>F8-5354</b>	<b>F8-5643</b>
Ref.Nr.:	Ref.Nr.: 31771-68D01	Ref.Nr.: 503517	Ref.Nr.: 503547	Ref.Nr.: 5038.19	Ref.Nr.: 5038.18	Ref.Nr.: 96089 38980
<b>F8-5897</b>	<b>F8-6891</b>	<b>F8-6918</b>	<b>F8-7079</b>	<b>F8-7081</b>	<b>F8-7154</b>	<b>F8-7863</b>
Ref.Nr.: 1304640080	Ref.Nr.: 1307906080	Ref.Nr.: 1310575080	Ref.Nr.: 0515.K4	Ref.Nr.: 0515.T4	Ref.Nr.: 503530	Ref.Nr.: 0515K4
<b>F8-8066</b>	<b>F8-8067</b>	<b>LM-10018S</b>				
Ref.Nr.: 5038.72	Ref.Nr.: 5038.74	Ref.Nr.: 4018.A5				

**Article Description****Article Nr.****Fitting Position**

<b>BOXER Platform/Chassis (ZCT)</b>			<b>03/1994 → 04/2002</b>		
Mounting, leaf spring	1.9 TD, 2.0, 2.0 i, 2.5 D, 2.5 D 4x4, 2.5 TD, 2.5 TDI, 2.5 TDI 4x4, 2.8 D, 2.8 HDI, 2.8 HDi All-wheel Drive		<b>F8-5897</b>		H=46.5; d=16; D=40
Mounting, leaf spring	1.9 TD, 2.0 i, 2.5 D, 2.5 D 4x4, 2.5 TD, 2.5 TDI, 2.5 TDI 4x4		<b>F8-5898</b>		H=87; d=16; D=50
Control Arm-/Trailing Arm Bush	1.9 TD, 2.0, 2.0 i, 2.5 D, 2.5 D 4x4, 2.5 TD, 2.5 TDI, 2.5 TDI 4x4, 2.8 HDI, 2.8 HDi All-wheel Drive	for OE: 1320755080, 1320756080, 3520.N3, 3520.N4, 3521.J3, 3521.J4	<b>F8-6114</b>		
Control Arm-/Trailing Arm Bush	1.9 TD, 2.0, 2.0 i, 2.5 D, 2.5 D 4x4, 2.5 TD, 2.5 TDI, 2.5 TDI 4x4, 2.8 HDI, 2.8 HDi All-wheel Drive		<b>F8-6115</b>		H=55; d=25.5; D1=56; D2=45
Top Strut Mounting	1.9 TD, 2.0 i, 2.5 D, 2.5 D 4x4, 2.5 TD, 2.5 TDI, 2.5 TDI 4x4, 2.8 HDI		<b>F8-6306</b>		
Belt Pulley, crankshaft	2.5 D, 2.5 D 4x4, 2.5 TD, 2.5 TDI, 2.5 TDI 4x4		<b>F8-6395</b>		
Control Arm-/Trailing Arm Bush	1.9 TD, 2.0, 2.0 i, 2.5 D, 2.5 D 4x4, 2.5 TD, 2.5 TDI, 2.5 TDI 4x4, 2.8 HDI, 2.8 HDi All-wheel Drive		<b>F8-6452</b>		
Engine Mounting	1.9 TD, 2.0, 2.0 i, 2.5 D, 2.5 D 4x4, 2.5 TD, 2.5 TDI, 2.5 TDI 4x4, 2.8 HDI, 2.8 HDi All-wheel Drive		<b>F8-6485</b>		
Engine Mounting	2.5 D, 2.5 D 4x4, 2.5 TD, 2.5 TDI, 2.5 TDI 4x4	[kg]: 1800; Transmission Type: MG5T	<b>F8-6520</b>		
Engine Mounting	2.5 D, 2.5 D 4x4, 2.5 TD, 2.5 TDI, 2.5 TDI 4x4		<b>F8-6888</b>		
Engine Mounting	1.9 TD		<b>F8-6891</b>		
Engine Mounting	1.9 TD, 2.0 i, 2.5 D, 2.5 D 4x4, 2.5 TD, 2.5 TDI, 2.5 TDI 4x4, 2.8 HDI		<b>F8-6918</b>		
Belt Pulley, crankshaft	1.9 TD	09/1998 →; Number of Ribs: 6	<b>F8-7079</b>		Belt Pulley Ø [mm]=156; Mounting points diam.[mm]=30; W=44.7
Belt Pulley, crankshaft	1.9 TD	Number of Ribs: 6	<b>F8-7079</b>		Belt Pulley Ø [mm]=156; Mounting points diam.[mm]=30; W=44.7
Top Strut Mounting	1.9 TD, 2.0 i, 2.5 D, 2.5 D 4x4, 2.5 TD, 2.5 TDI, 2.5 TDI 4x4, 2.8 HDI		<b>F8-7154</b>		
Belt Pulley, crankshaft	1.9 TD	10/1996 →;	<b>F8-7863</b>		
Belt Pulley, crankshaft	1.9 TD		<b>F8-7863</b>		
Top Strut Mounting	1.9 TD, 2.0, 2.0 i, 2.5 D, 2.5 D 4x4, 2.5 TD, 2.5 TDI, 2.5 TDI 4x4	ch.→15616153; not for special purpose vehicles; ;	<b>F8-8066</b>		
Top Strut Mounting	1.9 TD, 2.0, 2.0 i, 2.5 D, 2.5 D 4x4, 2.5 TD, 2.5 TDI, 2.5 TDI 4x4	ch.→15616153; not for special purpose vehicles; ;	<b>F8-8066</b>		
Top Strut Mounting	1.9 TD, 2.0, 2.0 i, 2.5 D, 2.5 D 4x4, 2.5 TD, 2.5 TDI, 2.5 TDI 4x4	ch.15616154→; not for special purpose vehicles; ;	<b>F8-8066</b>		
Top Strut Mounting	1.9 TD, 2.0, 2.0 i, 2.5 D, 2.5 D 4x4, 2.5 TD, 2.5 TDI, 2.5 TDI 4x4	ch.15616154→; not for special purpose vehicles; ;	<b>F8-8066</b>		
Top Strut Mounting	2.8 HDI	not for special purpose vehicles;	<b>F8-8066</b>		
Top Strut Mounting	1.9 TD, 2.0, 2.0 i, 2.5 D, 2.5 D 4x4, 2.5 TD, 2.5 TDI, 2.5 TDI 4x4	ch.→15616153; not for special purpose vehicles; ;	<b>F8-8067</b>		
Top Strut Mounting	1.9 TD, 2.0, 2.0 i, 2.5 D, 2.5 D 4x4, 2.5 TD, 2.5 TDI, 2.5 TDI 4x4	ch.→15616153; not for special purpose vehicles; ;	<b>F8-8067</b>		

<b>F8-5897</b>	<b>F8-5898</b>	<b>F8-6114</b>	<b>F8-6115</b>	<b>F8-6306</b>	<b>F8-6395</b>	<b>F8-6452</b>
Ref.Nr.: 1304640080	Ref.Nr.: 5131.73	Ref.Nr.: 1320755080-PA	Ref.Nr.: 3523.93	Ref.Nr.: 503547	Ref.Nr.: 0515.H3	Ref.Nr.: 3523.93
<b>F8-6485</b>	<b>F8-6520</b>	<b>F8-6888</b>	<b>F8-6891</b>	<b>F8-6918</b>	<b>F8-7079</b>	<b>F8-7154</b>
Ref.Nr.: 1846.66	Ref.Nr.: 1307908080	Ref.Nr.: 1307907080	Ref.Nr.: 1307906080	Ref.Nr.: 1310575080	Ref.Nr.: 0515.K4	Ref.Nr.: 503530
<b>F8-7863</b>	<b>F8-8066</b>	<b>F8-8067</b>				
Ref.Nr.: 0515K4	Ref.Nr.: 5038.72	Ref.Nr.: 5038.74				

Article Description

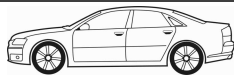

Article Nr.

Fitting Position



<b>BOXER Platform/Chassis (ZCT_)</b>		03/1994 → 04/2002	
Top Strut Mounting	1.9 TD, 2.0, 2.0 i, 2.5 D, 2.5 D 4x4, 2.5 TD, 2.5 TDI, 2.5 TDI 4x4	ch.15616154→; not for special purpose vehicles; ;	<b>F8-8067</b>
Top Strut Mounting	1.9 TD, 2.0, 2.0 i, 2.5 D, 2.5 D 4x4, 2.5 TD, 2.5 TDI, 2.5 TDI 4x4	ch.15616154→; not for special purpose vehicles; ;	<b>F8-8067</b>
Top Strut Mounting	2.8 HDi	not for special purpose vehicles;	<b>F8-8067</b>
Bellow, steering	1.9 TD, 2.0 i, 2.5 D, 2.5 D 4x4, 2.5 TD, 2.5 TDI, 2.5 TDI 4x4, 2.8 HDi	Orga.→13502; with clamps;	<b>LM-10018S</b> d1=15; d2=54; L [mm]=264
<b>BOXER Bus (244, Z_)</b>		04/2002 →	
Dust Cover Kit, shock absorber	2.0, 2.0 HDi, 2.2 HDi, 2.8 HDi, 2.8 HDi 4x4		<b>AK-735070</b>
Alternator Freewheel Clutch	2.0 HDi, 2.2 HDi, 2.8 HDi, 2.8 HDi 4x4		<b>F5-1020</b>
Alternator Freewheel Clutch	2.0 HDi, 2.2 HDi		<b>F5-1046</b>
Alternator Freewheel Clutch	2.0 HDi, 2.2 HDi		<b>F5-1048</b>
Top Strut Mounting	2.0 HDi, 2.8 HDi	also for special vehicles;	<b>F8-5353</b>
Top Strut Mounting	2.0 HDi, 2.8 HDi	also for special vehicles;	<b>F8-5354</b>
Belt Pulley, crankshaft	2.0 HDi, 2.2 HDi		<b>F8-5636</b> d=30
Mounting, leaf spring	2.0, 2.0 HDi, 2.2 HDi, 2.8 HDi, 2.8 HDi 4x4		<b>F8-5897</b> H=46.5; d=16; D=40
Mounting, leaf spring	2.0 HDi		<b>F8-5898</b> H=87; d=16; D=50
Control Arm-/Trailing Arm Bush	2.0, 2.0 HDi, 2.2 HDi, 2.8 HDi, 2.8 HDi 4x4	ch.→17226522; for OE: 1320755080, 1320756080, 3520.N3, 3520.N4, 3521.J3, 3521.J4	<b>F8-6114</b>
Control Arm-/Trailing Arm Bush	2.0, 2.0 HDi, 2.2 HDi, 2.8 HDi, 2.8 HDi 4x4		<b>F8-6115</b> H=55; d=25.5; D1=56; D2=45
Top Strut Mounting	2.0, 2.0 HDi, 2.2 HDi, 2.8 HDi, 2.8 HDi 4x4		<b>F8-6306</b>
Control Arm-/Trailing Arm Bush	2.0, 2.0 HDi, 2.2 HDi, 2.8 HDi, 2.8 HDi 4x4		<b>F8-6452</b>
Engine Mounting	2.0 HDi	DW10TD	<b>F8-6485</b>
Engine Mounting	2.0, 2.2 HDi, 2.8 HDi, 2.8 HDi 4x4		<b>F8-6485</b>
Control Arm-/Trailing Arm Bush	2.0, 2.0 HDi, 2.2 HDi, 2.8 HDi, 2.8 HDi 4x4	ch.17226523→; for OE: 3520.N3, 3520.N4, 3521.J3, 3521.J4	<b>F8-6773</b>
Engine Mounting	2.0 HDi	DW10TD; Orga.09079→	<b>F8-6918</b>
Engine Mounting	2.2 HDi	Orga.09079→	<b>F8-6918</b>
Belt Pulley, crankshaft	2.8 HDi, 2.8 HDi 4x4	Number of Ribs: 6	<b>F8-7081</b> Belt Pulley Ø [mm]=146; W=56
Top Strut Mounting	2.0, 2.0 HDi, 2.2 HDi, 2.8 HDi, 2.8 HDi 4x4		<b>F8-7154</b>
Top Strut Mounting	2.0, 2.0 HDi, 2.2 HDi, 2.8 HDi, 2.8 HDi 4x4	not for special purpose vehicles; ;	<b>F8-8066</b>
Top Strut Mounting	2.0, 2.0 HDi, 2.2 HDi, 2.8 HDi, 2.8 HDi 4x4	not for special purpose vehicles; ;	<b>F8-8067</b>
<b>BOXER Box (244)</b>		04/2002 →	
Dust Cover Kit, shock absorber	2.0, 2.0 HDi, 2.2 HDi, 2.8 HDi, 2.8 HDi 4x4	[kg]: 1000, 1400	<b>AK-735070</b>
Alternator Freewheel Clutch	2.0 HDi, 2.2 HDi, 2.8 HDi, 2.8 HDi 4x4		<b>F5-1020</b>

<b>AK-735070</b>	<b>F5-1020</b>	<b>F5-1046</b>	<b>F5-1048</b>	<b>F8-5353</b>	<b>F8-5354</b>	<b>F8-5636</b>
Ref.Nr.:	Ref.Nr.: 31771-68D01	Ref.Nr.: 30667687	Ref.Nr.: 77363468	Ref.Nr.: 5038.19	Ref.Nr.: 5038.18	Ref.Nr.: 0515P2
<b>F8-5897</b>	<b>F8-5898</b>	<b>F8-6114</b>	<b>F8-6115</b>	<b>F8-6306</b>	<b>F8-6452</b>	<b>F8-6485</b>
Ref.Nr.: 1304640080	Ref.Nr.: 5131.73	Ref.Nr.: 1320755080-PA	Ref.Nr.: 3523.93	Ref.Nr.: 503547	Ref.Nr.: 3523.93	Ref.Nr.: 1846.66
<b>F8-6773</b>	<b>F8-6918</b>	<b>F8-7081</b>	<b>F8-7154</b>	<b>F8-8066</b>	<b>F8-8067</b>	<b>LM-10018S</b>
Ref.Nr.: 1338373080	Ref.Nr.: 1310575080	Ref.Nr.: 0515.T4	Ref.Nr.: 503530	Ref.Nr.: 5038.72	Ref.Nr.: 5038.74	Ref.Nr.: 4018.A5

**Article Description****Article Nr.****Fitting Position****BOXER Box (244)** 04/2002 →

Alternator Freewheel Clutch	2.0 HDi, 2.2 HDi		<b>F5-1046</b>		
Alternator Freewheel Clutch	2.0 HDi, 2.2 HDi		<b>F5-1048</b>		
Top Strut Mounting	2.8 HDi	also for special vehicles;	<b>F8-5353</b>		
Top Strut Mounting	2.8 HDi	also for special vehicles;	<b>F8-5354</b>		
Belt Pulley, crankshaft	2.0 HDi, 2.2 HDi		<b>F8-5636</b>		d=30
Mounting, leaf spring	2.0, 2.0 HDi, 2.2 HDi, 2.8 HDi, 2.8 HDi 4x4		<b>F8-5897</b>		H=46.5; d=16; D=40
Control Arm-/Trailing Arm Bush	2.0, 2.0 HDi, 2.2 HDi, 2.8 HDi, 2.8 HDi 4x4	ch.→17226522; for OE: 1320755080, 1320756080, 3520.N3, 3520.N4, 3521.J3, 3521.J4	<b>F8-6114</b>		
Control Arm-/Trailing Arm Bush	2.0, 2.0 HDi, 2.2 HDi, 2.8 HDi, 2.8 HDi 4x4		<b>F8-6115</b>		H=55; d=25.5; D1=56; D2=45
Top Strut Mounting	2.0, 2.0 HDi, 2.2 HDi, 2.8 HDi, 2.8 HDi 4x4		<b>F8-6306</b>		
Control Arm-/Trailing Arm Bush	2.0, 2.0 HDi, 2.2 HDi, 2.8 HDi, 2.8 HDi 4x4		<b>F8-6452</b>		
Engine Mounting	2.0 HDi	DW10TD	<b>F8-6485</b>		
Engine Mounting	2.0, 2.2 HDi, 2.8 HDi		<b>F8-6485</b>		
Control Arm-/Trailing Arm Bush	2.0, 2.0 HDi, 2.2 HDi, 2.8 HDi, 2.8 HDi 4x4	ch.17226523→; for OE: 3520.N3, 3520.N4, 3521.J3, 3521.J4	<b>F8-6773</b>		
Engine Mounting	2.0 HDi	DW10TD; Orga.09079→	<b>F8-6918</b>		
Engine Mounting	2.2 HDi	Orga.09079→	<b>F8-6918</b>		
Belt Pulley, crankshaft	2.8 HDi, 2.8 HDi 4x4	Number of Ribs: 6	<b>F8-7081</b>		Belt Pulley Ø [mm]=146; W=56
Top Strut Mounting	2.0, 2.0 HDi, 2.2 HDi, 2.8 HDi, 2.8 HDi 4x4		<b>F8-7154</b>		
Top Strut Mounting	2.0, 2.0 HDi, 2.2 HDi, 2.8 HDi, 2.8 HDi 4x4	not for special purpose vehicles;	<b>F8-8066</b>		
Top Strut Mounting	2.0, 2.0 HDi, 2.2 HDi, 2.8 HDi, 2.8 HDi 4x4	not for special purpose vehicles;	<b>F8-8067</b>		

**BOXER Platform/Chassis (244)** 04/2002 →

Dust Cover Kit, shock absorber	2.0 HDi, 2.2 HDi, 2.8 HDi, 2.8 HDi 4x4	[kg]: 1000, 1400	<b>AK-735070</b>		
Alternator Freewheel Clutch	2.0 HDi, 2.2 HDi, 2.8 HDi, 2.8 HDi 4x4		<b>F5-1020</b>		
Alternator Freewheel Clutch	2.0 HDi, 2.2 HDi		<b>F5-1046</b>		
Alternator Freewheel Clutch	2.0 HDi, 2.2 HDi		<b>F5-1048</b>		
Top Strut Mounting	2.2 HDi	also for special vehicles;	<b>F8-5353</b>		
Top Strut Mounting	2.2 HDi	also for special vehicles;	<b>F8-5354</b>		
Belt Pulley, crankshaft	2.0 HDi, 2.2 HDi		<b>F8-5636</b>		d=30
Mounting, leaf spring	2.0 HDi, 2.2 HDi, 2.8 HDi, 2.8 HDi 4x4		<b>F8-5897</b>		H=46.5; d=16; D=40
Control Arm-/Trailing Arm Bush	2.0 HDi, 2.2 HDi, 2.8 HDi, 2.8 HDi 4x4	ch.→17226522; for OE: 1320755080, 1320756080, 3520.N3, 3520.N4, 3521.J3, 3521.J4	<b>F8-6114</b>		
Control Arm-/Trailing Arm Bush	2.0 HDi, 2.2 HDi, 2.8 HDi, 2.8 HDi 4x4		<b>F8-6115</b>		H=55; d=25.5; D1=56; D2=45

<b>AK-735070</b>	<b>F5-1020</b>	<b>F5-1046</b>	<b>F5-1048</b>	<b>F8-5353</b>	<b>F8-5354</b>	<b>F8-5636</b>
Ref.Nr.:	Ref.Nr.: 31771-68D01	Ref.Nr.: 30667687	Ref.Nr.: 77363468	Ref.Nr.: 5038.19	Ref.Nr.: 5038.18	Ref.Nr.: 0515P2
<b>F8-5897</b>	<b>F8-6114</b>	<b>F8-6115</b>	<b>F8-6306</b>	<b>F8-6452</b>	<b>F8-6485</b>	<b>F8-6773</b>
Ref.Nr.: 1304640080	Ref.Nr.: 1320755080-PA	Ref.Nr.: 3523.93	Ref.Nr.: 503547	Ref.Nr.: 3523.93	Ref.Nr.: 1846.66	Ref.Nr.: 1338373080
<b>F8-6918</b>	<b>F8-7081</b>	<b>F8-7154</b>	<b>F8-8066</b>	<b>F8-8067</b>		
Ref.Nr.: 1310575080	Ref.Nr.: 0515.T4	Ref.Nr.: 503530	Ref.Nr.: 5038.72	Ref.Nr.: 5038.74		

Article Description

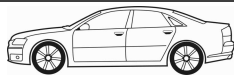

Article Nr.

Fitting Position



<b>BOXER Platform/Chassis (244)</b>			<b>04/2002 →</b>	
Top Strut Mounting	2.0 HDi, 2.2 HDi, 2.8 HDi, 2.8 HDi 4x4		<b>F8-6306</b>	
Control Arm-/Trailing Arm Bush	2.0 HDi, 2.2 HDi, 2.8 HDi, 2.8 HDi 4x4		<b>F8-6452</b>	
Engine Mounting	2.0 HDi	DW 10TD	<b>F8-6485</b>	
Engine Mounting	2.2 HDi, 2.8 HDi		<b>F8-6485</b>	
Control Arm-/Trailing Arm Bush	2.0 HDi, 2.2 HDi, 2.8 HDi, 2.8 HDi 4x4	ch.17226523→; for OE: 3520.N3, 3520.N4, 3521.J3, 3521.J4	<b>F8-6773</b>	
Engine Mounting	2.0 HDi	DW 10TD; Orga.09079→	<b>F8-6918</b>	
Engine Mounting	2.2 HDi	Orga.09079→	<b>F8-6918</b>	
Top Strut Mounting	2.0 HDi, 2.2 HDi, 2.8 HDi, 2.8 HDi 4x4		<b>F8-7154</b>	
Top Strut Mounting	2.0 HDi, 2.2 HDi, 2.8 HDi, 2.8 HDi 4x4	not for special purpose vehicles; ;	<b>F8-8066</b>	
Top Strut Mounting	2.0 HDi, 2.2 HDi, 2.8 HDi, 2.8 HDi 4x4	not for special purpose vehicles; ;	<b>F8-8067</b>	
<b>BOXER Bus</b>			<b>04/2006 →</b>	
Alternator Freewheel Clutch	2.2 HDi 100, 2.2 HDi 110, 2.2 HDi 120, 2.2 HDi 130, 2.2 HDi 150		<b>F5-1125</b>	
Alternator Freewheel Clutch	3.0 HDi 145, 3.0 HDi 160, 3.0 HDi 175		<b>F5-1148</b>	
Top Strut Mounting	2.2 HDi 100, 2.2 HDi 120, 3.0 HDi 160		<b>F8-6610</b>	
Top Strut Mounting	2.2 HDi 100, 2.2 HDi 120, 3.0 HDi 160		<b>F8-6611</b>	
Engine Mounting	2.2 HDi 100, 2.2 HDi 110, 2.2 HDi 120, 2.2 HDi 130, 2.2 HDi 150		<b>F8-6612</b>	
Engine Mounting	2.2 HDi 100, 2.2 HDi 120		<b>F8-6614</b>	
Mounting, manual transmission	3.0 HDi 145, 3.0 HDi 160, 3.0 HDi 175		<b>F8-6712</b>	
Top Strut Mounting	2.2 HDi 100, 2.2 HDi 120, 3.0 HDi 160		<b>F8-7467</b>	
Top Strut Mounting	2.2 HDi 100, 2.2 HDi 120, 3.0 HDi 160		<b>F8-7468</b>	
Mounting, leaf spring	2.2 HDi 100, 2.2 HDi 110, 2.2 HDi 120, 2.2 HDi 130, 2.2 HDi 150, 3.0 HDi 145, 3.0 HDi 160, 3.0 HDi 175		<b>F8-7790</b>	H=43; d=28; D=50
Mounting, leaf spring	2.2 HDi 100, 2.2 HDi 110, 2.2 HDi 120, 2.2 HDi 130, 2.2 HDi 150, 3.0 HDi 145, 3.0 HDi 160, 3.0 HDi 175		<b>F8-7791</b>	d=16,5; L=86,9; D=66,7
<b>BOXER Box</b>			<b>04/2006 →</b>	
Alternator Freewheel Clutch	2.2 HDi 100, 2.2 HDi 110, 2.2 HDi 120, 2.2 HDi 130, 2.2 HDi 150		<b>F5-1125</b>	
Alternator Freewheel Clutch	3.0 D, 3.0 HDi 145, 3.0 HDi 160, 3.0 HDi 175		<b>F5-1148</b>	
Top Strut Mounting	2.2 HDi 100, 2.2 HDi 120, 3.0 D, 3.0 HDi 160		<b>F8-6610</b>	
Top Strut Mounting	2.2 HDi 100, 2.2 HDi 120, 3.0 D, 3.0 HDi 160		<b>F8-6611</b>	
Engine Mounting	2.2 HDi 100, 2.2 HDi 110, 2.2 HDi 120, 2.2 HDi 130, 2.2 HDi 150		<b>F8-6612</b>	
Engine Mounting	2.2 HDi 100, 2.2 HDi 120		<b>F8-6614</b>	
Mounting, manual transmission	3.0 HDi 145, 3.0 HDi 160, 3.0 HDi 175		<b>F8-6712</b>	

<b>F5-1125</b>	<b>F5-1148</b>	<b>F8-6306</b>	<b>F8-6452</b>	<b>F8-6485</b>	<b>F8-6610</b>	<b>F8-6611</b>
Ref.Nr.: 77364082	Ref.Nr.: 77364797	Ref.Nr.: 503547	Ref.Nr.: 3523.93	Ref.Nr.: 1846.66	Ref.Nr.: 5038.A4	Ref.Nr.: 1350788080
<b>F8-6612</b>	<b>F8-6614</b>	<b>F8-6712</b>	<b>F8-6773</b>	<b>F8-6918</b>	<b>F8-7154</b>	<b>F8-7467</b>
Ref.Nr.: 1343631080	Ref.Nr.: 1348993080	Ref.Nr.: 1352888080	Ref.Nr.: 1338373080	Ref.Nr.: 1310575080	Ref.Nr.: 503530	Ref.Nr.: 5038E3
<b>F8-7468</b>	<b>F8-7790</b>	<b>F8-7791</b>	<b>F8-8066</b>	<b>F8-8067</b>		
Ref.Nr.: 503447	Ref.Nr.: 5131.F6	Ref.Nr.: 5102.P8	Ref.Nr.: 5038.72	Ref.Nr.: 5038.74		

**Article Description****Article Nr.****Fitting Position**

<b>BOXER Box</b>				<b>04/2006 →</b>	
Top Strut Mounting	2.2 HDi 100, 2.2 HDi 120, 3.0 HDi 160		<b>F8-7467</b>		
Top Strut Mounting	2.2 HDi 100, 2.2 HDi 120, 3.0 HDi 160		<b>F8-7468</b>		
Mounting, leaf spring	2.2 HDi 100, 2.2 HDi 110, 2.2 HDi 120, 2.2 HDi 130, 2.2 HDi 150, 3.0 D, 3.0 HDi 145, 3.0 HDi 160, 3.0 HDi 175		<b>F8-7790</b>		H=43; d=28; D=50
Mounting, leaf spring	2.2 HDi 100, 2.2 HDi 110, 2.2 HDi 120, 2.2 HDi 130, 2.2 HDi 150, 3.0 D, 3.0 HDi 145, 3.0 HDi 160, 3.0 HDi 175		<b>F8-7791</b>		d=16,5; L=86,9; D=66,7
<b>BOXER Platform/Chassis</b>				<b>04/2006 →</b>	
Alternator Freewheel Clutch	2.2 HDi 100, 2.2 HDi 110, 2.2 HDi 120, 2.2 HDi 130, 2.2 HDi 150		<b>F5-1125</b>		
Alternator Freewheel Clutch	3.0 D, 3.0 HDi 145, 3.0 HDi 160, 3.0 HDi 175		<b>F5-1148</b>		
Top Strut Mounting	2.2 HDi 100, 2.2 HDi 120, 3.0 D, 3.0 HDi 160		<b>F8-6610</b>		
Top Strut Mounting	2.2 HDi 100, 2.2 HDi 120, 3.0 D, 3.0 HDi 160		<b>F8-6611</b>		
Engine Mounting	2.2 HDi 100, 2.2 HDi 110, 2.2 HDi 120, 2.2 HDi 130, 2.2 HDi 150		<b>F8-6612</b>		
Engine Mounting	2.2 HDi 100, 2.2 HDi 120		<b>F8-6614</b>		
Mounting, manual transmission	3.0 HDi 145, 3.0 HDi 160, 3.0 HDi 175		<b>F8-6712</b>		
Top Strut Mounting	2.2 HDi 100, 2.2 HDi 120, 3.0 HDi 160		<b>F8-7467</b>		
Top Strut Mounting	2.2 HDi 100, 2.2 HDi 120, 3.0 HDi 160		<b>F8-7468</b>		
Mounting, leaf spring	All Models		<b>F8-7790</b>		H=43; d=28; D=50
Mounting, leaf spring	All Models		<b>F8-7791</b>		d=16,5; L=86,9; D=66,7
<b>EXPERT (224)</b>				<b>02/1996 → 11/2003</b>	
Dust Cover Kit, shock absorber	1.6, 1.9 D, 1.9 TD, 2.0, 2.0 HDI		<b>AK-735091</b>		
Alternator Freewheel Clutch	2.0 HDI		<b>F5-1020</b>		
Alternator Freewheel Clutch	1.9 D, 2.0 HDI		<b>F5-1046</b>		
Alternator Freewheel Clutch	1.9 D, 2.0 HDI		<b>F5-1048</b>		
Anti-Friction Bearing	All Models		<b>F8-3014</b>		H1=24; H2=46; d1=78; d2=84; D=128
Stabiliser Mounting	1.6, 1.9 D, 1.9 TD, 2.0, 2.0 HDI		<b>F8-5092</b>		d=24
Engine Mounting	1.6, 1.8, 1.9 D, 1.9 TD, 2.0		<b>F8-5569</b>		
Top Strut Mounting	1.6, 1.9 D, 1.9 TD, 2.0, 2.0 HDI		<b>F8-5621</b>		
Top Strut Mounting	1.6, 1.9 D, 1.9 TD, 2.0, 2.0 HDI		<b>F8-5622</b>		
Belt Pulley, crankshaft	2.0 HDI		<b>F8-5636</b>		d=30
Belt Pulley, crankshaft	1.9 D, 1.9 TD	Number of Ribs: 6	<b>F8-5643</b>		Belt Pulley Ø [mm]=156; W=44
Belt Pulley, crankshaft	1.9 D	09/2004 →;  DW8B; Orga.10178 →;	<b>F8-5660</b>		
Belt Pulley, crankshaft	2.0 HDI	12/2002 →; Orga.09520 →	<b>F8-5660</b>		

<b>AK-735091</b>	<b>F5-1020</b>	<b>F5-1046</b>	<b>F5-1048</b>	<b>F5-1125</b>	<b>F5-1148</b>	<b>F8-3014</b>
Ref.Nr.: 503339	Ref.Nr.: 31771-68D01	Ref.Nr.: 30667687	Ref.Nr.: 77363468	Ref.Nr.: 77364082	Ref.Nr.: 77364797	Ref.Nr.: 503545
<b>F8-5092</b>	<b>F8-5569</b>	<b>F8-5621</b>	<b>F8-5622</b>	<b>F8-5636</b>	<b>F8-5643</b>	<b>F8-5660</b>
Ref.Nr.: 1305782080	Ref.Nr.: 9604338880	Ref.Nr.: 1311931080	Ref.Nr.: 503868	Ref.Nr.: 0515P2	Ref.Nr.: 96089 38980	Ref.Nr.: 0515R9
<b>F8-6610</b>	<b>F8-6611</b>	<b>F8-6612</b>	<b>F8-6614</b>	<b>F8-6712</b>	<b>F8-7467</b>	<b>F8-7468</b>
Ref.Nr.: 5038.A4	Ref.Nr.: 1350788080	Ref.Nr.: 1343631080	Ref.Nr.: 1348993080	Ref.Nr.: 1352888080	Ref.Nr.: 5038E3	Ref.Nr.: 503447

Article Description

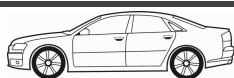

Article Nr.

Fitting Position



<b>EXPERT (224)</b>			<b>02/1996 → 11/2003</b>		
Belt Pulley, crankshaft	2.0 HDI	ch.O09520→	<b>F8-5660</b>		
Mounting, axle beam	1.6, 1.9 D, 1.9 TD, 2.0, 2.0 HDI		<b>F8-5871</b>		H1=60; H2=48; d=12; D=46
Rubber Buffer, suspension	1.6, 1.9 D, 1.9 TD, 2.0, 2.0 HDI		<b>F8-5936</b>		
Control Arm-/Trailing Arm Bush	1.6, 1.8, 1.9 D, 1.9 TD, 2.0, 2.0 HDI		<b>F8-6153</b>		
Control Arm-/Trailing Arm Bush	1.6, 1.8, 1.9 D, 1.9 TD, 2.0, 2.0 HDI		<b>F8-6154</b>		
Control Arm-/Trailing Arm Bush	1.6, 1.8, 1.9 D, 1.9 TD, 2.0, 2.0 HDI		<b>F8-6155</b>		
Engine Mounting	1.6, 1.8, 1.9 D, 1.9 TD, 2.0, 2.0 HDI		<b>F8-6236</b>		H1=53; H2=40; d=10; D=70
Top Strut Mounting	1.6, 1.8, 1.9 D, 1.9 TD, 2.0, 2.0 HDI		<b>F8-6304</b>		
Control Arm-/Trailing Arm Bush	1.6, 1.9 D, 1.9 TD, 2.0, 2.0 HDI		<b>F8-6439</b>		H=50; d=22,85; Inner Thread 1=M12 x 1,25 RHT F; Inner Thread 2=M12 x 1,25 RHT F; L=82
Engine Mounting	2.0	Orga.→09015;	<b>F8-6507</b>		
Engine Mounting	2.0 HDI		<b>F8-6507</b>		
Engine Mounting	2.0 HDI	Orga.→08973	<b>F8-6897</b>		
Top Strut Mounting	1.6, 1.9 D, 1.9 TD, 2.0, 2.0 HDI		<b>F8-7164</b>		
Engine Mounting	2.0 HDI		<b>F8-8149</b>		
Engine Mounting	2.0 HDI		<b>F8-8167</b>		
Bellow, steering	All Models	with clamps	<b>LM-10022S</b>		d1=13; d2=62; L [mm]=210
<b>EXPERT Van (222)</b>			<b>02/1996 → 09/2000</b>		
Dust Cover Kit, shock absorber	1.6, 1.9 D, 1.9 D 70, 1.9 TD, 2.0, 2.0 HDI		<b>AK-735091</b>		
Alternator Freewheel Clutch	2.0 HDI		<b>F5-1020</b>		
Alternator Freewheel Clutch	1.9 D 70, 2.0 HDI		<b>F5-1046</b>		
Alternator Freewheel Clutch	1.9 D 70, 2.0 HDI		<b>F5-1048</b>		
Anti-Friction Bearing	All Models		<b>F8-3014</b>		H1=24; H2=46; d1=78; d2=84; D=128
Stabiliser Mounting	1.6, 1.9 D, 1.9 TD, 2.0 HDI		<b>F8-5092</b>		d=24
Engine Mounting	1.6, 1.8, 1.9 D, 1.9 D 70, 1.9 TD, 2.0		<b>F8-5569</b>		
Top Strut Mounting	1.6, 1.9 D, 1.9 D 70, 1.9 TD, 2.0, 2.0 HDI		<b>F8-5621</b>		
Top Strut Mounting	1.6, 1.9 D, 1.9 D 70, 1.9 TD, 2.0, 2.0 HDI		<b>F8-5622</b>		
Belt Pulley, crankshaft	1.9 D 70	DW8B	<b>F8-5636</b>		d=30
Belt Pulley, crankshaft	2.0 HDI		<b>F8-5636</b>		d=30
Belt Pulley, crankshaft	1.9 D, 1.9 TD	Number of Ribs: 6	<b>F8-5643</b>		Belt Pulley Ø [mm]=156; W=44
Belt Pulley, crankshaft	1.9 D 70	ch.→O09894;	<b>F8-5659</b>		
Belt Pulley, crankshaft	1.9 D 70	DW8B; Orga.10178→	<b>F8-5660</b>		

<b>AK-735091</b>	<b>F5-1020</b>	<b>F5-1046</b>	<b>F5-1048</b>	<b>F8-3014</b>	<b>F8-5092</b>	<b>F8-5569</b>
Ref.Nr.: 503339	Ref.Nr.: 31771-68D01	Ref.Nr.: 30667687	Ref.Nr.: 77363468	Ref.Nr.: 503545	Ref.Nr.: 1305782080	Ref.Nr.: 9604338880
<b>F8-5621</b>	<b>F8-5622</b>	<b>F8-5636</b>	<b>F8-5643</b>	<b>F8-5659</b>	<b>F8-5660</b>	<b>F8-5871</b>
Ref.Nr.: 1311931080	Ref.Nr.: 503868	Ref.Nr.: 0515P2	Ref.Nr.: 96089 38980	Ref.Nr.: 0515Q6	Ref.Nr.: 0515R9	Ref.Nr.: 515261
<b>F8-5936</b>	<b>F8-6153</b>	<b>F8-6154</b>	<b>F8-6155</b>	<b>F8-6236</b>	<b>F8-6304</b>	<b>F8-6439</b>
Ref.Nr.: 5033.39	Ref.Nr.: 3520.G9S1	Ref.Nr.: 3521.C9S	Ref.Nr.: 1316735080S	Ref.Nr.: 1809.21	Ref.Nr.: 1311930080	Ref.Nr.: 1312317080



**Article Description****Article Nr.****Fitting Position**

<b>EXPERT Van (222)</b>			<b>02/1996 → 09/2000</b>		
Belt Pulley, crankshaft	2.0 HDI	12/2002 →; Orga.09520→	<b>F8-5660</b>		
Belt Pulley, crankshaft	2.0 HDI	ch.O09520→	<b>F8-5660</b>		
Mounting, axle beam	1.6, 1.9 D, 1.9 TD, 2.0, 2.0 HDI		<b>F8-5871</b>		H1=60; H2=48; d=12; D=46
Rubber Buffer, suspension	1.6, 1.9 D, 1.9 D 70, 1.9 TD, 2.0 HDI		<b>F8-5936</b>		
Control Arm-/Trailing Arm Bush	All Models		<b>F8-6153</b>		
Control Arm-/Trailing Arm Bush	All Models		<b>F8-6154</b>		
Control Arm-/Trailing Arm Bush	All Models		<b>F8-6155</b>		
Engine Mounting	All Models		<b>F8-6236</b>		H1=53; H2=40; d=10; D=70
Top Strut Mounting	All Models		<b>F8-6304</b>		
Control Arm-/Trailing Arm Bush	1.6, 1.9 D, 1.9 D 70, 1.9 TD, 2.0, 2.0 HDI		<b>F8-6439</b>		H=50; d=22.85; Inner Thread 1=M12 x 1,25 RHT F; Inner Thread 2=M12 x 1,25 RHT F; L=82
Engine Mounting	2.0, 2.0 HDI		<b>F8-6507</b>		
Engine Mounting	2.0 HDI	Orga.→08973	<b>F8-6897</b>		
Top Strut Mounting	1.6, 1.9 D, 1.9 TD, 2.0 HDI		<b>F8-7164</b>		
Belt Pulley, crankshaft	1.9 D 70	Orga.09895→;	<b>F8-7862</b>		
Engine Mounting	2.0 HDI		<b>F8-8149</b>		
Engine Mounting	1.9 D 70, 2.0 HDI		<b>F8-8167</b>		
Bellow, steering	All Models	with clamps	<b>LM-10022S</b>		d1=13; d2=62; L [mm]=210
<b>EXPERT Platform/Chassis (223)</b>			<b>02/1996 → 10/2006</b>		
Dust Cover Kit, shock absorber	1.6, 1.9 D, 1.9 TD		<b>AK-735091</b>		
Alternator Freewheel Clutch	1.9 D, 2.0 HDI		<b>F5-1046</b>		
Alternator Freewheel Clutch	1.9 D, 2.0 HDI		<b>F5-1048</b>		
Anti-Friction Bearing	All Models		<b>F8-3014</b>		H1=24; H2=46; d1=78; d2=84; D=128
Stabiliser Mounting	1.6, 1.9 D, 1.9 TD		<b>F8-5092</b>		d=24
Engine Mounting	1.6, 1.9 D, 1.9 TD		<b>F8-5569</b>		
Top Strut Mounting	1.6, 1.9 D, 1.9 TD		<b>F8-5621</b>		
Top Strut Mounting	1.6, 1.9 D, 1.9 TD		<b>F8-5622</b>		
Belt Pulley, crankshaft	2.0 HDI		<b>F8-5636</b>		d=30
Belt Pulley, crankshaft	1.9 D, 1.9 TD	Number of Ribs: 6	<b>F8-5643</b>		Belt Pulley Ø [mm]=156; W=44
Belt Pulley, crankshaft	2.0 HDI	12/2002 →; Orga.09519, 09520→	<b>F8-5660</b>		
Mounting, axle beam	1.6, 1.9 D, 1.9 TD		<b>F8-5871</b>		H1=60; H2=48; d=12; D=46
Rubber Buffer, suspension	1.6, 1.9 D, 1.9 TD		<b>F8-5936</b>		

<b>AK-735091</b>	<b>F5-1046</b>	<b>F5-1048</b>	<b>F8-3014</b>	<b>F8-5092</b>	<b>F8-5569</b>	<b>F8-5621</b>
Ref.Nr.: 503339	Ref.Nr.: 30667687	Ref.Nr.: 77363468	Ref.Nr.: 503545	Ref.Nr.: 1305782080	Ref.Nr.: 9604338880	Ref.Nr.: 1311931080
<b>F8-5622</b>	<b>F8-5636</b>	<b>F8-5643</b>	<b>F8-5660</b>	<b>F8-5871</b>	<b>F8-5936</b>	<b>F8-6153</b>
Ref.Nr.: 503868	Ref.Nr.: 0515P2	Ref.Nr.: 96089 38980	Ref.Nr.: 0515R9	Ref.Nr.: 515261	Ref.Nr.: 5033.39	Ref.Nr.: 3520.G9S1
<b>F8-6154</b>	<b>F8-6155</b>	<b>F8-6236</b>	<b>F8-6304</b>	<b>F8-6439</b>	<b>F8-6507</b>	<b>F8-6897</b>
Ref.Nr.: 3521.C9S	Ref.Nr.: 1316735080S	Ref.Nr.: 1809.21	Ref.Nr.: 1311930080	Ref.Nr.: 1312317080	Ref.Nr.: 1827.16	Ref.Nr.: 1827.33

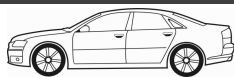
**Article Description**

**Article Nr.**
**Fitting Position**

**EXPERT Platform/Chassis (223) 02/1996 → 10/2006**

Control Arm-/Trailing Arm Bush	1.6, 1.9 D, 1.9 TD, 2.0 HDi		<b>F8-6153</b>		
Control Arm-/Trailing Arm Bush	1.6, 1.9 D, 1.9 TD, 2.0 HDi		<b>F8-6154</b>		
Control Arm-/Trailing Arm Bush	1.6, 1.9 D, 1.9 TD, 2.0 HDi		<b>F8-6155</b>		
Engine Mounting	1.6, 1.9 D, 1.9 TD, 2.0 HDi		<b>F8-6236</b>		H1=53; H2=40; d=10; D=70
Top Strut Mounting	1.6, 1.9 D, 1.9 TD, 2.0 HDi		<b>F8-6304</b>		
Control Arm-/Trailing Arm Bush	1.9 D, 1.9 TD		<b>F8-6439</b>		H=50; d=22.85; Inner Thread 1=M12 x 1,25 RHT F; Inner Thread 2=M12 x 1,25 RHT F; L=82
Engine Mounting	2.0 HDi		<b>F8-6507</b>		
Top Strut Mounting	1.6, 1.9 D, 1.9 TD		<b>F8-7164</b>		
Engine Mounting	2.0 HDi		<b>F8-8149</b>		
Bellow, steering	All Models	with clamps	<b>LM-10022S</b>		d1=13; d2=62; L [mm]=210

**EXPERT Box (VF3A\_, VF3U\_, VF3X\_) 01/2007 →**

Alternator Freewheel Clutch	1.6 HDi 90, 2.0 HDi 100, 2.0 HDi 120, 2.0 HDi 130, 2.0 HDi 140		<b>F5-1046</b>		
Alternator Freewheel Clutch	1.6 HDi 90, 2.0 HDi 120, 2.0 HDi 140		<b>F5-1048</b>		
Anti-Friction Bearing	1.6 HDi 90, 2.0 16V, 2.0 HDi 120, 2.0 HDi 140, 2.0 HDi 165		<b>F8-3014</b>		H1=24; H2=46; d1=78; d2=84; D=128
Engine Mounting	2.0 HDi 120, 2.0 HDi 140		<b>F8-5375</b>		H=34; d=12; D=30
Engine Mounting	1.6 HDi 90, 2.0 16V, 2.0 HDi 120, 2.0 HDi 140		<b>F8-5569</b>		
Engine Mounting	2.0 16V, 2.0 HDi 120		<b>F8-6236</b>		H1=53; H2=40; d=10; D=70
Engine Mounting	2.0 HDi 120, 2.0 HDi 140		<b>F8-6507</b>		
Engine Mounting	2.0 HDi 120, 2.0 HDi 140		<b>F8-8149</b>		
Engine Mounting	2.0 16V		<b>F8-8169</b>		

**EXPERT Platform/Chassis 01/2007 →**

Alternator Freewheel Clutch	All Models		<b>F5-1046</b>		
Alternator Freewheel Clutch	All Models		<b>F5-1048</b>		
Anti-Friction Bearing	All Models		<b>F8-3014</b>		H1=24; H2=46; d1=78; d2=84; D=128
Engine Mounting	2.0 HDi 120, 2.0 HDi 140		<b>F8-5375</b>		H=34; d=12; D=30
Engine Mounting	All Models		<b>F8-5569</b>		
Engine Mounting	2.0 HDi 120, 2.0 HDi 140		<b>F8-6507</b>		
Engine Mounting	2.0 HDi 120, 2.0 HDi 140		<b>F8-8149</b>		

<b>F5-1046</b>	<b>F5-1048</b>	<b>F8-3014</b>	<b>F8-5375</b>	<b>F8-5569</b>	<b>F8-6153</b>	<b>F8-6154</b>
Ref.Nr.: 30667687	Ref.Nr.: 77363468	Ref.Nr.: 503545	Ref.Nr.: 180906	Ref.Nr.: 9604338880	Ref.Nr.: 3520.G9S1	Ref.Nr.: 3521.C9S
<b>F8-6155</b>	<b>F8-6236</b>	<b>F8-6304</b>	<b>F8-6439</b>	<b>F8-6507</b>	<b>F8-7164</b>	<b>F8-8149</b>
Ref.Nr.: 1316735080S	Ref.Nr.: 1809.21	Ref.Nr.: 1311930080	Ref.Nr.: 1312317080	Ref.Nr.: 1827.16	Ref.Nr.: 503555	Ref.Nr.: 1844.93
<b>F8-8169</b>	<b>LM-10022S</b>					
Ref.Nr.: 180669	Ref.Nr.: 4066.41					

**Article Description****Article Nr.****Fitting Position**

<b>EXPERT Tepee (VF3V_)</b>				<b>01/2007 →</b>	
Alternator Freewheel Clutch	2.0 HDi 100, 2.0 HDi 120, 2.0 HDi 120 4x4, 2.0 HDi 130, 2.0 HDi 140		<b>F5-1046</b>		
Alternator Freewheel Clutch	1.6 HDi 90, 2.0 HDi 120, 2.0 HDi 120 4x4, 2.0 HDi 140		<b>F5-1048</b>		
Anti-Friction Bearing	1.6 HDi 90, 2.0 16V, 2.0 HDi 120, 2.0 HDi 120 4x4, 2.0 HDi 140, 2.0 HDi 165		<b>F8-3014</b>		H1=24; H2=46; d1=78; d2=84; D=128
Engine Mounting	2.0 HDi 120, 2.0 HDi 140		<b>F8-5375</b>		H=34; d=12; D=30
Engine Mounting	1.6 HDi 90, 2.0 16V, 2.0 HDi 120, 2.0 HDi 140		<b>F8-5569</b>		
Engine Mounting	2.0 16V, 2.0 HDi 120		<b>F8-6236</b>		H1=53; H2=40; d=10; D=70
Engine Mounting	2.0 HDi 120, 2.0 HDi 140		<b>F8-6507</b>		
Engine Mounting	2.0 HDi 120, 2.0 HDi 120 4x4, 2.0 HDi 140		<b>F8-8149</b>		
Engine Mounting	2.0 16V		<b>F8-8169</b>		
<b>J5 Bus (280P)</b>				<b>09/1981 → 09/1990</b>	
Dust Cover Kit, shock absorber	2.0, 2.5 D	ch.0244301→	<b>AK-735070</b>		
Anti-Friction Bearing	2.0, 2.5 D		<b>F8-3013</b>		H=7; d=49; D=71
Tie Bar Bush	2.0, 2.5 D		<b>F8-5084</b>		H=24.5; H1=20.5; d=22; D=48
Top Strut Mounting	All Models		<b>F8-5612</b>		
Mounting, leaf spring	2.5 D		<b>F8-5870</b>		H=72; d=16; D=38
Engine Mounting	2.0, 2.5 D		<b>F8-6509</b>		
Engine Mounting	2.5 D	ch.S221892→	<b>F8-6902</b>		
Engine Mounting	2.5 D	ch.→S341863	<b>F8-6903</b>		
<b>J5 Box (280L)</b>				<b>09/1981 → 08/1990</b>	
Dust Cover Kit, shock absorber	1.8	ch.0244301→;  [kg]: 1000, 1400	<b>AK-735070</b>		
Anti-Friction Bearing	1.8		<b>F8-3013</b>		H=7; d=49; D=71
Tie Bar Bush	1.8		<b>F8-5084</b>		H=24.5; H1=20.5; d=22; D=48
Top Strut Mounting	1.8, 1.9 D, 2.0, 2.5 D, 2.5 DT		<b>F8-5612</b>		
Belt Pulley, crankshaft	1.9 D		<b>F8-5646</b>		
Mounting, leaf spring	1.8		<b>F8-5870</b>		H=72; d=16; D=38
Engine Mounting	1.8, 1.9 D, 2.0, 2.5 D, 2.5 DT		<b>F8-6509</b>		
<b>J5 Platform/Chassis (280L)</b>				<b>09/1981 → 09/1990</b>	
Dust Cover Kit, shock absorber	2.0, 2.5 D	[kg]: 1000, 1400	<b>AK-735070</b>		
Anti-Friction Bearing	2.0, 2.5 D		<b>F8-3013</b>		H=7; d=49; D=71
Tie Bar Bush	2.0, 2.5 D		<b>F8-5084</b>		H=24.5; H1=20.5; d=22; D=48
Top Strut Mounting	All Models		<b>F8-5612</b>		
Mounting, leaf spring	2.0, 2.5 D		<b>F8-5870</b>		H=72; d=16; D=38
Engine Mounting	1.8, 2.0, 2.5 DT		<b>F8-6509</b>		

<b>AK-735070</b>	<b>F5-1046</b>	<b>F5-1048</b>	<b>F8-3013</b>	<b>F8-3014</b>	<b>F8-5084</b>	<b>F8-5375</b>
Ref.Nr.:	Ref.Nr.: 30667687	Ref.Nr.: 77363468	Ref.Nr.: 503517	Ref.Nr.: 503545	Ref.Nr.: 3561.08	Ref.Nr.: 180906
<b>F8-5569</b>	<b>F8-5612</b>	<b>F8-5646</b>	<b>F8-5870</b>	<b>F8-6236</b>	<b>F8-6507</b>	<b>F8-6509</b>
Ref.Nr.: 9604338880	Ref.Nr.: 04466980	Ref.Nr.: 0515K9	Ref.Nr.: 04333710	Ref.Nr.: 1809.21	Ref.Nr.: 1827.16	Ref.Nr.: 1843.61
<b>F8-6902</b>	<b>F8-6903</b>	<b>F8-8149</b>	<b>F8-8169</b>			
Ref.Nr.: 7550024	Ref.Nr.: 5934176	Ref.Nr.: 1844.93	Ref.Nr.: 180669			

Article Description



Article Nr.

Fitting Position



<b>J5 Platform/Chassis (280L)</b>				<b>09/1981 → 09/1990</b>	
Engine Mounting	2.5 D	ch.S221892→	<b>F8-6902</b>		
Engine Mounting	2.5 D	ch.→S341863	<b>F8-6903</b>		
<b>J5 Bus (290P)</b>				<b>10/1990 → 02/1994</b>	
Dust Cover Kit, shock absorber	All Models		<b>AK-735070</b>		
Anti-Friction Bearing	All Models		<b>F8-3013</b>		H=7; d=49; D=71
Tie Bar Bush	1.9 D, 2.0, 2.5 D, 2.5 TD		<b>F8-5084</b>		H=24.5; H1=20.5; d=22; D=48
Top Strut Mounting	All Models		<b>F8-5612</b>		
Belt Pulley, crankshaft	1.9 D		<b>F8-5646</b>		
Mounting, leaf spring	1.9 D, 2.5 TD		<b>F8-5870</b>		H=72; d=16; D=38
Engine Mounting	1.9 D, 2.0, 2.5 D, 2.5 TD		<b>F8-6496</b>		
<b>J5 Box (290L)</b>				<b>09/1990 → 03/1994</b>	
Dust Cover Kit, shock absorber	1.9 D, 2.5 D 4x4, 2.5 TD 4x4	[kg]: 1000, 1400	<b>AK-735070</b>		
Anti-Friction Bearing	1.9 D, 2.5 D 4x4, 2.5 TD 4x4		<b>F8-3013</b>		H=7; d=49; D=71
Tie Bar Bush	1.9 D, 2.5 D 4x4, 2.5 TD 4x4		<b>F8-5084</b>		H=24.5; H1=20.5; d=22; D=48
Top Strut Mounting	All Models		<b>F8-5612</b>		
Belt Pulley, crankshaft	1.9 D		<b>F8-5646</b>		
Mounting, leaf spring	1.9 D, 2.5 D 4x4, 2.5 TD 4x4		<b>F8-5870</b>		H=72; d=16; D=38
Engine Mounting	1.9 D, 2.5 TD 4x4		<b>F8-6496</b>		
Engine Mounting	1.9 D		<b>F8-6509</b>		
<b>J5 Platform/Chassis (290L)</b>				<b>09/1990 → 02/1994</b>	
Dust Cover Kit, shock absorber	1.9 D, 2.0, 2.5 D, 2.5 D 4x4, 2.5 TD, 2.5 TD 4x4	[kg]: 1000, 1400	<b>AK-735070</b>		
Anti-Friction Bearing	1.9 D, 2.0, 2.5 D, 2.5 D 4x4, 2.5 TD, 2.5 TD 4x4		<b>F8-3013</b>		H=7; d=49; D=71
Tie Bar Bush	1.9 D, 2.0, 2.5 D, 2.5 D 4x4, 2.5 TD		<b>F8-5084</b>		H=24.5; H1=20.5; d=22; D=48
Top Strut Mounting	All Models		<b>F8-5612</b>		
Belt Pulley, crankshaft	1.9 D		<b>F8-5646</b>		
Mounting, leaf spring	1.9 D, 2.5 D, 2.5 D 4x4, 2.5 TD		<b>F8-5870</b>		H=72; d=16; D=38
Engine Mounting	1.9 D, 2.0, 2.5 D, 2.5 TD		<b>F8-6496</b>		
Engine Mounting	1.9 D		<b>F8-6509</b>		
<b>J7 Bus</b>				<b>08/1968 → 03/1980</b>	
Control Arm-/Trailing Arm Bush	All Models		<b>F8-6815</b>		
<b>J7 Box</b>				<b>08/1968 → 03/1980</b>	
Control Arm-/Trailing Arm Bush	All Models		<b>F8-6815</b>		

<b>AK-735070</b>	<b>F8-3013</b>	<b>F8-5084</b>	<b>F8-5612</b>	<b>F8-5646</b>	<b>F8-5870</b>	<b>F8-6496</b>
Ref.Nr.:	Ref.Nr.: 503517	Ref.Nr.: 3561.08	Ref.Nr.: 04466980	Ref.Nr.: 0515K9	Ref.Nr.: 04333710	Ref.Nr.: 1844.41
<b>F8-6509</b>	<b>F8-6815</b>	<b>F8-6902</b>	<b>F8-6903</b>			
Ref.Nr.: 1843.61	Ref.Nr.: 3561.05	Ref.Nr.: 7550024	Ref.Nr.: 5934176			

**Article Description****Article Nr.****Fitting Position**

<b>J7 Platform/Chassis</b>			<b>08/1968 → 03/1980</b>	
Control Arm-/Trailing Arm Bush	All Models		<b>F8-6815</b>	
<b>J9 Bus</b>			<b>03/1980 → 06/1987</b>	
Control Arm-/Trailing Arm Bush	All Models		<b>F8-6815</b>	
<b>J9 Box</b>			<b>03/1980 → 06/1987</b>	
Control Arm-/Trailing Arm Bush	All Models		<b>F8-6815</b>	
<b>J9 Platform/Chassis</b>			<b>03/1980 → 06/1987</b>	
Control Arm-/Trailing Arm Bush	All Models		<b>F8-6815</b>	
<b>PARTNER Combispace (5F)</b>			<b>05/1996 → 10/2006</b>	
Dust Cover Kit, shock absorber	1.1, 1.4, 1.6 16V, 1.6 HDi 75, 1.6 HDi 90, 1.8, 1.9 D, 2.0 HDi		<b>AK-735010</b>	⊕ ⊕
Alternator Freewheel Clutch	1.6 HDi 75, 1.6 HDi 90, 1.9 D, 1.9 D 4x4, 2.0 HDi, 2.0 HDi 4x4		<b>F5-1046</b>	
Alternator Freewheel Clutch	1.6 HDi 75, 1.6 HDi 90, 1.9 D, 1.9 D 4x4, 2.0 HDi, 2.0 HDi 4x4		<b>F5-1048</b>	
Anti-Friction Bearing	1.1, 1.4, 1.6 16V, 1.6 HDi 75, 1.6 HDi 90, 1.8, 1.9 D, 2.0 HDi, 2.0 HDi 4x4, Electric		<b>F8-3012</b>	⊕ ⊕ H=20; d=66; D=100
Stabiliser Mounting	1.1, 1.4, 1.6 16V, 1.8, 1.9 D		<b>F8-5213</b>	D=21; d=21
Stabiliser Mounting	1.9 D, 2.0 HDi		<b>F8-5213</b>	d=21
Control Arm-/Trailing Arm Bush	1.1, 1.4, 1.6 16V, 1.8, 1.9 D		<b>F8-5248</b>	⊕ ⊕
Control Arm-/Trailing Arm Bush	1.1, 1.4, 1.6 16V, 1.6 HDi 75, 1.6 HDi 90, 1.8, 1.9 D		<b>F8-5355</b>	↓
Bellow, driveshaft	1.1, 1.4		<b>F8-5356</b>	⊕ ⊕ D1=72; D219; L=172
Engine Mounting	1.9 D, 2.0 HDi, 2.0 HDi 4x4		<b>F8-5357</b>	⊕ ↓
Engine Mounting	1.8		<b>F8-5358</b>	⊕
Control Arm-/Trailing Arm Bush	2.0 HDi, 2.0 HDi 4x4		<b>F8-5361</b>	⊕ ⊕
Engine Mounting	1.1, 1.4, 2.0 HDi 4x4		<b>F8-5375</b>	H=34; d=12; D=30
Top Strut Mounting	1.1, 1.4, 1.6 16V, 1.8, 1.9 D, 2.0 HDi		<b>F8-5516</b>	⊕ ⊕
Top Strut Mounting	1.1, 1.4, 1.6 16V, 1.8, 1.9 D, 2.0 HDi		<b>F8-5517</b>	⊕ ⊕
Engine Mounting	1.1, 1.4, 1.8, 2.0 HDi		<b>F8-5568</b>	⊕
Engine Mounting	1.9 D	DW8	<b>F8-5568</b>	⊕
Belt Pulley, crankshaft	1.9 D, 2.0 HDi		<b>F8-5636</b>	d=30
Belt Pulley, crankshaft	2.0 HDi 4x4	Orga. → 10179	<b>F8-5636</b>	d=30
Belt Pulley, crankshaft	1.9 D	Number of Ribs: 6	<b>F8-5643</b>	Belt Pulley Ø [mm]=156; W=44

<b>AK-735010</b>	<b>F5-1046</b>	<b>F5-1048</b>	<b>F8-3012</b>	<b>F8-5213</b>	<b>F8-5248</b>	<b>F8-5355</b>
Ref.Nr.:	Ref.Nr.: 30667687	Ref.Nr.: 77363468	Ref.Nr.: 503527	Ref.Nr.: 5094.65	Ref.Nr.: 3523.59	Ref.Nr.: 3520.H5S1
<b>F8-5356</b>	<b>F8-5357</b>	<b>F8-5358</b>	<b>F8-5361</b>	<b>F8-5375</b>	<b>F8-5516</b>	<b>F8-5517</b>
Ref.Nr.: 328769	Ref.Nr.: 1844.47	Ref.Nr.: 184373	Ref.Nr.: 3523.83	Ref.Nr.: 180906	Ref.Nr.: 503824	Ref.Nr.: 5038.23
<b>F8-5568</b>	<b>F8-5636</b>	<b>F8-5643</b>	<b>F8-5659</b>	<b>F8-6815</b>		
Ref.Nr.: 184425	Ref.Nr.: 0515P2	Ref.Nr.: 96089 38980	Ref.Nr.: 0515Q6	Ref.Nr.: 3561.05		

Article Description



Article Nr.

Fitting Position



<b>PARTNER Combispac (5F)</b>			<b>05/1996 → 10/2006</b>		
Belt Pulley, crankshaft	1.9 D		<b>F8-5659</b>		
Belt Pulley, crankshaft	1.9 D	DW8B; Orga.10178→	<b>F8-5660</b>		
Belt Pulley, crankshaft	2.0 HDi, 2.0 HDi 4x4	Orga.10180→	<b>F8-5660</b>		
Mounting, axle beam	1.1, 1.4, 1.6 16V, 1.8, 1.9 D, 2.0 HDi		<b>F8-5852</b>	⊕ ⊕	H=30; D=11.5
Rubber Buffer, suspension	1.1	TU1JP	<b>F8-5935</b>	⊕ ⊕ ⊕	H=109
Rubber Buffer, suspension	1.4	TU32	<b>F8-5935</b>	⊕ ⊕ ⊕	H=109
Rubber Buffer, suspension	1.4, 1.6 16V, 1.6 HDi 90, 1.8, 1.9 D, 1.9 D 4x4, 2.0 HDi, 2.0 HDi 4x4, Electric		<b>F8-5935</b>	⊕ ⊕ ⊕	H=109
Stabiliser Mounting	1.1, 1.4, 1.6 16V, 1.6 HDi 90, 1.8, 1.9 D, 2.0 HDi, 2.0 HDi 4x4		<b>F8-6128</b>		d=22
Mounting, axle beam	1.1, 1.4, 1.6 16V, 1.8, 1.9 D, 2.0 HDi		<b>F8-6176</b>	⊕ ⊕ ⊕	
Engine Mounting	1.8, 1.9 D, 2.0 HDi, 2.0 HDi 4x4		<b>F8-6236</b>	⊕	H1=53; H2=40; d=10; D=70
Engine Mounting	1.8, 1.9 D, 2.0 HDi, 2.0 HDi 4x4		<b>F8-6237</b>		
Repair Kit, wheel suspension	1.1, 1.4, 1.6 16V, 1.6 HDi 75, 1.6 HDi 90, 1.8, 1.9 D, 2.0 HDi, 2.0 HDi 4x4		<b>F8-6276</b>		
Top Strut Mounting	1.1, 1.4, 1.6 16V, 1.8, 1.9 D, 2.0 HDi	⊕	<b>F8-6296</b>		
Top Strut Mounting	1.1, 1.4, 1.6 16V, 1.8, 1.9 D, 2.0 HDi	⊕	<b>F8-6297</b>		
Belt Pulley, crankshaft	1.4, 1.6 16V	Number of Ribs: 5; Parameter: 6PK	<b>F8-6394</b>		H=25; d=44.05; Mounting points diam.[mm]=9; D=148; D1=142.9
Engine Mounting	1.9 D	11/2002 →;  DW8B	<b>F8-6486</b>	⊕	
Engine Mounting	2.0 HDi	11/2002 →	<b>F8-6486</b>	⊕	
Engine Mounting	2.0 HDi 4x4		<b>F8-6486</b>	⊕	
Engine Mounting	1.1	TU1JP	<b>F8-6487</b>	⊕	
Engine Mounting	1.4		<b>F8-6487</b>	⊕	
Engine Mounting	1.6 16V		<b>F8-6497</b>	⊕	
Engine Mounting	1.6 16V, 1.6 HDi 90, 1.8, 1.9 D, 1.9 D 4x4, 2.0 HDi, 2.0 HDi 4x4		<b>F8-6500</b>	⊕	
Engine Mounting	1.9 D	DW8B	<b>F8-6500</b>	⊕	
Mounting, automatic transmission	1.1	TU1JP	<b>F8-6505</b>	⊕	
Mounting, automatic transmission	1.4		<b>F8-6505</b>	⊕	
Rubber Buffer, suspension	1.1, 1.4, 1.6 16V, 1.8, 1.9 D, 2.0 HDi	Orga.→09799	<b>F8-7589</b>	⊕ ⊕ ⊕	H=81
Rubber Buffer, suspension	1.1, 1.4, 1.6 16V, 1.6 HDi 90, 1.8, 1.9 D, 2.0 HDi, 2.0 HDi 4x4	Orga.09800→	<b>F8-7590</b>	⊕ ⊕ ⊕	H=94
Belt Pulley, crankshaft	1.6 16V	Number of Ribs: 4; Parameter: 5PK	<b>F8-7643</b>		D=128
Belt Pulley, crankshaft	1.9 D	DW8; Orga.09895→;	<b>F8-7862</b>		
Belt Pulley, crankshaft	1.9 D	DW8B; Orga.09905→;	<b>F8-7862</b>		

<b>F8-5659</b>	<b>F8-5660</b>	<b>F8-5852</b>	<b>F8-5935</b>	<b>F8-6128</b>	<b>F8-6176</b>	<b>F8-6236</b>
Ref.Nr.: 0515Q6	Ref.Nr.: 0515R9	Ref.Nr.: 5131.47	Ref.Nr.: 5033.40	Ref.Nr.: 5094.77	Ref.Nr.: 515262	Ref.Nr.: 1809.21
<b>F8-6237</b>	<b>F8-6276</b>	<b>F8-6296</b>	<b>F8-6297</b>	<b>F8-6394</b>	<b>F8-6486</b>	<b>F8-6487</b>
Ref.Nr.: 1809.22	Ref.Nr.: 9612314280	Ref.Nr.: 503824	Ref.Nr.: 503527	Ref.Nr.: 0515.R8	Ref.Nr.: 1844.77	Ref.Nr.: 184472
<b>F8-6497</b>	<b>F8-6500</b>	<b>F8-6505</b>	<b>F8-7589</b>	<b>F8-7590</b>	<b>F8-7643</b>	<b>F8-7862</b>
Ref.Nr.: 1844.75	Ref.Nr.: 1844.36	Ref.Nr.: 1844.51	Ref.Nr.: 9621916980	Ref.Nr.: 5166.73	Ref.Nr.: 0515.J3	Ref.Nr.: 0515 R5

**Article Description****Article Nr.****Fitting Position**

<b>PARTNER Combispacer (5F)</b>				<b>05/1996 → 10/2006</b>	
Engine Mounting	1.6 HDi 90		<b>F8-8184</b>		
Repair Kit, wheel suspension	All Models		<b>G8-276-5017</b>		H=197; d=34; D=50,17
Repair Kit, wheel suspension	All Models		<b>G8-276-5020</b>		H=197; d=34; D=50,2
Bellow, steering	1.1, 1.4, 1.6 16V, 1.6 HDi 75, 1.6 HDi 90, 1.8, 1.9 D, 1.9 D 4x4, 2.0 HDi, 2.0 HDi 4x4, Electric	; with clamps;	<b>LM-10004S</b>		d1=10; d2=40; L [mm]=175
Bellow, steering	1.1, 1.4, 1.6 16V, 1.6 HDi 75, 1.6 HDi 90, 1.8, 1.9 D, 1.9 D 4x4, 2.0 HDi, 2.0 HDi 4x4, Electric	; with clamps;	<b>LM-10004S</b>		d1=10; d2=40; L [mm]=175
Bellow, steering	1.1	TU1JP; with clamps;	<b>LM-10039S</b>		d1=40; d2=40; L [mm]=115
Bellow, steering	1.4	TU32; with clamps;	<b>LM-10039S</b>		d1=40; d2=40; L [mm]=115
Bellow, steering	1.4	TU3JP; with clamps;	<b>LM-10039S</b>		d1=40; d2=40; L [mm]=115
Bellow, steering	1.6 16V, 1.8, 1.9 D, 2.0 HDi	with clamps;	<b>LM-10039S</b>		d1=40; d2=40; L [mm]=115
<b>PARTNER Van (5)</b>				<b>04/1996 → 10/2006</b>	
Dust Cover Kit, shock absorber	1.1, 1.4, 1.4 BiFuel, 1.6 HDi 75, 1.6 HDi 90, 1.8 D, 1.9 D, 1.9 D 4x4, 2.0 HDi, 2.0 HDi 4x4		<b>AK-735010</b>		
Alternator Freewheel Clutch	1.6 HDi 75, 1.6 HDi 90, 1.9 D, 1.9 D 4x4, 2.0 HDi, 2.0 HDi 4x4		<b>F5-1046</b>		
Alternator Freewheel Clutch	1.6 HDi 75, 1.6 HDi 90, 1.9 D, 1.9 D 4x4, 2.0 HDi, 2.0 HDi 4x4		<b>F5-1048</b>		
Anti-Friction Bearing	1.1, 1.4, 1.4 BiFuel, 1.6, 1.6 HDi 75, 1.6 HDi 90, 1.8 D, 1.9 D, 1.9 D 4x4, 2.0 HDi, 2.0 HDi 4x4, Electric		<b>F8-3012</b>		H=20; d=66; D=100
Stabiliser Mounting	1.1, 1.4, 1.8 D, 1.9 D, 2.0 HDi		<b>F8-5213</b>		D=21; d=21
Control Arm-/Trailing Arm Bush	1.1, 1.4, 1.8 D, 1.9 D		<b>F8-5248</b>		
Control Arm-/Trailing Arm Bush	1.1, 1.4, 1.4 BiFuel, 1.6 HDi 75, 1.8 D, 1.9 D, 1.9 D 4x4		<b>F8-5355</b>		
Bellow, driveshaft	1.1, 1.4		<b>F8-5356</b>		D1=72; D219; L=172
Engine Mounting	1.8 D, 1.9 D, 1.9 D 4x4, 2.0 HDi, 2.0 HDi 4x4		<b>F8-5357</b>		
Engine Mounting	1.9 D	DW8B	<b>F8-5357</b>		
Control Arm-/Trailing Arm Bush	2.0 HDi, 2.0 HDi 4x4		<b>F8-5361</b>		
Engine Mounting	1.1, 1.4, 1.9 D 4x4, 2.0 HDi 4x4		<b>F8-5375</b>		H=34; d=12; D=30
Top Strut Mounting	1.1, 1.4, 1.8 D, 1.9 D, 2.0 HDi	;	<b>F8-5516</b>		
Top Strut Mounting	1.1, 1.4, 1.8 D, 1.9 D, 2.0 HDi	;	<b>F8-5517</b>		
Engine Mounting	1.1, 1.4, 1.8 D, 2.0 HDi		<b>F8-5568</b>		
Belt Pulley, crankshaft	1.9 D, 1.9 D 4x4, 2.0 HDi		<b>F8-5636</b>		d=30
Belt Pulley, crankshaft	2.0 HDi 4x4	Orga.→10179	<b>F8-5636</b>		d=30
Belt Pulley, crankshaft	1.8 D, 1.9 D	Number of Ribs: 6	<b>F8-5643</b>		Belt Pulley Ø [mm]=156; W=44

<b>AK-735010</b>	<b>F5-1046</b>	<b>F5-1048</b>	<b>F8-3012</b>	<b>F8-5213</b>	<b>F8-5248</b>	<b>F8-5355</b>
Ref.Nr.:	Ref.Nr.: 30667687	Ref.Nr.: 77363468	Ref.Nr.: 503527	Ref.Nr.: 5094.65	Ref.Nr.: 3523.59	Ref.Nr.: 3520.H5S1
<b>F8-5356</b>	<b>F8-5357</b>	<b>F8-5361</b>	<b>F8-5375</b>	<b>F8-5516</b>	<b>F8-5517</b>	<b>F8-5568</b>
Ref.Nr.: 328769	Ref.Nr.: 1844.47	Ref.Nr.: 3523.83	Ref.Nr.: 180906	Ref.Nr.: 503824	Ref.Nr.: 5038.23	Ref.Nr.: 184425
<b>F8-5636</b>	<b>F8-5643</b>	<b>F8-5659</b>	<b>F8-8184</b>	<b>G8-276-5017</b>	<b>G8-276-5020</b>	<b>LM-10004S</b>
Ref.Nr.: 0515P2	Ref.Nr.: 96089 38980	Ref.Nr.: 0515Q6	Ref.Nr.: 1806.33	Ref.Nr.: 5132.73	Ref.Nr.: 514851	Ref.Nr.: 7910030073

Article Description

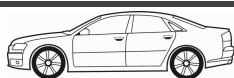

Article Nr.

Fitting Position



**PARTNER Van (5)**

04/1996 → 10/2006

Belt Pulley, crankshaft	1.9 D	DW8B; Orga. →09904;	<b>F8-5659</b>		
Belt Pulley, crankshaft	1.9 D 4x4	Orga. →09904;	<b>F8-5659</b>		
Belt Pulley, crankshaft	1.9 D	DW8B; Orga. 10178 →	<b>F8-5660</b>		
Belt Pulley, crankshaft	1.9 D 4x4	Orga. 10178 →	<b>F8-5660</b>		
Belt Pulley, crankshaft	2.0 HDi, 2.0 HDi 4x4	Orga. 10180 →	<b>F8-5660</b>		
Mounting, axle beam	1.1, 1.4, 1.8 D, 1.9 D, 2.0 HDi		<b>F8-5852</b>		H=30; D=11.5
Rubber Buffer, suspension	1.1, 1.4, 1.4 BiFuel, 1.6, 1.6 HDi 90, 1.8 D, 1.9 D, 1.9 D 4x4, 2.0 HDi, 2.0 HDi 4x4, Electric		<b>F8-5935</b>		H=109
Stabiliser Mounting	1.1, 1.4, 1.4 BiFuel, 1.8 D, 1.9 D, 1.9 D 4x4, 2.0 HDi, 2.0 HDi 4x4		<b>F8-6128</b>		d=22
Stabiliser Mounting	1.9 D	DW8B	<b>F8-6128</b>		d=22
Control Arm-/Trailing Arm Bush	1.6 HDi 90		<b>F8-6134</b>		L=56.2; D=55.5
Mounting, axle beam	1.1, 1.4, 1.4 BiFuel, 1.8 D, 1.9 D, 2.0 HDi		<b>F8-6176</b>		
Engine Mounting	1.8 D, 1.9 D, 1.9 D 4x4, 2.0 HDi, 2.0 HDi 4x4		<b>F8-6236</b>		H1=53; H2=40; d=10; D=70
Engine Mounting	1.8 D, 1.9 D, 1.9 D 4x4, 2.0 HDi, 2.0 HDi 4x4		<b>F8-6237</b>		
Repair Kit, wheel suspension	1.1, 1.4, 1.4 BiFuel, 1.6, 1.6 HDi 75, 1.6 HDi 90, 1.8 D, 1.9 D, 1.9 D 4x4, 2.0 HDi, 2.0 HDi 4x4, Electric		<b>F8-6276</b>		
Top Strut Mounting	1.1, 1.4, 1.8 D, 1.9 D		<b>F8-6296</b>		
Top Strut Mounting	1.4 BiFuel, 1.9 D 4x4, 2.0 HDi, 2.0 HDi 4x4		<b>F8-6296</b>		
Top Strut Mounting	1.1, 1.4, 1.8 D, 1.9 D	[kg]: 800;	<b>F8-6297</b>		
Belt Pulley, crankshaft	1.1, 1.4, 1.4 BiFuel, 1.6	Number of Ribs: 5; Parameter: 6PK	<b>F8-6394</b>		H=25; d=44.05; Mounting points diam.[mm]=9; D=148; D1=142.9
Engine Mounting	1.9 D 4x4, 2.0 HDi 4x4		<b>F8-6486</b>		
Engine Mounting	1.9 D, 2.0 HDi	11/2002 →	<b>F8-6486</b>		
Engine Mounting	1.1, 1.4, 1.4 BiFuel		<b>F8-6487</b>		
Engine Mounting	1.6 HDi 90	DV6ATED4	<b>F8-6500</b>		
Engine Mounting	1.6, 1.8, 1.8 D, 1.9 D, 1.9 D 4x4, 2.0 HDi, 2.0 HDi 4x4		<b>F8-6500</b>		
Engine Mounting	1.9 D	XUD9, XUD9A	<b>F8-6500</b>		
Mounting, automatic transmission	1.1, 1.4, 1.4 BiFuel		<b>F8-6505</b>		
Belt Pulley, crankshaft	1.6 HDi 90	Number of Ribs: 6; Orga. →10562	<b>F8-7082</b>		Belt Pulley Ø [mm]=152; Mounting points diam.[mm]=30; W=34
Rubber Buffer, suspension	1.1, 1.4, 1.8 D, 1.9 D, 2.0 HDi, Electric	Orga. →09799	<b>F8-7589</b>		H=81
Rubber Buffer, suspension	1.1, 1.4, 1.4 BiFuel, 1.6 HDi 90, 1.8 D, 1.9 D, 1.9 D 4x4, 2.0 HDi, 2.0 HDi 4x4, Electric	Orga. 09800 →	<b>F8-7590</b>		H=94
Engine Mounting	1.6 HDi 90		<b>F8-8184</b>		

<b>F8-5659</b>	<b>F8-5660</b>	<b>F8-5852</b>	<b>F8-5935</b>	<b>F8-6128</b>	<b>F8-6134</b>	<b>F8-6176</b>
Ref.Nr.: 0515Q6	Ref.Nr.: 0515R9	Ref.Nr.: 5131.47	Ref.Nr.: 5033.40	Ref.Nr.: 5094.77	Ref.Nr.: 3523.91	Ref.Nr.: 515262
<b>F8-6236</b>	<b>F8-6237</b>	<b>F8-6276</b>	<b>F8-6296</b>	<b>F8-6297</b>	<b>F8-6394</b>	<b>F8-6486</b>
Ref.Nr.: 1809.21	Ref.Nr.: 1809.22	Ref.Nr.: 9612314280	Ref.Nr.: 503824	Ref.Nr.: 503527	Ref.Nr.: 0515.R8	Ref.Nr.: 1844.77
<b>F8-6487</b>	<b>F8-6500</b>	<b>F8-6505</b>	<b>F8-7082</b>	<b>F8-7589</b>	<b>F8-7590</b>	<b>F8-8184</b>
Ref.Nr.: 184472	Ref.Nr.: 1844.36	Ref.Nr.: 1844.51	Ref.Nr.: 0515.R0	Ref.Nr.: 9621916980	Ref.Nr.: 5166.73	Ref.Nr.: 1806.33



**Article Description****Article Nr.****Fitting Position**

<b>PARTNER Van (5)</b>			<b>04/1996 → 10/2006</b>		
Repair Kit, wheel suspension	All Models		<b>G8-276-5017</b>		H=197; d=34; D=50,17
Repair Kit, wheel suspension	All Models		<b>G8-276-5020</b>		H=197; d=34; D=50,2
Bellow, steering	1.1, 1.4, 1.4 BiFuel, 1.6, 1.6 HDi 75, 1.6 HDi 90, 1.8 D, 1.9 D, 1.9 D 4x4, 2.0 HDi, 2.0 HDi 4x4, Electric	; with clamps;	<b>LM-10004S</b>		d1=10; d2=40; L [mm]=175
Bellow, steering	1.1, 1.4, 1.4 BiFuel, 1.6, 1.6 HDi 75, 1.6 HDi 90, 1.8 D, 1.9 D, 1.9 D 4x4, 2.0 HDi, 2.0 HDi 4x4, Electric	; with clamps;	<b>LM-10004S</b>		d1=10; d2=40; L [mm]=175
Bellow, steering	1.1	TU1M; with clamps;	<b>LM-10039S</b>		d1=40; d2=40; L [mm]=115
Bellow, steering	1.4, 1.6, 1.8, 1.8 D, 1.9 D, 2.0 HDi	with clamps;	<b>LM-10039S</b>		d1=40; d2=40; L [mm]=115
Bellow, steering	1.9 D	XUD9; with clamps;	<b>LM-10039S</b>		d1=40; d2=40; L [mm]=115
Bellow, steering	1.9 D	XUD9A; with clamps;	<b>LM-10039S</b>		d1=40; d2=40; L [mm]=115
<b>PARTNER Box</b>			<b>04/2008 →</b>		
Alternator Freewheel Clutch	1.6 HDi		<b>F5-1046</b>		
Alternator Freewheel Clutch	1.6 HDi		<b>F5-1048</b>		
Alternator Freewheel Clutch	1.6		<b>F5-1113</b>		
Alternator Freewheel Clutch	1.6		<b>F5-1132</b>		
Anti-Friction Bearing	1.6, 1.6 HDi, 1.6 HDi 90		<b>F8-3012</b>		H=20; d=66; D=100
Top Strut Mounting	1.6, 1.6 HDi, 1.6 HDi 90		<b>F8-6058</b>		
Control Arm-/Trailing Arm Bush	1.6, 1.6 HDi		<b>F8-6134</b>		L=56.2; D=55.5
Repair Kit, wheel suspension	1.6 HDi		<b>F8-6276</b>		
Top Strut Mounting	1.6, 1.6 HDi, 1.6 HDi 90		<b>F8-6302</b>		
Belt Pulley, crankshaft	1.6	Number of Ribs: 5; Parameter: 6PK	<b>F8-6394</b>		H=25; d=44.05; Mounting points diam.[mm]=9; D=148; D1=142.9
Rubber Buffer, suspension	1.6, 1.6 HDi, 1.6 HDi 90		<b>F8-7585</b>		H=96
Repair Kit, wheel suspension	1.6 HDi		<b>G8-276-5017</b>		H=197; d=34; D=50,17
Repair Kit, wheel suspension	1.6 HDi		<b>G8-276-5020</b>		H=197; d=34; D=50,2
<b>PARTNER Platform/Chassis</b>			<b>01/2009 →</b>		
Anti-Friction Bearing	1.6 HDi		<b>F8-3012</b>		H=20; d=66; D=100
Top Strut Mounting	1.6 HDi		<b>F8-6058</b>		
Repair Kit, wheel suspension	1.6 HDi		<b>F8-6276</b>		
Top Strut Mounting	1.6 HDi		<b>F8-6302</b>		
Rubber Buffer, suspension	1.6 HDi		<b>F8-7585</b>		H=96

<b>F5-1046</b>	<b>F5-1048</b>	<b>F5-1113</b>	<b>F5-1132</b>	<b>F8-3012</b>	<b>F8-6058</b>	<b>F8-6134</b>
Ref.Nr.: 30667687	Ref.Nr.: 77363468	Ref.Nr.: 12317576515	Ref.Nr.:	Ref.Nr.: 503527	Ref.Nr.: 5038.F7	Ref.Nr.: 3523.91
<b>F8-6276</b>	<b>F8-6302</b>	<b>F8-6394</b>	<b>F8-7585</b>	<b>G8-276-5017</b>	<b>G8-276-5020</b>	<b>LM-10004S</b>
Ref.Nr.: 9612314280	Ref.Nr.: 503885	Ref.Nr.: 0515.R8	Ref.Nr.: 5033.70	Ref.Nr.: 5132.73	Ref.Nr.: 514851	Ref.Nr.: 7910030073
<b>LM-10039S</b>						
Ref.Nr.: 4066.22						

Article Description



Article Nr.

Fitting Position



<b>PARTNER Platform/Chassis</b>		<b>01/2009 →</b>	
Repair Kit, wheel suspension	1.6 HDi	<b>G8-276-5017</b>	⊕ ⊕ H=197; d=34; D=50,17
Repair Kit, wheel suspension	1.6 HDi	<b>G8-276-5020</b>	⊕ ⊕ H=197; d=34; D=50,2
<b>PARTNER Tepee</b>		<b>04/2008 →</b>	
Alternator Freewheel Clutch	1.6 HDi	<b>F5-1046</b>	
Alternator Freewheel Clutch	1.6 HDi	<b>F5-1048</b>	
Alternator Freewheel Clutch	1.6	<b>F5-1113</b>	
Alternator Freewheel Clutch	1.6	<b>F5-1132</b>	
Anti-Friction Bearing	1.6, 1.6 HDi, 1.6 HDi 90	<b>F8-3012</b>	⊕ ⊕ H=20; d=66; D=100
Top Strut Mounting	1.6, 1.6 HDi, 1.6 HDi 90	<b>F8-6058</b>	⊕ ⊕
Control Arm-/Trailing Arm Bush	1.6, 1.6 HDi	<b>F8-6134</b>	L=56.2; D=55.5
Top Strut Mounting	1.6, 1.6 HDi, 1.6 HDi 90	<b>F8-6302</b>	
Belt Pulley, crankshaft	1.6	<b>F8-6394</b>	H=25; d=44.05; Mounting points diam.[mm]=9; D=148; D1=142.9
Rubber Buffer, suspension	1.6, 1.6 HDi, 1.6 HDi 90	<b>F8-7585</b>	⊕ ⊕ H=96
<b>RCZ</b>		<b>03/2010 →</b>	
Alternator Freewheel Clutch	1.6 16V	<b>F5-1113</b>	
Alternator Freewheel Clutch	1.6 16V	<b>F5-1132</b>	
Spring Cap	1.6 16V, 2.0 HDi	<b>F8-6562</b>	

<b>F5-1046</b>	<b>F5-1048</b>	<b>F5-1113</b>	<b>F5-1132</b>	<b>F8-3012</b>	<b>F8-6058</b>	<b>F8-6134</b>
Ref.Nr.: 30667687	Ref.Nr.: 77363468	Ref.Nr.: 12317576515	Ref.Nr.:	Ref.Nr.: 503527	Ref.Nr.: 5038.F7	Ref.Nr.: 3523.91
<b>F8-6302</b>	<b>F8-6394</b>	<b>F8-6562</b>	<b>F8-7585</b>	<b>G8-276-5017</b>	<b>G8-276-5020</b>	
Ref.Nr.: 503885	Ref.Nr.: 0515.R8	Ref.Nr.: 5033.75	Ref.Nr.: 5033.70	Ref.Nr.: 5132.73	Ref.Nr.: 514851	

**Article Description****Article Nr.****Fitting Position**

<b>911 (964)</b>		<b>12/1988 → 09/1993</b>	
Dust Cover Kit, shock absorber	All Models	AK-735157	
Dust Cover Kit, shock absorber	3.6 Carrera, 3.6 Carrera 4	AK-735158	
Dust Cover Kit, shock absorber	3.3 Turbo, 3.3 Turbo S, 3.6 Carrera RS, 3.6 Turbo	AK-735159	
Dust Cover Kit, shock absorber	3.6 Carrera, 3.6 Carrera 4	AK-735159	
		08/1900 →	
<b>911 (993)</b>		<b>10/1993 → 09/1997</b>	
Dust Cover Kit, shock absorber	3.6 Carrera, 3.6 Carrera 4, 3.6 Turbo 4, 3.6 Turbo GT2, 3.6 Turbo GT2 4, 3.8 Carrera, 3.8 Carrera 4, 3.8 Carrera RS, 3.8 Carrera RS 4	AK-735160	
Dust Cover Kit, shock absorber	3.6 Carrera, 3.6 Carrera 4, 3.6 Turbo 4, 3.6 Turbo GT2, 3.6 Turbo GT2 4, 3.8 Carrera, 3.8 Carrera 4, 3.8 Carrera RS, 3.8 Carrera RS 4	AK-735161	
<b>911 (996)</b>		<b>09/1997 → 08/2005</b>	
Dust Cover Kit, shock absorber	All Models	AK-735162	
Dust Cover Kit, shock absorber	3.4 Carrera, 3.4 Carrera 4, 3.6 Carrera, 3.6 Carrera 4, 3.6 GT2, 3.6 GT3, 3.6 S	AK-735163	
Dust Cover Kit, shock absorber	3.6 Carrera 4S, 3.6 Carrera S, 3.6 Turbo 4, 3.6 Turbo 4S	AK-735164	
Alternator Freewheel Clutch	3.4 Carrera, 3.4 Carrera 4, 3.6 Carrera, 3.6 Carrera 4, 3.6 Carrera 4S, 3.6 Carrera S, 3.6 GT2, 3.6 S, 3.6 Turbo 4, 3.6 Turbo 4S	F5-1086	
<b>911 Convertible (996)</b>		<b>02/1998 → 08/2005</b>	
Dust Cover Kit, shock absorber	All Models	AK-735162	
Dust Cover Kit, shock absorber	3.4 Carrera, 3.4 Carrera 4, 3.6 Carrera, 3.6 Carrera 4, 3.6 S	AK-735163	
Dust Cover Kit, shock absorber	3.6 Carrera 4S, 3.6 Carrera S, 3.6 Turbo 4, 3.6 Turbo 4S	AK-735164	
Alternator Freewheel Clutch	All Models	F5-1086	
<b>911 Targa (996)</b>		<b>12/2001 → 08/2005</b>	
Dust Cover Kit, shock absorber	All Models	AK-735162	
Dust Cover Kit, shock absorber	All Models	AK-735163	
Alternator Freewheel Clutch	All Models	F5-1086	
<b>911 (997)</b>		<b>07/2004 → 12/2012</b>	
Dust Cover Kit, shock absorber	3.6 Carrera, 3.6 Carrera 4, 3.6 GT 2, 3.6 GT 3, 3.6 Turbo, 3.8 Carrera 4S, 3.8 Carrera S	AK-735162	
Dust Cover Kit, shock absorber	3.6 Carrera, 3.6 Carrera 4, 3.6 GT 2, 3.6 GT 3, 3.6 Turbo	AK-735163	
Dust Cover Kit, shock absorber	3.8 Carrera 4S, 3.8 Carrera S	AK-735165	
Alternator Freewheel Clutch	3.6 Carrera, 3.6 Carrera 4, 3.6 GT 2, 3.6 GT 2 RS, 3.6 Turbo, 3.8 Carrera 4S, 3.8 Carrera S	F5-1086	

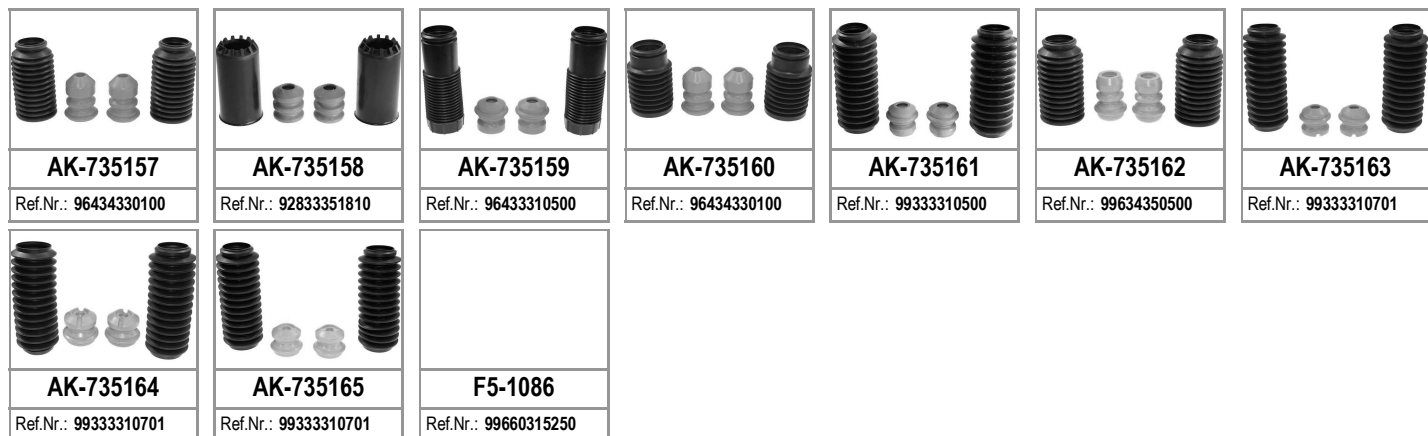

Article Description



Article Nr.

Fitting Position



			04/2005 → 12/2009	
<b>911 Convertible (997)</b>				
Dust Cover Kit, shock absorber	3.6 Carrera, 3.6 Carrera 4, 3.6 Turbo, 3.8 Carrera 4S, 3.8 Carrera S		AK-735162	
Dust Cover Kit, shock absorber	3.6 Carrera, 3.6 Carrera 4, 3.6 Turbo		AK-735163	
Dust Cover Kit, shock absorber	3.8 Carrera 4S, 3.8 Carrera S		AK-735165	
Alternator Freewheel Clutch	3.6 Carrera, 3.6 Carrera 4, 3.6 Turbo, 3.8 Carrera 4S, 3.8 Carrera S		F5-1086	
			07/2006 → 12/2008	
<b>911 Targa (997)</b>				
Alternator Freewheel Clutch	3.6 Carrera 4, 3.8 Carrera 4S		F5-1086	
			11/1975 → 08/1989	
<b>924</b>				
Control Arm-/Trailing Arm Bush	2.0, 2.0 Turbo		G9-540	H=55; d=16; D=38
Control Arm-/Trailing Arm Bush	All Models		G9-541	H=62; d=12; D=34
Bellow, steering	All Models	with clamps	LM-10064S	d1=25; d2=35; L [mm]=144
			06/1981 → 07/1991	
<b>944</b>				
Control Arm-/Trailing Arm Bush	2.5		G9-541	H=62; d=12; D=34
Bellow, steering	2.5 S, 2.5 Turbo	ch.→1H-TW500000; with clamps;	LM-10024S	d1=25; d2=41; L [mm]=120
Bellow, steering	2.5, 2.5 S, 2.5 Turbo, 2.7	with clamps;	LM-10024S	d1=25; d2=41; L [mm]=120
Bellow, steering	2.5, 2.5 S, 2.5 Turbo, 2.7	with clamps;	LM-10024S	d1=25; d2=41; L [mm]=120
Bellow, steering	2.5, 2.5 Turbo, 3.0 S2	with clamps;	LM-10024S	d1=25; d2=41; L [mm]=120
Bellow, steering	2.5 S	ch.→1H-TW500000; with clamps;	LM-10050S	d1=25; d2=39; L [mm]=126
Bellow, steering	2.5 S, 2.5 Turbo	ch.→1H-TW500000; with clamps;	LM-10050S	d1=25; d2=39; L [mm]=126
Bellow, steering	2.5, 2.5 Turbo, 3.0 S2	with clamps;	LM-10050S	d1=25; d2=39; L [mm]=126
Bellow, steering	2.5, 2.7	with clamps;	LM-10050S	d1=25; d2=39; L [mm]=126
			12/1988 → 07/1991	
<b>944 Convertible</b>				
Bellow, steering	3.0 S2	with clamps;	LM-10024S	d1=25; d2=41; L [mm]=120
Bellow, steering	3.0 S2	with clamps;	LM-10050S	d1=25; d2=39; L [mm]=126
			06/1991 → 11/1995	
<b>968</b>				
Dust Cover Kit, shock absorber	All Models		AK-735166	
			06/1991 → 11/1995	
<b>968 Convertible</b>				
Dust Cover Kit, shock absorber	All Models		AK-735166	
			09/1996 → 12/2004	
<b>BOXSTER (986)</b>				
Dust Cover Kit, shock absorber	2.5, 2.7, S 3.2, S 3.2		AK-735162	
Dust Cover Kit, shock absorber	2.5, 2.7, S 3.2, S 3.2		AK-735167	
Alternator Freewheel Clutch	2.7, S 3.2, S 3.2		F5-1086	

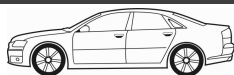

**Article Description****Article Nr.****Fitting Position**

<b>BOXSTER (987)</b>		<b>11/2004 → 12/2009</b>	
Dust Cover Kit, shock absorber	2.7, S 3.2, S 3.4	AK-735162	
Dust Cover Kit, shock absorber	2.7, S 3.2, S 3.4	AK-735167	
Alternator Freewheel Clutch	2.7, S 3.2, S 3.4	F5-1086	
<b>CAYENNE (955, 9PA)</b>		<b>09/2002 → 09/2010</b>	
Dust Cover Kit, shock absorber	3.2, 3.6, S 4.5, S 4.8, Turbo 4.5, Turbo S 4.5, Turbo S 4.8	AK-735162	
Dust Cover Kit, shock absorber	3.2, 3.6, S 4.5, S 4.8, Turbo 4.5, Turbo S 4.5, Turbo S 4.8	AK-735168	
Control Arm-/Trailing Arm Bush	3.0 TDI, 3.2, 3.6, GTS 4.8, S 4.5, S 4.8, Turbo 4.5, Turbo S 4.5, Turbo S 4.8	F8-5301	 d=14.2; L=74; D=46,5
Control Arm-/Trailing Arm Bush	3.2, 3.6, GTS 4.8, S 4.5, S 4.8, Turbo 4.5, Turbo S 4.5, Turbo S 4.8	F8-6705	 H=43; d=10; D=40
Control Arm-/Trailing Arm Bush	3.2, 3.6, GTS 4.8, S 4.5, S 4.8, Turbo 4.5, Turbo S 4.5, Turbo S 4.8	F8-6706	 D=60.05
Control Arm-/Trailing Arm Bush	All Models	F8-6707	 
Mounting, axle beam	All Models	F8-8131	 H=62; d=23; D=93
Bellow, steering	All Models	LM-10100S	 d1=15.5; d2=66; L [mm]=195
<b>CAYENNE (92A)</b>		<b>06/2010 →</b>	
Alternator Freewheel Clutch	3.0 Diesel	F5-1140	
Mounting, axle beam	3.0 Diesel, 3.0 S, 3.0 S Hybrid, 3.6, 4.2 S Diesel, 4.8 GTS, 4.8 S, 4.8 Turbo, 4.8 Turbo S	F8-8131	 H=62; d=23; D=93
Bellow, steering	3.0 Diesel, 3.0 S Hybrid, 3.6, 4.8 S, 4.8 Turbo	LM-10100S	 d1=15.5; d2=66; L [mm]=195
<b>CAYMAN (987)</b>		<b>11/2005 → 12/2012</b>	
Dust Cover Kit, shock absorber	2.7, S 3.4	AK-735162	
Dust Cover Kit, shock absorber	2.7, S 3.4	AK-735169	
Alternator Freewheel Clutch	2.7, S 3.4 Sport, S 3.4	F5-1086	
<b>PANAMERA (970)</b>		<b>09/2009 →</b>	
Alternator Freewheel Clutch	3.0 D	F5-1140	
Control Arm-/Trailing Arm Bush	3.0 D, 3.0 S E-Hybrid, 3.0 S Hybrid, 3.6, 3.6 4, 4.8 4S, 4.8 GTS, 4.8 S, 4.8 Turbo, 4.8 Turbo S	F8-6705	 H=43; d=10; D=40

<b>AK-735162</b>	<b>AK-735167</b>	<b>AK-735168</b>	<b>AK-735169</b>	<b>F5-1086</b>	<b>F5-1140</b>	<b>F8-5301</b>
Ref.Nr.: 99634350500	Ref.Nr.: 98633350501	Ref.Nr.: 95533310520	Ref.Nr.: 98633350501	Ref.Nr.: 99660315250	Ref.Nr.: 059903119L	Ref.Nr.: 95534324301
<b>F8-6705</b>	<b>F8-6706</b>	<b>F8-6707</b>	<b>F8-8131</b>	<b>LM-10100S</b>		
Ref.Nr.: 7L0407077	Ref.Nr.: 7L0407182C	Ref.Nr.: 7L0407183A	Ref.Nr.: 7L0499035A	Ref.Nr.: 32106765782		

Article Description



Article Nr.

Fitting Position



			10/1962 → 06/1993	
<b>4 (112_)</b>				
Control Arm-/Trailing Arm Bush	0.8, 1.0, 1.1		F8-6818	⊕ ⊕ ↑
Top Strut Mounting	0.8, 1.0, 1.1		F8-7052	⊕ ⊕ ⊕
Bellow, steering	0.8, 1.0, 1.1	with clamps	LM-10013S	⊕ ⊕ ⊕ d1=10; d2=34; L [mm]=162
Bellow, steering	0.8, 1.1	07/1979 →; with clamps	LM-10013S	⊕ ⊕ ⊕ d1=10; d2=34; L [mm]=162
			09/1966 → 12/1993	
<b>4 Box (R21_, R23_)</b>				
Control Arm-/Trailing Arm Bush	0.8, 1.1		F8-6818	⊕ ⊕ ⊕ ↑
Top Strut Mounting	0.8, 1.1		F8-7052	⊕ ⊕ ⊕
Bellow, steering	0.8, 1.0, 1.1	with clamps	LM-10013S	⊕ ⊕ ⊕ d1=10; d2=34; L [mm]=162
Bellow, steering	0.8, 1.1	07/1979 →; with clamps	LM-10013S	⊕ ⊕ ⊕ d1=10; d2=34; L [mm]=162
			01/1972 → 12/1985	
<b>5 (122_)</b>				
Anti-Friction Bearing	1.0, 1.1, 1.3, 1.3 Automatik, 1.4, 1.4 Alpine A5, 1.4 Alpine Turbo, 1.4 Automatik, 1.4 Turbo		F8-3033	⊕ ⊕ ⊕ H=20; d1=62; d2=64; D=100
Top Strut Mounting	1.0, 1.1, 1.3, 1.3 Automatik, 1.4, 1.4 Alpine A5, 1.4 Alpine Turbo, 1.4 Automatik, 1.4 Turbo		F8-5500	⊕ ⊕ ⊕
Bearing, drive shaft	0.8, 1.0, 1.1, 1.3, 1.3 Automatik, 1.4, 1.4 Alpine A5, 1.4 Alpine Turbo, 1.4 Automatik, 1.4 Turbo		F8-7173	⊕ ⊕ ⊕ d=25.8
Bellow, steering	0.8, 1.0, 1.3, 1.3 Automatik, 1.4 Alpine A5	07/1979 →; with clamps	LM-10013S	⊕ ⊕ ⊕ d1=10; d2=34; L [mm]=162
Bellow, steering	0.8, 1.1, 1.4, 1.4 Alpine Turbo, 1.4 Automatik, 1.4 Turbo	with clamps	LM-10013S	⊕ ⊕ ⊕ d1=10; d2=34; L [mm]=162
			01/1972 → 12/1985	
<b>5 Box (238_)</b>				
Anti-Friction Bearing	0.8, 1.0, 1.1		F8-3033	⊕ ⊕ ⊕ H=20; d1=62; d2=64; D=100
Top Strut Mounting	0.8, 1.0, 1.1		F8-5500	⊕ ⊕ ⊕
			10/1969 → 04/1987	
<b>6 (118_)</b>				
Bellow, steering	All Models	07/1979 →; with clamps	LM-10013S	⊕ ⊕ ⊕ d1=10; d2=34; L [mm]=162
			09/1981 → 12/1989	
<b>9 (L42_)</b>				
Dust Cover Kit, shock absorber	1.1, 1.2, 1.4, 1.4 Automatik, 1.4 Turbo, 1.6 D, 1.7		AK-735042	⊕ ⊕ ⊕
Anti-Friction Bearing	1.1, 1.2, 1.4, 1.4 Automatik, 1.4 Turbo, 1.6 D, 1.7		F8-3033	⊕ ⊕ ⊕ H=20; d1=62; d2=64; D=100
Top Strut Mounting	1.1, 1.2, 1.4, 1.4 Automatik, 1.4 Turbo, 1.6 D, 1.7		F8-5617	⊕ ⊕ ⊕
Repair Set, axle beam	1.1, 1.2, 1.4, 1.4 Automatik, 1.4 Turbo, 1.6 D, 1.7		F8-6097	⊕ ⊕ ⊕
Stabiliser Mounting	1.1, 1.2, 1.4, 1.4 Automatik, 1.4 Turbo, 1.6 D, 1.7		F8-6798	⊕ ⊕ ⊕ d=23
Engine Mounting	1.1, 1.2, 1.4, 1.4 Automatik, 1.4 Turbo, 1.6 D, 1.7		F8-6841	↓
Engine Mounting	1.1, 1.2, 1.4, 1.7		F8-6864	⊕
Engine Mounting	1.1, 1.2, 1.4, 1.4 Automatik, 1.4 Turbo, 1.6 D, 1.7		F8-6910	⊕
Bearing, drive shaft	1.1		F8-7173	⊕ ⊕ ⊕ d=25.8

<b>AK-735042</b>	<b>F8-3033</b>	<b>F8-5500</b>	<b>F8-5617</b>	<b>F8-6097</b>	<b>F8-6798</b>	<b>F8-6818</b>
Ref.Nr.: 7700776743	Ref.Nr.: 7700797666	Ref.Nr.: 6001009755	Ref.Nr.: 77 00 760 571	Ref.Nr.: 7701464321	Ref.Nr.: 7700693154	Ref.Nr.: 7700518392
<b>F8-6841</b>	<b>F8-6864</b>	<b>F8-6910</b>	<b>F8-7052</b>	<b>F8-7173</b>	<b>G9-570</b>	<b>LM-10013S</b>
Ref.Nr.: 7700760488	Ref.Nr.: 7700762721	Ref.Nr.: 7704001320	Ref.Nr.: 7700500113	Ref.Nr.: 7664079	Ref.Nr.: 7700762574	Ref.Nr.: 7700656569

**Article Description****Article Nr.****Fitting Position**

			<b>09/1981 → 12/1989</b>	
Control Arm-/Trailing Arm Bush	1.1, 1.2, 1.4, 1.4 Automatik, 1.4 Turbo, 1.6 D, 1.7		<b>G9-570</b>	
Bellow, steering	1.1, 1.2, 1.4, 1.4 Automatik, 1.4 Turbo, 1.6 D, 1.7	with clamps	<b>LM-10055S</b>	
Bellow Set, drive shaft	1.1, 1.2, 1.4, 1.4 Automatik, 1.6 D, 1.7		<b>M-850850</b>	
Bellow Set, drive shaft	1.1, 1.2, 1.4, 1.6 D, 1.7		<b>MK-850850</b>	
Bellow Set, drive shaft	1.4 Automatik		<b>MK-850850</b>	
Bellow Set, drive shaft	1.4 Automatik, 1.6 D		<b>MK-860860</b>	
			<b>03/1983 → 12/1988</b>	
Dust Cover Kit, shock absorber	1.7		<b>AK-735042</b>	
Anti-Friction Bearing	1.1, 1.2, 1.4, 1.4 Turbo, 1.6 D, 1.7		<b>F8-3033</b>	
Top Strut Mounting	1.1, 1.2, 1.4, 1.4 Turbo, 1.6 D, 1.7		<b>F8-5617</b>	
Repair Set, axle beam	1.1, 1.2, 1.4, 1.4 Turbo, 1.6 D, 1.7		<b>F8-6097</b>	
Stabiliser Mounting	1.1, 1.2, 1.4, 1.4 Turbo, 1.6 D, 1.7		<b>F8-6798</b>	
Engine Mounting	1.1, 1.2, 1.4, 1.4 Turbo, 1.6 D, 1.7		<b>F8-6841</b>	
Engine Mounting	1.1, 1.2, 1.4, 1.7		<b>F8-6864</b>	
Engine Mounting	1.1, 1.2, 1.4, 1.4 Turbo, 1.6 D, 1.7		<b>F8-6910</b>	
Bearing, drive shaft	1.1		<b>F8-7173</b>	
Control Arm-/Trailing Arm Bush	1.1, 1.2, 1.4, 1.4 Turbo, 1.6 D, 1.7		<b>G9-570</b>	
Bellow, steering	1.1, 1.2, 1.4, 1.4 Turbo, 1.6 D, 1.7	with clamps	<b>LM-10055S</b>	
Bellow Set, drive shaft	1.1, 1.2, 1.4, 1.6 D, 1.7		<b>M-850850</b>	
Bellow Set, drive shaft	1.1, 1.2, 1.4, 1.6 D, 1.7		<b>MK-850850</b>	
Bellow Set, drive shaft	1.6 D		<b>MK-860860</b>	
			<b>03/1983 → 12/1988</b>	
Anti-Friction Bearing	1.1, 1.2, 1.4, 1.6 D		<b>F8-3033</b>	
Repair Set, axle beam	1.1, 1.2, 1.4, 1.6 D		<b>F8-6097</b>	
Control Arm-/Trailing Arm Bush	All Models		<b>G9-570</b>	
Bellow, steering	All Models	with clamps	<b>LM-10055S</b>	
Bellow Set, drive shaft	All Models		<b>M-850850</b>	
Bellow Set, drive shaft	All Models		<b>MK-850850</b>	
			<b>05/1976 → 12/1983</b>	
Bellow, steering	1.2	07/1979 →; with clamps	<b>LM-10013S</b>	
Bellow, steering	1.2, 1.4	with clamps	<b>LM-10013S</b>	

<b>AK-735042</b>	<b>F8-3033</b>	<b>F8-5617</b>	<b>F8-6097</b>	<b>F8-6798</b>	<b>F8-6841</b>	<b>F8-6864</b>
Ref.Nr.: 7700776743	Ref.Nr.: 7700797666	Ref.Nr.: 77 00 760 571	Ref.Nr.: 7701464321	Ref.Nr.: 7700693154	Ref.Nr.: 7700760488	Ref.Nr.: 7700762721
<b>F8-6910</b>	<b>F8-7173</b>	<b>G9-570</b>	<b>LM-10013S</b>	<b>LM-10055S</b>	<b>M-850850</b>	<b>MK-850850</b>
Ref.Nr.: 7704001320	Ref.Nr.: 7664079	Ref.Nr.: 7700762574	Ref.Nr.: 7700656569	Ref.Nr.: 7700653459	Ref.Nr.: 329373	Ref.Nr.: 329373
<b>MK-860860</b>						
Ref.Nr.: 7701462100						

Article Description



Article Nr.

Fitting Position



			09/1968 → 08/1980	
Bellow Set, drive shaft	1.6 TL		MK-850850	
Bellow Set, drive shaft	1.6 TS, 1.6 TX		MK-850850	
			04/1978 → 07/1986	
Control Arm-/Trailing Arm Bush	1.4, 1.6, 1.6 TS, 1.6 Turbo, 2.0, 2.1 Diesel, 2.1 TD, 2.2 i		G9-600	
Bellow Set, drive shaft	1.4, 1.6 TS, 2.1 Diesel		MK-850850	
Bellow Set, drive shaft	1.6		MK-850850	
			05/1979 → 07/1986	
Bellow Set, drive shaft	All Models		MK-850850	
			05/1979 → 07/1986	
Bellow Set, drive shaft	2.1 Diesel		M-850850	
Bellow Set, drive shaft	1.4, 1.6 TS, 2.1 Diesel		MK-850850	
Bellow Set, drive shaft	1.6		MK-850850	
			01/1988 → 12/1992	
Dust Cover Kit, shock absorber	1.2, 1.4, 1.7, 1.8 16V, 1.9 D		AK-735042	
Anti-Friction Bearing	1.2, 1.4, 1.7, 1.8 16V, 1.9 D, 1.9 DT		F8-3033	
Engine Mounting	1.4, 1.7		F8-4109	
Engine Mounting	1.8 16V	02/1990 →; Type: B53D	F8-4109	
Engine Mounting	1.4, 1.7, 1.8 16V		F8-4110	
Stabiliser Mounting	1.4, 1.7, 1.8 16V, 1.9 D		F8-5085	
Top Strut Mounting	1.4, 1.7, 1.9 D		F8-5473	
Engine Mounting	1.9 D, 1.9 DT		F8-5481	
Engine Mounting	1.4		F8-5482	
Engine Mounting	1.7, 1.8 16V		F8-5482	
Mounting, automatic transmission	1.4	01/1987 →;	F8-5485	
Mounting, automatic transmission	1.4, 1.7, 1.9 D		F8-5485	
Mounting, automatic transmission	1.8 16V		F8-5485	
Engine Mounting	1.9 D		F8-5536	
Belt Pulley, crankshaft	1.9 D, 1.9 DT		F8-5645	
Top Strut Mounting	1.8 16V		F8-5850	
Repair Set, axle beam	1.2, 1.4, 1.7, 1.9 D		F8-6097	
Top Strut Mounting	1.2		F8-6331	
Top Strut Mounting	1.4		F8-6331	





**Article Description****Article Nr.****Fitting Position**

<b>19 (B/C53_)</b>			<b>01/1988 → 12/1992</b>		
Top Strut Mounting	1.4	☺; Type: B531, C531	<b>F8-6331</b>		
Top Strut Mounting	1.2, 1.4, 1.7, 1.8 16V, 1.9 DT	☺	<b>F8-6379</b>		
Top Strut Mounting	1.4	☺; Type: B537, B53A, B53G, B53H	<b>F8-6379</b>		
Top Strut Mounting	1.7	☺; Type: B533, B536, B53B, B53E, B53M	<b>F8-6379</b>		
Top Strut Mounting	1.7	☺; Type: B53B, B53F	<b>F8-6379</b>		
Top Strut Mounting	1.9 D	☺; Type: B534, B53I, B53J, B53K, B53T, B53Z, C534, C53J	<b>F8-6379</b>		
Stabiliser Mounting	1.2, 1.4, 1.7, 1.8 16V, 1.9 D		<b>F8-6796</b>		d=18
Bearing, drive shaft	1.4, 1.9 D		<b>F8-7173</b>		d=25.8
Stabiliser Mounting	1.4, 1.7, 1.8 16V, 1.9 D		<b>F8-7942</b>		
Control Arm-/Trailing Arm Bush	1.2, 1.4, 1.7, 1.9 D		<b>G9-569</b>		H=46; d=12; D1=45; D2=48
Control Arm-/Trailing Arm Bush	1.8 16V		<b>G9-653</b>		H1=35; H2=46; d=12; D=45
Bellow, steering	1.2, 1.4, 1.7, 1.8 16V, 1.9 D	with clamps; ☹	<b>LM-10001S</b>		d1=10; d2=30; L [mm]=158
Bellow, steering	1.2, 1.4, 1.7, 1.8 16V, 1.9 D	with clamps; ☹	<b>LM-10002S</b>		d1=10; d2=40; L [mm]=160
Bellow, steering	1.2, 1.4, 1.7, 1.8 16V, 1.9 D	with clamps; ☹	<b>LM-10042S</b>		d1=10; d2=27.5; L [mm]=155
Bellow Set, drive shaft	1.2, 1.4, 1.7, 1.9 D		<b>M-850850</b>		H=120; d1=28; d2=75.5
Bellow Set, drive shaft	1.2, 1.4, 1.7, 1.8 16V, 1.9 D		<b>M-860860</b>		H=80; d2=85; D1=25.8
Bellow Set, drive shaft	1.2, 1.4, 1.7, 1.9 D		<b>M-870870</b>		
Bellow Set, drive shaft	1.2, 1.4, 1.7, 1.9 D	☹	<b>MK-850850</b>		
Bellow Set, drive shaft	1.4, 1.7		<b>MK-860860</b>		D1=25.8; D2113.5; L=88
Bellow Set, drive shaft	1.4, 1.9 D	☹	<b>MK-870870</b>		
Bellow Set, drive shaft	1.7	☹	<b>MK-870870</b>		
<b>19 Convertible (D53_)</b>			<b>07/1991 → 04/1992</b>		
Dust Cover Kit, shock absorber	1.7, 1.8 16V		<b>AK-735042</b>		
Anti-Friction Bearing	1.7, 1.8 16V		<b>F8-3033</b>		H=20; d1=62; d2=64; D=100
Top Strut Mounting	1.7, 1.8 16V	☹	<b>F8-5473</b>		
Mounting, automatic transmission	1.7	☹	<b>F8-5485</b>		
Top Strut Mounting	1.7, 1.8 16V	☺	<b>F8-6379</b>		
Stabiliser Mounting	1.7, 1.8 16V		<b>F8-6796</b>		d=18
Stabiliser Mounting	1.7, 1.8 16V		<b>F8-7942</b>		
Control Arm-/Trailing Arm Bush	1.7		<b>G9-569</b>		H=46; d=12; D1=45; D2=48
Control Arm-/Trailing Arm Bush	1.8 16V		<b>G9-653</b>		H1=35; H2=46; d=12; D=45

<b>AK-735042</b>	<b>F8-3033</b>	<b>F8-5473</b>	<b>F8-5485</b>	<b>F8-6331</b>	<b>F8-6379</b>	<b>F8-6796</b>
Ref.Nr.: 7700776743	Ref.Nr.: 7700797666	Ref.Nr.: 7700780875	Ref.Nr.: 7700788318	Ref.Nr.: 7700793723	Ref.Nr.: 7700797654	Ref.Nr.: 7700784170
<b>F8-7173</b>	<b>F8-7942</b>	<b>G9-569</b>	<b>G9-653</b>	<b>LM-10001S</b>	<b>LM-10002S</b>	<b>LM-10042S</b>
Ref.Nr.: 7664079	Ref.Nr.: 7700784171	Ref.Nr.: 7700789478	Ref.Nr.: 7700789477	Ref.Nr.: 7700678649	Ref.Nr.: 7700706007	Ref.Nr.: 7701469497
<b>M-850850</b>	<b>M-860860</b>	<b>M-870870</b>	<b>MK-850850</b>	<b>MK-860860</b>	<b>MK-870870</b>	
Ref.Nr.: 329373	Ref.Nr.: 7701462308	Ref.Nr.: 7701450617	Ref.Nr.: 329373	Ref.Nr.: 7701462100	Ref.Nr.: 7701450617	

Article Description



Article Nr.

Fitting Position



19 Convertible (D53_)			07/1991 → 04/1992		
Bellow, steering	1.7, 1.8 16V	with clamps;	LM-10001S		d1=10; d2=30; L [mm]=158
Bellow, steering	1.7, 1.8 16V	with clamps;	LM-10002S		d1=10; d2=40; L [mm]=160
Bellow, steering	1.7, 1.8 16V	with clamps;	LM-10042S		d1=10; d2=27.5; L [mm]=155
Bellow Set, drive shaft	1.7		M-850850		H=120; d1=28; d2=75.5
Bellow Set, drive shaft	1.7, 1.8 16V		M-860860		H=80; d2=85; D1=25.8
Bellow Set, drive shaft	1.7		MK-850850		
19 Saloon (L53_)			01/1988 → 12/1992		
Dust Cover Kit, shock absorber	1.2, 1.4, 1.7, 1.8 16V, 1.9 D, 1.9 TD		AK-735042		
Anti-Friction Bearing	1.1 TR, 1.2, 1.4, 1.7, 1.8 16V, 1.9 D, 1.9 DT, 1.9 TD		F8-3033		H=20; d1=62; d2=64; D=100
Engine Mounting	1.4, 1.7		F8-4109		
Engine Mounting	1.7	09/1990 →	F8-4109		
Engine Mounting	1.8 16V	02/1990 →	F8-4109		
Engine Mounting	1.7, 1.8 16V		F8-4110		d=12; D=99; T [mm]=119
Stabiliser Mounting	1.4, 1.7, 1.8 16V, 1.9 D		F8-5085		d=23
Top Strut Mounting	1.4, 1.7, 1.9 D		F8-5473		
Engine Mounting	1.9 D, 1.9 DT, 1.9 TD		F8-5481		Outer Thread [mm]=M10
Engine Mounting	1.4, 1.7		F8-5482		
Engine Mounting	1.8 16V	02/1990 →	F8-5482		
Mounting, automatic transmission	1.4, 1.7, 1.9 D		F8-5485		
Engine Mounting	1.9 D		F8-5536		
Belt Pulley, crankshaft	1.9 D, 1.9 DT, 1.9 TD		F8-5645		
Top Strut Mounting	1.8 16V		F8-5850		
Repair Set, axle beam	1.2, 1.4, 1.7, 1.9 D		F8-6097		
Top Strut Mounting	1.2		F8-6331		
Top Strut Mounting	1.4	; Type: L531, L532	F8-6331		
Top Strut Mounting	1.1 TR, 1.2, 1.4, 1.7, 1.8 16V, 1.9 DT, 1.9 TD		F8-6379		
Top Strut Mounting	1.4	; Type: L535, L53P	F8-6379		
Top Strut Mounting	1.9 D	; Type: L534, L53J	F8-6379		
Stabiliser Mounting	1.2, 1.4, 1.7, 1.8 16V, 1.9 D, 1.9 TD		F8-6796		d=18
Bearing, drive shaft	1.9 D, 1.9 TD		F8-7173		d=25.8
Stabiliser Mounting	1.4, 1.7, 1.8 16V, 1.9 D		F8-7942		
Control Arm-/Trailing Arm Bush	1.2, 1.4, 1.7, 1.9 D		G9-569		H=46; d=12; D1=45; D2=48
Control Arm-/Trailing Arm Bush	1.8 16V		G9-653		H1=35; H2=46; d=12; D=45

<b>AK-735042</b>	<b>F8-3033</b>	<b>F8-4109</b>	<b>F8-4110</b>	<b>F8-5085</b>	<b>F8-5473</b>	<b>F8-5481</b>
Ref.Nr.: 7700776743	Ref.Nr.: 7700797666	Ref.Nr.: 7700785949	Ref.Nr.: 7700805733	Ref.Nr.: 7700785788	Ref.Nr.: 7700780875	Ref.Nr.: 7700802927
<b>F8-5482</b>	<b>F8-5485</b>	<b>F8-5536</b>	<b>F8-5645</b>	<b>F8-5850</b>	<b>F8-6097</b>	<b>F8-6331</b>
Ref.Nr.: 7700794601	Ref.Nr.: 7700788318	Ref.Nr.: 7700411638	Ref.Nr.: 7700724249	Ref.Nr.: 7700840234	Ref.Nr.: 7701464321	Ref.Nr.: 7700793723
<b>F8-6379</b>	<b>F8-6796</b>	<b>F8-7173</b>	<b>F8-7942</b>	<b>G9-569</b>	<b>G9-653</b>	<b>LM-10001S</b>
Ref.Nr.: 7700797654	Ref.Nr.: 7700784170	Ref.Nr.: 7664079	Ref.Nr.: 7700784171	Ref.Nr.: 7700789478	Ref.Nr.: 7700789477	Ref.Nr.: 7700678649

**Article Description****Article Nr.****Fitting Position**

<b>19 Saloon (L53_)</b>			<b>01/1988 → 12/1992</b>		
Bellow, steering	1.2, 1.4, 1.7, 1.8 16V, 1.9 D, 1.9 TD	with clamps;	<b>LM-10001S</b>		d1=10; d2=30; L [mm]=158
Bellow, steering	1.2, 1.4, 1.7, 1.8 16V, 1.9 D, 1.9 TD	with clamps;	<b>LM-10002S</b>		d1=10; d2=40; L [mm]=160
Bellow, steering	1.2, 1.4, 1.7, 1.8 16V, 1.9 D, 1.9 TD	with clamps;	<b>LM-10042S</b>		d1=10; d2=27.5; L [mm]=155
Bellow Set, drive shaft	1.2, 1.4, 1.7, 1.9 D		<b>M-850850</b>		H=120; d1=28; d2=75.5
Bellow Set, drive shaft	1.2, 1.4, 1.7, 1.8 16V, 1.9 D, 1.9 TD		<b>M-860860</b>		H=80; d2=85; D1=25.8
Bellow Set, drive shaft	1.2, 1.4, 1.7, 1.9 D		<b>M-870870</b>		
Bellow Set, drive shaft	1.2, 1.4, 1.7, 1.9 D		<b>MK-850850</b>		
Bellow Set, drive shaft	1.4, 1.7		<b>MK-860860</b>		D1=25.8; D2113.5; L=88
Bellow Set, drive shaft	1.4, 1.9 D		<b>MK-870870</b>		
<b>19 Box (S53_)</b>			<b>01/1988 → 12/1992</b>		
Anti-Friction Bearing	All Models		<b>F8-3033</b>		H=20; d1=62; d2=64; D=100
Engine Mounting	1.9 D		<b>F8-5481</b>		Outer Thread [mm]=M10
Belt Pulley, crankshaft	1.9 D		<b>F8-5645</b>		
Top Strut Mounting	1.2	; Type: S530	<b>F8-6331</b>		
Top Strut Mounting	1.4	; Type: S537	<b>F8-6379</b>		
Top Strut Mounting	1.9 D	; Type: S534, S531, S53J, S53K	<b>F8-6379</b>		
Stabiliser Mounting	All Models		<b>F8-6796</b>		d=18
Control Arm-/Trailing Arm Bush	All Models		<b>G9-569</b>		H=46; d=12; D1=45; D2=48
Bellow, steering	All Models	with clamps;	<b>LM-10001S</b>		d1=10; d2=30; L [mm]=158
Bellow, steering	All Models	with clamps;	<b>LM-10002S</b>		d1=10; d2=40; L [mm]=160
Bellow, steering	All Models	with clamps;	<b>LM-10042S</b>		d1=10; d2=27.5; L [mm]=155
Bellow Set, drive shaft	All Models		<b>M-850850</b>		H=120; d1=28; d2=75.5
Bellow Set, drive shaft	All Models		<b>M-860860</b>		H=80; d2=85; D1=25.8
Bellow Set, drive shaft	1.2, 1.9 D		<b>M-870870</b>		
Bellow Set, drive shaft	All Models		<b>MK-850850</b>		
<b>19 Mk II (B/C53_)</b>			<b>01/1992 → 12/1995</b>		
Dust Cover Kit, shock absorber	1.2, 1.4, 1.7, 1.8, 1.8 16V, 1.9 D, 1.9 dT		<b>AK-735042</b>		
Anti-Friction Bearing	1.2, 1.4, 1.7, 1.8, 1.8 16V, 1.9 D, 1.9 dT		<b>F8-3033</b>		H=20; d1=62; d2=64; D=100
Engine Mounting	1.4	; Type: B532	<b>F8-4109</b>		
Engine Mounting	1.7, 1.8		<b>F8-4109</b>		
Engine Mounting	1.8	Type: B53Y	<b>F8-4109</b>		
Engine Mounting	1.8 16V	; Type: B53D	<b>F8-4109</b>		
Engine Mounting	1.8		<b>F8-4110</b>		d=12; D=99; T [mm]=119
Stabiliser Mounting	1.8, 1.9 dT		<b>F8-5085</b>		d=23

<b>AK-735042</b>	<b>F8-3033</b>	<b>F8-4109</b>	<b>F8-4110</b>	<b>F8-5085</b>	<b>F8-5349</b>	<b>F8-5481</b>
Ref.Nr.: 7700776743	Ref.Nr.: 7700797666	Ref.Nr.: 7700785949	Ref.Nr.: 7700805733	Ref.Nr.: 7700785788	Ref.Nr.: 7700800522	Ref.Nr.: 7700802927
<b>F8-5645</b>	<b>F8-6331</b>	<b>F8-6379</b>	<b>F8-6796</b>	<b>G9-569</b>	<b>LM-10001S</b>	<b>LM-10002S</b>
Ref.Nr.: 7700724249	Ref.Nr.: 7700793723	Ref.Nr.: 7700797654	Ref.Nr.: 7700784170	Ref.Nr.: 7700789478	Ref.Nr.: 7700678649	Ref.Nr.: 7700706007
<b>LM-10042S</b>	<b>M-850850</b>	<b>M-860860</b>	<b>M-870870</b>	<b>MK-850850</b>	<b>MK-860860</b>	<b>MK-870870</b>
Ref.Nr.: 7701469497	Ref.Nr.: 329373	Ref.Nr.: 7701462308	Ref.Nr.: 7701450617	Ref.Nr.: 329373	Ref.Nr.: 7701462100	Ref.Nr.: 7701450617

Article Description



Article Nr.

Fitting Position



**19 Mk II (B/C53)**

01/1992 → 12/1995

Engine Mounting	1.9 D , 1.9 dT		<b>F8-5349</b>		
Top Strut Mounting	1.4 , 1.7 , 1.8 , 1.9 D , 1.9 dT		<b>F8-5473</b>		
Engine Mounting	1.9 D , 1.9 dT		<b>F8-5481</b>		Outer Thread [mm]=M10
Engine Mounting	1.4	; Type: B532	<b>F8-5482</b>		
Engine Mounting	1.7 , 1.8 , 1.8 16V		<b>F8-5482</b>		
Engine Mounting	1.8		<b>F8-5482</b>		
Mounting, automatic transmission	1.7	05/1992 →; ; Type: B53B	<b>F8-5485</b>		
Mounting, automatic transmission	1.8	01/1987 →;	<b>F8-5485</b>		
Mounting, automatic transmission	1.8 , 1.9 D		<b>F8-5485</b>		
Mounting, automatic transmission	1.8 16V	03/1986 →; ;  4-speed	<b>F8-5485</b>		
Mounting, automatic transmission	1.9 dT	03/1986 →;	<b>F8-5485</b>		
Engine Mounting	1.9 D , 1.9 dT		<b>F8-5536</b>		
Belt Pulley , crankshaft	1.9 D , 1.9 dT		<b>F8-5645</b>		
Top Strut Mounting	1.8 16V		<b>F8-5850</b>		
Repair Set, axle beam	1.2, 1.4 , 1.7 , 1.9 D		<b>F8-6097</b>		
Top Strut Mounting	1.2	; Type: B530, B53W	<b>F8-6331</b>		
Top Strut Mounting	1.4		<b>F8-6331</b>		
Top Strut Mounting	1.4	; Type: B531, C531	<b>F8-6331</b>		
Top Strut Mounting	1.2, 1.4 , 1.7, 1.8 16V		<b>F8-6379</b>		
Top Strut Mounting	1.4	; Type: B537, B53A, B53G, B53H	<b>F8-6379</b>		
Top Strut Mounting	1.7	; Type: B533, B536, B53B, B53E, B53M	<b>F8-6379</b>		
Top Strut Mounting	1.7	; Type: B53B, B53F	<b>F8-6379</b>		
Top Strut Mounting	1.8	; Type: B538, B53V, B53Y	<b>F8-6379</b>		
Top Strut Mounting	1.8	; Type: B538, B53V, B53Y, C538	<b>F8-6379</b>		
Top Strut Mounting	1.9 D , 1.9 dT	; Type: B534, B53I, B53J, B53K, B53T, B53Z	<b>F8-6379</b>		
Stabiliser Mounting	1.2, 1.4, 1.7 , 1.8 , 1.8 16V , 1.9 D , 1.9 dT		<b>F8-6796</b>		d=18
Bearing, drive shaft	1.4 , 1.9 D , 1.9 dT		<b>F8-7173</b>		d=25.8
Stabiliser Mounting	1.4 , 1.7 , 1.8 , 1.8 16V , 1.9 D , 1.9 dT		<b>F8-7942</b>		
Control Arm-/Trailing Arm Bush	1.2, 1.4, 1.7 , 1.8 , 1.9 D , 1.9 dT		<b>G9-569</b>		
Control Arm-/Trailing Arm Bush	1.8 16V		<b>G9-653</b>		

<b>F8-5349</b>	<b>F8-5473</b>	<b>F8-5481</b>	<b>F8-5482</b>	<b>F8-5485</b>	<b>F8-5536</b>	<b>F8-5645</b>
Ref.Nr.: 7700800522	Ref.Nr.: 7700780875	Ref.Nr.: 7700802927	Ref.Nr.: 7700794601	Ref.Nr.: 7700788318	Ref.Nr.: 7700411638	Ref.Nr.: 7700724249
<b>F8-5850</b>	<b>F8-6097</b>	<b>F8-6331</b>	<b>F8-6379</b>	<b>F8-6796</b>	<b>F8-7173</b>	<b>F8-7942</b>
Ref.Nr.: 7700840234	Ref.Nr.: 7701464321	Ref.Nr.: 7700793723	Ref.Nr.: 7700797654	Ref.Nr.: 7700784170	Ref.Nr.: 7664079	Ref.Nr.: 7700784171
<b>G9-569</b>	<b>G9-653</b>	<b>LM-10001S</b>				
Ref.Nr.: 7700789478	Ref.Nr.: 7700789477	Ref.Nr.: 7700678649				

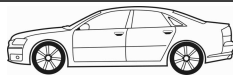
**Article Description****Article Nr.****Fitting Position**

<b>19 Mk II (B/C53_)</b>			<b>01/1992 → 12/1995</b>		
Bellow, steering	1.2, 1.4, 1.7, 1.8, 1.8 16V, 1.9 D, 1.9 dT	with clamps;	<b>LM-10001S</b>		d1=10; d2=30; L [mm]=158
Bellow, steering	1.2, 1.4, 1.7, 1.8, 1.8 16V, 1.9 D, 1.9 dT	with clamps;	<b>LM-10002S</b>		d1=10; d2=40; L [mm]=160
Bellow, steering	1.2, 1.4, 1.7, 1.8, 1.8 16V, 1.9 D, 1.9 dT	with clamps;	<b>LM-10042S</b>		d1=10; d2=27.5; L [mm]=155
Bellow Set, drive shaft	1.2, 1.4, 1.7, 1.8, 1.9 D, 1.9 dT		<b>M-850850</b>		H=120; d1=28; d2=75.5
Bellow Set, drive shaft	1.2, 1.4, 1.7, 1.8, 1.8 16V, 1.9 D, 1.9 dT		<b>M-860860</b>		H=80; d2=85; D1=25.8
Bellow Set, drive shaft	1.2, 1.4, 1.7, 1.8, 1.9 D		<b>M-870870</b>		
Bellow Set, drive shaft	1.2, 1.4, 1.7, 1.8, 1.9 D, 1.9 dT		<b>MK-850850</b>		
Bellow Set, drive shaft	1.4, 1.7, 1.8		<b>MK-860860</b>		D1=25.8; D2113.5; L=88
Bellow Set, drive shaft	1.8		<b>MK-870870</b>		
<b>19 Mk II Convertible (D53_, 853_)</b>			<b>04/1992 → 06/1996</b>		
Dust Cover Kit, shock absorber	1.7, 1.8, 1.8 16V		<b>AK-735042</b>		
Anti-Friction Bearing	1.7, 1.8, 1.8 16V		<b>F8-3033</b>		H=20; d1=62; d2=64; D=100
Engine Mounting	1.8	10/1994 →	<b>F8-4109</b>		
Engine Mounting	1.8 16V	11/1995 →	<b>F8-4109</b>		
Engine Mounting	1.7, 1.8, 1.8 16V		<b>F8-4110</b>		d=12; D=99; T [mm]=119
Stabiliser Mounting	1.7, 1.8, 1.8 16V		<b>F8-5085</b>		d=23
Top Strut Mounting	1.7, 1.8, 1.8 16V		<b>F8-5473</b>		
Engine Mounting	1.7, 1.8, 1.8 16V		<b>F8-5482</b>		
Mounting, automatic transmission	1.7, 1.8, 1.8 16V		<b>F8-5485</b>		
Mounting, automatic transmission	1.8	03/1986 →;  4-speed	<b>F8-5485</b>		
Top Strut Mounting	1.7, 1.8, 1.8 16V		<b>F8-6379</b>		
Top Strut Mounting	1.8	; Type: 853F, D53V	<b>F8-6379</b>		
Stabiliser Mounting	1.7, 1.8, 1.8 16V		<b>F8-6796</b>		d=18
Stabiliser Mounting	1.7, 1.8, 1.8 16V		<b>F8-7942</b>		
Control Arm-/Trailing Arm Bush	1.7, 1.8		<b>G9-569</b>		H=46; d=12; D1=45; D2=48
Control Arm-/Trailing Arm Bush	1.8 16V		<b>G9-653</b>		H1=35; H2=46; d=12; D=45
Bellow, steering	1.7, 1.8, 1.8 16V	with clamps;	<b>LM-10001S</b>		d1=10; d2=30; L [mm]=158
Bellow, steering	1.7, 1.8, 1.8 16V	with clamps;	<b>LM-10002S</b>		d1=10; d2=40; L [mm]=160
Bellow, steering	1.7, 1.8, 1.8 16V	with clamps;	<b>LM-10042S</b>		d1=10; d2=27.5; L [mm]=155
Bellow Set, drive shaft	1.7, 1.8		<b>M-850850</b>		H=120; d1=28; d2=75.5
Bellow Set, drive shaft	1.7, 1.8, 1.8 16V		<b>M-860860</b>		H=80; d2=85; D1=25.8
Bellow Set, drive shaft	1.7, 1.8		<b>MK-850850</b>		

<b>AK-735042</b>	<b>F8-3033</b>	<b>F8-4109</b>	<b>F8-4110</b>	<b>F8-5085</b>	<b>F8-5473</b>	<b>F8-5482</b>
Ref.Nr.: 7700776743	Ref.Nr.: 7700797666	Ref.Nr.: 7700785949	Ref.Nr.: 7700805733	Ref.Nr.: 7700785788	Ref.Nr.: 7700780875	Ref.Nr.: 7700794601
<b>F8-5485</b>	<b>F8-6379</b>	<b>F8-6796</b>	<b>F8-7942</b>	<b>G9-569</b>	<b>G9-653</b>	<b>LM-10001S</b>
Ref.Nr.: 7700788318	Ref.Nr.: 7700797654	Ref.Nr.: 7700784170	Ref.Nr.: 7700784171	Ref.Nr.: 7700789478	Ref.Nr.: 7700789477	Ref.Nr.: 7700678649
<b>LM-10002S</b>	<b>LM-10042S</b>	<b>M-850850</b>	<b>M-860860</b>	<b>M-870870</b>	<b>MK-850850</b>	<b>MK-860860</b>
Ref.Nr.: 7700706007	Ref.Nr.: 7701469497	Ref.Nr.: 329373	Ref.Nr.: 7701462308	Ref.Nr.: 7701450617	Ref.Nr.: 329373	Ref.Nr.: 7701462100

Article Description



Article Nr.

Fitting Position



19 Mk II Convertible (D53_, 853_)			04/1992 → 06/1996	
Bellow Set, drive shaft	1.7, 1.8		MK-860860	D1=25.8; D2113.5; L=88
19 Mk II Saloon (L53_)			04/1992 → 12/1995	
Dust Cover Kit, shock absorber	1.4, 1.7, 1.8, 1.8 16V, 1.9 D, 1.9 dT		AK-735042	
Anti-Friction Bearing	1.2, 1.4, 1.7, 1.8, 1.8 16V, 1.9 D, 1.9 dT		F8-3033	H=20; d1=62; d2=64; D=100
Engine Mounting	1.7, 1.8		F8-4109	
Engine Mounting	1.8 16V	10/1994 →	F8-4109	
Engine Mounting	1.8		F8-4110	d=12; D=99; T [mm]=119
Stabiliser Mounting	1.8, 1.9 dT		F8-5085	d=23
Engine Mounting	1.9 dT		F8-5349	
Top Strut Mounting	1.4, 1.7, 1.8, 1.9 D, 1.9 dT		F8-5473	
Engine Mounting	1.9 D, 1.9 dT		F8-5481	Outer Thread [mm]=M10
Engine Mounting	1.7, 1.8, 1.8 16V		F8-5482	
Engine Mounting	1.8		F8-5482	
Mounting, automatic transmission	1.7	10/1994 →;	F8-5485	
Mounting, automatic transmission	1.8	03/1986 →;	F8-5485	
Mounting, automatic transmission	1.8	09/1989 →;	F8-5485	
Mounting, automatic transmission	1.8, 1.8 16V	03/1986 →;	F8-5485	
Mounting, automatic transmission	1.9 dT		F8-5485	
Engine Mounting	1.9 dT		F8-5536	
Belt Pulley, crankshaft	1.9 D, 1.9 dT		F8-5645	
Top Strut Mounting	1.8 16V		F8-5850	
Repair Set, axle beam	1.2, 1.4, 1.7, 1.9 D		F8-6097	
Top Strut Mounting	1.4	⊗; Type: L531, L532	F8-6331	
Top Strut Mounting	1.2, 1.4, 1.7, 1.8, 1.8 16V, 1.9 D	⊗	F8-6379	
Top Strut Mounting	1.8	⊗; Type: L538, L53V	F8-6379	
Top Strut Mounting	1.9 dT	⊗; Type: B534, B531, B53J, B53K, B53T, B53Z	F8-6379	
Stabiliser Mounting	1.4, 1.7, 1.8, 1.8 16V, 1.9 D, 1.9 dT		F8-6796	d=18
Bearing, drive shaft	1.4, 1.9 D, 1.9 dT		F8-7173	d=25.8
Stabiliser Mounting	1.4, 1.7, 1.8, 1.8 16V, 1.9 D, 1.9 dT		F8-7942	
Control Arm-/Trailing Arm Bush	1.4, 1.7, 1.8, 1.9 D, 1.9 dT		G9-569	H=46; d=12; D1=45; D2=48

AK-735042	F8-3033	F8-4109	F8-4110	F8-5085	F8-5349	F8-5473
Ref.Nr.: 7700776743	Ref.Nr.: 7700797666	Ref.Nr.: 7700785949	Ref.Nr.: 7700805733	Ref.Nr.: 7700785788	Ref.Nr.: 7700800522	Ref.Nr.: 7700780875
F8-5481	F8-5482	F8-5485	F8-5536	F8-5645	F8-5850	F8-6097
Ref.Nr.: 7700802927	Ref.Nr.: 7700794601	Ref.Nr.: 7700788318	Ref.Nr.: 7700411638	Ref.Nr.: 7700724249	Ref.Nr.: 7700840234	Ref.Nr.: 7701464321
F8-6331	F8-6379	F8-6796	F8-7173	F8-7942	G9-569	G9-653
Ref.Nr.: 7700793723	Ref.Nr.: 7700797654	Ref.Nr.: 7700784170	Ref.Nr.: 7664079	Ref.Nr.: 7700784171	Ref.Nr.: 7700789478	Ref.Nr.: 7700789477

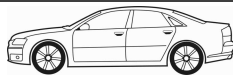
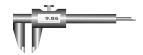
**Article Description****Article Nr.****Fitting Position**

<b>19 Mk II Saloon (L53_)</b>			<b>04/1992 → 12/1995</b>	
Control Arm-/Trailing Arm Bush	1.8 16V		<b>G9-653</b>	
Bellow, steering	1.4, 1.7, 1.8, 1.8 16V, 1.9 D, 1.9 dT	with clamps;	<b>LM-10001S</b>	
Bellow, steering	1.4, 1.7, 1.8, 1.8 16V, 1.9 D, 1.9 dT	with clamps;	<b>LM-10002S</b>	
Bellow, steering	1.4, 1.7, 1.8, 1.8 16V, 1.9 D, 1.9 dT	with clamps;	<b>LM-10042S</b>	
Bellow Set, drive shaft	1.4, 1.7, 1.8, 1.9 D, 1.9 dT		<b>M-850850</b>	
Bellow Set, drive shaft	1.4, 1.7, 1.8, 1.8 16V, 1.9 D, 1.9 dT		<b>M-860860</b>	
Bellow Set, drive shaft	1.4, 1.7, 1.8, 1.9 dT		<b>M-870870</b>	
Bellow Set, drive shaft	1.4, 1.7, 1.8, 1.9 D, 1.9 dT		<b>MK-850850</b>	
Bellow Set, drive shaft	1.4, 1.7, 1.8		<b>MK-860860</b>	
Bellow Set, drive shaft	1.8		<b>MK-870870</b>	
<b>19 Mk II Box (S53_)</b>			<b>03/1992 → 12/1995</b>	
Dust Cover Kit, shock absorber	All Models		<b>AK-735042</b>	
Anti-Friction Bearing	All Models		<b>F8-3033</b>	
Top Strut Mounting	All Models		<b>F8-5473</b>	
Engine Mounting	1.9 D, 1.9 dT		<b>F8-5481</b>	
Belt Pulley, crankshaft	1.9 D, 1.9 dT		<b>F8-5645</b>	
Top Strut Mounting	1.2	; Type: S530	<b>F8-6331</b>	
Top Strut Mounting	1.4	; Type: S537	<b>F8-6379</b>	
Top Strut Mounting	1.9 D, 1.9 dT	; Type: S534, S53I, S53J, S53K	<b>F8-6379</b>	
Stabiliser Mounting	All Models		<b>F8-6796</b>	
Bearing, drive shaft	1.9 dT		<b>F8-7173</b>	
Control Arm-/Trailing Arm Bush	All Models		<b>G9-569</b>	
Bellow, steering	All Models	with clamps;	<b>LM-10001S</b>	
Bellow, steering	All Models	with clamps;	<b>LM-10002S</b>	
Bellow, steering	All Models	with clamps;	<b>LM-10042S</b>	
Bellow Set, drive shaft	All Models		<b>M-850850</b>	
Bellow Set, drive shaft	All Models		<b>M-860860</b>	
Bellow Set, drive shaft	1.2, 1.9 D		<b>M-870870</b>	
Bellow Set, drive shaft	All Models		<b>MK-850850</b>	
<b>20 (127_)</b>			<b>10/1975 → 12/1983</b>	
Bellow Set, drive shaft	1.6	ch. → 187000;	<b>MK-850850</b>	
Bellow Set, drive shaft	1.6		<b>MK-850850</b>	

<b>AK-735042</b>	<b>F8-3033</b>	<b>F8-5473</b>	<b>F8-5481</b>	<b>F8-5645</b>	<b>F8-6331</b>	<b>F8-6379</b>
Ref.Nr.: 7700776743	Ref.Nr.: 7700797666	Ref.Nr.: 7700780875	Ref.Nr.: 7700802927	Ref.Nr.: 7700724249	Ref.Nr.: 7700793723	Ref.Nr.: 7700797654
<b>F8-6796</b>	<b>F8-7173</b>	<b>G9-569</b>	<b>G9-653</b>	<b>LM-10001S</b>	<b>LM-10002S</b>	<b>LM-10042S</b>
Ref.Nr.: 7700784170	Ref.Nr.: 7664079	Ref.Nr.: 7700789478	Ref.Nr.: 7700789477	Ref.Nr.: 7700678649	Ref.Nr.: 7700706007	Ref.Nr.: 7701469497
<b>M-850850</b>	<b>M-860860</b>	<b>M-870870</b>	<b>MK-850850</b>	<b>MK-860860</b>	<b>MK-870870</b>	
Ref.Nr.: 329373	Ref.Nr.: 7701462308	Ref.Nr.: 7701450617	Ref.Nr.: 329373	Ref.Nr.: 7701462100	Ref.Nr.: 7701450617	

Article Description

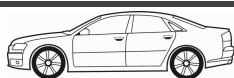

Article Nr.

Fitting Position



21 (B48_)			07/1989 → 06/1994		
Anti-Friction Bearing	All Models		F8-3033		H=20; d1=62; d2=64; D=100
Mounting, automatic transmission	1.7	4-speed	F8-5485		
Top Strut Mounting	1.7, 1.9 D, 2.0, 2.0 4x4, 2.1 D, 2.1 Turbo-D, 2.2		F8-5499		
Belt Pulley, crankshaft	1.9 D		F8-5645		
Control Arm-/Trailing Arm Bush	All Models		F8-5785		H=49; d=12
Control Arm-/Trailing Arm Bush	1.4, 1.7, 1.9 D		F8-5786		H=49; d=12
Mounting, axle beam	1.4, 1.7, 1.9 D, 2.0, 2.0 TXi, 2.1 D, 2.1 Turbo-D, 2.2		F8-6079		H1=73; H2=37; d=32; D1=72; D2=40
Top Strut Mounting	1.4, 1.7, 1.9 D, 2.0, 2.1 D		F8-6222		
Stabiliser Mounting	2.0, 2.1 D, 2.1 Turbo-D, 2.2		F8-6788		d=23
Stabiliser Mounting	2.0, 2.0 4x4, 2.1 D, 2.1 Turbo-D, 2.2, 2.2 4x4		F8-6790		d=24
Stabiliser Mounting	1.9 D, 2.1 D, 2.1 Turbo-D		F8-6797		
Stabiliser Mounting	1.7, 1.9 D		F8-6799		d=23
Control Arm-/Trailing Arm Bush	2.0		F8-6802		
Control Arm-/Trailing Arm Bush	2.1 D	Type: B48V	F8-6802		
Control Arm-/Trailing Arm Bush	2.1 Turbo-D	Type: B488	F8-6802		
Engine Mounting	2.0, 2.2		F8-6863		
Engine Mounting	2.1 D	Type: B48V	F8-6863		
Engine Mounting	2.1 Turbo-D	Type: B488	F8-6863		
Engine Mounting	1.7		F8-6865		
Engine Mounting	1.7		F8-6871		
Engine Mounting	2.0, 2.0 4x4, 2.1 Turbo-D		F8-6908		
Engine Mounting	2.0, 2.2, 2.2 4x4		F8-6908		
Engine Mounting	2.1 D	Type: B48V	F8-6908		
Engine Mounting	2.0, 2.0 4x4, 2.1 Turbo-D		F8-6909		
Engine Mounting	2.0, 2.2, 2.2 4x4		F8-6909		
Engine Mounting	2.1 D	Type: B48V	F8-6909		
Mounting, axle bracket	2.0, 2.0 4x4, 2.2, 2.2 4x4		F8-7044		
Mounting, axle bracket	2.1 D	Type: B48V	F8-7044		
Mounting, axle bracket	2.1 Turbo-D	Type: B488	F8-7044		
Belt Pulley, crankshaft	2.1 D, 2.1 Turbo-D	Number of Ribs: 2;	F8-7091		Belt Pulley Ø [mm]=142; Mounting points diam.[mm]=15; W=38

<b>F8-3033</b>	<b>F8-5485</b>	<b>F8-5499</b>	<b>F8-5645</b>	<b>F8-5785</b>	<b>F8-5786</b>	<b>F8-6079</b>
Ref.Nr.: 7700797666	Ref.Nr.: 7700788318	Ref.Nr.: 7700766389	Ref.Nr.: 7700724249	Ref.Nr.: 7700767684	Ref.Nr.: 7700767685	Ref.Nr.: 95FB-5C485-AA
<b>F8-6222</b>	<b>F8-6788</b>	<b>F8-6790</b>	<b>F8-6797</b>	<b>F8-6799</b>	<b>F8-6802</b>	<b>F8-6863</b>
Ref.Nr.: 7700803635	Ref.Nr.: 7700771562	Ref.Nr.: 7700774026	Ref.Nr.: 7700769226	Ref.Nr.: 7700773245	Ref.Nr.: 7700777276	Ref.Nr.: 7700766126
<b>F8-6865</b>	<b>F8-6871</b>	<b>F8-6908</b>	<b>F8-6909</b>	<b>F8-7044</b>	<b>F8-7091</b>	<b>F8-7173</b>
Ref.Nr.: 7700765935	Ref.Nr.: 7700763207	Ref.Nr.: 7700769720	Ref.Nr.: 7700769719	Ref.Nr.: 7700767686	Ref.Nr.: 7700853470	Ref.Nr.: 7664079



**Article Description****Article Nr.****Fitting Position**

<b>21 (B48_)</b>				<b>07/1989 → 06/1994</b>	
Bearing, drive shaft	1.7			<b>F8-7173</b>	d=25.8
Control Arm-/Trailing Arm Bush	1.7, 2.0, 2.0 4x4, 2.2, 2.2 4x4			<b>G9-570</b>	H1=35; H2=46; d=12; D=32
Control Arm-/Trailing Arm Bush	1.9 D, 2.1 D, 2.1 Turbo-D			<b>G9-571</b>	d=12; D=36; Thick. [mm]=39, 51
Control Arm-/Trailing Arm Bush	1.9 D, 2.1 D, 2.1 Turbo-D			<b>G9-598</b>	H1=37; H2=49; d=12; D=36
Bellow, steering	1.4, 1.7	with clamps; ☉		<b>LM-10002S</b>	d1=10; d2=40; L [mm]=160
Bellow Set, drive shaft	1.7, 1.9 D			<b>M-850850</b>	H=120; d1=28; d2=75.5
Bellow Set, drive shaft	1.7, 1.9 D	☉		<b>MK-850850</b>	
<b>21 Box (S48_)</b>				<b>06/1986 → 04/1995</b>	
Anti-Friction Bearing	All Models			<b>F8-3033</b>	H=20; d1=62; d2=64; D=100
Top Strut Mounting	All Models	☉, ☉		<b>F8-5499</b>	
Belt Pulley, crankshaft	1.9 D			<b>F8-5645</b>	
Control Arm-/Trailing Arm Bush	All Models			<b>F8-5785</b>	H=49; d=12
Control Arm-/Trailing Arm Bush	1.7			<b>F8-5786</b>	H=49; d=12
Mounting, axle beam	All Models			<b>F8-6079</b>	H1=73; H2=37; d=32; D1=72; D2=40
Top Strut Mounting	2.1 D	☉, ☉		<b>F8-6222</b>	
Stabiliser Mounting	2.1 D			<b>F8-6790</b>	d=24
Stabiliser Mounting	1.9 D, 2.1 D			<b>F8-6797</b>	
Stabiliser Mounting	1.7			<b>F8-6799</b>	d=23
Control Arm-/Trailing Arm Bush	1.7			<b>G9-570</b>	H1=35; H2=46; d=12; D=32
Control Arm-/Trailing Arm Bush	1.9 D, 2.1 D			<b>G9-571</b>	d=12; D=36; Thick. [mm]=39, 51
Control Arm-/Trailing Arm Bush	1.9 D, 2.1 D			<b>G9-598</b>	H1=37; H2=49; d=12; D=36
Bellow, steering	1.7	with clamps; ☉		<b>LM-10002S</b>	d1=10; d2=40; L [mm]=160
Bellow Set, drive shaft	1.7, 1.9 D			<b>M-850850</b>	H=120; d1=28; d2=75.5
Bellow Set, drive shaft	1.7, 1.9 D	☉		<b>MK-850850</b>	
<b>21 Savanna (K48_)</b>				<b>03/1986 → 09/1995</b>	
Anti-Friction Bearing	All Models			<b>F8-3033</b>	H=20; d1=62; d2=64; D=100
Mounting, automatic transmission	1.7	01/1987 →; ☉		<b>F8-5485</b>	
Mounting, automatic transmission	1.7	☉		<b>F8-5485</b>	

<b>F8-3033</b>	<b>F8-5485</b>	<b>F8-5499</b>	<b>F8-5645</b>	<b>F8-5785</b>	<b>F8-5786</b>	<b>F8-6079</b>
Ref.Nr.: 7700797666	Ref.Nr.: 7700788318	Ref.Nr.: 7700766389	Ref.Nr.: 7700724249	Ref.Nr.: 7700767684	Ref.Nr.: 7700767685	Ref.Nr.: 95FB-5C485-AA
<b>F8-6222</b>	<b>F8-6790</b>	<b>F8-6797</b>	<b>F8-6799</b>	<b>F8-7173</b>	<b>G9-570</b>	<b>G9-571</b>
Ref.Nr.: 7700803635	Ref.Nr.: 7700774026	Ref.Nr.: 7700769226	Ref.Nr.: 7700773245	Ref.Nr.: 7664079	Ref.Nr.: 7700762574	Ref.Nr.: 7700745515
<b>G9-598</b>	<b>LM-10002S</b>	<b>M-850850</b>	<b>MK-850850</b>			
Ref.Nr.: 7700772687	Ref.Nr.: 7700706007	Ref.Nr.: 329373	Ref.Nr.: 329373			

Article Description



Article Nr.

Fitting Position



**21 Savanna (K48\_)**

03/1986 → 09/1995

Mounting, automatic transmission	1.7	4-speed	F8-5485	⊕	
Top Strut Mounting	1.7, 1.9 D, 2.0, 2.0 4x4, 2.1 D, 2.1 D 4x4, 2.1 Turbo-D, 2.2 4x4	⊕; ⊕	F8-5499	⊕ ⊕ ⊕	
Top Strut Mounting	1.7, 2.1 D	01/1987 →; ⊕; ⊕	F8-5499	⊕ ⊕ ⊕	
Top Strut Mounting	2.0, 2.2	⊕; ⊕; ⊕	F8-5499	⊕ ⊕ ⊕	
Belt Pulley, crankshaft	1.9 D		F8-5645		
Control Arm-/Trailing Arm Bush	1.7, 1.9 D, 2.0, 2.0 4x4, 2.1 D, 2.1 D 4x4, 2.1 Turbo-D, 2.2, 2.2 4x4		F8-5785	⊕ ⊕ ⊕	H=49; d=12
Control Arm-/Trailing Arm Bush	1.7, 1.9 D		F8-5786	⊕ ⊕ ⊕	H=49; d=12
Mounting, axle beam	1.7, 1.9 D, 2.0, 2.0 4x4, 2.1 D, 2.1 D 4x4, 2.1 Turbo-D, 2.2, 2.2 4x4		F8-6079	⊕ ⊕ ⊕	H1=73; H2=37; d=32; D1=72; D2=40
Top Strut Mounting	1.7, 1.9 D, 2.0, 2.0 4x4, 2.1 D, 2.1 D 4x4, 2.1 Turbo-D, 2.2	⊕; ⊕	F8-6222	⊕ ⊕ ⊕	
Stabiliser Mounting	2.0, 2.1 D, 2.1 Turbo-D, 2.2		F8-6788	⊕	d=23
Stabiliser Mounting	2.0, 2.0 4x4, 2.1 D, 2.1 D 4x4, 2.1 Turbo-D, 2.2, 2.2 4x4		F8-6790	⊕	d=24
Stabiliser Mounting	1.9 D, 2.1 D, 2.1 D 4x4, 2.1 Turbo-D		F8-6797	⊕	
Stabiliser Mounting	1.7		F8-6799	⊕	d=23
Control Arm-/Trailing Arm Bush	2.0, 2.1 D, 2.2		F8-6802	⊕	
Control Arm-/Trailing Arm Bush	2.1 D	Type: K48V, S48V	F8-6802	⊕	
Control Arm-/Trailing Arm Bush	2.1 Turbo-D	Type: K488	F8-6802	⊕	
Engine Mounting	1.7	⊕	F8-6842	⊕ ↑	
Engine Mounting	2.0, 2.2		F8-6863	⊕ ⊕	
Engine Mounting	2.1 D	Type: K486	F8-6863	⊕ ⊕	
Engine Mounting	2.1 D	Type: K48V, S48V	F8-6863	⊕ ⊕	
Engine Mounting	2.1 Turbo-D	Type: K487, K488	F8-6863	⊕ ⊕	
Engine Mounting	1.7		F8-6865		
Engine Mounting	1.7	04/1988 →	F8-6865		
Engine Mounting	1.7	⊕	F8-6865		
Engine Mounting	1.7		F8-6871	⊕	
Engine Mounting	1.7	04/1988 →	F8-6871	⊕	
Engine Mounting	1.7	⊕	F8-6871	⊕	
Engine Mounting	2.0, 2.1 D, 2.1 D 4x4, 2.1 Turbo-D		F8-6908	⊕	
Engine Mounting	2.0, 2.2, 2.2 4x4	⊕	F8-6908	⊕	



**Article Description****Article Nr.****Fitting Position**

<b>21 Savanna (K48)</b>				<b>03/1986 → 09/1995</b>	
Engine Mounting	2.1 D	Type: K48V, S48V	<b>F8-6908</b>		
Engine Mounting	2.0, 2.1 D, 2.1 D 4x4, 2.1 Turbo-D		<b>F8-6909</b>		
Engine Mounting	2.0, 2.2, 2.2 4x4		<b>F8-6909</b>		
Engine Mounting	2.1 D	Type: K48V, S48V	<b>F8-6909</b>		
Mounting, axle bracket	2.0, 2.1 D, 2.1 D 4x4, 2.2, 2.2 4x4		<b>F8-7044</b>		
Mounting, axle bracket	2.1 D	Type: K48O, K48V, S48V	<b>F8-7044</b>		
Mounting, axle bracket	2.1 Turbo-D	Type: K487, K488	<b>F8-7044</b>		
Belt Pulley, crankshaft	2.1 D, 2.1 D 4x4, 2.1 Turbo-D	Number of Ribs: 2	<b>F8-7091</b>		Belt Pulley Ø [mm]=142; Mounting points diam.[mm]=15; W=38
Bearing, drive shaft	1.7		<b>F8-7173</b>		d=25.8
Control Arm-/Trailing Arm Bush	1.7, 2.0, 2.0 4x4, 2.1 D, 2.2, 2.2 4x4		<b>G9-570</b>		H1=35; H2=46; d=12; D=32
Control Arm-/Trailing Arm Bush	1.9 D, 2.1 D, 2.1 D 4x4, 2.1 Turbo-D		<b>G9-571</b>		d=12; D=36; Thick. [mm]=39, 51
Control Arm-/Trailing Arm Bush	1.9 D, 2.1 D, 2.1 D 4x4, 2.1 Turbo-D		<b>G9-598</b>		H1=37; H2=49; d=12; D=36
Bellow, steering	1.7	with clamps;	<b>LM-10001S</b>		d1=10; d2=30; L [mm]=158
Bellow, steering	1.7	with clamps;	<b>LM-10002S</b>		d1=10; d2=40; L [mm]=160
Bellow, steering	1.7	with clamps;	<b>LM-10042S</b>		d1=10; d2=27.5; L [mm]=155
Bellow Set, drive shaft	1.7, 1.9 D		<b>M-850850</b>		H=120; d1=28; d2=75.5
Bellow Set, drive shaft	1.7, 1.9 D		<b>MK-850850</b>		
<b>21 Saloon (L48)</b>				<b>03/1986 → 06/1994</b>	
Anti-Friction Bearing	1.4, 1.7, 1.9 D, 2.0, 2.0 4x4, 2.0 Turbo, 2.0 Turbo 4x4, 2.1 D, 2.1 TD, 2.1 Turbo-D, 2.2, 2.2 4x4		<b>F8-3033</b>		H=20; d1=62; d2=64; D=100
Mounting, automatic transmission	1.7	4-speed	<b>F8-5485</b>		
Top Strut Mounting	1.4, 1.7, 1.9 D, 2.0, 2.1 D, 2.2 4x4		<b>F8-5499</b>		
Top Strut Mounting	2.0, 2.1 D, 2.1 Turbo-D, 2.2		<b>F8-5499</b>		
Belt Pulley, crankshaft	1.9 D		<b>F8-5645</b>		
Control Arm-/Trailing Arm Bush	1.4, 1.7, 1.9 D, 2.0, 2.0 4x4, 2.0 Turbo, 2.0 Turbo 4x4, 2.1 D, 2.1 TD, 2.1 Turbo-D, 2.2, 2.2 4x4		<b>F8-5785</b>		H=49; d=12
Control Arm-/Trailing Arm Bush	1.4, 1.7, 1.9 D		<b>F8-5786</b>		H=49; d=12
Mounting, axle beam	1.4, 1.7, 1.9 D, 2.0, 2.0 Turbo, 2.0 Turbo 4x4, 2.1 D, 2.1 TD, 2.1 Turbo-D, 2.2		<b>F8-6079</b>		H1=73; H2=37; d=32; D1=72; D2=40
Top Strut Mounting	1.4, 1.7, 1.9 D, 2.0, 2.0 4x4, 2.1 D, 2.1 Turbo-D, 2.2		<b>F8-6222</b>		
Stabiliser Mounting	2.0, 2.0 Turbo, 2.1 D, 2.1 Turbo-D, 2.2		<b>F8-6788</b>		d=23

<b>F8-3033</b>	<b>F8-5485</b>	<b>F8-5499</b>	<b>F8-5645</b>	<b>F8-5785</b>	<b>F8-5786</b>	<b>F8-6079</b>
Ref.Nr.: 7700797666	Ref.Nr.: 7700788318	Ref.Nr.: 7700766389	Ref.Nr.: 7700724249	Ref.Nr.: 7700767684	Ref.Nr.: 7700767685	Ref.Nr.: 95FB-5C485-AA
<b>F8-6222</b>	<b>F8-6788</b>	<b>F8-6790</b>	<b>F8-6908</b>	<b>F8-6909</b>	<b>F8-7044</b>	<b>F8-7091</b>
Ref.Nr.: 7700803635	Ref.Nr.: 7700771562	Ref.Nr.: 7700774026	Ref.Nr.: 7700769720	Ref.Nr.: 7700769719	Ref.Nr.: 7700767686	Ref.Nr.: 7700853470
<b>F8-7173</b>	<b>G9-570</b>	<b>G9-571</b>	<b>G9-598</b>	<b>LM-10001S</b>	<b>LM-10002S</b>	<b>LM-10042S</b>
Ref.Nr.: 7664079	Ref.Nr.: 7700762574	Ref.Nr.: 7700745515	Ref.Nr.: 7700772687	Ref.Nr.: 7700678649	Ref.Nr.: 7700706007	Ref.Nr.: 7701469497

Article Description



Article Nr.

Fitting Position



## 21 Saloon (L48\_)

03/1986 → 06/1994

Stabiliser Mounting	2.0, 2.0 4x4 , 2.0 Turbo , 2.0 Turbo 4x4, 2.1 D , 2.1 Turbo-D , 2.2 , 2.2 4x4		F8-6790		d=24
Stabiliser Mounting	1.9 D , 2.1 D , 2.1 Turbo-D		F8-6797		
Stabiliser Mounting	1.4 , 1.7 , 1.9 D		F8-6799		d=23
Engine Mounting	2.0	06/1986 →	F8-6863		
Engine Mounting	2.0 Turbo , 2.1 D , 2.2		F8-6863		
Engine Mounting	2.1 Turbo-D	04/1986 →; Type: L488	F8-6863		
Engine Mounting	1.7		F8-6865		
Engine Mounting	1.7	06/1988 →	F8-6865		
Engine Mounting	1.7		F8-6871		
Engine Mounting	1.7	06/1988 →	F8-6871		
Engine Mounting	1.7		F8-6871		
Engine Mounting	2.0		F8-6908		
Engine Mounting	2.0 , 2.0 4x4 , 2.0 Turbo , 2.0 Turbo 4x4 , 2.1 D , 2.1 Turbo-D		F8-6908		
Engine Mounting	2.0 , 2.2 , 2.2 4x4	not for transmission type: AR4	F8-6908		
Engine Mounting	2.1 D	Type: L48V	F8-6908		
Engine Mounting	2.0		F8-6909		
Engine Mounting	2.0 , 2.0 4x4 , 2.0 Turbo , 2.0 Turbo 4x4 , 2.1 D , 2.1 Turbo-D		F8-6909		
Engine Mounting	2.0 , 2.2 , 2.2 4x4	not for transmission type: AR4	F8-6909		
Engine Mounting	2.1 D	Type: L48V	F8-6909		
Mounting, axle bracket	2.0	06/1986 →	F8-7044		
Mounting, axle bracket	2.0 Turbo , 2.1 D , 2.2 , 2.2 4x4		F8-7044		
Mounting, axle bracket	2.1 Turbo-D	04/1986 →; Type: L488	F8-7044		
Belt Pulley, crankshaft	2.1 D	Number of Ribs: 2;	F8-7091		Belt Pulley Ø [mm]=142; Mounting points diam.[mm]=15; W=38
Belt Pulley, crankshaft	2.1 Turbo-D	07/1986 →; Number of Ribs: 2;	F8-7091		Belt Pulley Ø [mm]=142; Mounting points diam.[mm]=15; W=38
Bearing, drive shaft	1.7		F8-7173		d=25.8
Control Arm-/Trailing Arm Bush	1.4 , 1.7 , 2.0, 2.0 4x4 , 2.0 Turbo , 2.0 Turbo 4x4, 2.2 , 2.2 4x4		G9-570		H1=35; H2=46; d=12; D=32
Control Arm-/Trailing Arm Bush	1.9 D , 2.1 D , 2.1 Turbo-D		G9-571		d=12; D=36; Thick. [mm]=39, 51
Control Arm-/Trailing Arm Bush	1.9 D , 2.1 D , 2.1 Turbo-D		G9-598		H1=37; H2=49; d=12; D=36
Bellow, steering	1.4 , 1.7	with clamps;	LM-10001S		d1=10; d2=30; L [mm]=158

<b>F8-6790</b>	<b>F8-6797</b>	<b>F8-6799</b>	<b>F8-6863</b>	<b>F8-6865</b>	<b>F8-6871</b>	<b>F8-6908</b>
Ref.Nr.: 7700774026	Ref.Nr.: 7700769226	Ref.Nr.: 7700773245	Ref.Nr.: 7700766126	Ref.Nr.: 7700765935	Ref.Nr.: 7700763207	Ref.Nr.: 7700769720
<b>F8-6909</b>	<b>F8-7044</b>	<b>F8-7091</b>	<b>F8-7173</b>	<b>G9-570</b>	<b>G9-571</b>	<b>G9-598</b>
Ref.Nr.: 7700769719	Ref.Nr.: 7700767686	Ref.Nr.: 7700853470	Ref.Nr.: 7664079	Ref.Nr.: 7700762574	Ref.Nr.: 7700745515	Ref.Nr.: 7700772687
<b>LM-10001S</b>	<b>LM-10002S</b>					
Ref.Nr.: 7700678649	Ref.Nr.: 7700706007					

**Article Description****Article Nr.****Fitting Position****21 Saloon (L48\_)****03/1986 → 06/1994**

Bellow, steering	1.4, 1.7	with clamps;	<b>LM-10002S</b>		d1=10; d2=40; L [mm]=160
Bellow, steering	1.4, 1.7	with clamps;	<b>LM-10042S</b>		d1=10; d2=27.5; L [mm]=155
Bellow Set, drive shaft	1.4, 1.7, 1.9 D		<b>M-850850</b>		H=120; d1=28; d2=75.5
Bellow Set, drive shaft	1.4, 1.7, 1.9 D		<b>MK-850850</b>		

**25 (B29\_)****04/1984 → 12/1993**

Control Arm-Trailing Arm Bush	2.4 V6 Turbo , 2.8 V6 Injection		<b>F8-5111</b>		H=32; d=14; D=48
Control Arm-Trailing Arm Bush	2.0, 2.0 12V, 2.1 Diesel , 2.1 Turbo-D , 2.2, 2.4 V6 Turbo , 2.5 V6 Turbo , 2.7 V6 Injection , 2.8 V6 , 2.8 V6 Injection		<b>F8-6116</b>		d=22.5; L=63; D=55
Engine Mounting	2.0 12V	J7R 720, J7R 721;	<b>F8-6489</b>		
Engine Mounting	2.1 Diesel		<b>F8-6489</b>		
Engine Mounting	2.1 Turbo-D	06/1988 →;  J8S 708	<b>F8-6489</b>		
Engine Mounting	2.0 12V	J7R 720, J7R 721;	<b>F8-6504</b>		
Engine Mounting	2.1 Diesel		<b>F8-6504</b>		
Engine Mounting	2.1 Turbo-D	06/1988 →;  J8S 708	<b>F8-6504</b>		
Engine Mounting	2.4 V6 Turbo , 2.5 V6 Turbo , 2.8 V6 , 2.8 V6 Injection		<b>F8-6875</b>		
Engine Mounting	2.7 V6 Injection		<b>F8-6875</b>		
Belt Pulley, crankshaft	2.1 Diesel , 2.1 Turbo-D	Number of Ribs: 2	<b>F8-7091</b>		Belt Pulley Ø [mm]=142; Mounting points diam.[mm]=15; W=38
Bellow, steering	All Models	with clamps;	<b>LM-10002S</b>		d1=10; d2=40; L [mm]=160
Bellow Set, drive shaft	2.1 Diesel , 2.1 Turbo-D		<b>MK-850850</b>		

**AVANTIME (DE0\_)****09/2001 → 05/2003**

Anti-Friction Bearing	All Models		<b>F8-3012</b>		H=20; d=66; D=100
Top Strut Mounting	All Models		<b>F8-6333</b>		
Top Strut Mounting	All Models		<b>F8-7157</b>		
Control Arm-Trailing Arm Bush	All Models		<b>F8-7993</b>		
Bellow, steering	All Models	with clamps	<b>LM-10032S</b>		d1=9.5; d2=42; L [mm]=165

**CLIO (B/C57\_ , 5/357\_)****05/1990 → 09/1998**

Dust Cover Kit, shock absorber	1.1, 1.2, 1.4, 1.7, 1.8, 1.8 16V, 1.8 Rsi, 1.9 D, 1.9 D, Williams		<b>AK-735257</b>		
Anti-Friction Bearing	1.1, 1.2, 1.4, 1.7, 1.8, 1.8 16V, 1.8 Rsi, 1.9 D, 1.9 D, Electric, Williams		<b>F8-3032</b>		H=9; d1=16; d2=27; D=56
Stabiliser Mounting	1.2, 1.4, 1.8, 1.8 16V, 1.8 Rsi, 1.9 D		<b>F8-5085</b>		d=23
Stabiliser Set	1.1, 1.2, 1.4, 1.7, 1.8, 1.8 16V, 1.8 Rsi, 1.9 D, 1.9 D		<b>F8-5087</b>		
Stabiliser Mounting	1.2, 1.4, 1.8, 1.8 16V, 1.8 Rsi, 1.9 D, Williams		<b>F8-5088</b>		d=22

<b>AK-735257</b>	<b>F8-3012</b>	<b>F8-3032</b>	<b>F8-5085</b>	<b>F8-5087</b>	<b>F8-5088</b>	<b>F8-5090</b>
Ref.Nr.: 7700802667	Ref.Nr.: 503527	Ref.Nr.: 8200651172	Ref.Nr.: 7700785788	Ref.Nr.: 54616-00QAA	Ref.Nr.: 7700800976	Ref.Nr.: 7700760264
<b>F8-5111</b>	<b>F8-6116</b>	<b>F8-6333</b>	<b>F8-6489</b>	<b>F8-6504</b>	<b>F8-6875</b>	<b>F8-7091</b>
Ref.Nr.: 7700781463	Ref.Nr.: 7700781441	Ref.Nr.: 6025305979	Ref.Nr.: 77 00 783 018	Ref.Nr.: 77 00 759 732	Ref.Nr.: 6025102333	Ref.Nr.: 7700853470
<b>F8-7157</b>	<b>F8-7993</b>	<b>LM-10002S</b>	<b>LM-10032S</b>	<b>LM-10042S</b>	<b>M-850850</b>	<b>MK-850850</b>
Ref.Nr.: 6025305980	Ref.Nr.: 6025311529	Ref.Nr.: 7700706007	Ref.Nr.: 7701470361	Ref.Nr.: 7701469497	Ref.Nr.: 329373	Ref.Nr.: 329373

Article Description



Article Nr.

Fitting Position



CLIO (B/C57_, 5/357_)			05/1990 → 09/1998		
Stabiliser Mounting	Williams	Stabi. Diam. [mm]= 23	F8-5090		d=22
Control Arm-/Trailing Arm Bush	1.4, 1.8, 1.8 16V, 1.8 Rsi		F8-5125		H=46; d=12; D=40
Engine Mounting	1.2, 1.4, 1.8, 1.9 D		F8-5349		
Top Strut Mounting	1.1, 1.2, 1.4, 1.7, 1.8, 1.8 16V, 1.8 Rsi, 1.9 D, 1.9 D, Williams		F8-5389		
Engine Mounting	1.8, 1.8 16V		F8-5472		
Engine Mounting	Williams	Type: C57M	F8-5472		
Engine Mounting	1.2, 1.4, 1.8, 1.8 Rsi, 1.9 D		F8-5480		
Engine Mounting	1.8 Rsi	Type: C579	F8-5480		
Engine Mounting	1.1, 1.2, 1.4, 1.7, 1.8, 1.8 16V, 1.8 Rsi, 1.9 D, Williams		F8-5483		
Engine Mounting	1.2, 1.9 D		F8-5484		Outer Thread [mm]=M10
Spring Cap	1.1, 1.2, 1.4, 1.7, 1.8, 1.8 16V, 1.8 Rsi, 1.9 D, 1.9 D, Williams		F8-5488		
Top Strut Mounting	1.1, 1.2, 1.4, 1.7, 1.8, 1.8 16V, 1.8 Rsi, 1.9 D, 1.9 D, Electric, Williams		F8-5492		
Belt Pulley, crankshaft	1.9 D		F8-5645		
Top Strut Mounting	1.1, 1.2, 1.4, 1.7, 1.8, 1.8 16V, 1.8 Rsi, 1.9 D, 1.9 D, Williams		F8-5813		
Rubber Buffer, suspension	1.1, 1.2, 1.4, 1.7, 1.8, 1.9 D		F8-5863		
Repair Kit, wheel suspension	1.1	Type: B571	F8-6278		
Repair Kit, wheel suspension	1.2	Type: 357F, 357G, 357J, 357L, 557F, 557J, 557L, B57S, C57S	F8-6278		
Repair Kit, wheel suspension	1.2	Type: B577, C577	F8-6278		
Repair Kit, wheel suspension	1.2	Type: B57R, C57R	F8-6278		
Repair Kit, wheel suspension	1.2, 1.4, 1.7, 1.8	ABS	F8-6278		
Repair Kit, wheel suspension	1.4	ABS; Type: B57B, C57B	F8-6278		
Repair Kit, wheel suspension	1.8, 1.9 D	ABS; Type: 557_	F8-6278		
Repair Kit, wheel suspension	1.9 D	ABS; Type: B576, B57L, C576, C57L	F8-6278		
Repair Kit, suspension strut	1.1, 1.2, 1.4, 1.7, 1.8, 1.8 16V, 1.8 Rsi, 1.9 D, 1.9 D, Williams	with mounting parts;	F8-6376		
Engine Mounting	1.1		F8-6495		
Engine Mounting	1.2	Type: B577, C577	F8-6495		
Engine Mounting	1.9 D	F8Q 730	F8-6495		
Engine Mounting	1.8 16V		F8-6873		
Engine Mounting	Williams	Type: C57M	F8-6873		
Bearing, drive shaft	1.2, 1.4, 1.8, 1.8 16V, 1.8 Rsi, 1.9 D, 1.9 D, Williams		F8-7173		d=25.8

<b>F8-5090</b>	<b>F8-5125</b>	<b>F8-5349</b>	<b>F8-5389</b>	<b>F8-5472</b>	<b>F8-5480</b>	<b>F8-5483</b>
Ref.Nr.: 7700760264	Ref.Nr.: 7700799066	Ref.Nr.: 7700800522	Ref.Nr.: 7700827435	Ref.Nr.: 7700832262	Ref.Nr.: 7700805123	Ref.Nr.: 7700795689
<b>F8-5484</b>	<b>F8-5488</b>	<b>F8-5492</b>	<b>F8-5645</b>	<b>F8-5813</b>	<b>F8-5863</b>	<b>F8-6278</b>
Ref.Nr.: 7700795688	Ref.Nr.: 7700828866	Ref.Nr.: 7700827436	Ref.Nr.: 7700724249	Ref.Nr.: 7700800107	Ref.Nr.: 7700428440	Ref.Nr.: 7701464320
<b>F8-6376</b>	<b>F8-6495</b>	<b>F8-6873</b>	<b>F8-7173</b>	<b>F8-7450</b>		
Ref.Nr.: 7700820501	Ref.Nr.: 77 00 805 733	Ref.Nr.: 7700818994	Ref.Nr.: 7664079	Ref.Nr.: 7700415728		

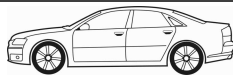
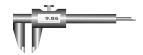
**Article Description****Article Nr.****Fitting Position**

<b>CLIO (B/C57_, 5/357_)</b>				<b>05/1990 → 09/1998</b>	
Spring Cap	All Models		<b>F8-7450</b>		
Control Arm-/Trailing Arm Bush	1.1, 1.2, 1.4, 1.7, 1.8, 1.8 Rsi, 1.9 D, 1.9 D, Williams		<b>G9-567</b>		H1=35; H2=46; d=12; D=40
Control Arm-/Trailing Arm Bush	1.1, 1.2, 1.4, 1.7, 1.8, 1.8 Rsi, 1.9 D, 1.9 D, Williams		<b>G9-568</b>		H1=35; H2=46; d=12; D1=40; D2=42
Bellow, steering	1.1, 1.2, 1.4, 1.7, 1.8, 1.8 16V, 1.8 Rsi, 1.9 D, 1.9 D	with clamps;	<b>LM-10001S</b>		d1=10; d2=30; L [mm]=158
Bellow, steering	1.1, 1.2, 1.4, 1.7, 1.8, 1.8 16V, 1.8 Rsi, 1.9 D, 1.9 D, Williams	with clamps;	<b>LM-10002S</b>		d1=10; d2=40; L [mm]=160
Bellow, steering	1.9 D	with clamps	<b>LM-10002S</b>		d1=10; d2=40; L [mm]=160
Bellow, steering	1.1, 1.2, 1.4, 1.7, 1.8, 1.8 16V, 1.8 Rsi, 1.9 D, 1.9 D	with clamps;	<b>LM-10042S</b>		d1=10; d2=27.5; L [mm]=155
Bellow Set, drive shaft	1.1, 1.2, 1.4, 1.7, 1.8, 1.8 16V, 1.8 Rsi, 1.9 D, 1.9 D, Williams		<b>M-860860</b>		H=80; d2=85; D1=25.8
Bellow Set, drive shaft	1.4		<b>MK-860860</b>		D1=25.8; D2113.5; L=88
<b>CLIO I Box (S57_)</b>				<b>01/1991 → 09/1998</b>	
Anti-Friction Bearing	All Models		<b>F8-3032</b>		H=9; d1=16; d2=27; D=56
Spring Cap	1.1, 1.2, 1.9 RND		<b>F8-5488</b>		
Spring Cap	1.9 D	F8Q 730	<b>F8-5488</b>		
Top Strut Mounting	1.9 D, 1.9 RND		<b>F8-5492</b>		
Belt Pulley, crankshaft	1.9 D, 1.9 RND		<b>F8-5645</b>		
Rubber Buffer, suspension	1.2		<b>F8-5863</b>		
Repair Kit, wheel suspension	1.1	Type: S571	<b>F8-6278</b>		
Repair Kit, wheel suspension	1.2	Type: S572, S577, S57A, S57R	<b>F8-6278</b>		
Repair Kit, wheel suspension	1.9 D	Type: 557_, S576, S57I, S57L	<b>F8-6278</b>		
Engine Mounting	1.1, 1.2, 1.9 D		<b>F8-6495</b>		
Spring Cap	All Models		<b>F8-7450</b>		
Control Arm-/Trailing Arm Bush	1.1, 1.2, 1.9 D		<b>G9-567</b>		H1=35; H2=46; d=12; D=40
Control Arm-/Trailing Arm Bush	1.1, 1.2, 1.9 D		<b>G9-568</b>		H1=35; H2=46; d=12; D1=40; D2=42
Bellow, steering	All Models	with clamps;	<b>LM-10001S</b>		d1=10; d2=30; L [mm]=158
Bellow, steering	All Models	with clamps;	<b>LM-10002S</b>		d1=10; d2=40; L [mm]=160
Bellow, steering	All Models	with clamps;	<b>LM-10042S</b>		d1=10; d2=27.5; L [mm]=155
Bellow Set, drive shaft	1.1, 1.2, 1.9 D		<b>M-860860</b>		H=80; d2=85; D1=25.8
<b>CLIO Mk II (BB0/1/2_, CB0/1/2_)</b>				<b>09/1998 → 02/2010</b>	
Dust Cover Kit, shock absorber	1.2, 1.2 16V, 1.4, 1.4 16V, 1.5 dCi, 1.6, 1.6 16V, 1.9 D, 1.9 dTi, 2.0 16V Sport		<b>AK-735257</b>		
Alternator Freewheel Clutch	1.9 dTi		<b>F5-1014</b>		

<b>AK-735257</b>	<b>F5-1014</b>	<b>F5-1029</b>	<b>F8-3032</b>	<b>F8-5488</b>	<b>F8-5492</b>	<b>F8-5645</b>
Ref.Nr.: 7700802667	Ref.Nr.: 8641982	Ref.Nr.: 7700110616	Ref.Nr.: 8200651172	Ref.Nr.: 7700828866	Ref.Nr.: 7700827436	Ref.Nr.: 7700724249
<b>F8-5863</b>	<b>F8-6278</b>	<b>F8-6495</b>	<b>F8-7450</b>	<b>G9-567</b>	<b>G9-568</b>	<b>LM-10001S</b>
Ref.Nr.: 7700428440	Ref.Nr.: 7701464320	Ref.Nr.: 77 00 805 733	Ref.Nr.: 7700415728	Ref.Nr.: 7700799065	Ref.Nr.: 7700799064	Ref.Nr.: 7700678649
<b>LM-10002S</b>	<b>LM-10042S</b>	<b>M-860860</b>	<b>MK-860860</b>			
Ref.Nr.: 7700706007	Ref.Nr.: 7701469497	Ref.Nr.: 7701462308	Ref.Nr.: 7701462100			

Article Description



Article Nr.

Fitting Position



CLIO Mk II (BB0/1/2_, CB0/1/2_)		09/1998 → 02/2010		
Alternator Freewheel Clutch	1.4 16V , 1.6 16V		F5-1029	
Alternator Freewheel Clutch	1.4 16V , 1.5 dCi, 1.6 Hi-Flex		F5-1061	
Alternator Freewheel Clutch	1.6 16V	K4M 742, K4M 743, K4M 748	F5-1061	
Alternator Freewheel Clutch	1.4 16V	K4J 710, K4J 711	F5-1062	
Alternator Freewheel Clutch	1.5 dCi		F5-1062	
Alternator Freewheel Clutch	1.6 16V	K4M 744, K4M 745, K4M 708	F5-1062	
Alternator Freewheel Clutch	1.5 dCi		F5-1083	
Alternator Freewheel Clutch	1.5 dCi		F5-1095	
Alternator Freewheel Clutch	1.5 dCi , 1.6 16V		F5-1122	
Anti-Friction Bearing	1.0, 1.2, 1.2 16V , 1.2 LPG, 1.4 , 1.4 16V , 1.5 dCi, 1.6 , 1.6 16V , 1.6 Hi-Flex , 1.9 D , 1.9 dTi , 2.0 16V Sport, 3.0 V6 Sport		F8-3032	H=9; d1=16; d2=27; D=56
Stabiliser Set	1.2 , 1.2 16V , 1.4 , 1.4 16V , 1.5 dCi, 1.6 , 1.6 16V , 1.9 D , 1.9 dTi , 2.0 16V Sport		F8-5087	
Control Arm-/Trailing Arm Bush	1.2, 1.4 , 1.4 16V , 1.6 , 1.6 16V , 1.9 D , 1.9 dTi , 2.0 16V Sport		F8-5253	⊕ ⊕ H=46; D1=45; D2=59
Mounting, automatic transmission	1.2 , 1.4 , 1.9 D		F8-5485	
Mounting, automatic transmission	1.6		F8-5485	
Mounting, automatic transmission	1.6 16V	03/1999 →	F8-5485	
Engine Mounting	1.4	03/1999 →; ; Type: BB0S	F8-5487	⊕
Engine Mounting	1.4 16V , 1.6 , 1.6 16V , 1.9 D		F8-5487	⊕
Spring Cap	1.2	D7F 726	F8-5488	⊕ ⊕
Spring Cap	1.2 16V	D4F714	F8-5488	⊕ ⊕
Spring Cap	1.2, 1.4 , 1.4 16V , 1.5 dCi, 1.6 , 1.9 D , 1.9 dTi , 2.0 16V Sport, 3.0 V6 Sport		F8-5488	⊕ ⊕
Spring Cap	1.4 16V	K4J 712	F8-5488	⊕ ⊕
Spring Cap	1.5 dCi	K9K 700	F8-5488	⊕ ⊕
Spring Cap	1.6 16V	K4M 748	F8-5488	⊕ ⊕
Spring Cap	1.9 D	F8Q 630	F8-5488	⊕ ⊕
Top Strut Mounting	1.0, 1.2 , 1.2 16V , 1.2 LPG, 1.4 , 1.4 16V , 1.5 dCi, 1.6 , 1.6 16V , 1.6 Hi-Flex , 1.9 D , 1.9 dTi , 2.0 16V Sport		F8-5496	⊕ ⊕
Belt Pulley, crankshaft	1.9 D		F8-5645	
Belt Pulley, crankshaft	1.9 dTi		F8-5656	
Belt Pulley, crankshaft	1.5 dCi		F8-5657	
Belt Pulley, crankshaft	1.5 dCi	04/2004 →	F8-5657	

<b>F5-1029</b>	<b>F5-1061</b>	<b>F5-1062</b>	<b>F5-1083</b>	<b>F5-1095</b>	<b>F5-1122</b>	<b>F8-3032</b>
Ref.Nr.: 7700110616	Ref.Nr.: 7700110616	Ref.Nr.: 7701476465	Ref.Nr.:	Ref.Nr.: 8200113636	Ref.Nr.:	Ref.Nr.: 8200651172
<b>F8-5087</b>	<b>F8-5253</b>	<b>F8-5485</b>	<b>F8-5487</b>	<b>F8-5488</b>	<b>F8-5496</b>	<b>F8-5645</b>
Ref.Nr.: 54616-00QAA	Ref.Nr.: 77 00 419 236	Ref.Nr.: 7700788318	Ref.Nr.: 7700434370	Ref.Nr.: 7700828866	Ref.Nr.: 7700829529	Ref.Nr.: 7700724249
<b>F8-5656</b>	<b>F8-5657</b>	<b>F8-5863</b>				
Ref.Nr.: 7700115309	Ref.Nr.: 8200185800	Ref.Nr.: 7700428440				



**Article Description****Article Nr.****Fitting Position**

<b>CLIO Mk II (BB0/1/2, CB0/1/2)</b>			<b>09/1998 → 02/2010</b>	
Rubber Buffer, suspension	1.0, 1.2, 1.2 16V, 1.4, 1.4 16V, 1.5 dCi, 1.6, 1.6 16V, 1.6 Flex, 1.6 Hi-Flex, 1.9 D, 1.9 dTi		<b>F8-5863</b>	
Mounting, axle beam	1.0, 1.2, 1.2 16V, 1.4, 1.4 16V, 1.5 dCi, 1.6, 1.6 16V, 1.9 D, 1.9 dTi, 2.0 16V Sport, 3.0 V6 Sport		<b>F8-6174</b>	
Gear, camshaft	1.9 dTi	Engine Management: Timing Belt; 40	<b>F8-6254</b>	
Top Strut Mounting	1.0, 1.2, 1.2 16V, 1.2 LPG, 1.4, 1.4 16V, 1.5 dCi, 1.6, 1.6 16V, 1.6 Hi-Flex, 1.9 D, 1.9 dTi, 2.0 16V Sport		<b>F8-6329</b>	
Engine Mounting	1.9 D		<b>F8-6481</b>	
Engine Mounting	1.2, 1.2 16V, 1.4 16V, 1.5 dCi, 1.6 16V		<b>F8-6598</b>	
Engine Mounting	1.9 dTi	11/1999 →	<b>F8-6598</b>	
Belt Pulley, crankshaft	1.4 16V	Number of Ribs: 6;	<b>F8-7094</b>	
Belt Pulley, crankshaft	1.4 16V, 1.6 16V	Number of Ribs: 6	<b>F8-7094</b>	
Anti-Friction Bearing	1.5 dCi		<b>F8-7152</b>	
Bearing, drive shaft	1.2, 1.4, 1.6, 1.9 D		<b>F8-7173</b>	
Spring Cap	All Models		<b>F8-7450</b>	
Stabiliser Mounting	2.0 16V Sport		<b>F8-7942</b>	
Repair Kit, suspension strut	1.0, 1.2, 1.2 16V, 1.2 LPG, 1.4 16V, 1.5 dCi, 1.6, 1.6 16V, 1.6 Hi-Flex, 1.9 D, 1.9 dTi, 2.0 16V Sport	with mounting parts	<b>F8-8088</b>	
Repair Kit, suspension strut	1.2	D4F714;  with mounting parts	<b>F8-8088</b>	
Repair Kit, suspension strut	1.4	E7J 780;  with mounting parts	<b>F8-8088</b>	
Repair Kit, suspension strut	1.4 16V	K4J 712, K4J711, K4J713;  with mounting parts	<b>F8-8088</b>	
Repair Kit, suspension strut	1.5 dCi	K9K714;  with mounting parts	<b>F8-8088</b>	
Repair Kit, suspension strut	2.0 16V Sport	F4R730;  with mounting parts	<b>F8-8088</b>	
Engine Mounting	1.4 16V, 1.5 dCi		<b>F8-8138</b>	
Engine Mounting	1.5 dCi		<b>F8-8151</b>	
Engine Mounting	1.5 dCi		<b>F8-8172</b>	
Engine Mounting	1.0, 1.2, 1.2 16V, 1.2 LPG		<b>F8-8188</b>	
Bellow, steering	1.2, 1.2 16V, 1.4, 1.4 16V, 1.5 dCi, 1.6, 1.6 16V, 1.9 D, 1.9 dTi, 2.0 16V Sport, 3.0 V6 Sport	for steering gear ID: SMI; with clamps;	<b>LM-10000S</b>	
Bellow, steering	1.2, 1.5 dCi, 1.9 D	with clamps	<b>LM-10000S</b>	
Bellow, steering	1.2, 1.2 16V, 1.4, 1.4 16V, 1.5 dCi, 1.6, 1.6 16V, 1.9 D, 1.9 dTi, 2.0 16V Sport, 3.0 V6 Sport	with clamps	<b>LM-10009S</b>	
Bellow, steering	1.2, 1.2 16V, 1.4, 1.4 16V, 1.5 dCi, 1.6, 1.6 16V, 1.9 D, 1.9 dTi, 2.0 16V Sport, 3.0 V6 Sport	; Manufacturer Restriction: TRW; with clamps;	<b>LM-10009S</b>	
Bellow, steering	1.2, 1.2 16V, 1.4, 1.4 16V, 1.5 dCi, 1.6, 1.9 D, 1.9 dTi	Manufacturer Restriction: TRW; with clamps	<b>LM-10057S</b>	

<b>F8-5863</b>	<b>F8-6174</b>	<b>F8-6254</b>	<b>F8-6329</b>	<b>F8-6481</b>	<b>F8-6598</b>	<b>F8-7094</b>
Ref.Nr.: 7700428440	Ref.Nr.: 7700429441	Ref.Nr.: 8200125710	Ref.Nr.: 7700829529	Ref.Nr.: 77 00 428 936	Ref.Nr.: 77 00 437 854	Ref.Nr.: 8200392683
<b>F8-7152</b>	<b>F8-7173</b>	<b>F8-7450</b>	<b>F8-7942</b>	<b>F8-8088</b>	<b>F8-8138</b>	<b>F8-8151</b>
Ref.Nr.: 54325-AX000	Ref.Nr.: 7664079	Ref.Nr.: 7700415728	Ref.Nr.: 7700784171	Ref.Nr.: 7700798900	Ref.Nr.: 8200155207	Ref.Nr.: 8200151995
<b>F8-8172</b>	<b>F8-8188</b>	<b>LM-10000S</b>	<b>LM-10009S</b>	<b>LM-10057S</b>	<b>M-860860</b>	
Ref.Nr.: 8200170362	Ref.Nr.: 11270-00QAA	Ref.Nr.: 6000025546	Ref.Nr.: 7701469486	Ref.Nr.: 7701471141	Ref.Nr.: 7701462308	

Article Description



Article Nr.

Fitting Position



CLIO Mk II (BB0/1/2_, CB0/1/2_)			09/1998 → 02/2010	
Bellow Set, drive shaft	1.2, 1.2 16V, 1.4, 1.4 16V, 1.5 dCi, 1.6, 1.6 16V, 1.9 D, 1.9 dTi, 2.0 16V Sport		M-860860	H=80; d2=85; D1=25.8
CLIO II Box (SB0/1/2_)			09/1998 → 10/2004	
Dust Cover Kit, shock absorber	1.5 dCi		AK-735257	
Alternator Freewheel Clutch	1.9 DTi		F5-1014	
Alternator Freewheel Clutch	1.5 dCi		F5-1061	
Alternator Freewheel Clutch	1.5 dCi		F5-1083	
Alternator Freewheel Clutch	1.5 dCi	Alternator Charge Current [A]: 120; for OE: 8200360480; Manufacturer Restriction: Bosch	F5-1095	
Anti-Friction Bearing	1.1, 1.2, 1.5 dCi, 1.9 D, 1.9 DTi		F8-3032	H=9; d1=16; d2=27; D=56
Engine Mounting	1.9 D		F8-5487	
Spring Cap	All Models		F8-5488	
Top Strut Mounting	All Models		F8-5496	
Belt Pulley, crankshaft	1.9 D		F8-5645	
Belt Pulley, crankshaft	1.9 DTi		F8-5656	
Belt Pulley, crankshaft	1.5 dCi		F8-5657	
Belt Pulley, crankshaft	1.5 dCi	04/2004 →	F8-5657	
Belt Pulley, crankshaft	1.5 dCi	08/2004 →;  K9K 702, K9K 710, K9K 716	F8-5657	
Rubber Buffer, suspension	All Models		F8-5863	
Mounting, axle beam	All Models		F8-6174	H1=72; H2=50.5; d=10; D=45.5
Gear, camshaft	1.9 DTi	Engine Management: Timing Belt;  40	F8-6254	d=13; D=120; W=30
Top Strut Mounting	1.1, 1.2, 1.5 dCi, 1.9 D, 1.9 DTi		F8-6329	
Engine Mounting	1.9 D		F8-6481	
Spring Cap	1.1, 1.2, 1.5 dCi, 1.9 D, 1.9 DTi		F8-7450	
Repair Kit, suspension strut	1.1	D7F 720;  with mounting parts	F8-8088	
Repair Kit, suspension strut	1.2	D7F 726, D7F 746;  with mounting parts	F8-8088	
Repair Kit, suspension strut	1.5 dCi, 1.9 D, 1.9 DTi	with mounting parts	F8-8088	
Engine Mounting	1.5 dCi		F8-8151	
Engine Mounting	1.5 dCi		F8-8172	
Bellow, steering	1.1, 1.5 dCi, 1.9 D	; Manufacturer Restriction: TRW; with clamps;	LM-10009S	d1=12; d2=40; L [mm]=170
Bellow, steering	1.1, 1.5 dCi, 1.9 D	; with clamps	LM-10009S	d1=12; d2=40; L [mm]=170
Bellow, steering	1.1, 1.5 dCi, 1.9 D	Manufacturer Restriction: TRW; with clamps	LM-10057S	d1=11; d2=42; L [mm]=143
Bellow Set, drive shaft	1.1, 1.5 dCi, 1.9 D		M-860860	H=80; d2=85; D1=25.8

AK-735257	F5-1014	F5-1061	F5-1083	F5-1095	F8-3032	F8-5487
Ref.Nr.: 7700802667	Ref.Nr.: 8641982	Ref.Nr.: 7700110616	Ref.Nr.:	Ref.Nr.: 8200113636	Ref.Nr.: 8200651172	Ref.Nr.: 7700434370
F8-5488	F8-5496	F8-5645	F8-5656	F8-5657	F8-5863	F8-6174
Ref.Nr.: 7700828866	Ref.Nr.: 7700829529	Ref.Nr.: 7700724249	Ref.Nr.: 7700115309	Ref.Nr.: 8200185800	Ref.Nr.: 7700428440	Ref.Nr.: 7700429441
F8-6254	F8-6329	F8-6481	F8-7450	F8-8088	F8-8151	F8-8172
Ref.Nr.: 8200125710	Ref.Nr.: 7700829529	Ref.Nr.: 77 00 428 936	Ref.Nr.: 7700415728	Ref.Nr.: 7700798900	Ref.Nr.: 8200151995	Ref.Nr.: 8200170362

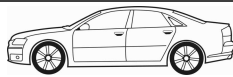
**Article Description****Article Nr.****Fitting Position**

<b>CLIO III (BR0/1, CR0/1)</b>			<b>05/2005 → 02/2010</b>	
Dust Cover Kit, shock absorber	1.2 16V, 1.4 16V, 1.5 dCi, 1.6 16V, 2.0 16V, 2.0 16V Sport		<b>AK-735258</b>	
Dust Cover Kit, shock absorber	1.2 16V, 1.4 16V, 1.5 dCi, 1.6 16V, 2.0 16V, 2.0 16V Sport		<b>AK-735259</b>	
Alternator Freewheel Clutch	1.4 16V, 1.6 Hi-Flex		<b>F5-1061</b>	
Alternator Freewheel Clutch	1.5 dCi	K9K 714	<b>F5-1083</b>	
Alternator Freewheel Clutch	1.5 dCi		<b>F5-1095</b>	
Alternator Freewheel Clutch	2.0 16V		<b>F5-1112</b>	
Alternator Freewheel Clutch	1.4 16V, 1.5 dCi, 1.6 16V		<b>F5-1122</b>	
Belt Pulley, crankshaft	1.4 16V	11/2007 →;	<b>F8-5657</b>	
Belt Pulley, crankshaft	1.5 dCi		<b>F8-5657</b>	
Belt Pulley, crankshaft	1.5 dCi	11/2007 →	<b>F8-5657</b>	
Belt Pulley, crankshaft	1.5 dCi	11/2007 →;  K9K 768	<b>F8-5657</b>	
Belt Pulley, crankshaft	1.6 16V	11/2007 →;  K4M 801;	<b>F8-5657</b>	
Top Strut Mounting	1.2 16V, 1.2 16V Hi-Flex, 1.4 16V, 1.5 dCi, 1.6 16V, 1.6 16V GT, 2.0 16V, 2.0 16V Sport		<b>F8-6338</b>	
Control Arm-/Trailing Arm Bush	1.2, 1.2 16V, 1.2 16V Hi-Flex, 1.4 16V, 1.5 dCi, 1.6 16V, 1.6 16V GT, 2.0 16V, 2.0 16V Sport		<b>F8-6523</b>	d=12; D=40; Thick. [mm]=55
Top Strut Mounting	1.2 16V, 1.2 16V Hi-Flex, 1.4 16V, 1.5 dCi, 1.6 16V, 2.0 16V, 2.0 16V Sport		<b>F8-6525</b>	
Top Strut Mounting	1.2 16V, 1.2 16V Hi-Flex, 1.4 16V, 1.5 dCi, 1.6 16V, 2.0 16V, 2.0 16V Sport		<b>F8-6526</b>	
Control Arm-/Trailing Arm Bush	1.2 16V, 1.2 16V Hi-Flex, 1.4 16V, 1.5 dCi, 1.6 16V, 2.0 16V, 2.0 16V Sport		<b>F8-6662</b>	H=53; d=12; D=58
Engine Mounting	1.2, 1.2 16V, 1.2 16V Hi-Flex, 1.4 16V, 1.5 dCi, 1.6 16V, 2.0 16V, 2.0 16V Sport		<b>F8-6664</b>	
Engine Mounting	1.2, 1.2 16V, 1.2 16V Hi-Flex, 1.4 16V, 1.5 dCi, 1.6 16V, 2.0 16V, 2.0 16V Sport		<b>F8-6665</b>	
Engine Mounting	1.2 16V, 1.2 16V Hi-Flex		<b>F8-6680</b>	L=185
Top Strut Mounting	1.2 16V, 1.4 16V, 1.5 dCi, 1.6 16V, 2.0 16V Sport		<b>F8-7057</b>	
Anti-Friction Bearing	1.2, 1.2 16V, 1.2 16V Hi-Flex, 1.4 16V, 1.5 dCi, 1.6 16V, 1.6 16V GT, 2.0 16V, 2.0 16V Sport		<b>F8-7152</b>	
Belt Pulley, crankshaft	1.5 dCi	Number of Ribs: 5; Parameter: 6PK	<b>F8-7732</b>	
Engine Mounting	2.0 16V Sport		<b>F8-8162</b>	
<b>CLIO Grandtour (KR0/1 )</b>			<b>02/2008 →</b>	
Alternator Freewheel Clutch	1.4 16V		<b>F5-1061</b>	
Alternator Freewheel Clutch	1.5 dCi	K9K 714	<b>F5-1083</b>	
Alternator Freewheel Clutch	1.5 dCi		<b>F5-1095</b>	
Alternator Freewheel Clutch	1.5 dCi	K9K 768	<b>F5-1095</b>	

<b>AK-735258</b>	<b>AK-735259</b>	<b>F5-1061</b>	<b>F5-1083</b>	<b>F5-1095</b>	<b>F5-1112</b>	<b>F5-1122</b>
Ref.Nr.: 8200127285	Ref.Nr.: 8200389766	Ref.Nr.: 7700110616	Ref.Nr.:	Ref.Nr.: 8200113636	Ref.Nr.:	Ref.Nr.:
<b>F8-5657</b>	<b>F8-6338</b>	<b>F8-6523</b>	<b>F8-6525</b>	<b>F8-6526</b>	<b>F8-6662</b>	<b>F8-6664</b>
Ref.Nr.: 8200185800	Ref.Nr.: 54325-AX000	Ref.Nr.: 54500-BC42A	Ref.Nr.: 54320-AX600	Ref.Nr.: 8200504291	Ref.Nr.: 82 00 346 942	Ref.Nr.: 8200127324
<b>F8-6665</b>	<b>F8-6680</b>	<b>F8-7057</b>	<b>F8-7152</b>	<b>F8-7732</b>	<b>F8-8162</b>	
Ref.Nr.: 8200127321	Ref.Nr.: 8200042453	Ref.Nr.: 54320AX600	Ref.Nr.: 54325-AX000	Ref.Nr.: 8200477938	Ref.Nr.: 8200042454	

Article Description



Article Nr.

Fitting Position



<b>CLIO Grandtour (KR0/1_)</b>		<b>02/2008 →</b>	
Alternator Freewheel Clutch	1.4 16V, 1.5 dCi, 1.6 16V	<b>F5-1122</b>	
Belt Pulley, crankshaft	1.5 dCi	<b>F8-5657</b>	
Control Arm-/Trailing Arm Bush	1.2 16V, 1.2 16V Hi-Flex, 1.4 16V, 1.5 dCi, 1.6 16V	<b>F8-6523</b>	d=12; D=40; Thick. [mm]=55
Control Arm-/Trailing Arm Bush	1.2 16V, 1.2 16V Hi-Flex, 1.5 dCi, 1.6 16V	<b>F8-6662</b>	H=53; d=12; D=58
Anti-Friction Bearing	1.2 16V, 1.2 16V Hi-Flex, 1.5 dCi, 1.6 16V	<b>F8-7152</b>	
<b>CLIO IV</b>		<b>11/2012 →</b>	
Alternator Freewheel Clutch	0.9 TCe 90, 1.5 dCi 90	<b>F5-1061</b>	
Alternator Freewheel Clutch	1.5 dCi 75	<b>F5-1122</b>	
Control Arm-/Trailing Arm Bush	0.9 TCe 90, 1.2 16V, 1.2 TCe 120, 1.5 dCi 75, 1.5 dCi 90	<b>F8-7989</b>	d=12; D=24, 58; Thick. [mm]=53
<b>CLIO Grandtour IV</b>		<b>01/2013 →</b>	
Alternator Freewheel Clutch	0.9 TCe 90, 1.5 dCi 75	<b>F5-1061</b>	
Alternator Freewheel Clutch	1.5 dCi 75	<b>F5-1122</b>	
<b>DUSTER</b>		<b>06/2011 →</b>	
Alternator Freewheel Clutch	1.6 16V	<b>F5-1061</b>	
Alternator Freewheel Clutch	1.5 dCi, 1.6 16V	<b>F5-1122</b>	
Top Strut Mounting	1.6 16V, 2.0	<b>F8-6596</b>	
Rubber Buffer, suspension	1.5 dCi, 1.6 16V, 2.0	<b>F8-7900</b>	
Control Arm-/Trailing Arm Bush	2.0 4x4	<b>F8-8070</b>	D=30, 35; Thick. [mm]=40
<b>ESPACE (J11_)</b>		<b>07/1984 → 12/1992</b>	
Control Arm-/Trailing Arm Bush	2.0, 2.0 i, 2.1 TD, 2.2	<b>F8-5068</b>	H=83; d=16; D=40
Control Arm-/Trailing Arm Bush	2.0, 2.0 i, 2.1 TD, 2.2	<b>F8-5074</b>	
Control Arm-/Trailing Arm Bush	2.0, 2.0 i, 2.1 TD, 2.2	<b>F8-5111</b>	H=32; d=14; D=48
Control Arm-/Trailing Arm Bush	2.0 i Quadra	<b>F8-5111</b>	H=32; d=14; D=48
Mounting, axle beam	2.0, 2.0 i, 2.1 TD, 2.2	<b>F8-5802</b>	
Suspension, panhard rod	2.0, 2.0 i, 2.1 TD, 2.2	<b>F8-5803</b>	H=41; d=10; D=34
Engine Mounting	2.0, 2.0 i, 2.1 TD, 2.2	<b>F8-6867</b>	H=49; D=60; M8
Engine Mounting	2.0, 2.0 i, 2.1 TD, 2.2	<b>F8-6868</b>	
Engine Mounting	2.0, 2.0 i, 2.1 TD, 2.2	<b>F8-6869</b>	
Engine Mounting	2.0, 2.0 i, 2.1 TD, 2.2	<b>F8-6870</b>	
Engine Mounting	2.0 i Quadra, 2.2 Quadra	<b>F8-6876</b>	

<b>F5-1061</b>	<b>F5-1122</b>	<b>F8-5068</b>	<b>F8-5074</b>	<b>F8-5111</b>	<b>F8-5657</b>	<b>F8-5802</b>
Ref.Nr.: 7700110616	Ref.Nr.:	Ref.Nr.: 7700765840	Ref.Nr.: 7704002466	Ref.Nr.: 7700781463	Ref.Nr.: 8200185800	Ref.Nr.: 6025000245
<b>F8-5803</b>	<b>F8-6523</b>	<b>F8-6596</b>	<b>F8-6662</b>	<b>F8-6867</b>	<b>F8-6868</b>	<b>F8-6869</b>
Ref.Nr.: 6025000249	Ref.Nr.: 54500-BC42A	Ref.Nr.: 6001547499	Ref.Nr.: 82 00 346 942	Ref.Nr.: 7704000767	Ref.Nr.: 7704000769	Ref.Nr.: 7704000777
<b>F8-6870</b>	<b>F8-6876</b>	<b>F8-7152</b>	<b>F8-7900</b>	<b>F8-7989</b>	<b>F8-7993</b>	<b>F8-8070</b>
Ref.Nr.: 7704000829	Ref.Nr.: 7700768010	Ref.Nr.: 54325-AX000	Ref.Nr.: 6001548402	Ref.Nr.: 8200041166	Ref.Nr.: 6025311529	Ref.Nr.: 82 00 839 121

**Article Description****Article Nr.****Fitting Position**

<b>ESPACE (J11_)</b>				<b>07/1984 → 12/1992</b>	
Control Arm-/Trailing Arm Bush	All Models		<b>F8-7993</b>		
Bellow, steering	All Models	with clamps;	<b>LM-10002S</b>		d1=10; d2=40; L [mm]=160
<b>ESPACE Mk II (J/S63_)</b>				<b>01/1991 → 12/1996</b>	
Control Arm-/Trailing Arm Bush	2.0, 2.1 TD, 2.2, 2.8 V6		<b>F8-5111</b>		H=32; d=14; D=48
Control Arm-/Trailing Arm Bush	2.1 TD, 2.2 4x4		<b>F8-5111</b>		H=32; d=14; D=48
Mounting, axle beam	2.0, 2.1 TD, 2.2, 2.8 V6		<b>F8-5802</b>		
Suspension, panhard rod	2.0, 2.1 TD, 2.2, 2.8 V6		<b>F8-5803</b>		H=41; d=10; D=34
Control Arm-/Trailing Arm Bush	2.0, 2.1 RTDT Quadra, 2.1 TD, 2.2, 2.8 V6		<b>F8-6116</b>		d=22.5; L=63; D=55
Control Arm-/Trailing Arm Bush	2.2 4x4	J7T 772	<b>F8-6116</b>		d=22.5; L=63; D=55
Stabiliser Mounting	2.0, 2.1 RTDT Quadra, 2.1 TD, 2.2, 2.2 4x4		<b>F8-6221</b>		d=22
Engine Mounting	2.0, 2.1 RTDT Quadra, 2.1 TD		<b>F8-6489</b>		
Engine Mounting	2.2	J7T 772	<b>F8-6489</b>		
Engine Mounting	2.2 4x4	Type: J637	<b>F8-6489</b>		
Engine Mounting	2.8 V6	Z7W 712	<b>F8-6489</b>		
Engine Mounting	2.0, 2.1 RTDT Quadra, 2.1 TD		<b>F8-6504</b>		
Engine Mounting	2.2	J7T 772	<b>F8-6504</b>		
Engine Mounting	2.2 4x4	Type: J637	<b>F8-6504</b>		
Engine Mounting	2.8 V6	Z7W 712	<b>F8-6504</b>		
Engine Mounting	2.8 V6	Type: J638	<b>F8-6875</b>		
Engine Mounting	2.0, 2.1 TD, 2.2, 2.8 V6		<b>F8-6876</b>		
Engine Mounting	2.2 4x4	; Type: J637	<b>F8-6876</b>		
Belt Pulley, crankshaft	2.1 TD	Number of Ribs: 2	<b>F8-7091</b>		Belt Pulley Ø [mm]=142; Mounting points diam.[mm]=15; W=38
Control Arm-/Trailing Arm Bush	All Models		<b>F8-7993</b>		
Bellow, steering	All Models	with clamps;	<b>LM-10002S</b>		d1=10; d2=40; L [mm]=160
<b>ESPACE Mk III (JE0_)</b>				<b>11/1996 → 10/2002</b>	
Dust Cover Kit, shock absorber	1.9 dTi, 2.0, 2.0 16V, 2.2 12V TD, 2.2 dCi, 3.0, 3.0 V6 24V		<b>AK-735042</b>		
Alternator Freewheel Clutch	1.9 dTi		<b>F5-1014</b>		
Anti-Friction Bearing	1.9 dTi, 2.0, 2.0 16V, 2.2 12V TD, 2.2 dCi, 3.0, 3.0 V6 24V		<b>F8-3012</b>		H=20; d=66; D=100
Anti-Friction Bearing	1.9 dTi, 2.0, 2.0 16V, 2.2 12V TD, 3.0, 3.0 V6 24V		<b>F8-3033</b>		H=20; d1=62; d2=64; D=100

<b>AK-735042</b>	<b>F5-1014</b>	<b>F8-3012</b>	<b>F8-3033</b>	<b>F8-5111</b>	<b>F8-5478</b>	<b>F8-5802</b>
Ref.Nr.: 7700776743	Ref.Nr.: 8641982	Ref.Nr.: 503527	Ref.Nr.: 7700797666	Ref.Nr.: 7700781463	Ref.Nr.: 7700818372	Ref.Nr.: 6025000245
<b>F8-5803</b>	<b>F8-6116</b>	<b>F8-6221</b>	<b>F8-6489</b>	<b>F8-6504</b>	<b>F8-6875</b>	<b>F8-6876</b>
Ref.Nr.: 6025000249	Ref.Nr.: 7700781441	Ref.Nr.: 7700797821	Ref.Nr.: 77 00 783 018	Ref.Nr.: 77 00 759 732	Ref.Nr.: 6025102333	Ref.Nr.: 7700768010
<b>F8-7091</b>	<b>F8-7993</b>	<b>LM-10002S</b>				
Ref.Nr.: 7700853470	Ref.Nr.: 6025311529	Ref.Nr.: 7700706007				

Article Description



Article Nr.

Fitting Position



<b>ESPACE Mk III (JE0_)</b>		<b>11/1996 → 10/2002</b>	
Mounting, automatic transmission	2.0, 2.0 16V	F8-5478	
Belt Pulley, crankshaft	2.2 12V TD, 2.2 D, 2.2 dCi	F8-5648	
Belt Pulley, crankshaft	1.9 dTi	F8-5656	
Gear, camshaft	1.9 dTi	F8-6254	d=13; D=120; W=30
Top Strut Mounting	1.9 dTi, 2.0, 2.0 16V, 2.2 12V TD, 2.2 dCi, 3.0, 3.0 V6 24V	F8-6333	
Engine Mounting	2.2 12V TD	F8-6906	L=130
Engine Mounting	3.0 V6 24V	F8-6906	L=130
Engine Mounting	1.9 dTi, 2.0, 2.0 16V	F8-6907	d1=10; d2=10; L=170
Belt Pulley, crankshaft	2.2 dCi	F8-7092	Belt Pulley Ø [mm]=152; Mounting points diam.[mm]=30.6; W=45.5
Belt Pulley, crankshaft	1.9 dTi	F8-7093S1	
Top Strut Mounting	1.9 dTi, 2.0, 2.0 16V, 2.2 12V TD, 2.2 dCi, 3.0, 3.0 V6 24V	F8-7157	
Belt Pulley, crankshaft	2.0	F8-7654	
Control Arm-/Trailing Arm Bush	All Models	F8-7993	
Control Arm-/Trailing Arm Bush	1.9 dTi, 2.0, 2.0 16V, 2.2 12V TD, 2.2 dCi, 3.0, 3.0 V6 24V	G9-674	H1=30; H2=55; d=18; D1=30; D2=55
Bellow, steering	All Models	LM-10002S	
Bellow, steering	All Models	LM-10032S	

<b>ESPACE Mk IV (JK0/1_)</b>		<b>11/2002 → 02/2005</b>	
Dust Cover Kit, shock absorber	1.9 dCi, 2.0, 2.0 dCi, 2.0 Turbo, 2.2 dCi, 3.0 dCi, 3.5 V6	AK-735062	
Alternator Freewheel Clutch	3.0 dCi	F5-1096	
Alternator Freewheel Clutch	2.0 dCi	F5-1110	
Alternator Freewheel Clutch	2.0 dCi	F5-1129	
Engine Mounting	1.9 dCi	F8-6666	
Engine Mounting	2.2 dCi, 3.0 dCi, 3.5 V6	F8-6667	
Engine Mounting	1.9 dCi, 2.0, 2.0 Turbo	F8-6668	
Engine Mounting	1.9 dCi, 2.0, 2.0 dCi, 2.0 Turbo, 2.2 dCi, 3.0 dCi, 3.5 V6	F8-6671	
Engine Mounting	1.9 dCi, 2.0, 2.0 dCi, 2.0 Turbo, 2.2 dCi, 3.0 dCi, 3.5 V6	F8-6672	
Belt Pulley, crankshaft	1.9 dCi	F8-7093S1	
Supporting Ring, suspension strut bearing	1.9 dCi, 2.0, 2.0 dCi, 2.0 Turbo, 2.2 dCi, 3.0 dCi, 3.5 V6	F8-7469	

<b>AK-735062</b>	<b>F5-1096</b>	<b>F5-1110</b>	<b>F5-1129</b>	<b>F8-5478</b>	<b>F8-5648</b>	<b>F8-5656</b>
Ref.Nr.: 8200180137	Ref.Nr.: 7701066401	Ref.Nr.: 8200489514	Ref.Nr.: 23151-JG71B	Ref.Nr.: 7700818372	Ref.Nr.: 7700104292	Ref.Nr.: 7700115309
<b>F8-6254</b>	<b>F8-6333</b>	<b>F8-6666</b>	<b>F8-6667</b>	<b>F8-6668</b>	<b>F8-6671</b>	<b>F8-6672</b>
Ref.Nr.: 8200125710	Ref.Nr.: 6025305979	Ref.Nr.: 8200302003	Ref.Nr.: 8200250743	Ref.Nr.: 8200181589	Ref.Nr.: 8200000514	Ref.Nr.: 8200000515
<b>F8-6906</b>	<b>F8-6907</b>	<b>F8-7092</b>	<b>F8-7093S1</b>	<b>F8-7157</b>	<b>F8-7469</b>	<b>F8-7633</b>
Ref.Nr.: 7700411189	Ref.Nr.: 6025304389	Ref.Nr.: 8200207436	Ref.Nr.: 12303AW300	Ref.Nr.: 6025305980	Ref.Nr.: 7700424482	Ref.Nr.: 7700424481

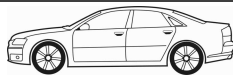
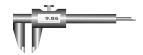
**Article Description****Article Nr.****Fitting Position**

<b>ESPACE Mk IV (JK0/1_)</b>			<b>11/2002 → 02/2005</b>		
Anti-Friction Bearing	1.9 dCi , 2.0 , 2.0 dCi , 2.0 Turbo , 2.2 dCi , 3.0 dCi , 3.5 V6		<b>F8-7633</b>		
Belt Pulley, crankshaft	2.0 , 2.0 Turbo		<b>F8-7656</b>		
Belt Pulley, crankshaft	2.0 dCi	Number of Ribs: 6; Parameter: 7PK	<b>F8-7657</b>		
Control Arm-/Trailing Arm Bush	1.9 dCi , 2.0 , 2.0 dCi , 2.2 dCi , 3.0 dCi , 3.5 V6		<b>F8-7988</b>		
Control Arm-/Trailing Arm Bush	2.0 Turbo	F4R 794, F4R 795, F4R 796	<b>F8-7988</b>		
Control Arm-/Trailing Arm Bush	1.9 dCi , 2.0 , 2.0 dCi , 2.0 Turbo , 2.2 dCi , 3.0 dCi , 3.5 V6		<b>F8-7990</b>		
<b>FLUENCE (L30_)</b>			<b>02/2010 →</b>		
Alternator Freewheel Clutch	2.0 16V		<b>F5-1025</b>		
Alternator Freewheel Clutch	1.5 dCi		<b>F5-1061</b>		
Alternator Freewheel Clutch	1.6 16V		<b>F5-1122</b>		
<b>FUEGO (136_)</b>			<b>02/1980 → 10/1985</b>		
Control Arm-/Trailing Arm Bush	1.4 TL/GTL, 1.6 TS/GTS , 1.6 Turbo , 2.0 TX/GTX , 2.1 TD		<b>G9-600</b>		
Bellow Set, drive shaft	1.4 TL/GTL, 2.1 TD		<b>MK-850850</b>		
Bellow Set, drive shaft	1.6 TS/GTS		<b>MK-850850</b>		
<b>GRAND SCÉNIC II (JM0/1_)</b>			<b>04/2004 → 11/2008</b>		
Dust Cover Kit, shock absorber	1.5 dCi , 1.6, 1.9 dCi , 2.0		<b>AK-735260</b>		
Alternator Freewheel Clutch	1.5 dCi , 1.6		<b>F5-1061</b>		
Alternator Freewheel Clutch	1.6		<b>F5-1062</b>		
Alternator Freewheel Clutch	2.0 dCi		<b>F5-1063</b>		
Alternator Freewheel Clutch	1.5 dCi , 1.6		<b>F5-1122</b>		
Belt Pulley, crankshaft	1.5 dCi		<b>F8-5657</b>		
Top Strut Mounting	1.5 dCi , 1.6, 1.9 dCi , 2.0, 2.0 dCi		<b>F8-6175</b>		
Top Strut Mounting	1.5 dCi , 1.6, 1.9 dCi , 2.0, 2.0 dCi		<b>F8-6195</b>		
Anti-Friction Bearing	1.5 dCi , 1.6, 1.9 dCi , 2.0, 2.0 dCi		<b>F8-6335</b>		
Engine Mounting	1.9 dCi , 2.0		<b>F8-6420</b>		
Engine Mounting	1.5 dCi		<b>F8-6522</b>		L=265
Engine Mounting	2.0 dCi		<b>F8-6678</b>		
Mounting, axle beam	1.5 dCi , 1.6, 1.9 dCi , 2.0, 2.0 dCi		<b>F8-6679</b>		
Engine Mounting	1.9 dCi , 2.0		<b>F8-6680</b>		
Holder, engine mounting	1.5 dCi , 1.6, 1.9 dCi , 2.0, 2.0 dCi		<b>F8-6681</b>		
Holder, engine mounting	1.5 dCi , 1.6, 1.9 dCi , 2.0, 2.0 dCi		<b>F8-6682</b>		

<b>AK-735260</b>	<b>F5-1025</b>	<b>F5-1061</b>	<b>F5-1062</b>	<b>F5-1063</b>	<b>F5-1122</b>	<b>F8-5657</b>
Ref.Nr.: 8200411123	Ref.Nr.: 23151-00Q0B	Ref.Nr.: 7700110616	Ref.Nr.: 7701476465	Ref.Nr.:	Ref.Nr.:	Ref.Nr.: 8200185800
<b>F8-6175</b>	<b>F8-6195</b>	<b>F8-6335</b>	<b>F8-6420</b>	<b>F8-6522</b>	<b>F8-6678</b>	<b>F8-6679</b>
Ref.Nr.: 8200222463	Ref.Nr.: 7701207678	Ref.Nr.: 7701208891	Ref.Nr.: 8200338381	Ref.Nr.: 8200338385	Ref.Nr.: 8200355673	Ref.Nr.: 8200038243
<b>F8-6680</b>	<b>F8-6681</b>	<b>F8-6682</b>	<b>F8-7093</b>	<b>F8-7633</b>	<b>F8-7656</b>	<b>F8-7657</b>
Ref.Nr.: 8200042453	Ref.Nr.: 8200197453	Ref.Nr.: 8200197452	Ref.Nr.: 8200457775	Ref.Nr.: 7700424481	Ref.Nr.: 8200619927	Ref.Nr.: 1230300Q0A

Article Description

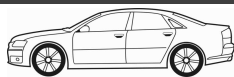

Article Nr.

Fitting Position



<b>GRAND SCÉNIC II (JM0/1_)</b>		<b>04/2004 → 11/2008</b>	
Belt Pulley, crankshaft	1.9 dCi	Number of Ribs: 7	<b>F8-7093</b>
Belt Pulley, crankshaft	2.0 dCi	Number of Ribs: 6; Parameter: 7PK	<b>F8-7657</b>
Engine Mounting	1.5 dCi		<b>F8-7746</b> ⊕
Control Arm-/Trailing Arm Bush	1.5 dCi , 1.6, 1.9 dCi , 2.0, 2.0 dCi		<b>F8-7989</b> ⊕
Control Arm-/Trailing Arm Bush	1.5 dCi , 1.6, 1.9 dCi , 2.0, 2.0 dCi		<b>F8-7992</b> ⊕
Engine Mounting	1.6		<b>F8-8168</b> ⊕
<b>GRAND SCÉNIC III (JZ0/1_)</b>		<b>02/2009 →</b>	
Alternator Freewheel Clutch	2.0 16V		<b>F5-1025</b>
Alternator Freewheel Clutch	1.5 dCi		<b>F5-1061</b>
Alternator Freewheel Clutch	1.9 dCi		<b>F5-1063</b>
Alternator Freewheel Clutch	1.2 TCe, 1.6 dCi , 1.9 dCi		<b>F5-1110</b>
Alternator Freewheel Clutch	1.5 dCi, 1.6 16V , 1.6 16V Bifuel		<b>F5-1122</b>
Alternator Freewheel Clutch	1.2 TCe, 1.4 16V , 1.6 dCi , 2.0 dCi		<b>F5-1129</b>
Anti-Friction Bearing	1.4 16V , 1.5 dCi, 1.9 dCi, 2.0 16V , 2.0 dCi		<b>F8-7637</b> ⊕ ⊕ H=34; d=99; D1=140; D2=108
<b>KANGOO (KC0/1_)</b>		<b>08/1997 → 06/2010</b>	
Dust Cover Kit, shock absorber	1.2, 1.2 16V , 1.4, 1.5 dCi, 1.6, 1.6 16V, 1.6 16V 4x4 , 1.6 16V bivalent, 1.9 dCi 4x4, 1.9 dTi , D 55 1.9 , D 65 1.9		<b>AK-735257</b> ⊕ ⊕
Alternator Freewheel Clutch	1.9 dCi 4x4 , 1.9 dTi		<b>F5-1014</b>
Alternator Freewheel Clutch	1.4, 1.5 dCi, 1.6, 1.6 16V, 1.6 16V 4x4 , 1.6 16V bivalent		<b>F5-1061</b>
Alternator Freewheel Clutch	1.5 dCi		<b>F5-1083</b>
Anti-Friction Bearing	All Models		<b>F8-3032</b> ⊕ H=9; d1=16; d2=27; D=56
Stabiliser Set	1.2, 1.2 16V , 1.4, 1.5 dCi , 1.6 16V, 1.6 16V 4x4 , 1.9 dCi 4x4, 1.9 dTi , D 55 1.9 , D 65 1.9		<b>F8-5087</b> ⊕
Control Arm-/Trailing Arm Bush	1.2, 1.4, 1.9 dTi , D 55 1.9 , D 65 1.9		<b>F8-5253</b> ⊕ ⊕ H=46; D1=45; D2=59
Engine Mounting	1.4		<b>F8-5349</b> ⊕
Engine Mounting	1.9 dTi		<b>F8-5480</b> ⊕
Mounting, automatic transmission	1.2, 1.4, 1.9 dTi , D 55 1.9 , D 65 1.9		<b>F8-5485</b>
Engine Mounting	1.4, 1.6, 1.6 16V, 1.6 16V 4x4 , 1.9 RXED, D 55 1.9 , D 65 1.9		<b>F8-5487</b> ⊕
Spring Cap	1.2, 1.2 16V , 1.4, 1.5 dCi, 1.6, 1.6 16V, 1.6 16V 4x4 , 1.9 dCi 4x4, 1.9 dTi , 1.9 RXED, D 55 1.9 , D 65 1.9		<b>F8-5488</b> ⊕ ⊕
Spring Cap	1.5 dCi	K9K 700	<b>F8-5488</b> ⊕ ⊕

<b>AK-735257</b>	<b>F5-1014</b>	<b>F5-1025</b>	<b>F5-1061</b>	<b>F5-1063</b>	<b>F5-1083</b>	<b>F5-1110</b>
Ref.Nr.: 7700802667	Ref.Nr.: 8641982	Ref.Nr.: 23151-00Q0B	Ref.Nr.: 7700110616	Ref.Nr.:	Ref.Nr.:	Ref.Nr.: 8200489514
<b>F5-1122</b>	<b>F5-1129</b>	<b>F8-3032</b>	<b>F8-5087</b>	<b>F8-5253</b>	<b>F8-5349</b>	<b>F8-5480</b>
Ref.Nr.:	Ref.Nr.: 23151-JG71B	Ref.Nr.: 8200651172	Ref.Nr.: 54616-00QAA	Ref.Nr.: 77 00 419 236	Ref.Nr.: 7700800522	Ref.Nr.: 7700805123
<b>F8-5485</b>	<b>F8-5487</b>	<b>F8-5488</b>	<b>F8-5496</b>	<b>F8-7093</b>	<b>F8-7637</b>	<b>F8-7657</b>
Ref.Nr.: 7700788318	Ref.Nr.: 7700434370	Ref.Nr.: 7700828866	Ref.Nr.: 7700829529	Ref.Nr.: 8200457775	Ref.Nr.: 543250005R	Ref.Nr.: 1230300Q0A

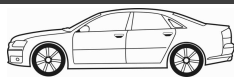

**Article Description****Article Nr.****Fitting Position**

<b>KANGOO (KC0/1_)</b>			<b>08/1997 → 06/2010</b>	
Top Strut Mounting	1.2, 1.4, D 55 1.9, D 65 1.9	03/1998 →;	<b>F8-5496</b>	
Top Strut Mounting	1.2 16V, 1.5 dCi, 1.6, 1.6 16V, 1.6 16V 4x4, 1.6 16V bivalent, 1.9 dCi 4x4, 1.9 dTi, 1.9 RXED, Electroad RE		<b>F8-5496</b>	
Belt Pulley, crankshaft	1.9 RXED, D 55 1.9, D 65 1.9		<b>F8-5645</b>	
Belt Pulley, crankshaft	1.9 dCi 4x4	F9Q 782	<b>F8-5656</b>	
Belt Pulley, crankshaft	1.9 dTi		<b>F8-5656</b>	
Belt Pulley, crankshaft	1.5 dCi		<b>F8-5657</b>	
Belt Pulley, crankshaft	1.5 dCi	04/2004 →	<b>F8-5657</b>	
Rubber Buffer, suspension	1.2, 1.2 16V, 1.4, 1.5 dCi, 1.6 16V, 1.6 16V 4x4, 1.9 dCi 4x4, 1.9 dTi, D 55 1.9, D 65 1.9		<b>F8-5863</b>	
Repair Set, axle beam	1.2, 1.2 16V, 1.4, 1.5 dCi, 1.6, D 55 1.9, D 65 1.9		<b>F8-6097</b>	
Gear, camshaft	1.9 dCi 4x4	F9Q 782; Engine Management: Timing Belt;  40	<b>F8-6254</b>	d=13; D=120; W=30
Gear, camshaft	1.9 dTi	Engine Management: Timing Belt;  40	<b>F8-6254</b>	d=13; D=120; W=30
Top Strut Mounting	All Models		<b>F8-6329</b>	
Engine Mounting	1.9 dCi 4x4	F9Q 782; Aluminium	<b>F8-6482</b>	
Engine Mounting	D 55 1.9		<b>F8-6484</b>	
Engine Mounting	D 65 1.9	F8Q 630	<b>F8-6484</b>	
Mounting, axle beam	1.2, 1.2 16V, 1.4, 1.5 dCi, 1.6, 1.6 16V, 1.6 16V 4x4, 1.6 16V bivalent, 1.9 dCi 4x4, 1.9 dTi, 1.9 RXED, D 55 1.9, D 65 1.9		<b>F8-6669</b>	H=35; d=48; D=77
Belt Pulley, crankshaft	1.6 16V	03/2003 →; Number of Ribs: 6	<b>F8-7094</b>	Belt Pulley Ø [mm]=134; Mounting points diam.[mm]=26; W=33
Belt Pulley, crankshaft	1.6 16V 4x4	01/2002 →; Number of Ribs: 6	<b>F8-7094</b>	Belt Pulley Ø [mm]=134; Mounting points diam.[mm]=26; W=33
Belt Pulley, crankshaft	1.6 16V bivalent	Number of Ribs: 6	<b>F8-7094</b>	Belt Pulley Ø [mm]=134; Mounting points diam.[mm]=26; W=33
Bearing, drive shaft	1.2, 1.4, D 55 1.9, D 65 1.9		<b>F8-7173</b>	d=25.8
Spring Cap	All Models		<b>F8-7450</b>	
Repair Kit, suspension strut	1.2	D7F 720, D7F 722, D7F 726, D7F 746;  with mounting parts	<b>F8-8088</b>	
Repair Kit, suspension strut	1.2 16V, 1.4, 1.5 dCi, 1.6, 1.6 16V, 1.6 16V 4x4, 1.9 dCi 4x4, 1.9 dTi, 1.9 RXED, D 55 1.9, D 65 1.9, Electroad RE	with mounting parts	<b>F8-8088</b>	
Repair Kit, suspension strut	1.5 dCi	K9K 700, K9K702;  with mounting parts	<b>F8-8088</b>	
Repair Kit, suspension strut	1.5 dCi	K9K 700;  with mounting parts	<b>F8-8088</b>	

<b>F8-5496</b>	<b>F8-5645</b>	<b>F8-5656</b>	<b>F8-5657</b>	<b>F8-5863</b>	<b>F8-6097</b>	<b>F8-6254</b>
Ref.Nr.: 7700829529	Ref.Nr.: 7700724249	Ref.Nr.: 7700115309	Ref.Nr.: 8200185800	Ref.Nr.: 7700428440	Ref.Nr.: 7701464321	Ref.Nr.: 8200125710
<b>F8-6329</b>	<b>F8-6482</b>	<b>F8-6484</b>	<b>F8-6669</b>	<b>F8-7094</b>	<b>F8-7173</b>	<b>F8-7450</b>
Ref.Nr.: 7700829529	Ref.Nr.: 82 00 148 388	Ref.Nr.: 77 00 426 193	Ref.Nr.: 7700809945	Ref.Nr.: 8200392683	Ref.Nr.: 7664079	Ref.Nr.: 7700415728
<b>F8-8088</b>						
Ref.Nr.: 7700798900						

Article Description

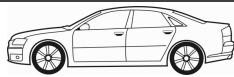

Article Nr.

Fitting Position



<b>KANGOO (KC0/1_)</b>			<b>08/1997 → 06/2010</b>	
Repair Kit, suspension strut	1.6 16V bivalent	K4M 750; , with mounting parts	<b>F8-8088</b>	
Engine Mounting	1.2 16V, 1.5 dCi		<b>F8-8138</b>	
Engine Mounting	1.5 dCi		<b>F8-8151</b>	
Engine Mounting	1.5 dCi, 1.9 dCi 4x4		<b>F8-8172</b>	
Engine Mounting	1.2, 1.2 16V, 1.5 dCi		<b>F8-8188</b>	
Bellow, steering	1.2, 1.2 16V, 1.4, 1.5 dCi, 1.6, 1.6 16V, 1.6 16V 4x4, 1.6 16V bivalent, 1.9 dCi 4x4, 1.9 dTi, 1.9 RXED, D 55 1.9, D 65 1.9	with clamps;	<b>LM-10000S</b>	
				d1=9; d2=39; L [mm]=168
<b>KANGOO Express (FC0/1_)</b>			<b>08/1997 → 06/2003</b>	
Dust Cover Kit, shock absorber	1.2, 1.2 16V, 1.4, 1.5 dCi, 1.6 16V, 1.6 16V 4x4, 1.9 dCi, 1.9 dCi 4x4, 1.9 dTi, D 55 1.9, D 65 1.9		<b>AK-735257</b>	
Alternator Freewheel Clutch	1.9 dCi, 1.9 dCi 4x4, 1.9 dTi		<b>F5-1014</b>	
Alternator Freewheel Clutch	1.4, 1.5 dCi, 1.6 16V 4x4, 1.6 16V bivalent		<b>F5-1061</b>	
Alternator Freewheel Clutch	1.5 dCi		<b>F5-1083</b>	
Anti-Friction Bearing	1.0, 1.2, 1.2 16V, 1.4, 1.5 dCi, 1.6 16V, 1.6 16V 4x4, 1.6 16V bivalent, 1.9 D, 1.9 dCi, 1.9 dCi 4x4, 1.9 dTi, D 55 1.9, D 65 1.9		<b>F8-3032</b>	H=9; d1=16; d2=27; D=56
Stabiliser Set	1.2, 1.2 16V, 1.4, 1.5 dCi, 1.6 16V, 1.6 16V 4x4, 1.9 dCi 4x4, 1.9 dTi, D 55 1.9, D 65 1.9		<b>F8-5087</b>	
Control Arm-/Trailing Arm Bush	1.2, 1.4, 1.9 dTi, D 55 1.9, D 65 1.9		<b>F8-5253</b>	H=46; D1=45; D2=59
Engine Mounting	1.4		<b>F8-5349</b>	
Engine Mounting	1.9 dTi		<b>F8-5480</b>	
Mounting, automatic transmission	1.2, 1.4, 1.9 dTi, D 55 1.9, D 65 1.9		<b>F8-5485</b>	
Engine Mounting	1.4, 1.6 16V, 1.6 16V 4x4, 1.9 D, D 55 1.9, D 65 1.9		<b>F8-5487</b>	
Spring Cap	1.0, 1.2, 1.4, 1.5 dCi, 1.6 16V, 1.6 16V 4x4, 1.9 D, 1.9 dCi, 1.9 dCi 4x4, 1.9 dTi, D 55 1.9		<b>F8-5488</b>	
Spring Cap	1.2	D7F 746	<b>F8-5488</b>	
Spring Cap	1.2 16V	D4F712	<b>F8-5488</b>	
Spring Cap	1.9 dCi 4x4	F9Q 790	<b>F8-5488</b>	
Spring Cap	D 65 1.9	F8Q 630	<b>F8-5488</b>	
Top Strut Mounting	1.0, 1.2, 1.2 16V, 1.5 dCi, 1.6 16V, 1.6 16V 4x4, 1.6 16V bivalent, 1.9 D, 1.9 dCi, 1.9 dCi 4x4, 1.9 dTi		<b>F8-5496</b>	
Top Strut Mounting	1.2, 1.4, D 55 1.9, D 65 1.9	03/1998 →;	<b>F8-5496</b>	
Belt Pulley, crankshaft	1.9 D, D 55 1.9, D 65 1.9		<b>F8-5645</b>	
Belt Pulley, crankshaft	1.9 dTi		<b>F8-5656</b>	
Belt Pulley, crankshaft	1.5 dCi		<b>F8-5657</b>	
Belt Pulley, crankshaft	1.5 dCi	04/2004 →	<b>F8-5657</b>	

<b>AK-735257</b>	<b>F5-1014</b>	<b>F5-1061</b>	<b>F5-1083</b>	<b>F8-3032</b>	<b>F8-5087</b>	<b>F8-5253</b>
Ref.Nr.: 7700802667	Ref.Nr.: 8641982	Ref.Nr.: 7700110616	Ref.Nr.:	Ref.Nr.: 8200651172	Ref.Nr.: 54616-00QAA	Ref.Nr.: 77 00 419 236
<b>F8-5349</b>	<b>F8-5480</b>	<b>F8-5485</b>	<b>F8-5487</b>	<b>F8-5488</b>	<b>F8-5496</b>	<b>F8-5645</b>
Ref.Nr.: 7700800522	Ref.Nr.: 7700805123	Ref.Nr.: 7700788318	Ref.Nr.: 7700434370	Ref.Nr.: 7700828866	Ref.Nr.: 7700829529	Ref.Nr.: 7700724249
<b>F8-5656</b>	<b>F8-5657</b>	<b>F8-8088</b>	<b>F8-8138</b>	<b>F8-8151</b>	<b>F8-8172</b>	<b>F8-8188</b>
Ref.Nr.: 7700115309	Ref.Nr.: 8200185800	Ref.Nr.: 7700798900	Ref.Nr.: 8200155207	Ref.Nr.: 8200151995	Ref.Nr.: 8200170362	Ref.Nr.: 11270-00QAA

**Article Description****Article Nr.****Fitting Position**

<b>KANGOO Express (FC0/1)</b>			<b>08/1997 → 06/2003</b>	
Belt Pulley, crankshaft	1.5 dCi	07/2003 →	<b>F8-5657</b>	
Rubber Buffer, suspension	1.2, 1.2 16V, 1.4, 1.5 dCi, 1.6 16V, 1.6 16V 4x4, 1.9 dCi 4x4, 1.9 dTi, D 55 1.9, D 65 1.9		<b>F8-5863</b>	
Repair Set, axle beam	1.2, 1.2 16V, 1.4, 1.5 dCi, 1.9 D, 1.9 dCi, 1.9 dCi 4x4, 1.9 dTi, D 55 1.9, D 65 1.9		<b>F8-6097</b>	
Gear, camshaft	1.9 dCi 4x4	F9Q 782; Engine Management: Timing Belt;  40	<b>F8-6254</b>	d=13; D=120; W=30
Gear, camshaft	1.9 dTi	Engine Management: Timing Belt;  40	<b>F8-6254</b>	d=13; D=120; W=30
Top Strut Mounting	1.0, 1.2, 1.2 16V, 1.4, 1.5 dCi, 1.6 16V, 1.6 16V 4x4, 1.6 16V bivalent, 1.9 D, 1.9 dCi, 1.9 dCi 4x4, 1.9 dTi, D 55 1.9, D 65 1.9		<b>F8-6329</b>	
Engine Mounting	1.6 16V, 1.9 dCi	Aluminium	<b>F8-6482</b>	
Engine Mounting	1.9 dCi 4x4, 1.9 dTi	F9Q 782; Aluminium	<b>F8-6482</b>	
Engine Mounting	D 55 1.9		<b>F8-6484</b>	
Engine Mounting	D 65 1.9	F8Q 630	<b>F8-6484</b>	
Mounting, axle beam	1.0, 1.2, 1.2 16V, 1.4, 1.5 dCi, 1.6 16V, 1.6 16V 4x4, 1.9 D, 1.9 dCi, 1.9 dCi 4x4, 1.9 dTi, D 55 1.9, D 65 1.9		<b>F8-6669</b>	H=35; d=48; D=77
Belt Pulley, crankshaft	1.6 16V	03/2003 →; Number of Ribs: 6	<b>F8-7094</b>	Belt Pulley Ø [mm]=134; Mounting points diam.[mm]=26; W=33
Belt Pulley, crankshaft	1.6 16V 4x4	01/2002 →; Number of Ribs: 6	<b>F8-7094</b>	Belt Pulley Ø [mm]=134; Mounting points diam.[mm]=26; W=33
Bearing, drive shaft	1.2, 1.4, D 55 1.9, D 65 1.9		<b>F8-7173</b>	d=25.8
Spring Cap	All Models		<b>F8-7450</b>	
Repair Kit, suspension strut	1.0, 1.2, 1.2 16V, 1.4, 1.5 dCi, 1.6 16V, 1.6 16V 4x4, 1.6 16V bivalent, 1.9 D, 1.9 dCi 4x4, 1.9 dTi, D 55 1.9	, with mounting parts	<b>F8-8088</b>	
Repair Kit, suspension strut	1.2 BiFuel	D7F 710; , with mounting parts	<b>F8-8088</b>	
Repair Kit, suspension strut	1.5 dCi	K9K704; , with mounting parts	<b>F8-8088</b>	
Repair Kit, suspension strut	1.9 dCi	F9Q 790; , with mounting parts	<b>F8-8088</b>	
Repair Kit, suspension strut	D 65 1.9	F8Q 630; , with mounting parts	<b>F8-8088</b>	
Engine Mounting	1.2 16V, 1.5 dCi		<b>F8-8138</b>	
Engine Mounting	1.5 dCi		<b>F8-8151</b>	
Engine Mounting	1.5 dCi, 1.9 dCi, 1.9 dCi 4x4		<b>F8-8172</b>	
Engine Mounting	1.0, 1.2, 1.2 16V, 1.2 BiFuel, 1.5 dCi, 1.6 16V, D 55 1.9		<b>F8-8188</b>	
Bellow, steering	1.2, 1.5 dCi	with clamps	<b>LM-10000S</b>	d1=9; d2=39; L [mm]=168

<b>AK-735446</b>	<b>F8-5657</b>	<b>F8-5863</b>	<b>F8-6097</b>	<b>F8-6254</b>	<b>F8-6329</b>	<b>F8-6482</b>
Ref.Nr.: 8200591288	Ref.Nr.: 8200185800	Ref.Nr.: 7700428440	Ref.Nr.: 7701464321	Ref.Nr.: 8200125710	Ref.Nr.: 7700829529	Ref.Nr.: 82 00 148 388
<b>F8-6484</b>	<b>F8-6669</b>	<b>F8-7094</b>	<b>F8-7173</b>	<b>F8-7450</b>	<b>F8-8088</b>	<b>F8-8138</b>
Ref.Nr.: 77 00 426 193	Ref.Nr.: 7700809945	Ref.Nr.: 8200392683	Ref.Nr.: 7664079	Ref.Nr.: 7700415728	Ref.Nr.: 7700798900	Ref.Nr.: 8200155207
<b>F8-8151</b>	<b>F8-8172</b>	<b>F8-8188</b>	<b>LM-10000S</b>			
Ref.Nr.: 8200151995	Ref.Nr.: 8200170362	Ref.Nr.: 11270-00QAA	Ref.Nr.: 6000025546			

Article Description



Article Nr.

Fitting Position



<b>KANGOO / GRAND KANGOO (KW0/1_)</b>			<b>02/2008 →</b>	
Dust Cover Kit, shock absorber	1.5 dCi , 1.6		<b>AK-735446</b>	
Alternator Freewheel Clutch	1.6 16V		<b>F5-1061</b>	
Alternator Freewheel Clutch	1.5 dCi, 1.5 dCi 110		<b>F5-1122</b>	
Belt Pulley, crankshaft	1.5 dCi		<b>F8-5657</b>	
Mounting, axle beam	1.5 dCi , 1.6 , 1.6 16V , 1.6 16V Hi-Flex		<b>F8-6670</b>	
Anti-Friction Bearing	1.5 dCi , 1.6 , 1.6 16V		<b>F8-7152</b>	
Top Strut Mounting	1.5 dCi		<b>F8-7449</b>	
Top Strut Mounting	1.5 dCi , 1.6		<b>F8-7635</b>	
Control Arm-/Trailing Arm Bush	1.5 dCi , 1.5 dCi 110, 1.6 , 1.6 16V , 1.6 16V Hi-Flex		<b>F8-7989</b>	d=12; D=24, 58; Thick. [mm]=53
Engine Mounting	1.6 , 1.6 16V , 1.6 16V Hi-Flex		<b>F8-8168</b>	
<b>KANGOO BE BOP (KW0/1_)</b>			<b>02/2009 →</b>	
Dust Cover Kit, shock absorber	1.5 dCi, 1.6		<b>AK-735446</b>	
Alternator Freewheel Clutch	1.6		<b>F5-1061</b>	
Alternator Freewheel Clutch	1.5 dCi , 1.5 dCi 75		<b>F5-1122</b>	
Mounting, axle beam	1.5 dCi , 1.6		<b>F8-6670</b>	
Anti-Friction Bearing	1.5 dCi , 1.6		<b>F8-7152</b>	
Top Strut Mounting	1.5 dCi, 1.6		<b>F8-7635</b>	
Control Arm-/Trailing Arm Bush	All Models		<b>F8-7989</b>	d=12; D=24, 58; Thick. [mm]=53
Engine Mounting	1.6		<b>F8-8168</b>	
<b>KANGOO Express (FW0/1_)</b>			<b>02/2008 →</b>	
Dust Cover Kit, shock absorber	1.5 dCi , 1.5 dCi 85 , 1.5 dCi 90 , 1.6, 1.6 16V, 1.6 16V LPG		<b>AK-735446</b>	
Alternator Freewheel Clutch	1.6 16V, 1.6 16V LPG		<b>F5-1061</b>	
Alternator Freewheel Clutch	1.5 dCi , 1.5 dCi 110, 1.5 dCi 75, 1.5 dCi 85 , 1.5 dCi 90		<b>F5-1122</b>	
Belt Pulley, crankshaft	1.5 dCi 85 , 1.5 dCi 90		<b>F8-5657</b>	
Belt Pulley, crankshaft	1.6 16V		<b>F8-5657</b>	
Mounting, axle beam	1.5 dCi, 1.5 dCi 85 , 1.6, 1.6 16V		<b>F8-6670</b>	
Anti-Friction Bearing	1.5 dCi , 1.5 dCi 85 , 1.5 dCi 90 , 1.6, 1.6 16V, 1.6 16V LPG, Z.E.		<b>F8-7152</b>	
Top Strut Mounting	1.5 dCi , 1.5 dCi 85 , 1.5 dCi 90 , 1.6, 1.6 16V, 1.6 16V LPG, Z.E.		<b>F8-7635</b>	
Control Arm-/Trailing Arm Bush	1.5 dCi , 1.5 dCi 110, 1.5 dCi 75, 1.5 dCi 85 , 1.5 dCi 90 , 1.6, 1.6 16V, 1.6 16V LPG, Z.E.		<b>F8-7989</b>	d=12; D=24, 58; Thick. [mm]=53
Engine Mounting	1.6, 1.6 16V, 1.6 16V LPG, Z.E.		<b>F8-8168</b>	

<b>AK-735446</b>	<b>F5-1061</b>	<b>F5-1116</b>	<b>F5-1122</b>	<b>F8-5657</b>	<b>F8-6670</b>	<b>F8-7152</b>
Ref.Nr.: 8200591288	Ref.Nr.: 7700110616	Ref.Nr.: 265031900	Ref.Nr.:	Ref.Nr.: 8200185800	Ref.Nr.: 8200380965	Ref.Nr.: 54325-AX000
<b>F8-7449</b>	<b>F8-7635</b>	<b>F8-7989</b>	<b>F8-8168</b>			
Ref.Nr.: 7700419475	Ref.Nr.: 8200591283	Ref.Nr.: 8200041166	Ref.Nr.: 8200014931			

**Article Description****Article Nr.****Fitting Position****KOLEOS (HY\_)****09/2008 →**

Alternator Freewheel Clutch	2.5, 2.5 4x4		<b>F5-1116</b>		
Alternator Freewheel Clutch	2.0 dCi, 2.0 dCi 4x4		<b>F5-1129</b>		

**LAGUNA I (B56\_, 556\_)****11/1993 → 03/2001**

Dust Cover Kit, shock absorber	1.6 16V, 1.8, 1.8 16V, 1.9 dCi, 1.9 dTi, 2.0, 2.0 16V, 2.2 D, 2.2 dT, 3.0, 3.0 24V		<b>AK-735042</b>				
Alternator Freewheel Clutch	1.9 dTi		<b>F5-1014</b>				
Alternator Freewheel Clutch	1.9 dCi		<b>F5-1025</b>				
Alternator Freewheel Clutch	1.6 16V		<b>F5-1029</b>				
Alternator Freewheel Clutch	1.6 16V		<b>F5-1061</b>				
Anti-Friction Bearing	1.6 16V, 1.8, 1.8 16V, 1.9 dCi, 1.9 dTi, 2.0, 2.0 16V, 2.2 D, 2.2 dT, 3.0, 3.0 24V		<b>F8-3012</b>				H=20; d=66; D=100
Anti-Friction Bearing	1.6 16V, 1.8 16V, 2.0, 2.0 16V		<b>F8-3033</b>				H=20; d1=62; d2=64; D=100
Engine Mounting	2.0, 2.0 16V		<b>F8-5464</b>				
Engine Mounting	2.2 D	01/1994 →	<b>F8-5464</b>				
Top Strut Mounting	1.8, 2.0, 2.2 D, 3.0	02/1994 →;	<b>F8-5474</b>				
Top Strut Mounting	1.8, 2.0 16V		<b>F8-5474</b>				
Top Strut Mounting	1.8, 2.0, 2.2 D, 3.0	02/1994 →;	<b>F8-5475</b>				
Top Strut Mounting	1.8, 2.0 16V		<b>F8-5475</b>				
Mounting, automatic transmission	1.8, 1.8 16V, 2.0, 2.0 16V		<b>F8-5478</b>				
Engine Mounting	1.6 16V, 1.8, 1.8 16V, 1.9 dCi, 1.9 dTi, 2.0, 2.0 16V, 2.2 D, 2.2 dT, 3.0, 3.0 24V		<b>F8-5489</b>				
Belt Pulley, crankshaft	2.2 D, 2.2 dT		<b>F8-5648</b>				
Belt Pulley, crankshaft	1.9 dTi		<b>F8-5656</b>				
Mounting, axle beam	1.6 16V, 1.8, 1.8 16V, 1.9 dCi, 1.9 dTi, 2.0, 2.0 16V, 2.2 D, 2.2 dT, 3.0, 3.0 24V		<b>F8-6079</b>				H1=73; H2=37; d=32; D1=72; D2=40
Mounting, axle beam	1.8	F3P720	<b>F8-6079</b>				H1=73; H2=37; d=32; D1=72; D2=40
Gear, camshaft	1.9 dTi	10/2000 →;  F9Q 710; Engine Management: Timing Belt;  40	<b>F8-6254</b>				d=13; D=120; W=30
Engine Mounting	1.6 16V	K4M 724	<b>F8-6488</b>				
Engine Mounting	1.8 16V, 1.9 dTi		<b>F8-6488</b>				
Engine Mounting	1.8	F3P720	<b>F8-6502</b>				
Engine Mounting	1.8	F3P724	<b>F8-6502</b>				
Engine Mounting	1.8	F3R722;	<b>F8-6502</b>				
Engine Mounting	1.8, 2.0		<b>F8-6502</b>				
Engine Mounting	2.0		<b>F8-6502</b>				
Engine Mounting	2.0	F3R722, F3R723	<b>F8-6502</b>				

<b>AK-735042</b>	<b>F5-1014</b>	<b>F5-1025</b>	<b>F5-1029</b>	<b>F5-1061</b>	<b>F5-1116</b>	<b>F5-1129</b>
Ref.Nr.: 7700776743	Ref.Nr.: 8641982	Ref.Nr.: 23151-00Q0B	Ref.Nr.: 7700110616	Ref.Nr.: 7700110616	Ref.Nr.: 265031900	Ref.Nr.: 23151-JG71B
<b>F8-3012</b>	<b>F8-3033</b>	<b>F8-5464</b>	<b>F8-5474</b>	<b>F8-5475</b>	<b>F8-5478</b>	<b>F8-5489</b>
Ref.Nr.: 503527	Ref.Nr.: 7700797666	Ref.Nr.: 7700818369	Ref.Nr.: 7700832420	Ref.Nr.: 7700832419	Ref.Nr.: 7700818372	Ref.Nr.: 7700414099
<b>F8-5648</b>	<b>F8-5656</b>	<b>F8-6079</b>	<b>F8-6254</b>	<b>F8-6488</b>	<b>F8-6502</b>	<b>F8-6906</b>
Ref.Nr.: 7700104292	Ref.Nr.: 7700115309	Ref.Nr.: 95FB-5C485-AA	Ref.Nr.: 8200125710	Ref.Nr.: 77 00 422 529	Ref.Nr.: 77 00 817 782	Ref.Nr.: 7700411189

Article Description



Article Nr.

Fitting Position



<b>LAGUNA I (B56, 556)</b>			<b>11/1993 → 03/2001</b>	
Engine Mounting	1.9 dCi, 3.0 24V	Aluminium	<b>F8-6906</b>	L=130
Engine Mounting	2.2 dT	04/1998 →; Aluminium	<b>F8-6906</b>	L=130
Belt Pulley, crankshaft	2.2 D	03/1994 →; Number of Ribs: 6	<b>F8-7090</b>	Belt Pulley Ø [mm]=137; W=40
Belt Pulley, crankshaft	1.6 16V	05/1998 →; Number of Ribs: 6	<b>F8-7094</b>	Belt Pulley Ø [mm]=134; Mounting points diam.[mm]=26; W=33
Belt Pulley, crankshaft	2.0		<b>F8-7654</b>	
Control Arm-/Trailing Arm Bush	1.6 16V, 1.8, 1.8 16V, 1.9 dCi, 1.9 dTi, 2.0, 2.0 16V, 2.2 D, 2.2 dT, 3.0, 3.0 24V		<b>G9-674</b>	H1=30; H2=55; d=18; D1=30; D2=55
Control Arm-/Trailing Arm Bush	1.6 16V, 1.8, 1.8 16V, 1.9 dCi, 1.9 dTi, 2.0, 2.0 16V, 2.2 D, 2.2 dT, 3.0, 3.0 24V		<b>G9-675</b>	H1=30; H2=55; d=12; D=59
Bellow, steering	1.6 16V, 1.8, 1.8 16V, 1.9 dCi, 1.9 dTi, 2.0, 2.0 16V, 2.2 D, 2.2 dT, 3.0, 3.0 24V	with clamps;	<b>LM-10036S</b>	d1=10; d2=37; L [mm]=155
<b>LAGUNA I Estate (K56)</b>			<b>09/1995 → 03/2001</b>	
Dust Cover Kit, shock absorber	1.6 16V, 1.8, 1.8 16V, 1.9 dCi, 1.9 dTi, 2.0, 2.0 16V, 2.2 D, 2.2 dT, 3.0, 3.0 24V		<b>AK-735042</b>	
Alternator Freewheel Clutch	1.9 dTi		<b>F5-1014</b>	
Alternator Freewheel Clutch	1.9 dCi		<b>F5-1025</b>	
Alternator Freewheel Clutch	1.6 16V		<b>F5-1029</b>	
Alternator Freewheel Clutch	1.6 16V		<b>F5-1061</b>	
Anti-Friction Bearing	All Models		<b>F8-3012</b>	H=20; d=66; D=100
Anti-Friction Bearing	1.6 16V, 1.8 16V, 1.9 dCi, 1.9 dTi, 3.0 24V		<b>F8-3033</b>	H=20; d1=62; d2=64; D=100
Engine Mounting	2.0 16V, 2.2 D	01/1996 →	<b>F8-5464</b>	
Engine Mounting	2.2 dT		<b>F8-5464</b>	
Top Strut Mounting	1.8, 2.0, 2.0 16V, 2.2 D	01/1996 →;	<b>F8-5474</b>	
Top Strut Mounting	1.8, 2.0, 2.0 16V, 2.2 D	01/1996 →;	<b>F8-5475</b>	
Mounting, automatic transmission	1.8, 1.8 16V, 2.0, 2.0 16V		<b>F8-5478</b>	
Engine Mounting	1.6 16V, 1.8, 1.8 16V, 1.9 dCi, 1.9 dTi, 2.0, 2.0 16V, 2.2 D, 2.2 dT, 3.0, 3.0 24V		<b>F8-5489</b>	
Belt Pulley, crankshaft	2.2 D, 2.2 dT		<b>F8-5648</b>	
Belt Pulley, crankshaft	1.9 dTi		<b>F8-5656</b>	
Mounting, axle beam	1.6 16V, 1.8, 1.8 16V, 1.9 dCi, 1.9 dTi, 2.0, 2.0 16V, 2.2 D, 2.2 dT, 3.0, 3.0 24V		<b>F8-6156</b>	H1=73; H2=37; d=32; D1=72; D2=40
Mounting, axle beam	1.8	F3P 678	<b>F8-6156</b>	H1=73; H2=37; d=32; D1=72; D2=40
Mounting, axle beam	2.0	F3R722, F3R723	<b>F8-6156</b>	H1=73; H2=37; d=32; D1=72; D2=40
Gear, camshaft	1.9 dTi	10/2000 →;  F9Q 710; Engine Management: Timing Belt;  40	<b>F8-6254</b>	d=13; D=120; W=30

<b>AK-735042</b>	<b>F5-1014</b>	<b>F5-1025</b>	<b>F5-1029</b>	<b>F5-1061</b>	<b>F8-3012</b>	<b>F8-3033</b>
Ref.Nr.: 7700776743	Ref.Nr.: 8641982	Ref.Nr.: 23151-00Q0B	Ref.Nr.: 7700110616	Ref.Nr.: 7700110616	Ref.Nr.: 503527	Ref.Nr.: 7700797666
<b>F8-5464</b>	<b>F8-5474</b>	<b>F8-5475</b>	<b>F8-5478</b>	<b>F8-5489</b>	<b>F8-5648</b>	<b>F8-5656</b>
Ref.Nr.: 7700818369	Ref.Nr.: 7700832420	Ref.Nr.: 7700832419	Ref.Nr.: 7700818372	Ref.Nr.: 7700414099	Ref.Nr.: 7700104292	Ref.Nr.: 7700115309
<b>F8-6156</b>	<b>F8-6254</b>	<b>F8-6488</b>	<b>F8-6906</b>	<b>F8-7090</b>	<b>F8-7094</b>	<b>F8-7654</b>
Ref.Nr.: 7700762844	Ref.Nr.: 8200125710	Ref.Nr.: 77 00 422 529	Ref.Nr.: 7700411189	Ref.Nr.: 7700858731	Ref.Nr.: 8200392683	Ref.Nr.: 7700109260

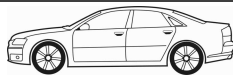
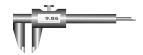
**Article Description****Article Nr.****Fitting Position**

<b>LAGUNA I Estate (K56)</b>				<b>09/1995 → 03/2001</b>	
Engine Mounting	1.6 16V	K4M 724	<b>F8-6488</b>		
Engine Mounting	1.8 16V		<b>F8-6488</b>		
Engine Mounting	1.9 dTi	F9Q 710, F9Q 716	<b>F8-6488</b>		
Engine Mounting	1.8	F3P 678	<b>F8-6502</b>		
Engine Mounting	1.8	F3P720	<b>F8-6502</b>		
Engine Mounting	2.0		<b>F8-6502</b>		
Engine Mounting	2.0		<b>F8-6502</b>		
Engine Mounting	1.9 dCi , 3.0 24V	Aluminium	<b>F8-6906</b>		L=130
Engine Mounting	2.2 dT	04/1998 →; Aluminium	<b>F8-6906</b>		L=130
Belt Pulley, crankshaft	2.2 D	Number of Ribs: 6	<b>F8-7090</b>		Belt Pulley Ø [mm]=137; W=40
Belt Pulley, crankshaft	1.6 16V	05/1998 →; Number of Ribs: 6	<b>F8-7094</b>		Belt Pulley Ø [mm]=134; Mounting points diam.[mm]=26; W=33
Belt Pulley, crankshaft	2.0		<b>F8-7654</b>		
Control Arm-/Trailing Arm Bush	1.9 dTi	F9Q 717	<b>F8-7988</b>	⊕ ⊕	
Control Arm-/Trailing Arm Bush	1.6 16V , 1.8 , 1.8 16V , 1.9 dCi , 1.9 dTi , 2.0 , 2.0 16V , 2.2 D , 2.2 dT , 3.0 , 3.0 24V		<b>G9-674</b>	⊕ ⊕	H1=30; H2=55; d=18; D1=30; D2=55
Control Arm-/Trailing Arm Bush	1.6 16V , 1.8 , 1.8 16V , 1.9 dCi , 1.9 dTi , 2.0 , 2.0 16V , 2.2 D , 2.2 dT , 3.0 , 3.0 24V		<b>G9-675</b>	⊕ ⊕	H1=30; H2=55; d=12; D=59
Bellow, steering	1.6 16V , 1.8 , 1.8 16V , 1.9 dCi , 1.9 dTi , 2.0 , 2.0 16V , 2.2 D , 2.2 dT , 3.0 , 3.0 24V	with clamps;	<b>LM-10036S</b>	⊕ ⊕	d1=10; d2=37; L [mm]=155
<b>LAGUNA II (BG0/1)</b>				<b>03/2001 → 10/2005</b>	
Dust Cover Kit, shock absorber	1.6 16V , 1.8 16V , 1.9 dCi , 2.0 16V , 2.0 16V IDE , 2.0 16V Turbo , 2.0 dCi , 2.2 dCi , 3.0 V6 24V		<b>AK-735060</b>	⊕ ⊕	
Alternator Freewheel Clutch	1.8 16V , 2.0 16V IDE		<b>F5-1014</b>		
Alternator Freewheel Clutch	1.9 dCi		<b>F5-1025</b>		
Alternator Freewheel Clutch	1.9 dCi		<b>F5-1036</b>		
Alternator Freewheel Clutch	1.6 16V		<b>F5-1061</b>		
Alternator Freewheel Clutch	1.9 dCi		<b>F5-1063</b>		
Alternator Freewheel Clutch	1.9 dCi		<b>F5-1093</b>		
Alternator Freewheel Clutch	2.0 dCi		<b>F5-1110</b>		
Alternator Freewheel Clutch	1.6 16V		<b>F5-1122</b>		
Top Strut Mounting	1.6 16V , 1.8 16V , 1.9 dCi , 2.0 16V , 2.0 16V IDE , 2.0 16V Turbo , 2.0 dCi , 2.2 dCi , 3.0 V6 24V		<b>F8-6177</b>	⊕ ⊕	
Top Strut Mounting	1.6 16V , 1.8 16V , 1.9 dCi , 2.0 16V , 2.0 16V IDE , 2.0 16V Turbo , 2.0 dCi , 2.2 dCi , 3.0 V6 24V		<b>F8-6332</b>		
Engine Mounting	1.9 dCi	without holder	<b>F8-6666</b>	⊕	
Engine Mounting	1.9 dCi , 2.2 dCi , 3.0 V6 24V		<b>F8-6667</b>	⊕ ↑	

<b>AK-735060</b>	<b>F5-1014</b>	<b>F5-1025</b>	<b>F5-1036</b>	<b>F5-1061</b>	<b>F5-1063</b>	<b>F5-1093</b>
Ref.Nr.: 7700833756	Ref.Nr.: 8641982	Ref.Nr.: 23151-00Q0B	Ref.Nr.: 23151-00Q0A	Ref.Nr.: 7700110616	Ref.Nr.:	Ref.Nr.:
<b>F5-1110</b>	<b>F5-1122</b>	<b>F8-6177</b>	<b>F8-6332</b>	<b>F8-6488</b>	<b>F8-6502</b>	<b>F8-6666</b>
Ref.Nr.: 8200489514	Ref.Nr.:	Ref.Nr.: 7700424481	Ref.Nr.: 8200002876	Ref.Nr.: 77 00 422 529	Ref.Nr.: 77 00 817 782	Ref.Nr.: 8200302003
<b>F8-6667</b>	<b>F8-6668</b>	<b>F8-6906</b>	<b>F8-7090</b>	<b>F8-7094</b>	<b>F8-7654</b>	<b>F8-7988</b>
Ref.Nr.: 8200250743	Ref.Nr.: 8200181589	Ref.Nr.: 7700411189	Ref.Nr.: 7700858731	Ref.Nr.: 8200392683	Ref.Nr.: 7700109260	Ref.Nr.: 8200002869

Article Description

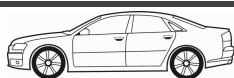

Article Nr.

Fitting Position



LAGUNA II (BG0/1_)			03/2001 → 10/2005	
Engine Mounting	1.6 16V, 1.8 16V, 1.9 dCi, 2.0 16V, 2.0 16V IDE, 2.0 16V Turbo, 2.0 dCi, 2.2 dCi, 3.0 V6 24V		F8-6668	
Engine Mounting	1.6 16V, 1.8 16V, 1.9 dCi, 2.0 16V, 2.0 16V IDE, 2.0 16V Turbo, 2.0 dCi, 2.2 dCi, 3.0 V6 24V		F8-6671	
Engine Mounting	1.6 16V, 1.8 16V, 1.9 dCi, 2.0 16V, 2.0 16V IDE, 2.0 16V Turbo, 2.0 dCi, 2.2 dCi, 3.0 V6 24V		F8-6672	
Engine Mounting	1.6 16V, 1.8 16V		F8-7009	
Engine Mounting	1.8 16V	5-speed,  4-speed,  6-speed; Type: BG0J, BG0M	F8-7009	
Engine Mounting	1.9 dCi, 2.0 16V	5-speed	F8-7009	
Engine Mounting	2.0 16V IDE	5-speed,  5-speed,  6-speed	F8-7009	
Belt Pulley, crankshaft	2.2 dCi	Number of Ribs: 6	F8-7092	
Belt Pulley, crankshaft	1.9 dCi	03/2005 →; Number of Ribs: 7	F8-7093	
Belt Pulley, crankshaft	1.9 dCi	Number of Ribs: 7	F8-7093	
Belt Pulley, crankshaft	1.6 16V	Number of Ribs: 6	F8-7094	
Supporting Ring, suspension strut bearing	1.6 16V, 1.8 16V, 1.9 dCi, 2.0 16V, 2.0 16V IDE, 2.0 16V Turbo, 2.0 dCi, 2.2 dCi, 3.0 V6 24V		F8-7469	
Anti-Friction Bearing	1.6 16V, 1.8 16V, 1.9 dCi, 2.0 16V, 2.0 16V IDE, 2.0 16V Turbo, 2.0 dCi, 2.2 dCi, 3.0 V6 24V		F8-7633	
Control Arm-/Trailing Arm Bush	1.6 16V, 1.8 16V, 1.9 dCi, 2.0 16V, 2.0 16V IDE, 2.0 dCi, 2.2 dCi, 3.0 V6 24V		F8-7988	
Control Arm-/Trailing Arm Bush	1.8 16V	F4P 771, F4P 773, F4P 774, F4P775	F8-7988	
Control Arm-/Trailing Arm Bush	1.9 dCi	F9Q 674	F8-7988	
Control Arm-/Trailing Arm Bush	2.0 16V Turbo	F4R 764, F4R 765	F8-7988	
Control Arm-/Trailing Arm Bush	2.2 dCi	G9T 600, G9T 605	F8-7988	
Control Arm-/Trailing Arm Bush	1.6 16V, 1.8 16V, 1.9 dCi, 2.0 16V, 2.0 16V IDE, 2.0 16V Turbo, 2.0 dCi, 2.2 dCi, 3.0 V6 24V		F8-7990	
Mounting, axle beam	All Models		F8-8227	H=73; D=78
Repair Set, axle beam	1.6 16V, 1.8 16V, 1.9 dCi, 2.0 16V, 2.0 16V IDE, 2.0 16V Turbo, 2.0 dCi, 2.2 dCi, 3.0 V6 24V		G8-559	

<b>AK-735060</b>	<b>F8-6668</b>	<b>F8-6671</b>	<b>F8-6672</b>	<b>F8-7009</b>	<b>F8-7092</b>	<b>F8-7093</b>
Ref.Nr.: 7700833756	Ref.Nr.: 8200181589	Ref.Nr.: 8200000514	Ref.Nr.: 8200000515	Ref.Nr.: 8200000002	Ref.Nr.: 8200207436	Ref.Nr.: 8200457775
<b>F8-7094</b>	<b>F8-7469</b>	<b>F8-7633</b>	<b>F8-7988</b>	<b>F8-7990</b>	<b>F8-8227</b>	<b>G8-559</b>
Ref.Nr.: 8200392683	Ref.Nr.: 7700424482	Ref.Nr.: 7700424481	Ref.Nr.: 8200002869	Ref.Nr.: 8200002868	Ref.Nr.: 8200427869	Ref.Nr.: 7701209534

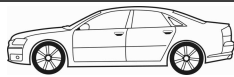

**Article Description****Article Nr.****Fitting Position**

<b>LAGUNA II Sport Tourer (KG0/1_)</b>			<b>03/2001 → 09/2007</b>	
Dust Cover Kit, shock absorber	1.6 16V, 1.6 FlexFuel, 1.8 16V, 1.9 dCi, 2.0, 2.0 16V, 2.0 16V IDE, 2.0 16V Turbo, 2.0 dCi, 2.2 dCi, 3.0 V6 24V	ST	<b>AK-735060</b>	
Alternator Freewheel Clutch	1.8 16V, 2.0 16V IDE		<b>F5-1014</b>	
Alternator Freewheel Clutch	1.9 dCi		<b>F5-1025</b>	
Alternator Freewheel Clutch	1.9 dCi		<b>F5-1036</b>	
Alternator Freewheel Clutch	1.6 16V, 1.6 FlexFuel		<b>F5-1061</b>	
Alternator Freewheel Clutch	1.9 dCi		<b>F5-1063</b>	
Alternator Freewheel Clutch	1.9 dCi		<b>F5-1093</b>	
Alternator Freewheel Clutch	2.0 dCi		<b>F5-1110</b>	
Alternator Freewheel Clutch	1.6 16V		<b>F5-1122</b>	
Top Strut Mounting	1.6 16V, 1.6 FlexFuel, 1.8 16V, 1.9 dCi, 2.0, 2.0 16V, 2.0 16V IDE, 2.0 16V Turbo, 2.0 dCi, 2.2 dCi, 3.0 V6 24V		<b>F8-6177</b>	
Top Strut Mounting	1.6 16V, 1.6 FlexFuel, 1.8 16V, 1.9 dCi, 2.0, 2.0 16V, 2.0 16V IDE, 2.0 16V Turbo, 2.0 dCi, 2.2 dCi, 3.0 V6 24V		<b>F8-6332</b>	
Engine Mounting	1.9 dCi	without holder	<b>F8-6666</b>	
Engine Mounting	1.9 dCi, 2.2 dCi, 3.0 V6 24V		<b>F8-6667</b>	
Engine Mounting	1.6 16V, 1.6 FlexFuel, 1.8 16V, 1.9 dCi, 2.0, 2.0 16V, 2.0 16V IDE, 2.0 16V Turbo, 2.0 dCi, 2.2 dCi, 3.0 V6 24V		<b>F8-6668</b>	
Engine Mounting	1.6 16V, 1.8 16V, 1.9 dCi, 2.0 16V, 2.0 16V IDE, 2.0 16V Turbo, 2.0 dCi, 2.2 dCi, 3.0 V6 24V		<b>F8-6671</b>	
Engine Mounting	1.6 16V, 1.8 16V, 1.9 dCi, 2.0 16V, 2.0 16V IDE, 2.0 16V Turbo, 2.0 dCi, 2.2 dCi, 3.0 V6 24V		<b>F8-6672</b>	
Engine Mounting	1.6 16V, 1.8 16V		<b>F8-7009</b>	
Engine Mounting	1.8 16V, 2.0 16V IDE	5-speed,  5-speed,  6-speed	<b>F8-7009</b>	
Engine Mounting	1.9 dCi, 2.0 16V	5-speed	<b>F8-7009</b>	
Belt Pulley, crankshaft	2.2 dCi	Number of Ribs: 6	<b>F8-7092</b>	Belt Pulley Ø [mm]=152; Mounting points diam.[mm]=30.6; W=45.5
Belt Pulley, crankshaft	1.9 dCi	03/2005 →; Number of Ribs: 7	<b>F8-7093</b>	Belt Pulley Ø [mm]=155; Mounting points diam.[mm]=25; W=41
Belt Pulley, crankshaft	1.9 dCi	Number of Ribs: 7	<b>F8-7093</b>	Belt Pulley Ø [mm]=155; Mounting points diam.[mm]=25; W=41
Belt Pulley, crankshaft	1.6 16V	Number of Ribs: 6	<b>F8-7094</b>	Belt Pulley Ø [mm]=134; Mounting points diam.[mm]=26; W=33

<b>AK-735060</b>	<b>F5-1014</b>	<b>F5-1025</b>	<b>F5-1036</b>	<b>F5-1061</b>	<b>F5-1063</b>	<b>F5-1093</b>
Ref.Nr.: 7700833756	Ref.Nr.: 8641982	Ref.Nr.: 23151-00Q0B	Ref.Nr.: 23151-00Q0A	Ref.Nr.: 7700110616	Ref.Nr.:	Ref.Nr.:
<b>F5-1110</b>	<b>F5-1122</b>	<b>F8-6177</b>	<b>F8-6332</b>	<b>F8-6666</b>	<b>F8-6667</b>	<b>F8-6668</b>
Ref.Nr.: 8200489514	Ref.Nr.:	Ref.Nr.: 7700424481	Ref.Nr.: 8200002876	Ref.Nr.: 8200302003	Ref.Nr.: 8200250743	Ref.Nr.: 8200181589
<b>F8-6671</b>	<b>F8-6672</b>	<b>F8-7009</b>	<b>F8-7092</b>	<b>F8-7093</b>	<b>F8-7094</b>	<b>F8-7469</b>
Ref.Nr.: 8200000514	Ref.Nr.: 8200000515	Ref.Nr.: 8200000002	Ref.Nr.: 8200207436	Ref.Nr.: 8200457775	Ref.Nr.: 8200392683	Ref.Nr.: 7700424482

Article Description



Article Nr.

Fitting Position



<b>LAGUNA II Sport Tourer (KG0/1)</b>			<b>03/2001 → 09/2007</b>	
Supporting Ring, suspension strut bearing	1.6 16V , 1.6 FlexFuel, 1.8 16V , 1.9 dCi , 2.0, 2.0 16V , 2.0 16V IDE , 2.0 16V Turbo , 2.0 dCi , 2.2 dCi , 3.0 V6 24V		<b>F8-7469</b>	
Anti-Friction Bearing	1.6 16V , 1.6 FlexFuel, 1.8 16V , 1.9 dCi , 2.0, 2.0 16V , 2.0 16V IDE , 2.0 16V Turbo , 2.0 dCi , 2.2 dCi , 3.0 V6 24V		<b>F8-7633</b>	
Control Arm-/Trailing Arm Bush	1.6 16V , 1.6 FlexFuel, 1.8 16V , 1.9 dCi, 2.0, 2.0 16V, 2.0 16V IDE , 2.0 16V Turbo , 2.0 dCi , 2.2 dCi , 3.0 V6 24V		<b>F8-7988</b>	
Control Arm-/Trailing Arm Bush	2.2 dCi	G9T 600	<b>F8-7988</b>	
Control Arm-/Trailing Arm Bush	1.6 16V , 1.6 FlexFuel, 1.8 16V , 1.9 dCi , 2.0, 2.0 16V , 2.0 16V IDE , 2.0 16V Turbo , 2.0 dCi , 2.2 dCi , 3.0 V6 24V		<b>F8-7990</b>	
Mounting, axle beam	All Models		<b>F8-8227</b>	H=73; D=78
Repair Set, axle beam	1.6 16V, 1.8 16V, 1.9 dCi , 2.0 16V, 2.0 16V IDE , 2.0 16V Turbo , 2.0 dCi , 2.2 dCi, 3.0 V6 24V		<b>G8-559</b>	
<b>LAGUNA III (BT0/1)</b>			<b>10/2007 →</b>	
Dust Cover Kit, shock absorber	1.5 dCi , 1.6 16V , 2.0 16V , 2.0 16V Hi-Flex , 2.0 16V Turbo, 2.0 dCi , 2.0 dCi GT , 2.0 GT, 3.0 dCi		<b>AK-735419</b>	
Alternator Freewheel Clutch	2.0 16V , 2.0 16V Hi-Flex		<b>F5-1025</b>	
Alternator Freewheel Clutch	2.0 dCi		<b>F5-1110</b>	
Alternator Freewheel Clutch	2.0 dCi , 2.0 dCi GT , 3.0 dCi		<b>F5-1129</b>	
Alternator Freewheel Clutch	1.5 dCi		<b>F5-1130</b>	
Anti-Friction Bearing	1.5 dCi , 1.6 16V , 2.0 16V , 2.0 16V Turbo, 2.0 dCi , 2.0 dCi GT , 2.0 GT, 3.5 V6		<b>F8-7637</b>	H=34; d=99; D1=140; D2=108
Belt Pulley, crankshaft	2.0 dCi	Number of Ribs: 6; Parameter: 7PK	<b>F8-7657</b>	
<b>LAGUNA Coupe (DT0/1)</b>			<b>09/2008 →</b>	
Dust Cover Kit, shock absorber	2.0 16V Turbo, 2.0 dCi , 2.0 dCi GT , 2.0 GT, 3.0 dCi , 3.5 V6		<b>AK-735419</b>	
Alternator Freewheel Clutch	1.5 dCi		<b>F5-1061</b>	
Alternator Freewheel Clutch	1.5 dCi		<b>F5-1122</b>	
Alternator Freewheel Clutch	2.0 dCi , 2.0 dCi GT , 3.0 dCi		<b>F5-1129</b>	
Anti-Friction Bearing	2.0 16V Turbo, 2.0 dCi , 2.0 dCi GT , 2.0 GT, 3.5 V6		<b>F8-7637</b>	H=34; d=99; D1=140; D2=108
Belt Pulley, crankshaft	2.0 dCi , 2.0 dCi GT	Number of Ribs: 6; Parameter: 7PK	<b>F8-7657</b>	
<b>LAGUNA III Sport Tourer (KT0/1)</b>			<b>10/2007 →</b>	
Dust Cover Kit, shock absorber	1.5 dCi , 1.6 16V , 2.0 16V , 2.0 16V Hi-Flex , 2.0 16V Turbo, 2.0 dCi , 2.0 dCi GT , 2.0 GT, 3.0 dCi		<b>AK-735419</b>	
Alternator Freewheel Clutch	2.0 16V , 2.0 16V Hi-Flex		<b>F5-1025</b>	
Alternator Freewheel Clutch	2.0 dCi		<b>F5-1110</b>	

<b>AK-735419</b>	<b>F5-1025</b>	<b>F5-1061</b>	<b>F5-1110</b>	<b>F5-1122</b>	<b>F5-1129</b>	<b>F5-1130</b>
Ref.Nr.: 540500001R	Ref.Nr.: 23151-00Q0B	Ref.Nr.: 7700110616	Ref.Nr.: 8200489514	Ref.Nr.:	Ref.Nr.: 23151-JG71B	Ref.Nr.: 23151-3VD1A
<b>F8-7469</b>	<b>F8-7633</b>	<b>F8-7637</b>	<b>F8-7657</b>	<b>F8-7988</b>	<b>F8-7990</b>	<b>F8-8227</b>
Ref.Nr.: 7700424482	Ref.Nr.: 7700424481	Ref.Nr.: 543250005R	Ref.Nr.: 1230300Q0A	Ref.Nr.: 8200002869	Ref.Nr.: 8200002868	Ref.Nr.: 8200427869
<b>G8-559</b>						
Ref.Nr.: 7701209534						

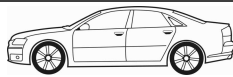
**Article Description****Article Nr.****Fitting Position**

<b>LAGUNA III Sport Tourer (KT0/1)</b>				<b>10/2007 →</b>	
Alternator Freewheel Clutch	2.0 dCi , 2.0 dCi GT , 3.0 dCi		<b>F5-1129</b>		
Alternator Freewheel Clutch	1.5 dCi		<b>F5-1130</b>		
Anti-Friction Bearing	1.5 dCi , 1.6 16V , 2.0 16V , 2.0 16V Turbo , 2.0 dCi , 2.0 dCi GT , 2.0 GT , 3.5 V6		<b>F8-7637</b>		H=34; d=99; D1=140; D2=108
Belt Pulley, crankshaft	2.0 dCi	Number of Ribs: 6; Parameter: 7PK	<b>F8-7657</b>		
<b>LATITUDE (L70_)</b>				<b>02/2011 →</b>	
Alternator Freewheel Clutch	2.0 16V , 2.0 16V eco2		<b>F5-1025</b>		
Alternator Freewheel Clutch	2.0 dCi , 2.0 dCi 150 , 2.0 dCi 175 , 3.0 dCi 240		<b>F5-1129</b>		
<b>LOGAN I (LS_)</b>				<b>09/2004 →</b>	
Alternator Freewheel Clutch	1.4, 1.5 dCi, 1.6		<b>F5-1061</b>		
Alternator Freewheel Clutch	1.6		<b>F5-1122</b>		
Anti-Friction Bearing	1.4, 1.5 dCi, 1.6		<b>F8-3032</b>		H=9; d1=16; d2=27; D=56
Top Strut Mounting	1.4, 1.5 dCi, 1.6		<b>F8-6339</b>		
Top Strut Mounting	1.4, 1.5 dCi, 1.6		<b>F8-6596</b>		
Mounting, axle beam	1.4, 1.5 dCi, 1.6		<b>F8-6597</b>		
Engine Mounting	1.4, 1.5 dCi, 1.6		<b>F8-6599</b>		L=125
Engine Mounting	1.4, 1.5 dCi, 1.6		<b>F8-6600</b>		
Stabiliser Mounting	1.4, 1.5 dCi, 1.6		<b>F8-6601</b>		d=23
Engine Mounting	1.4, 1.6		<b>F8-6711</b>		
Rubber Buffer, suspension	All Models		<b>F8-7900</b>		
Control Arm-/Trailing Arm Bush	1.4, 1.5 dCi, 1.6		<b>F8-7977</b>		
Engine Mounting	1.4, 1.5 dCi, 1.6		<b>F8-8157</b>		
<b>LOGAN I Estate (KS_)</b>				<b>04/2007 →</b>	
Alternator Freewheel Clutch	1.4, 1.5 dCi, 1.6		<b>F5-1061</b>		
Alternator Freewheel Clutch	1.6		<b>F5-1122</b>		
Anti-Friction Bearing	1.4, 1.5 dCi, 1.6		<b>F8-3032</b>		H=9; d1=16; d2=27; D=56
Belt Pulley, crankshaft	1.5 dCi		<b>F8-5657</b>		
Top Strut Mounting	1.4, 1.5 dCi, 1.6		<b>F8-6339</b>		
Top Strut Mounting	1.4, 1.5 dCi, 1.6		<b>F8-6596</b>		
Mounting, axle beam	1.4, 1.5 dCi, 1.6		<b>F8-6597</b>		
Engine Mounting	1.4, 1.5 dCi, 1.6		<b>F8-6599</b>		L=125
Engine Mounting	1.4, 1.5 dCi, 1.6		<b>F8-6600</b>		
Stabiliser Mounting	1.4, 1.5 dCi, 1.6		<b>F8-6601</b>		d=23
Engine Mounting	1.4, 1.6		<b>F8-6711</b>		

<b>F5-1025</b>	<b>F5-1061</b>	<b>F5-1122</b>	<b>F5-1129</b>	<b>F5-1130</b>	<b>F8-3032</b>	<b>F8-5657</b>
Ref.Nr.: 23151-00Q0B	Ref.Nr.: 7700110616	Ref.Nr.:	Ref.Nr.: 23151-JG71B	Ref.Nr.: 23151-3VD1A	Ref.Nr.: 8200651172	Ref.Nr.: 8200185800
<b>F8-6339</b>	<b>F8-6596</b>	<b>F8-6597</b>	<b>F8-6599</b>	<b>F8-6600</b>	<b>F8-6601</b>	<b>F8-6711</b>
Ref.Nr.: 8200307941	Ref.Nr.: 6001547499	Ref.Nr.: 6001549989	Ref.Nr.: 8200297939	Ref.Nr.: 8200395661	Ref.Nr.: 6001547140	Ref.Nr.: 112107695R
<b>F8-7637</b>	<b>F8-7657</b>	<b>F8-7900</b>	<b>F8-7977</b>	<b>F8-8157</b>		
Ref.Nr.: 543250005R	Ref.Nr.: 1230300Q0A	Ref.Nr.: 6001548402	Ref.Nr.: 6040002245	Ref.Nr.: 8200575641		

Article Description



Article Nr.

Fitting Position



<b>LOGAN I Estate (KS_)</b>		<b>04/2007 →</b>	
Rubber Buffer, suspension	All Models	<b>F8-7900</b>	⊕ ⊕
Control Arm-/Trailing Arm Bush	1.4, 1.5 dCi, 1.6	<b>F8-7977</b>	
Engine Mounting	1.4, 1.5 dCi, 1.6	<b>F8-8157</b>	
<b>MASTER I Bus (T_)</b>		<b>08/1980 → 07/1998</b>	
Stabiliser Mounting	28-35 2.5 TD, 28-35 2.0, 28-35 2.1 D, 28-35 2.4 D, 28-35 2.5 D, 30 2.2, 35 2.5 TD	<b>F8-5091</b>	⊕ ⊕ d=22
Mounting, leaf spring	28-35 2.5 TD, 28-35 2.0, 28-35 2.1 D, 28-35 2.5 D, 30 2.2, 35 2.5 TD	<b>F8-6685</b>	
Mounting, axle beam	All Models	<b>F8-6686</b>	H=80; d=22; D=47
Engine Mounting	28-35 2.0, 28-35 2.5 D	<b>F8-6688</b>	
Engine Mounting	28-35 2.5 TD, 28-35 2.0, 28-35 2.1 D, 28-35 2.5 D, 30 2.2, 35 2.5 TD	<b>F8-6848</b>	⊕ ⊕
Engine Mounting	28-35 2.0	11/1989 →	<b>F8-6848</b> ⊕ ⊕
<b>MASTER I Van (T_)</b>		<b>07/1980 → 07/1998</b>	
Stabiliser Mounting	28-35 2.5 D, 28-35 2.5 TD, 28-35 2.0, 28-35 2.1 D, 28-35 2.4 D, 30 2.2, 35 2.5 TD	<b>F8-5091</b>	⊕ ⊕ d=22
Mounting, leaf spring	28-35 2.5 TD, 28-35 2.0, 35 2.5 TD	<b>F8-6685</b>	
Mounting, axle beam	All Models	<b>F8-6686</b>	H=80; d=22; D=47
Engine Mounting	28-35 2.5 D, 28-35 2.0	<b>F8-6688</b>	
Engine Mounting	28-35 2.5 TD, 28-35 2.0, 35 2.5 TD	<b>F8-6848</b>	⊕ ⊕
Engine Mounting	28-35 2.0	11/1989 →	<b>F8-6848</b> ⊕ ⊕
Engine Mounting	30 2.2	08/1993 →	<b>F8-6848</b> ⊕ ⊕
<b>MASTER I Platform/Chassis (P_)</b>		<b>07/1980 → 07/1998</b>	
Stabiliser Mounting	28-35 2.0, 28-35 2.5 D	<b>F8-5091</b>	⊕ ⊕ d=22
Mounting, leaf spring	2.5 DT, 28-35 2.0, 28-35 2.5 D	<b>F8-6685</b>	
Mounting, axle beam	All Models	<b>F8-6686</b>	H=80; d=22; D=47
Engine Mounting	28-35 2.0, 28-35 2.5 D	<b>F8-6688</b>	
Engine Mounting	28-35 2.0	11/1989 →; Type: PC12, PL12	<b>F8-6848</b> ⊕ ⊕
Engine Mounting	28-35 2.0, 28-35 2.5 D		<b>F8-6848</b> ⊕ ⊕
<b>MASTER II Bus (JD)</b>		<b>07/1998 → 10/2001</b>	
Alternator Freewheel Clutch	1.9 dCi 80, 2.2 dCi 90, 2.5 dCi, 2.5 dCi 100, 2.5 dCi 120	<b>F5-1025</b>	
Alternator Freewheel Clutch	3.0 dCi 140	<b>F5-1035</b>	
Alternator Freewheel Clutch	1.9 dCi 80	<b>F5-1036</b>	
Alternator Freewheel Clutch	2.2 dCi 90, 2.5 dCi, 2.5 dCi 100	<b>F5-1063</b>	
Gear, camshaft	1.9 dTi	Engine Management: Timing Belt; ⚙ 40	<b>F8-6254</b> d=13; D=120; W=30

<b>F5-1025</b>	<b>F5-1035</b>	<b>F5-1036</b>	<b>F5-1063</b>	<b>F8-5091</b>	<b>F8-6254</b>	<b>F8-6524</b>
Ref.Nr.: 23151-00Q0B	Ref.Nr.: 23150-2W200	Ref.Nr.: 23151-00Q0A	Ref.Nr.:	Ref.Nr.: 5000387990	Ref.Nr.: 8200125710	Ref.Nr.: 8200027176
<b>F8-6685</b>	<b>F8-6686</b>	<b>F8-6688</b>	<b>F8-6848</b>	<b>F8-7900</b>	<b>F8-7977</b>	<b>F8-8157</b>
Ref.Nr.: 5000392656	Ref.Nr.: 5000392657	Ref.Nr.: 9110612	Ref.Nr.: 5000387455	Ref.Nr.: 6001548402	Ref.Nr.: 6040002245	Ref.Nr.: 8200575641



Article Description

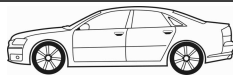

Article Nr.

Fitting Position



### MASTER II Bus (JD)

07/1998 → 10/2001

Engine Mounting	1.9 dCi 80, 1.9 dTi, 2.2 dCi 90, 2.5 dCi, 2.5 dCi 120, 3.0 dCi 140	for OE: 8200027176	<b>F8-6524</b>		
Control Arm-/Trailing Arm Bush	All Models		<b>F8-6673</b>		H=74; d=28; D=55,2
Control Arm-/Trailing Arm Bush	1.9 dCi 80, 1.9 dTi, 2.2 dCi 90, 2.5 D, 2.5 dCi, 2.5 dCi 100, 2.5 dCi 120, 2.8 dTi, 3.0 dCi 140		<b>F8-6674</b>		H=79; d=28; D=55,5
Engine Mounting	2.2 dCi 90, 2.5 dCi 120		<b>F8-6675</b>		
Mounting, leaf spring	1.9 dCi 80, 1.9 dTi, 2.2 dCi 90, 2.5 D, 2.5 dCi 120, 2.8 dTi		<b>F8-6684</b>		
Mounting, axle beam	1.9 dCi 80, 1.9 dTi, 2.2 dCi 90, 2.5 D, 2.5 dCi 120, 2.8 dTi		<b>F8-6686</b>		H=80; d=22; D=47
Control Arm-/Trailing Arm Bush	All Models		<b>F8-6687</b>		
Engine Mounting	2.5 D, 2.8 dTi		<b>F8-6688</b>		
Belt Pulley, crankshaft	2.5 dCi 120	10/2003 →; Number of Ribs: 6	<b>F8-7092</b>		Belt Pulley Ø [mm]=152; Mounting points diam.[mm]=30.6; W=45.5
Belt Pulley, crankshaft	2.5 dCi 120		<b>F8-7653</b>		
Bellow, steering	All Models	with clamps	<b>LM-10032S</b>		d1=9.5; d2=42; L [mm]=165

### MASTER II Van (FD)

07/1998 → 10/2001

Alternator Freewheel Clutch	1.9 dCi 80, 2.2 dCi 90, 2.5 dCi, 2.5 dCi 100, 2.5 dCi 120		<b>F5-1025</b>		
Alternator Freewheel Clutch	3.0 dCi 120, 3.0 dCi 140, 3.0 dCi 160		<b>F5-1035</b>		
Alternator Freewheel Clutch	1.9 dCi 80		<b>F5-1036</b>		
Alternator Freewheel Clutch	2.2 dCi 90, 2.5 dCi, 2.5 dCi 100		<b>F5-1063</b>		
Gear, camshaft	1.9 dTi	Engine Management: Timing Belt; ⚙ 40	<b>F8-6254</b>		d=13; D=120; W=30
Engine Mounting	1.9 dCi 80, 1.9 dTi, 2.2 dCi 90, 2.5 dCi, 2.5 dCi 100, 2.5 dCi 120, 3.0 dCi 140	for OE: 8200027176	<b>F8-6524</b>		
Control Arm-/Trailing Arm Bush	All Models		<b>F8-6673</b>		H=74; d=28; D=55,2
Control Arm-/Trailing Arm Bush	1.9 dCi 80, 1.9 dTi, 2.2 dCi 90, 2.5 D, 2.5 dCi, 2.5 dCi 100, 2.5 dCi 120, 2.8 dTi, 3.0 dCi 120, 3.0 dCi 140, 3.0 dCi 160		<b>F8-6674</b>		H=79; d=28; D=55,5
Engine Mounting	2.2 dCi 90, 2.5 dCi 120		<b>F8-6675</b>		
Mounting, leaf spring	1.9 dCi 80, 1.9 dTi, 2.2 dCi 90, 2.5 D, 2.5 dCi 120, 2.8 dTi		<b>F8-6684</b>		
Mounting, axle beam	1.9 dCi 80, 1.9 dTi, 2.2 dCi 90, 2.5 D, 2.5 dCi 120, 2.8 dTi		<b>F8-6686</b>		H=80; d=22; D=47
Control Arm-/Trailing Arm Bush	All Models		<b>F8-6687</b>		
Engine Mounting	2.5 D, 2.5 dCi 120, 2.8 dTi		<b>F8-6688</b>		
Belt Pulley, crankshaft	2.5 dCi 120		<b>F8-7653</b>		

<b>F5-1025</b>	<b>F5-1035</b>	<b>F5-1036</b>	<b>F5-1063</b>	<b>F8-6254</b>	<b>F8-6524</b>	<b>F8-6673</b>
Ref.Nr.: 23151-00Q0B	Ref.Nr.: 23150-2W200	Ref.Nr.: 23151-00Q0A	Ref.Nr.:	Ref.Nr.: 8200125710	Ref.Nr.: 8200027176	Ref.Nr.: 54570-00QAA
<b>F8-6674</b>	<b>F8-6675</b>	<b>F8-6684</b>	<b>F8-6686</b>	<b>F8-6687</b>	<b>F8-6688</b>	<b>F8-7092</b>
Ref.Nr.: 4500095	Ref.Nr.: 8200022596	Ref.Nr.: 55046-00QAB	Ref.Nr.: 5000392657	Ref.Nr.: 4500091	Ref.Nr.: 9110612	Ref.Nr.: 8200207436
<b>F8-7653</b>	<b>LM-10032S</b>					
Ref.Nr.: 8200267867	Ref.Nr.: 7701470361					

Article Description



Article Nr.

Fitting Position



<b>MASTER II Van (FD)</b>			07/1998 → 10/2001	
Bellow, steering	All Models	with clamps	LM-10032S	d1=9.5; d2=42; L [mm]=165
<b>MASTER II Platform/Chassis (ED/HD/UD)</b>			07/1998 → 10/2001	
Alternator Freewheel Clutch	2.2 dCi 90, 2.5 dCi, 2.5 dCi 100, 2.5 dCi 120		F5-1025	
Alternator Freewheel Clutch	3.0 dCi 120, 3.0 dCi 140, 3.0 dCi 160		F5-1035	
Alternator Freewheel Clutch	2.2 dCi 90, 2.5 dCi, 2.5 dCi 100		F5-1063	
Engine Mounting	2.2 dCi 90, 2.5 dCi, 2.5 dCi 100, 2.5 dCi 120, 3.0 dCi 140	for OE: 8200027176	F8-6524	
Control Arm-/Trailing Arm Bush	All Models		F8-6673	H=74; d=28; D=55,2
Control Arm-/Trailing Arm Bush	2.2 dCi 90, 2.5 D, 2.5 dCi, 2.5 dCi 100, 2.5 dCi 120, 2.8 dTi, 3.0 dCi 120, 3.0 dCi 140, 3.0 dCi 160		F8-6674	H=79; d=28; D=55,5
Engine Mounting	2.2 dCi 90, 2.5 dCi 120		F8-6675	
Mounting, leaf spring	2.2 dCi 90, 2.5 D, 2.5 dCi 120, 2.8 dTi		F8-6684	
Mounting, axle beam	2.2 dCi 90, 2.5 D, 2.5 dCi 120, 2.8 dTi		F8-6686	H=80; d=22; D=47
Control Arm-/Trailing Arm Bush	All Models		F8-6687	
Engine Mounting	2.5 D, 2.8 dTi		F8-6688	
Belt Pulley, crankshaft	2.5 dCi 120		F8-7653	
Bellow, steering	All Models	with clamps	LM-10032S	d1=9.5; d2=42; L [mm]=165
<b>MASTER III Bus (JV)</b>			02/2011 →	
Alternator Freewheel Clutch	2.3 dCi 100 FWD, 2.3 dCi 125 FWD, 2.3 dCi FWD		F5-1129	
Belt Pulley, crankshaft	2.3 dCi 100 FWD, 2.3 dCi 125 FWD, 2.3 dCi 150	Number of Ribs: 6	F8-8039	
<b>MASTER III Box (FV)</b>			02/2010 →	
Alternator Freewheel Clutch	2.3 dCi [RWD], 2.3 dCi FWD		F5-1129	
<b>MASTER III Platform/Chassis (EV, HV, UV)</b>			02/2010 →	
Alternator Freewheel Clutch	2.3 dCi [RWD], 2.3 dCi FWD		F5-1129	
<b>MEGANE I (BA0/1_)</b>			01/1996 → 08/2003	
Dust Cover Kit, shock absorber	1.4 16V, 1.4 e, 1.4 Eco, 1.6 16V, 1.6 e, 1.6 i, 1.8 16V, 1.9 D Eco, 1.9 dCi, 1.9 dT, 1.9 dTi, 1.9 TDI, 2.0 i		AK-735042	
Alternator Freewheel Clutch	1.9 dCi, 1.9 DTi		F5-1014	
Alternator Freewheel Clutch	1.4 16V, 1.6 16V		F5-1029	
Alternator Freewheel Clutch	1.4 16V, 1.4 e, 1.6 16V, 1.6 LPG		F5-1061	
Anti-Friction Bearing	1.4 16V, 1.4 e, 1.4 Eco, 1.6 16V, 1.6 e, 1.6 i, 1.8 16V, 1.9 D Eco, 1.9 dCi, 1.9 dT, 1.9 dTi, 1.9 TDI, 2.0 16V, 2.0 i		F8-3033	H=20; d1=62; d2=64; D=100
Engine Mounting	1.4 e	Type: BA0E	F8-4109	

AK-735042	F5-1014	F5-1025	F5-1029	F5-1035	F5-1061	F5-1063
Ref.Nr.: 7700776743	Ref.Nr.: 8641982	Ref.Nr.: 23151-00Q0B	Ref.Nr.: 7700110616	Ref.Nr.: 23150-2W200	Ref.Nr.: 7700110616	Ref.Nr.:
F5-1129	F8-3033	F8-4109	F8-6524	F8-6673	F8-6674	F8-6675
Ref.Nr.: 23151-JG71B	Ref.Nr.: 7700797666	Ref.Nr.: 7700785949	Ref.Nr.: 8200027176	Ref.Nr.: 54570-00QAA	Ref.Nr.: 4500095	Ref.Nr.: 8200022596
F8-6684	F8-6686	F8-6687	F8-6688	F8-7653		LM-10032S
Ref.Nr.: 55046-00QAB	Ref.Nr.: 5000392657	Ref.Nr.: 4500091	Ref.Nr.: 9110612	Ref.Nr.: 8200267867	Ref.Nr.: 93168039	Ref.Nr.: 7701470361

**Article Description****Article Nr.****Fitting Position**

<b>MEGANE I (BA0/1_)</b>			<b>01/1996 → 08/2003</b>		
Engine Mounting	1.4 Eco , 1.6 i		<b>F8-4109</b>	⊕	
Engine Mounting	1.6 e	Type: BA0F	<b>F8-4109</b>	⊕	
Engine Mounting	1.6 e , 1.6 i		<b>F8-4110</b>		d=12; D=99; T [mm]=119
Stabiliser Mounting	1.6 e , 1.6 i , 1.9 D Eco , 1.9 dT , 2.0 i		<b>F8-5085</b>		d=23
Stabiliser Mounting	1.6 e , 1.6 i , 1.9 D Eco , 1.9 dT , 2.0 i		<b>F8-5086</b>		d=24
Engine Mounting	1.9 dTi	; Type: BA08, BA0N	<b>F8-5472</b>		
Engine Mounting	2.0 i		<b>F8-5472</b>		
Top Strut Mounting	1.4 16V	; Type: BA0W	<b>F8-5473</b>	⊕ ⊕	
Top Strut Mounting	1.4 e	; Type: BA0E	<b>F8-5473</b>	⊕ ⊕	
Top Strut Mounting	1.4 Eco , 1.6 e , 1.6 i , 1.9 D Eco , 1.9 dT , 2.0 i		<b>F8-5473</b>	⊕ ⊕	
Top Strut Mounting	1.6 16V	; Type: BA04	<b>F8-5473</b>	⊕ ⊕	
Top Strut Mounting	1.9 dTi	06/1997 →; ; Type: BA0N	<b>F8-5473</b>	⊕ ⊕	
Engine Mounting	1.4 16V	K4J 750	<b>F8-5476</b>		
Engine Mounting	1.6 16V	K4M 700;	<b>F8-5476</b>		
Engine Mounting	1.4 e	Type: BA0E	<b>F8-5482</b>	⊕	
Engine Mounting	1.4 Eco		<b>F8-5482</b>	⊕	
Engine Mounting	1.6 e , 1.6 i		<b>F8-5482</b>	⊕	
Mounting, automatic transmission	1.4 16V	Type: BA0W	<b>F8-5485</b>		
Mounting, automatic transmission	1.6 16V	Type: BA04	<b>F8-5485</b>		
Mounting, automatic transmission	1.6 e	07/1986 →;	<b>F8-5485</b>	⊕	
Mounting, automatic transmission	1.9 D Eco	09/1989 →	<b>F8-5485</b>	⊕	
Mounting, automatic transmission	1.9 dT	09/1989 →;  4-speed	<b>F8-5485</b>	⊕	
Mounting, automatic transmission	1.9 dTi	03/1999 →; Type: BA0N	<b>F8-5485</b>		
Mounting, automatic transmission	2.0 i	07/1986 →;  4-speed	<b>F8-5485</b>	⊕	
Engine Mounting	1.9 D Eco , 1.9 dCi , 1.9 dT , 1.9 dTi , 1.9 TDI		<b>F8-5490</b>		
Belt Pulley, crankshaft	1.9 D Eco , 1.9 dT , 1.9 dTi , 1.9 TDI		<b>F8-5645</b>		
Belt Pulley, crankshaft	1.9 DCi	F9Q 732	<b>F8-5656</b>		
Belt Pulley, crankshaft	1.9 dCi , 1.9 dTi		<b>F8-5656</b>		
Belt Pulley, crankshaft	1.9 dTi	F9Q 731	<b>F8-5656</b>		
Repair Set, axle beam	1.4 e , 1.4 Eco , 1.6 e , 1.6 i , 1.9 D Eco		<b>F8-6097</b>	⊕ ⊕	
Gear, camshaft	1.9 dTi	10/2000 →;  F9Q 731, F9Q 736; Engine Management: Timing Belt;  40	<b>F8-6254</b>		d=13; D=120; W=30

<b>F8-4109</b>	<b>F8-4110</b>	<b>F8-5085</b>	<b>F8-5086</b>	<b>F8-5472</b>	<b>F8-5473</b>	<b>F8-5476</b>
Ref.Nr.: 7700785949	Ref.Nr.: 7700805733	Ref.Nr.: 7700785788	Ref.Nr.: 7700785929	Ref.Nr.: 7700832262	Ref.Nr.: 7700780875	Ref.Nr.: 7700832264
<b>F8-5482</b>	<b>F8-5485</b>	<b>F8-5490</b>	<b>F8-5645</b>	<b>F8-5656</b>	<b>F8-6097</b>	<b>F8-6254</b>
Ref.Nr.: 7700794601	Ref.Nr.: 7700788318	Ref.Nr.: 7700413614	Ref.Nr.: 7700724249	Ref.Nr.: 7700115309	Ref.Nr.: 7701464321	Ref.Nr.: 8200125710

Article Description



Article Nr.

Fitting Position



**MEGANE I (BA0/1\_)**

01/1996 → 08/2003

Gear, camshaft	1.9 dTi	Engine Management: Timing Belt; 40	<b>F8-6254</b>		d=13; D=120; W=30
Top Strut Mounting	1.4 16V	☺; Type: BA0W	<b>F8-6379</b>		
Top Strut Mounting	1.4 e , 1.4 Eco , 1.6 i , 1.9 D Eco , 1.9 dTi , 1.9 TDI, 2.0 16V , 2.0 i	☺	<b>F8-6379</b>		
Top Strut Mounting	1.6 16V	☺; Type: BA00, BA04, BA0B, BA11, BA1J, BA1K	<b>F8-6379</b>		
Top Strut Mounting	1.6 e	☺; Type: BA0F, BA0S, BA1C	<b>F8-6379</b>		
Top Strut Mounting	1.8 16V	☺; Type: BA12, BA1A, BA1M, BA1R	<b>F8-6379</b>		
Top Strut Mounting	1.9 dCi	☺; Type: BA01, BA05, BA1F	<b>F8-6379</b>		
Top Strut Mounting	1.9 dT	☺; Type: BA09, BA0K, BA0R, BA0Y, SA0K, SA0Y	<b>F8-6379</b>		
Top Strut Mounting	2.0 i	☺; Type: BA07, BA0G	<b>F8-6379</b>		
Engine Mounting	1.8 16V	F4P 722; Aluminium	<b>F8-6482</b>		
Engine Mounting	1.9 D Eco	F8Q 620; Aluminium	<b>F8-6482</b>		
Engine Mounting	1.9 dCi	Aluminium;	<b>F8-6482</b>		
Engine Mounting	1.9 dTi	Aluminium	<b>F8-6482</b>		
Engine Mounting	1.9 dTi	F9Q 734, F9Q 736; Aluminium	<b>F8-6482</b>		
Engine Mounting	1.9 D Eco	Type: BA0U, SA0U	<b>F8-6483</b>	⊕	
Engine Mounting	1.9 dCi , 2.0 16V , 2.0 i		<b>F8-6483</b>	⊕	
Engine Mounting	1.9 dT	Type: BA0Y	<b>F8-6483</b>	⊕	
Engine Mounting	1.9 dTi	03/1999 →; Type: BA0N	<b>F8-6483</b>	⊕	
Engine Mounting	1.4 16V , 1.6 16V	11/1999 →	<b>F8-6598</b>		
Stabiliser Mounting	1.9 D Eco , 1.9 dT , 1.9 dTi , 1.9 TDI, 2.0 16V , 2.0 i		<b>F8-6786</b>		
Stabiliser Mounting	1.4 16V , 1.4 e , 1.4 Eco , 1.6 16V , 1.6 e , 1.6 i , 1.8 16V , 1.9 D Eco , 1.9 dCi , 1.9 dT , 1.9 dTi , 1.9 TDI, 2.0 16V , 2.0 i		<b>F8-6796</b>		d=18
Mounting, axle bracket	1.4 e	Type: BA0E	<b>F8-7045</b>		
Mounting, axle bracket	1.4 Eco , 1.6 i , 2.0 i		<b>F8-7045</b>		
Mounting, axle bracket	1.6 e	Type: BA0F	<b>F8-7045</b>		
Mounting, axle bracket	1.9 D Eco	Type: BA0U, SA0U	<b>F8-7045</b>		
Mounting, axle bracket	1.9 dT	Type: BA09, BA0Y	<b>F8-7045</b>		
Mounting, axle bracket	1.9 dTi	Type: BA09, BA0K	<b>F8-7045</b>		
Bearing, drive shaft	1.4 16V , 1.4 e , 1.6 16V , 1.6 e , 1.6 i , 1.9 D Eco , 1.9 dT , 1.9 TDI, 2.0 i		<b>F8-7173</b>		d=25.8
Belt Pulley, crankshaft	2.0 i		<b>F8-7654</b>		
Stabiliser Mounting	1.4 16V , 1.4 e , 1.6 16V , 2.0 i		<b>F8-7905</b>	⊕ ⊕	d=24,5
Stabiliser Mounting	1.6 e , 1.6 i	Engine →980513	<b>F8-7905</b>	⊕ ⊕	d=24,5

<b>F8-6254</b>	<b>F8-6379</b>	<b>F8-6482</b>	<b>F8-6483</b>	<b>F8-6598</b>	<b>F8-6786</b>	<b>F8-6796</b>
Ref.Nr.: 8200125710	Ref.Nr.: 7700797654	Ref.Nr.: 82 00 148 388	Ref.Nr.: 77 00 832 256	Ref.Nr.: 77 00 437 854	Ref.Nr.: 7700847383	Ref.Nr.: 7700784170
<b>F8-7045</b>	<b>F8-7173</b>	<b>F8-7654</b>	<b>F8-7905</b>			
Ref.Nr.: 7700779772	Ref.Nr.: 7664079	Ref.Nr.: 7700109260	Ref.Nr.: 82 00 150 759			



**Article Description****Article Nr.****Fitting Position**

<b>MEGANE I (BA0/1_)</b>		<b>01/1996 → 08/2003</b>			
Stabiliser Mounting	1.9 D Eco	Engine980513→	<b>F8-7905</b>		d=24,5
Stabiliser Mounting	1.4 16V, 1.4 e, 1.4 Eco, 1.6 16V, 1.6 e, 1.6 i, 1.8 16V, 1.9 D Eco, 1.9 dCi, 1.9 dT, 1.9 dTi, 1.9 TDI, 2.0 16V, 2.0 i		<b>F8-7942</b>		
Engine Mounting	1.4 16V, 1.4 e, 1.6 16V, 1.8 16V, 1.9 D Eco, 1.9 dT, 1.9 dTi, 1.9 TDI		<b>F8-8146</b>		
Control Arm-/Trailing Arm Bush	1.4 16V, 1.4 e, 1.4 Eco, 1.6 16V, 1.6 e, 1.6 i, 2.0 i		<b>G9-569</b>		H=46; d=12; D1=45; D2=48
Control Arm-/Trailing Arm Bush	1.9 D Eco, 1.9 dT, 1.9 dTi, 1.9 TDI, 2.0 16V		<b>G9-653</b>		H1=35; H2=46; d=12; D=45
Bellow, steering	1.4 16V, 1.4 e, 1.4 Eco, 1.6 16V, 1.6 e, 1.6 i, 1.8 16V, 1.9 D Eco, 1.9 dCi, 1.9 dT, 1.9 dTi, 1.9 TDI, 2.0 16V, 2.0 i	for steering gear ID: SMI; with clamps;	<b>LM-10000S</b>		d1=9; d2=39; L [mm]=168
Bellow, steering	1.4 16V, 1.4 e, 1.4 Eco, 1.6 16V, 1.6 e, 1.6 i, 1.8 16V, 1.9 dCi, 1.9 dTi, 1.9 TDI, 2.0 16V, 2.0 i	with clamps;	<b>LM-10001S</b>		d1=10; d2=30; L [mm]=158
Bellow, steering	1.9 D Eco	with clamps; Type: BA0A, BA0U;	<b>LM-10001S</b>		d1=10; d2=30; L [mm]=158
Bellow, steering	1.9 dT	with clamps; Type: BA0K, BA0Y;	<b>LM-10001S</b>		d1=10; d2=30; L [mm]=158
Bellow, steering	1.9 D Eco	Manufacturer Restriction: TRW; with clamps; Type: SA0U;	<b>LM-10009S</b>		d1=12; d2=40; L [mm]=170
Bellow, steering	1.9 dT	Manufacturer Restriction: TRW; with clamps; Type: SA0Y;	<b>LM-10009S</b>		d1=12; d2=40; L [mm]=170
Bellow, steering	1.4 16V, 1.4 e, 1.4 Eco, 1.6 16V, 1.6 e, 1.6 i, 1.8 16V, 1.9 dCi, 1.9 dTi, 1.9 TDI, 2.0 16V, 2.0 i	with clamps;	<b>LM-10042S</b>		d1=10; d2=27.5; L [mm]=155
Bellow, steering	1.9 D Eco	with clamps; Type: BA0A, BA0U;	<b>LM-10042S</b>		d1=10; d2=27.5; L [mm]=155
Bellow, steering	1.9 dT	with clamps; Type: BA0K, BA0Y;	<b>LM-10042S</b>		d1=10; d2=27.5; L [mm]=155
Bellow Set, drive shaft	1.4 16V, 1.4 e, 1.4 Eco, 1.6 16V, 1.6 e, 1.6 i, 1.9 D Eco, 2.0 i		<b>M-850850</b>		H=120; d1=28; d2=75.5
Bellow Set, drive shaft	1.4 e, 1.4 Eco, 1.6 e, 1.6 i, 1.9 D Eco		<b>M-870870</b>		
Bellow Set, drive shaft	1.4 16V, 1.4 e, 1.4 Eco, 1.6 16V, 1.6 e, 1.6 i, 1.9 D Eco, 2.0 i	ABS;	<b>MK-850850</b>		
<b>MEGANE I Cabriolet (EA0/1_)</b>		<b>10/1996 → 08/2003</b>			
Dust Cover Kit, shock absorber	1.4 16V, 1.6 16V, 1.6 e, 2.0, 2.0 i		<b>AK-735042</b>		
Alternator Freewheel Clutch	1.4 16V, 1.6 16V		<b>F5-1029</b>		
Alternator Freewheel Clutch	1.4 16V, 1.6 16V		<b>F5-1061</b>		
Anti-Friction Bearing	1.4 16V, 1.6 16V, 1.6 e, 2.0, 2.0 16V, 2.0 16V IDE, 2.0 i		<b>F8-3033</b>		H=20; d1=62; d2=64; D=100
Engine Mounting	1.6 e		<b>F8-4109</b>		
Engine Mounting	2.0, 2.0 i		<b>F8-5472</b>		
Engine Mounting	2.0 16V		<b>F8-5472</b>		
Top Strut Mounting	1.4 16V	; Type: EA0W	<b>F8-5473</b>		
Top Strut Mounting	1.6 16V	; Type: EA04	<b>F8-5473</b>		

<b>AK-735042</b>	<b>F5-1029</b>	<b>F5-1061</b>	<b>F8-3033</b>	<b>F8-4109</b>	<b>F8-5472</b>	<b>F8-5473</b>
Ref.Nr.: 7700776743	Ref.Nr.: 7700110616	Ref.Nr.: 7700110616	Ref.Nr.: 7700797666	Ref.Nr.: 7700785949	Ref.Nr.: 7700832262	Ref.Nr.: 7700780875
<b>F8-7905</b>	<b>F8-7942</b>	<b>F8-8146</b>	<b>G9-569</b>	<b>G9-653</b>	<b>LM-10000S</b>	<b>LM-10001S</b>
Ref.Nr.: 82 00 150 759	Ref.Nr.: 7700784171	Ref.Nr.: 7700425757	Ref.Nr.: 7700789478	Ref.Nr.: 7700789477	Ref.Nr.: 6000025546	Ref.Nr.: 7700678649
<b>LM-10009S</b>	<b>LM-10042S</b>	<b>M-850850</b>	<b>M-870870</b>	<b>MK-850850</b>		
Ref.Nr.: 7701469486	Ref.Nr.: 7701469497	Ref.Nr.: 329373	Ref.Nr.: 7701450617	Ref.Nr.: 329373		

Article Description



Article Nr.

Fitting Position



MEGANE I Cabriolet (EA0/1_)			10/1996 → 08/2003	
Top Strut Mounting	1.6 e , 2.0		F8-5473	
Engine Mounting	1.4 16V , 1.6 16V		F8-5476	
Engine Mounting	1.6 e		F8-5482	
Mounting, automatic transmission	1.4 16V	Type: EA0W	F8-5485	
Mounting, automatic transmission	1.6 16V	Type: EA04	F8-5485	
Mounting, automatic transmission	2.0 , 2.0 16V		F8-5485	
Anti-Friction Bearing	2.0 16V		F8-6335	
Top Strut Mounting	1.4 16V , 1.6 e , 2.0 , 2.0 16V, 2.0 i		F8-6379	
Top Strut Mounting	1.6 16V	; Type: EA04, EA11	F8-6379	
Engine Mounting	2.0 16V		F8-6420	
Engine Mounting	2.0 , 2.0 16V		F8-6483	
Engine Mounting	1.4 16V , 1.6 16V	11/1999 →	F8-6598	
Mounting, axle beam	2.0 16V		F8-6679	d=12; D=70
Stabiliser Mounting	2.0 , 2.0 16V , 2.0 16V IDE , 2.0 i		F8-6786	
Stabiliser Mounting	All Models		F8-6796	d=18
Mounting, axle bracket	1.6 e , 2.0 , 2.0 16V		F8-7045	
Belt Pulley, crankshaft	1.4 16V , 1.6 16V	Number of Ribs: 6	F8-7094	Belt Pulley Ø [mm]=134; Mounting points diam.[mm]=26; W=33
Bearing, drive shaft	1.4 16V , 1.6 16V , 1.6 e , 2.0		F8-7173	d=25.8
Belt Pulley, crankshaft	2.0 , 2.0 i		F8-7654	
Stabiliser Mounting	1.4 16V , 2.0		F8-7905	d=24,5
Stabiliser Mounting	1.6 16V	Engine: K4M 700, K4M 701	F8-7905	d=24,5
Stabiliser Mounting	1.6 e	Engine980709→	F8-7905	d=24,5
Stabiliser Mounting	2.0 i	Prod. date →9903	F8-7905	d=24,5
Stabiliser Mounting	All Models		F8-7942	
Engine Mounting	1.4 16V , 1.6 16V , 2.0 16V , 2.0 16V IDE		F8-8146	
Control Arm-/Trailing Arm Bush	1.4 16V , 1.6 16V , 1.6 e , 2.0 , 2.0 i		G9-569	H=46; d=12; D1=45; D2=48
Control Arm-/Trailing Arm Bush	2.0 16V , 2.0 16V IDE		G9-653	H1=35; H2=46; d=12; D=45
Bellow, steering	All Models	for steering gear ID: SMI; with clamps;	LM-10000S	d1=9; d2=39; L [mm]=168
Bellow, steering	1.4 16V , 1.6 16V , 1.6 e , 2.0 , 2.0 16V , 2.0 16V IDE , 2.0 i	; Manufacturer Restriction: TRW; with clamps;	LM-10009S	d1=12; d2=40; L [mm]=170
Bellow, steering	1.4 16V , 1.6 16V , 1.6 e , 2.0 , 2.0 16V , 2.0 16V IDE , 2.0 i	; with clamps	LM-10009S	d1=12; d2=40; L [mm]=170

<b>F8-5473</b>	<b>F8-5476</b>	<b>F8-5482</b>	<b>F8-5485</b>	<b>F8-6335</b>	<b>F8-6379</b>	<b>F8-6420</b>
Ref.Nr.: 7700780875	Ref.Nr.: 7700832264	Ref.Nr.: 7700794601	Ref.Nr.: 7700788318	Ref.Nr.: 7701208891	Ref.Nr.: 7700797654	Ref.Nr.: 8200338381
<b>F8-6483</b>	<b>F8-6598</b>	<b>F8-6679</b>	<b>F8-6786</b>	<b>F8-6796</b>	<b>F8-7045</b>	<b>F8-7094</b>
Ref.Nr.: 77 00 832 256	Ref.Nr.: 77 00 437 854	Ref.Nr.: 8200038243	Ref.Nr.: 7700847383	Ref.Nr.: 7700784170	Ref.Nr.: 7700797772	Ref.Nr.: 8200392683
<b>F8-7173</b>	<b>F8-7654</b>	<b>F8-7905</b>	<b>F8-7942</b>	<b>F8-8146</b>	<b>G9-569</b>	<b>G9-653</b>
Ref.Nr.: 7664079	Ref.Nr.: 7700109260	Ref.Nr.: 82 00 150 759	Ref.Nr.: 7700784171	Ref.Nr.: 7700425757	Ref.Nr.: 7700789478	Ref.Nr.: 7700789477

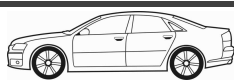
**Article Description****Article Nr.****Fitting Position**

<b>MEGANE I Cabriolet (EA0/1_)</b>		<b>10/1996 → 08/2003</b>	
Bellow, steering	1.4 16V, 1.6 16V, 1.6 e, 2.0, 2.0 16V, 2.0 16V IDE, 2.0 i	; Manufacturer Restriction: TRW; with clamps;	<b>LM-10028S</b> ⊕
Bellow, steering	1.4 16V, 1.6 16V, 1.6 e, 2.0, 2.0 16V, 2.0 16V IDE, 2.0 i	; with clamps	<b>LM-10028S</b> ⊕
Bellow Set, drive shaft	1.4 16V, 1.6 16V, 1.6 e, 2.0, 2.0 i		<b>M-850850</b> ⊕ ⊕
Bellow Set, drive shaft	1.4 16V, 1.6 16V, 1.6 e, 2.0, 2.0 i	<b>ABS</b> ;	<b>MK-850850</b> ⊕ ⊕ ⊕
<b>MEGANE I Classic (LA0/1_)</b>		<b>09/1996 → 08/2003</b>	
Dust Cover Kit, shock absorber	1.4, 1.4 16V, 1.6 16V, 1.6 e, 1.6 i, 1.8 16V, 1.9 D, 1.9 dCi, 1.9 dT, 1.9 dTi, 1.9 TDI, 2.0 i		<b>AK-735042</b> ⊕ ⊕ ⊕
Alternator Freewheel Clutch	1.9 dCi, 1.9 dTi		<b>F5-1014</b>
Alternator Freewheel Clutch	1.4 16V		<b>F5-1029</b>
Alternator Freewheel Clutch	1.4, 1.4 16V, 1.6 16V		<b>F5-1061</b>
Anti-Friction Bearing	1.4, 1.4 16V, 1.6 16V, 1.6 e, 1.6 i, 1.9 D, 1.9 dT, 1.9 dTi, 1.9 TDI, 2.0 i, 2.0 RT		<b>F8-3033</b> ⊕ ⊕ ⊕
Engine Mounting	1.4	Type: LA0E	<b>F8-4109</b> ⊕
Engine Mounting	1.6 e	Type: LA0F	<b>F8-4109</b> ⊕
Engine Mounting	1.6 i		<b>F8-4109</b> ⊕
Engine Mounting	1.9 dTi	; Type: LA05, LA0N	<b>F8-5472</b>
Engine Mounting	2.0 i		<b>F8-5472</b>
Top Strut Mounting	1.4, 1.6 i, 1.9 D, 1.9 TDI		<b>F8-5473</b> ⊕ ⊕ ⊕
Top Strut Mounting	1.4 16V	; Type: LA0W	<b>F8-5473</b> ⊕ ⊕ ⊕
Top Strut Mounting	1.6 16V	; Type: LA04	<b>F8-5473</b> ⊕ ⊕ ⊕
Top Strut Mounting	1.6 e	; Type: LA0F	<b>F8-5473</b> ⊕ ⊕ ⊕
Top Strut Mounting	1.9 dT	; Type: LA0K	<b>F8-5473</b> ⊕ ⊕ ⊕
Top Strut Mounting	1.9 dTi	06/1997 →; ; Type: LA0N	<b>F8-5473</b> ⊕ ⊕ ⊕
Top Strut Mounting	2.0 i	; Type: LA0G	<b>F8-5473</b> ⊕ ⊕ ⊕
Engine Mounting	1.4 16V	; K4J 750	<b>F8-5476</b>
Engine Mounting	1.6 16V	; K4M 701;	<b>F8-5476</b>
Engine Mounting	1.9 D, 1.9 TDI		<b>F8-5476</b>
Engine Mounting	1.4	Type: LA0E	<b>F8-5482</b> ⊕
Engine Mounting	1.6 e	; Type: LA0F	<b>F8-5482</b> ⊕
Engine Mounting	1.6 i		<b>F8-5482</b> ⊕
Mounting, automatic transmission	1.4	03/1999 →; Type: LA0V	<b>F8-5485</b>
Mounting, automatic transmission	1.6 16V	Type: LA04	<b>F8-5485</b>
Mounting, automatic transmission	1.6 e	; Type: LA0F	<b>F8-5485</b>

<b>AK-735042</b>	<b>F5-1014</b>	<b>F5-1029</b>	<b>F5-1061</b>	<b>F8-3033</b>	<b>F8-4109</b>	<b>F8-5472</b>
Ref.Nr.: 7700776743	Ref.Nr.: 8641982	Ref.Nr.: 7700110616	Ref.Nr.: 7700110616	Ref.Nr.: 7700797666	Ref.Nr.: 7700785949	Ref.Nr.: 7700832262
<b>F8-5473</b>	<b>F8-5476</b>	<b>F8-5482</b>	<b>F8-5485</b>	<b>LM-10028S</b>	<b>M-850850</b>	<b>MK-850850</b>
Ref.Nr.: 7700780875	Ref.Nr.: 7700832264	Ref.Nr.: 7700794601	Ref.Nr.: 7700788318	Ref.Nr.: 7701469487	Ref.Nr.: 329373	Ref.Nr.: 329373

Article Description



Article Nr.

Fitting Position



MEGANE I Classic (LA0/1_)			09/1996 → 08/2003		
Mounting, automatic transmission	1.9 D , 1.9 TDI		F8-5485		
Mounting, automatic transmission	1.9 dTi	03/1999 →; Type: LA0N	F8-5485		
Mounting, automatic transmission	2.0 i	Type: LA0G	F8-5485		
Engine Mounting	1.9 D , 1.9 dCi , 1.9 dT , 1.9 dTi , 1.9 TDI		F8-5490		
Belt Pulley, crankshaft	1.9 D , 1.9 dT , 1.9 dTi , 1.9 TDI		F8-5645		
Belt Pulley, crankshaft	1.9 dCi	F9Q 733	F8-5656		
Belt Pulley, crankshaft	1.9 dTi		F8-5656		
Belt Pulley, crankshaft	1.9 dTi	F9Q 731	F8-5656		
Repair Set, axle beam	1.4 , 1.4 16V , 1.6 16V , 1.6 e , 1.9 D , 1.9 dTi , 2.0 i , 2.0 RT		F8-6097		
Gear, camshaft	1.9 dTi	10/2000 →;  F9Q 731, F9Q 736; Engine Management: Timing Belt;  40	F8-6254		d=13; D=120; W=30
Gear, camshaft	1.9 dTi	Engine Management: Timing Belt;  40	F8-6254		d=13; D=120; W=30
Top Strut Mounting	1.4 , 1.6 e , 1.6 i , 1.9 dT , 1.9 dTi , 1.9 TDI , 2.0 i		F8-6379		
Top Strut Mounting	1.4 16V	; Type: LA0D, LA0W, LA10	F8-6379		
Top Strut Mounting	1.6 16V	; Type: LA04, LA0B, LA11, LA1C	F8-6379		
Top Strut Mounting	1.8 16V	; Type: LA12, LA1A, LA1M	F8-6379		
Top Strut Mounting	1.9 D	; Type: LA0A, LA0U	F8-6379		
Top Strut Mounting	1.9 dCi	; Type: LA05, LA1F	F8-6379		
Engine Mounting	1.8 16V	F4P 722; Aluminium	F8-6482		
Engine Mounting	1.9 dCi , 1.9 dTi	Aluminium	F8-6482		
Engine Mounting	1.9 D , 1.9 dCi		F8-6483		
Engine Mounting	1.9 dT	Type: LA0K	F8-6483		
Engine Mounting	1.9 dTi	03/1999 →; Type: LA0N	F8-6483		
Engine Mounting	2.0 i	Type: LA0G	F8-6483		
Stabiliser Mounting	1.9 D , 1.9 dT , 1.9 dTi , 1.9 TDI , 2.0 i		F8-6786		
Stabiliser Mounting	1.4 , 1.4 16V , 1.6 16V , 1.6 e , 1.6 i , 1.8 16V , 1.9 D , 1.9 dCi , 1.9 dT , 1.9 dTi , 1.9 TDI , 2.0 i		F8-6796		d=18
Mounting, axle bracket	1.4	Type: LA0E	F8-7045		
Mounting, axle bracket	1.6 e	Type: LA0F	F8-7045		
Mounting, axle bracket	1.6 i , 1.9 D , 1.9 dTi , 1.9 TDI		F8-7045		
Mounting, axle bracket	1.9 dT	Type: LA0K	F8-7045		
Mounting, axle bracket	2.0 i	Type: LA0G	F8-7045		

<b>F8-5485</b>	<b>F8-5490</b>	<b>F8-5645</b>	<b>F8-5656</b>	<b>F8-6097</b>	<b>F8-6254</b>	<b>F8-6379</b>
Ref.Nr.: 7700788318	Ref.Nr.: 7700413614	Ref.Nr.: 7700724249	Ref.Nr.: 7700115309	Ref.Nr.: 7701464321	Ref.Nr.: 8200125710	Ref.Nr.: 7700797654
<b>F8-6482</b>	<b>F8-6483</b>	<b>F8-6786</b>	<b>F8-6796</b>	<b>F8-7045</b>	<b>F8-7094</b>	
Ref.Nr.: 82 00 148 388	Ref.Nr.: 77 00 832 256	Ref.Nr.: 7700847383	Ref.Nr.: 7700784170	Ref.Nr.: 7700779772	Ref.Nr.: 8200392683	

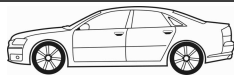
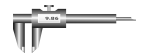
**Article Description****Article Nr.****Fitting Position**

<b>MEGANE I Classic (LA0/1_)</b>			<b>09/1996 → 08/2003</b>		
Belt Pulley, crankshaft	1.4 16V, 1.6 16V	Number of Ribs: 6	<b>F8-7094</b>		Belt Pulley Ø [mm]=134; Mounting points diam.[mm]=26; W=33
Bearing, drive shaft	1.4, 1.4 16V, 1.6 16V, 1.6 e, 1.6 i, 1.9 D, 1.9 dT, 1.9 TDI		<b>F8-7173</b>		d=25.8
Belt Pulley, crankshaft	2.0 i		<b>F8-7654</b>		
Stabiliser Mounting	1.4, 1.4 16V		<b>F8-7905</b>		d=24,5
Stabiliser Mounting	1.6 16V	Engine: K4M 700, K4M 701	<b>F8-7905</b>		d=24,5
Stabiliser Mounting	1.6 e, 1.6 i, 1.9 D, 1.9 dTi	Engine 980709→	<b>F8-7905</b>		d=24,5
Stabiliser Mounting	2.0 i	Prod. date →9903	<b>F8-7905</b>		d=24,5
Stabiliser Mounting	1.4, 1.4 16V, 1.6 16V, 1.6 e, 1.6 i, 1.8 16V, 1.9 D, 1.9 dCi, 1.9 dT, 1.9 dTi, 1.9 TDI, 2.0 i		<b>F8-7942</b>		
Engine Mounting	1.4, 1.4 16V, 1.6 16V, 1.8 16V, 1.9 D, 1.9 dT, 1.9 dTi, 1.9 TDI		<b>F8-8146</b>		
Control Arm-/Trailing Arm Bush	1.4, 1.4 16V, 1.6 16V, 1.6 e, 1.6 i, 2.0 i		<b>G9-569</b>		H=46; d=12; D1=45; D2=48
Control Arm-/Trailing Arm Bush	1.9 D, 1.9 dT, 1.9 dTi, 1.9 TDI		<b>G9-653</b>		H1=35; H2=46; d=12; D=45
Bellow, steering	1.4, 1.4 16V, 1.6 16V, 1.6 e, 1.6 i, 1.8 16V, 1.9 D, 1.9 dCi, 1.9 dT, 1.9 dTi, 1.9 TDI, 2.0 i	for steering gear ID: SMI; with clamps;	<b>LM-10000S</b>		d1=9; d2=39; L [mm]=168
Bellow Set, drive shaft	1.4, 1.4 16V, 1.6 16V, 1.6 e, 1.6 i, 1.9 D, 2.0 i		<b>M-850850</b>		H=120; d1=28; d2=75.5
Bellow Set, drive shaft	1.4, 1.4 16V, 1.6 16V, 1.6 e, 1.6 i, 1.9 D, 2.0 i	ABS;	<b>MK-850850</b>		
<b>MEGANE I Coach (DA0/1_)</b>			<b>03/1996 → 08/2003</b>		
Dust Cover Kit, shock absorber	1.4 16V, 1.6 16V, 1.6 e, 1.9 dCi, 1.9 dTi, 2.0 i		<b>AK-735042</b>		
Alternator Freewheel Clutch	1.9 dCi, 1.9 dTi		<b>F5-1014</b>		
Alternator Freewheel Clutch	1.4 16V		<b>F5-1029</b>		
Alternator Freewheel Clutch	1.4 16V, 1.6 16V		<b>F5-1061</b>		
Anti-Friction Bearing	All Models		<b>F8-3033</b>		H=20; d1=62; d2=64; D=100
Engine Mounting	1.6 e		<b>F8-4109</b>		
Engine Mounting	1.6 e		<b>F8-4110</b>		d=12; D=99; T [mm]=119
Stabiliser Mounting	1.6 e	11/1996 →	<b>F8-5085</b>		d=23
Stabiliser Mounting	1.6 e		<b>F8-5086</b>		d=24
Engine Mounting	1.9 dTi, 2.0 i		<b>F8-5472</b>		
Engine Mounting	2.0 16V		<b>F8-5472</b>		
Top Strut Mounting	1.4 16V	; Type: DA0W	<b>F8-5473</b>		
Top Strut Mounting	1.6 16V	; Type: DA04	<b>F8-5473</b>		
Top Strut Mounting	1.6 e, 1.9 dTi, 2.0 i		<b>F8-5473</b>		
Engine Mounting	1.4 16V	; K4J 750	<b>F8-5476</b>		

<b>AK-735042</b>	<b>F5-1014</b>	<b>F5-1029</b>	<b>F5-1061</b>	<b>F8-3033</b>	<b>F8-4109</b>	<b>F8-4110</b>
Ref.Nr.: 7700776743	Ref.Nr.: 8641982	Ref.Nr.: 7700110616	Ref.Nr.: 7700110616	Ref.Nr.: 7700797666	Ref.Nr.: 7700785949	Ref.Nr.: 7700805733
<b>F8-5085</b>	<b>F8-5086</b>	<b>F8-5472</b>	<b>F8-5473</b>	<b>F8-5476</b>	<b>F8-7094</b>	<b>F8-7173</b>
Ref.Nr.: 7700785788	Ref.Nr.: 7700785929	Ref.Nr.: 7700832262	Ref.Nr.: 7700780875	Ref.Nr.: 7700832264	Ref.Nr.: 8200392683	Ref.Nr.: 7664079
<b>F8-7654</b>	<b>F8-7905</b>	<b>F8-7942</b>	<b>F8-8146</b>	<b>G9-569</b>	<b>G9-653</b>	<b>LM-10000S</b>
Ref.Nr.: 7700109260	Ref.Nr.: 82 00 150 759	Ref.Nr.: 7700784171	Ref.Nr.: 7700425757	Ref.Nr.: 7700789478	Ref.Nr.: 7700789477	Ref.Nr.: 6000025546

Article Description



Article Nr.

Fitting Position



MEGANE I Coach (DA0/1_)			03/1996 → 08/2003	
Engine Mounting	1.6 16V		F8-5476	
Engine Mounting	1.6 e	01/1997 →;	F8-5482	
Mounting, automatic transmission	1.4 16V	Type: DA0W	F8-5485	
Mounting, automatic transmission	1.6 16V	Type: DA04	F8-5485	
Mounting, automatic transmission	1.6 e	09/1989 →;	F8-5485	
Mounting, automatic transmission	1.9 dTi	06/1997 →	F8-5485	
Mounting, automatic transmission	2.0 16V, 2.0 i		F8-5485	
Mounting, automatic transmission	2.0 16V IDE	Type: DA03	F8-5485	
Belt Pulley, crankshaft	1.9 dCi, 1.9 dTi		F8-5656	
Gear, camshaft	1.9 dTi	10/2000 →;  F9Q 731, F9Q 736; Engine Management: Timing Belt;  40	F8-6254	d=13; D=120; W=30
Top Strut Mounting	1.4 16V, 1.6 e, 1.9 dCi, 1.9 dTi, 2.0 i		F8-6379	
Top Strut Mounting	1.6 16V	; Type: DA04, DA0B, DA11	F8-6379	
Engine Mounting	1.9 dCi, 1.9 dTi	Aluminium;	F8-6482	
Engine Mounting	2.0 i	F3R750; Aluminium	F8-6482	
Engine Mounting	1.9 dCi, 2.0 16V, 2.0 i		F8-6483	
Engine Mounting	1.9 dTi	06/1997 →	F8-6483	
Engine Mounting	1.4 16V, 1.6 16V	11/1999 →	F8-6598	
Stabiliser Mounting	1.9 dTi, 2.0 16V, 2.0 16V IDE, 2.0 i		F8-6786	
Stabiliser Mounting	All Models		F8-6796	d=18
Mounting, axle bracket	1.6 e, 1.9 dTi, 2.0 i		F8-7045	
Belt Pulley, crankshaft	1.4 16V, 1.6 16V	Number of Ribs: 6	F8-7094	Belt Pulley Ø [mm]=134; Mounting points diam.[mm]=26; W=33
Bearing, drive shaft	1.4 16V, 1.6 16V, 1.6 e, 2.0 i		F8-7173	d=25.8
Belt Pulley, crankshaft	2.0 i		F8-7654	
Stabiliser Mounting	1.4 16V, 2.0 i		F8-7905	d=24,5
Stabiliser Mounting	1.6 16V	Engine: K4M 700, K4M 701	F8-7905	d=24,5
Stabiliser Mounting	1.6 e, 1.9 dTi	Engine980709→	F8-7905	d=24,5
Stabiliser Mounting	2.0 i	Prod. date →9903	F8-7905	d=24,5
Stabiliser Mounting	All Models		F8-7942	
Engine Mounting	1.4 16V, 1.6 16V, 2.0 16V, 2.0 16V IDE		F8-8146	

<b>F8-5476</b>	<b>F8-5482</b>	<b>F8-5485</b>	<b>F8-5656</b>	<b>F8-6254</b>	<b>F8-6379</b>	<b>F8-6482</b>
Ref.Nr.: 7700832264	Ref.Nr.: 7700794601	Ref.Nr.: 7700788318	Ref.Nr.: 7700115309	Ref.Nr.: 8200125710	Ref.Nr.: 7700797654	Ref.Nr.: 82 00 148 388
<b>F8-6483</b>	<b>F8-6598</b>	<b>F8-6786</b>	<b>F8-6796</b>	<b>F8-7045</b>	<b>F8-7094</b>	<b>F8-7173</b>
Ref.Nr.: 77 00 832 256	Ref.Nr.: 77 00 437 854	Ref.Nr.: 7700847383	Ref.Nr.: 7700784170	Ref.Nr.: 7700779772	Ref.Nr.: 8200392683	Ref.Nr.: 7664079
<b>F8-7654</b>	<b>F8-7905</b>	<b>F8-7942</b>	<b>F8-8146</b>	<b>G9-569</b>		
Ref.Nr.: 7700109260	Ref.Nr.: 82 00 150 759	Ref.Nr.: 7700784171	Ref.Nr.: 7700425757	Ref.Nr.: 7700789478		

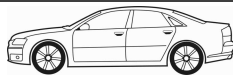
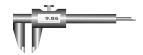
**Article Description****Article Nr.****Fitting Position**

<b>MEGANE I Coach (DA0/1_)</b>			<b>03/1996 → 08/2003</b>		
Control Arm-/Trailing Arm Bush	1.4 16V, 1.6 16V, 1.6 e, 2.0 i		<b>G9-569</b>		H=46; d=12; D1=45; D2=48
Control Arm-/Trailing Arm Bush	1.9 dTi, 2.0 16V, 2.0 16V IDE		<b>G9-653</b>		H1=35; H2=46; d=12; D=45
Bellow, steering	All Models	for steering gear ID: SMI; with clamps;	<b>LM-10000S</b>		d1=9; d2=39; L [mm]=168
Bellow, steering	1.4 16V, 1.6 16V, 1.6 e, 1.9 dCi, 1.9 dTi, 2.0 16V, 2.0 16V IDE, 2.0 i	; Manufacturer Restriction: TRW; with clamps;	<b>LM-10009S</b>		d1=12; d2=40; L [mm]=170
Bellow, steering	1.4 16V, 1.6 16V, 1.6 e, 1.9 dCi, 1.9 dTi, 2.0 16V, 2.0 16V IDE, 2.0 i	; with clamps	<b>LM-10009S</b>		d1=12; d2=40; L [mm]=170
Bellow, steering	1.4 16V, 1.6 16V, 1.6 e, 1.9 dCi, 1.9 dTi, 2.0 16V, 2.0 16V IDE, 2.0 i	; Manufacturer Restriction: TRW; with clamps;	<b>LM-10028S</b>		d1=12; d2=44; L [mm]=170
Bellow, steering	1.4 16V, 1.6 16V, 1.6 e, 1.9 dCi, 1.9 dTi, 2.0 16V, 2.0 16V IDE, 2.0 i	; with clamps	<b>LM-10028S</b>		d1=12; d2=44; L [mm]=170
Bellow Set, drive shaft	1.4 16V, 1.6 16V, 1.6 e, 2.0 i		<b>M-850850</b>		H=120; d1=28; d2=75.5
Bellow Set, drive shaft	1.6 e		<b>M-870870</b>		
Bellow Set, drive shaft	1.4 16V, 1.6 16V, 1.6 e, 2.0 i	ABS;	<b>MK-850850</b>		
<b>MEGANE I Grandtour (KA0/1_)</b>			<b>03/1999 → 08/2003</b>		
Dust Cover Kit, shock absorber	1.4 16V, 1.4 e, 1.6 16V, 1.6 e, 1.8 16V, 1.9 D, 1.9 dCi, 1.9 dTi		<b>AK-735042</b>		
Alternator Freewheel Clutch	1.9 dCi, 1.9 dTi		<b>F5-1014</b>		
Alternator Freewheel Clutch	1.4 16V, 1.6 16V, 1.9 dTi		<b>F5-1029</b>		
Alternator Freewheel Clutch	1.4 16V, 1.4 e, 1.6 16V		<b>F5-1061</b>		
Anti-Friction Bearing	1.4 16V, 1.4 e, 1.6 16V, 1.6 e, 1.9 D, 1.9 dTi		<b>F8-3033</b>		H=20; d1=62; d2=64; D=100
Engine Mounting	1.6 e		<b>F8-4109</b>		
Engine Mounting	1.9 dTi		<b>F8-5472</b>		
Top Strut Mounting	1.4 16V	; Type: KA0W	<b>F8-5473</b>		
Top Strut Mounting	1.4 e, 1.6 e, 1.9 D, 1.9 dTi		<b>F8-5473</b>		
Top Strut Mounting	1.6 16V	; Type: KA04	<b>F8-5473</b>		
Engine Mounting	1.4 16V	K4J 750	<b>F8-5476</b>		
Engine Mounting	1.6 16V		<b>F8-5476</b>		
Engine Mounting	1.6 e		<b>F8-5482</b>		
Mounting, automatic transmission	1.4 16V	Type: KA0W	<b>F8-5485</b>		
Mounting, automatic transmission	1.4 e, 1.9 D, 1.9 dTi		<b>F8-5485</b>		
Mounting, automatic transmission	1.6 16V	Type: KA04	<b>F8-5485</b>		
Mounting, automatic transmission	1.6 e		<b>F8-5485</b>		
Belt Pulley, crankshaft	1.9 D		<b>F8-5645</b>		

<b>AK-735042</b>	<b>F5-1014</b>	<b>F5-1029</b>	<b>F5-1061</b>	<b>F8-3033</b>	<b>F8-4109</b>	<b>F8-5472</b>
Ref.Nr.: 7700776743	Ref.Nr.: 8641982	Ref.Nr.: 7700110616	Ref.Nr.: 7700110616	Ref.Nr.: 7700797666	Ref.Nr.: 7700785949	Ref.Nr.: 7700832262
<b>F8-5473</b>	<b>F8-5476</b>	<b>F8-5482</b>	<b>F8-5485</b>	<b>F8-5645</b>	<b>F8-5656</b>	<b>G9-569</b>
Ref.Nr.: 7700780875	Ref.Nr.: 7700832264	Ref.Nr.: 7700794601	Ref.Nr.: 7700788318	Ref.Nr.: 7700724249	Ref.Nr.: 7700115309	Ref.Nr.: 7700789478
<b>G9-653</b>	<b>LM-10000S</b>	<b>LM-10009S</b>	<b>LM-10028S</b>	<b>M-850850</b>	<b>M-870870</b>	<b>MK-850850</b>
Ref.Nr.: 7700789477	Ref.Nr.: 6000025546	Ref.Nr.: 7701469486	Ref.Nr.: 7701469487	Ref.Nr.: 329373	Ref.Nr.: 7701450617	Ref.Nr.: 329373

Article Description

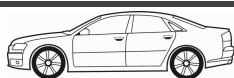

Article Nr.

Fitting Position



MEGANE I Grandtour (KA0/1_)			03/1999 → 08/2003		
Belt Pulley, crankshaft	1.9 dCi	F9Q 732	<b>F8-5656</b>		
Belt Pulley, crankshaft	1.9 dTi		<b>F8-5656</b>		
Mounting, axle beam	1.4 16V , 1.4 e , 1.6 16V , 1.6 e , 1.8 16V , 1.9 D , 1.9 dTi		<b>F8-6156</b>		H1=73; H2=37; d=32; D1=72; D2=40
Mounting, axle beam	1.9 dCi	F9Q 732, F9Q 733	<b>F8-6156</b>		H1=73; H2=37; d=32; D1=72; D2=40
Gear, camshaft	1.9 dTi	10/2000 →; Engine Management: Timing Belt;  40	<b>F8-6254</b>		d=13; D=120; W=30
Gear, camshaft	1.9 dTi	Engine Management: Timing Belt;  40	<b>F8-6254</b>		d=13; D=120; W=30
Top Strut Mounting	1.4 16V	; Type: KA0D, KA0W, KA10	<b>F8-6379</b>		
Top Strut Mounting	1.4 e , 1.6 16V , 1.6 e , 1.9 dTi		<b>F8-6379</b>		
Top Strut Mounting	1.8 16V	; Type: KA12, KA1A, KA1M	<b>F8-6379</b>		
Top Strut Mounting	1.9 D	; Type: KA0J	<b>F8-6379</b>		
Top Strut Mounting	1.9 dCi	; Type: KA01, KA05, KA1F	<b>F8-6379</b>		
Engine Mounting	1.8 16V	F4P 720, F4P 722; Aluminium	<b>F8-6482</b>		
Engine Mounting	1.9 dCi , 1.9 dTi	Aluminium	<b>F8-6482</b>		
Engine Mounting	1.9 dTi	Aluminium;	<b>F8-6482</b>		
Engine Mounting	1.9 D , 1.9 dCi , 1.9 dTi		<b>F8-6483</b>		
Engine Mounting	1.4 16V , 1.6 16V	11/1999 →	<b>F8-6598</b>		
Stabiliser Mounting	1.9 D , 1.9 dTi		<b>F8-6786</b>		
Stabiliser Mounting	1.4 16V , 1.4 e , 1.6 16V , 1.6 e , 1.8 16V , 1.9 D , 1.9 dCi , 1.9 dTi		<b>F8-6796</b>		d=18
Belt Pulley, crankshaft	1.4 16V , 1.6 16V	Number of Ribs: 6	<b>F8-7094</b>		Belt Pulley Ø [mm]=134; Mounting points diam.[mm]=26; W=33
Bearing, drive shaft	1.4 16V , 1.4 e , 1.6 16V , 1.6 e		<b>F8-7173</b>		d=25.8
Stabiliser Mounting	1.4 16V		<b>F8-7905</b>		d=24,5
Stabiliser Mounting	1.4 e , 1.6 e	Engine980709→	<b>F8-7905</b>		d=24,5
Stabiliser Mounting	1.6 16V	Engine: K4M 700, K4M 701	<b>F8-7905</b>		d=24,5
Stabiliser Mounting	1.4 16V , 1.4 e , 1.6 16V , 1.6 e , 1.8 16V , 1.9 D , 1.9 dCi , 1.9 dTi		<b>F8-7942</b>		
Engine Mounting	1.4 16V , 1.4 e , 1.6 16V , 1.8 16V , 1.9 D , 1.9 dTi		<b>F8-8146</b>		
Control Arm-/Trailing Arm Bush	1.4 16V , 1.4 e , 1.6 16V , 1.6 e		<b>G9-569</b>		H=46; d=12; D1=45; D2=48
Control Arm-/Trailing Arm Bush	1.9 D , 1.9 dTi		<b>G9-653</b>		H1=35; H2=46; d=12; D=45
Bellow, steering	1.4 16V , 1.4 e , 1.6 16V , 1.6 e , 1.8 16V , 1.9 D , 1.9 dCi , 1.9 dTi	for steering gear ID: SMI; with clamps;	<b>LM-10000S</b>		d1=9; d2=39; L [mm]=168
Bellow, steering	1.4 16V , 1.4 e , 1.6 16V , 1.6 e , 1.8 16V , 1.9 D , 1.9 dCi , 1.9 dTi	Manufacturer Restriction: TRW; with clamps;	<b>LM-10009S</b>		d1=12; d2=40; L [mm]=170

<b>F8-5656</b>	<b>F8-6156</b>	<b>F8-6254</b>	<b>F8-6379</b>	<b>F8-6482</b>	<b>F8-6483</b>	<b>F8-6598</b>
Ref.Nr.: 7700115309	Ref.Nr.: 7700762844	Ref.Nr.: 8200125710	Ref.Nr.: 7700797654	Ref.Nr.: 82 00 148 388	Ref.Nr.: 77 00 832 256	Ref.Nr.: 77 00 437 854
<b>F8-6786</b>	<b>F8-6796</b>	<b>F8-7094</b>	<b>F8-7173</b>	<b>F8-7905</b>	<b>F8-7942</b>	<b>F8-8146</b>
Ref.Nr.: 7700847383	Ref.Nr.: 7700784170	Ref.Nr.: 8200392683	Ref.Nr.: 7664079	Ref.Nr.: 82 00 150 759	Ref.Nr.: 7700784171	Ref.Nr.: 7700425757
<b>G9-569</b>	<b>G9-653</b>	<b>LM-10000S</b>	<b>LM-10009S</b>			
Ref.Nr.: 7700789478	Ref.Nr.: 7700789477	Ref.Nr.: 6000025546	Ref.Nr.: 7701469486			





Article Description



Article Nr.

Fitting Position



MEGANE II (BM0/1, CM0/1)		11/2002 → 12/2009	
Dust Cover Kit, shock absorber	1.4 16V, 1.5 dCi, 1.6 16V, 1.9 dCi, 2.0 16V, 2.0 16V Turbo, 2.0 dCi	AK-735061	
Alternator Freewheel Clutch	1.9 dCi	F5-1025	
Alternator Freewheel Clutch	1.9 dCi	F5-1036	
Alternator Freewheel Clutch	1.4 16V	K4J 740	F5-1061
Alternator Freewheel Clutch	1.5 dCi, 1.6, 1.6 Flex-Fuel		F5-1061
Alternator Freewheel Clutch	1.6 16V	K4M 812, K4M 813	F5-1061
Alternator Freewheel Clutch	1.4 16V, 1.6, 1.6 16V, 1.6 Flex-Fuel		F5-1062
Alternator Freewheel Clutch	2.0 dCi		F5-1063
Alternator Freewheel Clutch	1.9 dCi		F5-1093
Alternator Freewheel Clutch	2.0 dCi		F5-1110
Alternator Freewheel Clutch	1.4 16V, 1.5 dCi, 1.6, 1.6 16V, 1.6 Flex-Fuel		F5-1122
Alternator Freewheel Clutch	1.5 dCi		F5-1130
Belt Pulley, crankshaft	1.5 dCi		F8-5657
Belt Pulley, crankshaft	1.5 dCi	K9K 728	F8-5657
Top Strut Mounting	1.4 16V, 1.5 dCi, 1.6, 1.6 16V, 1.6 Flex-Fuel, 1.9 dCi, 2.0, 2.0 16V, 2.0 16V Turbo, 2.0 dCi, 2.0 Renault Sport		F8-6175
Top Strut Mounting	1.4 16V, 1.5 dCi, 1.6, 1.6 16V, 1.6 Flex-Fuel, 1.9 dCi, 2.0, 2.0 16V, 2.0 16V Turbo, 2.0 dCi, 2.0 Renault Sport		F8-6195
Anti-Friction Bearing	1.4 16V, 1.5 dCi, 1.6, 1.6 16V, 1.6 Flex-Fuel, 1.9 dCi, 2.0, 2.0 16V, 2.0 16V Turbo, 2.0 dCi, 2.0 Renault Sport		F8-6335
Engine Mounting	1.9 dCi, 2.0, 2.0 16V, 2.0 16V Turbo, 2.0 dCi, 2.0 Renault Sport		F8-6420
Engine Mounting	1.5 dCi		F8-6522
Engine Mounting	1.9 dCi, 2.0 16V		F8-6676
Engine Mounting	1.5 dCi		F8-6677
Engine Mounting	1.5 dCi, 2.0 dCi		F8-6678
Mounting, axle beam	1.4 16V, 1.5 dCi, 1.6, 1.6 16V, 1.6 Flex-Fuel, 1.9 dCi, 2.0, 2.0 16V, 2.0 16V Turbo, 2.0 dCi, 2.0 Renault Sport		F8-6679
Engine Mounting	1.5 dCi		F8-6680
Holder, engine mounting	1.4 16V, 1.5 dCi, 1.6 16V, 2.0 16V		F8-6681
Holder, engine mounting	1.4 16V, 1.5 dCi, 1.6 16V, 1.9 dCi, 2.0 16V		F8-6682
Mounting, support frame/engine carrier	1.4 16V, 1.5 dCi, 1.6, 1.6 16V, 1.6 Flex-Fuel, 1.9 dCi, 2.0, 2.0 16V, 2.0 16V Turbo, 2.0 dCi, 2.0 Renault Sport		F8-6715

<b>AK-735061</b>	<b>F5-1025</b>	<b>F5-1036</b>	<b>F5-1061</b>	<b>F5-1062</b>	<b>F5-1063</b>	<b>F5-1093</b>
Ref.Nr.: 8200040073	Ref.Nr.: 23151-00Q0B	Ref.Nr.: 23151-00Q0A	Ref.Nr.: 7700110616	Ref.Nr.: 7701476465	Ref.Nr.:	Ref.Nr.:
<b>F5-1110</b>	<b>F5-1122</b>	<b>F5-1130</b>	<b>F8-5657</b>	<b>F8-6175</b>	<b>F8-6195</b>	<b>F8-6335</b>
Ref.Nr.: 8200489514	Ref.Nr.:	Ref.Nr.: 23151-3VD1A	Ref.Nr.: 8200185800	Ref.Nr.: 8200222463	Ref.Nr.: 7701207678	Ref.Nr.: 7701208891
<b>F8-6420</b>	<b>F8-6522</b>	<b>F8-6676</b>	<b>F8-6677</b>	<b>F8-6678</b>	<b>F8-6679</b>	<b>F8-6680</b>
Ref.Nr.: 8200338381	Ref.Nr.: 8200338385	Ref.Nr.: 11350-BV000	Ref.Nr.: 8200325283	Ref.Nr.: 8200355673	Ref.Nr.: 8200038243	Ref.Nr.: 8200042453

Article Description



Article Nr.

Fitting Position



<b>MEGANE II (BM0/1_, CM0/1_)</b>			<b>11/2002 → 12/2009</b>	
Belt Pulley, crankshaft	1.9 dCi	06/2004 →; Number of Ribs: 7	<b>F8-7093</b>	Belt Pulley Ø [mm]=155; Mounting points diam.[mm]=25; W=41
Belt Pulley, crankshaft	1.9 dCi	Number of Ribs: 7	<b>F8-7093</b>	Belt Pulley Ø [mm]=155; Mounting points diam.[mm]=25; W=41
Belt Pulley, crankshaft	1.9 dCi		<b>F8-7093S1</b>	
Belt Pulley, crankshaft	2.0 16V		<b>F8-7656</b>	
Belt Pulley, crankshaft	2.0 dCi	Number of Ribs: 6; Parameter: 7PK	<b>F8-7657</b>	
Engine Mounting	1.5 dCi		<b>F8-7746</b>	⊕
Control Arm-/Trailing Arm Bush	1.4 16V , 1.5 dCi , 1.6, 1.6 16V , 1.6 Flex-Fuel, 1.9 dCi , 2.0, 2.0 16V , 2.0 16V Turbo, 2.0 dCi , 2.0 Renault Sport		<b>F8-7989</b>	⊕
Control Arm-/Trailing Arm Bush	1.4 16V , 1.5 dCi , 1.6, 1.6 16V , 1.6 Flex-Fuel, 1.9 dCi , 2.0, 2.0 16V , 2.0 16V Turbo, 2.0 dCi , 2.0 Renault Sport		<b>F8-7992</b>	⊕
Engine Mounting	1.5 dCi, 1.9 dCi , 2.0, 2.0 16V , 2.0 16V Turbo, 2.0 Renault Sport		<b>F8-8162</b>	
Engine Mounting	1.4 16V , 1.6, 1.6 16V , 1.6 Bifuel, 1.6 Flex-Fuel		<b>F8-8168</b>	⊕
<b>MEGANE II Coupé-Cabriolet (EM0/1_)</b>			<b>09/2003 → 12/2009</b>	
Dust Cover Kit, shock absorber	1.6, 1.9 dCi, 2.0, 2.0 16V Turbo, 2.0 dCi		<b>AK-735061</b>	⊕ ⊕
Alternator Freewheel Clutch	1.5 dCi		<b>F5-1061</b>	
Alternator Freewheel Clutch	1.6 16V	K4M 812, K4M 813	<b>F5-1061</b>	
Alternator Freewheel Clutch	1.6, 1.6 16V		<b>F5-1062</b>	
Alternator Freewheel Clutch	2.0 dCi		<b>F5-1063</b>	
Alternator Freewheel Clutch	2.0 dCi		<b>F5-1110</b>	
Alternator Freewheel Clutch	1.5 dCi , 1.6, 1.6 16V		<b>F5-1122</b>	
Alternator Freewheel Clutch	1.5 dCi		<b>F5-1130</b>	
Top Strut Mounting	1.5 dCi , 1.6, 1.6 16V, 1.9 dCi, 2.0, 2.0 16V Turbo, 2.0 dCi		<b>F8-6175</b>	⊕ ⊕
Top Strut Mounting	1.5 dCi , 1.6, 1.6 16V, 1.9 dCi, 2.0, 2.0 16V Turbo, 2.0 dCi		<b>F8-6195</b>	⊕ ⊕
Anti-Friction Bearing	1.5 dCi , 1.6, 1.6 16V, 1.9 dCi, 2.0, 2.0 16V Turbo, 2.0 dCi		<b>F8-6335</b>	
Engine Mounting	1.9 dCi, 2.0, 2.0 16V Turbo		<b>F8-6420</b>	⊕
Engine Mounting	1.9 dCi, 2.0		<b>F8-6676</b>	⊕ ↑
Engine Mounting	1.5 dCi		<b>F8-6677</b>	⊕
Engine Mounting	1.5 dCi , 2.0 dCi		<b>F8-6678</b>	⊕ ⊕ ↑
Mounting, axle beam	1.5 dCi , 1.6, 1.6 16V, 1.9 dCi, 2.0, 2.0 16V Turbo, 2.0 dCi		<b>F8-6679</b>	⊕ ⊕ d=12; D=70

<b>AK-735061</b>	<b>F5-1061</b>	<b>F5-1062</b>	<b>F5-1063</b>	<b>F5-1110</b>	<b>F5-1122</b>	<b>F5-1130</b>
Ref.Nr.: 8200040073	Ref.Nr.: 7700110616	Ref.Nr.: 7701476465	Ref.Nr.:	Ref.Nr.: 8200489514	Ref.Nr.:	Ref.Nr.: 23151-3VD1A
<b>F8-6175</b>	<b>F8-6195</b>	<b>F8-6335</b>	<b>F8-6420</b>	<b>F8-6676</b>	<b>F8-6677</b>	<b>F8-6678</b>
Ref.Nr.: 8200222463	Ref.Nr.: 7701207678	Ref.Nr.: 7701208891	Ref.Nr.: 8200338381	Ref.Nr.: 11350-BV000	Ref.Nr.: 8200325283	Ref.Nr.: 8200355673
<b>F8-6679</b>	<b>F8-6680</b>	<b>F8-7093</b>	<b>F8-7093S1</b>	<b>F8-7656</b>	<b>F8-7657</b>	<b>F8-7746</b>
Ref.Nr.: 8200038243	Ref.Nr.: 8200042453	Ref.Nr.: 8200457775	Ref.Nr.: 12303AW300	Ref.Nr.: 8200619927	Ref.Nr.: 1230300Q0A	Ref.Nr.: 8200042456



Article Description



Article Nr.

Fitting Position



<b>MEGANE II Coupé-Cabriolet (EM0/1_)</b>			<b>09/2003 → 12/2009</b>		
Engine Mounting	1.5 dCi		<b>F8-6680</b>		L=185
Holder, engine mounting	2.0		<b>F8-6681</b>		
Mounting, support frame/engine carrier	1.5 dCi , 1.6, 1.6 16V, 1.9 dCi, 2.0, 2.0 16V Turbo, 2.0 dCi		<b>F8-6715</b>		H=82; d=17; D=41
Belt Pulley, crankshaft	1.9 dCi	Number of Ribs: 7	<b>F8-7093</b>		Belt Pulley Ø [mm]=155; Mounting points diam.[mm]=25; W=41
Belt Pulley, crankshaft	2.0 dCi	Number of Ribs: 6; Parameter: 7PK	<b>F8-7657</b>		
Control Arm-/Trailing Arm Bush	1.5 dCi , 1.6, 1.6 16V, 1.9 dCi, 2.0, 2.0 16V Turbo, 2.0 dCi		<b>F8-7989</b>		d=12; D=24, 58; Thick. [mm]=53
Control Arm-/Trailing Arm Bush	1.5 dCi , 1.6, 1.6 16V, 1.9 dCi, 2.0, 2.0 16V Turbo, 2.0 dCi		<b>F8-7992</b>		d=12; D=33, 43; Thick. [mm]=48
Engine Mounting	1.5 dCi , 1.9 dCi, 2.0, 2.0 16V Turbo		<b>F8-8162</b>		
Engine Mounting	1.6, 1.6 16V		<b>F8-8168</b>		
<b>MEGANE II Sport Tourer (KM0/1_)</b>			<b>08/2003 → 08/2009</b>		
Dust Cover Kit, shock absorber	1.4, 1.5 dCi, 1.6, 1.9 dCi, 2.0, 2.0 dCi		<b>AK-735061</b>		
Alternator Freewheel Clutch	1.4	K4J 740	<b>F5-1061</b>		
Alternator Freewheel Clutch	1.5 dCi, 1.6 16V Hi-Flex		<b>F5-1061</b>		
Alternator Freewheel Clutch	1.6 16V	K4M 812, K4M 813	<b>F5-1061</b>		
Alternator Freewheel Clutch	1.4, 1.6, 1.6 16V, 1.6 16V Hi-Flex		<b>F5-1062</b>		
Alternator Freewheel Clutch	2.0 dCi		<b>F5-1063</b>		
Alternator Freewheel Clutch	2.0 dCi		<b>F5-1110</b>		
Alternator Freewheel Clutch	1.4, 1.5 dCi , 1.6, 1.6 16V, 1.6 16V Hi-Flex		<b>F5-1122</b>		
Alternator Freewheel Clutch	1.5 dCi		<b>F5-1130</b>		
Belt Pulley, crankshaft	1.5 dCi	K9K 728, K9K 729	<b>F8-5657</b>		
Belt Pulley, crankshaft	1.5 dCi, 1.6 16V		<b>F8-5657</b>		
Top Strut Mounting	1.4, 1.5 dCi, 1.6, 1.6 16V, 1.6 16V Hi-Flex, 1.9 dCi, 2.0, 2.0 dCi		<b>F8-6175</b>		
Top Strut Mounting	1.4, 1.5 dCi, 1.6, 1.6 16V, 1.6 16V Hi-Flex, 1.9 dCi, 2.0, 2.0 dCi		<b>F8-6195</b>		
Anti-Friction Bearing	1.4, 1.5 dCi, 1.6, 1.6 16V, 1.6 16V Hi-Flex, 1.9 dCi, 2.0, 2.0 dCi		<b>F8-6335</b>		
Engine Mounting	1.9 dCi		<b>F8-6420</b>		
Engine Mounting	1.9 dCi	F9Q 803	<b>F8-6420</b>		
Engine Mounting	2.0	F4R 770, F4R 771	<b>F8-6420</b>		
Engine Mounting	1.5 dCi		<b>F8-6522</b>		L=265
Engine Mounting	1.9 dCi, 2.0		<b>F8-6676</b>		
Engine Mounting	1.5 dCi		<b>F8-6677</b>		

<b>AK-735061</b>	<b>F5-1061</b>	<b>F5-1062</b>	<b>F5-1063</b>	<b>F5-1110</b>	<b>F5-1122</b>	<b>F5-1130</b>
Ref.Nr.: 8200040073	Ref.Nr.: 7700110616	Ref.Nr.: 7701476465	Ref.Nr.:	Ref.Nr.: 8200489514	Ref.Nr.:	Ref.Nr.: 23151-3VD1A
<b>F8-5657</b>	<b>F8-6175</b>	<b>F8-6195</b>	<b>F8-6335</b>	<b>F8-6420</b>	<b>F8-6522</b>	<b>F8-6676</b>
Ref.Nr.: 8200185800	Ref.Nr.: 8200222463	Ref.Nr.: 7701207678	Ref.Nr.: 7701208891	Ref.Nr.: 8200338381	Ref.Nr.: 8200338385	Ref.Nr.: 11350-BV000
<b>F8-6677</b>	<b>F8-6678</b>	<b>F8-6680</b>	<b>F8-6681</b>	<b>F8-6715</b>	<b>F8-7093</b>	<b>F8-7657</b>
Ref.Nr.: 8200325283	Ref.Nr.: 8200355673	Ref.Nr.: 8200042453	Ref.Nr.: 8200197453	Ref.Nr.: 8200742906	Ref.Nr.: 8200457775	Ref.Nr.: 1230300Q0A

Article Description



Article Nr.

Fitting Position



<b>MEGANE II Sport Tourer (KM0/1_)</b>		<b>08/2003 → 08/2009</b>	
Engine Mounting	1.5 dCi	<b>F8-6678</b>	
Mounting, axle beam	1.4, 1.5 dCi, 1.6, 1.6 16V, 1.6 16V Hi-Flex, 1.9 dCi, 2.0, 2.0 dCi	<b>F8-6679</b>	d=12; D=70
Engine Mounting	1.5 dCi	<b>F8-6680</b>	L=185
Mounting, support frame/engine carrier	1.4, 1.5 dCi, 1.6, 1.6 16V, 1.6 16V Hi-Flex, 1.9 dCi, 2.0, 2.0 dCi	<b>F8-6715</b>	H=82; d=17; D=41
Belt Pulley, crankshaft	1.9 dCi	<b>F8-7093</b>	06/2004 →; Number of Ribs: 7 Belt Pulley Ø [mm]=155; Mounting points diam.[mm]=25; W=41
Belt Pulley, crankshaft	1.9 dCi	<b>F8-7093</b>	09/2003 →; Number of Ribs: 7 Belt Pulley Ø [mm]=155; Mounting points diam.[mm]=25; W=41
Belt Pulley, crankshaft	1.9 dCi	<b>F8-7093</b>	Number of Ribs: 7 Belt Pulley Ø [mm]=155; Mounting points diam.[mm]=25; W=41
Belt Pulley, crankshaft	2.0 dCi	<b>F8-7657</b>	Number of Ribs: 6; Parameter: 7PK
Engine Mounting	1.5 dCi	<b>F8-7746</b>	
Control Arm-/Trailing Arm Bush	1.4, 1.5 dCi, 1.6, 1.6 16V, 1.6 16V Hi-Flex, 1.9 dCi, 2.0, 2.0 dCi	<b>F8-7989</b>	d=12; D=24, 58; Thick. [mm]=53
Control Arm-/Trailing Arm Bush	1.4, 1.5 dCi, 1.6, 1.6 16V, 1.6 16V Hi-Flex, 1.9 dCi, 2.0, 2.0 dCi	<b>F8-7992</b>	d=12; D=33, 43; Thick. [mm]=48
Engine Mounting	1.5 dCi, 1.9 dCi	<b>F8-8162</b>	
Engine Mounting	1.4, 1.6, 1.6 16V, 1.6 16V Hi-Flex	<b>F8-8168</b>	
<b>MEGANE II Saloon (LM0/1_)</b>		<b>09/2003 → 12/2005</b>	
Dust Cover Kit, shock absorber	1.4, 1.5 dCi, 1.6, 1.9 dCi, 2.0	<b>AK-735061</b>	
Alternator Freewheel Clutch	1.4	<b>F5-1061</b>	
Alternator Freewheel Clutch	1.5 dCi, 1.6, 1.6 16V	<b>F5-1061</b>	
Alternator Freewheel Clutch	1.4, 1.6, 1.6 16V	<b>F5-1062</b>	
Alternator Freewheel Clutch	2.0 dCi	<b>F5-1063</b>	
Alternator Freewheel Clutch	2.0 dCi	<b>F5-1110</b>	
Alternator Freewheel Clutch	1.4, 1.5 dCi, 1.6, 1.6 16V, 1.6 Hi-Flex	<b>F5-1122</b>	
Alternator Freewheel Clutch	1.5 dCi	<b>F5-1130</b>	
Belt Pulley, crankshaft	1.5 dCi	<b>F8-5657</b>	
Top Strut Mounting	1.4, 1.5 dCi, 1.6, 1.6 16V, 1.9 dCi, 2.0, 2.0 dCi	<b>F8-6175</b>	
Top Strut Mounting	1.4, 1.5 dCi, 1.6, 1.6 16V, 1.9 dCi, 2.0, 2.0 dCi	<b>F8-6195</b>	
Anti-Friction Bearing	1.4, 1.5 dCi, 1.6, 1.6 16V, 1.9 dCi, 2.0, 2.0 dCi	<b>F8-6335</b>	
Engine Mounting	1.9 dCi, 2.0	<b>F8-6420</b>	
Engine Mounting	1.4, 1.5 dCi	<b>F8-6522</b>	L=265
Engine Mounting	1.9 dCi, 2.0	<b>F8-6676</b>	

<b>AK-735061</b>	<b>F5-1061</b>	<b>F5-1062</b>	<b>F5-1063</b>	<b>F5-1110</b>	<b>F5-1122</b>	<b>F5-1130</b>
Ref.Nr.: 8200040073	Ref.Nr.: 7700110616	Ref.Nr.: 7701476465	Ref.Nr.:	Ref.Nr.: 8200489514	Ref.Nr.:	Ref.Nr.: 23151-3VD1A
<b>F8-5657</b>	<b>F8-6175</b>	<b>F8-6195</b>	<b>F8-6335</b>	<b>F8-6420</b>	<b>F8-6522</b>	<b>F8-6676</b>
Ref.Nr.: 8200185800	Ref.Nr.: 8200222463	Ref.Nr.: 7701207678	Ref.Nr.: 7701208891	Ref.Nr.: 8200338381	Ref.Nr.: 8200338385	Ref.Nr.: 11350-BV000
<b>F8-6677</b>	<b>F8-6678</b>	<b>F8-6679</b>	<b>F8-6680</b>	<b>F8-6715</b>	<b>F8-7093</b>	<b>F8-7657</b>
Ref.Nr.: 8200325283	Ref.Nr.: 8200355673	Ref.Nr.: 8200038243	Ref.Nr.: 8200042453	Ref.Nr.: 8200742906	Ref.Nr.: 8200457775	Ref.Nr.: 1230300Q0A

Alle in diesem Katalog genannten Original-Nummern der Kfz-Hersteller sind ausschließlich zu Vergleichszwecken bestimmt und dürfen in Rechnungen an Wagenbesitzer nicht verwendet werden. All original numbers from automobile manufacturers listed in this catalogue are for comparison purposes only and may not be used in invoices to car owners.

Nachdruck, auch auszugsweise, nur mit unserer schriftlichen Genehmigung gestattet. - Full or partial reproduction only permitted with our approval.

Les références des constructeurs n'ont aucune valeur et ne sont indiquées qu'à titre d'identification. La reproduction complète ou partielle de notre catalogue est interdite sans notre accord écrit.

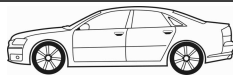
**Article Description****Article Nr.****Fitting Position**

<b>MEGANE II Saloon (LM0/1_)</b>			<b>09/2003 → 12/2005</b>		
Engine Mounting	1.5 dCi		<b>F8-6677</b>		
Engine Mounting	1.5 dCi, 2.0 dCi		<b>F8-6678</b>		
Mounting, axle beam	1.4, 1.5 dCi, 1.6, 1.6 16V, 1.9 dCi , 2.0, 2.0 dCi		<b>F8-6679</b>		d=12; D=70
Engine Mounting	1.5 dCi		<b>F8-6680</b>		L=185
Holder, engine mounting	1.4, 1.9 dCi , 2.0		<b>F8-6681</b>		
Holder, engine mounting	1.5 dCi, 1.9 dCi		<b>F8-6682</b>		
Mounting, support frame/engine carrier	1.4, 1.5 dCi, 1.6, 1.6 16V, 1.9 dCi , 2.0, 2.0 dCi		<b>F8-6715</b>		H=82; d=17; D=41
Belt Pulley, crankshaft	1.9 dCi	06/2004 →; Number of Ribs: 7	<b>F8-7093</b>		Belt Pulley Ø [mm]=155; Mounting points diam.[mm]=25; W=41
Belt Pulley, crankshaft	1.9 dCi	Number of Ribs: 7	<b>F8-7093</b>		Belt Pulley Ø [mm]=155; Mounting points diam.[mm]=25; W=41
Engine Mounting	1.5 dCi		<b>F8-7746</b>		
Control Arm-/Trailing Arm Bush	1.4, 1.5 dCi, 1.6, 1.6 16V, 1.6 Hi-Flex, 1.9 dCi , 2.0, 2.0 dCi		<b>F8-7989</b>		d=12; D=24, 58; Thick. [mm]=53
Control Arm-/Trailing Arm Bush	1.4, 1.5 dCi, 1.6, 1.6 16V, 1.9 dCi , 2.0		<b>F8-7992</b>		d=12; D=33, 43; Thick. [mm]=48
Engine Mounting	1.5 dCi, 1.9 dCi , 2.0		<b>F8-8162</b>		
Engine Mounting	1.4, 1.6, 1.6 16V, 1.6 Hi-Flex		<b>F8-8168</b>		
<b>MEGANE III Coupe (DZ0/1_)</b>			<b>11/2008 →</b>		
Dust Cover Kit, shock absorber	1.4 TCe , 1.5 dCi , 1.6 16V , 1.6 16V Bifuel , 1.9 dCi , 2.0 CVT , 2.0 dCi , 2.0 TCe		<b>AK-735444</b>		H=140
Alternator Freewheel Clutch	2.0 CVT		<b>F5-1025</b>		
Alternator Freewheel Clutch	1.5 dCi		<b>F5-1061</b>		
Alternator Freewheel Clutch	1.9 dCi		<b>F5-1063</b>		
Alternator Freewheel Clutch	1.2 TCe, 1.6 dCi , 1.9 dCi , 2.0 CVT , 2.0 R.S., 2.0 TCe		<b>F5-1110</b>		
Alternator Freewheel Clutch	1.6 16V , 1.6 16V Bifuel		<b>F5-1122</b>		
Alternator Freewheel Clutch	1.2 TCe, 1.4 TCe , 1.6 dCi , 2.0 dCi		<b>F5-1129</b>		
Alternator Freewheel Clutch	1.5 dCi		<b>F5-1130</b>		
Belt Pulley, crankshaft	1.5 dCi		<b>F8-5657</b>		
Anti-Friction Bearing	1.4 TCe , 1.5 dCi , 1.6 16V , 1.6 16V Bifuel , 1.9 dCi , 2.0 CVT , 2.0 dCi , 2.0 TCe		<b>F8-7637</b>		H=34; d=99; D1=140; D2=108
<b>MEGANE III Grandtour (KZ0/1)</b>			<b>11/2008 →</b>		
Dust Cover Kit, shock absorber	1.4 TCe , 1.5 dCi , 1.6 16V , 1.6 16V Bifuel , 1.9 dCi , 2.0 CVT , 2.0 dCi , 2.0 TCe		<b>AK-735444</b>		H=140
Alternator Freewheel Clutch	2.0 CVT		<b>F5-1025</b>		

<b>AK-735444</b>	<b>F5-1025</b>	<b>F5-1061</b>	<b>F5-1063</b>	<b>F5-1110</b>	<b>F5-1122</b>	<b>F5-1129</b>
Ref.Nr.: 540500016R	Ref.Nr.: 23151-00Q0B	Ref.Nr.: 7700110616	Ref.Nr.:	Ref.Nr.: 8200489514	Ref.Nr.:	Ref.Nr.: 23151-JG71B
<b>F5-1130</b>	<b>F8-5657</b>	<b>F8-6677</b>	<b>F8-6678</b>	<b>F8-6679</b>	<b>F8-6680</b>	<b>F8-6681</b>
Ref.Nr.: 23151-3VD1A	Ref.Nr.: 8200185800	Ref.Nr.: 8200325283	Ref.Nr.: 8200355673	Ref.Nr.: 8200038243	Ref.Nr.: 8200042453	Ref.Nr.: 8200197453
<b>F8-6682</b>	<b>F8-6715</b>	<b>F8-7093</b>	<b>F8-7637</b>	<b>F8-7746</b>	<b>F8-7989</b>	<b>F8-7992</b>
Ref.Nr.: 8200197452	Ref.Nr.: 8200742906	Ref.Nr.: 8200457775	Ref.Nr.: 543250005R	Ref.Nr.: 8200042456	Ref.Nr.: 8200041166	Ref.Nr.: 8200242025

Article Description



Article Nr.

Fitting Position



<b>MEGANE III Grandtour (KZ0/1)</b>		<b>11/2008 →</b>	
Alternator Freewheel Clutch	1.5 dCi	<b>F5-1061</b>	
Alternator Freewheel Clutch	1.9 dCi	<b>F5-1063</b>	
Alternator Freewheel Clutch	1.2 TCe, 1.6 dCi, 1.9 dCi, 2.0 TCe	<b>F5-1110</b>	
Alternator Freewheel Clutch	1.5 dCi, 1.6 16V, 1.6 16V Bifuel	<b>F5-1122</b>	
Alternator Freewheel Clutch	1.2 TCe, 1.4 TCe, 1.6 dCi, 2.0 dCi	<b>F5-1129</b>	
Alternator Freewheel Clutch	1.5 dCi	<b>F5-1130</b>	
Belt Pulley, crankshaft	1.5 dCi	<b>F8-5657</b>	
Anti-Friction Bearing	1.4 TCe, 1.5 dCi, 1.6 16V, 1.6 16V Bifuel, 1.9 dCi, 2.0 CVT, 2.0 dCi, 2.0 TCe	<b>F8-7637</b>	⊕ ⊕ H=34; d=99; D1=140; D2=108
<b>MEGANE III Hatchback (BZ0_)</b>		<b>11/2008 →</b>	
Dust Cover Kit, shock absorber	1.4 TCe, 1.5 dCi, 1.6 16V, 1.6 16V Bifuel, 1.9 dCi, 2.0 CVT, 2.0 dCi, 2.0 TCe	<b>AK-735444</b>	⊕ ⊕ H=140
Alternator Freewheel Clutch	2.0 CVT	<b>F5-1025</b>	
Alternator Freewheel Clutch	1.5 dCi	<b>F5-1061</b>	
Alternator Freewheel Clutch	1.6 16V	<b>F5-1062</b>	
Alternator Freewheel Clutch	1.9 dCi	<b>F5-1063</b>	
Alternator Freewheel Clutch	1.2 TCe, 1.6 dCi, 1.9 dCi, 2.0 TCe	<b>F5-1110</b>	
Alternator Freewheel Clutch	1.6 16V, 1.6 16V Bifuel	<b>F5-1122</b>	
Alternator Freewheel Clutch	1.2 TCe, 1.4 TCe, 1.6 dCi, 2.0 dCi	<b>F5-1129</b>	
Alternator Freewheel Clutch	1.5 dCi	<b>F5-1130</b>	
Belt Pulley, crankshaft	1.5 dCi	<b>F8-5657</b>	
Anti-Friction Bearing	1.4 TCe, 1.5 dCi, 1.6 16V, 1.6 16V Bifuel, 1.9 dCi, 2.0 CVT, 2.0 dCi, 2.0 TCe	<b>F8-7637</b>	⊕ ⊕ H=34; d=99; D1=140; D2=108
<b>MEGANE CC (EZ0/1_)</b>		<b>06/2010 →</b>	
Dust Cover Kit, shock absorber	1.4 TCe, 1.5 dCi, 1.6 16V, 1.9 dCi, 2.0 CVT, 2.0 dCi, 2.0 TCe	<b>AK-735444</b>	⊕ ⊕ H=140
Alternator Freewheel Clutch	2.0 CVT	<b>F5-1025</b>	
Alternator Freewheel Clutch	1.5 dCi	<b>F5-1061</b>	
Alternator Freewheel Clutch	1.9 dCi	<b>F5-1063</b>	
Alternator Freewheel Clutch	1.6 dCi, 1.9 dCi, 2.0 TCe	<b>F5-1110</b>	
Alternator Freewheel Clutch	1.6 16V	<b>F5-1122</b>	
Alternator Freewheel Clutch	1.4 TCe, 1.6 dCi, 2.0 dCi	<b>F5-1129</b>	
Anti-Friction Bearing	1.4 TCe, 1.5 dCi, 1.6 16V, 1.9 dCi, 2.0 CVT, 2.0 dCi	<b>F8-7637</b>	⊕ ⊕ H=34; d=99; D1=140; D2=108
<b>MEGANE Scenic (JA0/1_)</b>		<b>10/1996 → 10/1999</b>	
Dust Cover Kit, shock absorber	1.4 i, 1.6 e, 1.6 i, 1.9 D, 1.9 dT, 1.9 dTi, 2.0 i	<b>AK-735042</b>	⊕ ⊕
Alternator Freewheel Clutch	1.9 dTi	<b>F5-1014</b>	





Article Description

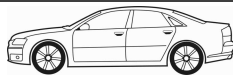

Article Nr.

Fitting Position

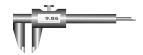

<b>MEGANE Scenic (JA0/1_)</b>		<b>10/1996 → 10/1999</b>	
Alternator Freewheel Clutch	1.6 16V		<b>F5-1029</b>
Alternator Freewheel Clutch	1.6 16V		<b>F5-1061</b>
Anti-Friction Bearing	1.4 i, 1.6 16V, 1.6 e, 1.6 i, 1.9 D, 1.9 dT, 1.9 dTi, 2.0 i, 2.0 RXE 4x4		<b>F8-3033</b>
Engine Mounting	1.4 i, 1.6 e, 1.6 i		<b>F8-4109</b>
Engine Mounting	1.6 e, 1.6 i		<b>F8-4110</b>
Stabiliser Mounting	1.6 e	01/1997 →	<b>F8-5086</b>
Stabiliser Mounting	1.6 i		<b>F8-5086</b>
Engine Mounting	1.9 dTi, 2.0 i		<b>F8-5472</b>
Top Strut Mounting	1.4 i, 1.6 e, 1.6 i, 1.9 dT, 2.0 i		<b>F8-5473</b>
Top Strut Mounting	1.6 16V	; Type: JA0B	<b>F8-5473</b>
Top Strut Mounting	1.9 D, 1.9 dTi	06/1999 →;	<b>F8-5473</b>
Engine Mounting	1.6 16V		<b>F8-5476</b>
Engine Mounting	1.4 i		<b>F8-5482</b>
Engine Mounting	1.6 e	01/1997 →;	<b>F8-5482</b>
Engine Mounting	1.6 i		<b>F8-5482</b>
Mounting, automatic transmission	1.6 16V	Type: JA0B	<b>F8-5485</b>
Mounting, automatic transmission	1.6 e		<b>F8-5485</b>
Mounting, automatic transmission	1.9 dT, 2.0 i		<b>F8-5485</b>
Mounting, automatic transmission	1.9 dTi	06/1999 →	<b>F8-5485</b>
Engine Mounting	1.9 D, 1.9 dT, 1.9 dTi		<b>F8-5490</b>
Belt Pulley, crankshaft	1.9 D, 1.9 dT		<b>F8-5645</b>
Belt Pulley, crankshaft	1.9 dTi	F9Q 734	<b>F8-5656</b>
Mounting, axle beam	1.4 i, 1.6 16V, 1.6 e, 1.6 i, 1.9 D, 1.9 dT, 1.9 dTi, 2.0 i, 2.0 RXE 4x4		<b>F8-6079</b>
Top Strut Mounting	1.4 i, 1.6 e, 1.6 i, 1.9 D, 1.9 dT, 1.9 dTi, 2.0 i, 2.0 RXE 4x4		<b>F8-6379</b>
Top Strut Mounting	1.6 16V		<b>F8-6379</b>
Engine Mounting	1.6 16V	K4M 700, K4M 701; Aluminium;	<b>F8-6482</b>
Engine Mounting	1.9 D, 1.9 dTi	06/1999 →	<b>F8-6483</b>
Engine Mounting	1.9 dT, 2.0 i		<b>F8-6483</b>
Stabiliser Mounting	1.9 D, 1.9 dT, 1.9 dTi, 2.0 i		<b>F8-6786</b>
Stabiliser Mounting	1.4 i, 1.6 e, 1.6 i, 1.9 D, 1.9 dT, 1.9 dTi, 2.0 i		<b>F8-6796</b>
Mounting, axle bracket	1.4 i, 1.6 e, 1.6 i, 2.0 i		<b>F8-7045</b>

<b>F5-1029</b>	<b>F5-1061</b>	<b>F8-3033</b>	<b>F8-4109</b>	<b>F8-4110</b>	<b>F8-5086</b>	<b>F8-5472</b>
Ref.Nr.: 7700110616	Ref.Nr.: 7700110616	Ref.Nr.: 7700797666	Ref.Nr.: 7700785949	Ref.Nr.: 7700805733	Ref.Nr.: 7700785929	Ref.Nr.: 7700832262
<b>F8-5473</b>	<b>F8-5476</b>	<b>F8-5482</b>	<b>F8-5485</b>	<b>F8-5490</b>	<b>F8-5645</b>	<b>F8-5656</b>
Ref.Nr.: 7700780875	Ref.Nr.: 7700832264	Ref.Nr.: 7700794601	Ref.Nr.: 7700788318	Ref.Nr.: 7700413614	Ref.Nr.: 7700724249	Ref.Nr.: 7700115309
<b>F8-6079</b>	<b>F8-6379</b>	<b>F8-6482</b>	<b>F8-6483</b>	<b>F8-6786</b>	<b>F8-6796</b>	<b>F8-7045</b>
Ref.Nr.: 95FB-5C485-AA	Ref.Nr.: 7700797654	Ref.Nr.: 82 00 148 388	Ref.Nr.: 77 00 832 256	Ref.Nr.: 7700847383	Ref.Nr.: 7700784170	Ref.Nr.: 770079772

Article Description

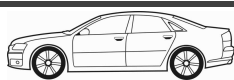

Article Nr.

Fitting Position



**MEGANE Scenic (JA0/1\_)** 10/1996 → 10/1999

Mounting, axle bracket	1.6 16V	Type: JA04	<b>F8-7045</b>		
Mounting, axle bracket	1.9 D	06/1999 →	<b>F8-7045</b>		
Mounting, axle bracket	1.9 dT	Type: JA0K, JA0Y	<b>F8-7045</b>		
Belt Pulley, crankshaft	1.6 16V	Number of Ribs: 6	<b>F8-7094</b>		Belt Pulley Ø [mm]=134; Mounting points diam.[mm]=26; W=33
Bearing, drive shaft	1.4 i, 1.6 16V, 1.6 e, 1.6 i, 1.9 dT, 2.0 i		<b>F8-7173</b>		d=25.8
Belt Pulley, crankshaft	2.0 i		<b>F8-7654</b>		
Stabiliser Mounting	1.4 i, 1.6 16V, 1.6 e, 1.6 i, 1.9 D, 1.9 dT, 1.9 dTi, 2.0 i		<b>F8-7905</b>	⊕ ⊕	d=24,5
Stabiliser Mounting	1.4 i, 1.6 e, 1.6 i, 1.9 D, 1.9 dT, 1.9 dTi, 2.0 i		<b>F8-7942</b>	⊕ ⊕	
Engine Mounting	1.6 16V, 1.9 D, 1.9 dT, 1.9 dTi, 2.0 i, 2.0 RXE 4x4		<b>F8-8146</b>	⊕	
Bellow, steering	1.4 i, 1.6 e, 1.6 i, 1.9 D, 1.9 dT, 1.9 dTi, 2.0 i	for steering gear ID: SMI; with clamps;	<b>LM-10000S</b>	⊕ ⊕ ⊕	d1=9; d2=39; L [mm]=168
Bellow, steering	1.4 i, 1.6 e, 1.6 i, 1.9 D, 1.9 dT, 1.9 dTi, 2.0 i	Manufacturer Restriction: TRW; with clamps;	<b>LM-10009S</b>	⊕ ⊕ ⊕	d1=12; d2=40; L [mm]=170
Bellow Set, drive shaft	1.4 i, 1.6 16V, 1.6 e, 1.6 i		<b>M-850850</b>	⊕ ⊕ ⊕	H=120; d1=28; d2=75.5
Bellow Set, drive shaft	1.4 i, 1.6 16V, 1.6 e, 1.6 i	ABS;	<b>MK-850850</b>	⊕ ⊕ ⊕	

**MODUS / GRAND MODUS (F/JPO\_)** 09/2004 →

Dust Cover Kit, shock absorber	1.2, 1.2 16V, 1.4, 1.5 dCi, 1.6		<b>AK-735258</b>	⊕ ⊕ ⊕	
Alternator Freewheel Clutch	1.5 dCi, 1.5 dCi 90		<b>F5-1095</b>		
Alternator Freewheel Clutch	1.4, 1.5 dCi, 1.5 dCi 75, 1.5 dCi 90, 1.6		<b>F5-1122</b>		
Belt Pulley, crankshaft	1.5 dCi	04/2005 →	<b>F8-5657</b>		
Belt Pulley, crankshaft	1.5 dCi	08/2006 →	<b>F8-5657</b>		
Belt Pulley, crankshaft	1.5 dCi	08/2006 →,  K9K 760, K9K 766	<b>F8-5657</b>		
Belt Pulley, crankshaft	1.5 dCi	08/2006 →,  K9K 762, K9K 768	<b>F8-5657</b>		
Top Strut Mounting	1.2	Type: FP0C, FP0K	<b>F8-6338</b>	⊕	
Top Strut Mounting	1.2	Type: FP0C, FP0K, JP0C, JP0K, JP0T	<b>F8-6338</b>	⊕	
Top Strut Mounting	1.2, 1.2 16V, 1.2 16V Hi-Flex, 1.5 dCi		<b>F8-6338</b>	⊕	
Top Strut Mounting	1.4	Type: JP01, JP0J	<b>F8-6338</b>	⊕	
Top Strut Mounting	1.5 dCi	Type: FP0G, JP0G, JP0H	<b>F8-6338</b>	⊕	
Top Strut Mounting	1.5 dCi	Type: JP0F, JP0H	<b>F8-6338</b>	⊕	
Top Strut Mounting	1.5 dCi	Type: JP0G, JP0H	<b>F8-6338</b>	⊕	
Top Strut Mounting	1.6	Type: JP0B, JP0U	<b>F8-6338</b>	⊕	
Top Strut Mounting	1.6	Type: JP0L, JP0V	<b>F8-6338</b>	⊕	
Engine Mounting	1.2 16V, 1.4, 1.5 dCi, 1.6		<b>F8-6522</b>		L=265

<b>AK-735258</b>	<b>F5-1095</b>	<b>F5-1122</b>	<b>F8-5657</b>	<b>F8-6338</b>	<b>F8-6522</b>	<b>F8-6523</b>
Ref.Nr.: 8200127285	Ref.Nr.: 8200113636	Ref.Nr.:	Ref.Nr.: 8200185800	Ref.Nr.: 54325-AX000	Ref.Nr.: 8200338385	Ref.Nr.: 54500-BC42A
<b>F8-7045</b>	<b>F8-7094</b>	<b>F8-7173</b>	<b>F8-7654</b>	<b>F8-7905</b>	<b>F8-7942</b>	<b>F8-8146</b>
Ref.Nr.: 7700779772	Ref.Nr.: 8200392683	Ref.Nr.: 7664079	Ref.Nr.: 7700109260	Ref.Nr.: 82 00 150 759	Ref.Nr.: 7700784171	Ref.Nr.: 7700425757
<b>LM-10000S</b>	<b>LM-10009S</b>	<b>M-850850</b>	<b>MK-850850</b>			
Ref.Nr.: 6000025546	Ref.Nr.: 7701469486	Ref.Nr.: 329373	Ref.Nr.: 329373			

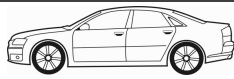

**Article Description****Article Nr.****Fitting Position**

<b>MODUS / GRAND MODUS (F/JP0_)</b>				<b>09/2004 →</b>	
Control Arm-/Trailing Arm Bush	1.2, 1.2 16V, 1.2 16V Hi-Flex, 1.4, 1.5 dCi, 1.6		<b>F8-6523</b>		d=12; D=40; Thick. [mm]=55
Top Strut Mounting	1.2, 1.2 16V, 1.2 16V Hi-Flex, 1.4, 1.5 dCi, 1.6		<b>F8-6525</b>		
Top Strut Mounting	1.2, 1.2 16V, 1.2 16V Hi-Flex, 1.4, 1.5 dCi, 1.6		<b>F8-6526</b>		
Control Arm-/Trailing Arm Bush	1.2, 1.2 16V, 1.2 16V Hi-Flex, 1.4, 1.5 dCi, 1.6		<b>F8-6662</b>		H=53; d=12; D=58
Engine Mounting	1.2, 1.4, 1.5 dCi, 1.6		<b>F8-6664</b>		
Engine Mounting	1.2, 1.4, 1.5 dCi, 1.6		<b>F8-6665</b>		
Engine Mounting	1.2, 1.2 16V Hi-Flex		<b>F8-6680</b>		L=185
Engine Mounting	1.5 dCi		<b>F8-6683</b>		
Top Strut Mounting	1.2	; Type: FP0C, FP0K	<b>F8-7057</b>		
Top Strut Mounting	1.2	; Type: FP0C, FP0K, JP0C, JP0K, JP0T	<b>F8-7057</b>		
Top Strut Mounting	1.4	; Type: JP01, JP0J	<b>F8-7057</b>		
Top Strut Mounting	1.5 dCi	; Type: FP0G, JP0G, JP0H	<b>F8-7057</b>		
Top Strut Mounting	1.5 dCi	; Type: JP0F, JP0H	<b>F8-7057</b>		
Top Strut Mounting	1.5 dCi	; Type: JP0G, JP0H	<b>F8-7057</b>		
Top Strut Mounting	1.6	; Type: JP0B, JP0U	<b>F8-7057</b>		
Top Strut Mounting	1.6	; Type: JP0L, JP0V	<b>F8-7057</b>		
Anti-Friction Bearing	1.2, 1.2 16V, 1.2 16V Hi-Flex, 1.4, 1.5 dCi, 1.6		<b>F8-7152</b>		
<b>EXTRA Van (F40_ , G40_)</b>				<b>07/1985 → 11/1998</b>	
Anti-Friction Bearing	1.0, 1.1, 1.2, 1.4, 1.4 RN, 1.6 D, 1.9 D		<b>F8-3033</b>		H=20; d1=62; d2=64; D=100
Engine Mounting	1.4, 1.9 D		<b>F8-5349</b>		
Engine Mounting	1.4	Type: F40U, F40V	<b>F8-5480</b>		
Engine Mounting	1.9 D	09/1993 →; Type: F40N	<b>F8-5480</b>		
Engine Mounting	1.2, 1.4		<b>F8-5484</b>		Outer Thread [mm]=M10
Top Strut Mounting	1.0, 1.1, 1.2, 1.4, 1.4 RN, 1.6 D, 1.9 D		<b>F8-5500</b>		
Belt Pulley, crankshaft	1.9 D		<b>F8-5645</b>		
Top Strut Mounting	1.0, 1.1, 1.2, 1.4, 1.6 D, 1.9 D		<b>F8-6378</b>		
Engine Mounting	1.4	C3J 760	<b>F8-6495</b>		
Mounting, axle beam	All Models		<b>F8-6669</b>		H=35; d=48; D=77
Engine Mounting	1.0	Type: F400	<b>F8-6841</b>		
Engine Mounting	1.1	C1E 750	<b>F8-6841</b>		
Engine Mounting	1.1, 1.4		<b>F8-6841</b>		
Engine Mounting	1.6 D		<b>F8-6842</b>		
Engine Mounting	1.6 D		<b>F8-6843</b>		

<b>F8-3033</b>	<b>F8-5349</b>	<b>F8-5480</b>	<b>F8-5484</b>	<b>F8-5500</b>	<b>F8-5645</b>	<b>F8-6378</b>
Ref.Nr.: 7700797666	Ref.Nr.: 7700800522	Ref.Nr.: 7700805123	Ref.Nr.: 7700795688	Ref.Nr.: 6001009755	Ref.Nr.: 7700724249	Ref.Nr.: 6001009755
<b>F8-6495</b>	<b>F8-6523</b>	<b>F8-6525</b>	<b>F8-6526</b>	<b>F8-6662</b>	<b>F8-6664</b>	<b>F8-6665</b>
Ref.Nr.: 77 00 805 733	Ref.Nr.: 54500-BC42A	Ref.Nr.: 54320-AX600	Ref.Nr.: 8200504291	Ref.Nr.: 82 00 346 942	Ref.Nr.: 8200127324	Ref.Nr.: 8200127321
<b>F8-6669</b>	<b>F8-6680</b>	<b>F8-6683</b>	<b>F8-6841</b>	<b>F8-6842</b>	<b>F8-6843</b>	<b>F8-6844</b>
Ref.Nr.: 7700809945	Ref.Nr.: 8200042453	Ref.Nr.: 8200399188	Ref.Nr.: 7700760488	Ref.Nr.: 7700770307	Ref.Nr.: 7700770479	Ref.Nr.: 7700770480

Article Description



Article Nr.

Fitting Position



**EXTRA Van (F40, G40)** 07/1985 → 11/1998

Engine Mounting	1.6 D		<b>F8-6844</b>	⊕	
Engine Mounting	1.6 D		<b>F8-6845</b>		
Engine Mounting	1.0	Type: F400	<b>F8-6864</b>	⊕	
Engine Mounting	1.1	C1E 750	<b>F8-6864</b>	⊕	
Engine Mounting	1.1, 1.4		<b>F8-6864</b>	⊕	
Engine Mounting	1.4	C3J 700	<b>F8-6864</b>	⊕	
Engine Mounting	1.9 D		<b>F8-6873</b>	⊕	
Engine Mounting	1.1, 1.4		<b>F8-6913</b>	⊕	
Bearing, drive shaft	1.2, 1.4, 1.6 D, 1.9 D		<b>F8-7173</b>		d=25.8
Control Arm-/Trailing Arm Bush	1.0, 1.1, 1.2, 1.4, 1.6 D, 1.9 D		<b>G9-570</b>	⊕ ⊕ ⊕ ↓	H1=35; H2=46; d=12; D=32
Bellow Set, drive shaft	1.0, 1.1, 1.2, 1.4, 1.6 D, 1.9 D		<b>M-850850</b>	⊕ ⊕ ⊕	H=120; d1=28; d2=75.5
Bellow Set, drive shaft	1.0, 1.1, 1.2, 1.4, 1.6 D, 1.9 D		<b>MK-850850</b>	⊕ ⊕ ⊕	

**SAFRANE (B54)** 04/1992 → 07/1996

Dust Cover Kit, shock absorber	2.0, 2.0 12V, 2.1 dT, 2.2, 2.5 dT, 3.0 V6		<b>AK-735042</b>	⊕ ⊕ ⊕	
Dust Cover Kit, shock absorber	2.0, 2.0 12V, 2.1 dT, 2.2, 2.5 dT, 3.0 Biturbo 4x4, 3.0 V6, 3.0 V6 4x4		<b>AK-735261</b>	⊕ ⊕ ⊕	
Anti-Friction Bearing	All Models		<b>F8-3012</b>	⊕ ⊕ ⊕	H=20; d=66; D=100
Anti-Friction Bearing	2.0, 2.0 12V		<b>F8-3033</b>	⊕ ⊕ ⊕	H=20; d1=62; d2=64; D=100
Top Strut Mounting	2.0, 2.0 12V, 2.1 dT, 2.2, 2.5 dT, 3.0 Biturbo 4x4, 3.0 V6, 3.0 V6 4x4		<b>F8-5620</b>	⊕ ⊕ ⊕	
Control Arm-/Trailing Arm Bush	2.0 12V, 2.1 dT, 2.2, 2.5 dT, 3.0 Biturbo 4x4, 3.0 V6, 3.0 V6 4x4		<b>G9-676</b>	⊕ ⊕ ⊕ ↓	H1=31; H2=49; d=18; D1=29; D2=55
Control Arm-/Trailing Arm Bush	2.0 12V, 2.1 dT, 2.2, 2.5 dT, 3.0 Biturbo 4x4, 3.0 V6, 3.0 V6 4x4		<b>G9-677</b>	⊕ ⊕ ⊕ ↓	H=50; d=12; D=59

**SAFRANE Mk II (B54)** 07/1996 → 12/2000

Dust Cover Kit, shock absorber	All Models		<b>AK-735042</b>	⊕ ⊕ ⊕	
Dust Cover Kit, shock absorber	All Models		<b>AK-735261</b>	⊕ ⊕ ⊕	
Anti-Friction Bearing	All Models		<b>F8-3012</b>	⊕ ⊕ ⊕	H=20; d=66; D=100
Anti-Friction Bearing	2.9 24V, 3.0 V6		<b>F8-3033</b>	⊕ ⊕ ⊕	H=20; d1=62; d2=64; D=100
Top Strut Mounting	2.0 16V, 2.2 dT, 2.5 20V		<b>F8-5620</b>	⊕ ⊕ ⊕	
Belt Pulley, crankshaft	2.2 dT		<b>F8-5648</b>		
Engine Mounting	2.0 16V, 2.2 dT, 2.5 20V		<b>F8-6862</b>	⊕	
Engine Mounting	2.0 16V, 2.2 dT, 2.5 20V		<b>F8-6878</b>	⊕ ↑	
Engine Mounting	2.9 24V	Type: B54N	<b>F8-6878</b>	⊕ ↑	
Control Arm-/Trailing Arm Bush	All Models		<b>G9-676</b>	⊕ ⊕ ⊕ ↓	H1=31; H2=49; d=18; D1=29; D2=55

<b>AK-735042</b>	<b>AK-735261</b>	<b>F8-3012</b>	<b>F8-3033</b>	<b>F8-5620</b>	<b>F8-5648</b>	<b>F8-6844</b>
Ref.Nr.: 7700776743	Ref.Nr.:	Ref.Nr.: 503527	Ref.Nr.: 7700797666	Ref.Nr.: 7700805922	Ref.Nr.: 7700104292	Ref.Nr.: 7700770480
<b>F8-6845</b>	<b>F8-6862</b>	<b>F8-6864</b>	<b>F8-6873</b>	<b>F8-6878</b>	<b>F8-6913</b>	<b>F8-7173</b>
Ref.Nr.: 7700771949	Ref.Nr.: 7700841531	Ref.Nr.: 7700762721	Ref.Nr.: 7700818994	Ref.Nr.: 7700833302	Ref.Nr.: 7700755531	Ref.Nr.: 7664079
<b>G9-570</b>	<b>G9-676</b>	<b>G9-677</b>	<b>M-850850</b>	<b>MK-850850</b>		
Ref.Nr.: 7700762574	Ref.Nr.: 7700806239	Ref.Nr.: 7700806238	Ref.Nr.: 329373	Ref.Nr.: 329373		

**Article Description****Article Nr.****Fitting Position**

<b>SAFRANE Mk II (B54_)</b>			<b>07/1996 → 12/2000</b>		
Control Arm-/Trailing Arm Bush	All Models		<b>G9-677</b>		H=50; d=12; D=59
<b>SANDERO/STEPWAY I</b>			<b>12/2007 →</b>		
Alternator Freewheel Clutch	1.4, 1.6		<b>F5-1061</b>		
Anti-Friction Bearing	1.4, 1.6		<b>F8-3032</b>		H=9; d1=16; d2=27; D=56
Top Strut Mounting	1.4, 1.6		<b>F8-6596</b>		
Engine Mounting	1.4, 1.6		<b>F8-6711</b>		
Rubber Buffer, suspension	All Models		<b>F8-7900</b>		
Control Arm-/Trailing Arm Bush	1.4, 1.6		<b>F8-7977</b>		
<b>SCÉNIC I (JA0/1_)</b>			<b>09/1999 → 09/2003</b>		
Alternator Freewheel Clutch	1.9 dCi , 1.9 dCi RX4, 1.9 dTi		<b>F5-1014</b>		
Alternator Freewheel Clutch	1.4 16V		<b>F5-1029</b>		
Alternator Freewheel Clutch	1.4 16V , 1.6, 1.6 BiFuel		<b>F5-1061</b>		
Anti-Friction Bearing	1.4 16V , 1.9 D, 1.9 dTi , 2.0 16V		<b>F8-3033</b>		H=20; d1=62; d2=64; D=100
Engine Mounting	1.9 dTi		<b>F8-5472</b>		
Top Strut Mounting	1.4 16V	; Type: JA0D, JA0W	<b>F8-5473</b>		
Top Strut Mounting	1.9 dTi , 2.0 16V		<b>F8-5473</b>		
Engine Mounting	1.4 16V	K4J 714;	<b>F8-5476</b>		
Mounting, automatic transmission	1.9 dTi , 2.0 16V		<b>F8-5485</b>		
Belt Pulley, crankshaft	1.9 dCi , 1.9 dCi RX4, 1.9 dTi		<b>F8-5656</b>		
Mounting, axle beam	1.4 16V , 1.8 16V , 1.8 4x4, 1.9 dCi , 1.9 dTi , 2.0 16V		<b>F8-6079</b>		H1=73; H2=37; d=32; D1=72; D2=40
Mounting, axle beam	1.6	K4M 709	<b>F8-6079</b>		H1=73; H2=37; d=32; D1=72; D2=40
Gear, camshaft	1.9 dTi	11/2001 →;  F9Q 731, F9Q 736; Engine Management: Timing Belt;  40	<b>F8-6254</b>		d=13; D=120; W=30
Gear, camshaft	1.9 dTi	Engine Management: Timing Belt;  40	<b>F8-6254</b>		d=13; D=120; W=30
Top Strut Mounting	1.4 16V , 1.8 16V , 1.9 dCi , 1.9 dTi , 2.0 16V		<b>F8-6379</b>		
Top Strut Mounting	1.6, 1.9 dCi RX4		<b>F8-6379</b>		
Engine Mounting	1.8 16V	F4P 722; Aluminium	<b>F8-6482</b>		
Engine Mounting	1.8 4x4, 1.9 dTi , 2.0 16V	Aluminium	<b>F8-6482</b>		
Engine Mounting	1.9 dCi	F9Q 732; Aluminium;	<b>F8-6482</b>		
Engine Mounting	1.9 dCi RX4	Aluminium;	<b>F8-6482</b>		
Engine Mounting	1.9 dCi , 1.9 dTi		<b>F8-6483</b>		
Mounting, axle bracket	1.4 16V	Type: JA0W	<b>F8-7045</b>		

<b>F5-1014</b>	<b>F5-1029</b>	<b>F5-1061</b>	<b>F8-3032</b>	<b>F8-3033</b>	<b>F8-5472</b>	<b>F8-5473</b>
Ref.Nr.: 8641982	Ref.Nr.: 7700110616	Ref.Nr.: 7700110616	Ref.Nr.: 8200651172	Ref.Nr.: 7700797666	Ref.Nr.: 7700832262	Ref.Nr.: 7700780875
<b>F8-5476</b>	<b>F8-5485</b>	<b>F8-5656</b>	<b>F8-6079</b>	<b>F8-6254</b>	<b>F8-6379</b>	<b>F8-6482</b>
Ref.Nr.: 7700832264	Ref.Nr.: 7700788318	Ref.Nr.: 7700115309	Ref.Nr.: 95FB-5C485-AA	Ref.Nr.: 8200125710	Ref.Nr.: 7700797654	Ref.Nr.: 82 00 148 388
<b>F8-6483</b>	<b>F8-6596</b>	<b>F8-6711</b>	<b>F8-7045</b>	<b>F8-7900</b>	<b>F8-7977</b>	<b>G9-677</b>
Ref.Nr.: 77 00 832 256	Ref.Nr.: 6001547499	Ref.Nr.: 112107695R	Ref.Nr.: 7700779772	Ref.Nr.: 6001548402	Ref.Nr.: 6040002245	Ref.Nr.: 7700806238

Article Description			Article Nr.	Fitting Position	
---------------------	--	--	-------------	------------------	--

**SCÉNIC I (JA0/1\_)** 09/1999 → 09/2003

Mounting, axle bracket	1.9 dTi, 2.0 16V		F8-7045		
Belt Pulley, crankshaft	1.4 16V	Number of Ribs: 6	F8-7094		Belt Pulley Ø [mm]=134; Mounting points diam.[mm]=26; W=33
Bearing, drive shaft	1.4 16V		F8-7173		d=25.8
Stabiliser Mounting	1.4 16V, 1.9 dCi RX4, 1.9 dTi, 2.0 16V RX4		F8-7905		d=24,5
Stabiliser Mounting	2.0 16V RX4		F8-7942		
Engine Mounting	1.4 16V, 1.6, 1.8 16V, 1.8 4x4, 1.9 dCi, 1.9 dCi RX4, 1.9 dTi, 2.0 16V, 2.0 16V RX4		F8-8146		
Control Arm-/Trailing Arm Bush	2.0 16V		G9-653		H1=35; H2=46; d=12; D=45
Bellow Set, drive shaft	1.4 16V		M-850850		H=120; d1=28; d2=75.5
Bellow Set, drive shaft	1.4 16V	ABS;	MK-850850		

**SCÉNIC II (JM0/1\_)** 06/2003 →

Dust Cover Kit, shock absorber	1.4, 1.5 dCi, 1.6, 1.9 dCi, 2.0, 2.0 16V Turbo		AK-735061		
Dust Cover Kit, shock absorber	1.9 dCi	F9Q 803, F9Q 804;	AK-735061		
Alternator Freewheel Clutch	1.4	K4J 740	F5-1061		
Alternator Freewheel Clutch	1.5 dCi, 1.6, 1.6 16V		F5-1061		
Alternator Freewheel Clutch	1.4	K4J 730, K4J 740	F5-1062		
Alternator Freewheel Clutch	1.6		F5-1062		
Alternator Freewheel Clutch	1.6 16V	K4M 812, K4M 813	F5-1062		
Alternator Freewheel Clutch	2.0 dCi		F5-1063		
Alternator Freewheel Clutch	1.4, 1.5 dCi, 1.6, 1.6 16V		F5-1122		
Alternator Freewheel Clutch	1.5 dCi		F5-1130		
Belt Pulley, crankshaft	1.5 dCi		F8-5657		
Belt Pulley, crankshaft	1.5 dCi	06/2006 →,  K9K 722, K9K 724	F8-5657		
Top Strut Mounting	1.4, 1.5 dCi, 1.6, 1.6 16V, 1.9 D, 1.9 dCi, 2.0, 2.0 16V Turbo, 2.0 dCi		F8-6175		
Top Strut Mounting	1.4, 1.5 dCi, 1.6, 1.6 16V, 1.9 D, 1.9 dCi, 2.0, 2.0 16V Turbo, 2.0 dCi		F8-6195		
Anti-Friction Bearing	1.4, 1.5 dCi, 1.6, 1.6 16V, 1.9 D, 1.9 dCi, 2.0, 2.0 16V Turbo, 2.0 dCi		F8-6335		
Engine Mounting	1.9 D, 1.9 dCi, 2.0, 2.0 16V Turbo		F8-6420		
Engine Mounting	1.5 dCi		F8-6522		L=265
Engine Mounting	1.9 dCi, 2.0		F8-6676		
Engine Mounting	1.5 dCi, 2.0 dCi		F8-6678		
Mounting, axle beam	1.4, 1.5 dCi, 1.6, 1.6 16V, 1.9 D, 1.9 dCi, 2.0, 2.0 16V Turbo, 2.0 dCi		F8-6679		d=12; D=70

<b>AK-735061</b>	<b>F5-1061</b>	<b>F5-1062</b>	<b>F5-1063</b>	<b>F5-1122</b>	<b>F5-1130</b>	<b>F8-5657</b>
Ref.Nr.: 8200040073	Ref.Nr.: 7700110616	Ref.Nr.: 7701476465	Ref.Nr.:	Ref.Nr.:	Ref.Nr.: 23151-3VD1A	Ref.Nr.: 8200185800
<b>F8-6175</b>	<b>F8-6195</b>	<b>F8-6335</b>	<b>F8-6420</b>	<b>F8-6522</b>	<b>F8-6676</b>	<b>F8-6678</b>
Ref.Nr.: 8200222463	Ref.Nr.: 7701207678	Ref.Nr.: 7701208891	Ref.Nr.: 8200338381	Ref.Nr.: 8200338385	Ref.Nr.: 11350-BV000	Ref.Nr.: 8200355673
<b>F8-6679</b>	<b>F8-6680</b>	<b>F8-7045</b>	<b>F8-7094</b>	<b>F8-7173</b>	<b>F8-7905</b>	<b>F8-7942</b>
Ref.Nr.: 8200038243	Ref.Nr.: 8200042453	Ref.Nr.: 7700779772	Ref.Nr.: 8200392683	Ref.Nr.: 7664079	Ref.Nr.: 82 00 150 759	Ref.Nr.: 7700784171

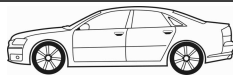
**Article Description****Article Nr.****Fitting Position**

<b>SCÉNIC II (JM0/1_)</b>			<b>06/2003 →</b>		
Engine Mounting	1.5 dCi, 1.9 D, 1.9 dCi, 2.0, 2.0 16V Turbo		<b>F8-6680</b>		L=185
Holder, engine mounting	1.4, 1.5 dCi, 1.6, 1.9 dCi, 2.0		<b>F8-6681</b>		
Holder, engine mounting	1.5 dCi, 1.6, 1.9 dCi, 2.0		<b>F8-6682</b>		
Belt Pulley, crankshaft	1.9 D, 1.9 dCi	Number of Ribs: 7	<b>F8-7093</b>		Belt Pulley Ø [mm]=155; Mounting points diam.[mm]=25; W=41
Belt Pulley, crankshaft	1.9 D, 1.9 dCi		<b>F8-7093S1</b>		
Belt Pulley, crankshaft	2.0 dCi	Number of Ribs: 6; Parameter: 7PK	<b>F8-7657</b>		
Engine Mounting	1.5 dCi		<b>F8-7746</b>		
Control Arm-Trailing Arm Bush	1.4, 1.5 dCi, 1.6, 1.6 16V, 1.9 D, 1.9 dCi, 2.0, 2.0 16V Turbo, 2.0 dCi		<b>F8-7989</b>		d=12; D=24, 58; Thick. [mm]=53
Control Arm-Trailing Arm Bush	1.4, 1.5 dCi, 1.6, 1.6 16V, 1.9 D, 1.9 dCi, 2.0, 2.0 16V Turbo, 2.0 dCi		<b>F8-7992</b>		d=12; D=33, 43; Thick. [mm]=48
Engine Mounting	1.9 dCi		<b>F8-8162</b>		
Engine Mounting	1.4, 1.6		<b>F8-8168</b>		
<b>SCÉNIC III (JZ0/1_)</b>			<b>02/2009 →</b>		
Alternator Freewheel Clutch	2.0 16V		<b>F5-1025</b>		
Alternator Freewheel Clutch	1.5 dCi		<b>F5-1061</b>		
Alternator Freewheel Clutch	1.9 dCi		<b>F5-1063</b>		
Alternator Freewheel Clutch	1.2 TCe, 1.6 dCi, 1.9 dCi		<b>F5-1110</b>		
Alternator Freewheel Clutch	1.5 dCi, 1.6 16V, 1.6 E85		<b>F5-1122</b>		
Alternator Freewheel Clutch	1.2 TCe, 1.4 16V, 1.6 dCi, 2.0 dCi		<b>F5-1129</b>		
Anti-Friction Bearing	1.4 16V, 1.5 dCi, 1.6 E85, 1.9 dCi, 2.0 dCi		<b>F8-7637</b>		H=34; d=99; D1=140; D2=108
<b>SUPER 5 (B/C40_)</b>			<b>10/1984 → 12/1996</b>		
Anti-Friction Bearing	1.0, 1.1, 1.2, 1.4, 1.4 Turbo, 1.4 Turbo GT, 1.6 D, 1.7, 1.7 i		<b>F8-3033</b>		H=20; d1=62; d2=64; D=100
Stabiliser Mounting	1.0, 1.1, 1.4, 1.6 D, 1.7		<b>F8-5098</b>		d=23
Top Strut Mounting	1.0, 1.1, 1.2, 1.4, 1.4 Turbo, 1.6 D, 1.7, 1.7 i		<b>F8-5500</b>		
Repair Kit, wheel suspension	1.0, 1.1, 1.4, 1.6 D, 1.7	01/1987 →	<b>F8-6278</b>		
Repair Kit, wheel suspension	1.2, 1.4, 1.7		<b>F8-6278</b>		
Repair Kit, wheel suspension	1.4	01/1987 →; not for equipment variant: 566, 567	<b>F8-6278</b>		
Top Strut Mounting	1.0, 1.1, 1.2, 1.4, 1.4 Turbo, 1.4 Turbo GT, 1.6 D, 1.7, 1.7 i		<b>F8-6378</b>		
Stabiliser Mounting	1.0, 1.1, 1.2, 1.4, 1.4 Turbo, 1.4 Turbo GT, 1.6 D, 1.7, 1.7 i		<b>F8-6789</b>		
Stabiliser Mounting	1.0, 1.1, 1.2, 1.4, 1.4 Turbo, 1.4 Turbo GT, 1.6 D, 1.7, 1.7 i		<b>F8-6798</b>		d=23

<b>F5-1025</b>	<b>F5-1061</b>	<b>F5-1063</b>	<b>F5-1110</b>	<b>F5-1122</b>	<b>F5-1129</b>	<b>F8-3033</b>
Ref.Nr.: 23151-00Q0B	Ref.Nr.: 7700110616	Ref.Nr.:	Ref.Nr.: 8200489514	Ref.Nr.:	Ref.Nr.: 23151-JG71B	Ref.Nr.: 7700797666
<b>F8-5098</b>	<b>F8-5500</b>	<b>F8-6278</b>	<b>F8-6378</b>	<b>F8-6680</b>	<b>F8-6681</b>	<b>F8-6682</b>
Ref.Nr.: 7700760265	Ref.Nr.: 6001009755	Ref.Nr.: 7701464320	Ref.Nr.: 6001009755	Ref.Nr.: 8200042453	Ref.Nr.: 8200197453	Ref.Nr.: 8200197452
<b>F8-6789</b>	<b>F8-6798</b>	<b>F8-6841</b>	<b>F8-7093</b>	<b>F8-7093S1</b>	<b>F8-7637</b>	<b>F8-7657</b>
Ref.Nr.: 7700763934	Ref.Nr.: 7700693154	Ref.Nr.: 7700760488	Ref.Nr.: 8200457775	Ref.Nr.: 12303AW300	Ref.Nr.: 543250005R	Ref.Nr.: 1230300Q0A

Article Description



Article Nr.

Fitting Position



<b>SUPER 5 (B/C40_)</b>			<b>10/1984 → 12/1996</b>		
Engine Mounting	1.0, 1.1, 1.2, 1.4, 1.4 Turbo, 1.4 Turbo GT, 1.7, 1.7 i		<b>F8-6841</b>	↓	
Engine Mounting	1.0, 1.1, 1.2, 1.4, 1.4 Turbo, 1.4 Turbo GT, 1.7, 1.7 i		<b>F8-6841</b>		
Engine Mounting	1.1	07/1987 →; Type: B40H, C40H	<b>F8-6841</b>		
Engine Mounting	1.4	07/1989 →	<b>F8-6841</b>		
Engine Mounting	1.7	Type: B40G, B40K, C40G, C40K	<b>F8-6841</b>		
Engine Mounting	1.6 D		<b>F8-6842</b>	↕	
Engine Mounting	1.6 D		<b>F8-6843</b>	↕	
Engine Mounting	1.6 D		<b>F8-6844</b>	↕	
Engine Mounting	1.6 D		<b>F8-6845</b>		
Engine Mounting	1.0, 1.1, 1.2, 1.4, 1.4 Turbo, 1.7, 1.7 i		<b>F8-6864</b>	↕	
Engine Mounting	1.1	07/1987 →; Type: B40H, C40H	<b>F8-6864</b>	↕	
Engine Mounting	1.4	07/1989 →	<b>F8-6864</b>	↕	
Engine Mounting	1.7	Type: B40G, B40K, C40G, C40K	<b>F8-6864</b>	↕	
Engine Mounting	1.0, 1.1, 1.4, 1.4 Turbo, 1.7, 1.7 i		<b>F8-6913</b>	↕	
Bearing, drive shaft	1.0, 1.1, 1.4, 1.4 Turbo, 1.6 D, 1.7, 1.7 i		<b>F8-7173</b>		d=25.8
Control Arm-/Trailing Arm Bush	1.0, 1.1, 1.2, 1.4, 1.4 Turbo, 1.4 Turbo GT, 1.6 D, 1.7, 1.7 i		<b>G9-570</b>	↕	H1=35; H2=46; d=12; D=32
Bellow, steering	1.0, 1.1, 1.2, 1.4, 1.4 Turbo, 1.4 Turbo GT, 1.6 D, 1.7, 1.7 i	with clamps;	<b>LM-10001S</b>	↕	d1=10; d2=30; L [mm]=158
Bellow, steering	1.0, 1.1, 1.2, 1.4, 1.4 Turbo, 1.4 Turbo GT, 1.6 D, 1.7, 1.7 i	with clamps;	<b>LM-10002S</b>	↕	d1=10; d2=40; L [mm]=160
Bellow, steering	1.0, 1.1, 1.2, 1.4, 1.4 Turbo, 1.4 Turbo GT, 1.6 D, 1.7, 1.7 i	with clamps;	<b>LM-10042S</b>	↕	d1=10; d2=27.5; L [mm]=155
Bellow Set, drive shaft	1.0, 1.1, 1.2, 1.4, 1.4 Turbo, 1.6 D, 1.7, 1.7 i		<b>M-850850</b>	↕	H=120; d1=28; d2=75.5
Bellow Set, drive shaft	1.2, 1.4		<b>M-860860</b>	↕	H=80; d2=85; D1=25.8
Bellow Set, drive shaft	1.0, 1.1, 1.2, 1.4, 1.4 Turbo, 1.6 D, 1.7, 1.7 i		<b>MK-850850</b>	↕	
Bellow Set, drive shaft	1.0, 1.1, 1.4, 1.4 Turbo, 1.7, 1.7 i		<b>MK-860860</b>	↕	D1=25.8; D2113.5; L=88
<b>SUPER 5 Box (S40_)</b>			<b>10/1984 → 12/1996</b>		
Anti-Friction Bearing	1.0, 1.1, 1.2, 1.4, 1.6 D		<b>F8-3033</b>	↕	H=20; d1=62; d2=64; D=100
Top Strut Mounting	1.0, 1.1, 1.2, 1.6 D		<b>F8-5500</b>	↕	
Repair Kit, wheel suspension	1.0, 1.1, 1.6 D	01/1987 →	<b>F8-6278</b>	↕	
Repair Kit, wheel suspension	1.2		<b>F8-6278</b>	↕	
Top Strut Mounting	1.0, 1.1, 1.2, 1.6 D		<b>F8-6378</b>	↕	
Stabiliser Mounting	1.0, 1.1, 1.2, 1.6 D		<b>F8-6789</b>	↕	
Stabiliser Mounting	1.0, 1.1, 1.2, 1.6 D		<b>F8-6798</b>	↕	d=23

<b>F8-3033</b>	<b>F8-5500</b>	<b>F8-6278</b>	<b>F8-6378</b>	<b>F8-6789</b>	<b>F8-6798</b>	<b>F8-6841</b>
Ref.Nr.: 7700797666	Ref.Nr.: 6001009755	Ref.Nr.: 7701464320	Ref.Nr.: 6001009755	Ref.Nr.: 7700763934	Ref.Nr.: 7700693154	Ref.Nr.: 7700760488
<b>F8-6842</b>	<b>F8-6843</b>	<b>F8-6844</b>	<b>F8-6845</b>	<b>F8-6864</b>	<b>F8-6913</b>	<b>F8-7173</b>
Ref.Nr.: 7700770307	Ref.Nr.: 7700770479	Ref.Nr.: 7700770480	Ref.Nr.: 7700771949	Ref.Nr.: 7700762721	Ref.Nr.: 7700755531	Ref.Nr.: 7664079
<b>G9-570</b>	<b>LM-10001S</b>	<b>LM-10002S</b>	<b>LM-10042S</b>	<b>M-850850</b>	<b>M-860860</b>	<b>MK-850850</b>
Ref.Nr.: 7700762574	Ref.Nr.: 7700678649	Ref.Nr.: 7700706007	Ref.Nr.: 7701469497	Ref.Nr.: 329373	Ref.Nr.: 7701462308	Ref.Nr.: 329373

**Article Description****Article Nr.****Fitting Position**

<b>SUPER 5 Box (S40_)</b>		<b>10/1984 → 12/1996</b>	
Control Arm-/Trailing Arm Bush	1.0 , 1.1 , 1.2 , 1.6 D		G9-570
Bellow, steering	1.0 , 1.1 , 1.2 , 1.6 D	with clamps;	LM-10001S
Bellow, steering	1.0 , 1.1 , 1.2 , 1.6 D	with clamps;	LM-10002S
Bellow, steering	1.0 , 1.1 , 1.2 , 1.6 D	with clamps;	LM-10042S
Bellow Set, drive shaft	1.0 , 1.1 , 1.2 , 1.6 D		M-850850
Bellow Set, drive shaft	1.2		M-860860
Bellow Set, drive shaft	1.0 , 1.1 , 1.2 , 1.6 D		MK-850850
<b>THALIA I (LB0/1/2_)</b>		<b>02/1998 → 10/2003</b>	
Dust Cover Kit, shock absorber	1.2, 1.2 16V, 1.4, 1.4 16V, 1.5 dCi, 1.6, 1.6 16V, 2.0, 3.0 V6 Turbo Sport		AK-735257
Alternator Freewheel Clutch	1.4, 1.4 16V, 1.5 dCi		F5-1061
Alternator Freewheel Clutch	1.5 dCi		F5-1083
Alternator Freewheel Clutch	1.5 dCi		F5-1122
Anti-Friction Bearing	1.2 16V, 1.4, 1.4 16V, 1.5 dCi, 1.6, 1.6 16V, 1.9 D, 2.0		F8-3032
Stabiliser Set	1.6 16V		F8-5087
Engine Mounting	1.4, 1.4 16V		F8-5487
Spring Cap	1.2	D7F 744	F8-5488
Spring Cap	1.2 16V, 1.4, 1.4 16V, 1.5 dCi, 1.6, 1.6 16V, 1.9 D, 2.0, 3.0 V6 Turbo Sport		F8-5488
Top Strut Mounting	1.2, 1.2 16V, 1.4, 1.4 16V, 1.5 dCi, 1.6, 1.6 16V, 1.9 D, 2.0		F8-5496
Belt Pulley, crankshaft	1.9 D		F8-5645
Belt Pulley, crankshaft	1.5 dCi		F8-5657
Belt Pulley, crankshaft	1.5 dCi	09/2008 →	F8-5657
Belt Pulley, crankshaft	1.5 dCi	10/2003 →	F8-5657
Mounting, axle beam	1.2, 1.2 16V, 1.4, 1.4 16V, 1.5 dCi, 1.6, 1.6 16V, 1.9 D, 2.0, 3.0 V6 Turbo Sport		F8-6174
Top Strut Mounting	1.2 16V, 1.4, 1.4 16V, 1.5 dCi, 1.6, 1.6 16V, 1.9 D, 2.0		F8-6329
Belt Pulley, crankshaft	1.4 16V	01/2001 →; Number of Ribs: 6	F8-7094
Engine Mounting	1.5 dCi		F8-8172
<b>THALIA II (LU1/2_)</b>		<b>09/2008 →</b>	
Alternator Freewheel Clutch	1.5 dCi, 1.6 16V		F5-1061
Alternator Freewheel Clutch	1.5 dCi		F5-1083
Alternator Freewheel Clutch	1.5 dCi		F5-1122
Anti-Friction Bearing	1.5 dCi		F8-3032

<b>AK-735257</b>	<b>F5-1061</b>	<b>F5-1083</b>	<b>F5-1122</b>	<b>F8-3032</b>	<b>F8-5087</b>	<b>F8-5487</b>
Ref.Nr.: 7700802667	Ref.Nr.: 7700110616	Ref.Nr.:	Ref.Nr.:	Ref.Nr.: 8200651172	Ref.Nr.: 54616-00QAA	Ref.Nr.: 7700434370
<b>F8-5488</b>	<b>F8-5496</b>	<b>F8-5645</b>	<b>F8-5657</b>	<b>F8-6174</b>	<b>F8-6329</b>	<b>F8-7094</b>
Ref.Nr.: 7700828866	Ref.Nr.: 7700829529	Ref.Nr.: 7700724249	Ref.Nr.: 8200185800	Ref.Nr.: 7700429441	Ref.Nr.: 7700829529	Ref.Nr.: 8200392683
<b>F8-8172</b>	<b>G9-570</b>	<b>LM-10001S</b>	<b>LM-10002S</b>	<b>LM-10042S</b>	<b>M-850850</b>	<b>M-860860</b>
Ref.Nr.: 8200170362	Ref.Nr.: 7700762574	Ref.Nr.: 7700678649	Ref.Nr.: 7700706007	Ref.Nr.: 7701469497	Ref.Nr.: 329373	Ref.Nr.: 7701462308

Article Description

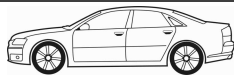

Article Nr.

Fitting Position



<b>THALIA II (LU1/2_)</b>			<b>09/2008 →</b>		
Top Strut Mounting	1.5 dCi		<b>F8-5496</b>		
Top Strut Mounting	1.5 dCi		<b>F8-6329</b>		
Engine Mounting	1.2 16V		<b>F8-8188</b>		
<b>TRAFIC Bus (T5, T6, T7)</b>			<b>03/1980 → 04/1989</b>		
Engine Mounting	1.6, 1.7, 2.0, 2.0 4x4, 2.1 D		<b>F8-5486</b>		
Stabiliser Mounting	1.4, 1.6, 1.6 4x4, 1.7, 2.0, 2.0 4x4, 2.1 D		<b>F8-5860</b>		d=20.5
Engine Mounting	1.6	Type: T551	<b>F8-6846</b>		
Engine Mounting	1.6, 1.7, 2.0		<b>F8-6866</b>		
Engine Mounting	2.0 4x4		<b>F8-6866</b>		
Engine Mounting	2.1 D	05/1985 →;	<b>F8-6866</b>		
<b>TRAFIC Van (T1, T3, T4)</b>			<b>03/1980 → 04/1989</b>		
Control Arm-/Trailing Arm Bush	2.0	J5R 726	<b>F8-5071</b>		d=18; L=58.5; D=36
Engine Mounting	1.4, 1.6, 1.6 4x4, 1.7, 2.0, 2.0 4x4, 2.1 D, 2.1 D 4x4		<b>F8-5486</b>		
Engine Mounting	1.6	Type: T311	<b>F8-6846</b>		
Engine Mounting	1.6, 1.7, 2.1 D		<b>F8-6866</b>		
Engine Mounting	2.0 4x4, 2.1 D 4x4		<b>F8-6866</b>		
<b>TRAFIC Platform/Chassis (P6)</b>			<b>03/1980 → 04/1989</b>		
Engine Mounting	1.4, 1.6, 1.7, 2.0, 2.1 D, 2.5 D		<b>F8-5486</b>		
Engine Mounting	1.6		<b>F8-6846</b>		
Engine Mounting	1.6, 2.0, 2.1 D		<b>F8-6866</b>		
<b>TRAFIC Bus (TXW)</b>			<b>05/1989 → 03/2001</b>		
Control Arm-/Trailing Arm Bush	2.1 D	J8S 758	<b>F8-5071</b>		d=18; L=58.5; D=36
Control Arm-/Trailing Arm Bush	2.2, 2.2 4x4		<b>F8-5071</b>		d=18; L=58.5; D=36
Control Arm-/Trailing Arm Bush	2.5 D, 2.5 D 4x4	S8U 758	<b>F8-5071</b>		d=18; L=58.5; D=36
Stabiliser Mounting	1.7, 1.9 D, 2.0, 2.1 D, 2.2, 2.2 4x4, 2.5 D, 2.5 D 4x4		<b>F8-5096</b>		d=25.5
Engine Mounting	1.7, 1.9 D, 2.0, 2.1 D, 2.2, 2.2 4x4, 2.5 D		<b>F8-5486</b>		
Control Arm-/Trailing Arm Bush	2.1 D, 2.2, 2.2 4x4, 2.5 D, 2.5 D 4x4		<b>F8-5805</b>		
Engine Mounting	1.9 D, 2.1 D, 2.2		<b>F8-6839</b>		
Engine Mounting	2.5 D	11/1996 →	<b>F8-6839</b>		
Engine Mounting	2.5 D 4x4	09/1994 →	<b>F8-6839</b>		
Engine Mounting	2.1 D, 2.5 D		<b>F8-6866</b>		





**Article Description****Article Nr.****Fitting Position**

<b>TRAFIC Bus (TXW)</b>				<b>05/1989 → 03/2001</b>	
Belt Pulley, crankshaft	2.1 D, 2.5 D	10/1994 →; Number of Ribs: 2	<b>F8-7091</b>		Belt Pulley Ø [mm]=142; Mounting points diam.[mm]=15; W=38
Belt Pulley, crankshaft	2.1 D		<b>F8-7093S1</b>		
Bellow, steering	1.7, 1.9 D, 2.0, 2.1 D, 2.2, 2.2 4x4, 2.5 D, 2.5 D 4x4	with clamps;	<b>LM-10002S</b>		d1=10; d2=40; L [mm]=160
<b>TRAFIC Van (TXX)</b>				<b>03/1989 → 03/2001</b>	
Control Arm-/Trailing Arm Bush	1.4, 2.2, 2.2 4x4		<b>F8-5071</b>		d=18; L=58.5; D=36
Control Arm-/Trailing Arm Bush	2.1 D	J8S 758	<b>F8-5071</b>		d=18; L=58.5; D=36
Control Arm-/Trailing Arm Bush	2.5 D	S8U 758	<b>F8-5071</b>		d=18; L=58.5; D=36
Control Arm-/Trailing Arm Bush	2.5 D 4x4	S8U 750	<b>F8-5071</b>		d=18; L=58.5; D=36
Stabiliser Mounting	1.4, 1.7, 1.9 D, 2.0, 2.1 D, 2.2, 2.2 4x4, 2.5 D, 2.5 D 4x4		<b>F8-5096</b>		d=25.5
Engine Mounting	1.4, 1.7, 1.9 D, 2.0, 2.1 D, 2.2, 2.2 4x4, 2.5 D, 2.5 D 4x4		<b>F8-5486</b>		
Control Arm-/Trailing Arm Bush	1.4, 2.1 D, 2.2, 2.2 4x4, 2.5 D, 2.5 D 4x4		<b>F8-5805</b>		
Engine Mounting	1.9 D, 2.1 D, 2.2, 2.2 4x4		<b>F8-6839</b>		
Engine Mounting	2.5 D	09/1994 →	<b>F8-6839</b>		
Engine Mounting	1.4, 1.7, 2.0, 2.5 D		<b>F8-6866</b>		
Belt Pulley, crankshaft	2.1 D	10/1994 →; Number of Ribs: 2	<b>F8-7091</b>		Belt Pulley Ø [mm]=142; Mounting points diam.[mm]=15; W=38
Bellow, steering	1.4, 1.7, 1.9 D, 2.0, 2.1 D, 2.2, 2.2 4x4, 2.5 D, 2.5 D 4x4	with clamps;	<b>LM-10002S</b>		d1=10; d2=40; L [mm]=160
<b>TRAFIC Platform/Chassis (PXX)</b>				<b>03/1989 → 03/2001</b>	
Control Arm-/Trailing Arm Bush	2.0 [RWD]		<b>F8-5071</b>		d=18; L=58.5; D=36
Control Arm-/Trailing Arm Bush	2.5 D	S8U 720	<b>F8-5071</b>		d=18; L=58.5; D=36
Stabiliser Mounting	1.7, 2.0 [RWD], 2.1 D [RWD], 2.5 D		<b>F8-5096</b>		d=25.5
Engine Mounting	1.7, 2.0 [RWD], 2.1 D [RWD]		<b>F8-5486</b>		
Engine Mounting	2.1 D [RWD]		<b>F8-6839</b>		
Engine Mounting	1.7, 2.0 [RWD], 2.1 D [RWD]		<b>F8-6866</b>		
Belt Pulley, crankshaft	2.1 D [RWD]	10/1994 →; Number of Ribs: 2	<b>F8-7091</b>		Belt Pulley Ø [mm]=142; Mounting points diam.[mm]=15; W=38
Bellow, steering	All Models	with clamps;	<b>LM-10002S</b>		d1=10; d2=40; L [mm]=160

<b>F8-5071</b>	<b>F8-5096</b>	<b>F8-5486</b>	<b>F8-5805</b>	<b>F8-6839</b>	<b>F8-6866</b>	<b>F8-7091</b>
Ref.Nr.: 7701349064	Ref.Nr.: 7700667186	Ref.Nr.: 7700745290	Ref.Nr.: 7700730733	Ref.Nr.: 7700748646	Ref.Nr.: 7700702890	Ref.Nr.: 7700853470
<b>F8-7093S1</b>	<b>LM-10002S</b>					
Ref.Nr.: 12303AW300	Ref.Nr.: 7700706007					

Article Description



Article Nr.

Fitting Position



TRAFIC II Bus (JL)			03/2001 → 07/2003		
Alternator Freewheel Clutch	1.9 dCi, 1.9 dCi 100, 1.9 dCi 80, 2.0, 2.0 16V, 2.5 dCi 135, 2.5 DTi		F5-1025		
Alternator Freewheel Clutch	1.9 dCi, 1.9 dCi 100, 1.9 dCi 80, 2.0, 2.0 16V		F5-1036		
Alternator Freewheel Clutch	2.5 dCi 145		F5-1063		
Alternator Freewheel Clutch	2.0 dCi 115, 2.0 dCi 90		F5-1110		
Engine Mounting	2.0		F8-5486	⊕ ⊕	
Top Strut Mounting	1.9 dCi, 1.9 dCi 100, 1.9 dCi 80, 2.0, 2.0 16V, 2.0 dCi 115, 2.0 dCi 90, 2.5 dCi 135, 2.5 dCi 145, 2.5 DTi		F8-6196	⊕ ⊕ ⊕	
Top Strut Mounting	1.9 dCi, 1.9 dCi 100, 1.9 dCi 80, 2.0, 2.0 16V, 2.0 dCi 115, 2.0 dCi 90, 2.5 dCi 135, 2.5 dCi 145, 2.5 DTi		F8-6197	⊕ ⊕ ⊕	
Bellow Set, steering	1.9 dCi, 1.9 dCi 100, 1.9 dCi 80, 2.0, 2.0 16V, 2.0 dCi 115, 2.0 dCi 90, 2.5 dCi 135, 2.5 dCi 145, 2.5 DTi	with clamps	F8-6478	⊕ ⊕ ⊕	d1=13; d2=54,5; L [mm]=215
Mounting, axle beam	1.9 dCi, 1.9 dCi 100, 1.9 dCi 80, 2.0, 2.0 16V, 2.0 dCi 115, 2.5 dCi 135, 2.5 dCi 145, 2.5 DTi		F8-6661	⊕ ⊕	
Top Strut Mounting	1.9 dCi, 1.9 dCi 100, 1.9 dCi 80, 2.0, 2.0 16V, 2.0 dCi 115, 2.0 dCi 90, 2.5 dCi 135, 2.5 dCi 145, 2.5 DTi		F8-6689	⊕ ⊕ ⊕ ↑	
Engine Mounting	1.9 dCi, 1.9 dCi 100, 1.9 dCi 80, 2.0, 2.0 16V		F8-6690	⊕	
Engine Mounting	1.9 dCi, 1.9 dCi 100, 1.9 dCi 80, 2.0, 2.0 16V		F8-6691	⊕	
Engine Mounting	2.0 dCi 115	M9R 780, M9R 782, M9R 786; not for M9R630, M9R692	F8-6691	⊕	
Engine Mounting	2.0 dCi 90	not for  M9R630, M9R692	F8-6691	⊕	
Engine Mounting	1.9 dCi, 1.9 dCi 100, 1.9 dCi 80, 2.0, 2.0 16V		F8-6692	↑	
Engine Mounting	1.9 dCi, 1.9 dCi 100, 1.9 dCi 80, 2.0, 2.0 16V		F8-6693	↓	
Belt Pulley, crankshaft	2.5 dCi 135	Number of Ribs: 6	F8-7092		Belt Pulley Ø [mm]=152; Mounting points diam.[mm]=30.6; W=45.5
Anti-Friction Bearing	1.9 dCi 100, 1.9 dCi 80, 2.0, 2.0 16V, 2.0 dCi 115, 2.5 dCi 135, 2.5 dCi 145		F8-7151		H1=15; H2=12; d=16; D=52
Belt Pulley, crankshaft	2.0 dCi 115, 2.0 dCi 90	Number of Ribs: 6; Parameter: 7PK	F8-7657		
Engine Mounting	2.0 dCi 115, 2.0 dCi 90, 2.5 dCi 115, 2.5 dCi 135, 2.5 dCi 145		F8-7733	⊕	
Engine Mounting	2.0 dCi 115, 2.0 dCi 90, 2.5 dCi 115, 2.5 dCi 135, 2.5 dCi 145		F8-7736	↓	
Engine Mounting	2.0 dCi 115, 2.0 dCi 90		F8-7737	⊕ ↑	
Control Arm-/Trailing Arm Bush	1.9 dCi, 1.9 dCi 100, 1.9 dCi 80, 2.0, 2.0 16V, 2.0 dCi 90, 2.5 dCi 135, 2.5 dCi 145, 2.5 DTi		F8-7988	⊕ ⊕ ⊕	
Control Arm-/Trailing Arm Bush	2.0 dCi 115	M9R 780, M9R 782, M9R 786	F8-7988	⊕ ⊕ ⊕	

<b>F5-1025</b>	<b>F5-1036</b>	<b>F5-1063</b>	<b>F5-1110</b>	<b>F8-5486</b>	<b>F8-6196</b>	<b>F8-6197</b>
Ref.Nr.: 23151-00Q0B	Ref.Nr.: 23151-00Q0A	Ref.Nr.:	Ref.Nr.: 8200489514	Ref.Nr.: 7700745290	Ref.Nr.: 54320-00QAA	Ref.Nr.: 7701207491SK
<b>F8-6478</b>	<b>F8-6661</b>	<b>F8-6689</b>	<b>F8-6690</b>	<b>F8-6691</b>	<b>F8-6692</b>	<b>F8-6693</b>
Ref.Nr.: 48203-00QAE	Ref.Nr.: 4412907	Ref.Nr.: 8200010494	Ref.Nr.: 11323-00QAA	Ref.Nr.: 11246-00QAB	Ref.Nr.: 11356-00QAA	Ref.Nr.: 11238-00QAA
<b>F8-7092</b>	<b>F8-7151</b>	<b>F8-7657</b>	<b>F8-7733</b>	<b>F8-7736</b>	<b>F8-7737</b>	<b>F8-7988</b>
Ref.Nr.: 8200207436	Ref.Nr.: 4408056	Ref.Nr.: 1230300Q0A	Ref.Nr.: 11323-00QAB	Ref.Nr.: 4411938	Ref.Nr.: 93853920	Ref.Nr.: 8200002869

**Article Description****Article Nr.****Fitting Position**

<b>TRAFIC II Van (FL)</b>		<b>03/2001 → 07/2003</b>	
Alternator Freewheel Clutch	1.9 dCi, 1.9 dCi 100, 1.9 dCi 80, 2.0, 2.0 16V, 2.5 dCi 135, 2.5 DTi		<b>F5-1025</b>
Alternator Freewheel Clutch	1.9 dCi 100, 1.9 dCi 80, 2.0, 2.0 16V		<b>F5-1036</b>
Alternator Freewheel Clutch	2.5 dCi 145		<b>F5-1063</b>
Alternator Freewheel Clutch	2.0 dCi 115, 2.0 dCi 90		<b>F5-1110</b>
Top Strut Mounting	1.9 dCi, 1.9 dCi 100, 1.9 dCi 80, 2.0, 2.0 16V, 2.0 dCi 115, 2.0 dCi 90, 2.5 dCi 135, 2.5 dCi 145, 2.5 DTi		<b>F8-6196</b>
Top Strut Mounting	1.9 dCi, 1.9 dCi 100, 1.9 dCi 80, 2.0, 2.0 16V, 2.0 dCi 115, 2.0 dCi 90, 2.5 dCi 135, 2.5 dCi 145, 2.5 DTi		<b>F8-6197</b>
Bellow Set, steering	1.9 dCi, 1.9 dCi 100, 1.9 dCi 80, 2.0, 2.0 16V, 2.0 dCi 115, 2.0 dCi 90, 2.5 dCi 135, 2.5 dCi 145, 2.5 DTi	with clamps	<b>F8-6478</b>
Mounting, axle beam	1.9 dCi, 1.9 dCi 100, 1.9 dCi 80, 2.0, 2.0 16V, 2.0 dCi 115, 2.0 dCi 90, 2.5 dCi 135, 2.5 dCi 145, 2.5 DTi		<b>F8-6661</b>
Top Strut Mounting	1.9 dCi, 1.9 dCi 100, 1.9 dCi 80, 2.0, 2.0 16V, 2.0 dCi 115, 2.0 dCi 90, 2.5 dCi 135, 2.5 dCi 145, 2.5 DTi		<b>F8-6689</b>
Engine Mounting	1.9 dCi 100, 1.9 dCi 80, 2.0, 2.0 16V		<b>F8-6690</b>
Engine Mounting	1.9 dCi 100, 1.9 dCi 80, 2.0, 2.0 16V		<b>F8-6691</b>
Engine Mounting	2.0 dCi 115	M9R 780, M9R 782, M9R 786; not for  M9R630, M9R692	<b>F8-6691</b>
Engine Mounting	2.0 dCi 90	M9R 780; not for  M9R630, M9R692	<b>F8-6691</b>
Engine Mounting	1.9 dCi 100, 1.9 dCi 80, 2.0, 2.0 16V		<b>F8-6692</b>
Engine Mounting	1.9 dCi 100, 1.9 dCi 80, 2.0, 2.0 16V		<b>F8-6693</b>
Belt Pulley, crankshaft	2.5 dCi 135	Number of Ribs: 6	<b>F8-7092</b>
Anti-Friction Bearing	1.9 dCi 100, 1.9 dCi 80, 2.0, 2.0 16V, 2.0 dCi 115, 2.0 dCi 90, 2.5 dCi 135, 2.5 dCi 145		<b>F8-7151</b>
Belt Pulley, crankshaft	2.0 dCi 115, 2.0 dCi 90	Number of Ribs: 6; Parameter: 7PK	<b>F8-7657</b>
Engine Mounting	2.0 dCi 115, 2.0 dCi 90, 2.5 dCi 135, 2.5 dCi 145		<b>F8-7733</b>
Engine Mounting	2.0 dCi 115, 2.0 dCi 90, 2.5 dCi 135, 2.5 dCi 145		<b>F8-7736</b>
Engine Mounting	2.0 dCi 115, 2.0 dCi 90		<b>F8-7737</b>
Control Arm-/Trailing Arm Bush	1.9 dCi 80	F9Q 760, F9Q 762	<b>F8-7988</b>
Control Arm-/Trailing Arm Bush	1.9 dCi, 1.9 dCi 100, 2.0 16V, 2.5 dCi, 2.5 dCi 135, 2.5 dCi 145, 2.5 DTi		<b>F8-7988</b>
Control Arm-/Trailing Arm Bush	2.0	F4R 720	<b>F8-7988</b>

<b>F5-1025</b>	<b>F5-1036</b>	<b>F5-1063</b>	<b>F5-1110</b>	<b>F8-6196</b>	<b>F8-6197</b>	<b>F8-6478</b>
Ref.Nr.: 23151-00Q0B	Ref.Nr.: 23151-00Q0A	Ref.Nr.:	Ref.Nr.: 8200489514	Ref.Nr.: 54320-00QAA	Ref.Nr.: 7701207491SK	Ref.Nr.: 48203-00QAE
<b>F8-6661</b>	<b>F8-6689</b>	<b>F8-6690</b>	<b>F8-6691</b>	<b>F8-6692</b>	<b>F8-6693</b>	<b>F8-7092</b>
Ref.Nr.: 4412907	Ref.Nr.: 8200010494	Ref.Nr.: 11323-00QAA	Ref.Nr.: 11246-00QAB	Ref.Nr.: 11356-00QAA	Ref.Nr.: 11238-00QAA	Ref.Nr.: 8200207436
<b>F8-7151</b>	<b>F8-7657</b>	<b>F8-7733</b>	<b>F8-7736</b>	<b>F8-7737</b>	<b>F8-7988</b>	
Ref.Nr.: 4408056	Ref.Nr.: 1230300Q0A	Ref.Nr.: 11323-00QAB	Ref.Nr.: 4411938	Ref.Nr.: 93853920	Ref.Nr.: 8200002869	

Article Description			Article Nr.	Fitting Position	
---------------------	--	--	-------------	------------------	--

<b>TRAFIC II Van (FL)</b>			03/2001 → 07/2003		
Control Arm-/Trailing Arm Bush	2.0 dCi 115	M9R 780, M9R 782, M9R 786	<b>F8-7988</b>	⊕ ⊕ ⊕	
Control Arm-/Trailing Arm Bush	2.0 dCi 90	M9R 780	<b>F8-7988</b>	⊕ ⊕ ⊕	

<b>TRAFIC II Platform/Chassis (EL)</b>			03/2001 → 07/2003		
Alternator Freewheel Clutch	1.9 dCi, 1.9 dCi 100, 1.9 dCi 80, 2.0, 2.5 dCi 135		<b>F5-1025</b>		
Alternator Freewheel Clutch	1.9 dCi 100, 1.9 dCi 80, 2.0		<b>F5-1036</b>		
Alternator Freewheel Clutch	2.5 dCi, 2.5 dCi 145		<b>F5-1063</b>		
Alternator Freewheel Clutch	2.0 dCi 115, 2.0 dCi 90		<b>F5-1110</b>		
Top Strut Mounting	1.9 dCi, 1.9 dCi 100, 1.9 dCi 80, 2.0, 2.0 dCi 115, 2.0 dCi 90, 2.5 dCi 135, 2.5 dCi 145		<b>F8-6196</b>	⊕ ⊕ ⊕	
Top Strut Mounting	1.9 dCi, 1.9 dCi 100, 1.9 dCi 80, 2.0, 2.0 dCi 115, 2.0 dCi 90, 2.5 dCi, 2.5 dCi 135, 2.5 dCi 145		<b>F8-6197</b>	⊕ ⊕ ⊕	
Bellow Set, steering	1.9 dCi, 1.9 dCi 100, 1.9 dCi 80, 2.0, 2.0 dCi 115, 2.0 dCi 90, 2.5 dCi 135, 2.5 dCi 145	with clamps	<b>F8-6478</b>	⊕ ⊕ ⊕	d1=13; d2=54,5; L [mm]=215
Mounting, axle beam	1.9 dCi, 1.9 dCi 100, 1.9 dCi 80, 2.0, 2.0 dCi 115, 2.0 dCi 90, 2.5 dCi 135, 2.5 dCi 145		<b>F8-6661</b>	⊕ ⊕ ⊕	
Top Strut Mounting	1.9 dCi, 1.9 dCi 100, 1.9 dCi 80, 2.0, 2.0 dCi 115, 2.0 dCi 90, 2.5 dCi, 2.5 dCi 135, 2.5 dCi 145		<b>F8-6689</b>	⊕ ⊕ ⊕ ↑	
Engine Mounting	1.9 dCi 100, 1.9 dCi 80, 2.0		<b>F8-6690</b>	⊕	
Engine Mounting	1.9 dCi 100, 1.9 dCi 80, 2.0		<b>F8-6691</b>	⊕	
Engine Mounting	2.0 dCi 115	M9R 780, M9R 782, M9R 786; not for  M9R630, M9R692	<b>F8-6691</b>	⊕	
Engine Mounting	2.0 dCi 90	M9R 780; not for  M9R630, M9R692	<b>F8-6691</b>	⊕	
Engine Mounting	1.9 dCi 100, 1.9 dCi 80, 2.0		<b>F8-6692</b>	↑	
Engine Mounting	1.9 dCi 100, 1.9 dCi 80, 2.0		<b>F8-6693</b>	↓	
Belt Pulley, crankshaft	2.5 dCi 135	09/2002 →; Number of Ribs: 6	<b>F8-7092</b>		Belt Pulley Ø [mm]=152; Mounting points diam.[mm]=30.6; W=45.5
Anti-Friction Bearing	1.9 dCi 100, 1.9 dCi 80, 2.0, 2.0 dCi 115, 2.0 dCi 90, 2.5 dCi 135, 2.5 dCi 145		<b>F8-7151</b>		H1=15; H2=12; d=16; D=52
Belt Pulley, crankshaft	2.0 dCi 115, 2.0 dCi 90	Number of Ribs: 6; Parameter: 7PK	<b>F8-7657</b>		
Engine Mounting	2.0 dCi 115, 2.0 dCi 90, 2.5 dCi 135, 2.5 dCi 145		<b>F8-7733</b>	⊕	
Engine Mounting	2.0 dCi 115, 2.0 dCi 90, 2.5 dCi 135, 2.5 dCi 145		<b>F8-7736</b>	↓	
Engine Mounting	2.0 dCi 115, 2.0 dCi 90		<b>F8-7737</b>	⊕ ↑	
Control Arm-/Trailing Arm Bush	1.9 dCi, 1.9 dCi 100, 1.9 dCi 80, 2.0, 2.0 dCi 115, 2.0 dCi 90, 2.5 dCi, 2.5 dCi 135, 2.5 dCi 145		<b>F8-7988</b>	⊕ ⊕ ⊕	

<b>TWINGO I (C06 )</b>			03/1993 → 06/2007		
Dust Cover Kit, shock absorber	1.2, 1.2 16V		<b>AK-735256</b>	⊕ ⊕ ⊕	

<b>AK-735256</b>	<b>AK-735257</b>	<b>F5-1025</b>	<b>F5-1036</b>	<b>F5-1063</b>	<b>F5-1110</b>	<b>F8-6196</b>
Ref.Nr.: 7700821159	Ref.Nr.: 7700802667	Ref.Nr.: 23151-00Q0B	Ref.Nr.: 23151-00Q0A	Ref.Nr.:	Ref.Nr.: 8200489514	Ref.Nr.: 54320-00QAA
<b>F8-6197</b>	<b>F8-6478</b>	<b>F8-6661</b>	<b>F8-6689</b>	<b>F8-6690</b>	<b>F8-6691</b>	<b>F8-6692</b>
Ref.Nr.: 7701207491SK	Ref.Nr.: 48203-00QAE	Ref.Nr.: 4412907	Ref.Nr.: 8200010494	Ref.Nr.: 11323-00QAA	Ref.Nr.: 11246-00QAB	Ref.Nr.: 11356-00QAA
<b>F8-6693</b>	<b>F8-7092</b>	<b>F8-7151</b>	<b>F8-7657</b>	<b>F8-7733</b>	<b>F8-7736</b>	<b>F8-7737</b>
Ref.Nr.: 11238-00QAA	Ref.Nr.: 8200207436	Ref.Nr.: 4408056	Ref.Nr.: 1230300Q0A	Ref.Nr.: 11323-00QAB	Ref.Nr.: 4411938	Ref.Nr.: 93853920

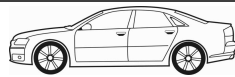
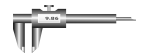
**Article Description****Article Nr.****Fitting Position**

<b>TWINGO I (C06_)</b>			<b>03/1993 → 06/2007</b>		
Dust Cover Kit, shock absorber	1.2, 1.2 16V		<b>AK-735257</b>		
Anti-Friction Bearing	1.2, 1.2 16V		<b>F8-3032</b>		H=9; d1=16; d2=27; D=56
Top Strut Mounting	1.2, 1.2 16V		<b>F8-5389</b>		
Spring Cap	1.2	D7F 702	<b>F8-5488</b>		
Spring Cap	1.2, 1.2 16V		<b>F8-5488</b>		
Spring Cap	1.2 16V	D4F704	<b>F8-5488</b>		
Rubber Buffer, suspension	1.2, 1.2 16V		<b>F8-5800</b>		
Top Strut Mounting	1.2, 1.2 16V		<b>F8-5801</b>		
Mounting, axle beam	1.2, 1.2 16V		<b>F8-5810</b>		H=70; d=10; D=40
Rubber Buffer, suspension	1.2, 1.2 16V		<b>F8-5862</b>		
Repair Kit, suspension strut	1.2	with mounting parts	<b>F8-6376</b>		
Repair Kit, suspension strut	1.2	with mounting parts; Type: C066, C068, C06G, C06M	<b>F8-6376</b>		
Repair Kit, suspension strut	1.2 16V	with mounting parts; Type: C060, C061, C062, C06C, C06D, C06K, C06N, C06R, C06W	<b>F8-6376</b>		
Engine Mounting	1.2, 1.2 16V		<b>F8-6861</b>		
Engine Mounting	1.2		<b>F8-6874</b>		
Engine Mounting	1.2	Type: C066	<b>F8-6874</b>		
Engine Mounting	1.2		<b>F8-6877</b>		
Bearing, drive shaft	1.2		<b>F8-7173</b>		d=25.8
Spring Cap	1.2, 1.2 16V		<b>F8-7341</b>		
Control Arm-/Trailing Arm Bush	1.2, 1.2 16V		<b>G9-603</b>		H1=34; H2=46; d=12; D=36
Control Arm-/Trailing Arm Bush	1.2, 1.2 16V		<b>G9-604</b>		H=46; d=12; D1=38; D2=49
Bellow, steering	1.2, 1.2 16V	with clamps;	<b>LM-10001S</b>		d1=10; d2=30; L [mm]=158
Bellow, steering	1.2, 1.2 16V	with clamps;	<b>LM-10042S</b>		d1=10; d2=27.5; L [mm]=155
Bellow Set, drive shaft	1.2		<b>M-870870</b>		
Bellow Set, drive shaft	1.2		<b>MK-870870</b>		
<b>TWINGO I Van (S06_)</b>			<b>03/1993 → 05/1996</b>		
Anti-Friction Bearing	All Models		<b>F8-3032</b>		H=9; d1=16; d2=27; D=56
Top Strut Mounting	All Models		<b>F8-5389</b>		
Spring Cap	All Models		<b>F8-5488</b>		
Rubber Buffer, suspension	All Models		<b>F8-5800</b>		
Top Strut Mounting	All Models		<b>F8-5801</b>		
Rubber Buffer, suspension	All Models		<b>F8-5862</b>		

<b>AK-735257</b>	<b>F8-3032</b>	<b>F8-5389</b>	<b>F8-5488</b>	<b>F8-5800</b>	<b>F8-5801</b>	<b>F8-5810</b>
Ref.Nr.: 7700802667	Ref.Nr.: 8200651172	Ref.Nr.: 7700827435	Ref.Nr.: 7700828866	Ref.Nr.: 7700821159	Ref.Nr.: 7700840056	Ref.Nr.: 7700821167
<b>F8-5862</b>	<b>F8-6376</b>	<b>F8-6861</b>	<b>F8-6874</b>	<b>F8-6877</b>	<b>F8-7173</b>	<b>F8-7341</b>
Ref.Nr.: 7700819237	Ref.Nr.: 7700820501	Ref.Nr.: 7700821670	Ref.Nr.: 7700411949	Ref.Nr.: 7700412094	Ref.Nr.: 7664079	Ref.Nr.: 7700819502
<b>G9-603</b>	<b>G9-604</b>	<b>LM-10001S</b>	<b>LM-10042S</b>	<b>M-870870</b>	<b>MK-870870</b>	
Ref.Nr.: 7700819929	Ref.Nr.: 7700819928	Ref.Nr.: 7700678649	Ref.Nr.: 7701469497	Ref.Nr.: 7701450617	Ref.Nr.: 7701450617	

Article Description



Article Nr.

Fitting Position



<b>TWINGO I Van (S06_)</b>			<b>03/1993 → 05/1996</b>		
Repair Kit, suspension strut	1.2	☉, with mounting parts	<b>F8-6376</b>		
Repair Kit, suspension strut	1.2	☉, with mounting parts; Type: S066, S068	<b>F8-6376</b>		
Engine Mounting	1.2		<b>F8-6861</b>		
Engine Mounting	1.2		<b>F8-6877</b>		
Control Arm-/Trailing Arm Bush	All Models		<b>G9-603</b>		H1=34; H2=46; d=12; D=36
Control Arm-/Trailing Arm Bush	All Models		<b>G9-604</b>		H=46; d=12; D1=38; D2=49
Bellow, steering	All Models	with clamps; ☉	<b>LM-10001S</b>		d1=10; d2=30; L [mm]=158
Bellow, steering	All Models	with clamps; ☉	<b>LM-10042S</b>		d1=10; d2=27.5; L [mm]=155
Bellow Set, drive shaft	All Models		<b>M-870870</b>		
<b>TWINGO II (CNO_)</b>			<b>03/2007 →</b>		
Alternator Freewheel Clutch	1.5 dCi		<b>F5-1061</b>		
Alternator Freewheel Clutch	1.5 dCi 90	K9K 830	<b>F5-1061</b>		
Alternator Freewheel Clutch	1.5 dCi		<b>F5-1083</b>		
Alternator Freewheel Clutch	1.5 dCi , 1.5 dCi 75, 1.5 dCi 90		<b>F5-1122</b>		
Anti-Friction Bearing	1.2 , 1.2 16V , 1.2 TCe 100 , 1.2 Turbo , 1.5 dCi , 1.5 dCi 75, 1.6 RS		<b>F8-3032</b>		H=9; d1=16; d2=27; D=56
Top Strut Mounting	All Models		<b>F8-5496</b>		
Belt Pulley, crankshaft	1.5 dCi		<b>F8-5657</b>		
Mounting, axle beam	1.2 , 1.2 16V , 1.2 Turbo , 1.5 dCi	01/2008 →	<b>F8-6174</b>		H1=72; H2=50.5; d=10; D=45.5
Mounting, axle beam	1.6 RS		<b>F8-6174</b>		H1=72; H2=50.5; d=10; D=45.5
Top Strut Mounting	1.2 , 1.2 16V , 1.2 TCe 100 , 1.2 Turbo , 1.5 dCi , 1.5 dCi 75, 1.6 RS		<b>F8-6329</b>		
Engine Mounting	1.2 , 1.2 16V , 1.2 TCe 100 , 1.2 Turbo , 1.5 dCi , 1.5 dCi 75, 1.5 dCi 90, 1.6 RS		<b>F8-8151</b>		
<b>VEL SATIS (BJ0_)</b>			<b>06/2002 →</b>		
Dust Cover Kit, shock absorber	2.0 16 V Turbo, 2.0 16V Turbo , 2.0 dCi , 2.0 Turbo, 2.2 dCi , 3.0 dCi , 3.5 , 3.5 V6		<b>AK-735062</b>		
Alternator Freewheel Clutch	3.0 dCi		<b>F5-1096</b>		
Alternator Freewheel Clutch	2.0 dCi		<b>F5-1110</b>		
Engine Mounting	2.2 dCi , 3.0 dCi , 3.5 V6		<b>F8-6667</b>		
Engine Mounting	2.0 16 V Turbo, 2.0 16V Turbo , 2.0 Turbo		<b>F8-6668</b>		
Engine Mounting	2.0 16 V Turbo, 2.0 16V Turbo , 2.0 dCi , 2.2 dCi , 3.0 dCi , 3.5 V6		<b>F8-6671</b>		
Engine Mounting	2.0 16 V Turbo, 2.0 16V Turbo , 2.0 dCi , 2.2 dCi , 3.0 dCi , 3.5 V6		<b>F8-6672</b>		

<b>AK-735062</b>	<b>F5-1061</b>	<b>F5-1083</b>	<b>F5-1096</b>	<b>F5-1110</b>	<b>F5-1122</b>	<b>F8-3032</b>
Ref.Nr.: 8200180137	Ref.Nr.: 7700110616	Ref.Nr.:	Ref.Nr.: 7701066401	Ref.Nr.: 8200489514	Ref.Nr.:	Ref.Nr.: 8200651172
<b>F8-5496</b>	<b>F8-5657</b>	<b>F8-6174</b>	<b>F8-6329</b>	<b>F8-6376</b>	<b>F8-6667</b>	<b>F8-6668</b>
Ref.Nr.: 7700829529	Ref.Nr.: 8200185800	Ref.Nr.: 7700429441	Ref.Nr.: 7700829529	Ref.Nr.: 7700820501	Ref.Nr.: 8200250743	Ref.Nr.: 8200181589
<b>F8-6671</b>	<b>F8-6672</b>	<b>F8-6861</b>	<b>F8-6877</b>	<b>F8-7092</b>	<b>F8-8151</b>	<b>G9-603</b>
Ref.Nr.: 8200000514	Ref.Nr.: 8200000515	Ref.Nr.: 7700821670	Ref.Nr.: 7700412094	Ref.Nr.: 8200207436	Ref.Nr.: 8200151995	Ref.Nr.: 7700819929

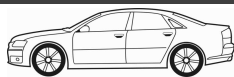
**Article Description****Article Nr.****Fitting Position**

<b>VEL SATIS (BJ0_)</b>				<b>06/2002 →</b>	
Belt Pulley, crankshaft	2.2 dCi	03/2005 →; Number of Ribs: 6	<b>F8-7092</b>		Belt Pulley Ø [mm]=152; Mounting points diam.[mm]=30.6; W=45.5
Belt Pulley, crankshaft	2.2 dCi	Number of Ribs: 6	<b>F8-7092</b>		Belt Pulley Ø [mm]=152; Mounting points diam.[mm]=30.6; W=45.5
Supporting Ring, suspension strut bearing	2.0 16V Turbo, 2.0 16V Turbo, 2.0 dCi, 2.0 Turbo, 2.2 dCi, 3.0 dCi, 3.5, 3.5 V6		<b>F8-7469</b>		
Anti-Friction Bearing	2.0 16V Turbo, 2.0 16V Turbo, 2.0 dCi, 2.0 Turbo, 2.2 dCi, 3.0 dCi, 3.5, 3.5 V6		<b>F8-7633</b>		
Control Arm-/Trailing Arm Bush	All Models		<b>F8-7990</b>		
<b>WIND (E4M_)</b>				<b>07/2010 →</b>	
Engine Mounting	1.2, 1.6		<b>F8-8151</b>		
<b>LOGAN EXPRESS</b>				<b>04/2007 →</b>	
Alternator Freewheel Clutch	1.5 dCi		<b>F5-1061</b>		
Anti-Friction Bearing	All Models		<b>F8-3032</b>		H=9; d1=16; d2=27; D=56
Top Strut Mounting	All Models		<b>F8-6596</b>		
Engine Mounting	1.6		<b>F8-6711</b>		
Rubber Buffer, suspension	All Models		<b>F8-7900</b>		
Control Arm-/Trailing Arm Bush	All Models		<b>F8-7977</b>		
<b>LOGAN II</b>				<b>11/2013 →</b>	
Rubber Buffer, suspension	1.2		<b>F8-7900</b>		
<b>MEGANE [USA]</b>				<b>01/2004 → 12/2009</b>	
Engine Mounting	All Models		<b>F8-8162</b>		

<b>F5-1061</b>	<b>F8-3032</b>	<b>F8-6596</b>	<b>F8-6711</b>	<b>F8-7092</b>	<b>F8-7469</b>	<b>F8-7633</b>
Ref.Nr.: 7700110616	Ref.Nr.: 8200651172	Ref.Nr.: 6001547499	Ref.Nr.: 112107695R	Ref.Nr.: 8200207436	Ref.Nr.: 7700424482	Ref.Nr.: 7700424481
<b>F8-7900</b>	<b>F8-7977</b>	<b>F8-7990</b>	<b>F8-8151</b>	<b>F8-8162</b>		
Ref.Nr.: 6001548402	Ref.Nr.: 6040002245	Ref.Nr.: 8200002868	Ref.Nr.: 8200151995	Ref.Nr.: 8200042454		

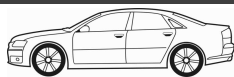
**Article Description**

**Article Nr.**
**Fitting Position**

<b>25 (RF)</b>		<b>10/1999 → 05/2005</b>	
Dust Cover Kit, shock absorber	1.1 16V, 1.4 16V, 1.6 16V, 1.8 16V, 2.0 iDT	<b>AK-735397</b>	
Dust Cover Kit, shock absorber	1.1 16V, 1.4 16V, 1.6 16V, 1.8 16V, 2.0 iDT	<b>AK-735398</b>	
Control Arm-/Trailing Arm Bush	1.1 16V, 1.4 16V, 1.6 16V, 1.8 16V, 2.0 iDT	<b>F8-5123</b>	 H1=50; H2=30; d=10; D=32
Control Arm-/Trailing Arm Bush	1.4 16V, 1.6 16V, 1.8 16V, 2.0 iDT	<b>F8-5988</b>	 D=80
<b>45 (RT)</b>		<b>02/2000 → 05/2005</b>	
Dust Cover Kit, shock absorber	1.4, 1.6, 1.8, 2.0 iDT, 2.0 V6	<b>AK-735399</b>	
Dust Cover Kit, shock absorber	1.4, 1.6, 1.8, 2.0 iDT, 2.0 V6	<b>AK-735400</b>	
Control Arm-/Trailing Arm Bush	1.4, 1.6, 1.8, 2.0 iDT, 2.0 V6	<b>F8-5988</b>	 D=80
<b>45 Saloon (RT)</b>		<b>02/2000 → 05/2005</b>	
Dust Cover Kit, shock absorber	1.4, 1.6, 1.8, 2.0 iDT, 2.0 V6	<b>AK-735399</b>	
Dust Cover Kit, shock absorber	1.4, 1.6, 1.8, 2.0 iDT, 2.0 V6	<b>AK-735400</b>	
Control Arm-/Trailing Arm Bush	1.4, 1.6, 1.8, 2.0 iDT, 2.0 V6	<b>F8-5988</b>	 D=80
<b>75 (RJ)</b>		<b>02/1999 → 05/2005</b>	
Dust Cover Kit, shock absorber	1.8, 1.8 Turbo, 2.0 CDT, 2.0 CDTi, 2.0 V6, 2.5 V6	<b>AK-735122</b>	
Dust Cover Kit, shock absorber	1.8, 1.8 Turbo, 2.0 CDT, 2.0 CDTi, 2.0 V6, 2.5 V6	<b>AK-735403</b>	
Control Arm-/Trailing Arm Bush	1.8, 1.8 Turbo, 2.0 CDT, 2.0 CDTi, 2.0 V6, 2.5 V6	<b>F8-8003</b>	
Control Arm-/Trailing Arm Bush	1.8, 1.8 Turbo, 2.0 CDT, 2.0 CDTi, 2.0 V6, 2.5 V6	<b>F8-8004</b>	
Control Arm-/Trailing Arm Bush	1.8, 1.8 Turbo, 2.0 CDT, 2.0 CDTi, 2.0 V6, 2.5 V6	<b>F8-8036</b>	 d=25; D=77
Control Arm-/Trailing Arm Bush	1.8, 1.8 Turbo, 2.0 CDT, 2.0 CDTi, 2.0 V6, 2.5 V6	<b>F8-8037</b>	 d=25; D=77
<b>75 Tourer (RJ)</b>		<b>08/2001 → 05/2005</b>	
Dust Cover Kit, shock absorber	1.8, 1.8 Turbo, 2.0 CDT, 2.0 CDTi, 2.0 V6, 2.5 V6	<b>AK-735122</b>	
Dust Cover Kit, shock absorber	1.8, 1.8 Turbo, 2.0 CDT, 2.0 CDTi, 2.0 V6, 2.5 V6	<b>AK-735403</b>	
Control Arm-/Trailing Arm Bush	1.8, 1.8 Turbo, 2.0 CDT, 2.0 CDTi, 2.0 V6, 2.5 V6	<b>F8-8003</b>	
Control Arm-/Trailing Arm Bush	1.8, 1.8 Turbo, 2.0 CDT, 2.0 CDTi, 2.0 V6, 2.5 V6	<b>F8-8004</b>	
Control Arm-/Trailing Arm Bush	1.8, 1.8 Turbo, 2.0 CDT, 2.0 CDTi, 2.0 V6, 2.5 V6	<b>F8-8036</b>	 d=25; D=77
Control Arm-/Trailing Arm Bush	1.8, 1.8 Turbo, 2.0 CDT, 2.0 CDTi, 2.0 V6, 2.5 V6	<b>F8-8037</b>	 d=25; D=77

<b>AK-735122</b>	<b>AK-735397</b>	<b>AK-735398</b>	<b>AK-735399</b>	<b>AK-735400</b>	<b>AK-735403</b>	<b>F8-5123</b>
Ref.Nr.: <b></b>	Ref.Nr.: <b>EAP7162</b>	Ref.Nr.: <b>RNE100060</b>	Ref.Nr.: <b>RNE100090</b>	Ref.Nr.: <b>RPC100020</b>	Ref.Nr.: <b>RNH100130</b>	Ref.Nr.: <b>51393-SK3-000</b>
<b>F8-5988</b>	<b>F8-8003</b>	<b>F8-8004</b>	<b>F8-8036</b>	<b>F8-8037</b>		
Ref.Nr.: <b>RGX100980</b>	Ref.Nr.: <b>RBX101761</b>	Ref.Nr.: <b>RBX101771</b>	Ref.Nr.: <b>RBX101770</b>	Ref.Nr.: <b>RBX101760</b>		

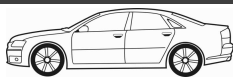

**Article Description****Article Nr.****Fitting Position**

<b>200 Coupe (XW)</b>				<b>10/1992 → 06/1999</b>	
Control Arm-/Trailing Arm Bush	216, 220 GSi, 220 Turbo		<b>F8-5123</b>		H1=50; H2=30; d=10; D=32
Control Arm-/Trailing Arm Bush	216, 220 GSi, 220 Turbo		<b>F8-5988</b>		D=80
<b>200 Hatchback (XW)</b>				<b>10/1989 → 10/1995</b>	
Control Arm-/Trailing Arm Bush	214 Si/Gsi, 216 GSi, 218 TD, 220 GTi	10/1992 →	<b>F8-5123</b>		H1=50; H2=30; d=10; D=32
Control Arm-/Trailing Arm Bush	214, 214 GSi/Si, 216 GSi, 216 GTi, 218 D, 220 GTi, 220 Turbo		<b>F8-5123</b>		H1=50; H2=30; d=10; D=32
Control Arm-/Trailing Arm Bush	All Models		<b>F8-5988</b>		D=80
<b>200 (XH)</b>				<b>03/1985 → 09/1989</b>	
Dust Cover Kit, shock absorber	All Models	Universal	<b>AK-735156</b>		
Control Arm-/Trailing Arm Bush	All Models		<b>F8-5988</b>		D=80
<b>200 (RF)</b>				<b>11/1995 → 03/2000</b>	
Dust Cover Kit, shock absorber	211, 214 i, 214 Si, 216 Si, 218 K Vi, 220 D/SD, 220 SDi		<b>AK-735397</b>		
Dust Cover Kit, shock absorber	211, 214 i, 214 Si, 216 Si, 218 K Vi, 220 D/SD, 220 SDi		<b>AK-735398</b>		
Control Arm-/Trailing Arm Bush	211, 214 i, 214 Si, 216 Si, 218 K Vi, 220 D/SD, 220 SDi		<b>F8-5123</b>		H1=50; H2=30; d=10; D=32
Control Arm-/Trailing Arm Bush	214 i, 216 Si, 218 K Vi, 220 D/SD, 220 SDi		<b>F8-5988</b>		D=80
<b>400 (RT)</b>				<b>05/1995 → 03/2000</b>	
Dust Cover Kit, shock absorber	414 Si, 416 Si, 420 D, 420 Di, 420 Si Lux		<b>AK-735399</b>		
Dust Cover Kit, shock absorber	414 Si, 416 Si, 420 D, 420 Di, 420 Si Lux		<b>AK-735400</b>		
Control Arm-/Trailing Arm Bush	414 Si, 416 Si, 420 D, 420 Di, 420 Si Lux		<b>F8-5123</b>		H1=50; H2=30; d=10; D=32
Control Arm-/Trailing Arm Bush	414 Si, 416 Si, 420 D, 420 Di, 420 Si Lux		<b>F8-5988</b>		D=80
<b>400 Hatchback (RT)</b>				<b>05/1995 → 03/2000</b>	
Dust Cover Kit, shock absorber	414 Si, 416 Si, 420 D, 420 Di, 420 Si Lux		<b>AK-735399</b>		
Dust Cover Kit, shock absorber	414 Si, 416 Si, 420 D, 420 Di, 420 Si Lux		<b>AK-735400</b>		
Control Arm-/Trailing Arm Bush	414 Si, 416 Si, 420 D, 420 Di, 420 Si Lux		<b>F8-5123</b>		H1=50; H2=30; d=10; D=32
Control Arm-/Trailing Arm Bush	416 Si		<b>F8-5123</b>		H1=50; H2=30; d=10; D=32
Control Arm-/Trailing Arm Bush	414 Si, 416 Si, 420 D, 420 Di, 420 Si Lux		<b>F8-5988</b>		D=80



Article Description			Article Nr.	Fitting Position	
<b>400 (XW)</b> <span style="float: right;"><b>04/1990 → 04/1995</b></span>					
Control Arm-/Trailing Arm Bush	414 GSI/SI, 414 GSI/SI CAT, 416 GSI, 416 GTI, 420 GTI/GSI/Vitesse		<b>F8-5123</b>		H1=50; H2=30; d=10; D=32
Control Arm-/Trailing Arm Bush	414, 416 GSI/GSE, 416 GTI/GTE, 418 D, 418 TD, 420 GSI/SLI/GTI/Vite, 420 Turbo		<b>F8-5123</b>		H1=50; H2=30; d=10; D=32
Control Arm-/Trailing Arm Bush	414, 414 GSI/SI, 414 GSI/SI CAT, 416 GSI, 416 GSI/GSE, 416 GTI, 416 GTI/GTE, 418 D, 418 TD, 420 GSI/SLI/GTI/Vite, 420 GTI/GSI/Vitesse, 420 Turbo		<b>F8-5988</b>		D=80
<b>400 Tourer (XW)</b> <span style="float: right;"><b>09/1993 → 11/1998</b></span>					
Control Arm-/Trailing Arm Bush	All Models		<b>F8-5123</b>		H1=50; H2=30; d=10; D=32
Control Arm-/Trailing Arm Bush	All Models		<b>F8-5988</b>		D=80
<b>600 (RH)</b> <span style="float: right;"><b>08/1993 → 02/1999</b></span>					
Dust Cover Kit, shock absorber	All Models		<b>AK-735401</b>		
Dust Cover Kit, shock absorber	All Models		<b>AK-735402</b>		
<b>CABRIOLET (XW)</b> <span style="float: right;"><b>01/1992 → 11/1999</b></span>					
Control Arm-/Trailing Arm Bush	216 1.6i		<b>F8-5988</b>		D=80
<b>COUPE</b> <span style="float: right;"><b>03/1996 → 11/1999</b></span>					
Control Arm-/Trailing Arm Bush	1.8 16 V		<b>F8-5988</b>		D=80
<b>MINI</b> <span style="float: right;"><b>01/1991 → 11/2000</b></span>					
Bellow, steering	1000, 1300	with clamps	<b>LM-10035S</b>		d1=10; d2=44; L [mm]=120
<b>MONTEGO</b> <span style="float: right;"><b>10/1988 → 10/1995</b></span>					
Dust Cover Kit, shock absorber	2.0 D Turbo, 2.0 GTi, 2.0 i CAT		<b>AK-735013</b>		
<b>MONTEGO Estate (XE)</b> <span style="float: right;"><b>10/1984 → 12/1993</b></span>					
Dust Cover Kit, shock absorber	1.3, 2.0 GTi, 2.0 GTi/LXI, 2.0 Turbo-D		<b>AK-735013</b>		

<b>AK-735013</b>	<b>AK-735401</b>	<b>AK-735402</b>	<b>F8-5123</b>	<b>F8-5988</b>	<b>LM-10035S</b>
Ref.Nr.:	Ref.Nr.: RNE100040	Ref.Nr.: RPY100010	Ref.Nr.: 51393-SK3-000	Ref.Nr.: RGX100980	Ref.Nr.: GSV1153

**Article Description****Article Nr.****Fitting Position**

<b>900 Mk II</b>			<b>07/1993 → 02/1998</b>	
Dust Cover Kit, shock absorber	All Models		<b>AK-735074</b>	
Mounting, stabilizer coupling rod	2.0 -16 Turbo, 2.0 i, 2.3 -16, 2.5 -24 V6		<b>F8-5333</b>	d=8.5; D=30
Anti-Friction Bearing	All Models		<b>F8-6267</b>	H=12; W=91
Control Arm-/Trailing Arm Bush	All Models	ch.S2012272, S7014773→	<b>F8-6547</b>	
Sleeve, control arm mounting	All Models		<b>F8-6656</b>	
Engine Mounting	2.0 -16 Turbo, 2.0 i, 2.3 -16, 2.5 -24 V6	01/1996 →;	<b>F8-6823</b>	
Engine Mounting	2.0 -16 Turbo, 2.3 -16, 2.5 -24 V6	01/1994 →	<b>F8-6823</b>	
Top Strut Mounting	2.0 -16 Turbo, 2.0 i, 2.3 -16, 2.5 -24 V6		<b>F8-7147</b>	
<b>900 Mk II Convertible</b>			<b>12/1993 → 02/1998</b>	
Dust Cover Kit, shock absorber	All Models		<b>AK-735074</b>	
Mounting, stabilizer coupling rod	All Models		<b>F8-5333</b>	d=8.5; D=30
Anti-Friction Bearing	2.0 -16 Turbo, 2.0 i, 2.5 -24 V6		<b>F8-6267</b>	H=12; W=91
Control Arm-/Trailing Arm Bush	All Models	ch.S2012272, S7014773→	<b>F8-6547</b>	
Sleeve, control arm mounting	All Models		<b>F8-6656</b>	
Engine Mounting	2.0 -16 Turbo, 2.0 i, 2.3 -16, 2.5 -24 V6	01/1996 →;	<b>F8-6823</b>	
Engine Mounting	2.0 -16 Turbo, 2.3 -16, 2.5 -24 V6	01/1994 →	<b>F8-6823</b>	
Top Strut Mounting	All Models		<b>F8-7147</b>	
<b>900 Mk II Coupe</b>			<b>12/1993 → 02/1998</b>	
Dust Cover Kit, shock absorber	All Models		<b>AK-735074</b>	
Mounting, stabilizer coupling rod	All Models		<b>F8-5333</b>	d=8.5; D=30
Anti-Friction Bearing	All Models		<b>F8-6267</b>	H=12; W=91
Control Arm-/Trailing Arm Bush	All Models	ch.S2012272, S7014773→	<b>F8-6547</b>	
Sleeve, control arm mounting	All Models		<b>F8-6656</b>	
Engine Mounting	2.0 -16 Turbo, 2.0 i, 2.3 -16, 2.5 -24 V6	01/1996 →;	<b>F8-6823</b>	
Engine Mounting	2.0 -16 Turbo, 2.3 -16, 2.5 -24 V6	01/1994 →	<b>F8-6823</b>	
Top Strut Mounting	All Models		<b>F8-7147</b>	
<b>9000</b>			<b>04/1985 → 12/1998</b>	
Dust Cover Kit, shock absorber	2.0 -16 CD, 2.0 -16 Turbo CD, 2.3 -16 CDE, 2.3 -16 CDE Eco-Power, 3.0 -24 V6 CD/CDE		<b>AK-735075</b>	
Stabiliser Mounting	2.0 -16 CD, 2.0 -16 Turbo CD, 2.3 -16 CD Turbo		<b>F8-5226</b>	H=21.5; d=10; D=25
Engine Mounting	2.0 -16, 2.0 -16 Turbo CD		<b>F8-7886</b>	



**Article Description**

**Article Nr.**
**Fitting Position**

<b>9000</b>		<b>04/1985 → 12/1998</b>	
Control Arm-/Trailing Arm Bush	2.0 -16, 2.0 -16 CD, 2.0 -16 Turbo, 2.0 -16 Turbo CD, 2.3 -16 CD, 2.3 -16 CD Turbo, 2.3 -16 CDE, 2.3 -16 CDE Eco-Power, 2.3 -16 Turbo, 3.0 -24 V6 CD/CDE	<b>G9-641</b>	⊕ ⊕ H=48; d=19; L=160; D=65
Control Arm-/Trailing Arm Bush	2.0 -16, 2.0 -16 CD, 2.0 -16 Turbo, 2.0 -16 Turbo CD, 2.3 -16 CD, 2.3 -16 CD Turbo, 2.3 -16 CDE, 2.3 -16 CDE Eco-Power, 2.3 -16 Turbo, 3.0 -24 V6 CD/CDE	<b>G9-643</b>	⊕ ⊕ H=54; D=35; T [mm]=105
<b>9000 Hatchback</b>		<b>09/1984 → 12/1998</b>	
Stabiliser Mounting	2.0 -16 CS, 2.0 -16 ND Turbo, 2.0 -16 Turbo, 2.0 -16 Turbo CS, 2.3 -16 Aero CS, 2.3 -16 CS, 2.3 -16 CSE, 2.3 -16 CSE Eco Power, 2.3 -16 Turbo, 2.3 -16 Turbo CSE, 3.0 -24 V6 CS/CSE	<b>F8-5226</b>	⊕ ⊕ H=21.5; d=10; D=25
Engine Mounting	2.0 -16 CS, 2.0 -16 Turbo, 2.3 -16 CS	<b>F8-7885</b>	⊕ ⊕
Engine Mounting	2.0 -16 CS, 2.0 -16 Turbo, 2.0 -16 Turbo CS, 2.3 -16 CSE, 2.3 -16 Turbo CSE	<b>F8-7886</b>	⊕ ⊕
Control Arm-/Trailing Arm Bush	2.0 -16, 2.0 -16 CS, 2.0 -16 ND Turbo, 2.0 -16 Turbo, 2.0 -16 Turbo CS, 2.3 -16 Aero CS, 2.3 -16 CS, 2.3 -16 CSE, 2.3 -16 CSE Eco Power, 2.3 -16 Turbo, 2.3 -16 Turbo CSE, 3.0 -24 V6 CS/CSE	<b>G9-641</b>	⊕ ⊕ H=48; d=19; L=160; D=65
Control Arm-/Trailing Arm Bush	2.0 -16, 2.0 -16 CS, 2.0 -16 ND Turbo, 2.0 -16 Turbo, 2.0 -16 Turbo CS, 2.3 -16 Aero CS, 2.3 -16 CS, 2.3 -16 CSE, 2.3 -16 CSE Eco Power, 2.3 -16 Turbo, 2.3 -16 Turbo CSE, 3.0 -24 V6 CS/CSE	<b>G9-643</b>	⊕ ⊕ H=54; D=35; T [mm]=105
<b>9-3 (YS3D)</b>		<b>02/1998 → 09/2002</b>	
Dust Cover Kit, shock absorber	2.0 i, 2.0 SE Turbo, 2.0 Turbo, 2.2 TiD, 2.3 i, 2.3 Turbo	<b>AK-735071</b>	
Mounting, stabilizer coupling rod	2.0 i, 2.0 SE Turbo, 2.0 Turbo, 2.2 TiD, 2.3 i, 2.3 Turbo	<b>F8-5333</b>	d=8.5; D=30
Belt Pulley, crankshaft	2.2 TiD	<b>F8-5639</b>	
Anti-Friction Bearing	All Models	<b>F8-6267</b>	H=12; W=91
Top Strut Mounting	All Models	<b>F8-6327</b>	⊕ ⊕
Control Arm-/Trailing Arm Bush	All Models	<b>F8-6547</b>	
Sleeve, control arm mounting	All Models	<b>F8-6656</b>	⊕ ⊕
Engine Mounting	2.0 SE Turbo, 2.0 Turbo	<b>F8-6823</b>	
Engine Mounting	2.3 Turbo	<b>F8-6823</b>	ch.X7051398→
Engine Mounting	2.0 i, 2.0 Turbo, 2.3 i	<b>F8-6824</b>	
Mounting, automatic transmission	2.0 i, 2.0 Turbo, 2.3 i	<b>F8-7026</b>	⊕
Mounting, automatic transmission	2.0 Turbo	<b>F8-7026</b>	⊕
<b>9-3 (YS3F)</b>			<b>09/2002 →</b>
Dust Cover Kit, shock absorber	1.8t, 1.8 i, 1.9 TiD, 2.0 t, 2.2 TiD, 2.8 Turbo V6	<b>AK-735262</b>	⊕ ⊕

<b>AK-735071</b>	<b>AK-735262</b>	<b>F5-1079</b>	<b>F8-5226</b>	<b>F8-5333</b>	<b>F8-5639</b>	<b>F8-6267</b>
Ref.Nr.:	Ref.Nr.: 12786062	Ref.Nr.: 1204376	Ref.Nr.: 8953986	Ref.Nr.: 2875013	Ref.Nr.: 0614411	Ref.Nr.: 1273747
<b>F8-6327</b>	<b>F8-6547</b>	<b>F8-6656</b>	<b>F8-6823</b>	<b>F8-6824</b>	<b>F8-7026</b>	<b>F8-7885</b>
Ref.Nr.: 5060892	Ref.Nr.: 4545711	Ref.Nr.: 4246062	Ref.Nr.: 4283891	Ref.Nr.: 4623153	Ref.Nr.: 4623146	Ref.Nr.: 7551104
<b>F8-7886</b>	<b>G9-641</b>	<b>G9-643</b>				
Ref.Nr.: 8786006	Ref.Nr.: 8965252	Ref.Nr.: 8661476				

**Article Description****Article Nr.****Fitting Position**

<b>9-3 (YS3F)</b>		<b>09/2002 →</b>	
Alternator Freewheel Clutch	1,8t, 1,8t BioPower, 2,0 t, 2,0 t Bio Power, 2,0 t BioPower, 2,0 t BioPower XWD, 2,0 t XWD, 2,0 Turbo Performance, 2,0 Turbo XWD	<b>F5-1079</b>	
Alternator Freewheel Clutch	1.9 TiD, 1.9 TTiD	<b>F5-1102</b>	
Control Arm-/Trailing Arm Bush	1,8t, 2,0 t, 2,2 TiD	<b>F8-4090</b>	H1=50; H2=59; d=12; D1=36; D2=43
Belt Pulley, crankshaft	2,2 TiD	<b>F8-5639</b>	
Control Arm-/Trailing Arm Bush	1,8t, 1,8 i, 1,9 TiD, 1,9 TTiD, 2,0 t, 2,0 t BioPower, 2,2 TiD, 2,8 Turbo V6, 2,8 Turbo V6 XWD	<b>F8-6447</b>	
Anti-Friction Bearing	1,8t, 1,8 i, 1,9 TiD, 2,0 t, 2,0 t BioPower, 2,2 TiD, 2,8 Turbo V6	<b>F8-7172</b>	
Top Strut Mounting	1,8t, 1,8 i, 1,9 TiD, 2,0 t, 2,2 TiD, 2,8 Turbo V6	<b>F8-7329</b>	
Top Strut Mounting	1,8t, 1,8 i, 1,9 TiD, 2,0 t, 2,2 TiD, 2,8 Turbo V6	<b>F8-7330</b>	
Control Arm-/Trailing Arm Bush	1,8t, 1,8t BioPower, 1,8 i, 1,9 TiD, 1,9 TTiD, 2,0 t, 2,0 t BioPower, 2,0 t BioPower XWD, 2,0 t XWD, 2,0 Turbo Performance, 2,0 Turbo XWD, 2,2 TiD, 2,8 Turbo V6, 2,8 Turbo V6 XWD	<b>F8-7373</b>	d=12; L=52; L1=32; D=45.5
Protective Cap/Bellow, shock absorber	1,8t, 1,8t BioPower, 1,8 i, 1,9 TiD, 1,9 TTiD, 2,0 t, 2,0 t BioPower, 2,0 t XWD, 2,0 Turbo XWD, 2,2 TiD, 2,8 Turbo V6, 2,8 Turbo V6 XWD	<b>F8-7663</b>	H=205
Mounting, automatic transmission	1,9 TiD, 1,9 TTiD	<b>F8-8170</b>	
<b>9-3 Cabriolet (YS3D)</b>		<b>02/1998 → 08/2003</b>	
Dust Cover Kit, shock absorber	2,0 i, 2,0 SE Turbo, 2,0 Turbo, 2,3 i, 2,3 Turbo	<b>AK-735071</b>	
Mounting, stabilizer coupling rod	2,0 i, 2,0 SE Turbo, 2,0 Turbo, 2,3 i, 2,3 Turbo	<b>F8-5333</b>	d=8.5; D=30
Anti-Friction Bearing	All Models	<b>F8-6267</b>	H=12; W=91
Top Strut Mounting	All Models	<b>F8-6327</b>	
Control Arm-/Trailing Arm Bush	All Models	<b>F8-6547</b>	
Sleeve, control arm mounting	All Models	<b>F8-6656</b>	
Engine Mounting	2,0 SE Turbo, 2,0 Turbo	<b>F8-6823</b>	
Engine Mounting	2,3 Turbo	ch.X7051398 → <b>F8-6823</b>	
Engine Mounting	2,0 i, 2,0 Turbo, 2,3 i	<b>F8-6824</b>	
Engine Mounting	2,0 Turbo	B204L; <b>F8-6824</b>	
Mounting, automatic transmission	2,0 i, 2,0 Turbo, 2,3 i	<b>F8-7026</b>	
Mounting, automatic transmission	2,0 Turbo	B204L; <b>F8-7026</b>	
<b>9-3 Convertible (YS3F)</b>		<b>08/2003 →</b>	
Dust Cover Kit, shock absorber	1,8t, 1,9 TiD, 2,0 t, 2,8 Turbo V6	<b>AK-735262</b>	

<b>AK-735071</b>	<b>AK-735262</b>	<b>F5-1079</b>	<b>F5-1102</b>	<b>F8-4090</b>	<b>F8-5333</b>	<b>F8-5639</b>
Ref.Nr.:	Ref.Nr.: 12786062	Ref.Nr.: 1204376	Ref.Nr.: 1204151	Ref.Nr.: 4566899	Ref.Nr.: 2875013	Ref.Nr.: 0614411
<b>F8-6267</b>	<b>F8-6327</b>	<b>F8-6447</b>	<b>F8-6547</b>	<b>F8-6656</b>	<b>F8-6823</b>	<b>F8-6824</b>
Ref.Nr.: 1273747	Ref.Nr.: 5060892	Ref.Nr.: 12786412	Ref.Nr.: 4545711	Ref.Nr.: 4246062	Ref.Nr.: 4283891	Ref.Nr.: 4623153
<b>F8-7026</b>	<b>F8-7172</b>	<b>F8-7329</b>	<b>F8-7330</b>	<b>F8-7373</b>	<b>F8-7663</b>	<b>F8-8170</b>
Ref.Nr.: 4623146	Ref.Nr.: 9191181	Ref.Nr.: 344529	Ref.Nr.: 344537	Ref.Nr.: 24469643	Ref.Nr.: 344435	Ref.Nr.: 9156933

Article Description



Article Nr.

Fitting Position



<b>9-3 Convertible (YS3F)</b>			<b>08/2003 →</b>		
Alternator Freewheel Clutch	1,8t, 1,8t BioPower, 2,0 t, 2,0 t BioPower, 2,0 Turbo Performance		<b>F5-1079</b>		
Alternator Freewheel Clutch	1,9 TiD, 1,9 TTiD		<b>F5-1102</b>		
Control Arm-/Trailing Arm Bush	1,8t, 1,9 TiD, 1,9 TTiD, 2,0 t, 2,0 t BioPower, 2,8 Turbo V6		<b>F8-6447</b>		
Anti-Friction Bearing	1,8t, 1,8t BioPower, 1,9 TiD, 2,0 T, 2,8 Turbo V6		<b>F8-7172</b>		
Top Strut Mounting	1,9 TiD, 2,0 T, 2,8 Turbo V6		<b>F8-7329</b>		
Top Strut Mounting	1,8t, 1,9 TiD, 2,0 T, 2,0 Turbo Performance, 2,8 Turbo V6		<b>F8-7330</b>		
Control Arm-/Trailing Arm Bush	1,8t, 1,8t BioPower, 1,9 TiD, 1,9 TTiD, 2,0 T, 2,0 t BioPower, 2,0 Turbo Performance, 2,8 Turbo V6		<b>F8-7373</b>		d=12; L=52; L1=32; D=45.5
Protective Cap/Bellow, shock absorber	1,8t, 1,8t BioPower, 1,9 TiD, 1,9 TTiD, 2,0 t, 2,0 t BioPower, 2,0 Turbo Performance, 2,8 Turbo V6		<b>F8-7663</b>		H=205
Mounting, automatic transmission	1,9 TiD, 1,9 TTiD		<b>F8-8170</b>		
<b>9-3 Estate (YS3F)</b>			<b>03/2005 →</b>		
Alternator Freewheel Clutch	1,8 t, 1,8 t BioPower, 2,0 t, 2,0 T Bio Power, 2,0 T Bio Power XWD, 2,0 t BioPower, 2,0 t BioPower XWD, 2,0 T XWD		<b>F5-1079</b>		
Alternator Freewheel Clutch	1,9 TiD, 1,9 TTiD		<b>F5-1102</b>		
Control Arm-/Trailing Arm Bush	1,8 i, 1,9 TiD, 1,9 TTiD, 2,0 t, 2,0 t BioPower, 2,0 T XWD, 2,8 Turbo V6, 2,8 Turbo V6 XWD		<b>F8-6447</b>		
Anti-Friction Bearing	1,8 i, 1,8 t, 1,9 TiD, 2,0 T, 2,8 Turbo V6		<b>F8-7172</b>		
Top Strut Mounting	1,8 i, 1,8 t, 1,9 TiD, 2,0 T, 2,8 Turbo V6		<b>F8-7329</b>		
Top Strut Mounting	1,8 i, 1,9 TiD, 2,0 t, 2,8 Turbo V6		<b>F8-7330</b>		
Control Arm-/Trailing Arm Bush	1,8 i, 1,8 t, 1,8 t BioPower, 1,9 TiD, 1,9 TTiD, 2,0 T, 2,0 T Bio Power, 2,0 T Bio Power XWD, 2,0 t BioPower, 2,0 t BioPower XWD, 2,0 T XWD, 2,8 Turbo V6, 2,8 Turbo V6 XWD		<b>F8-7373</b>		d=12; L=52; L1=32; D=45.5
Protective Cap/Bellow, shock absorber	1,8 i, 1,8 t BioPower, 1,9 TiD, 1,9 TTiD, 2,0 t, 2,0 t BioPower, 2,0 T XWD, 2,8 Turbo V6, 2,8 Turbo V6 XWD		<b>F8-7663</b>		H=205
Mounting, automatic transmission	1,9 TiD, 1,9 TTiD		<b>F8-8170</b>		
<b>9-3X</b>			<b>02/2009 →</b>		
Alternator Freewheel Clutch	2,0 T BioPower XWD, 2,0 T XWD		<b>F5-1079</b>		
Alternator Freewheel Clutch	1,9 TTiD		<b>F5-1102</b>		
<b>9-5 (YS3E)</b>			<b>09/1997 → 12/2009</b>		
Dust Cover Kit, shock absorber	1,9 TiD, 2,0, 2,0 t, 2,0 Turbo SE, 2,2 TiD, 2,3 t, 2,3 Turbo, 3,0 TiD, 3,0 V6t		<b>AK-735072</b>		
Dust Cover Kit, shock absorber	1,9 TiD, 2,0, 2,0 t, 2,0 T Biopower, 2,0 Turbo SE, 2,2 TiD, 2,3, 2,3 t, 2,3 Turbo, 3,0 TiD, 3,0 V6t		<b>AK-735263</b>		

<b>AK-735072</b>	<b>AK-735263</b>	<b>F5-1079</b>	<b>F5-1102</b>	<b>F8-4090</b>	<b>F8-6447</b>	<b>F8-7172</b>
Ref.Nr.: 4565180	Ref.Nr.: 12759389	Ref.Nr.: 1204376	Ref.Nr.: 1204151	Ref.Nr.: 4566899	Ref.Nr.: 12786412	Ref.Nr.: 9191181
<b>F8-7329</b>	<b>F8-7330</b>	<b>F8-7373</b>	<b>F8-7663</b>	<b>F8-8170</b>		
Ref.Nr.: 344529	Ref.Nr.: 344537	Ref.Nr.: 24469643	Ref.Nr.: 344435	Ref.Nr.: 9156933		

**Article Description****Article Nr.****Fitting Position**

<b>9-5 (YS3E)</b>			<b>09/1997 → 12/2009</b>		
Control Arm-/Trailing Arm Bush	2.0 t, 2.2 TiD, 2.3 t, 2.3 Turbo, 3.0 TiD, 3.0 V6t		<b>F8-4090</b>		H1=50; H2=59; d=12; D1=36; D2=43
Control Arm-/Trailing Arm Bush	All Models		<b>F8-5201</b>		d=12; D=45; W=52
Belt Pulley, crankshaft	2.2 TiD, 3.0 TiD		<b>F8-5639</b>		
Control Arm-/Trailing Arm Bush	1.9 TiD, 2.0, 2.0 t, 2.0 T Biopower, 2.0 Turbo SE, 2.2 TiD, 2.3, 2.3 t, 2.3 t BioPower, 2.3 Turbo, 3.0 TiD, 3.0 V6t		<b>F8-6098</b>		H=55; d=12; D=60
Anti-Friction Bearing	2.0, 2.0 t, 2.0 Turbo SE, 2.2 TiD, 2.3 t, 2.3 Turbo, 3.0 TiD, 3.0 V6t		<b>F8-6267</b>		H=12; W=91
Engine Mounting	2.0 t, 2.3 t, 2.3 Turbo		<b>F8-6830</b>		
Engine Mounting	3.0 V6t		<b>F8-6831</b>		
Engine Mounting	1.9 TiD, 2.2 TiD, 3.0 TiD		<b>F8-7884</b>		
Engine Mounting	2.0 t, 2.3 t, 2.3 Turbo	ch.→33040606; 01/2002 →	<b>F8-7887</b>		
Engine Mounting	2.0 t, 2.3 t, 2.3 Turbo	ch.Y3000145→;	<b>F8-7887</b>		
Engine Mounting	2.0 t, 2.3 t, 2.3 Turbo		<b>F8-7887</b>		
Engine Mounting	2.3 Turbo	ch.→33040606	<b>F8-7887</b>		
Engine Mounting	2.0 t, 2.2 TiD, 2.3 t, 2.3 Turbo, 3.0 TiD, 3.0 V6t		<b>F8-7888</b>		
<b>9-5 Estate (YS3E)</b>			<b>10/1998 → 12/2009</b>		
Dust Cover Kit, shock absorber	2.0, 2.0 t, 2.2 TiD, 2.3 t, 2.3 Turbo, 3.0 TiD, 3.0 V6t		<b>AK-735072</b>		
Dust Cover Kit, shock absorber	1.9 TiD, 2.0, 2.0 t, 2.0 t Biopower, 2.2 TiD, 2.3, 2.3 t, 2.3 Turbo, 3.0 TiD, 3.0 V6t		<b>AK-735263</b>		
Control Arm-/Trailing Arm Bush	2.0 t, 2.2 TiD, 2.3 t, 2.3 Turbo, 3.0 TiD, 3.0 V6t		<b>F8-4090</b>		H1=50; H2=59; d=12; D1=36; D2=43
Control Arm-/Trailing Arm Bush	All Models		<b>F8-5201</b>		d=12; D=45; W=52
Belt Pulley, crankshaft	2.2 TiD, 3.0 TiD		<b>F8-5639</b>		
Control Arm-/Trailing Arm Bush	1.9 TiD, 2.0, 2.0 t, 2.0 t Biopower, 2.2 TiD, 2.3, 2.3 t, 2.3 t BioPower, 2.3 Turbo, 3.0 TiD, 3.0 V6t		<b>F8-6098</b>		H=55; d=12; D=60
Anti-Friction Bearing	2.0 t, 2.2 TiD, 2.3, 2.3 t, 2.3 Turbo, 3.0 TiD, 3.0 V6t		<b>F8-6267</b>		H=12; W=91
Engine Mounting	2.0 t, 2.3 t, 2.3 Turbo		<b>F8-6830</b>		
Engine Mounting	3.0 V6t		<b>F8-6831</b>		
Engine Mounting	1.9 TiD, 2.2 TiD, 3.0 TiD		<b>F8-7884</b>		
Engine Mounting	2.0 t, 2.3 t, 2.3 Turbo	ch.→33040606; 01/2002 →	<b>F8-7887</b>		
Engine Mounting	2.0 t, 2.3 t, 2.3 Turbo	ch.Y3000145→;	<b>F8-7887</b>		
Engine Mounting	2.0 t, 2.3 t, 2.3 Turbo		<b>F8-7887</b>		
Engine Mounting	2.3 Turbo	ch.→33040606	<b>F8-7887</b>		
Engine Mounting	2.0 t, 2.2 TiD, 2.3 t, 2.3 Turbo, 3.0 TiD, 3.0 V6t		<b>F8-7888</b>		

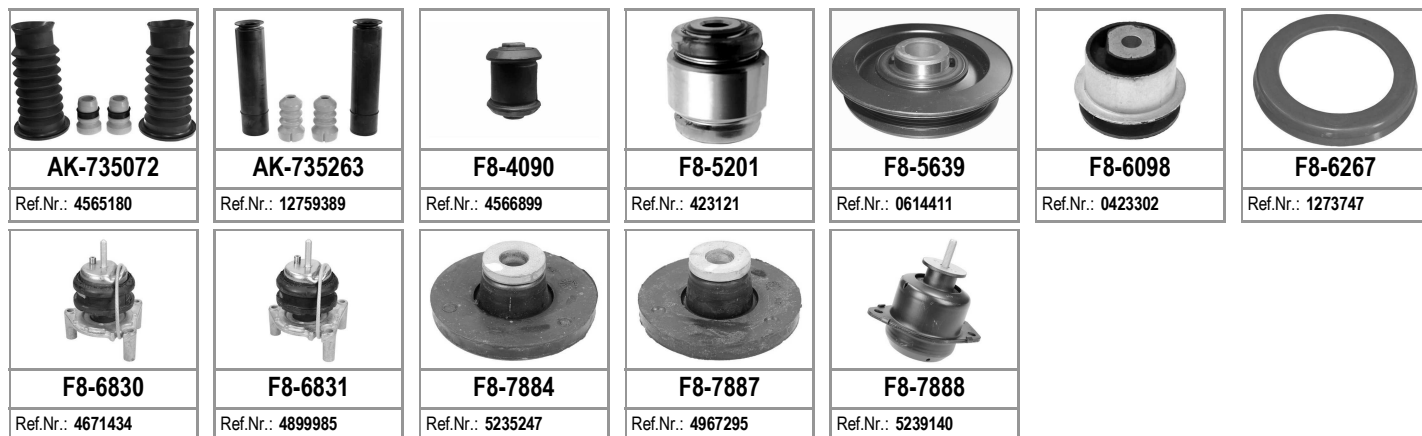

Article Description			Article Nr.	Fitting Position	
<b>9-5 (YS3G)</b>					<b>05/2010 → 01/2012</b>
Dust Cover Kit, shock absorber	All Models	▲, SP, ST	<b>AK-735434</b>		
Top Strut Mounting	All Models	▲, ▲, SP, ST	<b>F8-7611</b>	⊕ ⊕	
Top Strut Mounting	All Models	▲, ▲, SP, ST	<b>F8-7612</b>	⊕	
Top Strut Mounting	All Models	▲, ▲, SP, ST	<b>F8-7613</b>	⊕	
Rubber Buffer, suspension	2.0 T BioPower XWD, 2.0 T XWD, 2.0 TTID XWD, 2.8 T V6 XWD	▲	<b>F8-7615</b>	⊕ ⊕	
Rubber Buffer, suspension	1.6 T, 2.0 T, 2.0 T BioPower, 2.0 TiD, 2.0 TTID		<b>F8-7889</b>	⊕ ⊕	
<b>9-5 [USA] Estate</b>					<b>01/1999 → 12/2006</b>
Control Arm-/Trailing Arm Bush	2.3, 3.0		<b>F8-6098</b>	⊕ ⊕	H=55; d=12; D=60
<b>9-5 [USA] Saloon</b>					<b>01/1999 → 12/2006</b>
Control Arm-/Trailing Arm Bush	All Models		<b>F8-6098</b>	⊕ ⊕	H=55; d=12; D=60

<b>AK-735434</b>	<b>F8-6098</b>	<b>F8-7611</b>	<b>F8-7612</b>	<b>F8-7613</b>	<b>F8-7615</b>	<b>F8-7889</b>
Ref.Nr.: 13243574	Ref.Nr.: 0423302	Ref.Nr.: 0344469	Ref.Nr.: 436426	Ref.Nr.: 436427	Ref.Nr.: 436503	Ref.Nr.: 436504



**Article Description****Article Nr.****Fitting Position**

128				01/1976 → 12/1980	
Repair Kit, wheel suspension	1.2		<b>F8-6275</b>		
Control Arm-/Trailing Arm Bush	All Models		<b>G9-506</b>		H=37; d=9,2; D1=25; D2=36
<b>ALHAMBRA (7V8, 7V9)</b>				04/1996 → 03/2010	
Dust Cover Kit, shock absorber	All Models		<b>AK-735034</b>		
Alternator Freewheel Clutch	All Models		<b>F5-1004</b>		
Alternator Freewheel Clutch	1.9 TDI, 2.0 i		<b>F5-1007</b>		
Alternator Freewheel Clutch	1.8 T 20V		<b>F5-1009</b>		
Top Strut Mounting	1.8 T 20V, 1.9 TDI, 1.9 TDI 4motion, 2.0 i, 2.0 TDI, 2.8 V6, 2.8 V6 4motion		<b>F8-1034</b>		H=50; d=27; D=98
Top Strut Mounting	1.8 T 20V, 1.9 TDI, 1.9 TDI 4motion, 2.0 i, 2.0 TDI, 2.8 V6, 2.8 V6 4motion		<b>F8-1034S</b>		H=51; d=14; D=96
Anti-Friction Bearing	All Models		<b>F8-3039</b>		H=14; d1=14; D=45
Bellow, steering	1.8 T 20V, 1.9 TDI, 2.0 i, 2.8 V6, 2.8 V6 4motion		<b>F8-5051</b>		H=180; d1=10; d2=49
Stabiliser Mounting	1.8 T 20V, 1.9 TDI, 2.0 i, 2.8 V6 4motion		<b>F8-5407</b>		d=17
Mounting, axle beam	1.8 T 20V, 1.9 TDI, 2.0 i, 2.8 V6		<b>F8-5530</b>		
Belt Pulley, crankshaft	1.9 TDI	Number of Ribs: 5; Parameter: 6PK	<b>F8-5649</b>		H=31.5; d=30.02; Mounting points diam.[mm]=8.5; D1=161.5; D2=160.5
Belt Pulley, crankshaft	1.8 T 20V, 2.0 i		<b>F8-5650</b>		
Rubber Buffer, suspension	1.8 T 20V, 1.9 TDI, 1.9 TDI 4motion, 2.0 i, 2.0 TDI, 2.8 V6, 2.8 V6 4motion	for OE: 1BA, 1BH, 1BJ, 1BR;	<b>F8-5995</b>		H=83
Belt Pulley, crankshaft	1.9 TDI	ch.→7M-4-507000; 01/2001 →; Number of Ribs: 5; Parameter: 6PK	<b>F8-6392</b>		H=47; d=30; D=143
Belt Pulley, crankshaft	1.9 TDI, 1.9 TDI 4motion	ch.→7M-4-507000; Number of Ribs: 5; Parameter: 6PK	<b>F8-6392</b>		H=47; d=30; D=143
Stabiliser Mounting	1.8 T 20V, 1.9 TDI, 1.9 TDI 4motion, 2.0 i, 2.0 TDI, 2.8 V6, 2.8 V6 4motion		<b>F8-6702</b>		d=20.6
Stabiliser Mounting	All Models		<b>F8-6703</b>		H=29; d=21
Engine Mounting	2.8 V6, 2.8 V6 4motion		<b>F8-7032</b>		
Mounting, manual transmission	2.0 i	06/2000 →;	<b>F8-7049</b>		
Protective Cap/Bellow, shock absorber	All Models		<b>F8-7688</b>		H=220
Engine Mounting	1.9 TDI		<b>F8-8150</b>		
Control Arm-/Trailing Arm Bush	1.8 T 20V, 1.9 TDI, 1.9 TDI 4motion, 2.0 i, 2.8 V6, 2.8 V6 4motion		<b>G9-664</b>		H=50; d=18; D=60
Control Arm-/Trailing Arm Bush	1.8 T 20V, 1.9 TDI, 1.9 TDI 4motion, 2.0 i, 2.8 V6, 2.8 V6 4motion		<b>G9-665</b>		H=60; d=14; D1=35; D2=38
Bellow, steering	All Models	with clamps;	<b>LM-10023S</b>		d1=10; d2=49; L [mm]=180
Bellow Set, drive shaft	1.8 T 20V	06/2000 →;  AWC; with clamps;	<b>MK-810160</b>		L=116

<b>AK-735034</b>	<b>F5-1004</b>	<b>F5-1007</b>	<b>F5-1009</b>	<b>F8-1034</b>	<b>F8-1034S</b>	<b>F8-3039</b>
Ref.Nr.:	Ref.Nr.: 038903119T	Ref.Nr.: 028903119AQ	Ref.Nr.: 038903119	Ref.Nr.: 357412331A	Ref.Nr.: 7201848S1	Ref.Nr.: 357412249A
<b>F8-5051</b>	<b>F8-5407</b>	<b>F8-5530</b>	<b>F8-5649</b>	<b>F8-5650</b>	<b>F8-5995</b>	<b>F8-6275</b>
Ref.Nr.: 7398680	Ref.Nr.: 7200957	Ref.Nr.: 95VW5K818BC	Ref.Nr.: 028105243T	Ref.Nr.: 06A105243E	Ref.Nr.: 1011898	Ref.Nr.: 5174.07
<b>F8-6392</b>	<b>F8-6702</b>	<b>F8-6703</b>	<b>F8-7032</b>	<b>F8-7049</b>	<b>F8-7688</b>	<b>F8-8150</b>
Ref.Nr.: 038105243	Ref.Nr.: 7M0511413A	Ref.Nr.: 7M0511414B	Ref.Nr.: 1118741	Ref.Nr.: 7M3399201H	Ref.Nr.: 7M0413175A	Ref.Nr.: 1089033

Article Description



Article Nr.

Fitting Position



<b>ALHAMBRA (7V8, 7V9)</b>			<b>04/1996 → 03/2010</b>		
Bellow Set, drive shaft	1.9 TDI	06/2000 →;  ANU; with clamps	<b>MK-810160</b>		L=116
Bellow Set, drive shaft	1.9 TDI	ch.→7M-3-525800; with clamps	<b>MK-810160</b>		L=116
Bellow Set, drive shaft	1.9 TDI, 1.9 TDI 4motion, 2.8 V6 4motion	with clamps	<b>MK-810160</b>		L=116
Bellow Set, drive shaft	2.0 i	ADY; with clamps;	<b>MK-810160</b>		L=116
Bellow Set, drive shaft	2.8 V6	with clamps;	<b>MK-810160</b>		L=116
<b>ALHAMBRA (710, 711)</b>			<b>06/2010 → 05/2011</b>		
Alternator Freewheel Clutch	2.0 TDI, 2.0 TDI All-wheel Drive		<b>F5-1004</b>		
Alternator Freewheel Clutch	1.8 TFSI, 2.0 TSI		<b>F5-1044</b>		
Alternator Freewheel Clutch	1.4 TSI		<b>F5-1064</b>		
Control Arm-/Trailing Arm Bush	1.4 TSI, 2.0 TDI, 2.0 TDI All-wheel Drive, 2.0 TSI		<b>F8-5633</b>	⊕ ⊕	
Protective Cap/Bellow, shock absorber	1.4 TSI, 2.0 TDI, 2.0 TDI All-wheel Drive, 2.0 TSI	for OE: 1JA, 1JC;	<b>F8-6044</b>	⊕ ⊕	H=160
Protective Cap/Bellow, shock absorber	1.8 TFSI, 2.0 TDI		<b>F8-6044</b>	⊕ ⊕	H=160
Belt Pulley, crankshaft	2.0 TDI, 2.0 TDI All-wheel Drive	Number of Ribs: 5; Parameter: 6PK	<b>F8-6572</b>		
Control Arm-/Trailing Arm Bush	1.4 TSI, 2.0 TDI, 2.0 TDI All-wheel Drive, 2.0 TSI	Aluminium; not for special purpose vehicles	<b>F8-6701</b>	⊕ ⊕ ↓	
Control Arm-/Trailing Arm Bush	1.4 TSI, 2.0 TDI, 2.0 TDI All-wheel Drive, 2.0 TSI	not for special purpose vehicles	<b>F8-6736</b>	⊕ ⊕	
Rubber Buffer, suspension	1.4 TSI, 2.0 TDI, 2.0 TDI All-wheel Drive, 2.0 TSI	for OE: G03;	<b>F8-7131</b>	⊕ ⊕	H=70
Protective Cap/Bellow, shock absorber	1.4 TSI, 2.0 TDI, 2.0 TDI All-wheel Drive, 2.0 TSI		<b>F8-7132</b>	⊕ ⊕	H=190
Rubber Buffer, suspension	1.4 TSI, 1.8 TFSI, 2.0 TDI, 2.0 TDI All-wheel Drive, 2.0 TSI	for OE: G02;	<b>F8-7174</b>	⊕ ⊕	H=80
Top Strut Mounting	1.4 TSI, 1.8 TFSI, 2.0 TDI, 2.0 TDI All-wheel Drive, 2.0 TSI	for OE: 1JC, F0A+1JA;	<b>F8-7603</b>	⊕ ⊕	
Top Strut Mounting	1.4 TSI, 1.8 TFSI, 2.0 TDI, 2.0 TDI All-wheel Drive, 2.0 TSI	for OE: F4E+1JA, F4F+1JA, F5Z+1JA;	<b>F8-7603</b>	⊕ ⊕	
Rubber Buffer, suspension	1.4 TSI, 2.0 TDI, 2.0 TDI All-wheel Drive, 2.0 TSI	for OE: 1JA;	<b>F8-7815</b>	⊕ ⊕	H=153
Rubber Buffer, suspension	1.4 TSI, 2.0 TDI, 2.0 TDI All-wheel Drive, 2.0 TSI	for OE: 1JC;	<b>F8-7816</b>	⊕ ⊕	H=138
Protective Cap/Bellow, shock absorber	1.4 TSI, 1.8 TFSI, 2.0 TDI, 2.0 TDI All-wheel Drive, 2.0 TSI	for OE: 1JA, 1JC, F4E, F4F, F5Z;  ;	<b>F8-7845</b>	⊕ ⊕	
Belt Pulley, crankshaft	2.0 TSI	Number of Ribs: 5; Parameter: 6PK	<b>F8-7880</b>		D=143
Control Arm-/Trailing Arm Bush	1.4 TSI, 2.0 TDI, 2.0 TSI		<b>F8-7909</b>	↓	
Engine Mounting	1.4 TSI, 1.8 TFSI, 2.0 TDI, 2.0 TDI All-wheel Drive, 2.0 TSI		<b>F8-7982</b>	↑	

<b>AK-735264</b>	<b>F5-1004</b>	<b>F5-1044</b>	<b>F5-1064</b>	<b>F8-5633</b>	<b>F8-6044</b>	<b>F8-6572</b>
Ref.Nr.: 6N0413175A	Ref.Nr.: 038903119T	Ref.Nr.: 06B903119B	Ref.Nr.: 03C903119D	Ref.Nr.: 1K0407182A	Ref.Nr.: 3C0513425	Ref.Nr.: 038105243L
<b>F8-6701</b>	<b>F8-6736</b>	<b>F8-7131</b>	<b>F8-7132</b>	<b>F8-7174</b>	<b>F8-7603</b>	<b>F8-7815</b>
Ref.Nr.: 3C0199231A	Ref.Nr.: 1K0407183A	Ref.Nr.: 1K0412303B	Ref.Nr.: 6N0413175A	Ref.Nr.: 1K0412303M	Ref.Nr.: 3C0513353	Ref.Nr.: 7N0511359
<b>F8-7816</b>	<b>F8-7845</b>	<b>F8-7880</b>	<b>F8-7909</b>	<b>F8-7982</b>	<b>MK-810160</b>	
Ref.Nr.: 7N0511359A	Ref.Nr.: 3C0513425B	Ref.Nr.: 06H105243F	Ref.Nr.: 1K0505553 A	Ref.Nr.: 1K0199868Q	Ref.Nr.: 3D0 498 201	

**Article Description****Article Nr.****Fitting Position****ALTEA (5P1)**

03/2004 → 05/2009

Dust Cover Kit, shock absorber	1.6, 1.8 TFSI, 1.9 TDI, 2.0 FSI, 2.0 TDI, 2.0 TDI 16V, 2.0 TFSI		AK-735264				
Dust Cover Kit, shock absorber	1.6, 1.8 TFSI, 1.9 TDI, 2.0 FSI, 2.0 TDI, 2.0 TDI 16V, 2.0 TFSI		AK-735265				
Alternator Freewheel Clutch	1.4 TSI, 1.6, 1.6 LPG, 1.6 TDI, 1.9 TDI, 2.0 FSI, 2.0 TDI, 2.0 TDI 16V, 2.0 TFSI		F5-1004				
Alternator Freewheel Clutch	1.8 TFSI		F5-1044				
Alternator Freewheel Clutch	1.2 TSI, 1.4 TSI		F5-1064				
Control Arm-/Trailing Arm Bush	All Models		F8-5633				
Belt Pulley, crankshaft	2.0 FSI		F8-5650				
Top Strut Mounting	All Models		F8-6284				
Top Strut Mounting	1.2 TSI, 1.4 16V, 1.4 TSI, 1.6, 1.6 LPG, 1.6 TDI, 1.8 TFSI, 1.9 TDI, 2.0 FSI, 2.0 TDI, 2.0 TDI 16V, 2.0 TFSI	for OE: 1JA;	F8-6348				
Top Strut Mounting	1.2 TSI, 1.4 16V, 1.4 TSI, 1.6, 1.6 LPG, 1.6 TDI, 1.8 TFSI, 1.9 TDI, 2.0 FSI, 2.0 TDI, 2.0 TDI 16V, 2.0 TFSI	for OE: 1JC, UC2, UC3, UC4;	F8-6348				
Top Strut Mounting	1.4 16V, 1.4 TSI, 1.6, 1.8 TFSI, 1.9 TDI, 2.0 FSI, 2.0 TDI, 2.0 TDI 16V, 2.0 TFSI	for OE: UC0;	F8-6349				
Belt Pulley, crankshaft	1.9 TDI, 2.0 TDI, 2.0 TDI 16V	Number of Ribs: 5; Parameter: 6PK	F8-6396				H=41.6; d=30; Mounting points diam.[mm]=7, 8.6; D=139.7
Control Arm-/Trailing Arm Bush	1.6, 1.9 TDI, 2.0 FSI, 2.0 TDI, 2.0 TDI 16V, 2.0 TFSI	Aluminium	F8-6424				
Control Arm-/Trailing Arm Bush	1.6, 1.9 TDI, 2.0 FSI, 2.0 TDI, 2.0 TDI 16V, 2.0 TFSI	Aluminium	F8-6425				
Control Arm-/Trailing Arm Bush	1.4 16V, 1.4 TSI, 1.6, 1.8 TFSI, 1.9 TDI, 2.0 FSI, 2.0 TDI, 2.0 TDI 16V, 2.0 TFSI		F8-6463				H=64; d=12; D=60
Engine Mounting	2.0 TDI		F8-6528				
Engine Mounting	2.0 TDI, 2.0 TDI 16V		F8-6528				
Engine Mounting	1.4 16V		F8-6531				H=117.7; L=165; W=149
Anti-Friction Bearing	All Models		F8-6569				
Top Strut Mounting	All Models		F8-6570				
Belt Pulley, crankshaft	1.6 TDI	Number of Ribs: 5; Parameter: 6PK	F8-6572				
Belt Pulley, crankshaft	2.0 TDI 16V		F8-6572				
Engine Mounting	1.6		F8-6988				
Engine Mounting	1.8 TFSI, 2.0 FSI, 2.0 TFSI		F8-6989				
Rubber Buffer, suspension	1.2 TSI, 1.4 16V, 1.4 TSI, 1.6, 1.6 LPG, 1.6 TDI, 1.8 TFSI, 1.9 TDI, 2.0 FSI, 2.0 TDI, 2.0 TDI 16V, 2.0 TFSI	for OE: G02, G07, G52, G53, G54, G55	F8-7131				H=70
Rubber Buffer, suspension	1.6, 1.6 TDI, 2.0 TDI 16V	for OE: G02, G07, G39, G40, G52, G53, G54, G55	F8-7131				H=70
Protective Cap/Bellow, shock absorber	All Models		F8-7132				H=190

<b>AK-735264</b>	<b>AK-735265</b>	<b>F5-1004</b>	<b>F5-1044</b>	<b>F5-1064</b>	<b>F8-5633</b>	<b>F8-5650</b>
Ref.Nr.: 6N0413175A	Ref.Nr.: 1K0511353Q	Ref.Nr.: 038903119T	Ref.Nr.: 06B903119B	Ref.Nr.: 03C903119D	Ref.Nr.: 1K0407182A	Ref.Nr.: 06A105243E
<b>F8-6284</b>	<b>F8-6348</b>	<b>F8-6349</b>	<b>F8-6396</b>	<b>F8-6424</b>	<b>F8-6425</b>	<b>F8-6463</b>
Ref.Nr.: 6N0412249C	Ref.Nr.: 1K0513353G	Ref.Nr.: 1K0513353H	Ref.Nr.: 03G105243	Ref.Nr.: 1K0199232G	Ref.Nr.: 1K0199231J	Ref.Nr.: 1K0505541B
<b>F8-6528</b>	<b>F8-6531</b>	<b>F8-6569</b>	<b>F8-6570</b>	<b>F8-6572</b>	<b>F8-6988</b>	<b>F8-6989</b>
Ref.Nr.: 1K0 199 262 AT	Ref.Nr.: 1K0199262T	Ref.Nr.: 6N0412249C	Ref.Nr.: 1K0412331C	Ref.Nr.: 038105243L	Ref.Nr.: 1K0199262AL	Ref.Nr.: 1K0199262AM

Article Description



Article Nr.

Fitting Position



ALTEA (5P1)		03/2004 → 05/2009			
Rubber Buffer, suspension	All Models	for OE: UC0; Shape Oval; <b>ST</b>	<b>F8-7579</b>		H=100
Rubber Buffer, suspension	All Models	for OE: 1JA, 1JC, 1JU, 1JV; <b>SP, ST</b>	<b>F8-7580</b>		H=101
Rubber Buffer, suspension	All Models	for OE: UC2, UC3; Shape Round; <b>SP</b>	<b>F8-7601</b>		H=118
Top Strut Mounting	1.2 TSI, 1.6 LPG, 1.6 TDI, 1.9 TDI	for OE: UC0; <b>ST</b>	<b>F8-7603</b>		
Top Strut Mounting	1.4 16V, 1.4 TSI, 1.6, 1.8 TFSI, 1.9 TDI, 2.0 TDI, 2.0 TDI 16V	07/2009 →; for OE: UC0; <b>ST</b>	<b>F8-7603</b>		
Protective Cap/Bellow, shock absorber	All Models	for OE: 1JA, 1JC, 1JV, UC0, UC2, UC3, UC4; <b>SP, ST</b>	<b>F8-7640</b>		H=176
Rubber Buffer, suspension	All Models	for OE: G07, G40, G42, G66; <b>SP</b>	<b>F8-7697</b>		H=55
Rubber Buffer, suspension	All Models	for OE: G02, G39, G41	<b>F8-7809</b>		H=55
Rubber Buffer, suspension	1.2 TSI, 1.4 16V, 1.4 TSI, 1.6, 1.6 LPG, 1.6 TDI, 1.8 TFSI, 1.9 TDI, 2.0 TDI, 2.0 TDI 16V	for OE: G50, G69	<b>F8-7834</b>		H=90
Rubber Buffer, suspension	All Models	for OE: UC0; Shape Round; <b>ST</b>	<b>F8-7835</b>		H=75
Belt Pulley, crankshaft	1.8 TFSI	Number of Ribs: 5; Parameter: 6PK	<b>F8-7880</b>		D=143
Control Arm-/Trailing Arm Bush	All Models		<b>F8-7902</b>		H=60; d=12; D=42
Control Arm-/Trailing Arm Bush	All Models		<b>F8-7907</b>		H=45; d=14; D=38
Control Arm-/Trailing Arm Bush	All Models		<b>F8-7908</b>		H=45; d=12; D=38
Control Arm-/Trailing Arm Bush	All Models		<b>F8-7909</b>		
Stabiliser Mounting	1.4 16V, 1.4 TSI, 1.6, 1.6 TDI, 1.8 TFSI, 1.9 TDI, 2.0 FSI, 2.0 TDI, 2.0 TDI 16V, 2.0 TFSI		<b>F8-7923</b>		d=20,7
Stabiliser Mounting	1.6, 1.9 TDI, 2.0 FSI, 2.0 TDI, 2.0 TDI 16V, 2.0 TFSI		<b>F8-7930</b>		d=18,5
Engine Mounting	1.9 TDI		<b>F8-7958</b>		
Engine Mounting	1.4 TSI		<b>F8-7959</b>		
Engine Mounting	1.4 16V, 1.4 TSI, 1.6, 1.6 LPG		<b>F8-7960</b>		
Engine Mounting	1.8 TFSI	CDAA	<b>F8-7961</b>		
Engine Mounting	2.0 FSI	6-speed	<b>F8-7961</b>		
Engine Mounting	1.9 TDI	BLS, BXE; Transmission Type: DSG	<b>F8-7962</b>		
Engine Mounting	2.0 TDI, 2.0 TDI 16V	Transmission Type: DSG	<b>F8-7962</b>		
Engine Mounting	2.0 TFSI	6-speed	<b>F8-7962</b>		
Engine Mounting	1.2 TSI, 1.4 16V, 1.4 TSI, 1.6, 1.6 LPG		<b>F8-7965</b>		
Engine Mounting	1.9 TDI, 2.0 FSI, 2.0 TDI, 2.0 TDI 16V		<b>F8-7966</b>		
Engine Mounting	1.4 16V, 1.4 TSI, 2.0 TFSI		<b>F8-7981</b>		
Engine Mounting	1.6	BGU, BSE, BSF	<b>F8-7981</b>		
Engine Mounting	1.6	BSF;	<b>F8-7981</b>		

<b>F8-7579</b>	<b>F8-7580</b>	<b>F8-7601</b>	<b>F8-7603</b>	<b>F8-7640</b>	<b>F8-7697</b>	<b>F8-7809</b>
Ref.Nr.: 1K0 511 353 J	Ref.Nr.: 1K0 511 353 Q	Ref.Nr.: 1K0511353N	Ref.Nr.: 3C0513353	Ref.Nr.: 1K0513425A	Ref.Nr.: 1K0412303F	Ref.Nr.: 1K0412303E
<b>F8-7834</b>	<b>F8-7835</b>	<b>F8-7880</b>	<b>F8-7902</b>	<b>F8-7907</b>	<b>F8-7908</b>	<b>F8-7909</b>
Ref.Nr.: 1K0412303H	Ref.Nr.: 1K0511353S	Ref.Nr.: 06H105243F	Ref.Nr.: 1K0505171C	Ref.Nr.: 1K0505203A	Ref.Nr.: 1K0505279A	Ref.Nr.: 1K0505553 A
<b>F8-7923</b>	<b>F8-7930</b>	<b>F8-7958</b>	<b>F8-7959</b>	<b>F8-7960</b>	<b>F8-7961</b>	<b>F8-7962</b>
Ref.Nr.: 1K0511327AR	Ref.Nr.: 1K0511327AP	Ref.Nr.: 1K0199262AS	Ref.Nr.: 1K0199262CG	Ref.Nr.: 1K0199555L	Ref.Nr.: 1K0199555N	Ref.Nr.: 1K0199555Q

**Article Description****Article Nr.****Fitting Position**

<b>ALTEA (5P1)</b>				<b>03/2004 → 05/2009</b>	
Engine Mounting	1.8 TFSI	BYT, BZB	<b>F8-7981</b>	↓	
Engine Mounting	1.9 TDI, 2.0 TDI	ch.→5P-8-032600	<b>F8-7981</b>	↓	
Engine Mounting	2.0 FSI		<b>F8-7981</b>	↓	
Engine Mounting	2.0 FSI	BVY, BVZ;	<b>F8-7981</b>	↓	
Engine Mounting	2.0 TDI	BMN	<b>F8-7981</b>	↓	
Engine Mounting	2.0 TDI 16V	ch.→5P-8-032600;  BKD	<b>F8-7981</b>	↓	
Engine Mounting	2.0 TDI 16V	BKD	<b>F8-7981</b>	↓	
Engine Mounting	1.2 TSI, 1.4 TSI, 1.6, 1.6 LPG, 1.6 TDI, 1.8 TFSI, 1.9 TDI, 2.0 FSI, 2.0 TDI, 2.0 TFSI		<b>F8-7982</b>	↑	
Engine Mounting	1.4 16V	BXW	<b>F8-7982</b>	↑	
Engine Mounting	1.9 TDI	BLS, BXE	<b>F8-7982</b>	↑	
Engine Mounting	2.0 TDI 16V	CFHC	<b>F8-7982</b>	↑	
Control Arm-/Trailing Arm Bush	1.2 TSI, 1.4 TSI, 1.6 LPG, 1.6 TDI, 1.8 TFSI, 1.9 TDI, 2.0 TDI, 2.0 TDI 16V, 2.0 TFSI		<b>F8-7991</b>		
Engine Mounting	2.0 TDI, 2.0 TDI 16V		<b>F8-8152</b>	⊕	
<b>ALTEA XL (5P5, 5P8)</b>				<b>10/2006 → 05/2009</b>	
Alternator Freewheel Clutch	1.4 TSI, 1.6, 1.6 LPG, 1.6 Multifuel, 1.6 TDI, 1.9 TDI, 2.0 TDI, 2.0 TDI 16V, 2.0 TDI 4x4, 2.0 TFSI 4x4		<b>F5-1004</b>		
Alternator Freewheel Clutch	1.8 TFSI, 2.0 TFSI 4x4		<b>F5-1044</b>		
Alternator Freewheel Clutch	1.2 TSI, 1.4 TSI		<b>F5-1064</b>		
Control Arm-/Trailing Arm Bush	1.2 TSI, 1.4 16V, 1.4 TSI, 1.6, 1.6 LPG, 1.6 Multifuel, 1.6 TDI, 1.8 TFSI, 1.9 TDI, 2.0 FSI, 2.0 TDI, 2.0 TDI 16V, 2.0 TDI 4x4, 2.0 TFSI 4x4		<b>F8-5633</b>	⊕ ⊕	
Belt Pulley, crankshaft	2.0 FSI		<b>F8-5650</b>		
Top Strut Mounting	1.2 TSI, 1.4 16V, 1.4 TSI, 1.6, 1.6 LPG, 1.6 Multifuel, 1.6 TDI, 1.8 TFSI, 1.9 TDI, 2.0 FSI, 2.0 TDI, 2.0 TDI 16V, 2.0 TDI 4x4, 2.0 TFSI, 2.0 TFSI 4x4		<b>F8-6284</b>		
Top Strut Mounting	1.2 TSI, 1.4 16V, 1.4 TSI, 1.6, 1.6 LPG, 1.6 Multifuel, 1.6 TDI, 1.8 TFSI, 1.9 TDI, 2.0 FSI, 2.0 TDI, 2.0 TDI 16V, 2.0 TFSI	for OE: 1JA;	<b>F8-6348</b>		
Top Strut Mounting	1.2 TSI, 1.4 16V, 1.4 TSI, 1.6, 1.6 LPG, 1.6 Multifuel, 1.6 TDI, 1.8 TFSI, 1.9 TDI, 2.0 FSI, 2.0 TDI, 2.0 TDI 16V, 2.0 TFSI	for OE: 1JC, UC2, UC3, UC4;	<b>F8-6348</b>		
Top Strut Mounting	2.0 TDI 16V 4x4, 2.0 TDI 4x4, 2.0 TFSI 4x4	for OE: 1JU;	<b>F8-6348</b>		
Top Strut Mounting	2.0 TDI 16V 4x4, 2.0 TDI 4x4, 2.0 TFSI 4x4	for OE: 1JV;	<b>F8-6348</b>		
Top Strut Mounting	1.4 16V, 1.4 TSI, 1.6, 1.6 Multifuel, 1.8 TFSI, 1.9 TDI, 2.0 FSI, 2.0 TDI, 2.0 TDI 16V, 2.0 TDI 4x4, 2.0 TFSI, 2.0 TFSI 4x4	for OE: UC0;	<b>F8-6349</b>	⊕ ⊕	
Belt Pulley, crankshaft	1.9 TDI, 2.0 TDI, 2.0 TDI 16V	Number of Ribs: 5; Parameter: 6PK	<b>F8-6396</b>		H=41.6; d=30; Mounting points diam.[mm]=7, 8.6; D=139.7

<b>F5-1004</b>	<b>F5-1044</b>	<b>F5-1064</b>	<b>F8-5633</b>	<b>F8-5650</b>	<b>F8-6284</b>	<b>F8-6348</b>
Ref.Nr.: 038903119T	Ref.Nr.: 06B903119B	Ref.Nr.: 03C903119D	Ref.Nr.: 1K0407182A	Ref.Nr.: 06A105243E	Ref.Nr.: 6N0412249C	Ref.Nr.: 1K0513353G
<b>F8-6349</b>	<b>F8-6396</b>	<b>F8-6424</b>	<b>F8-7981</b>	<b>F8-7982</b>	<b>F8-7991</b>	<b>F8-8152</b>
Ref.Nr.: 1K0513353H	Ref.Nr.: 03G105243	Ref.Nr.: 1K0199232G	Ref.Nr.: 1K0199867Q	Ref.Nr.: 1K0199868Q	Ref.Nr.: 1K0407183G	Ref.Nr.: 1K0199555T

Article Description

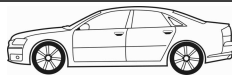

Article Nr.

Fitting Position



## ALTEA XL (5P5, 5P8)

10/2006 → 05/2009

Control Arm-/Trailing Arm Bush	2.0 TDI 4x4	Aluminium	<b>F8-6424</b>		
Control Arm-/Trailing Arm Bush	2.0 TDI 4x4	Aluminium	<b>F8-6425</b>		
Control Arm-/Trailing Arm Bush	1.4 16V, 1.4 TSI, 1.6, 1.8 TFSI, 1.9 TDI, 2.0 FSI, 2.0 TDI, 2.0 TDI 16V, 2.0 TDI 4x4, 2.0 TFSI 4x4		<b>F8-6463</b>		H=64; d=12; D=60
Engine Mounting	2.0 TDI 16V	BKD	<b>F8-6528</b>		
Engine Mounting	2.0 TDI, 2.0 TDI 4x4		<b>F8-6528</b>		
Engine Mounting	1.4 16V		<b>F8-6531</b>		H=117.7; L=165; W=149
Anti-Friction Bearing	1.2 TSI, 1.4 16V, 1.4 TSI, 1.6, 1.6 LPG, 1.6 Multifuel, 1.6 TDI, 1.8 TFSI, 1.9 TDI, 2.0 FSI, 2.0 TDI, 2.0 TDI 16V, 2.0 TDI 4x4, 2.0 TFSI, 2.0 TFSI 4x4		<b>F8-6569</b>		
Top Strut Mounting	1.2 TSI, 1.4 16V, 1.4 TSI, 1.6, 1.6 LPG, 1.6 Multifuel, 1.6 TDI, 1.8 TFSI, 1.9 TDI, 2.0 FSI, 2.0 TDI, 2.0 TDI 16V, 2.0 TDI 16V 4x4, 2.0 TDI 4x4, 2.0 TFSI, 2.0 TFSI 4x4		<b>F8-6570</b>		
Belt Pulley, crankshaft	1.6 TDI	Number of Ribs: 5; Parameter: 6PK	<b>F8-6572</b>		
Belt Pulley, crankshaft	2.0 TDI 16V	CFHC; Number of Ribs: 5; Parameter: 6PK	<b>F8-6572</b>		
Belt Pulley, crankshaft	2.0 TDI 4x4	CFJA; Number of Ribs: 5; Parameter: 6PK	<b>F8-6572</b>		
Engine Mounting	1.8 TFSI, 2.0 FSI, 2.0 TFSI 4x4		<b>F8-6989</b>		
Rubber Buffer, suspension	1.2 TSI, 1.6 TDI, 2.0 TDI 16V 4x4	for OE: G02, G07, G39, G40, G52, G53, G54, G55	<b>F8-7131</b>		H=70
Rubber Buffer, suspension	1.4 16V, 1.4 TSI, 1.6, 1.6 LPG, 1.6 Multifuel, 1.6 TDI, 1.8 TFSI, 1.9 TDI, 2.0 FSI, 2.0 TDI, 2.0 TDI 16V, 2.0 TDI 4x4, 2.0 TFSI, 2.0 TFSI 4x4	for OE: G02, G07, G52, G53, G54, G55	<b>F8-7131</b>		H=70
Protective Cap/Bellow, shock absorber	1.2 TSI, 1.4 16V, 1.4 TSI, 1.6, 1.6 LPG, 1.6 Multifuel, 1.6 TDI, 1.8 TFSI, 1.9 TDI, 2.0 FSI, 2.0 TDI, 2.0 TDI 16V, 2.0 TDI 4x4, 2.0 TFSI, 2.0 TFSI 4x4		<b>F8-7132</b>		H=190
Rubber Buffer, suspension	1.2 TSI, 1.4 16V, 1.4 TSI, 1.6, 1.6 LPG, 1.6 Multifuel, 1.6 TDI, 1.8 TFSI, 1.9 TDI, 2.0 FSI, 2.0 TDI, 2.0 TDI 16V, 2.0 TDI 16V 4x4, 2.0 TDI 4x4, 2.0 TFSI, 2.0 TFSI 4x4	for OE: UC0; Shape Oval; <b>ST</b>	<b>F8-7579</b>		H=100
Rubber Buffer, suspension	1.2 TSI, 1.4 16V, 1.4 TSI, 1.6, 1.6 LPG, 1.6 Multifuel, 1.6 TDI, 1.8 TFSI, 1.9 TDI, 2.0 FSI, 2.0 TDI, 2.0 TDI 16V, 2.0 TDI 16V 4x4, 2.0 TDI 4x4, 2.0 TFSI, 2.0 TFSI 4x4	for OE: 1JA, 1JC, 1JU, 1JV; <b>SP</b> , <b>ST</b>	<b>F8-7580</b>		H=101
Top Strut Mounting	1.2 TSI, 1.6 LPG, 1.6 TDI, 1.9 TDI, 2.0 TDI 16V 4x4	for OE: UC0; <b>ST</b>	<b>F8-7603</b>		
Top Strut Mounting	1.4 16V, 1.4 TSI, 1.6, 1.6 Multifuel, 1.8 TFSI, 1.9 TDI, 2.0 TDI, 2.0 TDI 16V, 2.0 TDI 4x4, 2.0 TFSI 4x4	07/2009 →; for OE: UC0; <b>ST</b>	<b>F8-7603</b>		
Protective Cap/Bellow, shock absorber	1.2 TSI, 1.4 16V, 1.4 TSI, 1.6, 1.6 LPG, 1.6 Multifuel, 1.6 TDI, 1.8 TFSI, 1.9 TDI, 2.0 FSI, 2.0 TDI, 2.0 TDI 16V	for OE: 1JA, 1JC, 1JV, UC0, UC2, UC3, UC4; <b>SP</b> , <b>ST</b>	<b>F8-7640</b>		H=176

<b>F8-6424</b>	<b>F8-6425</b>	<b>F8-6463</b>	<b>F8-6528</b>	<b>F8-6531</b>	<b>F8-6569</b>	<b>F8-6570</b>
Ref.Nr.: 1K0199232G	Ref.Nr.: 1K0199231J	Ref.Nr.: 1K0505541B	Ref.Nr.: 1K0 199 262 AT	Ref.Nr.: 1K0199262T	Ref.Nr.: 6N0412249C	Ref.Nr.: 1K0412331C
<b>F8-6572</b>	<b>F8-6989</b>	<b>F8-7131</b>	<b>F8-7132</b>	<b>F8-7579</b>	<b>F8-7580</b>	<b>F8-7603</b>
Ref.Nr.: 038105243L	Ref.Nr.: 1K0199262AM	Ref.Nr.: 1K0412303B	Ref.Nr.: 6N0413175A	Ref.Nr.: 1K0 511 353 J	Ref.Nr.: 1K0 511 353 Q	Ref.Nr.: 3C0513353
<b>F8-7640</b>	<b>F8-7834</b>					
Ref.Nr.: 1K0513425A	Ref.Nr.: 1K0412303H					

**Article Description****Article Nr.****Fitting Position****ALTEA XL (5P5, 5P8)****10/2006 → 05/2009**

Rubber Buffer, suspension	1.2 TSI, 1.4 16V, 1.4 TSI, 1.6, 1.6 LPG, 1.6 Multifuel, 1.6 TDI, 1.8 TFSI, 1.9 TDI, 2.0 TDI, 2.0 TDI 16V, 2.0 TDI 16V 4x4, 2.0 TDI 4x4, 2.0 TFSI 4x4	for OE: G50, G69	<b>F8-7834</b>		H=90
Rubber Buffer, suspension	1.2 TSI, 1.4 16V, 1.4 TSI, 1.6, 1.6 LPG, 1.6 Multifuel, 1.6 TDI, 1.8 TFSI, 1.9 TDI, 2.0 FSI, 2.0 TDI, 2.0 TDI 16V, 2.0 TDI 16V 4x4, 2.0 TDI 4x4, 2.0 TFSI, 2.0 TFSI 4x4	for OE: UC0; Shape Round;	<b>F8-7835</b>		H=75
Belt Pulley, crankshaft	1.8 TFSI, 2.0 TFSI 4x4	Number of Ribs: 5; Parameter: 6PK	<b>F8-7880</b>		D=143
Control Arm-/Trailing Arm Bush	1.2 TSI, 1.4 16V, 1.4 TSI, 1.6, 1.6 LPG, 1.6 Multifuel, 1.6 TDI, 1.8 TFSI, 1.9 TDI, 2.0 FSI, 2.0 TDI, 2.0 TDI 16V, 2.0 TDI 4x4, 2.0 TFSI 4x4		<b>F8-7902</b>		H=60; d=12; D=42
Control Arm-/Trailing Arm Bush	1.2 TSI, 1.4 16V, 1.4 TSI, 1.6, 1.6 LPG, 1.6 Multifuel, 1.6 TDI, 1.8 TFSI, 1.9 TDI, 2.0 FSI, 2.0 TDI, 2.0 TDI 16V, 2.0 TDI 4x4, 2.0 TFSI 4x4		<b>F8-7907</b>		H=45; d=14; D=38
Control Arm-/Trailing Arm Bush	1.2 TSI, 1.4 16V, 1.4 TSI, 1.6, 1.6 LPG, 1.6 Multifuel, 1.6 TDI, 1.8 TFSI, 1.9 TDI, 2.0 FSI, 2.0 TDI, 2.0 TDI 16V, 2.0 TDI 4x4, 2.0 TFSI 4x4		<b>F8-7908</b>		H=45; d=12; D=38
Control Arm-/Trailing Arm Bush	1.2 TSI, 1.4 16V, 1.4 TSI, 1.6, 1.6 LPG, 1.6 Multifuel, 1.6 TDI, 1.8 TFSI, 1.9 TDI, 2.0 FSI, 2.0 TDI, 2.0 TDI 16V, 2.0 TDI 4x4, 2.0 TFSI 4x4		<b>F8-7909</b>		
Engine Mounting	1.4 TSI		<b>F8-7959</b>		
Engine Mounting	1.4 16V, 1.4 TSI, 1.6, 1.6 LPG, 1.6 Multifuel		<b>F8-7960</b>		
Engine Mounting	1.6	6-speed	<b>F8-7961</b>		
Engine Mounting	1.6	BSF;  7-speed	<b>F8-7961</b>		
Engine Mounting	1.9 TDI	6-speed	<b>F8-7961</b>		
Engine Mounting	1.9 TDI, 2.0 TDI, 2.0 TDI 16V, 2.0 TDI 4x4	Transmission Type: DSG	<b>F8-7962</b>		
Engine Mounting	2.0 TFSI 4x4	6-speed	<b>F8-7962</b>		
Engine Mounting	1.6, 1.6 Multifuel	6-speed	<b>F8-7966</b>		
Engine Mounting	1.8 TFSI, 2.0 FSI		<b>F8-7966</b>		
Engine Mounting	1.4 16V, 1.4 TSI, 2.0 TFSI 4x4		<b>F8-7981</b>		
Engine Mounting	1.6	BGU, BSE, BSF	<b>F8-7981</b>		
Engine Mounting	1.6	BSF;	<b>F8-7981</b>		
Engine Mounting	1.8 TFSI	BYT, BZB	<b>F8-7981</b>		
Engine Mounting	1.9 TDI, 2.0 TDI, 2.0 TDI 4x4	ch.→5P-8-032600	<b>F8-7981</b>		
Engine Mounting	2.0 FSI		<b>F8-7981</b>		
Engine Mounting	2.0 FSI		<b>F8-7981</b>		
Engine Mounting	2.0 TDI 16V	ch.→5P-8-032600;  BKD	<b>F8-7981</b>		
Engine Mounting	2.0 TDI 16V	BKD	<b>F8-7981</b>		
Engine Mounting	2.0 TDI 4x4	ch.→5P-8-032600;  BMN	<b>F8-7981</b>		

<b>F8-7834</b>	<b>F8-7835</b>	<b>F8-7880</b>	<b>F8-7902</b>	<b>F8-7907</b>	<b>F8-7908</b>	<b>F8-7909</b>
Ref.Nr.: 1K0412303H	Ref.Nr.: 1K0511353S	Ref.Nr.: 06H105243F	Ref.Nr.: 1K0505171C	Ref.Nr.: 1K0505203A	Ref.Nr.: 1K0505279A	Ref.Nr.: 1K0505553 A
<b>F8-7959</b>	<b>F8-7960</b>	<b>F8-7961</b>	<b>F8-7962</b>	<b>F8-7966</b>	<b>F8-7981</b>	<b>F8-7982</b>
Ref.Nr.: 1K0199262CG	Ref.Nr.: 1K0199555L	Ref.Nr.: 1K0199555N	Ref.Nr.: 1K0199555Q	Ref.Nr.: 1K0199855BB	Ref.Nr.: 1K0199867Q	Ref.Nr.: 1K0199868Q

Article Description

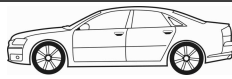

Article Nr.

Fitting Position



### ALTEA XL (5P5, 5P8)

10/2006 → 05/2009

Engine Mounting	1.2 TSI, 1.4 TSI, 1.6, 1.6 LPG, 1.6 Multifuel, 1.6 TDI, 1.8 TFSI, 1.9 TDI, 2.0 FSI, 2.0 TDI 16V 4x4, 2.0 TDI 4x4, 2.0 TFSI, 2.0 TFSI 4x4		F8-7982	↑	
Engine Mounting	1.4 16V	BXW, CGGB	F8-7982	↑	
Engine Mounting	1.9 TDI	BLS, BXE	F8-7982	↑	
Engine Mounting	2.0 TDI 16V	CFHC	F8-7982	↑	
Engine Mounting	2.0 TDI 4x4	BMN, CFJA	F8-7982	↑	
Engine Mounting	2.0 TDI, 2.0 TDI 16V, 2.0 TDI 4x4		F8-8152	⊕	

### AROSA (6H)

05/1997 → 06/2004

Dust Cover Kit, shock absorber	1.0, 1.4, 1.4 16V, 1.4 TDI, 1.7 SDI		AK-735031	⊕ ⊕ ⊕	
Dust Cover Kit, shock absorber	1.0, 1.4, 1.4 16V, 1.4 TDI, 1.7 SDI		AK-735409	⊕ ⊕ ⊕	
Dust Cover Kit, shock absorber	All Models		AK-735410	⊕ ⊕ ⊕	H=210
Alternator Freewheel Clutch	1.4 TDI		F5-1004		
Alternator Freewheel Clutch	1.7 SDI		F5-1010		
Alternator Freewheel Clutch	1.7 SDI		F5-1011		
Anti-Friction Bearing	All Models		F8-3039	⊕ ⊕ ⊕	H=14; d1=14; D=45
Bellow, steering	1.0, 1.4, 1.7 SDI		F8-5061	⊕ ⊕ ⊕	
Control Arm-/Trailing Arm Bush	1.0, 1.4, 1.7 SDI		F8-5104	⊕ ⊕ ⊕ ↓	H=47; d=10; D=28
Control Arm-/Trailing Arm Bush	1.0, 1.4, 1.7 SDI		F8-5105	⊕ ⊕ ⊕ ↓	H=46; d=17; D=61
Mounting, axle beam	1.0, 1.4, 1.4 16V, 1.4 TDI, 1.7 SDI		F8-5341		H=58; d=10; D=58
Repair Set, axle beam	1.0, 1.4, 1.4 16V, 1.4 TDI, 1.7 SDI		F8-5341S		d=10; D=58
Top Strut Mounting	All Models		F8-5494	⊕ ⊕ ⊕	d=26; D=83
Top Strut Mounting	1.0, 1.4, 1.4 16V, 1.4 TDI, 1.7 SDI		F8-5523	⊕ ⊕ ⊕	
Engine Mounting	1.0, 1.4, 1.4 16V		F8-5540	⊕	
Spring Cap	1.0, 1.4, 1.4 16V, 1.4 TDI, 1.7 SDI		F8-5580	⊕ ⊕ ⊕ ↑	D=92
Protective Cap/Bellow, shock absorber	All Models		F8-5683	⊕ ⊕ ⊕	H=210
Rubber Buffer, suspension	All Models		F8-5996	⊕ ⊕ ⊕	H=63
Rubber Buffer, suspension	1.0, 1.4, 1.4 16V, 1.4 TDI, 1.7 SDI		F8-6002	⊕ ⊕ ⊕	H=120
Protective Cap/Bellow, shock absorber	All Models		F8-6044	⊕ ⊕ ⊕	H=160
Stabiliser Mounting	1.0, 1.4, 1.4 16V, 1.4 TDI, 1.7 SDI	Stabi. Diam. [mm]= 18	F8-6190	⊕ ⊕ ⊕	d=16
Stabiliser Mounting	1.0, 1.4, 1.4 16V, 1.4 TDI, 1.7 SDI	for OE: 0AD / 0AH; Stabi. Diam. [mm]= 20, 22	F8-6191	⊕ ⊕ ⊕	d=18
Belt Pulley, crankshaft	1.7 SDI	Number of Ribs: 5	F8-6398		

<b>AK-735031</b>	<b>AK-735409</b>	<b>AK-735410</b>	<b>F5-1004</b>	<b>F5-1010</b>	<b>F5-1011</b>	<b>F8-3039</b>
Ref.Nr.:	Ref.Nr.: 1J0513425	Ref.Nr.: 1J0412303	Ref.Nr.: 038903119T	Ref.Nr.: 028903119S	Ref.Nr.: 038903119Q	Ref.Nr.: 357412249A
<b>F8-5061</b>	<b>F8-5104</b>	<b>F8-5105</b>	<b>F8-5341</b>	<b>F8-5341S</b>	<b>F8-5494</b>	<b>F8-5523</b>
Ref.Nr.: 6N0419831	Ref.Nr.: 6N0407182	Ref.Nr.: 6N0407181	Ref.Nr.: 6N0510541D	Ref.Nr.: 6N0501541D	Ref.Nr.: 6N0412331	Ref.Nr.: 6N0412331A
<b>F8-5540</b>	<b>F8-5580</b>	<b>F8-5683</b>	<b>F8-5996</b>	<b>F8-6002</b>	<b>F8-6044</b>	<b>F8-6190</b>
Ref.Nr.: 6N0199262L	Ref.Nr.: 1J0412341	Ref.Nr.: 357413175A	Ref.Nr.: 1H0412303B	Ref.Nr.: 6X0512131A	Ref.Nr.: 3C0513425	Ref.Nr.: 6X0411313



**Article Description****Article Nr.****Fitting Position**

<b>AROSA (6H)</b>			<b>05/1997 → 06/2004</b>	
Engine Mounting	1.0	ch.→6H-Y-020000;  AER, ALD, ANV;	<b>F8-6501</b>	
Engine Mounting	1.4	AEX, AKK, ANW, APQ, AUD;	<b>F8-6501</b>	
Engine Mounting	1.0	AER, ALD, ALL, ANV, AUC;	<b>F8-6923</b>	⊕
Engine Mounting	1.4		<b>F8-6923</b>	⊕
Engine Mounting	1.4 16V	AFK, AQQ, AUB;	<b>F8-6923</b>	⊕
Bellow, driveshaft	1.0, 1.4, 1.4 16V, 1.7 SDI		<b>F8-7722</b>	⊕ ⊕ ⊕ d1=26; d2=78; L=110
Engine Mounting	1.0, 1.4 16V		<b>F8-7948</b>	⊕
Belt Pulley, crankshaft	1.4 TDI	Number of Ribs: 5; Parameter: 6PK	<b>F8-8038</b>	
Engine Mounting	1.7 SDI		<b>F8-8189</b>	⊕
Bellow, steering	All Models	with clamps	<b>LM-10063S</b>	d1=11; d2=42; L [mm]=208
Bellow, steering	All Models	with clamps;	<b>LM-10088S</b>	d1=25; d2=40; L [mm]=143
<b>CORDOBA (6K1, 6K2)</b>			<b>02/1993 → 10/1999</b>	
Dust Cover Kit, shock absorber	1.0 i, 1.4 i, 1.4 i 16V, 1.6 i, 1.8 i, 1.8 i 16V, 1.9 D, 1.9 SDI, 1.9 TD, 1.9 TDI, 2.0 i		<b>AK-733023</b>	⊕ ⊕
Dust Cover Kit, shock absorber	All Models		<b>AK-735029</b>	⊕ ⊕
Dust Cover Kit, shock absorber	All Models		<b>AK-735032</b>	⊕ ⊕
Alternator Freewheel Clutch	1.9 TDI		<b>F5-1004</b>	
Alternator Freewheel Clutch	1.9 SDI, 1.9 TDI		<b>F5-1007</b>	
Control Arm-/Trailing Arm Bush	1.0 i, 1.4 i, 1.4 i 16V, 1.6 i, 1.8 i, 1.8 i 16V, 1.9 D, 1.9 SDI, 1.9 TD, 1.9 TDI, 2.0 i, 2.0 i 16V	without guide sleeve	<b>F8-1007</b>	⊕ ⊕ ⊕ ↓ H1=26; H2=41; d=17; D1=60; D2=68
Control Arm-/Trailing Arm Bush	1.0 i, 1.4 i, 1.4 i 16V, 1.6 i, 1.8 i, 1.8 i 16V, 1.9 D, 1.9 SDI, 1.9 TD, 1.9 TDI, 2.0 i, 2.0 i 16V	with guide sleeve	<b>F8-1007S</b>	⊕ ⊕ ⊕ ↓ H1=26; H2=41; d=17; D1=60; D2=68
Repair Kit, link	1.0 i, 1.4 i, 1.4 i 16V, 1.6 i, 1.7 SDI, 1.8 i, 1.8 i 16V, 1.9 D, 1.9 SDI, 1.9 TD, 1.9 TDI, 2.0 i, 2.0 i 16V	with guide sleeve	<b>F8-1008</b>	⊕ ⊕ ⊕ ↓ H1=24; H2=41; d=17; D=60
Top Strut Mounting	1.4 i, 1.6 i, 1.8 i, 1.9 D, 1.9 TD	ch.→6K-TR080000	<b>F8-1009B</b>	⊕ ⊕ ⊕ d=14; D=132
Top Strut Mounting	1.6 i, 1.9 D, 1.9 SDI, 1.9 TDI		<b>F8-1009B</b>	⊕ ⊕ ⊕ d=14; D=132
Top Strut Mounting	1.8 i 16V, 2.0 i	ch.→6K-ZR082400, 6K-ZR599964	<b>F8-1009B</b>	⊕ ⊕ ⊕ d=14; D=132
Engine Mounting	1.4 i 16V, 1.6 i, 1.8 i, 1.9 TDI, 2.0 i 16V		<b>F8-1011</b>	⊕ H=133; D1=80; D2=108
Engine Mounting	1.4 i 16V, 1.6 i, 1.8 i, 1.8 i 16V, 1.9 D, 1.9 TD, 2.0 i		<b>F8-1015</b>	⊕ H=82; D1=55; D2=71
Top Strut Mounting	1.0 CL, 1.4, 1.4 i, 1.6 i, 1.9 D, 1.9 SDI, 1.9 TDI, 2.0 i 16V		<b>F8-1034</b>	⊕ ⊕ H=50; d=27; D=98
Top Strut Mounting	1.0 i, 1.4 i 16V, 1.6 i, 1.9 TDI, 2.0 i	01/1997 →;	<b>F8-1034</b>	⊕ ⊕ H=50; d=27; D=98
Top Strut Mounting	1.8 i 16V	01/1994 →;	<b>F8-1034</b>	⊕ ⊕ H=50; d=27; D=98
Top Strut Mounting	1.8 i, 1.9 TD	01/1996 →;	<b>F8-1034</b>	⊕ ⊕ H=50; d=27; D=98
Top Strut Mounting	1.0 CL, 1.4, 1.4 i, 1.6 i, 1.9 D, 1.9 SDI, 1.9 TDI, 2.0 i 16V		<b>F8-1034S</b>	⊕ ⊕ H=51; d=14; D=96
Top Strut Mounting	1.0 i, 1.4 i 16V, 1.6 i, 1.9 TDI, 2.0 i	01/1997 →;	<b>F8-1034S</b>	⊕ ⊕ H=51; d=14; D=96

<b>AK-733023</b>	<b>AK-735029</b>	<b>AK-735032</b>	<b>F5-1004</b>	<b>F5-1007</b>	<b>F8-1007</b>	<b>F8-1007S</b>
Ref.Nr.: 191412303	Ref.Nr.:	Ref.Nr.:	Ref.Nr.: 038903119T	Ref.Nr.: 028903119AQ	Ref.Nr.: 191407181A	Ref.Nr.: 191407181A
<b>F8-1008</b>	<b>F8-1009B</b>	<b>F8-1011</b>	<b>F8-1015</b>	<b>F8-1034</b>	<b>F8-1034S</b>	<b>F8-6501</b>
Ref.Nr.: 191407181E	Ref.Nr.: 176412329	Ref.Nr.: 1H0199262F	Ref.Nr.: 357199402	Ref.Nr.: 357412331A	Ref.Nr.: 7201848S1	Ref.Nr.: 6N0 199 851 AG
<b>F8-6923</b>	<b>F8-7722</b>	<b>F8-7948</b>	<b>F8-8038</b>	<b>F8-8189</b>	<b>LM-10063S</b>	<b>LM-10088S</b>
Ref.Nr.: 6N0199555AA	Ref.Nr.: 191407285F	Ref.Nr.: 6N0199262G	Ref.Nr.: 045105243C	Ref.Nr.: 6N0199555H	Ref.Nr.: 6N0422831	Ref.Nr.: 6N0419831

Article Description



Article Nr.

Fitting Position



CORDOBA (6K1, 6K2)			02/1993 → 10/1999		
Top Strut Mounting	1.8 i 16V	01/1994 →; ☼	F8-1034S		H=51; d=14; D=96
Top Strut Mounting	1.8 i, 1.9 TD	01/1996 →; ☼	F8-1034S		H=51; d=14; D=96
Anti-Friction Bearing	1.0 i	ch.→6K-X-290000	F8-3039		H=14; d1=14; D=45
Anti-Friction Bearing	1.4 i, 1.4 i 16V, 1.6 i, 1.8 i, 1.8 i 16V, 1.9 D, 1.9 TD, 2.0 i, 2.0 i 16V		F8-3039		H=14; d1=14; D=45
Anti-Friction Bearing	1.9 SDI, 1.9 TDI	ch.→6K-X-399999	F8-3039		H=14; d1=14; D=45
Stabiliser Mounting	1.0 i, 1.4 i 16V, 1.6 i, 1.8 i, 1.9 D, 1.9 SDI, 1.9 TD, 1.9 TDI, 2.0 i, 2.0 i 16V	ch.→6K-V-143400	F8-3042		H=33; d=17; W=35
Stabiliser Mounting	1.4 i, 1.6 i, 1.8 i 16V		F8-3042		H=33; d=17; W=35
Flange, carburettor	1.6 i, 1.8 i		F8-3048		H=27; d=40
Engine Mounting	1.9 D, 1.9 TD		F8-3053		H=135; D1=79; D2=93
Engine Mounting	1.9 D		F8-4016		
Engine Mounting	1.9 TD	10/1993 →	F8-4016		
Engine Mounting	1.0 i, 1.4 i		F8-4017		
Rubber Buffer, suspension	1.4 i, 1.6 i, 1.8 i, 1.8 i 16V, 1.9 D, 1.9 TD, 2.0 i		F8-4063		H=83; d1=18; d2=25; D1=48; D2=60
Protective Cap/Bellow, shock absorber	1.4 i, 1.6 i, 1.8 i, 1.9 D, 1.9 TD	ch.→6K-TR080000	F8-4064		H=90; d1=50; d2=71; D1=66; D2=77
Protective Cap/Bellow, shock absorber	1.8 i 16V, 2.0 i	ch.→6K-ZR082400, 6K-ZR599964	F8-4064		H=90; d1=50; d2=71; D1=66; D2=77
Bellow, steering	1.0 i, 1.4 i, 1.4 i 16V, 1.6 i, 1.8 i, 1.8 i 16V, 1.9 D, 1.9 SDI, 1.9 TD, 1.9 TDI, 2.0 i, 2.0 i 16V		F8-4069		
Bellow, steering	1.4 i, 1.6 i, 1.8 i, 1.8 i 16V, 1.9 D, 1.9 TD, 2.0 i		F8-4075		H=200; d=10; D=48
Mounting, steering gear	1.0 i, 1.4 i, 1.4 i 16V, 1.6 i, 1.8 i, 1.8 i 16V, 1.9 D, 1.9 SDI, 1.9 TD, 1.9 TDI, 2.0 i, 2.0 i 16V		F8-5145		d1=50.7; d2=48.3
Mounting, axle beam	1.0 i, 1.4 i, 1.4 i 16V, 1.6 i, 1.8 i, 1.8 i 16V, 1.9 D, 1.9 SDI, 1.9 TD, 1.9 TDI, 2.0 i, 2.0 i 16V	ch.6K-ZR037978, 6K-ZR549077→	F8-5341		H=58; d=10; D=58
Repair Set, axle beam	1.0 i, 1.4 i, 1.4 i 16V, 1.6 i, 1.8 i, 1.8 i 16V, 1.9 D, 1.9 SDI, 1.9 TD, 1.9 TDI, 2.0 i, 2.0 i 16V	ch.6K-ZR037978, 6K-ZR549077→	F8-5341S		d=10; D=58
Engine Mounting	1.6 i, 1.9 SDI	Brown	F8-5346		
Engine Mounting	2.0 i	Brown;  AGG	F8-5346		
Stabiliser Mounting	1.4 i 16V, 1.9 TDI		F8-5395		d=19
Stabiliser Mounting	1.6 i, 1.9 D, 1.9 SDI, 1.9 TD, 1.9 TDI, 2.0 i 16V	ch.6K-V-143401→	F8-5395		d=19
Stabiliser Mounting	1.8 i	ch.6K-V-143401→;  ADZ	F8-5395		d=19
Stabiliser Mounting	2.0 i	ch.6K-V-143401→;  AGG	F8-5395		d=19
Engine Mounting	1.8 i 16V, 1.9 TDI, 2.0 i 16V		F8-5396		
Engine Mounting	2.0 i	2E	F8-5396		
Engine Mounting	1.4 i 16V, 1.6 i, 1.8 i		F8-5397		
Engine Mounting	1.6 i	AEE, ALM	F8-5397		

<b>F8-1034S</b>	<b>F8-3039</b>	<b>F8-3042</b>	<b>F8-3048</b>	<b>F8-3053</b>	<b>F8-4016</b>	<b>F8-4017</b>
Ref.Nr.: 7201848S1	Ref.Nr.: 357412249A	Ref.Nr.: 191411314	Ref.Nr.: 050129761B	Ref.Nr.: 1H0199609B	Ref.Nr.: 1H0199262G	Ref.Nr.: 1H0199262E
<b>F8-4063</b>	<b>F8-4064</b>	<b>F8-4069</b>	<b>F8-4075</b>	<b>F8-5145</b>	<b>F8-5341</b>	<b>F8-5341S</b>
Ref.Nr.: 191412303A	Ref.Nr.: 191412135	Ref.Nr.: 171419831B	Ref.Nr.: 357422831	Ref.Nr.: 191419883	Ref.Nr.: 6N0501541D	Ref.Nr.: 6N0501541D
<b>F8-5346</b>	<b>F8-5395</b>	<b>F8-5396</b>	<b>F8-5397</b>	<b>F8-5398</b>		
Ref.Nr.: 1H0199609G	Ref.Nr.: 1H0411314	Ref.Nr.: 1H0199609J	Ref.Nr.: 1H0199609F	Ref.Nr.: 1H0199609E		

**Article Description****Article Nr.****Fitting Position**

<b>CORDOBA (6K1, 6K2)</b>			<b>02/1993 → 10/1999</b>	
Engine Mounting	1.0 i, 1.4 i		<b>F8-5398</b>	
Engine Mounting	1.6 i	ABU	<b>F8-5398</b>	
Top Strut Mounting	1.0 i, 1.4 i 16V, 1.6 i, 1.8 i, 1.9 SDI, 1.9 TDI, 2.0 i, 2.0 i 16V	ch.→6K-X-399999	<b>F8-5402</b>	   
Top Strut Mounting	1.4 i	ch.→6K-X-399999;  ABD, AEX, AKV, APQ	<b>F8-5402</b>	   
Top Strut Mounting	1.8 i 16V, 1.9 D, 1.9 TD		<b>F8-5402</b>	   
Top Strut Mounting	1.0 i, 1.4 i 16V, 1.6 i, 1.8 i, 1.9 SDI, 1.9 TDI, 2.0 i, 2.0 i 16V	ch.→6K-X-399999	<b>F8-5403</b>	   
Top Strut Mounting	1.4 i	ch.→6K-X-399999;  ABD, AEX, AKV, APQ	<b>F8-5403</b>	   
Top Strut Mounting	1.8 i 16V, 1.9 D, 1.9 TD		<b>F8-5403</b>	   
Engine Mounting	1.9 TDI	ch.→6K-X-399999	<b>F8-5491</b>	 
Top Strut Mounting	1.4	ch.6K-X-400000→;  ANX;	<b>F8-5537</b>	  
Top Strut Mounting	1.4 i	ch.6K-X-400000→;  APQ;	<b>F8-5537</b>	  
Top Strut Mounting	1.6 i	ch.6K-X-400000→;  ABU;	<b>F8-5537</b>	  
Top Strut Mounting	1.8 i	ch.6K-X-400000→;  ADZ;	<b>F8-5537</b>	  
Top Strut Mounting	1.8 i 16V	ch.6K-X-400000→;	<b>F8-5537</b>	  
Top Strut Mounting	1.9 TDI	ch.6K-X-400000→;  AHU;	<b>F8-5537</b>	  
Engine Mounting	1.4 i, 1.4 i 16V, 1.6 i, 1.8 i, 1.9 D, 1.9 TD		<b>F8-5554</b>	  
Belt Pulley, crankshaft	1.9 D, 1.9 SDI, 1.9 TD, 1.9 TDI	Number of Ribs: 5; Parameter: 6PK	<b>F8-5649</b>	
Holder, engine mounting	1.6 i, 1.9 SDI, 1.9 TDI		<b>F8-5672</b>	  
Rubber Buffer, suspension	1.4 i, 1.6 i, 1.8 i, 1.9 D, 1.9 TD	02/1996 →	<b>F8-5993</b>	  
Rubber Buffer, suspension	1.8 i 16V, 2.0 i	06/1994 →	<b>F8-5993</b>	  
Rubber Buffer, suspension	1.9 SDI, 2.0 i 16V		<b>F8-5993</b>	  
Top Strut Mounting	1.4 i, 1.6 i		<b>F8-6281</b>	
Repair Kit, suspension strut	1.0 i, 1.4 i, 1.4 i 16V, 1.6 i, 1.8 i, 1.8 i 16V, 1.9 D, 1.9 SDI, 1.9 TD, 1.9 TDI, 2.0 i, 2.0 i 16V		<b>F8-6382</b>	
Anti-Friction Bearing	1.9 SDI, 1.9 TDI	ch.6K-X-400000→	<b>F8-6569</b>	
Sleeve, control arm mounting	1.0 i, 1.4 i, 1.4 i 16V, 1.6 i, 1.7 SDI, 1.8 i, 1.8 i 16V, 1.9 D, 1.9 SDI, 1.9 TD, 1.9 TDI, 2.0 i, 2.0 i 16V		<b>F8-6699</b>	  
Engine Mounting	1.0 i, 1.4 i, 1.9 SDI	ch.→6K-X-399999	<b>F8-6922</b>	
Protective Cap/Bellow, shock absorber	1.0 i, 1.4, 1.4 i, 1.4 i 16V, 1.6 i, 1.8 i, 1.9 D, 1.9 SDI, 1.9 TDI, 2.0 i, 2.0 i 16V		<b>F8-7132</b>	  
Bellow, driveshaft	1.0 i, 1.4 i 16V, 1.9 D, 1.9 SDI		<b>F8-7722</b>	  
Bellow, driveshaft	1.4 i	ABD, AEX	<b>F8-7722</b>	  
Bellow, driveshaft	1.6 i	ABU, AEE	<b>F8-7722</b>	  

<b>F8-5398</b>	<b>F8-5402</b>	<b>F8-5403</b>	<b>F8-5491</b>	<b>F8-5537</b>	<b>F8-5554</b>	<b>F8-5649</b>
Ref.Nr.: 1H0199609E	Ref.Nr.: 191512335	Ref.Nr.: 191512333	Ref.Nr.: 357199381	Ref.Nr.: 6N0412331E	Ref.Nr.: 191199233	Ref.Nr.: 028105243T
<b>F8-5672</b>	<b>F8-5993</b>	<b>F8-6281</b>	<b>F8-6382</b>	<b>F8-6569</b>	<b>F8-6699</b>	<b>F8-6922</b>
Ref.Nr.: 1H0199233A	Ref.Nr.: 357412303F	Ref.Nr.: 8Z0412331	Ref.Nr.: 191512333S	Ref.Nr.: 6N0412249C	Ref.Nr.: 191407190A	Ref.Nr.: 191199381A
<b>F8-7132</b>	<b>F8-7722</b>					
Ref.Nr.: 6N0413175A	Ref.Nr.: 191407285F					

Article Description



Article Nr.

Fitting Position



<b>CORDOBA (6K1, 6K2)</b>			<b>02/1993 → 10/1999</b>		
Bellow, driveshaft	1.6 i	AFT	<b>F8-7722</b>		d1=26; d2=78; L=110
Control Arm-/Trailing Arm Bush	1.0 CL, 1.0 i, 1.3, 1.4, 1.4 i, 1.4 i 16V, 1.6 i, 1.8 i, 1.8 i 16V, 1.9 D, 1.9 SDI, 1.9 TD, 1.9 TDI, 2.0 i, 2.0 i 16V		<b>F8-7978</b>		
Control Arm-/Trailing Arm Bush	1.0 i, 1.4 i, 1.4 i 16V, 1.6 i, 1.7 SDI, 1.8 i, 1.8 i 16V, 1.9 D, 1.9 SDI, 1.9 TD, 1.9 TDI, 2.0 i, 2.0 i 16V		<b>G9-648</b>		H=54; d=12; D1=33; D2=36
Bellow, steering	All Models	with clamps;	<b>LM-10003S</b>		d1=9; d2=43; L [mm]=210
Bellow, steering	All Models	with clamps;	<b>LM-10006S</b>		d1=10; d2=41; L [mm]=210
Bellow, steering	1.0 CL, 1.0 i, 1.3, 1.4, 1.4 i 16V, 1.6 i, 1.7 SDI, 1.8 i, 1.8 i 16V, 1.9 D, 1.9 SDI, 1.9 TD, 1.9 TDI, 2.0 i, 2.0 i 16V	with clamps;	<b>LM-10024S</b>		d1=25; d2=41; L [mm]=120
Bellow, steering	1.4 i	with clamps;	<b>LM-10024S</b>		d1=25; d2=41; L [mm]=120
Bellow, steering	1.0 CL, 1.0 i, 1.3, 1.4, 1.4 i 16V, 1.6 i, 1.7 SDI, 1.8 i, 1.8 i 16V, 1.9 D, 1.9 SDI, 1.9 TD, 1.9 TDI, 2.0 i, 2.0 i 16V	with clamps;	<b>LM-10050S</b>		d1=25; d2=39; L [mm]=126
Bellow, steering	1.4 i	with clamps;	<b>LM-10050S</b>		d1=25; d2=39; L [mm]=126
Bellow, driveshaft	1.0 i, 1.4 i, 1.4 i 16V, 1.6 i, 1.9 D, 1.9 SDI		<b>M-830220</b>		
Bellow Set, drive shaft	1.0 i, 1.4 i, 1.4 i 16V, 1.6 i, 1.9 D, 1.9 SDI		<b>MK-830220</b>		
Bellow Set, drive shaft	1.6 i	ABU, AEE	<b>MK-830220</b>		
Bellow Set, drive shaft	1.0 i, 1.4 i 16V, 1.9 D, 1.9 SDI		<b>MK-830220S</b>		
<b>CORDOBA Vario (6K5)</b>			<b>08/1996 → 06/1999</b>		
Dust Cover Kit, shock absorber	1.4 i, 1.6 i, 1.7 SDI, 1.9 SDI, 1.9 TDI		<b>AK-733023</b>		
Dust Cover Kit, shock absorber	All Models		<b>AK-735029</b>		
Alternator Freewheel Clutch	1.9 SDI, 1.9 TDI		<b>F5-1004</b>		
Alternator Freewheel Clutch	1.9 SDI, 1.9 TDI		<b>F5-1007</b>		
Control Arm-/Trailing Arm Bush	1.4 i, 1.6 i, 1.9 SDI, 1.9 TDI	without guide sleeve	<b>F8-1007</b>		H1=26; H2=41; d=17; D1=60; D2=68
Control Arm-/Trailing Arm Bush	1.4 i, 1.6 i, 1.9 SDI, 1.9 TDI	with guide sleeve	<b>F8-1007S</b>		H1=26; H2=41; d=17; D1=60; D2=68
Repair Kit, link	All Models	with guide sleeve	<b>F8-1008</b>		H1=24; H2=41; d=17; D=60
Top Strut Mounting	1.4 i, 1.6 i, 1.7 SDI, 1.9 SDI, 1.9 TDI		<b>F8-1009B</b>		d=14; D=132
Engine Mounting	1.6 i, 1.9 TDI		<b>F8-1011</b>		H=133; D1=80; D2=108
Engine Mounting	1.6 i		<b>F8-1015</b>		H=82; D1=55; D2=71
Top Strut Mounting	1.4 i, 1.6 i, 1.9 SDI, 1.9 TDI		<b>F8-1034</b>		H=50; d=27; D=98
Top Strut Mounting	1.6 i, 1.9 TDI	01/1997 →;	<b>F8-1034</b>		H=50; d=27; D=98
Top Strut Mounting	1.4 i, 1.6 i, 1.9 SDI, 1.9 TDI		<b>F8-1034S</b>		H=51; d=14; D=96
Top Strut Mounting	1.6 i, 1.9 TDI	01/1997 →;	<b>F8-1034S</b>		H=51; d=14; D=96
Anti-Friction Bearing	All Models	ch.→6K-X-290000	<b>F8-3039</b>		H=14; d1=14; D=45



**Article Description****Article Nr.****Fitting Position**

<b>CORDOBA Vario (6K5)</b>			<b>08/1996 → 06/1999</b>		
Stabiliser Mounting	1.4 i, 1.6, 1.6 i		<b>F8-3042</b>		H=33; d=17; W=35
Stabiliser Mounting	1.6 i, 1.9 SDI, 1.9 TDI	ch.→6K-V-143400	<b>F8-3042</b>		H=33; d=17; W=35
Flange, carburettor	1.6 i		<b>F8-3048</b>		H=27; d=40
Engine Mounting	1.4 i		<b>F8-4017</b>		
Bellow, steering	1.4 i, 1.6 i, 1.9 SDI, 1.9 TDI		<b>F8-4069</b>		
Mounting, steering gear	1.4 i, 1.6 i, 1.9 SDI, 1.9 TDI		<b>F8-5145</b>		d1=50.7; d2=48.3
Mounting, axle beam	1.4 i, 1.6 i, 1.9 SDI, 1.9 TDI	ch.6K-ZR037978, 6K-ZR549077→	<b>F8-5341</b>		H=58; d=10; D=58
Repair Set, axle beam	1.4 i, 1.6 i, 1.9 SDI, 1.9 TDI	ch.6K-ZR037978, 6K-ZR549077→	<b>F8-5341S</b>		d=10; D=58
Engine Mounting	1.4 16V, 1.6 i, 1.9 SDI	Brown	<b>F8-5346</b>		
Stabiliser Mounting	1.4 16V, 1.9 TDI		<b>F8-5395</b>		d=19
Stabiliser Mounting	1.6 i, 1.9 SDI, 1.9 TDI	ch.6K-V-143401→	<b>F8-5395</b>		d=19
Engine Mounting	1.9 TDI		<b>F8-5396</b>		
Engine Mounting	1.6, 1.6 i		<b>F8-5397</b>		
Engine Mounting	1.4, 1.4 i		<b>F8-5398</b>		
Top Strut Mounting	1.4 i	ch.→6K-X-399999;  AEX, AKV, APQ	<b>F8-5402</b>		
Top Strut Mounting	1.6 i, 1.9 SDI, 1.9 TDI	ch.→6K-X-399999	<b>F8-5402</b>		
Top Strut Mounting	1.4 i	ch.→6K-X-399999;  AEX, AKV, APQ	<b>F8-5403</b>		
Top Strut Mounting	1.6 i, 1.9 SDI, 1.9 TDI	ch.→6K-X-399999	<b>F8-5403</b>		
Engine Mounting	1.9 TDI	ch.→6K-X-399999	<b>F8-5491</b>		
Engine Mounting	1.4 16V, 1.4 i, 1.6 i		<b>F8-5554</b>		H=39.5; d1=16; d2=24; D=50
Belt Pulley, crankshaft	1.9 SDI, 1.9 TDI	Number of Ribs: 5; Parameter: 6PK	<b>F8-5649</b>		H=31.5; d=30.02; Mounting points diam.[mm]=8.5; D1=161.5; D2=160.5
Holder, engine mounting	1.6, 1.6 i, 1.9 SDI, 1.9 TDI		<b>F8-5672</b>		H=39.5; D=24
Rubber Buffer, suspension	1.4 i, 1.6 i, 1.7 SDI, 1.9 SDI, 1.9 TDI		<b>F8-5993</b>		H=83
Top Strut Mounting	All Models	05/1999 →;	<b>F8-6281</b>		
Repair Kit, suspension strut	All Models		<b>F8-6382</b>		
Anti-Friction Bearing	1.4 i, 1.6 i, 1.7 SDI, 1.9 SDI, 1.9 TDI	ch.6K-X-290001→	<b>F8-6569</b>		
Sleeve, control arm mounting	All Models		<b>F8-6699</b>		d=16; L=50; D=17
Engine Mounting	1.9 SDI	ch.→6K-X-399999	<b>F8-6922</b>		H=65
Protective Cap/Bellow, shock absorber	All Models		<b>F8-7132</b>		H=190
Bellow, driveshaft	1.4 i	AEX	<b>F8-7722</b>		d1=26; d2=78; L=110
Bellow, driveshaft	1.6 i	AEE	<b>F8-7722</b>		d1=26; d2=78; L=110
Bellow, driveshaft	1.6, 1.6 i, 1.9 SDI		<b>F8-7722</b>		d1=26; d2=78; L=110
Mounting, axle beam	1.4, 1.4 16V, 1.4 i, 1.6, 1.6 i, 1.9 SDI, 1.9 TDI		<b>F8-7938</b>		H=80; D=72

<b>F8-3042</b>	<b>F8-3048</b>	<b>F8-4017</b>	<b>F8-4069</b>	<b>F8-5145</b>	<b>F8-5341</b>	<b>F8-5341S</b>
Ref.Nr.: 191411314	Ref.Nr.: 050129761B	Ref.Nr.: 1H0199262E	Ref.Nr.: 171419831B	Ref.Nr.: 191419883	Ref.Nr.: 6N0501541D	Ref.Nr.: 6N0501541D
<b>F8-5346</b>	<b>F8-5395</b>	<b>F8-5396</b>	<b>F8-5397</b>	<b>F8-5398</b>	<b>F8-5402</b>	<b>F8-5403</b>
Ref.Nr.: 1H0199609G	Ref.Nr.: 1H0411314	Ref.Nr.: 1H0199609J	Ref.Nr.: 1H0199609F	Ref.Nr.: 1H0199609E	Ref.Nr.: 191512335	Ref.Nr.: 191512333
<b>F8-5491</b>	<b>F8-5554</b>	<b>F8-5649</b>	<b>F8-5672</b>	<b>F8-5993</b>	<b>F8-6281</b>	<b>F8-6382</b>
Ref.Nr.: 357199381	Ref.Nr.: 191199233	Ref.Nr.: 028105243T	Ref.Nr.: 1H0199233A	Ref.Nr.: 357412303F	Ref.Nr.: 8Z0412331	Ref.Nr.: 191512333S

Article Description



Article Nr.

Fitting Position



<b>CORDOBA Vario (6K5)</b>			<b>08/1996 → 06/1999</b>	
Control Arm-/Trailing Arm Bush	1.4 i, 1.6 i, 1.9 SDI, 1.9 TDI		<b>F8-7978</b>	
Control Arm-/Trailing Arm Bush	1.4 i, 1.6 i, 1.7 SDI, 1.9 SDI, 1.9 TDI		<b>G9-648</b>	H1=54; d=12; D1=33; D2=36
Bellow, steering	All Models	with clamps;	<b>LM-10003S</b>	d1=9; d2=43; L [mm]=210
Bellow, steering	All Models	with clamps;	<b>LM-10006S</b>	d1=10; d2=41; L [mm]=210
Bellow, steering	All Models	with clamps;	<b>LM-10024S</b>	d1=25; d2=41; L [mm]=120
Bellow, steering	All Models	with clamps;	<b>LM-10050S</b>	d1=25; d2=39; L [mm]=126
Bellow, driveshaft	1.4 i, 1.6, 1.6 i, 1.9 SDI		<b>M-830220</b>	
Bellow Set, drive shaft	1.4 i	AEX	<b>MK-830220</b>	
Bellow Set, drive shaft	1.6 i	AEE	<b>MK-830220</b>	
Bellow Set, drive shaft	1.6, 1.6 i, 1.9 SDI		<b>MK-830220</b>	
Bellow Set, drive shaft	1.6, 1.6 i, 1.9 SDI		<b>MK-830220S</b>	
<b>CORDOBA (6K2)</b>			<b>06/1999 → 10/2002</b>	
Dust Cover Kit, shock absorber	All Models		<b>AK-735029</b>	
Dust Cover Kit, shock absorber	All Models		<b>AK-735032</b>	
Alternator Freewheel Clutch	1.9 SDI, 1.9 TDI		<b>F5-1004</b>	
Repair Kit, link	1.0, 1.4, 1.4 16V, 1.6, 1.8 T 20V Cupra, 1.9 SDI, 1.9 TDI	with guide sleeve	<b>F8-1008</b>	H1=24; H2=41; d=17; D=60
Engine Mounting	1.8 T 20V Cupra		<b>F8-4016</b>	
Engine Mounting	1.4 16V	Brown	<b>F8-5346</b>	
Stabiliser Mounting	1.4 16V	AUB	<b>F8-5395</b>	d=19
Stabiliser Mounting	1.4 16V, 1.8 T 20V Cupra		<b>F8-5395</b>	d=19
Stabiliser Mounting	1.6	ch.6K-X-430580→	<b>F8-5395</b>	d=19
Stabiliser Mounting	1.6	AEH	<b>F8-5395</b>	d=19
Stabiliser Mounting	1.9 SDI	ch.6K-X-400000→	<b>F8-5395</b>	d=19
Stabiliser Mounting	1.9 TDI	ch.6K-X-400000→;  ALH	<b>F8-5395</b>	d=19
Stabiliser Mounting	1.9 TDI	ch.6K-X-400000→;  ASV	<b>F8-5395</b>	d=19
Engine Mounting	1.6	AEH, AKL	<b>F8-5397</b>	
Engine Mounting	1.4		<b>F8-5398</b>	
Top Strut Mounting	1.0, 1.4, 1.4 16V, 1.6, 1.9 SDI, 1.9 TDI	ch.6K-X-400000→	<b>F8-5402</b>	
Top Strut Mounting	1.4 16V, 1.8 T 20V Cupra		<b>F8-5402</b>	
Top Strut Mounting	1.9 TDI	ch.6K-X-400000→;  ASV	<b>F8-5402</b>	
Top Strut Mounting	1.0, 1.4, 1.4 16V, 1.6, 1.9 SDI, 1.9 TDI	ch.6K-X-400000→	<b>F8-5403</b>	
Top Strut Mounting	1.4 16V, 1.8 T 20V Cupra		<b>F8-5403</b>	

<b>AK-735029</b>	<b>AK-735032</b>	<b>F5-1004</b>	<b>F8-1008</b>	<b>F8-4016</b>	<b>F8-5346</b>	<b>F8-5395</b>
Ref.Nr.:	Ref.Nr.:	Ref.Nr.: 038903119T	Ref.Nr.: 191407181E	Ref.Nr.: 1H0199262G	Ref.Nr.: 1H0199609G	Ref.Nr.: 1H0411314
<b>F8-5397</b>	<b>F8-5398</b>	<b>F8-5402</b>	<b>F8-5403</b>	<b>F8-7978</b>	<b>G9-648</b>	<b>LM-10003S</b>
Ref.Nr.: 1H0199609F	Ref.Nr.: 1H0199609E	Ref.Nr.: 191512335	Ref.Nr.: 191512333	Ref.Nr.: 357407182F	Ref.Nr.: 357407182	Ref.Nr.: 357422831A
<b>LM-10006S</b>	<b>LM-10024S</b>	<b>LM-10050S</b>	<b>M-830220</b>	<b>MK-830220</b>	<b>MK-830220S</b>	
Ref.Nr.: 1H0422831B	Ref.Nr.: 171419831B	Ref.Nr.: 171419831C	Ref.Nr.: 191498203C	Ref.Nr.: 171498203	Ref.Nr.:	

**Article Description****Article Nr.****Fitting Position****CORDOBA (6K2) 06/1999 → 10/2002**

Top Strut Mounting	1.9 TDI	ch.6K-X-400000→;  ASV	<b>F8-5403</b>		
Engine Mounting	1.9 TDI	ch.6K-X-400001→	<b>F8-5491</b>		
Engine Mounting	1.9 TDI	ch.6K-X-400001→;  ASV	<b>F8-5491</b>		
Top Strut Mounting	1.0, 1.4, 1.4 16V, 1.6, 1.8 T 20V Cupra, 1.9 SDI	ch.6K-X-400000→;  ASV	<b>F8-5537</b>		
Top Strut Mounting	1.4 16V	ch.6K-X-400000→;  AUB;  ASV	<b>F8-5537</b>		
Top Strut Mounting	1.6	ch.6K-X-400000→;  AKL;  ASV	<b>F8-5537</b>		
Top Strut Mounting	1.9 TDI	ch.6K-X-400000→;  ALH;  ASV	<b>F8-5537</b>		
Top Strut Mounting	1.9 TDI	ch.6K-X-400000→;  ASV;  ASV	<b>F8-5537</b>		
Engine Mounting	1.4, 1.4 16V		<b>F8-5554</b>		H=39.5; d1=16; d2=24; D=50
Belt Pulley, crankshaft	1.8 T 20V Cupra		<b>F8-5650</b>		
Holder, engine mounting	1.6, 1.8 T 20V Cupra, 1.9 SDI, 1.9 TDI		<b>F8-5672</b>		H=39.5; D=24
Top Strut Mounting	All Models	ASV	<b>F8-6281</b>		
Repair Kit, suspension strut	All Models		<b>F8-6382</b>		
Anti-Friction Bearing	All Models		<b>F8-6569</b>		
Sleeve, control arm mounting	All Models		<b>F8-6699</b>		d=16; L=50; D=17
Engine Mounting	1.0, 1.4, 1.9 SDI		<b>F8-6922</b>		H=65
Protective Cap/Bellow, shock absorber	All Models		<b>F8-7132</b>		H=190
Bellow, driveshaft	1.6		<b>F8-7722</b>		d1=26; d2=78; L=110
Mounting, axle beam	All Models		<b>F8-7938</b>		H=80; D=72
Control Arm-/Trailing Arm Bush	1.4, 1.4 16V, 1.6, 1.8 T 20V Cupra, 1.9 SDI, 1.9 TDI		<b>G9-648</b>		H=54; d=12; D1=33; D2=36
Bellow, steering	All Models	with clamps;  ASV	<b>LM-10003S</b>		d1=9; d2=43; L [mm]=210
Bellow, steering	All Models	with clamps;  ASV	<b>LM-10006S</b>		d1=10; d2=41; L [mm]=210
Bellow, steering	All Models	with clamps;  ASV	<b>LM-10024S</b>		d1=25; d2=41; L [mm]=120
Bellow, steering	All Models	with clamps;  ASV	<b>LM-10050S</b>		d1=25; d2=39; L [mm]=126
Bellow, driveshaft	1.6		<b>M-830220</b>		
Bellow Set, drive shaft	1.6		<b>MK-830220</b>		
Bellow Set, drive shaft	1.6		<b>MK-830220S</b>		

**CORDOBA Vario (6K5) 06/1999 → 12/2002**

Dust Cover Kit, shock absorber	All Models		<b>AK-735029</b>		
Alternator Freewheel Clutch	1.9 SDI, 1.9 TDI		<b>F5-1004</b>		
Repair Kit, link	All Models	with guide sleeve	<b>F8-1008</b>		H1=24; H2=41; d=17; D=60
Stabiliser Mounting	1.4 i, 1.6, 1.6 i		<b>F8-3042</b>		H=33; d=17; W=35
Engine Mounting	1.4 16V, 1.6 i, 1.9 SDI	Brown	<b>F8-5346</b>		



Article Description



Article Nr.

Fitting Position



<b>CORDOBA Vario (6K5)</b>			<b>06/1999 → 12/2002</b>		
Stabiliser Mounting	1.4 16V, 1.9 TDI		<b>F8-5395</b>		d=19
Stabiliser Mounting	1.6	ch.6K-X-430580→	<b>F8-5395</b>		d=19
Stabiliser Mounting	1.6	AUR	<b>F8-5395</b>		d=19
Stabiliser Mounting	1.9 SDI, 1.9 TDI	ch.6K-X-400000→	<b>F8-5395</b>		d=19
Stabiliser Mounting	1.9 TDI	ch.6K-X-400000→;  ASV	<b>F8-5395</b>		d=19
Engine Mounting	1.6	AEH, AKL	<b>F8-5397</b>		
Engine Mounting	1.6, 1.6 i		<b>F8-5397</b>		
Engine Mounting	1.4, 1.4 i		<b>F8-5398</b>		
Top Strut Mounting	1.4, 1.4 16V, 1.6, 1.9 SDI, 1.9 TDI	ch.6K-X-400000→	<b>F8-5402</b>		
Top Strut Mounting	1.9 TDI	ch.6K-X-400000→;  ASV	<b>F8-5402</b>		
Top Strut Mounting	1.4, 1.4 16V, 1.6, 1.9 SDI, 1.9 TDI	ch.6K-X-400000→	<b>F8-5403</b>		
Top Strut Mounting	1.9 TDI	ch.6K-X-400000→;  ASV	<b>F8-5403</b>		
Engine Mounting	1.9 TDI	ch.6K-X-400001→	<b>F8-5491</b>		
Engine Mounting	1.9 TDI	ch.6K-X-400001→;  ASV	<b>F8-5491</b>		
Top Strut Mounting	1.4	ch.6K-X-290000→;  AKK;	<b>F8-5537</b>		
Top Strut Mounting	1.4 16V, 1.9 TDI	ch.6K-X-290000→;	<b>F8-5537</b>		
Top Strut Mounting	1.6	ch.6K-X-290000→;  APF;	<b>F8-5537</b>		
Top Strut Mounting	1.9 TDI	ch.6K-X-290000→;  ASV;	<b>F8-5537</b>		
Engine Mounting	1.4	ANW	<b>F8-5554</b>		H=39.5; d1=16; d2=24; D=50
Engine Mounting	1.4 16V, 1.4 i, 1.6 i		<b>F8-5554</b>		H=39.5; d1=16; d2=24; D=50
Holder, engine mounting	1.6, 1.6 i, 1.9 SDI, 1.9 TDI		<b>F8-5672</b>		H=39.5; D=24
Top Strut Mounting	All Models		<b>F8-6281</b>		
Repair Kit, suspension strut	All Models		<b>F8-6382</b>		
Anti-Friction Bearing	All Models		<b>F8-6569</b>		
Sleeve, control arm mounting	All Models		<b>F8-6699</b>		d=16; L=50; D=17
Engine Mounting	1.4, 1.9 SDI		<b>F8-6922</b>		H=65
Protective Cap/Bellow, shock absorber	All Models		<b>F8-7132</b>		H=190
Bellow, driveshaft	1.6, 1.6 i, 1.9 SDI		<b>F8-7722</b>		d1=26; d2=78; L=110
Mounting, axle beam	All Models		<b>F8-7938</b>		H=80; D=72
Bellow, steering	All Models	with clamps;	<b>LM-10024S</b>		d1=25; d2=41; L [mm]=120
Bellow, steering	All Models	with clamps;	<b>LM-10050S</b>		d1=25; d2=39; L [mm]=126
Bellow, driveshaft	1.4 i, 1.6, 1.6 i, 1.9 SDI		<b>M-830220</b>		
Bellow Set, drive shaft	1.6, 1.6 i, 1.9 SDI		<b>MK-830220</b>		

<b>F8-5395</b>	<b>F8-5397</b>	<b>F8-5398</b>	<b>F8-5402</b>	<b>F8-5403</b>	<b>F8-5491</b>	<b>F8-5537</b>
Ref.Nr.: 1H0411314	Ref.Nr.: 1H0199609F	Ref.Nr.: 1H0199609E	Ref.Nr.: 191512335	Ref.Nr.: 191512333	Ref.Nr.: 357199381	Ref.Nr.: 6N0412331E
<b>F8-5554</b>	<b>F8-5672</b>	<b>F8-6281</b>	<b>F8-6382</b>	<b>F8-6569</b>	<b>F8-6699</b>	<b>F8-6922</b>
Ref.Nr.: 191199233	Ref.Nr.: 1H0199233A	Ref.Nr.: 8Z0412331	Ref.Nr.: 191512333S	Ref.Nr.: 6N0412249C	Ref.Nr.: 191407190A	Ref.Nr.: 191199381A
<b>F8-7132</b>	<b>F8-7722</b>	<b>F8-7938</b>	<b>LM-10024S</b>	<b>LM-10050S</b>	<b>M-830220</b>	<b>MK-830220</b>
Ref.Nr.: 6N0413175A	Ref.Nr.: 191407285F	Ref.Nr.: 6K0501541A	Ref.Nr.: 171419831B	Ref.Nr.: 171419831C	Ref.Nr.: 191498203C	Ref.Nr.: 171498203



**Article Description****Article Nr.****Fitting Position**

<b>CORDOBA Vario (6K5)</b>				<b>06/1999 → 12/2002</b>	
Bellow Set, drive shaft	1.6, 1.6 i, 1.9 SDI		<b>MK-830220S</b>		
<b>CORDOBA (6L2)</b>				<b>09/2002 → 11/2009</b>	
Alternator Freewheel Clutch	1.2		<b>F5-1000</b>		
Alternator Freewheel Clutch	1.4 TDI, 1.9 SDI, 1.9 TDI		<b>F5-1004</b>		
Top Strut Mounting	All Models		<b>F8-5380</b>		
Rubber Buffer, suspension	1.2, 1.4 16V, 1.4 TDI, 1.6, 1.9 SDI, 1.9 TDI, 2.0		<b>F8-5381</b>		H=37; D=76
Engine Mounting	1.4 16V		<b>F8-5532</b>		
Engine Mounting	2.0		<b>F8-5533</b>		
Engine Mounting	1.4 16V		<b>F8-5534</b>		
Engine Mounting	1.4 16V, 1.6		<b>F8-5534</b>		
Engine Mounting	1.9 SDI, 1.9 TDI, 2.0		<b>F8-5535</b>		
Top Strut Mounting	1.2, 1.2 12V, 1.4 16V, 1.4 TDI, 1.6, 1.6 16V, 1.9 SDI, 1.9 TDI, 2.0		<b>F8-5537</b>		
Top Strut Mounting	1.4 16V		<b>F8-5537</b>		
Engine Mounting	1.4 16V		<b>F8-5551</b>		
Belt Pulley, crankshaft	2.0		<b>F8-5650</b>		
Holder, engine mounting	1.6, 1.9 SDI, 1.9 TDI		<b>F8-5672</b>		H=39.5; D=24
Top Strut Mounting	1.2, 1.4 16V, 1.4 TDI, 1.6, 1.9 SDI, 1.9 TDI, 2.0		<b>F8-6040</b>		
Protective Cap/Bellow, shock absorber	All Models	for OE: 1JB;	<b>F8-6044</b>		H=160
Mounting, axle beam	1.2, 1.4 16V, 1.4 TDI, 1.6, 1.9 SDI, 1.9 TDI, 2.0		<b>F8-6076</b>		d=12; L=90; D=69
Repair Set, axle beam	1.2, 1.4 16V, 1.4 TDI, 1.6, 1.9 SDI, 1.9 TDI, 2.0		<b>F8-6077</b>		H=90; D=69
Repair Set, axle beam	1.4 16V		<b>F8-6077</b>		H=90; D=69
Repair Set, axle beam	1.9 TDI		<b>F8-6077</b>		H=90; D=69
Top Strut Mounting	All Models		<b>F8-6281</b>		
Belt Pulley, crankshaft	1.9 TDI	Number of Ribs: 5; Parameter: 6PK	<b>F8-6396</b>		H=41.6; d=30; Mounting points diam.[mm]=7, 8.6; D=139.7
Stabiliser Mounting	All Models	ch.→6L-3-164392	<b>F8-6460</b>		d=18
Stabiliser Mounting	All Models	Stabi. Diam. [mm]= 19	<b>F8-6461</b>		d=17
Stabiliser Mounting	All Models	ch.6L-3-164394→	<b>F8-6462</b>		d=16
Engine Mounting	1.2		<b>F8-6532</b>		
Engine Mounting	1.4 TDI		<b>F8-6533</b>		
Anti-Friction Bearing	All Models		<b>F8-6569</b>		
Belt Pulley, crankshaft	1.9 SDI	Number of Ribs: 5; Parameter: 6PK	<b>F8-6572</b>		
Rubber Buffer, suspension	All Models	for OE: 1JB, 1JR, UB3;	<b>F8-6723</b>		H=124

<b>F5-1000</b>	<b>F5-1004</b>	<b>F8-5380</b>	<b>F8-5381</b>	<b>F8-5532</b>	<b>F8-5533</b>	<b>F8-5534</b>
Ref.Nr.: 03D903119A	Ref.Nr.: 038903119T	Ref.Nr.: 1J0513353G	Ref.Nr.: 1J0512149B	Ref.Nr.: 6Q0199851S	Ref.Nr.: 6Q0199851M	Ref.Nr.: 6Q0199851AB
<b>F8-5535</b>	<b>F8-5537</b>	<b>F8-5551</b>	<b>F8-5650</b>	<b>F8-5672</b>	<b>F8-6040</b>	<b>F8-6044</b>
Ref.Nr.: 6Q0199167BQ	Ref.Nr.: 6N0412331E	Ref.Nr.: 6Q0199167BM	Ref.Nr.: 06A105243E	Ref.Nr.: 1H0199233A	Ref.Nr.: 1J0513353D	Ref.Nr.: 3C0513425
<b>F8-6076</b>	<b>F8-6077</b>	<b>F8-6281</b>	<b>F8-6396</b>	<b>F8-6460</b>	<b>F8-6461</b>	<b>F8-6462</b>
Ref.Nr.: 1J0501541D	Ref.Nr.: 1J0501541DS	Ref.Nr.: 8Z0412331	Ref.Nr.: 03G105243	Ref.Nr.: 6Q0411314R	Ref.Nr.: 6Q0 411 314 M	Ref.Nr.: 6Q0411314L

Article Description



Article Nr.

Fitting Position



<b>CORDOBA (6L2)</b>		<b>09/2002 → 11/2009</b>	
Control Arm-/Trailing Arm Bush	All Models		F8-6736
Engine Mounting	1.4 16V		F8-6752
Engine Mounting	1.6		F8-6986
Protective Cap/Bellow, shock absorber	All Models		F8-7132
Rubber Buffer, suspension	All Models		F8-7675
Rubber Buffer, suspension	All Models		F8-7676
Control Arm-/Trailing Arm Bush	All Models	ch. → 6L-8-157034	F8-7873
Mounting, axle beam	All Models	for OE: 0N7;	F8-7928
Engine Mounting	1.4 16V		F8-7949
Engine Mounting	1.6		F8-7949
Engine Mounting	1.4 TDI		F8-7950
Engine Mounting	1.2, 1.4 16V, 1.6 16V		F8-7951
Engine Mounting	1.4 16V		F8-7951
Engine Mounting	1.4 TDI		F8-7952
Engine Mounting	1.4 16V		F8-7954
Engine Mounting	1.2 12V		F8-7955
Engine Mounting	1.9 TDI		F8-7956
Control Arm-/Trailing Arm Bush	1.2 12V, 1.4 16V, 1.4 TDI, 1.6, 1.6 16V, 1.9 SDI, 1.9 TDI		F8-7978
Belt Pulley, crankshaft	1.4 TDI	Number of Ribs: 5; Parameter: 6PK	F8-8038
Engine Mounting	1.4 16V, 1.4 TDI, 1.6, 1.9 SDI, 2.0		F8-8164
Engine Mounting	1.2, 1.2 12V, 1.4 16V, 1.4 TDI, 1.6, 1.9 SDI, 1.9 TDI, 2.0		F8-8173
Engine Mounting	1.4 16V		F8-8173
Engine Mounting	1.6 16V, 1.9 TDI		F8-8173
<b>EXEO (3R2)</b>		<b>12/2008 → 09/2010</b>	
Alternator Freewheel Clutch	2.0 TDI		F5-1004
Alternator Freewheel Clutch	1.6, 1.8 T, 2.0 TFSI		F5-1044
Alternator Freewheel Clutch	2.0 TDI		F5-1085
Control Arm-/Trailing Arm Bush	All Models		F8-4045
Control Arm-/Trailing Arm Bush	All Models		F8-6151
Top Strut Mounting	All Models		F8-6352
Top Strut Mounting	All Models		F8-7451

<b>F5-1004</b>	<b>F5-1044</b>	<b>F5-1085</b>	<b>F8-4045</b>	<b>F8-6151</b>	<b>F8-6352</b>	<b>F8-6736</b>
Ref.Nr.: 038903119T	Ref.Nr.: 06B903119B	Ref.Nr.: 045903119A	Ref.Nr.: 4D0407182E	Ref.Nr.: 8E0407181B	Ref.Nr.: 4F0513353B	Ref.Nr.: 1K0407183A
<b>F8-6752</b>	<b>F8-6986</b>	<b>F8-7132</b>	<b>F8-7451</b>	<b>F8-7577</b>	<b>F8-7675</b>	<b>F8-7676</b>
Ref.Nr.: 6Q0199167BN	Ref.Nr.: 6Q0199167J	Ref.Nr.: 6N0413175A	Ref.Nr.: 8E0412377C	Ref.Nr.: 8D0 412 131 H	Ref.Nr.: 6Q0412301	Ref.Nr.: 6Q0412301A
<b>F8-7873</b>	<b>F8-7928</b>	<b>F8-7949</b>	<b>F8-7950</b>	<b>F8-7951</b>	<b>F8-7952</b>	<b>F8-7954</b>
Ref.Nr.: 6Q0407182A	Ref.Nr.: 6Q0501541E	Ref.Nr.: 6Q0199851AK	Ref.Nr.: 6Q0199851AQ	Ref.Nr.: 6Q0199555AR	Ref.Nr.: 6Q0199167DH	Ref.Nr.: 6Q0199851AL

**Article Description****Article Nr.****Fitting Position**

<b>EXEO (3R2)</b>			<b>12/2008 → 09/2010</b>		
Rubber Buffer, suspension	1.6, 1.8 T, 2.0 TDI, 2.0 TFSI		<b>F8-7577</b>		H=94
Rubber Buffer, suspension	1.6, 1.8 T, 2.0 TDI, 2.0 TFSI		<b>F8-7578</b>		H=146
Protective Cap/Bellow, shock absorber	All Models		<b>F8-7682</b>		H=160
Protective Cap/Bellow, shock absorber	All Models		<b>F8-7687</b>		H=80
Control Arm-/Trailing Arm Bush	1.6, 1.8 T, 1.8 TSI, 2.0 TFSI		<b>F8-7796</b>		H=40; d=10; D=46,5
Control Arm-/Trailing Arm Bush	2.0 TDI	CAGA	<b>F8-7796</b>		H=40; d=10; D=46,5
Control Arm-/Trailing Arm Bush	2.0 TDI	CAGC	<b>F8-7796</b>		H=40; d=10; D=46,5
Control Arm-/Trailing Arm Bush	2.0 TDI	CAHA	<b>F8-7796</b>		H=40; d=10; D=46,5
Protective Cap/Bellow, shock absorber	All Models	for OE: 1BR; ☆, △	<b>F8-7802</b>		H=156
Belt Pulley, crankshaft	1.8 TSI, 2.0 TFSI	Number of Ribs: 5; Parameter: 6PK	<b>F8-7880</b>		D=143
Control Arm-/Trailing Arm Bush	All Models		<b>F8-8133</b>		H=60; d=12; D=46
Engine Mounting	1.6, 1.8 T, 1.8 TSI, 2.0 TDI		<b>F8-8171</b>		
<b>EXEO ST (3R5)</b>			<b>05/2009 → 09/2010</b>		
Alternator Freewheel Clutch	2.0 TDI		<b>F5-1004</b>		
Alternator Freewheel Clutch	1.6, 1.8 T, 2.0 TFSI		<b>F5-1044</b>		
Alternator Freewheel Clutch	2.0 TDI		<b>F5-1085</b>		
Control Arm-/Trailing Arm Bush	All Models		<b>F8-4045</b>		H1=31; H2=60; d=12; D=50
Control Arm-/Trailing Arm Bush	All Models		<b>F8-6151</b>		d=12; D=40; W=37
Top Strut Mounting	All Models		<b>F8-6352</b>		
Top Strut Mounting	All Models		<b>F8-7451</b>		
Rubber Buffer, suspension	1.6, 1.8 T, 2.0 TDI, 2.0 TFSI		<b>F8-7577</b>		H=94
Rubber Buffer, suspension	1.6, 1.8 T, 2.0 TDI, 2.0 TFSI		<b>F8-7578</b>		H=146
Protective Cap/Bellow, shock absorber	All Models		<b>F8-7682</b>		H=160
Protective Cap/Bellow, shock absorber	All Models		<b>F8-7687</b>		H=80
Control Arm-/Trailing Arm Bush	1.6, 1.8 T, 1.8 TSI, 2.0 TFSI		<b>F8-7796</b>		H=40; d=10; D=46,5
Control Arm-/Trailing Arm Bush	2.0 TDI	CAGA	<b>F8-7796</b>		H=40; d=10; D=46,5
Control Arm-/Trailing Arm Bush	2.0 TDI	CAGC	<b>F8-7796</b>		H=40; d=10; D=46,5

<b>F5-1004</b>	<b>F5-1044</b>	<b>F5-1085</b>	<b>F8-4045</b>	<b>F8-6151</b>	<b>F8-6352</b>	<b>F8-7451</b>
Ref.Nr.: 038903119T	Ref.Nr.: 06B903119B	Ref.Nr.: 045903119A	Ref.Nr.: 4D0407182E	Ref.Nr.: 8E0407181B	Ref.Nr.: 4F0513353B	Ref.Nr.: 8E0412377C
<b>F8-7577</b>	<b>F8-7578</b>	<b>F8-7682</b>	<b>F8-7687</b>	<b>F8-7796</b>	<b>F8-7802</b>	<b>F8-7880</b>
Ref.Nr.: 8D0 412 131 H	Ref.Nr.: 4F0 512 131	Ref.Nr.: 8E0512137E	Ref.Nr.: 4D0412137B	Ref.Nr.: 8D0407515C	Ref.Nr.: 4B0512137B	Ref.Nr.: 06H105243F
<b>F8-8133</b>	<b>F8-8171</b>					
Ref.Nr.: 8E0505203D	Ref.Nr.: 8E0199382J					

Article Description



Article Nr.

Fitting Position



			<b>05/2009 → 09/2010</b>		
<b>EXEO ST (3R5)</b>					
Control Arm-/Trailing Arm Bush	2.0 TDI	CAHA	<b>F8-7796</b>		H=40; d=10; D=46,5
Protective Cap/Bellow, shock absorber	All Models	for OE: 1BR; ☆, △	<b>F8-7802</b>		H=156
Belt Pulley, crankshaft	1.8 TSI, 2.0 TFSI	Number of Ribs: 5; Parameter: 6PK	<b>F8-7880</b>		D=143
Control Arm-/Trailing Arm Bush	All Models		<b>F8-8133</b>		H=60; d=12; D=46
Engine Mounting	1.6, 1.8 T, 1.8 TSI, 2.0 TDI		<b>F8-8171</b>		
			<b>06/1984 → 12/1993</b>		
<b>IBIZA (021A)</b>					
Dust Cover Kit, shock absorber	All Models		<b>AK-735002</b>		
Dust Cover Kit, shock absorber	All Models		<b>AK-735027</b>		
Dust Cover Kit, shock absorber	All Models		<b>AK-735098</b>		
Control Arm-/Trailing Arm Bush	0.9, 1.2, 1.2 i, 1.5, 1.5 i, 1.5 i CAT, 1.7 D	without guide sleeve	<b>F8-1007</b>		H1=26; H2=41; d=17; D1=60; D2=68
Control Arm-/Trailing Arm Bush	0.9, 1.2, 1.2 i, 1.5, 1.5 i, 1.5 i CAT, 1.7 D	with guide sleeve	<b>F8-1007S</b>		H1=26; H2=41; d=17; D1=60; D2=68
Top Strut Mounting	0.9, 1.2, 1.2 i, 1.5, 1.5 i, 1.5 i CAT, 1.7, 1.7 D		<b>F8-1027</b>		H=37; d1=14; d2=20; D=76
Anti-Friction Bearing	1.2, 1.5, 1.7 D		<b>F8-3017</b>		d=50; D=70
Control Arm-/Trailing Arm Bush	All Models		<b>F8-4042</b>		H=44; d=10; D1=38; D2=42
Top Strut Mounting	1.2, 1.5, 1.7 D		<b>F8-5958</b>		
Engine Mounting	0.9, 1.2, 1.2 i, 1.5, 1.5 i, 1.5 i CAT, 1.7 D		<b>F8-6912</b>		
Engine Mounting	0.9	146A.000	<b>F8-6928</b>		
Engine Mounting	0.9, 1.5, 1.5 i, 1.5 i CAT, 1.7 D		<b>F8-6928</b>		
Engine Mounting	1.2	08/1986 →	<b>F8-6928</b>		
			<b>03/1993 → 08/1999</b>		
<b>IBIZA Mk II (6K1)</b>					
Dust Cover Kit, shock absorber	1.0, 1.0 i, 1.3 i, 1.4 i, 1.4 i 16V, 1.6 i, 1.8 i, 1.8 i 16V, 1.9 D, 1.9 SDI, 1.9 TD, 1.9 TDI, 2.0 i		<b>AK-733023</b>		
Dust Cover Kit, shock absorber	1.0, 1.0 i, 1.3 i, 1.4 i, 1.4 i 16V, 1.6 i, 1.8 i, 1.8 i 16V, 1.9 D, 1.9 SDI, 1.9 TD, 1.9 TDI, 2.0 i, 2.0 i 16V		<b>AK-735029</b>		
Alternator Freewheel Clutch	1.9 TDI		<b>F5-1004</b>		
Alternator Freewheel Clutch	1.9 SDI, 1.9 TDI		<b>F5-1007</b>		
Control Arm-/Trailing Arm Bush	1.0, 1.0 i, 1.3 i, 1.4 i, 1.6 i, 1.8 i, 1.8 i 16V, 1.9 D, 1.9 SDI, 1.9 TD, 1.9 TDI, 2.0 i, 2.0 i 16V	without guide sleeve	<b>F8-1007</b>		H1=26; H2=41; d=17; D1=60; D2=68
Control Arm-/Trailing Arm Bush	1.4 i 16V	09/1996 →; without guide sleeve	<b>F8-1007</b>		H1=26; H2=41; d=17; D1=60; D2=68
Control Arm-/Trailing Arm Bush	1.0, 1.0 i, 1.3 i, 1.4 i, 1.4 i 16V, 1.6 i, 1.8 i, 1.8 i 16V, 1.9 D, 1.9 SDI, 1.9 TD, 1.9 TDI, 2.0 i, 2.0 i 16V	with guide sleeve	<b>F8-1007S</b>		H1=26; H2=41; d=17; D1=60; D2=68
Repair Kit, link	1.0, 1.0 i, 1.3 i, 1.4 i, 1.6 i, 1.8 i, 1.8 i 16V, 1.9 D, 1.9 SDI, 1.9 TD, 1.9 TDI, 2.0 i, 2.0 i 16V	with guide sleeve	<b>F8-1008</b>		H1=24; H2=41; d=17; D=60

<b>AK-733023</b>	<b>AK-735002</b>	<b>AK-735027</b>	<b>AK-735029</b>	<b>AK-735098</b>	<b>F5-1004</b>	<b>F5-1007</b>
Ref.Nr.: 191412303	Ref.Nr.:	Ref.Nr.:	Ref.Nr.:	Ref.Nr.:	Ref.Nr.: 038903119T	Ref.Nr.: 028903119AQ
<b>F8-1007</b>	<b>F8-1007S</b>	<b>F8-1008</b>	<b>F8-1027</b>	<b>F8-3017</b>	<b>F8-4042</b>	<b>F8-5958</b>
Ref.Nr.: 191407181A	Ref.Nr.: 191407181A	Ref.Nr.: 191407181E	Ref.Nr.: 811412323D	Ref.Nr.: 4400895	Ref.Nr.: 823407181	Ref.Nr.: 7635775
<b>F8-6912</b>	<b>F8-6928</b>	<b>F8-7796</b>	<b>F8-7802</b>	<b>F8-7880</b>	<b>F8-8133</b>	<b>F8-8171</b>
Ref.Nr.: 4433965	Ref.Nr.: 4433964	Ref.Nr.: 8D0407515C	Ref.Nr.: 4B0512137B	Ref.Nr.: 06H105243F	Ref.Nr.: 8E0505203D	Ref.Nr.: 8E0199382J

**Article Description****Article Nr.****Fitting Position**

<b>IBIZA Mk II (6K1)</b>			<b>03/1993 → 08/1999</b>	
Repair Kit, link	1.4 i 16V	09/1996 →; with guide sleeve	<b>F8-1008</b>	H1=24; H2=41; d=17; D=60
Top Strut Mounting	1.0, 1.0 i, 1.3 i, 1.4 i, 1.4 i 16V, 1.6 i, 1.8 i, 1.9 D, 1.9 SDI, 1.9 TD, 1.9 TDI, 2.0 i 16V		<b>F8-1009B</b>	d=14; D=132
Top Strut Mounting	1.8 i 16V, 2.0 i	ch.→6K-ZR082400, 6K-ZR599964	<b>F8-1009B</b>	d=14; D=132
Engine Mounting	1.4 i 16V, 1.6 i, 1.8 i, 1.9 TDI, 2.0 i 16V		<b>F8-1011</b>	H=133; D1=80; D2=108
Engine Mounting	1.4 i 16V, 1.6 i, 1.8 i, 1.8 i 16V, 1.9 D, 1.9 TD, 2.0 i		<b>F8-1015</b>	H=82; D1=55; D2=71
Top Strut Mounting	1.0 i, 1.4 i 16V, 1.6 i, 1.9 TDI, 2.0 i	01/1997 →;	<b>F8-1034</b>	H=50; d=27; D=98
Top Strut Mounting	1.0, 1.8 i, 1.9 D, 1.9 TD	01/1996 →;	<b>F8-1034</b>	H=50; d=27; D=98
Top Strut Mounting	1.4 i, 1.6 i, 1.9 D, 1.9 SDI, 1.9 TDI, 2.0 i 16V		<b>F8-1034</b>	H=50; d=27; D=98
Top Strut Mounting	1.8 i 16V	01/1994 →;	<b>F8-1034</b>	H=50; d=27; D=98
Top Strut Mounting	1.0 i, 1.4 i 16V, 1.6 i, 1.9 TDI, 2.0 i	01/1997 →;	<b>F8-1034S</b>	H=51; d=14; D=96
Top Strut Mounting	1.0, 1.8 i, 1.9 D, 1.9 TD	01/1996 →;	<b>F8-1034S</b>	H=51; d=14; D=96
Top Strut Mounting	1.4 i, 1.6 i, 1.9 D, 1.9 SDI, 1.9 TDI, 2.0 i 16V		<b>F8-1034S</b>	H=51; d=14; D=96
Top Strut Mounting	1.8 i 16V	01/1994 →;	<b>F8-1034S</b>	H=51; d=14; D=96
Anti-Friction Bearing	1.0, 1.3 i, 1.4 i, 1.4 i 16V, 1.6 i, 1.8 i, 1.8 i 16V, 1.9 D, 1.9 TD, 2.0 i, 2.0 i 16V		<b>F8-3039</b>	H=14; d1=14; D=45
Anti-Friction Bearing	1.9 SDI, 1.9 TDI	ch.→6K-X-399999	<b>F8-3039</b>	H=14; d1=14; D=45
Stabiliser Mounting	1.0 i, 1.4 i 16V, 1.6 i, 1.8 i, 1.9 D, 1.9 SDI, 1.9 TD, 1.9 TDI, 2.0 i, 2.0 i 16V	ch.→6K-V-143400	<b>F8-3042</b>	H=33; d=17; W=35
Stabiliser Mounting	1.0, 1.3 i, 1.4, 1.4 i, 1.6 i, 1.8 i 16V		<b>F8-3042</b>	H=33; d=17; W=35
Flange, carburettor	1.6 i, 1.8 i		<b>F8-3048</b>	H=27; d=40
Engine Mounting	1.9 D, 1.9 TD		<b>F8-3053</b>	H=135; D1=79; D2=93
Engine Mounting	1.9 D, 1.9 SDI, 1.9 TD		<b>F8-4016</b>	
Engine Mounting	1.0, 1.0 i, 1.3 i, 1.4 i		<b>F8-4017</b>	
Rubber Buffer, suspension	1.0, 1.3 i, 1.4 i, 1.6 i, 1.8 i, 1.8 i 16V, 1.9 D, 1.9 TD, 2.0 i		<b>F8-4063</b>	H=83; d1=18; d2=25; D1=48; D2=60
Protective Cap/Bellow, shock absorber	1.0, 1.3 i, 1.4 i, 1.6 i, 1.8 i, 1.9 D, 1.9 TD	ch.→6K-TR080000	<b>F8-4064</b>	H=90; d1=50; d2=71; D1=66; D2=77
Protective Cap/Bellow, shock absorber	1.8 i 16V, 2.0 i	ch.→6K-ZR082400, 6K-ZR599964	<b>F8-4064</b>	H=90; d1=50; d2=71; D1=66; D2=77
Bellow, steering	1.0, 1.0 i, 1.3 i, 1.4 i, 1.4 i 16V, 1.6 i, 1.8 i, 1.8 i 16V, 1.9 D, 1.9 SDI, 1.9 TD, 1.9 TDI, 2.0 i, 2.0 i 16V		<b>F8-4069</b>	
Bellow, steering	1.0, 1.3 i, 1.4 i, 1.6 i, 1.8 i, 1.8 i 16V, 1.9 D, 1.9 SDI, 1.9 TD, 2.0 i		<b>F8-4075</b>	H=200; d=10; D=48
Mounting, steering gear	1.0, 1.0 i, 1.3 i, 1.4 i, 1.4 i 16V, 1.6 i, 1.8 i, 1.8 i 16V, 1.9 D, 1.9 SDI, 1.9 TD, 1.9 TDI, 2.0 i, 2.0 i 16V		<b>F8-5145</b>	d1=50.7; d2=48.3
Engine Mounting	1.6 i, 1.9 SDI	Brown	<b>F8-5346</b>	
Engine Mounting	2.0 i	Brown;  AGG	<b>F8-5346</b>	
Stabiliser Mounting	1.4 i 16V, 1.6 i, 1.9 D, 1.9 SDI, 1.9 TD, 2.0 i 16V	ch.6K-V-143401→	<b>F8-5395</b>	d=19

<b>F8-1008</b>	<b>F8-1009B</b>	<b>F8-1011</b>	<b>F8-1015</b>	<b>F8-1034</b>	<b>F8-1034S</b>	<b>F8-3039</b>
Ref.Nr.: 191407181E	Ref.Nr.: 176412329	Ref.Nr.: 1H0199262F	Ref.Nr.: 357199402	Ref.Nr.: 357412331A	Ref.Nr.: 7201848S1	Ref.Nr.: 357412249A
<b>F8-3042</b>	<b>F8-3048</b>	<b>F8-3053</b>	<b>F8-4016</b>	<b>F8-4017</b>	<b>F8-4063</b>	<b>F8-4064</b>
Ref.Nr.: 191411314	Ref.Nr.: 050129761B	Ref.Nr.: 1H0199609B	Ref.Nr.: 1H0199262G	Ref.Nr.: 1H0199262E	Ref.Nr.: 191412303A	Ref.Nr.: 191412135
<b>F8-4069</b>	<b>F8-4075</b>	<b>F8-5145</b>	<b>F8-5346</b>	<b>F8-5395</b>		
Ref.Nr.: 171419831B	Ref.Nr.: 357422831	Ref.Nr.: 191419883	Ref.Nr.: 1H0199609G	Ref.Nr.: 1H0411314		

Article Description



Article Nr.

Fitting Position



## IBIZA Mk II (6K1)

03/1993 → 08/1999

Stabiliser Mounting	1.6 i	ch.6K-X-430580→;  ALM	<b>F8-5395</b>		d=19
Stabiliser Mounting	1.8 i	ch.6K-V-143401→;  ADZ	<b>F8-5395</b>		d=19
Stabiliser Mounting	1.9 TDI		<b>F8-5395</b>		d=19
Stabiliser Mounting	1.9 TDI	ch.6K-V-143401→;  AHU	<b>F8-5395</b>		d=19
Stabiliser Mounting	2.0 i	ch.6K-V-143401→;  AGG	<b>F8-5395</b>		d=19
Engine Mounting	1.8 i 16V, 1.9 TDI, 2.0 i 16V		<b>F8-5396</b>		
Engine Mounting	1.9 TDI	AHU	<b>F8-5396</b>		
Engine Mounting	2.0 i	2E	<b>F8-5396</b>		
Engine Mounting	1.4 i 16V, 1.6 i, 1.8 i		<b>F8-5397</b>		
Engine Mounting	1.6 i	AEE, ALM	<b>F8-5397</b>		
Engine Mounting	1.0, 1.0 i, 1.3 i, 1.4 i		<b>F8-5398</b>		
Engine Mounting	1.6 i	ABU	<b>F8-5398</b>		
Top Strut Mounting	1.0 i, 1.4 i, 1.4 i 16V, 1.6 i, 1.8 i, 1.9 SDI, 1.9 TDI, 2.0 i, 2.0 i 16V	ch.→6K-X-399999	<b>F8-5402</b>		
Top Strut Mounting	1.0, 1.3 i, 1.8 i 16V, 1.9 TD		<b>F8-5402</b>		
Top Strut Mounting	1.0 i, 1.4 i, 1.4 i 16V, 1.6 i, 1.8 i, 1.9 SDI, 1.9 TDI, 2.0 i, 2.0 i 16V	ch.→6K-X-399999	<b>F8-5403</b>		
Top Strut Mounting	1.0, 1.3 i, 1.8 i 16V, 1.9 TD		<b>F8-5403</b>		
Engine Mounting	1.9 TDI		<b>F8-5491</b>		
Engine Mounting	1.0, 1.3 i, 1.4 i, 1.4 i 16V, 1.6 i, 1.8 i, 1.9 D, 1.9 TD		<b>F8-5554</b>		H=39.5; d1=16; d2=24; D=50
Belt Pulley, crankshaft	1.9 D, 1.9 SDI, 1.9 TD, 1.9 TDI	Number of Ribs: 5; Parameter: 6PK	<b>F8-5649</b>		H=31.5; d=30.02; Mounting points diam.[mm]=8.5; D1=161.5; D2=160.5
Holder, engine mounting	1.6 i, 1.9 SDI, 1.9 TDI		<b>F8-5672</b>		H=39.5; D=24
Rubber Buffer, suspension	1.0, 1.3 i, 1.4 i, 1.6 i, 1.8 i, 1.9 D	02/1996 →	<b>F8-5993</b>		H=83
Rubber Buffer, suspension	1.6 i, 1.9 SDI		<b>F8-5993</b>		H=83
Rubber Buffer, suspension	1.8 i 16V, 2.0 i	06/1994 →	<b>F8-5993</b>		H=83
Repair Kit, suspension strut	1.0, 1.0 i, 1.3 i, 1.4 i, 1.4 i 16V, 1.6 i, 1.8 i, 1.8 i 16V, 1.9 D, 1.9 SDI, 1.9 TD, 1.9 TDI, 2.0 i, 2.0 i 16V		<b>F8-6382</b>		
Anti-Friction Bearing	1.9 SDI, 1.9 TDI	ch.6K-X-400000→	<b>F8-6569</b>		
Sleeve, control arm mounting	1.0, 1.0 i, 1.3 i, 1.4 i, 1.4 i 16V, 1.6 i, 1.8 i, 1.8 i 16V, 1.9 D, 1.9 SDI, 1.9 TD, 1.9 TDI, 2.0 i, 2.0 i 16V		<b>F8-6699</b>		d=16; L=50; D=17
Engine Mounting	1.0 i, 1.4 i, 1.9 SDI	ch.→6K-X-399999	<b>F8-6922</b>		H=65
Engine Mounting	1.0, 1.3 i		<b>F8-6922</b>		H=65
Engine Mounting	1.6 i	ch.→6K-X-399999;  AEE	<b>F8-6922</b>		H=65
Bellow, driveshaft	1.0, 1.0 i, 1.4 i 16V, 1.6 i, 1.9 D, 1.9 SDI		<b>F8-7722</b>		d1=26; d2=78; L=110
Bellow, driveshaft	1.3 i	AAV	<b>F8-7722</b>		d1=26; d2=78; L=110



**Article Description****Article Nr.****Fitting Position****IBIZA Mk II (6K1) 03/1993 → 08/1999**

Bellow, driveshaft	1.4 i	ABD, AEX	<b>F8-7722</b>		d1=26; d2=78; L=110
Bellow, driveshaft	1.6 i	ABU, AEE	<b>F8-7722</b>		d1=26; d2=78; L=110
Control Arm-/Trailing Arm Bush	All Models		<b>F8-7978</b>		
Control Arm-/Trailing Arm Bush	1.0, 1.0 i, 1.3 i, 1.4 i, 1.6 i, 1.8 i, 1.8 i 16V, 1.9 D, 1.9 SDI, 1.9 TD, 1.9 TDI, 2.0 i, 2.0 i 16V		<b>G9-648</b>		H=54; d=12; D1=33; D2=36
Control Arm-/Trailing Arm Bush	1.4 i 16V	09/1996 →	<b>G9-648</b>		H=54; d=12; D1=33; D2=36
Bellow, steering	All Models	with clamps;	<b>LM-10003S</b>		d1=9; d2=43; L [mm]=210
Bellow, steering	All Models	with clamps;	<b>LM-10006S</b>		d1=10; d2=41; L [mm]=210
Bellow, steering	All Models	with clamps;	<b>LM-10024S</b>		d1=25; d2=41; L [mm]=120
Bellow, steering	All Models	with clamps;	<b>LM-10050S</b>		d1=25; d2=39; L [mm]=126
Bellow, driveshaft	1.0, 1.0 i, 1.3 i, 1.4 i, 1.4 i 16V, 1.6 i, 1.9 D, 1.9 SDI		<b>M-830220</b>		
Bellow Set, drive shaft	1.0, 1.0 i, 1.3 i, 1.4 i 16V, 1.6 i, 1.9 D, 1.9 SDI		<b>MK-830220</b>		
Bellow Set, drive shaft	1.4 i	ABD, AEX	<b>MK-830220</b>		
Bellow Set, drive shaft	1.0, 1.0 i, 1.4 i 16V, 1.6 i, 1.9 D, 1.9 SDI		<b>MK-830220S</b>		

**IBIZA Mk III (6K1) 08/1999 → 02/2002**

Dust Cover Kit, shock absorber	All Models		<b>AK-735004</b>		
Dust Cover Kit, shock absorber	All Models		<b>AK-735029</b>		
Alternator Freewheel Clutch	1.9 SDI, 1.9 TDI		<b>F5-1004</b>		
Control Arm-/Trailing Arm Bush	1.4, 1.4 16V, 1.6, 1.8 T 20V Cupra, 1.9 SDI, 1.9 TDI	without guide sleeve	<b>F8-1007</b>		H1=26; H2=41; d=17; D1=60; D2=68
Control Arm-/Trailing Arm Bush	1.4, 1.4 16V, 1.6, 1.8 T 20V Cupra, 1.9 SDI, 1.9 TDI	with guide sleeve	<b>F8-1007S</b>		H1=26; H2=41; d=17; D1=60; D2=68
Repair Kit, link	1.0, 1.4, 1.4 16V, 1.6, 1.8 T 20V Cupra, 1.9 SDI, 1.9 TDI	with guide sleeve	<b>F8-1008</b>		H1=24; H2=41; d=17; D=60
Stabiliser Mounting	1.0, 1.4, 1.6		<b>F8-3042</b>		H=33; d=17; W=35
Engine Mounting	1.4 16V	Brown	<b>F8-5346</b>		
Engine Mounting	1.4 16V	Brown;  AQQ	<b>F8-5346</b>		
Stabiliser Mounting	1.0 16V	AVZ	<b>F8-5395</b>		d=19
Stabiliser Mounting	1.4 16V, 1.6, 1.8 T 20V Cupra		<b>F8-5395</b>		d=19
Stabiliser Mounting	1.6	ch.6K-X-430580→	<b>F8-5395</b>		d=19
Engine Mounting	1.6		<b>F8-5397</b>		
Engine Mounting	1.6	AEH, AKL, APF	<b>F8-5397</b>		
Engine Mounting	1.0	ALD, ANV	<b>F8-5398</b>		
Engine Mounting	1.4	AKK, ANW	<b>F8-5398</b>		
Top Strut Mounting	1.0 16V, 1.8 T 20V Cupra	ch.→6K-2-199999	<b>F8-5402</b>		

<b>AK-735004</b>	<b>AK-735029</b>	<b>F5-1004</b>	<b>F8-1007</b>	<b>F8-1007S</b>	<b>F8-1008</b>	<b>F8-3042</b>
Ref.Nr.:	Ref.Nr.:	Ref.Nr.: 038903119T	Ref.Nr.: 191407181A	Ref.Nr.: 191407181A	Ref.Nr.: 191407181E	Ref.Nr.: 191411314
<b>F8-5346</b>	<b>F8-5395</b>	<b>F8-5397</b>	<b>F8-5398</b>	<b>F8-5402</b>	<b>F8-7722</b>	<b>F8-7978</b>
Ref.Nr.: 1H0199609G	Ref.Nr.: 1H0411314	Ref.Nr.: 1H0199609F	Ref.Nr.: 1H0199609E	Ref.Nr.: 191512335	Ref.Nr.: 191407285F	Ref.Nr.: 357407182F
<b>G9-648</b>	<b>LM-10003S</b>	<b>LM-10006S</b>	<b>LM-10024S</b>	<b>LM-10050S</b>	<b>M-830220</b>	<b>MK-830220</b>
Ref.Nr.: 357407182	Ref.Nr.: 357422831A	Ref.Nr.: 1H0422831B	Ref.Nr.: 171419831B	Ref.Nr.: 171419831C	Ref.Nr.: 191498203C	Ref.Nr.: 171498203

Article Description



Article Nr.

Fitting Position



**IBIZA Mk III (6K1)**

08/1999 → 02/2002

Top Strut Mounting	1.0, 1.4, 1.4 16V, 1.6, 1.9 SDI	ch.6K-X-400000→; ch.→6K-2-199999	<b>F8-5402</b>		
Top Strut Mounting	1.4 16V		<b>F8-5402</b>		
Top Strut Mounting	1.9 TDI	ch.6K-X-400000→; ch.→6K-2-199999; AGR, ALH	<b>F8-5402</b>		
Top Strut Mounting	1.9 TDI	ch.6K-X-400000→; ch.→6K-2-199999; ASV	<b>F8-5402</b>		
Top Strut Mounting	1.0 16V, 1.8 T 20V Cupra	ch.→6K-2-199999	<b>F8-5403</b>		
Top Strut Mounting	1.0, 1.4, 1.4 16V, 1.6, 1.9 SDI	ch.6K-X-400000→; ch.→6K-2-199999	<b>F8-5403</b>		
Top Strut Mounting	1.4 16V		<b>F8-5403</b>		
Top Strut Mounting	1.9 TDI	ch.6K-X-400000→; ch.→6K-2-199999; AGR, ALH	<b>F8-5403</b>		
Top Strut Mounting	1.9 TDI	ch.6K-X-400000→; ch.→6K-2-199999; ASV	<b>F8-5403</b>		
Engine Mounting	1.9 TDI	ch.6K-X-400001→; ch.→6K-2-199999	<b>F8-5491</b>		
Engine Mounting	1.9 TDI	ch.6K-X-400001→; ch.→6K-2-199999; ASV	<b>F8-5491</b>		
Top Strut Mounting	1.0 16V	AVZ;	<b>F8-5537</b>		
Top Strut Mounting	1.0, 1.4, 1.4 16V, 1.6, 1.8 T 20V Cupra, 1.9 SDI, 1.9 TDI		<b>F8-5537</b>		
Top Strut Mounting	1.9 TDI	ASV;	<b>F8-5537</b>		
Engine Mounting	1.0	ALD, ANV	<b>F8-5554</b>		H=39.5; d1=16; d2=24; D=50
Engine Mounting	1.4	AKK, ANW	<b>F8-5554</b>		H=39.5; d1=16; d2=24; D=50
Engine Mounting	1.4 16V	APE	<b>F8-5554</b>		H=39.5; d1=16; d2=24; D=50
Engine Mounting	1.4 16V	AQQ	<b>F8-5554</b>		H=39.5; d1=16; d2=24; D=50
Engine Mounting	1.6		<b>F8-5554</b>		H=39.5; d1=16; d2=24; D=50
Belt Pulley, crankshaft	1.8 T 20V Cupra		<b>F8-5650</b>		
Top Strut Mounting	All Models		<b>F8-6281</b>		
Repair Kit, suspension strut	All Models		<b>F8-6382</b>		
Anti-Friction Bearing	All Models		<b>F8-6569</b>		
Sleeve, control arm mounting	All Models		<b>F8-6699</b>		d=16; L=50; D=17
Engine Mounting	1.0	ch.→6K-2-199999;  ALD, ANV	<b>F8-6922</b>		H=65
Engine Mounting	1.4, 1.9 SDI	ch.→6K-2-199999	<b>F8-6922</b>		H=65
Protective Cap/Bellow, shock absorber	All Models		<b>F8-7132</b>		H=190
Bellow, driveshaft	1.6		<b>F8-7722</b>		d1=26; d2=78; L=110
Mounting, axle beam	All Models		<b>F8-7938</b>		H=80; D=72
Control Arm-/Trailing Arm Bush	All Models		<b>F8-7978</b>		

<b>F8-5402</b>	<b>F8-5403</b>	<b>F8-5491</b>	<b>F8-5537</b>	<b>F8-5554</b>	<b>F8-5650</b>	<b>F8-6281</b>
Ref.Nr.: 191512335	Ref.Nr.: 191512333	Ref.Nr.: 357199381	Ref.Nr.: 6N0412331E	Ref.Nr.: 191199233	Ref.Nr.: 06A105243E	Ref.Nr.: 8Z0412331
<b>F8-6382</b>	<b>F8-6569</b>	<b>F8-6699</b>	<b>F8-6922</b>	<b>F8-7132</b>	<b>F8-7722</b>	<b>F8-7938</b>
Ref.Nr.: 191512333S	Ref.Nr.: 6N0412249C	Ref.Nr.: 191407190A	Ref.Nr.: 191199381A	Ref.Nr.: 6N0413175A	Ref.Nr.: 191407285F	Ref.Nr.: 6K0501541A
<b>F8-7978</b>	<b>G9-648</b>					
Ref.Nr.: 357407182F	Ref.Nr.: 357407182					



**Article Description****Article Nr.****Fitting Position**

<b>IBIZA Mk III (6K1)</b>				<b>08/1999 → 02/2002</b>	
Control Arm-/Trailing Arm Bush	1.0, 1.4, 1.4 16V, 1.6, 1.8 T 20V Cupra, 1.9 SDI, 1.9 TDI		<b>G9-648</b>		H=54; d=12; D1=33; D2=36
Bellow, steering	All Models	with clamps;	<b>LM-10003S</b>		d1=9; d2=43; L [mm]=210
Bellow, steering	All Models	with clamps;	<b>LM-10006S</b>		d1=10; d2=41; L [mm]=210
Bellow, steering	All Models	with clamps;	<b>LM-10024S</b>		d1=25; d2=41; L [mm]=120
Bellow, steering	All Models	with clamps;	<b>LM-10050S</b>		d1=25; d2=39; L [mm]=126
Bellow, driveshaft	1.6		<b>M-830220</b>		
Bellow Set, drive shaft	1.6		<b>MK-830220</b>		
Bellow Set, drive shaft	1.6		<b>MK-830220S</b>		
<b>IBIZA Mk IV (6L1)</b>				<b>02/2002 → 11/2009</b>	
Dust Cover Kit, shock absorber	1.2, 1.2 12V, 1.4 16V, 1.4 TDI, 1.6, 1.6 16V, 1.8 T Cupra R, 1.8 T FR, 1.9 SDI, 1.9 TDI, 1.9 TDI Cupra R, 2.0		<b>AK-735004</b>		
Dust Cover Kit, shock absorber	1.2, 1.2 12V, 1.4 16V, 1.4 TDI, 1.6, 1.6 16V, 1.8 T Cupra R, 1.8 T FR, 1.9 SDI, 1.9 TDI, 1.9 TDI Cupra R, 2.0		<b>AK-735029</b>		
Alternator Freewheel Clutch	1.2		<b>F5-1000</b>		
Alternator Freewheel Clutch	1.4 TDI, 1.9 SDI, 1.9 TDI, 1.9 TDI Cupra R		<b>F5-1004</b>		
Alternator Freewheel Clutch	1.4 TDI		<b>F5-1085</b>		
Top Strut Mounting	1.2, 1.2 12V, 1.4 16V, 1.4 TDI, 1.6 16V, 2.0	<b>ST</b>	<b>F8-5380</b>		
Top Strut Mounting	1.2, 1.4 16V, 1.4 TDI, 1.6, 1.9 SDI, 1.9 TDI	not for equipment variant: 1JF, UB2	<b>F8-5380</b>		
Top Strut Mounting	1.8 T Cupra R, 1.9 TDI Cupra R	<b>ST</b>	<b>F8-5380</b>		
Rubber Buffer, suspension	1.2, 1.4 16V, 1.4 TDI, 1.6, 1.8 T Cupra R, 1.8 T FR, 1.9 SDI, 1.9 TDI, 1.9 TDI Cupra R, 2.0		<b>F8-5381</b>		H=37; D=76
Engine Mounting	1.4 16V		<b>F8-5532</b>		
Engine Mounting	1.4 16V, 1.6, 1.6 16V		<b>F8-5534</b>		
Engine Mounting	1.9 SDI, 1.9 TDI, 2.0		<b>F8-5535</b>		
Top Strut Mounting	1.2	AZQ;	<b>F8-5537</b>		
Top Strut Mounting	1.4 16V	AUB;	<b>F8-5537</b>		
Top Strut Mounting	1.4 16V	BBY;	<b>F8-5537</b>		
Top Strut Mounting	1.9 SDI		<b>F8-5537</b>		
Top Strut Mounting	1.9 TDI	ATD;	<b>F8-5537</b>		
Engine Mounting	1.4 16V		<b>F8-5551</b>		
Belt Pulley, crankshaft	1.8 T Cupra R, 1.8 T FR		<b>F8-5650</b>		
Top Strut Mounting	All Models	<b>SP</b>	<b>F8-6040</b>		
Protective Cap/Bellow, shock absorber	All Models	for OE: 1JB;	<b>F8-6044</b>		H=160

<b>AK-735004</b>	<b>AK-735029</b>	<b>F5-1000</b>	<b>F5-1004</b>	<b>F5-1085</b>	<b>F8-5380</b>	<b>F8-5381</b>
Ref.Nr.:	Ref.Nr.:	Ref.Nr.: 03D903119A	Ref.Nr.: 038903119T	Ref.Nr.: 045903119A	Ref.Nr.: 1J0513353G	Ref.Nr.: 1J0512149B
<b>F8-5532</b>	<b>F8-5534</b>	<b>F8-5535</b>	<b>F8-5537</b>	<b>F8-5551</b>	<b>F8-5650</b>	<b>F8-6040</b>
Ref.Nr.: 6Q0199851S	Ref.Nr.: 6Q0199851AB	Ref.Nr.: 6Q0199167BQ	Ref.Nr.: 6N0412331E	Ref.Nr.: 6Q0199167BM	Ref.Nr.: 06A105243E	Ref.Nr.: 1J0513353D
<b>F8-6044</b>	<b>F8-6076</b>	<b>G9-648</b>	<b>LM-10003S</b>	<b>LM-10006S</b>	<b>LM-10024S</b>	<b>LM-10050S</b>
Ref.Nr.: 3C0513425	Ref.Nr.: 1J0501541D	Ref.Nr.: 357407182	Ref.Nr.: 357422831A	Ref.Nr.: 1H0422831B	Ref.Nr.: 171419831B	Ref.Nr.: 171419831C

Article Description



Article Nr.

Fitting Position



**IBIZA Mk IV (6L1)**

02/2002 → 11/2009

Mounting, axle beam	1.2, 1.4 16V, 1.4 TDI, 1.6, 1.8 T Cupra R, 1.8 T FR, 1.9 SDI, 1.9 TDI, 1.9 TDI Cupra R, 2.0		<b>F8-6076</b>		d=12; L=90; D=69
Repair Set, axle beam	1.2	AZQ	<b>F8-6077</b>		H=90; D=69
Repair Set, axle beam	1.4 16V, 1.4 TDI, 1.6, 1.8 T FR, 1.9 SDI, 1.9 TDI, 1.9 TDI Cupra R		<b>F8-6077</b>		H=90; D=69
Repair Set, axle beam	1.8 T Cupra R	BBU	<b>F8-6077</b>		H=90; D=69
Repair Set, axle beam	1.9 TDI	ATD	<b>F8-6077</b>		H=90; D=69
Repair Set, axle beam	2.0	AZL	<b>F8-6077</b>		H=90; D=69
Top Strut Mounting	1.2, 1.2 12V, 1.4 16V, 1.4 TDI, 1.6 16V, 1.8 T FR, 1.9 TDI Cupra R, 2.0		<b>F8-6281</b>		
Top Strut Mounting	1.2, 1.4 16V, 1.4 TDI, 1.6, 1.9 SDI, 1.9 TDI	not for equipment variant: G03, G19, G21;	<b>F8-6281</b>		
Belt Pulley, crankshaft	1.9 TDI	ASZ; Number of Ribs: 5; Parameter: 6PK	<b>F8-6396</b>		H=41.6; d=30; Mounting points diam.[mm]=7, 8.6; D=139.7
Belt Pulley, crankshaft	1.9 TDI	ATD, BMT; Number of Ribs: 5; Parameter: 6PK	<b>F8-6396</b>		H=41.6; d=30; Mounting points diam.[mm]=7, 8.6; D=139.7
Belt Pulley, crankshaft	1.9 TDI Cupra R	Number of Ribs: 5; Parameter: 6PK	<b>F8-6396</b>		H=41.6; d=30; Mounting points diam.[mm]=7, 8.6; D=139.7
Stabiliser Mounting	All Models	ch.→6L-3-164392	<b>F8-6460</b>		d=18
Stabiliser Mounting	All Models	Stabi. Diam. [mm]= 19	<b>F8-6461</b>		d=17
Stabiliser Mounting	All Models	ch.6L-3-164394→	<b>F8-6462</b>		d=16
Engine Mounting	1.2, 1.2 12V		<b>F8-6532</b>		
Engine Mounting	1.4 TDI		<b>F8-6533</b>		
Anti-Friction Bearing	All Models		<b>F8-6569</b>		
Belt Pulley, crankshaft	1.9 SDI	Number of Ribs: 5; Parameter: 6PK	<b>F8-6572</b>		
Rubber Buffer, suspension	1.2, 1.2 12V, 1.4 16V, 1.4 TDI, 1.6, 1.6 16V, 1.9 TDI	for OE: 1JB, 1JR, UB3;	<b>F8-6723</b>		H=124
Rubber Buffer, suspension	1.2, 1.4 TDI, 1.9 SDI, 2.0		<b>F8-6723</b>		H=124
Control Arm-/Trailing Arm Bush	1.2, 1.2 12V, 1.4 16V, 1.4 TDI, 1.6, 1.6 16V, 1.8 T Cupra R, 1.8 T FR, 1.9 SDI, 1.9 TDI, 1.9 TDI Cupra R		<b>F8-6736</b>		
Engine Mounting	1.4 16V		<b>F8-6752</b>		
Engine Mounting	1.6		<b>F8-6986</b>		
Protective Cap/Bellow, shock absorber	All Models		<b>F8-7132</b>		H=190
Control Arm-/Trailing Arm Bush	1.9 TDI Cupra R	Aluminium	<b>F8-7448</b>		d1=18; d2=20; D=62; W=41
Rubber Buffer, suspension	1.2, 1.2 12V, 1.4 16V, 1.4 TDI, 1.6, 1.6 16V, 1.8 T Cupra R, 1.9 SDI, 1.9 TDI, 1.9 TDI Cupra R, 2.0		<b>F8-7675</b>		H=84
Rubber Buffer, suspension	1.2, 1.2 12V, 1.4 16V, 1.4 TDI, 1.6, 1.6 16V, 1.8 T FR, 1.9 SDI, 1.9 TDI, 2.0		<b>F8-7676</b>		H=56
Control Arm-/Trailing Arm Bush	All Models		<b>F8-7873</b>		



**Article Description****Article Nr.****Fitting Position**

<b>IBIZA Mk IV (6L1)</b>		<b>02/2002 → 11/2009</b>		
Mounting, axle beam	1.2, 1.2 12V, 1.4 16V, 1.4 TDI, 1.6, 1.6 16V, 1.8 T FR, 1.9 SDI, 1.9 TDI, 1.9 TDI Cupra R, 2.0	for OE: 0N7; <b>HD</b>	<b>F8-7928</b>	
Engine Mounting	1.4 16V, 1.6, 1.6 16V		<b>F8-7949</b>	
Engine Mounting	1.4 TDI		<b>F8-7950</b>	
Engine Mounting	1.2, 1.2 12V, 1.4 16V, 1.6 16V		<b>F8-7951</b>	
Engine Mounting	1.4 TDI		<b>F8-7952</b>	
Engine Mounting	1.4 16V		<b>F8-7954</b>	
Engine Mounting	1.2, 1.2 12V		<b>F8-7955</b>	
Engine Mounting	1.8 T Cupra R, 1.8 T FR, 1.9 TDI		<b>F8-7956</b>	
Control Arm-/Trailing Arm Bush	1.2, 1.2 12V, 1.4 16V, 1.4 TDI, 1.6, 1.6 16V, 1.8 T FR, 1.9 TDI, 2.0		<b>F8-7978</b>	
Belt Pulley, crankshaft	1.4 TDI	ch.6L-2-000001-→; Number of Ribs: 5; Parameter: 6PK	<b>F8-8038</b>	
Belt Pulley, crankshaft	1.4 TDI	Number of Ribs: 5; Parameter: 6PK	<b>F8-8038</b>	
Engine Mounting	1.4 16V, 1.4 TDI, 1.6, 1.9 SDI, 2.0		<b>F8-8164</b>	
Engine Mounting	1.2, 1.2 12V, 1.4 16V, 1.4 TDI, 1.6, 1.8 T FR, 1.9 SDI, 1.9 TDI, 1.9 TDI Cupra R, 2.0	6-speed	<b>F8-8173</b>	
Engine Mounting	1.6 16V, 1.9 TDI		<b>F8-8173</b>	
Engine Mounting	1.8 T Cupra R	BBU;  6-speed	<b>F8-8173</b>	
<b>IBIZA V (6J5, 6P1)</b>		<b>03/2008 → 06/2010</b>		
Dust Cover Kit, shock absorber	1.2, 1.2 TDI, 1.2 TSI, 1.4, 1.4 TDI, 1.4 TSI, 1.6, 1.6 LPG, 1.6 TDI, 1.9 TDI, 2.0, 2.0 TDI	<b>ST</b>	<b>AK-735410</b>	H=210
Alternator Freewheel Clutch	1.2 TDI, 1.2 TSI, 1.4 TDI, 1.4 TSI, 1.6 TDI, 1.9 TDI, 2.0, 2.0 TDI		<b>F5-1004</b>	
Alternator Freewheel Clutch	1.2 TSI, 1.4 TSI, 1.6 LPG, 1.6 TDI, 2.0 TDI		<b>F5-1064</b>	
Alternator Freewheel Clutch	1.2, 1.4 TDI, 1.9 TDI		<b>F5-1085</b>	
Anti-Friction Bearing	1.2, 1.2 TDI, 1.2 TSI, 1.4, 1.4 TDI, 1.4 TSI, 1.6, 1.6 LPG, 1.6 TDI, 1.9 TDI, 2.0, 2.0 TDI		<b>F8-3039</b>	H=14; d1=14; D=45
Top Strut Mounting	1.2, 1.4, 1.4 TDI, 1.6, 1.9 TDI		<b>F8-4067</b>	H=53; d=26; D=82
Top Strut Mounting	1.2, 1.2 TDI, 1.2 TSI, 1.4, 1.4 TDI, 1.4 TSI, 1.6, 1.6 TDI, 1.9 TDI, 2.0, 2.0 TDI		<b>F8-5380</b>	
Rubber Buffer, suspension	1.2, 1.2 TDI, 1.2 TSI, 1.4, 1.4 TDI, 1.4 TSI, 1.6, 1.6 LPG, 1.6 TDI, 1.9 TDI, 2.0, 2.0 TDI		<b>F8-5381</b>	H=37; D=76
Engine Mounting	1.4		<b>F8-5534</b>	
Engine Mounting	1.6		<b>F8-5534</b>	
Protective Cap/Bellow, shock absorber	1.2, 1.2 TDI, 1.2 TSI, 1.4, 1.4 TDI, 1.4 TSI, 1.6, 1.6 LPG, 1.6 TDI, 1.9 TDI, 2.0, 2.0 TDI		<b>F8-5683</b>	H=210
Rubber Buffer, suspension	1.2, 1.2 TDI, 1.2 TSI, 1.4, 1.4 TDI, 1.4 TSI, 1.6, 1.6 LPG, 1.6 TDI, 1.9 TDI, 2.0, 2.0 TDI	for OE: G18, G20	<b>F8-5996</b>	H=63
Top Strut Mounting	1.2, 1.4, 1.4 TDI, 1.6, 1.9 TDI, 2.0	<b>SP</b>	<b>F8-6040</b>	

<b>AK-735410</b>	<b>F5-1004</b>	<b>F5-1064</b>	<b>F5-1085</b>	<b>F8-3039</b>	<b>F8-4067</b>	<b>F8-5380</b>
Ref.Nr.: 1J0412303	Ref.Nr.: 038903119T	Ref.Nr.: 03C903119D	Ref.Nr.: 045903119A	Ref.Nr.: 357412249A	Ref.Nr.: 1J0412331B	Ref.Nr.: 1J0513353G
<b>F8-5381</b>	<b>F8-5534</b>	<b>F8-5683</b>	<b>F8-5996</b>	<b>F8-6040</b>	<b>F8-6041</b>	<b>F8-7928</b>
Ref.Nr.: 1J0512149B	Ref.Nr.: 6Q0199851AB	Ref.Nr.: 357413175A	Ref.Nr.: 1H0412303B	Ref.Nr.: 1J0513353D	Ref.Nr.: 1J0412303	Ref.Nr.: 6Q0501541E
<b>F8-7949</b>	<b>F8-7950</b>	<b>F8-7951</b>	<b>F8-7952</b>	<b>F8-7954</b>	<b>F8-7955</b>	<b>F8-7956</b>
Ref.Nr.: 6Q0199851AK	Ref.Nr.: 6Q0199851AQ	Ref.Nr.: 6Q0199555AR	Ref.Nr.: 6Q0199167DH	Ref.Nr.: 6Q0199851AL	Ref.Nr.: 6Q0199851AJ	Ref.Nr.: 6Q0199851AP

Article Description



Article Nr.

Fitting Position



IBIZA V (6J5, 6P1)		03/2008 → 06/2010			
Rubber Buffer, suspension	1.2, 1.2 TDI, 1.2 TSI, 1.4, 1.4 TDI, 1.4 TSI, 1.6, 1.6 LPG, 1.6 TDI, 2.0, 2.0 TDI	for OE: G17, G19, G21, G24	<b>F8-6041</b>		H=53
Rubber Buffer, suspension	1.2, 1.4, 1.6 TDI, 1.9 TDI	for OE: G17, G19	<b>F8-6041</b>		H=53
Protective Cap/Bellow, shock absorber	1.2, 1.2 TDI, 1.2 TSI, 1.4, 1.4 TDI, 1.4 TSI, 1.6, 1.6 LPG, 1.6 TDI, 1.9 TDI, 2.0, 2.0 TDI	for OE: UB9; <b>SP</b>	<b>F8-6044</b>		H=160
Top Strut Mounting	1.2, 1.4, 1.4 TDI, 1.6, 1.9 TDI		<b>F8-6280</b>		H=53; d=26; D=82
Belt Pulley, crankshaft	1.9 TDI	Number of Ribs: 5; Parameter: 6PK	<b>F8-6396</b>		H=41.6; d=30; Mounting points diam.[mm]=7, 8.6; D=139.7
Stabiliser Mounting	1.2, 1.9 TDI	ch.6L-3-164394→	<b>F8-6462</b>		d=16
Control Arm-/Trailing Arm Bush	1.2, 1.2 TDI, 1.4, 1.4 TDI, 1.4 TSI, 1.6, 1.6 TDI, 1.9 TDI, 2.0, 2.0 TDI		<b>F8-6464</b>		H=41; d=13.5; W=60
Belt Pulley, crankshaft	1.2 TDI, 1.6 TDI, 2.0 TDI	Number of Ribs: 5; Parameter: 6PK	<b>F8-6572</b>		
Belt Pulley, crankshaft	1.6 TDI	CAYC; Number of Ribs: 5; Parameter: 6PK	<b>F8-6572</b>		
Top Strut Mounting	1.2, 1.2 TDI, 1.2 TSI, 1.4, 1.4 TDI, 1.4 TSI, 1.6, 1.6 LPG, 1.6 TDI, 1.9 TDI, 2.0, 2.0 TDI	for OE: 1J0412319C	<b>F8-7133</b>		
Protective Cap/Bellow, shock absorber	1.2, 1.2 TDI, 1.2 TSI, 1.4, 1.4 TDI, 1.4 TSI, 1.6, 1.6 TDI, 1.9 TDI, 2.0, 2.0 TDI	<b>SP, ST</b>	<b>F8-7338</b>		
Rubber Buffer, suspension	1.2, 1.2 TDI, 1.4, 1.4 TDI, 1.4 TSI, 1.6, 1.6 TDI, 1.9 TDI, 2.0, 2.0 TDI	for OE: 1JC, 1JS; <b>SP</b>	<b>F8-7658</b>		H=114
Mounting, axle beam	1.2, 1.2 TDI, 1.2 TSI, 1.4, 1.4 TDI, 1.4 TSI, 1.6, 1.6 TDI, 1.9 TDI, 2.0, 2.0 TDI	for OE: 0N7; <b>HD</b>	<b>F8-7928</b>		
Engine Mounting	1.6		<b>F8-7949</b>		
Engine Mounting	1.2	BZG;	<b>F8-7951</b>		
Engine Mounting	1.2, 1.2 TSI		<b>F8-7951</b>		
Engine Mounting	1.4	BXW;	<b>F8-7951</b>		
Engine Mounting	1.2		<b>F8-7955</b>		
Engine Mounting	1.9 TDI		<b>F8-7956</b>		
Engine Mounting	1.4 TDI, 1.6, 1.6 LPG, 2.0		<b>F8-8164</b>		
Engine Mounting	1.2	BZG	<b>F8-8173</b>		
Engine Mounting	1.2 TDI		<b>F8-8173</b>		
Engine Mounting	1.2, 1.2 TDI, 1.4 TDI, 1.6, 1.6 TDI, 1.9 TDI, 2.0, 2.0 TDI		<b>F8-8173</b>		
Engine Mounting	1.4	BXW	<b>F8-8173</b>		
Engine Mounting	1.4	BXW;  7-speed	<b>F8-8173</b>		
Engine Mounting	1.4 TSI	CAVF	<b>F8-8173</b>		
Engine Mounting	1.6 TDI	ch.6J-B-000001→;	<b>F8-8173</b>		
Engine Mounting	1.6 TDI	ch.6J-B-000001→;  CAYC;	<b>F8-8173</b>		
Engine Mounting	1.6 TDI	CAYC	<b>F8-8173</b>		
Engine Mounting	1.6, 2.0 TDI	7-speed	<b>F8-8173</b>		

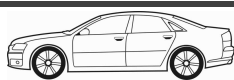

**Article Description****Article Nr.****Fitting Position**

<b>IBIZA V SPORTCOUPE (6J1, 6P5)</b>			<b>07/2008 → 06/2010</b>		
Dust Cover Kit, shock absorber	1.2, 1.2 TDI, 1.2 TSI, 1.4, 1.4 TDI, 1.4 TSI, 1.4 TSI Cupra, 1.6, 1.6 LPG, 1.6 TDI, 1.9 TDI, 2.0, 2.0 TDI	<b>ST</b>	<b>AK-735410</b>		H=210
Alternator Freewheel Clutch	1.2 TDI, 1.2 TSI, 1.4 TDI, 1.4 TSI, 1.4 TSI Cupra, 1.6 TDI, 1.9 TDI, 2.0, 2.0 TDI		<b>F5-1004</b>		
Alternator Freewheel Clutch	1.2 TSI, 1.4 TSI, 1.4 TSI Cupra, 1.6 LPG		<b>F5-1064</b>		
Alternator Freewheel Clutch	1.2, 1.4 TDI, 1.9 TDI		<b>F5-1085</b>		
Anti-Friction Bearing	1.2, 1.2 TDI, 1.2 TSI, 1.4, 1.4 TDI, 1.4 TSI, 1.4 TSI Cupra, 1.6, 1.6 LPG, 1.6 TDI, 1.9 TDI, 2.0, 2.0 TDI		<b>F8-3039</b>		H=14; d1=14; D=45
Top Strut Mounting	1.2, 1.4, 1.6, 1.9 TDI		<b>F8-4067</b>		H=53; d=26; D=82
Top Strut Mounting	1.2, 1.2 TDI, 1.2 TSI, 1.4, 1.4 TDI, 1.4 TSI, 1.4 TSI Cupra, 1.6, 1.6 TDI, 1.9 TDI, 2.0, 2.0 TDI		<b>F8-5380</b>		
Rubber Buffer, suspension	1.2, 1.2 TDI, 1.2 TSI, 1.4, 1.4 TDI, 1.4 TSI, 1.4 TSI Cupra, 1.6, 1.6 LPG, 1.6 TDI, 1.9 TDI, 2.0, 2.0 TDI		<b>F8-5381</b>		H=37; D=76
Engine Mounting	1.4		<b>F8-5534</b>		
Engine Mounting	1.6		<b>F8-5534</b>		
Protective Cap/Bellow, shock absorber	1.2, 1.2 TDI, 1.2 TSI, 1.4, 1.4 TDI, 1.4 TSI, 1.4 TSI Cupra, 1.6, 1.6 LPG, 1.6 TDI, 1.9 TDI, 2.0, 2.0 TDI		<b>F8-5683</b>		H=210
Rubber Buffer, suspension	1.2, 1.2 TDI, 1.2 TSI, 1.4, 1.4 TDI, 1.4 TSI, 1.4 TSI Cupra, 1.6, 1.6 LPG, 1.6 TDI, 1.9 TDI, 2.0, 2.0 TDI	for OE: G18, G20	<b>F8-5996</b>		H=63
Top Strut Mounting	1.2, 1.4, 1.4 TDI, 1.6, 1.9 TDI, 2.0	<b>SP</b>	<b>F8-6040</b>		
Rubber Buffer, suspension	1.2, 1.2 TDI, 1.2 TSI, 1.4, 1.4 TDI, 1.4 TSI Cupra, 1.6, 1.6 LPG, 1.6 TDI, 2.0, 2.0 TDI	for OE: G17, G19, G21, G24	<b>F8-6041</b>		H=53
Rubber Buffer, suspension	1.2, 1.4, 1.4 TDI, 1.6 TDI, 1.9 TDI	for OE: G17, G19	<b>F8-6041</b>		H=53
Protective Cap/Bellow, shock absorber	1.2, 1.2 TDI, 1.2 TSI, 1.4, 1.4 TDI, 1.4 TSI, 1.4 TSI Cupra, 1.6, 1.6 LPG, 1.6 TDI, 1.9 TDI, 2.0, 2.0 TDI	for OE: UB9; <b>SP</b>	<b>F8-6044</b>		H=160
Top Strut Mounting	1.2, 1.4, 1.6, 1.9 TDI		<b>F8-6280</b>		H=53; d=26; D=82
Belt Pulley, crankshaft	1.9 TDI	Number of Ribs: 5; Parameter: 6PK	<b>F8-6396</b>		H=41.6; d=30; Mounting points diam.[mm]=7, 8.6; D=139.7
Stabiliser Mounting	1.9 TDI	ch.6L-3-164394→	<b>F8-6462</b>		d=16
Control Arm-Trailing Arm Bush	1.2, 1.2 TDI, 1.4, 1.4 TDI, 1.4 TSI, 1.4 TSI Cupra, 1.6, 1.6 TDI, 1.9 TDI, 2.0, 2.0 TDI		<b>F8-6464</b>		H=41; d=13.5; W=60
Belt Pulley, crankshaft	1.2 TDI, 1.6 TDI, 2.0 TDI	Number of Ribs: 5; Parameter: 6PK	<b>F8-6572</b>		
Belt Pulley, crankshaft	1.6 TDI		<b>F8-6572</b>		
Top Strut Mounting	1.2, 1.2 TDI, 1.2 TSI, 1.4, 1.4 TDI, 1.4 TSI, 1.4 TSI Cupra, 1.6, 1.6 LPG, 1.6 TDI, 1.9 TDI, 2.0, 2.0 TDI	for OE: 1J0412319C	<b>F8-7133</b>		
Rubber Buffer, suspension	1.2, 1.4, 1.4 TDI, 1.4 TSI, 1.4 TSI Cupra, 1.6, 1.6 TDI, 1.9 TDI, 2.0, 2.0 TDI	for OE: 1JC, 1JS; <b>SP</b>	<b>F8-7658</b>		H=114
Mounting, axle beam	1.2, 1.2 TDI, 1.2 TSI, 1.4, 1.4 TDI, 1.4 TSI, 1.4 TSI Cupra, 1.6, 1.6 TDI, 1.9 TDI, 2.0, 2.0 TDI	for OE: 0N7; <b>HD</b>	<b>F8-7928</b>		
Engine Mounting	1.4		<b>F8-7949</b>		
Engine Mounting	1.6		<b>F8-7949</b>		

<b>AK-735410</b>	<b>F5-1004</b>	<b>F5-1064</b>	<b>F5-1085</b>	<b>F8-3039</b>	<b>F8-4067</b>	<b>F8-5380</b>
Ref.Nr.: 1J0412303	Ref.Nr.: 038903119T	Ref.Nr.: 03C903119D	Ref.Nr.: 045903119A	Ref.Nr.: 357412249A	Ref.Nr.: 1J0412331B	Ref.Nr.: 1J0513353G
<b>F8-5381</b>	<b>F8-5534</b>	<b>F8-5683</b>	<b>F8-5996</b>	<b>F8-6040</b>	<b>F8-6041</b>	<b>F8-6044</b>
Ref.Nr.: 1J0512149B	Ref.Nr.: 6Q0199851AB	Ref.Nr.: 357413175A	Ref.Nr.: 1H0412303B	Ref.Nr.: 1J0513353D	Ref.Nr.: 1J0412303	Ref.Nr.: 3C0513425
<b>F8-6280</b>	<b>F8-6396</b>	<b>F8-6462</b>	<b>F8-6464</b>	<b>F8-6572</b>	<b>F8-7133</b>	<b>F8-7658</b>
Ref.Nr.: 6R0412249	Ref.Nr.: 03G105243	Ref.Nr.: 6Q0411314L	Ref.Nr.: 8N0407181B	Ref.Nr.: 038105243L	Ref.Nr.: 1J0412319C	Ref.Nr.: 6Q0512131C

Article Description

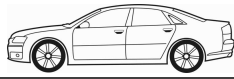

Article Nr.

Fitting Position



**IBIZA V SPORTCOUPE (6J1, 6P5)**

07/2008 → 06/2010

Engine Mounting	1.2	BZG;	F8-7951		
Engine Mounting	1.2	CGPA;	F8-7951		
Engine Mounting	1.2, 1.2 TSI, 1.4		F8-7951		
Engine Mounting	1.2		F8-7955		
Engine Mounting	1.9 TDI		F8-7956		
Belt Pulley, crankshaft	1.4 TDI	Number of Ribs: 5; Parameter: 6PK	F8-8038		
Engine Mounting	1.4 TDI, 1.6, 1.6 LPG, 2.0		F8-8164		
Engine Mounting	1.2	BZG	F8-8173		
Engine Mounting	1.2	CGPA	F8-8173		
Engine Mounting	1.2, 1.4, 1.4 TDI, 1.6, 1.6 TDI, 1.9 TDI, 2.0, 2.0 TDI		F8-8173		
Engine Mounting	1.4 TSI	CAVF	F8-8173		
Engine Mounting	1.4 TSI Cupra	CAVE	F8-8173		
Engine Mounting	1.4, 1.6, 2.0 TDI	7-speed	F8-8173		
Engine Mounting	1.6 TDI	ch.6J-B-000001→;	F8-8173		
Engine Mounting	1.6 TDI	ch.6J-B-000001→;  CGPA;  CAYC;	F8-8173		
Engine Mounting	1.6 TDI	CAYC	F8-8173		

**IBIZA V ST (6J8, 6P8)**

03/2010 →

Dust Cover Kit, shock absorber	1.2, 1.2 TDI, 1.2 TSI, 1.4, 1.6 TDI		AK-735410		H=210
Alternator Freewheel Clutch	1.2 TDI, 1.2 TSI, 1.4 TSI, 1.6 TDI		F5-1004		
Alternator Freewheel Clutch	1.2 TSI, 1.4 TSI, 1.6		F5-1064		
Anti-Friction Bearing	1.2, 1.2 TDI, 1.2 TSI, 1.4, 1.4 TSI, 1.6, 1.6 TDI		F8-3039		H=14; d1=14; D=45
Top Strut Mounting	1.2, 1.2 TDI, 1.2 TSI, 1.4, 1.6 TDI		F8-5380		
Rubber Buffer, suspension	1.2, 1.2 TDI, 1.2 TSI, 1.4, 1.4 TSI, 1.6, 1.6 TDI		F8-5381		H=37; D=76
Protective Cap/Bellow, shock absorber	1.2, 1.2 TDI, 1.2 TSI, 1.4, 1.6 TDI		F8-5683		H=210
Rubber Buffer, suspension	1.2, 1.2 TDI, 1.2 TSI, 1.4, 1.6 TDI	for OE: G18, G20	F8-5996		H=63
Rubber Buffer, suspension	1.2, 1.2 TDI, 1.2 TSI, 1.4, 1.4 TSI, 1.6, 1.6 TDI	for OE: G17, G19, G21, G24	F8-6041		H=53
Rubber Buffer, suspension	1.6 TDI	for OE: G17, G19	F8-6041		H=53
Protective Cap/Bellow, shock absorber	1.2, 1.2 TDI, 1.2 TSI, 1.4, 1.4 TSI, 1.6, 1.6 TDI	for OE: UB9;	F8-6044		H=160
Control Arm-/Trailing Arm Bush	1.2, 1.2 TDI, 1.4, 1.6 TDI		F8-6464		H=41; d=13,5; W=60
Belt Pulley, crankshaft	1.2 TDI, 1.6 TDI	Number of Ribs: 5; Parameter: 6PK	F8-6572		
Top Strut Mounting	1.2, 1.2 TDI, 1.2 TSI, 1.4, 1.4 TSI, 1.6, 1.6 TDI	for OE: 1J0412319C	F8-7133		
Rubber Buffer, suspension	1.2, 1.2 TDI, 1.2 TSI, 1.4, 1.6 TDI	for OE: 1JC, 1JS;	F8-7658		H=114
Mounting, axle beam	1.2, 1.2 TDI, 1.2 TSI, 1.4, 1.6 TDI	for OE: 0N7;	F8-7928		

<b>AK-735410</b>	<b>F5-1004</b>	<b>F5-1064</b>	<b>F8-3039</b>	<b>F8-5380</b>	<b>F8-5381</b>	<b>F8-5683</b>
Ref.Nr.: 1J0412303	Ref.Nr.: 038903119T	Ref.Nr.: 03C903119D	Ref.Nr.: 357412249A	Ref.Nr.: 1J0513353G	Ref.Nr.: 1J0512149B	Ref.Nr.: 357413175A
<b>F8-5996</b>	<b>F8-6041</b>	<b>F8-6044</b>	<b>F8-6464</b>	<b>F8-6572</b>	<b>F8-7133</b>	<b>F8-7658</b>
Ref.Nr.: 1H0412303B	Ref.Nr.: 1J0412303	Ref.Nr.: 3C0513425	Ref.Nr.: 8N0407181B	Ref.Nr.: 038105243L	Ref.Nr.: 1J0412319C	Ref.Nr.: 6Q0512131C
<b>F8-7928</b>	<b>F8-7951</b>	<b>F8-7955</b>	<b>F8-7956</b>	<b>F8-8038</b>	<b>F8-8164</b>	<b>F8-8173</b>
Ref.Nr.: 6Q0501541E	Ref.Nr.: 6Q0199555AR	Ref.Nr.: 6Q0199851AJ	Ref.Nr.: 6Q0199851AP	Ref.Nr.: 045105243C	Ref.Nr.: 6Q0199555AS	Ref.Nr.: 6Q0199555AT

**Article Description****Article Nr.****Fitting Position**

<b>IBIZA V ST (6J8, 6P8)</b>				<b>03/2010 →</b>	
Engine Mounting	1.2	CGPA;	<b>F8-7951</b>		
Engine Mounting	1.2, 1.2 TSI, 1.4		<b>F8-7951</b>		
Engine Mounting	1.2	CGPA	<b>F8-8173</b>		
Engine Mounting	1.2 TDI, 1.6 TDI	ch.6J-B-000001 →;	<b>F8-8173</b>		
Engine Mounting	1.2, 1.2 TDI, 1.2 TSI, 1.4, 1.6 TDI		<b>F8-8173</b>		
Engine Mounting	1.4	7-speed	<b>F8-8173</b>		
<b>INCA (6K9)</b>				<b>11/1995 → 06/2003</b>	
Dust Cover Kit, shock absorber	1.7 D, 1.9 D, 1.9 SDI, 1.9 TDI		<b>AK-733023</b>		
Alternator Freewheel Clutch	1.7 D, 1.9 D, 1.9 SDI		<b>F5-1007</b>		
Control Arm-/Trailing Arm Bush	1.4 i, 1.6 i, 1.7 D, 1.9 D, 1.9 SDI	without guide sleeve	<b>F8-1007</b>		H1=26; H2=41; d=17; D1=60; D2=68
Control Arm-/Trailing Arm Bush	1.4 i, 1.6 i, 1.7 D, 1.9 D, 1.9 SDI	with guide sleeve	<b>F8-1007S</b>		H1=26; H2=41; d=17; D1=60; D2=68
Repair Kit, link	1.4 16V, 1.4 i, 1.6 i, 1.7 D, 1.9 D, 1.9 SDI, 1.9 TDI	with guide sleeve	<b>F8-1008</b>		H1=24; H2=41; d=17; D=60
Engine Mounting	1.6 i		<b>F8-1011</b>		H=133; D1=80; D2=108
Engine Mounting	1.6 i, 1.7 D, 1.9 D, 1.9 SDI		<b>F8-1015</b>		H=82; D1=55; D2=71
Top Strut Mounting	1.4 i, 1.6 i, 1.7 D, 1.9 D, 1.9 SDI		<b>F8-1034</b>		H=50; d=27; D=98
Top Strut Mounting	1.4 i, 1.6 i, 1.7 D, 1.9 D, 1.9 SDI		<b>F8-1034S</b>		H=51; d=14; D=96
Anti-Friction Bearing	All Models		<b>F8-3039</b>		H=14; d1=14; D=45
Stabiliser Mounting	1.4 i, 1.6 i, 1.7 D, 1.9 D, 1.9 SDI	ch.→9K-V-012500	<b>F8-3042</b>		H=33; d=17; W=35
Stabiliser Mounting	1.6 i		<b>F8-3042</b>		H=33; d=17; W=35
Flange, carburettor	1.6 i		<b>F8-3048</b>		H=27; d=40
Engine Mounting	1.7 D, 1.9 D, 1.9 SDI		<b>F8-3053</b>		H=135; D1=79; D2=93
Engine Mounting	1.7 D, 1.9 D, 1.9 SDI		<b>F8-4016</b>		
Engine Mounting	1.4 i, 1.6 i		<b>F8-4017</b>		
Bellow, steering	1.9 SDI		<b>F8-4075</b>		H=200; d=10; D=48
Stabiliser Mounting	All Models	ch.6K-V-012501→	<b>F8-5395</b>		d=19
Engine Mounting	1.6 i		<b>F8-5397</b>		
Engine Mounting	1.4 i	AEX, AKV, APQ	<b>F8-5398</b>		
Engine Mounting	1.6 i		<b>F8-5398</b>		
Engine Mounting	1.6 i	AEE	<b>F8-5398</b>		
Engine Mounting	1.4 i, 1.6 i		<b>F8-5554</b>		H=39.5; d1=16; d2=24; D=50
Belt Pulley, crankshaft	1.7 D, 1.9 D, 1.9 SDI	Number of Ribs: 5; Parameter: 6PK	<b>F8-5649</b>		H=31.5; d=30.02; Mounting points diam.[mm]=8.5; D1=161.5; D2=160.5
Holder, engine mounting	1.7 D, 1.9 D, 1.9 SDI		<b>F8-5672</b>		H=39.5; D=24

<b>AK-733023</b>	<b>F5-1007</b>	<b>F8-1007</b>	<b>F8-1007S</b>	<b>F8-1008</b>	<b>F8-1011</b>	<b>F8-1015</b>
Ref.Nr.: 191412303	Ref.Nr.: 028903119AQ	Ref.Nr.: 191407181A	Ref.Nr.: 191407181A	Ref.Nr.: 191407181E	Ref.Nr.: 1H0199262F	Ref.Nr.: 357199402
<b>F8-1034</b>	<b>F8-1034S</b>	<b>F8-3039</b>	<b>F8-3042</b>	<b>F8-3048</b>	<b>F8-3053</b>	<b>F8-4016</b>
Ref.Nr.: 357412331A	Ref.Nr.: 7201848S1	Ref.Nr.: 357412249A	Ref.Nr.: 191411314	Ref.Nr.: 050129761B	Ref.Nr.: 1H0199609B	Ref.Nr.: 1H0199262G
<b>F8-4017</b>	<b>F8-4075</b>	<b>F8-5395</b>	<b>F8-5397</b>	<b>F8-5398</b>	<b>F8-5554</b>	<b>F8-5649</b>
Ref.Nr.: 1H0199262E	Ref.Nr.: 357422831	Ref.Nr.: 1H0411314	Ref.Nr.: 1H0199609F	Ref.Nr.: 1H0199609E	Ref.Nr.: 191199233	Ref.Nr.: 028105243T

Article Description



Article Nr.

Fitting Position



<b>INCA (6K9)</b>			<b>11/1995 → 06/2003</b>		
Belt Pulley, crankshaft	1.9 SDI	AYQ; Engine074038→; Number of Ribs: 5; Parameter: 6PK	<b>F8-6396</b>		H=41.6; d=30; Mounting points diam.[mm]=7, 8.6; D=139.7
Belt Pulley, crankshaft	1.9 TDI	Engine896340→; Number of Ribs: 5; Parameter: 6PK	<b>F8-6396</b>		H=41.6; d=30; Mounting points diam.[mm]=7, 8.6; D=139.7
Sleeve, control arm mounting	All Models		<b>F8-6699</b>	⊕ ⊕	d=16; L=50; D=17
Engine Mounting	1.4 i		<b>F8-6922</b>	⊕	H=65
Engine Mounting	1.9 SDI	AYQ	<b>F8-6922</b>	⊕	H=65
Bellow, driveshaft	1.4 i	AEX	<b>F8-7722</b>	⊕ ⊕ ⊕	d1=26; d2=78; L=110
Bellow, driveshaft	1.6 i	AEE	<b>F8-7722</b>	⊕ ⊕ ⊕	d1=26; d2=78; L=110
Bellow, driveshaft	1.6 i	FER	<b>F8-7722</b>	⊕ ⊕ ⊕	d1=26; d2=78; L=110
Bellow, driveshaft	1.7 D, 1.9 D		<b>F8-7722</b>	⊕ ⊕ ⊕	d1=26; d2=78; L=110
Bellow, driveshaft	1.9 SDI	AEY	<b>F8-7722</b>	⊕ ⊕ ⊕	d1=26; d2=78; L=110
Belt Pulley, crankshaft	1.9 SDI	AYQ; Engine →074037	<b>F8-7864</b>		
Belt Pulley, crankshaft	1.9 TDI	Engine →896339	<b>F8-7864</b>		
Control Arm-/Trailing Arm Bush	All Models		<b>F8-7978</b>	⊕ ⊕	
Control Arm-/Trailing Arm Bush	1.4 16V, 1.4 i, 1.6 i, 1.7 D, 1.9 D, 1.9 SDI, 1.9 TDI		<b>G9-648</b>	⊕ ⊕ ⊕ ↓	H=54; d=12; D1=33; D2=36
Bellow, steering	All Models	with clamps; ⊕	<b>LM-10003S</b>		d1=9; d2=43; L [mm]=210
Bellow, steering	All Models	with clamps; ⊕	<b>LM-10006S</b>		d1=10; d2=41; L [mm]=210
Bellow, driveshaft	1.4 i, 1.6 i, 1.7 D, 1.9 D, 1.9 SDI		<b>M-830220</b>	⊕ ⊕ ⊕	
Bellow Set, drive shaft	1.4 i	AEX	<b>MK-830220</b>		
Bellow Set, drive shaft	1.6 i	AEE	<b>MK-830220</b>		
Bellow Set, drive shaft	1.7 D, 1.9 D		<b>MK-830220</b>		
Bellow Set, drive shaft	1.9 SDI	AEY	<b>MK-830220</b>		
Bellow Set, drive shaft	1.7 D, 1.9 D		<b>MK-830220S</b>		
<b>LEON (1M1)</b>			<b>11/1999 → 06/2006</b>		
Dust Cover Kit, shock absorber	1.4 16V, 1.6, 1.6 16 V, 1.8 20V, 1.8 20V T 4, 1.8 T Cupra R, 1.9 SDI, 1.9 TDI, 1.9 TDI Syncro, 2.8 Cupra 4		<b>AK-735039</b>	⊕ ⊕ ⊕	
Dust Cover Kit, shock absorber	1.4 16V, 1.6, 1.6 16 V, 1.8 20V, 1.8 20V T, 1.9 SDI, 1.9 TDI		<b>AK-735095</b>	⊕ ⊕	
Dust Cover Kit, shock absorber	All Models	<b>ST</b>	<b>AK-735410</b>	⊕ ⊕ ⊕	H=210
Alternator Freewheel Clutch	1.6, 1.8 20V, 1.8 20V T, 1.8 20V T 4, 1.8 T Cupra R, 1.9 SDI, 1.9 TDI, 1.9 TDI Syncro, 2.8, 2.8 Cupra 4		<b>F5-1004</b>		
Anti-Friction Bearing	All Models		<b>F8-3039</b>	⊕ ⊕ ⊕	H=14; d1=14; D=45

<b>AK-735039</b>	<b>AK-735095</b>	<b>AK-735410</b>	<b>F5-1004</b>	<b>F8-3039</b>	<b>F8-4067</b>	<b>F8-6396</b>
Ref.Nr.: 357413175A	Ref.Nr.: 1J0512131B	Ref.Nr.: 1J0412303	Ref.Nr.: 038903119T	Ref.Nr.: 357412249A	Ref.Nr.: 1J0412331B	Ref.Nr.: 03G105243
<b>F8-6699</b>	<b>F8-6922</b>	<b>F8-7722</b>	<b>F8-7864</b>	<b>F8-7978</b>	<b>G9-648</b>	<b>LM-10003S</b>
Ref.Nr.: 191407190A	Ref.Nr.: 191199381A	Ref.Nr.: 191407285F	Ref.Nr.: 038 105 243	Ref.Nr.: 357407182F	Ref.Nr.: 357407182	Ref.Nr.: 357422831A
<b>LM-10006S</b>	<b>M-830220</b>	<b>MK-830220</b>				
Ref.Nr.: 1H0422831B	Ref.Nr.: 191498203C	Ref.Nr.: 171498203	Ref.Nr.:			



**Article Description****Article Nr.****Fitting Position**

<b>LEON (1M1)</b>		<b>11/1999 → 06/2006</b>	
Top Strut Mounting	1.4 16V, 1.6, 1.6 16 V, 1.8 20V, 1.8 20V T 4, 1.8 T Cupra R, 1.9 SDI, 1.9 TDI, 1.9 TDI Syncro, 2.8 Cupra 4		<b>F8-4067</b>
Stabiliser Mounting	1.4 16V, 1.6, 1.6 16 V, 1.8 20V, 1.8 20V T 4, 1.9 SDI, 1.9 TDI, 2.8 Cupra 4	only in connection with: F8-6579; Stabi. Diam. [mm]= 23	<b>F8-5220</b>
Stabiliser Mounting	1.4 16V, 1.6, 1.6 16 V, 1.8 20V, 1.8 20V T 4, 1.9 SDI, 1.9 TDI, 2.8 Cupra 4	only in connection with: F8-6579; Stabi. Diam. [mm]= 21	<b>F8-5221</b>
Top Strut Mounting	1.4 16V, 1.6, 1.6 16 V, 1.8 20V, 1.8 20V T, 1.8 T Cupra R, 1.9 SDI, 1.9 TDI	not for equipment variant: 1JC, UB5	<b>F8-5380</b>
Top Strut Mounting	1.8 20V T 4, 1.9 TDI Syncro, 2.8 Cupra 4		<b>F8-5380</b>
Rubber Buffer, suspension	1.4 16V, 1.6, 1.6 16 V, 1.8 20V, 1.8 20V T, 1.8 T Cupra R, 1.9 SDI, 1.9 TDI		<b>F8-5381</b>
Engine Mounting	1.9 SDI		<b>F8-5384</b>
Engine Mounting	1.6, 1.8 20V, 1.9 TDI		<b>F8-5386</b>
Mounting, automatic transmission	1.8 20V, 1.9 TDI		<b>F8-5387</b>
Engine Mounting	1.4 16V, 1.6 16 V		<b>F8-5388</b>
Engine Mounting	1.6		<b>F8-5390</b>
Spring Cap	All Models		<b>F8-5580</b>
Belt Pulley, crankshaft	1.8 20V, 1.8 20V T, 1.8 20V T 4		<b>F8-5650</b>
Protective Cap/Bellow, shock absorber	All Models		<b>F8-5683</b>
Mounting, axle beam	1.4 16V, 1.6, 1.6 16 V, 1.8 20V, 1.8 20V T 4, 1.9 SDI, 1.9 TDI, 1.9 TDI Syncro, 2.8, 2.8 Cupra 4		<b>F8-5907</b>
Rubber Buffer, suspension	1.4 16V, 1.6, 1.6 16 V, 1.8 20V, 1.8 20V T 4, 1.9 SDI, 1.9 TDI	for OE: 1GB, G10;	<b>F8-5993</b>
Rubber Buffer, suspension	1.6, 1.9 TDI, 1.9 TDI Syncro, 2.8	for OE: G10;	<b>F8-5993</b>
Rubber Buffer, suspension	1.4 16V, 1.6, 1.6 16 V, 1.8 20V, 1.8 20V T, 1.9 SDI, 1.9 TDI	ch.→1M-1-035000; for OE: 1GA, 1GD, 1GG, G22, G23, G24;	<b>F8-5996</b>
Rubber Buffer, suspension	1.4 16V, 1.6, 1.6 16 V, 1.8 20V, 1.8 20V T, 1.9 SDI, 1.9 TDI	ch.1M-1-035001→; for OE: G22, G23, G24;	<b>F8-5996</b>
Rubber Buffer, suspension	1.4 16V, 1.6, 1.6 16 V, 1.8 20V, 1.8 20V T, 1.9 SDI, 1.9 TDI	ch.1M-1-035001→; for OE: G25;	<b>F8-5996</b>
Rubber Buffer, suspension	1.4 16V, 1.6, 1.6 16 V, 1.8 20V, 1.8 20V T, 1.9 SDI, 1.9 TDI	ch.1M-1-035001→; for OE: G52;	<b>F8-5996</b>
Rubber Buffer, suspension	1.6, 1.9 TDI	for OE: G22, G23, G24;	<b>F8-5996</b>
Rubber Buffer, suspension	1.6, 1.9 TDI	for OE: G25;	<b>F8-5996</b>
Rubber Buffer, suspension	1.6, 1.9 TDI	for OE: G52;	<b>F8-5996</b>
Rubber Buffer, suspension	1.4 16V, 1.6, 1.6 16 V, 1.8 20V, 1.8 20V T 4, 1.8 T Cupra R, 1.9 SDI, 1.9 TDI, 1.9 TDI Syncro, 2.8 Cupra 4		<b>F8-6012</b>

<b>F8-4067</b>	<b>F8-5220</b>	<b>F8-5221</b>	<b>F8-5380</b>	<b>F8-5381</b>	<b>F8-5384</b>	<b>F8-5386</b>
Ref.Nr.: 1J0412331B	Ref.Nr.: 1J0411314G	Ref.Nr.: 1J0411314R	Ref.Nr.: 1J0513353G	Ref.Nr.: 1J0512149B	Ref.Nr.: 1J0199555AL	Ref.Nr.: 1J0199555AJ
<b>F8-5387</b>	<b>F8-5388</b>	<b>F8-5390</b>	<b>F8-5580</b>	<b>F8-5650</b>	<b>F8-5683</b>	<b>F8-5907</b>
Ref.Nr.: 1J0199555AH	Ref.Nr.: 1J0199262BK	Ref.Nr.: 1J0199262BE	Ref.Nr.: 1J0412341	Ref.Nr.: 06A105243E	Ref.Nr.: 357413175A	Ref.Nr.: 1J0199429
<b>F8-5993</b>	<b>F8-5996</b>	<b>F8-6012</b>	<b>F8-6040</b>			
Ref.Nr.: 357412303F	Ref.Nr.: 1H0412303B	Ref.Nr.: 1J0512131	Ref.Nr.: 1J0513353D			

Article Description



Article Nr.

Fitting Position



## LEON (1M1)

11/1999 → 06/2006

Top Strut Mounting	1.4 16V, 1.6, 1.6 16 V, 1.8 20V, 1.8 20V T, 1.8 T Cupra R, 1.9 SDI, 1.9 TDI	for OE: 1JC, UB5	<b>F8-6040</b>		
Rubber Buffer, suspension	1.4 16V, 1.6, 1.6 16 V, 1.8 20V, 1.8 20V T, 1.9 SDI, 1.9 TDI	ch.1M-1-035001→; for OE: G26, G61, G62, G63, G64, G99; <b>SP</b>	<b>F8-6041</b>		H=53
Rubber Buffer, suspension	1.4 16V, 1.6, 1.9 SDI	ch.→1M-1-035000; for OE: 1GD; <b>SP</b>	<b>F8-6041</b>		H=53
Rubber Buffer, suspension	1.6 16 V, 1.8 20V, 1.8 20V T, 1.9 TDI	ch.→1M-1-035000; for OE: 1GL, G25, G26, G99; <b>SP</b>	<b>F8-6041</b>		H=53
Rubber Buffer, suspension	1.6, 1.9 TDI, 2.8	for OE: G26, G61, G62, G63, G64, G99; <b>SP</b>	<b>F8-6041</b>		H=53
Rubber Buffer, suspension	1.8 20V T 4, 1.9 TDI Syncro, 2.8 Cupra 4	for OE: G96	<b>F8-6041</b>		H=53
Protective Cap/Bellow, shock absorber	1.4 16V, 1.6, 1.6 16 V, 1.8 20V, 1.8 20V T, 1.8 T Cupra R, 1.9 SDI, 1.9 TDI, 2.8	for OE: 1JB; <b>Δ</b>	<b>F8-6044</b>		H=160
Protective Cap/Bellow, shock absorber	1.4 16V, 1.6, 1.6 16 V, 1.8 20V, 1.8 20V T, 1.8 T Cupra R, 1.9 SDI, 1.9 TDI, 2.8	for OE: 1JD; <b>ST</b>	<b>F8-6044</b>		H=160
Mounting, axle beam	1.4 16V, 1.6, 1.6 16 V, 1.8 20V, 1.8 20V T, 1.8 T Cupra R, 1.9 SDI, 1.9 TDI, 2.8		<b>F8-6076</b>		d=12; L=90; D=69
Repair Set, axle beam	1.4 16V, 1.6, 1.6 16 V, 1.8 20V, 1.8 20V T, 1.8 T Cupra R, 1.9 SDI, 1.9 TDI, 2.8		<b>F8-6077</b>		H=90; D=69
Top Strut Mounting	1.4 16V, 1.6, 1.6 16 V, 1.8 20V, 1.8 20V T, 1.8 20V T 4, 1.8 T Cupra R, 1.9 SDI, 1.9 TDI, 1.9 TDI Syncro, 2.8 Cupra 4	not for equipment variant: G92; <b>⊗</b>	<b>F8-6280</b>		H=53; d=26; D=82
Belt Pulley, crankshaft	1.9 TDI	01/2002 →; Number of Ribs: 5; Parameter: 6PK	<b>F8-6392</b>		H=47; d=30; D=143
Belt Pulley, crankshaft	1.9 TDI	Engine →435000; Number of Ribs: 5; Parameter: 6PK	<b>F8-6392</b>		H=47; d=30; D=143
Belt Pulley, crankshaft	1.9 TDI Syncro	Number of Ribs: 5; Parameter: 6PK	<b>F8-6392</b>		H=47; d=30; D=143
Belt Pulley, crankshaft	1.9 SDI, 1.9 TDI	ch.1M-3R099131→; Number of Ribs: 5; Parameter: 6PK	<b>F8-6396</b>		H=41.6; d=30; Mounting points diam.[mm]=7, 8.6; D=139.7
Belt Pulley, crankshaft	1.9 TDI	Engine435001→; Number of Ribs: 5; Parameter: 6PK	<b>F8-6396</b>		H=41.6; d=30; Mounting points diam.[mm]=7, 8.6; D=139.7
Control Arm-/Trailing Arm Bush	1.8 T Cupra R		<b>F8-6464</b>		H=41; d=13.5; W=60
Bracket, stabilizer mounting	All Models		<b>F8-6579</b>		
Engine Mounting	1.9 TDI		<b>F8-6960</b>		
Mounting, axle bracket	1.8 20V T 4, 1.9 TDI Syncro, 2.8 Cupra 4		<b>F8-7046</b>		H=55; d=16; D=52
Top Strut Mounting	All Models	for OE: 1J0412319C	<b>F8-7133</b>		
Belt Pulley, crankshaft	1.9 SDI, 1.9 TDI	ch.→1M-3R099130	<b>F8-7864</b>		
Stabiliser Mounting	1.8 20V T, 1.8 20V T 4, 1.9 TDI Syncro, 2.8		<b>F8-7927</b>		d=18
Control Arm-/Trailing Arm Bush	1.4 16V, 1.6, 1.6 16 V, 1.8 20V, 1.8 20V T, 1.8 20V T 4, 1.8 T Cupra R, 1.9 SDI, 1.9 TDI, 2.8, 2.8 Cupra 4		<b>F8-7978</b>		
Control Arm-/Trailing Arm Bush	1.4 16V, 1.6, 1.6 16 V, 1.8 20V, 1.8 20V T, 1.8 20V T 4, 1.9 SDI, 1.9 TDI, 1.9 TDI Syncro, 2.8 Cupra 4		<b>G9-648</b>		H=54; d=12; D1=33; D2=36

<b>F8-6040</b>	<b>F8-6041</b>	<b>F8-6044</b>	<b>F8-6076</b>	<b>F8-6077</b>	<b>F8-6280</b>	<b>F8-6392</b>
Ref.Nr.: 1J0513353D	Ref.Nr.: 1J0412303	Ref.Nr.: 3C0513425	Ref.Nr.: 1J0501541D	Ref.Nr.: 1J0501541DS	Ref.Nr.: 6R0412249	Ref.Nr.: 038105243
<b>F8-6396</b>	<b>F8-6464</b>	<b>F8-6579</b>	<b>F8-6960</b>	<b>F8-7046</b>	<b>F8-7133</b>	<b>F8-7864</b>
Ref.Nr.: 03G105243	Ref.Nr.: 8N0407181B	Ref.Nr.: 1J0 411 336 C	Ref.Nr.: 1J0199262P	Ref.Nr.: 1J0505145B	Ref.Nr.: 1J0412319C	Ref.Nr.: 038 105 243
<b>F8-7927</b>	<b>F8-7978</b>	<b>G9-648</b>	<b>G9-649</b>			
Ref.Nr.: 1J0411314AC	Ref.Nr.: 357407182F	Ref.Nr.: 357407182	Ref.Nr.: 1J0407181			

**Article Description****Article Nr.****Fitting Position**

<b>LEON (1M1)</b>				<b>11/1999 → 06/2006</b>	
Control Arm-/Trailing Arm Bush	1.4 16V, 1.6, 1.6 16 V, 1.8 20V, 1.8 20V T, 1.8 20V T 4, 1.9 SDI, 1.9 TDI, 1.9 TDI Syncro, 2.8 Cupra 4		<b>G9-649</b>		H1=25; H2=41; d=13; D=60
Bellow, steering	1.4 16V, 1.6, 1.6 16 V, 1.8 20V, 1.8 20V T, 1.8 20V T 4, 1.8 T Cupra R, 1.9 SDI, 1.9 TDI, 1.9 TDI Syncro, 2.8, 2.8 Cupra 4	with clamps;	<b>LM-10020S</b>		d1=16; d2=48; L [mm]=179
<b>LEON (1P1)</b>				<b>05/2005 → 12/2012</b>	
Dust Cover Kit, shock absorber	1.6, 1.9 TDI, 2.0 FSI, 2.0 TDI, 2.0 TDI 16V, 2.0 TFSI		<b>AK-735039</b>		
Dust Cover Kit, shock absorber	1.6, 1.9 TDI, 2.0 FSI, 2.0 TDI, 2.0 TDI 16V, 2.0 TFSI		<b>AK-735264</b>		
Dust Cover Kit, shock absorber	1.6, 1.9 TDI, 2.0 FSI, 2.0 TDI, 2.0 TDI 16V, 2.0 TFSI		<b>AK-735265</b>		
Dust Cover Kit, shock absorber	1.2 TSI, 1.4 16V, 1.4 TSI, 1.6, 1.6 LPG, 1.6 TDI, 1.8 TSI, 1.9 TDI, 2.0 Cupra R, 2.0 FSI, 2.0 TDI, 2.0 TDI 16V, 2.0 TFSI	<b>ST</b>	<b>AK-735410</b>		H=210
Alternator Freewheel Clutch	1.4 TSI, 1.6, 1.6 LPG, 1.6 MultiFuel, 1.6 TDI, 1.8 TSI, 1.9 TDI, 2.0 Cupra R, 2.0 FSI, 2.0 TDI, 2.0 TDI 16V, 2.0 TFSI		<b>F5-1004</b>		
Alternator Freewheel Clutch	1.8 TSI, 2.0 TFSI		<b>F5-1044</b>		
Alternator Freewheel Clutch	1.2 TSI, 1.4 TSI		<b>F5-1064</b>		
Rubber Buffer, suspension	1.6, 1.9 TDI, 2.0 FSI, 2.0 TDI, 2.0 TDI 16V, 2.0 TFSI		<b>F8-5381</b>		H=37; D=76
Spring Cap	1.4 16V, 1.4 TSI, 1.6, 1.8 TSI, 1.9 TDI, 2.0 FSI, 2.0 TDI, 2.0 TDI 16V, 2.0 TFSI		<b>F8-5580</b>		D=92
Control Arm-/Trailing Arm Bush	All Models		<b>F8-5633</b>		
Belt Pulley, crankshaft	2.0 FSI		<b>F8-5650</b>		
Protective Cap/Bellow, shock absorber	1.2 TSI, 1.4 16V, 1.4 TSI, 1.6, 1.6 LPG, 1.6 TDI, 1.8 TSI, 1.9 TDI, 2.0 Cupra R, 2.0 FSI, 2.0 TDI, 2.0 TDI 16V, 2.0 TFSI		<b>F8-5683</b>		H=210
Mounting, axle beam	1.6, 1.9 TDI, 2.0 FSI, 2.0 TDI, 2.0 TDI 16V, 2.0 TFSI		<b>F8-6076</b>		d=12; L=90; D=69
Repair Set, axle beam	1.6	BSE	<b>F8-6077</b>		H=90; D=69
Repair Set, axle beam	1.9 TDI, 2.0 FSI, 2.0 TDI, 2.0 TDI 16V, 2.0 TFSI		<b>F8-6077</b>		H=90; D=69
Repair Set, axle beam	2.0 TDI	BMN	<b>F8-6077</b>		H=90; D=69
Top Strut Mounting	1.2 TSI, 1.4 16V, 1.4 TSI, 1.6, 1.6 LPG, 1.6 TDI, 1.8 TSI, 1.9 TDI, 2.0 Cupra R, 2.0 FSI, 2.0 TDI, 2.0 TDI 16V, 2.0 TFSI		<b>F8-6284</b>		
Top Strut Mounting	1.2 TSI, 1.4 16V, 1.4 TSI, 1.6, 1.6 LPG, 1.6 MultiFuel, 1.6 TDI, 1.8 TSI, 1.9 TDI, 2.0 Cupra R, 2.0 FSI, 2.0 TDI, 2.0 TDI 16V, 2.0 TFSI	for OE: 1JA, 1JC, UC5; <b>ST</b>	<b>F8-6348</b>		
Top Strut Mounting	1.2 TSI, 1.4 16V, 1.4 TSI, 1.6, 1.6 LPG, 1.6 MultiFuel, 1.6 TDI, 1.8 TSI, 1.9 TDI, 2.0 Cupra R, 2.0 FSI, 2.0 TDI, 2.0 TDI 16V, 2.0 TFSI	for OE: UC6; <b>SP</b>	<b>F8-6348</b>		
Top Strut Mounting	1.2 TSI, 1.4 16V, 1.4 TSI, 1.6, 1.6 LPG, 1.6 TDI, 1.8 TSI, 1.9 TDI, 2.0 Cupra R, 2.0 TDI, 2.0 TDI 16V, 2.0 TFSI	for OE: 1JE, 1JF; 2011→; <b>SP</b>	<b>F8-6348</b>		

<b>AK-735039</b>	<b>AK-735264</b>	<b>AK-735265</b>	<b>AK-735410</b>	<b>F5-1004</b>	<b>F5-1044</b>	<b>F5-1064</b>
Ref.Nr.: 357413175A	Ref.Nr.: 6N0413175A	Ref.Nr.: 1K0511353Q	Ref.Nr.: 1J0412303	Ref.Nr.: 038903119T	Ref.Nr.: 06B903119B	Ref.Nr.: 03C903119D
<b>F8-5381</b>	<b>F8-5580</b>	<b>F8-5633</b>	<b>F8-5650</b>	<b>F8-5683</b>	<b>F8-6076</b>	<b>F8-6077</b>
Ref.Nr.: 1J0512149B	Ref.Nr.: 1J0412341	Ref.Nr.: 1K0407182A	Ref.Nr.: 06A105243E	Ref.Nr.: 357413175A	Ref.Nr.: 1J0501541D	Ref.Nr.: 1J0501541DS
<b>F8-6284</b>	<b>F8-6348</b>	<b>G9-649</b>	<b>LM-10020S</b>			
Ref.Nr.: 6N0412249C	Ref.Nr.: 1K0513353G	Ref.Nr.: 1J0407181	Ref.Nr.: 1J0422831B			

Article Description



Article Nr.

Fitting Position



LEON (1P1)			05/2005 → 12/2012		
Top Strut Mounting	1.2 TSI, 1.4 16V, 1.4 TSI, 1.6, 1.6 LPG, 1.6 TDI, 1.8 TSI, 1.9 TDI, 2.0 Cupra R, 2.0 TDI, 2.0 TDI 16V, 2.0 TFSI	for OE: UC4; →2011; <b>SP</b>	<b>F8-6348</b>		
Top Strut Mounting	1.6 MultiFuel, 1.6 TDI	for OE: 1JE, 1JF; <b>SP</b>	<b>F8-6348</b>		
Top Strut Mounting	2.0 FSI, 2.0 TDI, 2.0 TFSI	for OE: UC4; <b>SP</b>	<b>F8-6348</b>		
Belt Pulley, crankshaft	1.9 TDI, 2.0 TDI, 2.0 TDI 16V	Number of Ribs: 5; Parameter: 6PK	<b>F8-6396</b>		H=41.6; d=30; Mounting points diam.[mm]=7, 8.6; D=139.7
Control Arm-/Trailing Arm Bush	1.4 16V, 1.4 TSI, 1.6, 1.6 LPG, 1.8 TSI, 1.9 TDI, 2.0 Cupra R, 2.0 FSI, 2.0 TDI, 2.0 TDI 16V, 2.0 TFSI	Aluminium	<b>F8-6424</b>		
Control Arm-/Trailing Arm Bush	1.4 16V, 1.4 TSI, 1.6, 1.6 LPG, 1.8 TSI, 1.9 TDI, 2.0 Cupra R, 2.0 FSI, 2.0 TDI, 2.0 TDI 16V, 2.0 TFSI	Aluminium	<b>F8-6425</b>		
Control Arm-/Trailing Arm Bush	1.4 16V, 1.4 TSI, 1.6, 1.8 TSI, 1.9 TDI, 2.0 FSI, 2.0 TDI, 2.0 TDI 16V, 2.0 TFSI		<b>F8-6463</b>		H=64; d=12; D=60
Engine Mounting	2.0 TDI	BMN	<b>F8-6528</b>		
Engine Mounting	2.0 TDI, 2.0 TDI 16V		<b>F8-6528</b>		
Engine Mounting	1.4 16V		<b>F8-6531</b>		H=117.7; L=165; W=149
Anti-Friction Bearing	1.2 TSI, 1.4 16V, 1.4 TSI, 1.6, 1.6 LPG, 1.6 MultiFuel, 1.6 TDI, 1.8 TSI, 1.9 TDI, 2.0 Cupra R, 2.0 FSI, 2.0 TDI, 2.0 TDI 16V, 2.0 TFSI		<b>F8-6569</b>		
Top Strut Mounting	1.2 TSI, 1.4 16V, 1.4 TSI, 1.6, 1.6 LPG, 1.6 TDI, 1.8 TSI, 1.9 TDI, 2.0 Cupra R, 2.0 FSI, 2.0 TDI, 2.0 TDI 16V, 2.0 TFSI	not for PR: G63;	<b>F8-6570</b>		
Belt Pulley, crankshaft	1.6 TDI	Number of Ribs: 5; Parameter: 6PK	<b>F8-6572</b>		
Belt Pulley, crankshaft	2.0 TDI	CFJA; Number of Ribs: 5; Parameter: 6PK	<b>F8-6572</b>		
Belt Pulley, crankshaft	2.0 TDI 16V	CFHC, CLCB; Number of Ribs: 5; Parameter: 6PK	<b>F8-6572</b>		
Bracket, stabilizer mounting	1.6	BSE, BSF	<b>F8-6579</b>		
Bracket, stabilizer mounting	1.9 TDI	BKC, BLS	<b>F8-6579</b>		
Bracket, stabilizer mounting	2.0 FSI, 2.0 TDI, 2.0 TFSI		<b>F8-6579</b>		
Bracket, stabilizer mounting	2.0 TDI 16V	BKD	<b>F8-6579</b>		
Engine Mounting	1.6		<b>F8-6988</b>		
Engine Mounting	1.8 TSI, 2.0 FSI, 2.0 TFSI		<b>F8-6989</b>		
Rubber Buffer, suspension	1.2 TSI, 1.4 16V, 1.4 TSI, 1.6, 1.6 LPG, 1.6 TDI, 1.8 TSI, 1.9 TDI, 2.0 Cupra R, 2.0 FSI, 2.0 TDI, 2.0 TDI 16V, 2.0 TFSI	for OE: G36, G40, G52, G53, G61, G62	<b>F8-7131</b>		H=70
Protective Cap/Bellow, shock absorber	1.2 TSI, 1.4 16V, 1.4 TSI, 1.6, 1.6 LPG, 1.6 TDI, 1.8 TSI, 1.9 TDI, 2.0 Cupra R, 2.0 FSI, 2.0 TDI, 2.0 TDI 16V, 2.0 TFSI		<b>F8-7132</b>		H=190
Rubber Buffer, suspension	All Models	for OE: 1JA, 1JC, 1JE; <b>SP</b> , <b>ST</b>	<b>F8-7580</b>		H=101
Rubber Buffer, suspension	All Models	for OE: UC4, UC5, UC6; Shape Round; <b>SP</b>	<b>F8-7601</b>		H=118

<b>F8-6348</b>	<b>F8-6396</b>	<b>F8-6424</b>	<b>F8-6425</b>	<b>F8-6463</b>	<b>F8-6528</b>	<b>F8-6531</b>
Ref.Nr.: 1K0513353G	Ref.Nr.: 03G105243	Ref.Nr.: 1K0199232G	Ref.Nr.: 1K0199231J	Ref.Nr.: 1K0505541B	Ref.Nr.: 1K0 199 262 AT	Ref.Nr.: 1K0199262T
<b>F8-6569</b>	<b>F8-6570</b>	<b>F8-6572</b>	<b>F8-6579</b>	<b>F8-6988</b>	<b>F8-6989</b>	<b>F8-7131</b>
Ref.Nr.: 6N0412249C	Ref.Nr.: 1K0412331C	Ref.Nr.: 038105243L	Ref.Nr.: 1J0 411 336 C	Ref.Nr.: 1K0199262AL	Ref.Nr.: 1K0199262AM	Ref.Nr.: 1K0412303B
<b>F8-7132</b>	<b>F8-7580</b>	<b>F8-7601</b>	<b>F8-7603</b>			
Ref.Nr.: 6N0413175A	Ref.Nr.: 1K0 511 353 Q	Ref.Nr.: 1K0511353N	Ref.Nr.: 3C0513353			

**Article Description****Article Nr.****Fitting Position****LEON (1P1)****05/2005 → 12/2012**

Top Strut Mounting	1.2 TSI, 1.4 16V, 1.4 TSI, 1.6, 1.6 LPG, 1.6 TDI, 1.8 TSI, 1.9 TDI, 2.0 Cupra R, 2.0 TDI, 2.0 TDI 16V, 2.0 TFSI	for OE: UC4; 2011→; <b>SP</b>	<b>F8-7603</b>		
Top Strut Mounting	1.6 MultiFuel, 1.6 TDI	for OE: UC4; <b>SP</b>	<b>F8-7603</b>		
Protective Cap/Bellow, shock absorber	All Models	for OE: 1JA, 1JC, UC4, UC5, UC6; <b>SP</b> , <b>ST</b>	<b>F8-7640</b>		H=176
Rubber Buffer, suspension	1.2 TSI, 1.4 16V, 1.4 TSI, 1.6, 1.6 LPG, 1.6 TDI, 1.8 TSI, 1.9 TDI, 2.0 Cupra R, 2.0 FSI, 2.0 TDI, 2.0 TDI 16V, 2.0 TFSI	for OE: G51; <b>SP</b>	<b>F8-7697</b>		H=55
Rubber Buffer, suspension	1.2 TSI, 1.4 16V, 1.4 TSI, 1.6, 1.6 LPG, 1.6 TDI, 1.8 TSI, 1.9 TDI, 2.0 Cupra R, 2.0 FSI, 2.0 TDI, 2.0 TDI 16V, 2.0 TFSI	for OE: G41, G50	<b>F8-7809</b>		H=55
Belt Pulley, crankshaft	1.8 TSI, 2.0 TFSI	Number of Ribs: 5; Parameter: 6PK	<b>F8-7880</b>		D=143
Control Arm-/Trailing Arm Bush	1.2 TSI, 1.4 16V, 1.4 TSI, 1.6, 1.6 LPG, 1.6 TDI, 1.8 TSI, 1.9 TDI, 2.0 Cupra R, 2.0 FSI, 2.0 TDI, 2.0 TDI 16V, 2.0 TFSI		<b>F8-7902</b>		H=60; d=12; D=42
Control Arm-/Trailing Arm Bush	1.2 TSI, 1.4 16V, 1.4 TSI, 1.6, 1.6 LPG, 1.6 TDI, 1.8 TSI, 1.9 TDI, 2.0 Cupra R, 2.0 FSI, 2.0 TDI, 2.0 TDI 16V, 2.0 TFSI		<b>F8-7907</b>		H=45; d=14; D=38
Control Arm-/Trailing Arm Bush	1.2 TSI, 1.4 16V, 1.4 TSI, 1.6, 1.6 LPG, 1.6 TDI, 1.8 TSI, 1.9 TDI, 2.0 Cupra R, 2.0 FSI, 2.0 TDI, 2.0 TDI 16V, 2.0 TFSI		<b>F8-7908</b>		H=45; d=12; D=38
Control Arm-/Trailing Arm Bush	1.2 TSI, 1.4 16V, 1.4 TSI, 1.6, 1.6 LPG, 1.6 TDI, 1.8 TSI, 1.9 TDI, 2.0 Cupra R, 2.0 FSI, 2.0 TDI, 2.0 TDI 16V, 2.0 TFSI		<b>F8-7909</b>		
Stabiliser Mounting	1.4 16V, 1.4 TSI, 1.6, 1.6 LPG, 1.8 TSI, 1.9 TDI, 2.0 Cupra R, 2.0 FSI, 2.0 TDI, 2.0 TDI 16V, 2.0 TFSI		<b>F8-7923</b>		d=20,7
Stabiliser Mounting	1.6, 1.9 TDI, 2.0 FSI, 2.0 TDI, 2.0 TDI 16V, 2.0 TFSI		<b>F8-7930</b>		d=18,5
Engine Mounting	1.9 TDI		<b>F8-7958</b>		
Engine Mounting	1.4 TSI		<b>F8-7959</b>		
Engine Mounting	1.4 16V, 1.4 TSI, 1.6, 1.6 LPG, 1.6 MultiFuel		<b>F8-7960</b>		
Engine Mounting	1.9 TDI	BLS, BXE;  6-speed	<b>F8-7961</b>		
Engine Mounting	2.0 FSI	6-speed	<b>F8-7961</b>		
Engine Mounting	1.9 TDI	BLS, BXE; Transmission Type: DSG	<b>F8-7962</b>		
Engine Mounting	2.0 TDI, 2.0 TDI 16V	Transmission Type: DSG	<b>F8-7962</b>		
Engine Mounting	2.0 TFSI	6-speed	<b>F8-7962</b>		
Engine Mounting	1.2 TSI, 1.4 16V, 1.4 TSI, 1.6 LPG		<b>F8-7965</b>		
Engine Mounting	1.8 TSI	BZB	<b>F8-7966</b>		
Engine Mounting	1.8 TSI	CDAA	<b>F8-7966</b>		
Engine Mounting	1.9 TDI, 2.0 TDI, 2.0 TDI 16V, 2.0 TFSI		<b>F8-7966</b>		
Engine Mounting	1.4 16V, 1.4 TSI, 1.9 TDI, 2.0 FSI, 2.0 TDI, 2.0 TFSI		<b>F8-7981</b>		

<b>F8-7603</b>	<b>F8-7640</b>	<b>F8-7697</b>	<b>F8-7809</b>	<b>F8-7880</b>	<b>F8-7902</b>	<b>F8-7907</b>
Ref.Nr.: 3C0513353	Ref.Nr.: 1K0513425A	Ref.Nr.: 1K0412303F	Ref.Nr.: 1K0412303E	Ref.Nr.: 06H105243F	Ref.Nr.: 1K0505171C	Ref.Nr.: 1K0505203A
<b>F8-7908</b>	<b>F8-7909</b>	<b>F8-7923</b>	<b>F8-7930</b>	<b>F8-7958</b>	<b>F8-7959</b>	<b>F8-7960</b>
Ref.Nr.: 1K0505279A	Ref.Nr.: 1K0505553 A	Ref.Nr.: 1K0511327AR	Ref.Nr.: 1K0511327AP	Ref.Nr.: 1K0199262AS	Ref.Nr.: 1K0199262CG	Ref.Nr.: 1K0199555L
<b>F8-7961</b>	<b>F8-7962</b>	<b>F8-7965</b>	<b>F8-7966</b>	<b>F8-7981</b>		
Ref.Nr.: 1K0199555N	Ref.Nr.: 1K0199555Q	Ref.Nr.: 1K0199855BA	Ref.Nr.: 1K0199855BB	Ref.Nr.: 1K0199867Q		

Article Description



Article Nr.

Fitting Position



<b>LEON (1P1)</b>			05/2005 → 12/2012		
Engine Mounting	1.6		F8-7981	↓	
Engine Mounting	1.8 TSI	BZB	F8-7981	↓	
Engine Mounting	2.0 TDI	BMN	F8-7981	↓	
Engine Mounting	2.0 TDI 16V	BKD	F8-7981	↓	
Engine Mounting	1.2 TSI, 1.4 16V, 1.4 TSI, 1.6, 1.6 LPG, 1.6 MultiFuel, 1.6 TDI, 1.9 TDI, 2.0 Cupra R, 2.0 FSI, 2.0 TDI, 2.0 TDI 16V, 2.0 TFSI		F8-7982	↑	
Engine Mounting	1.8 TSI	BZB	F8-7982	↑	
Engine Mounting	2.0 TFSI	BWJ	F8-7982	↑	
Control Arm-/Trailing Arm Bush	1.2 TSI, 1.4 16V, 1.4 TSI, 1.6, 1.6 LPG, 1.6 TDI, 2.0 FSI		F8-7991		
Engine Mounting	1.6 TDI, 2.0 TDI, 2.0 TDI 16V	6-speed	F8-8152	⊕	
<b>LEON (5F1)</b>			09/2012 →		
Rubber Buffer, suspension	1.2 TSI, 1.4 TSI, 1.6 TDI, 1.8 TFSI, 2.0 TDI	for OE: 2UA, G01, G02;	F8-7131	⊕ ⊕	H=70
Rubber Buffer, suspension	1.2 TSI, 1.4 TSI, 1.6 TDI, 1.8 TFSI, 2.0 TDI	for OE: 2UF, G03, G04;	F8-7131	⊕ ⊕	H=70
Protective Cap/Bellow, shock absorber	1.2 TSI, 1.4 TSI, 1.6 TDI, 1.8 TFSI, 2.0 TDI	ch.1P-D-000001→; for OE: 1JA, 1JC, 1JE, UC5, UC6;	F8-7640	⊕ ⊕	H=176
Rubber Buffer, suspension	1.2 TSI, 1.4 TSI, 1.6 TDI, 1.8 TFSI, 2.0 TDI	ch.1P-D-000001→; for OE: G41	F8-7809		H=55
Rubber Buffer, suspension	1.2 TSI, 1.4 TSI, 1.6 TDI, 1.8 TFSI, 2.0 TDI	ch.5F-D-000001→; for OE: 2UC, G02;	F8-7809		H=55
Belt Pulley, crankshaft	1.8 TFSI	Number of Ribs: 5; Parameter: 6PK	F8-7880		D=143
<b>LEON SC (5F5)</b>			02/2013 →		
Alternator Freewheel Clutch	2.0 TDI		F5-1085		
<b>LEON ST (5F8)</b>			08/2013 →		
Alternator Freewheel Clutch	1.6 TDI, 2.0 TDI		F5-1085		
<b>MALAGA (023A)</b>			11/1984 → 12/1993		
Dust Cover Kit, shock absorber	All Models		AK-735002	⊕ ⊕	
Dust Cover Kit, shock absorber	All Models		AK-735027	⊕ ⊕	
Dust Cover Kit, shock absorber	All Models		AK-735098		
Anti-Friction Bearing	1.2, 1.5, 1.7 D		F8-3017	⊕ ⊕	d=50; D=70
Control Arm-/Trailing Arm Bush	1.2, 1.5, 1.5 i, 1.5 i CAT, 1.7 D		F8-4042		H=44; d=10; D1=38; D2=42
Top Strut Mounting	All Models		F8-5957	⊕ ⊕	
Top Strut Mounting	1.2, 1.5, 1.5 i, 1.5 i CAT, 1.7 D		F8-5958	⊕ ⊕	
Engine Mounting	1.2, 1.2 i, 1.5, 1.5 i, 1.5 i CAT, 1.7 D		F8-6912		
Engine Mounting	1.2	12/1989 →	F8-6928	⊕	
Engine Mounting	1.5 i, 1.5 i CAT	08/1989 →	F8-6928	⊕	

<b>AK-735002</b>	<b>AK-735027</b>	<b>AK-735098</b>	<b>F5-1085</b>	<b>F8-3017</b>	<b>F8-4042</b>	<b>F8-5957</b>
Ref.Nr.:	Ref.Nr.:	Ref.Nr.:	Ref.Nr.: 045903119A	Ref.Nr.: 4400895	Ref.Nr.: 823407181	Ref.Nr.: SE141156228A
<b>F8-5958</b>	<b>F8-6912</b>	<b>F8-6928</b>	<b>F8-7131</b>	<b>F8-7640</b>	<b>F8-7809</b>	<b>F8-7880</b>
Ref.Nr.: 7635775	Ref.Nr.: 4433965	Ref.Nr.: 4433964	Ref.Nr.: 1K0412303B	Ref.Nr.: 1K0513425A	Ref.Nr.: 1K0412303E	Ref.Nr.: 06H105243F
<b>F8-7981</b>	<b>F8-7982</b>	<b>F8-7991</b>	<b>F8-8152</b>			
Ref.Nr.: 1K0199867Q	Ref.Nr.: 1K0199868Q	Ref.Nr.: 1K0407183G	Ref.Nr.: 1K0199555T			

**Article Description****Article Nr.****Fitting Position**

<b>MALAGA (023A)</b>			<b>11/1984 → 12/1993</b>		
Engine Mounting	1.5, 1.7 D		<b>F8-6928</b>		
<b>MARBELLA (28)</b>			<b>08/1986 → 10/1998</b>		
Anti-Friction Bearing	0.8, 0.9		<b>F8-3017</b>		d=50; D=70
Anti-Friction Bearing	0.9, 0.9 CAT		<b>F8-3036</b>		
Top Strut Mounting	All Models		<b>F8-5957</b>		
Top Strut Mounting	0.8, 0.9		<b>F8-5958</b>		
Control Arm-/Trailing Arm Bush	All Models		<b>G9-506</b>		H=37; d=9,2; D1=25; D2=36
<b>MARBELLA Box (028A)</b>			<b>01/1987 → 12/1993</b>		
Anti-Friction Bearing	All Models		<b>F8-3017</b>		d=50; D=70
Anti-Friction Bearing	0.8		<b>F8-3036</b>		
Top Strut Mounting	All Models		<b>F8-5957</b>		
Top Strut Mounting	All Models		<b>F8-5958</b>		
Control Arm-/Trailing Arm Bush	All Models		<b>G9-506</b>		H=37; d=9,2; D1=25; D2=36
<b>Mii (KF1_)</b>			<b>10/2011 →</b>		
Dust Cover Kit, shock absorber	1.0	<b>ST</b>	<b>AK-735410</b>		H=210
Alternator Freewheel Clutch	All Models		<b>F5-1064</b>		
Anti-Friction Bearing	All Models		<b>F8-3039</b>		H=14; d1=14; D=45
Top Strut Mounting	All Models		<b>F8-4067</b>		H=53; d=26; D=82
Rubber Buffer, suspension	All Models		<b>F8-5381</b>		H=37; D=76
Protective Cap/Bellow, shock absorber	1.0		<b>F8-5683</b>		H=210
Top Strut Mounting	All Models		<b>F8-6280</b>		H=53; d=26; D=82
Rubber Buffer, suspension	1.0	for OE: 1JA; <b>ST</b>	<b>F8-6723</b>		H=124
Rubber Buffer, suspension	1.0	for OE: 1JB; <b>Δ</b>	<b>F8-6723</b>		H=124
Top Strut Mounting	1.0	for OE: 1J0412319C	<b>F8-7133</b>		
Protective Cap/Bellow, shock absorber	All Models		<b>F8-7486</b>		
Rubber Buffer, suspension	All Models	for OE: G01; <b>ST</b>	<b>F8-7891</b>		H=63
Rubber Buffer, suspension	All Models	for OE: G03; <b>SP</b>	<b>F8-7892</b>		H=53
Rubber Buffer, suspension	All Models	for OE: 1JC; <b>SP</b>	<b>F8-7893</b>		H=122
Control Arm-/Trailing Arm Bush	All Models		<b>F8-7978</b>		
<b>RONDA (022A)</b>			<b>06/1982 → 11/1988</b>		
Dust Cover Kit, shock absorber	1.2, 1.4, 1.7 Diesel		<b>AK-735002</b>		

<b>AK-735002</b>	<b>AK-735005</b>	<b>AK-735410</b>	<b>F5-1064</b>	<b>F8-3017</b>	<b>F8-3036</b>	<b>F8-3039</b>
Ref.Nr.:	Ref.Nr.:	Ref.Nr.: 1J0412303	Ref.Nr.: 03C903119D	Ref.Nr.: 4400895	Ref.Nr.: 377412335A	Ref.Nr.: 357412249A
<b>F8-4067</b>	<b>F8-5381</b>	<b>F8-5683</b>	<b>F8-5957</b>	<b>F8-5958</b>	<b>F8-6280</b>	<b>F8-6723</b>
Ref.Nr.: 1J0412331B	Ref.Nr.: 1J0512149B	Ref.Nr.: 357413175A	Ref.Nr.: SE141156228A	Ref.Nr.: 7635775	Ref.Nr.: 6R0412249	Ref.Nr.: 6Q0512131B
<b>F8-6928</b>	<b>F8-7133</b>	<b>F8-7486</b>	<b>F8-7891</b>	<b>F8-7892</b>	<b>F8-7893</b>	<b>F8-7978</b>
Ref.Nr.: 4433964	Ref.Nr.: 1J0412319C	Ref.Nr.: 1S0513425A	Ref.Nr.: 1S0412303	Ref.Nr.: 1S0412303A	Ref.Nr.: 1S0511351B	Ref.Nr.: 357407182F

Article Description



Article Nr.

Fitting Position



<b>RONDA (022A)</b>		<b>06/1982 → 11/1988</b>	
Dust Cover Kit, shock absorber	1.2, 1.7 Diesel		AK-735005
Dust Cover Kit, shock absorber	1.2, 1.4, 1.7 Diesel	08/1986 →	AK-735027
Anti-Friction Bearing	All Models		F8-3017  d=50; D=70
Top Strut Mounting	1.2, 1.4, 1.5, 1.6		F8-5957
Top Strut Mounting	1.7 Diesel	10/1983 →;	F8-5957
Top Strut Mounting	1.2, 1.5, 1.6, 1.7 Diesel		F8-5958
Engine Mounting	1.2, 1.4, 1.5		F8-6912
Engine Mounting	1.2, 1.4, 1.5		F8-6928
<b>TERRA (24)</b>		<b>02/1987 → 12/1996</b>	
Rubber Buffer, silencer	All Models		F8-4026 H=12; W=57, 60
Top Strut Mounting	All Models		F8-5958
Control Arm-/Trailing Arm Bush	All Models		G9-506  H=37; d=9,2; D1=25; D2=36
<b>TERRA Box (024A)</b>		<b>01/1987 → 12/1995</b>	
Rubber Buffer, silencer	All Models		F8-4026 H=12; W=57, 60
Top Strut Mounting	All Models		F8-5958
Control Arm-/Trailing Arm Bush	All Models		G9-506  H=37; d=9,2; D1=25; D2=36
<b>TOLEDO (1L)</b>		<b>05/1991 → 03/1999</b>	
Dust Cover Kit, shock absorber	1.6 i, 1.8 16V, 1.8 i, 1.9 D, 1.9 TD, 1.9 TDI, 2.0 i, 2.0 i 16V		AK-732516
Dust Cover Kit, shock absorber	1.6 i, 1.8 16V, 1.8 i, 1.9 D, 1.9 TD, 1.9 TDI, 2.0 i, 2.0 i 16V		AK-733023
Alternator Freewheel Clutch	1.9 TDI		F5-1007
Engine Mounting	1.6 i, 1.8 i, 1.9 D, 1.9 TD, 1.9 TDI, 2.0 i		F8-1003  H=120; d=11; D=106; Thick. [mm]=62, 76
Engine Mounting	1.9 D, 1.9 TD		F8-1004  H=114; D=106
Engine Mounting	1.6 i, 1.8 i		F8-1005  H=109; d1=6; d2=12; D=116
Control Arm-/Trailing Arm Bush	1.6 i, 1.8 16V, 1.8 i, 1.9 D, 1.9 TD, 1.9 TDI, 2.0 i, 2.0 i 16V	without guide sleeve	F8-1007  H1=26; H2=41; d=17; D1=60; D2=68
Control Arm-/Trailing Arm Bush	1.6 i, 1.8 16V, 1.8 i, 1.9 D, 1.9 TD, 1.9 TDI, 2.0 i, 2.0 i 16V	with guide sleeve	F8-1007S  H1=26; H2=41; d=17; D1=60; D2=68
Repair Kit, link	1.6 i, 1.8 16V, 1.8 i, 1.9 D, 1.9 TD, 1.9 TDI, 2.0 i, 2.0 i 16V	with guide sleeve	F8-1008  H1=24; H2=41; d=17; D=60
Top Strut Mounting	1.6 i, 1.8 16V, 1.8 i, 1.9 D, 1.9 TD, 1.9 TDI, 2.0 i, 2.0 i 16V		F8-1009B  d=14; D=132
Mounting, axle beam	1.6 i, 1.8 16V, 1.8 i, 1.9 D, 1.9 TD, 1.9 TDI, 2.0 i, 2.0 i 16V		F8-1010  H=90; d=12; D1=22; D2=44

<b>AK-732516</b>	<b>AK-733023</b>	<b>AK-735005</b>	<b>AK-735027</b>	<b>F5-1007</b>	<b>F8-1003</b>	<b>F8-1004</b>
Ref.Nr.:	Ref.Nr.: 191412303	Ref.Nr.:	Ref.Nr.:	Ref.Nr.: 028903119AQ	Ref.Nr.: 191199262A	Ref.Nr.: 357199279C
<b>F8-1005</b>	<b>F8-1007</b>	<b>F8-1007S</b>	<b>F8-1008</b>	<b>F8-1009B</b>	<b>F8-1010</b>	<b>F8-1010S</b>
Ref.Nr.: 191199279E	Ref.Nr.: 191407181A	Ref.Nr.: 191407181A	Ref.Nr.: 191407181E	Ref.Nr.: 176412329	Ref.Nr.: 191501541	Ref.Nr.: 191501541
<b>F8-3017</b>	<b>F8-4026</b>	<b>F8-5957</b>	<b>F8-5958</b>	<b>F8-6912</b>	<b>F8-6928</b>	<b>G9-506</b>
Ref.Nr.: 4400895	Ref.Nr.: 817253147	Ref.Nr.: SE141156228A	Ref.Nr.: 7635775	Ref.Nr.: 4433965	Ref.Nr.: 4433964	Ref.Nr.: 0004288726



**Article Description****Article Nr.****Fitting Position**

<b>TOLEDO (1L)</b>			<b>05/1991 → 03/1999</b>		
Repair Set, axle beam	1.6 i, 1.8 16V, 1.8 i, 1.9 D, 1.9 TD, 1.9 TDI, 2.0 i, 2.0 i 16V		<b>F8-1010S</b>		
Engine Mounting	1.6 i	01/1997 →	<b>F8-1015</b>		H=82; D1=55; D2=71
Engine Mounting	1.8 16V		<b>F8-1025</b>		H=128; D=100; W=180
Top Strut Mounting	1.6 i, 1.8 i, 1.9 D, 2.0 i, 2.0 i 16V		<b>F8-1034</b>		H=50; d=27; D=98
Top Strut Mounting	1.6 i, 1.9 TD, 1.9 TDI	01/1997 →;	<b>F8-1034</b>		H=50; d=27; D=98
Top Strut Mounting	1.6 i, 1.8 i, 1.9 D, 2.0 i, 2.0 i 16V		<b>F8-1034S</b>		H=51; d=14; D=96
Top Strut Mounting	1.6 i, 1.9 TD, 1.9 TDI	01/1997 →;	<b>F8-1034S</b>		H=51; d=14; D=96
Anti-Friction Bearing	All Models		<b>F8-3039</b>		H=14; d1=14; D=45
Engine Mounting	1.8 16V, 2.0 i		<b>F8-3040</b>		H=116; D=111
Stabiliser Mounting	1.6 i, 1.8 16V, 1.8 GT, 1.8 i, 1.9 D, 1.9 TD, 2.0 i 16V		<b>F8-3042</b>		H=33; d=17; W=35
Stabiliser Mounting	1.6 i, 1.9 TDI, 2.0 i	ch.→1L-VR025000	<b>F8-3042</b>		H=33; d=17; W=35
Flange, carburettor	1.6 i, 1.8 i		<b>F8-3048</b>		H=27; d=40
Mounting, axle beam	2.0 i 16V		<b>F8-4008</b>		H1=54; H2=90; d=12; D=56
Repair Set, axle beam	2.0 i 16V	with fastening material	<b>F8-4008S</b>		H1=54; H2=90; d=12; D=56
Engine Mounting	1.6 i, 1.9 TDI, 2.0 i 16V		<b>F8-4016</b>		
Clamp, silencer	1.6 i, 1.8 16V, 1.8 i, 1.9 D, 1.9 TD, 1.9 TDI, 2.0 i, 2.0 i 16V	ch.→1L-TR018015	<b>F8-4027</b>		H=17; W=53, 61
Rubber Buffer, suspension	1.6 i, 1.8 16V, 1.8 GT, 1.8 i, 1.9 D, 1.9 TD, 2.0 i	ch.→1L-ZR054543; →1996	<b>F8-4063</b>		H=83; d1=18; d2=25; D1=48; D2=60
Protective Cap/Bellow, shock absorber	1.6 i, 1.8 16V, 1.8 i, 1.9 D, 1.9 TD, 2.0 i		<b>F8-4064</b>		H=90; d1=50; d2=71; D1=66; D2=77
Bellow, steering	1.6 i, 1.8 16V, 1.8 i, 1.9 D, 1.9 TD, 1.9 TDI, 2.0 i, 2.0 i 16V		<b>F8-4069</b>		
Bellow, steering	1.6 i, 1.8 16V, 1.8 i, 1.9 D, 1.9 TD, 1.9 TDI, 2.0 i		<b>F8-4075</b>		H=200; d=10; D=48
Bellow, steering	2.0 i 16V	for steering manufacturer: TRW;	<b>F8-4075</b>		H=200; d=10; D=48
Mounting, steering gear	1.6 i, 1.8 16V, 1.8 i, 1.9 D, 1.9 TD, 1.9 TDI, 2.0 i, 2.0 i 16V		<b>F8-5145</b>		d1=50.7; d2=48.3
Engine Mounting	1.6 i	Brown; 01/1997 →	<b>F8-5346</b>		
Spring Mounting	1.6 i, 1.8 16V, 1.8 i, 1.9 D, 1.9 TD, 1.9 TDI, 2.0 i, 2.0 i 16V		<b>F8-5393</b>		
Stabiliser Mounting	1.6 i, 1.9 TDI	ch.1L-VR025501→	<b>F8-5395</b>		d=19
Engine Mounting	1.9 TDI, 2.0 i 16V		<b>F8-5396</b>		
Top Strut Mounting	1.6 i, 1.8 i, 1.9 D, 1.9 TD, 1.9 TDI, 2.0 i, 2.0 i 16V		<b>F8-5402</b>		
Top Strut Mounting	1.6 i, 1.9 D, 1.9 TD, 1.9 TDI, 2.0 i 16V	ch.→1L-X-009000	<b>F8-5403</b>		
Top Strut Mounting	1.8 i	ADZ	<b>F8-5403</b>		
Top Strut Mounting	1.8 i, 2.0 i		<b>F8-5403</b>		
Engine Mounting	1.9 TDI	ch.→1L-X-009000	<b>F8-5491</b>		

<b>F8-1010S</b>	<b>F8-1015</b>	<b>F8-1025</b>	<b>F8-1034</b>	<b>F8-1034S</b>	<b>F8-3039</b>	<b>F8-3040</b>
Ref.Nr.: 191501541	Ref.Nr.: 357199402	Ref.Nr.: 191199262C	Ref.Nr.: 357412331A	Ref.Nr.: 7201848S1	Ref.Nr.: 357412249A	Ref.Nr.: 357199279
<b>F8-3042</b>	<b>F8-3048</b>	<b>F8-4008</b>	<b>F8-4008S</b>	<b>F8-4016</b>	<b>F8-4027</b>	<b>F8-4063</b>
Ref.Nr.: 191411314	Ref.Nr.: 050129761B	Ref.Nr.: 1H0501541A	Ref.Nr.: 1H0501541	Ref.Nr.: 1H0199262G	Ref.Nr.: 171253147A	Ref.Nr.: 191412303A
<b>F8-4064</b>	<b>F8-4069</b>	<b>F8-4075</b>	<b>F8-5145</b>	<b>F8-5346</b>	<b>F8-5393</b>	<b>F8-5395</b>
Ref.Nr.: 191412135	Ref.Nr.: 171419831B	Ref.Nr.: 357422831	Ref.Nr.: 191419883	Ref.Nr.: 1H0199609G	Ref.Nr.: 1H0512149	Ref.Nr.: 1H0411314

Article Description



Article Nr.

Fitting Position



<b>TOLEDO (1L)</b>		<b>05/1991 → 03/1999</b>	
Engine Mounting	1.6 i, 1.8 16V, 1.8 i, 1.9 D, 1.9 TD, 1.9 TDI, 2.0 i, 2.0 i 16V		F8-5554  ⊕ ⊕ ⊕ H=39.5; d1=16; d2=24; D=50
Rubber Buffer, suspension	1.6 i	ABN	F8-5594  ⊕ ⊕ ⊕ H=146; d=10.5; D=55.6
Rubber Buffer, suspension	1.6 i, 1.8 16V, 1.8 GT, 1.8 i, 1.9 D, 1.9 TD, 1.9 TDI, 2.0 i 16V		F8-5594  ⊕ ⊕ ⊕ H=146; d=10.5; D=55.6
Rubber Buffer, suspension	1.8 i	ABS	F8-5594  ⊕ ⊕ ⊕ H=146; d=10.5; D=55.6
Rubber Buffer, suspension	2.0 i	2E	F8-5594  ⊕ ⊕ ⊕ H=146; d=10.5; D=55.6
Belt Pulley, crankshaft	1.9 D, 1.9 TD, 1.9 TDI	ch.→1L-X-009000; Number of Ribs: 5; Parameter: 6PK	F8-5649  H=31.5; d=30.02; Mounting points diam.[mm]=8.5; D1=161.5; D2=160.5
Protective Cap/Bellow, shock absorber	All Models		F8-5747  ⊕ ⊕ ⊕ H=90
Rubber Buffer, suspension	1.6 i, 1.8 16V, 1.8 GT, 1.8 i, 1.9 D, 1.9 TD, 2.0 i	ch.1L-TR000001→	F8-5993  ⊕ ⊕ ⊕ H=83
Rubber Buffer, suspension	1.6 i, 1.9 TDI		F8-5993  ⊕ ⊕ ⊕ H=83
Rubber Buffer, suspension	2.0 i 16V	→1996	F8-5993  ⊕ ⊕ ⊕ H=83
Repair Kit, suspension strut	1.6 i, 1.8 16V, 1.8 i, 1.9 D, 1.9 TD, 1.9 TDI, 2.0 i, 2.0 i 16V		F8-6382  ⊕
Sleeve, control arm mounting	All Models		F8-6699  ⊕ ⊕ ⊕ d=16; L=50; D=17
Engine Mounting	1.6 i, 1.9 D, 1.9 TD, 2.0 i, 2.0 i 16V	ch.→1L-X-009000	F8-6922  ⊕ H=65
Engine Mounting	1.8 16V, 1.8 i		F8-6922  ⊕ H=65
Bellow, driveshaft	1.9 D		F8-7722  ⊕ ⊕ ⊕ d1=26; d2=78; L=110
Flange, carburettor	1.6 i	ABN, EZ; not for  1F	F8-7743
Control Arm-/Trailing Arm Bush	All Models		F8-7978  ⊕ ⊕ ⊕
Control Arm-/Trailing Arm Bush	1.6 i, 1.8 16V, 1.8 i, 1.9 D, 1.9 TD, 1.9 TDI, 2.0 i, 2.0 i 16V		G9-648  ⊕ ⊕ ⊕ ↓ H=54; d=12; D1=33; D2=36
Bellow, steering	All Models	with clamps;	LM-10003S  ⊕ d1=9; d2=43; L [mm]=210
Bellow, steering	All Models	with clamps;	LM-10006S  ⊕ d1=10; d2=41; L [mm]=210
Bellow, steering	1.6 i, 1.8 16V, 1.8 i, 1.9 D, 1.9 TD, 2.0 i, 2.0 i 16V	ch.→1L-ZR026525; with clamps;	LM-10024S  ⊕ d1=25; d2=41; L [mm]=120
Bellow, steering	1.6 i, 1.8 GT	with clamps;	LM-10024S  ⊕ d1=25; d2=41; L [mm]=120
Bellow, steering	1.6 i, 1.8 16V, 1.8 i, 1.9 D, 1.9 TD, 2.0 i, 2.0 i 16V	ch.→1L-ZR026525; with clamps;	LM-10050S  ⊕ d1=25; d2=39; L [mm]=126
Bellow, steering	1.6 i, 1.8 GT	with clamps;	LM-10050S  ⊕ d1=25; d2=39; L [mm]=126
Bellow, driveshaft	1.9 D		M-830220  ⊕ ⊕ ⊕
Bellow Set, drive shaft	1.9 D		MK-830220  ⊕
<b>TOLEDO Mk II (1M2)</b>		<b>10/1998 → 05/2006</b>	
Dust Cover Kit, shock absorber	1.4 16V, 1.6, 1.8 20V, 1.9 TDI, 2.3 V5		AK-735039  ⊕ ⊕ ⊕
Dust Cover Kit, shock absorber	1.4 16V, 1.6, 1.6 16V, 1.8 20V, 1.8 20VT, 1.9 SDI, 1.9 TDI, 2.3 V5, 2.3 V5 20V		AK-735095  ⊕ ⊕ ⊕
Dust Cover Kit, shock absorber	All Models		AK-735410  ⊕ ⊕ ⊕ H=210

AK-735039	AK-735095	AK-735410	F5-1004	F8-5554	F8-5594	F8-5649
Ref.Nr.: 357413175A	Ref.Nr.: 1J0512131B	Ref.Nr.: 1J0412303	Ref.Nr.: 038903119T	Ref.Nr.: 191199233	Ref.Nr.: 191512131B	Ref.Nr.: 028105243T
F8-5747	F8-5993	F8-6382	F8-6699	F8-6922	F8-7722	F8-7743
Ref.Nr.: 191513425	Ref.Nr.: 357412303F	Ref.Nr.: 191512333S	Ref.Nr.: 191407190A	Ref.Nr.: 191199381A	Ref.Nr.: 191407285F	Ref.Nr.: 037129761
F8-7978	G9-648	LM-10003S	LM-10006S	LM-10024S	LM-10050S	M-830220
Ref.Nr.: 357407182F	Ref.Nr.: 357407182	Ref.Nr.: 357422831A	Ref.Nr.: 1H0422831B	Ref.Nr.: 171419831B	Ref.Nr.: 171419831C	Ref.Nr.: 191498203C

**Article Description****Article Nr.****Fitting Position**

<b>TOLEDO Mk II (1M2)</b>		<b>10/1998 → 05/2006</b>	
Alternator Freewheel Clutch	1.8 20V, 1.8 AWD, 1.9 SDI, 1.9 TDI, 2.3 V5, 2.3 V5 20V		<b>F5-1004</b>
Anti-Friction Bearing	1.4 16V, 1.6, 1.6 16V, 1.8 20V, 1.8 20VT, 1.9 SDI, 1.9 TDI, 2.3 V5, 2.3 V5 20V		<b>F8-3039</b>
Top Strut Mounting	1.4 16V, 1.6, 1.6 16V, 1.8 20V, 1.8 20VT, 1.9 SDI, 1.9 TDI, 2.3 V5, 2.3 V5 20V		<b>F8-4067</b>
Stabiliser Mounting	1.6 16V, 1.8 20V, 1.9 SDI	ch.→1M-4-136650; 01/2002 →; only in connection with: F8-6579; Stabi. Diam. [mm]= 19	<b>F8-5215</b>
Stabiliser Mounting	1.6, 1.8 20VT, 1.9 TDI, 2.3 V5 20V	ch.→1M-4-136650; only in connection with: F8-6579; Stabi. Diam. [mm]= 19	<b>F8-5215</b>
Stabiliser Mounting	2.3 V5	only in connection with: F8-6579; Stabi. Diam. [mm]= 19	<b>F8-5215</b>
Stabiliser Mounting	1.4 16V, 1.6 16V, 1.8 20V, 1.9 TDI, 2.3 V5, 2.3 V5 20V	only in connection with: F8-6579; Stabi. Diam. [mm]= 23	<b>F8-5220</b>
Stabiliser Mounting	1.4 16V, 1.6 16V, 1.8 20V, 1.9 TDI, 2.3 V5, 2.3 V5 20V	only in connection with: F8-6579; Stabi. Diam. [mm]= 21	<b>F8-5221</b>
Top Strut Mounting	1.4 16V, 1.6, 1.6 16V, 1.8 20V, 1.8 20VT, 1.9 TDI, 2.3 V5, 2.3 V5 20V	not for equipment variant: 1JC, UB5	<b>F8-5380</b>
Top Strut Mounting	1.9 SDI		<b>F8-5380</b>
Rubber Buffer, suspension	1.4 16V, 1.6, 1.6 16V, 1.8 20V, 1.8 20VT, 1.9 SDI, 1.9 TDI, 2.3 V5, 2.3 V5 20V		<b>F8-5381</b>
Engine Mounting	1.9 SDI		<b>F8-5384</b>
Engine Mounting	1.6, 1.8 20V, 1.9 TDI		<b>F8-5386</b>
Mounting, automatic transmission	1.8 20V, 1.9 TDI		<b>F8-5387</b>
Mounting, automatic transmission	2.3 V5	5-speed	<b>F8-5387</b>
Engine Mounting	1.4 16V, 1.6 16V		<b>F8-5388</b>
Engine Mounting	1.6		<b>F8-5390</b>
Spring Cap	1.4 16V, 1.6, 1.6 16V, 1.8 20V, 1.8 20VT, 1.8 AWD, 1.9 SDI, 1.9 TDI, 2.3 V5, 2.3 V5 20V		<b>F8-5580</b>
Belt Pulley, crankshaft	1.8 20V, 1.8 20VT		<b>F8-5650</b>
Protective Cap/Bellow, shock absorber	All Models		<b>F8-5683</b>
Mounting, axle beam	1.4 16V, 1.6, 1.8 20V, 1.8 20VT, 1.8 AWD, 1.9 SDI, 1.9 TDI, 2.3 V5, 2.3 V5 20V		<b>F8-5907</b>
Mounting, axle beam	1.6 16V	ENGINE AZD	<b>F8-5907</b>
Rubber Buffer, suspension	1.4 16V, 1.6 16V, 1.8 20V, 1.8 20VT, 1.8 AWD, 1.9 SDI, 1.9 TDI, 2.3 V5 20V	for OE: 1GB, G10; →2003; Δ	<b>F8-5993</b>
Rubber Buffer, suspension	1.6, 2.3 V5	for OE: 1GB, G10; Δ	<b>F8-5993</b>
Rubber Buffer, suspension	1.8 AWD, 1.9 TDI	for OE: G10; →2003; Δ	<b>F8-5993</b>

<b>F5-1004</b>	<b>F8-3039</b>	<b>F8-4067</b>	<b>F8-5215</b>	<b>F8-5220</b>	<b>F8-5221</b>	<b>F8-5380</b>
Ref.Nr.: 038903119T	Ref.Nr.: 357412249A	Ref.Nr.: 1J0412331B	Ref.Nr.: 1J0411314B	Ref.Nr.: 1J0411314G	Ref.Nr.: 1J0411314R	Ref.Nr.: 1J0513353G
<b>F8-5381</b>	<b>F8-5384</b>	<b>F8-5386</b>	<b>F8-5387</b>	<b>F8-5388</b>	<b>F8-5390</b>	<b>F8-5580</b>
Ref.Nr.: 1J0512149B	Ref.Nr.: 1J0199555AL	Ref.Nr.: 1J0199555AJ	Ref.Nr.: 1J0199555AH	Ref.Nr.: 1J0199262BK	Ref.Nr.: 1J0199262BE	Ref.Nr.: 1J0412341
<b>F8-5650</b>	<b>F8-5683</b>	<b>F8-5907</b>	<b>F8-5993</b>	<b>F8-5996</b>		
Ref.Nr.: 06A105243E	Ref.Nr.: 357413175A	Ref.Nr.: 1J0199429	Ref.Nr.: 357412303F	Ref.Nr.: 1H0412303B		

Article Description

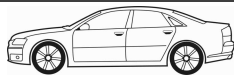

Article Nr.

Fitting Position



TOLEDO Mk II (1M2)				10/1998 → 05/2006	
Rubber Buffer, suspension	1.4 16V, 1.6 16V, 1.8 20V, 1.8 20VT, 1.9 TDI, 2.3 V5 20V	ch.1M-1-035001→; for OE: G22, G23, G24; →2004; <b>ST</b>	<b>F8-5996</b>		H=63
Rubber Buffer, suspension	1.4 16V, 1.6 16V, 1.8 20V, 1.8 20VT, 1.9 TDI, 2.3 V5 20V	ch.1M-1-035001→; for OE: G25; →2004; <b>SP</b>	<b>F8-5996</b>		H=63
Rubber Buffer, suspension	1.4 16V, 1.6 16V, 1.8 20V, 1.8 20VT, 1.9 TDI, 2.3 V5 20V	ch.1M-1-035001→; for OE: G52; →2004; <b>OI</b>	<b>F8-5996</b>		H=63
Rubber Buffer, suspension	1.4 16V, 1.6, 1.6 16V, 1.8 20V, 1.8 20VT, 1.8 AWD, 1.9 SDI, 1.9 TDI, 2.3 V5, 2.3 V5 20V	ch.→1M-1-035000; for OE: 1GA, 1GD, 1GG, G22, G23, G24; <b>ST</b>	<b>F8-5996</b>		H=63
Rubber Buffer, suspension	1.6, 1.8 AWD, 1.9 SDI, 2.3 V5	ch.1M-1-035001→; for OE: G22, G23, G24; <b>ST</b>	<b>F8-5996</b>		H=63
Rubber Buffer, suspension	1.6, 1.8 AWD, 1.9 SDI, 2.3 V5	ch.1M-1-035001→; for OE: G25; <b>SP</b>	<b>F8-5996</b>		H=63
Rubber Buffer, suspension	1.6, 1.8 AWD, 1.9 SDI, 2.3 V5	ch.1M-1-035001→; for OE: G52; <b>OI</b>	<b>F8-5996</b>		H=63
Rubber Buffer, suspension	1.8 AWD	for OE: G22, G23, G24; <b>ST</b>	<b>F8-5996</b>		H=63
Rubber Buffer, suspension	1.8 AWD	for OE: G25; <b>SP</b>	<b>F8-5996</b>		H=63
Rubber Buffer, suspension	1.8 AWD	for OE: G52; <b>OI</b>	<b>F8-5996</b>		H=63
Rubber Buffer, suspension	1.8 AWD, 1.9 TDI	for OE: G22, G23, G24; →2004; <b>ST</b>	<b>F8-5996</b>		H=63
Rubber Buffer, suspension	1.8 AWD, 1.9 TDI	for OE: G25; →2004; <b>SP</b>	<b>F8-5996</b>		H=63
Rubber Buffer, suspension	1.8 AWD, 1.9 TDI	for OE: G52; →2004; <b>OI</b>	<b>F8-5996</b>		H=63
Rubber Buffer, suspension	1.4 16V, 1.6, 1.6 16V, 1.8 20V, 1.8 20VT, 1.9 TDI, 2.3 V5, 2.3 V5 20V	△	<b>F8-6012</b>		H=143
Top Strut Mounting	1.4 16V, 1.6, 1.6 16V, 1.8 20V, 1.8 20VT, 1.9 SDI, 1.9 TDI, 2.3 V5, 2.3 V5 20V	for OE: 1JC, UB5	<b>F8-6040</b>		
Rubber Buffer, suspension	1.4 16V, 1.6 16V, 1.8 20V, 1.8 20VT, 1.9 TDI, 2.3 V5 20V	ch.1M-1-035001→; for OE: G26, G61, G62, G63, G99; →2004; <b>SP</b>	<b>F8-6041</b>		H=53
Rubber Buffer, suspension	1.4 16V, 1.6, 1.9 SDI, 2.3 V5, 2.3 V5 20V	ch.→1M-1-035000; for OE: 1GD, 1GL, G25, G26, G99; <b>SP</b>	<b>F8-6041</b>		H=53
Rubber Buffer, suspension	1.6 16V, 1.8 20V, 1.8 20VT, 1.8 AWD, 1.9 TDI	ch.→1M-1-035000; for OE: 1GL, G25, G26, G99; <b>SP</b>	<b>F8-6041</b>		H=53
Rubber Buffer, suspension	1.6, 1.8 AWD, 1.9 SDI, 2.3 V5	ch.1M-1-035001→; for OE: G26, G61, G62, G63, G99; <b>SP</b>	<b>F8-6041</b>		H=53
Rubber Buffer, suspension	1.8 AWD	for OE: G26, G61, G62, G63, G99; <b>SP</b>	<b>F8-6041</b>		H=53
Rubber Buffer, suspension	1.8 AWD, 1.9 TDI	for OE: G26, G61, G62, G63, G99; →2004; <b>SP</b>	<b>F8-6041</b>		H=53
Protective Cap/Bellow, shock absorber	1.4 16V, 1.6, 1.6 16V, 1.8 20V, 1.8 20VT, 1.9 SDI, 1.9 TDI, 2.3 V5, 2.3 V5 20V	for OE: 1JB; △	<b>F8-6044</b>		H=160
Mounting, axle beam	1.4 16V, 1.6, 1.6 16V, 1.8 20V, 1.8 20VT, 1.9 SDI, 1.9 TDI, 2.3 V5, 2.3 V5 20V		<b>F8-6076</b>		d=12; L=90; D=69
Repair Set, axle beam	1.4 16V, 1.6, 1.6 16V, 1.8 20V, 1.8 20VT, 1.9 SDI, 1.9 TDI, 2.3 V5, 2.3 V5 20V	ch.1M-X-000001→; ch.→1M-X-025000	<b>F8-6077</b>		H=90; D=69
Top Strut Mounting	1.4 16V, 1.6, 1.6 16V, 1.8 20V, 1.8 20VT, 1.9 SDI, 1.9 TDI, 2.3 V5, 2.3 V5 20V	not for equipment variant: G92; ☺	<b>F8-6280</b>		H=53; d=26; D=82
Belt Pulley, crankshaft	1.9 TDI	ch.1M-X-000001→; Number of Ribs: 5; Parameter: 6PK	<b>F8-6392</b>		H=47; d=30; D=143

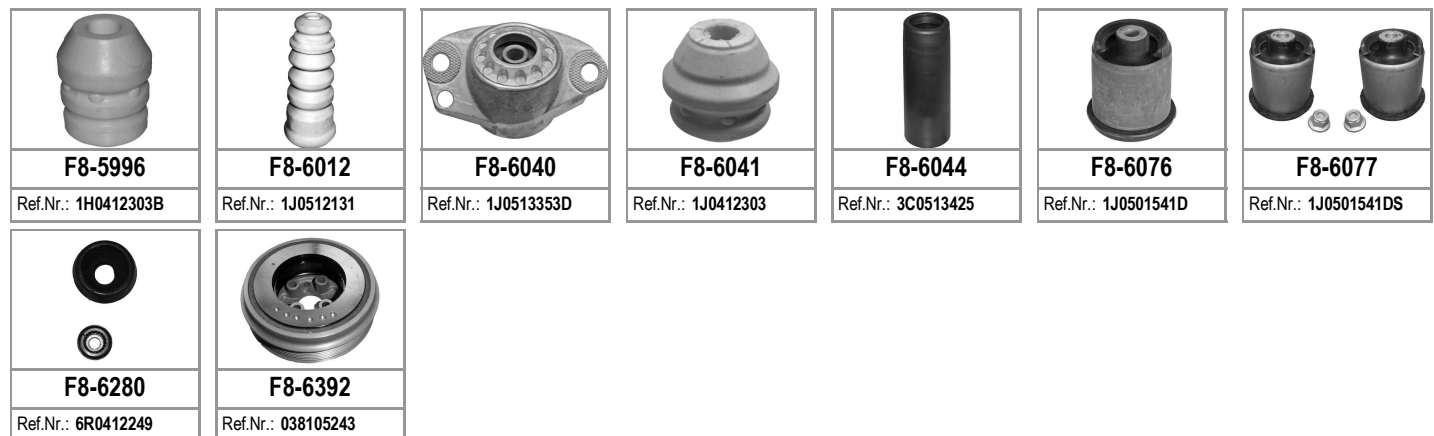

**Article Description****Article Nr.****Fitting Position****TOLEDO Mk II (1M2) 10/1998 → 05/2006**

Belt Pulley, crankshaft	1.9 TDI	Engine →435000; Number of Ribs: 5; Parameter: 6PK	<b>F8-6392</b>		H=47; d=30; D=143
Belt Pulley, crankshaft	1.9 TDI	ch.1M-3R099131→; Number of Ribs: 5; Parameter: 6PK	<b>F8-6396</b>		H=41.6; d=30; Mounting points diam.[mm]=7, 8.6; D=139.7
Belt Pulley, crankshaft	1.9 TDI	Engine435001→; Number of Ribs: 5; Parameter: 6PK	<b>F8-6396</b>		H=41.6; d=30; Mounting points diam.[mm]=7, 8.6; D=139.7
Control Arm-/Trailing Arm Bush	1.6		<b>F8-6463</b>		H=64; d=12; D=60
Control Arm-/Trailing Arm Bush	1.8 AWD		<b>F8-6464</b>		H=41; d=13.5; W=60
Bracket, stabilizer mounting	1.4 16V, 1.6, 1.6 16V, 1.8 20V, 1.8 20VT, 1.8 AWD, 1.9 SDI, 1.9 TDI, 2.3 V5, 2.3 V5 20V		<b>F8-6579</b>		
Bracket, stabilizer mounting	1.9 TDI	ALH	<b>F8-6579</b>		
Engine Mounting	1.9 TDI		<b>F8-6960</b>		
Top Strut Mounting	All Models	for OE: 1J0412319C	<b>F8-7133</b>		
Belt Pulley, crankshaft	1.9 TDI	ch.→1M-3R099130	<b>F8-7864</b>		
Control Arm-/Trailing Arm Bush	1.4 16V, 1.6, 1.6 16V, 1.8 AWD, 1.9 SDI, 1.9 TDI, 2.3 V5, 2.3 V5 20V		<b>F8-7978</b>		
Control Arm-/Trailing Arm Bush	1.4 16V, 1.6, 1.6 16V, 1.8 20V, 1.8 20VT, 1.9 TDI, 2.3 V5, 2.3 V5 20V		<b>G9-648</b>		H=54; d=12; D1=33; D2=36
Control Arm-/Trailing Arm Bush	1.4 16V, 1.6, 1.6 16V, 1.8 20V, 1.8 20VT, 1.9 TDI, 2.3 V5, 2.3 V5 20V		<b>G9-649</b>		H1=25; H2=41; d=13; D=60
Bellow, steering	All Models	with clamps;	<b>LM-10020S</b>		d1=16; d2=48; L [mm]=179

**TOLEDO III (5P2) 04/2004 → 05/2009**

Alternator Freewheel Clutch	1.6, 1.8 TFSI, 1.9 TDI, 2.0 FSI, 2.0 TDI, 2.0 TDI 16V, 2.0 TFSI		<b>F5-1004</b>		
Alternator Freewheel Clutch	1.8 TFSI		<b>F5-1044</b>		
Control Arm-/Trailing Arm Bush	1.6, 1.8 TFSI, 1.9 TDI, 2.0 FSI, 2.0 TDI, 2.0 TDI 16V, 2.0 TFSI		<b>F8-5633</b>		
Belt Pulley, crankshaft	2.0 FSI		<b>F8-5650</b>		
Mounting, axle beam	1.6, 1.9 TDI, 2.0 FSI, 2.0 TDI, 2.0 TDI 16V, 2.0 TFSI		<b>F8-6076</b>		d=12; L=90; D=69
Repair Set, axle beam	1.6, 1.9 TDI, 2.0 FSI, 2.0 TDI, 2.0 TDI 16V, 2.0 TFSI		<b>F8-6077</b>		H=90; D=69
Top Strut Mounting	1.6, 1.8 TFSI, 1.9 TDI, 2.0 FSI, 2.0 TDI, 2.0 TDI 16V, 2.0 TFSI		<b>F8-6284</b>		
Top Strut Mounting	1.6, 1.8 TFSI, 1.9 TDI, 2.0 FSI, 2.0 TDI, 2.0 TDI 16V, 2.0 TFSI		<b>F8-6348</b>		
Belt Pulley, crankshaft	1.9 TDI, 2.0 TDI 16V	Number of Ribs: 5; Parameter: 6PK	<b>F8-6396</b>		H=41.6; d=30; Mounting points diam.[mm]=7, 8.6; D=139.7
Control Arm-/Trailing Arm Bush	1.6, 1.9 TDI, 2.0 FSI, 2.0 TDI 16V	Aluminium	<b>F8-6424</b>		
Control Arm-/Trailing Arm Bush	1.6, 1.9 TDI, 2.0 FSI, 2.0 TDI 16V	Aluminium	<b>F8-6425</b>		

<b>F5-1004</b>	<b>F5-1044</b>	<b>F8-5633</b>	<b>F8-5650</b>	<b>F8-6076</b>	<b>F8-6077</b>	<b>F8-6284</b>
Ref.Nr.: 038903119T	Ref.Nr.: 06B903119B	Ref.Nr.: 1K0407182A	Ref.Nr.: 06A105243E	Ref.Nr.: 1J0501541D	Ref.Nr.: 1J0501541DS	Ref.Nr.: 6N0412249C
<b>F8-6348</b>	<b>F8-6392</b>	<b>F8-6396</b>	<b>F8-6424</b>	<b>F8-6425</b>	<b>F8-6463</b>	<b>F8-6464</b>
Ref.Nr.: 1K0513353G	Ref.Nr.: 038105243	Ref.Nr.: 03G105243	Ref.Nr.: 1K0199232G	Ref.Nr.: 1K0199231J	Ref.Nr.: 1K0505541B	Ref.Nr.: 8N0407181B
<b>F8-6579</b>	<b>F8-6960</b>	<b>F8-7133</b>	<b>F8-7864</b>	<b>F8-7978</b>	<b>G9-648</b>	<b>G9-649</b>
Ref.Nr.: 1J0 411 336 C	Ref.Nr.: 1J0199262P	Ref.Nr.: 1J0412319C	Ref.Nr.: 038 105 243	Ref.Nr.: 357407182F	Ref.Nr.: 357407182	Ref.Nr.: 1J0407181

Article Description

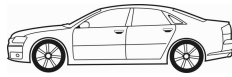

Article Nr.

Fitting Position



**TOLEDO III (5P2)**

04/2004 → 05/2009

Control Arm-/Trailing Arm Bush	1.6, 1.8 TFSI, 1.9 TDI, 2.0 FSI, 2.0 TDI, 2.0 TDI 16V, 2.0 TFSI		<b>F8-6463</b>		H=64; d=12; D=60
Engine Mounting	2.0 TDI	BMN	<b>F8-6528</b>		
Engine Mounting	2.0 TDI, 2.0 TDI 16V		<b>F8-6528</b>		
Anti-Friction Bearing	1.6, 1.8 TFSI, 1.9 TDI, 2.0 FSI, 2.0 TDI, 2.0 TDI 16V, 2.0 TFSI		<b>F8-6569</b>		
Top Strut Mounting	1.6, 1.8 TFSI, 1.9 TDI, 2.0 FSI, 2.0 TDI, 2.0 TDI 16V, 2.0 TFSI		<b>F8-6570</b>		
Engine Mounting	1.6		<b>F8-6988</b>		
Engine Mounting	2.0 FSI, 2.0 TFSI		<b>F8-6989</b>		
Rubber Buffer, suspension	1.6, 1.8 TFSI, 1.9 TDI, 2.0 FSI, 2.0 TDI, 2.0 TDI 16V, 2.0 TFSI	for OE: G39, G40, G52, G53, G54, G55	<b>F8-7131</b>		H=70
Protective Cap/Bellow, shock absorber	1.6, 1.8 TFSI, 1.9 TDI, 2.0 FSI, 2.0 TDI, 2.0 TDI 16V, 2.0 TFSI		<b>F8-7132</b>		H=190
Rubber Buffer, suspension	1.6, 1.8 TFSI, 1.9 TDI, 2.0 FSI, 2.0 TDI, 2.0 TDI 16V, 2.0 TFSI	for OE: 1JA, 1JC, 1JV, UC0, UC4, UG0, UG4; ,	<b>F8-7580</b>		H=101
Rubber Buffer, suspension	1.6, 1.8 TFSI, 1.9 TDI, 2.0 FSI, 2.0 TDI, 2.0 TDI 16V, 2.0 TFSI	for OE: UC2, UC3; Shape Round;	<b>F8-7601</b>		H=118
Protective Cap/Bellow, shock absorber	1.6, 1.8 TFSI, 1.9 TDI, 2.0 FSI, 2.0 TDI, 2.0 TDI 16V, 2.0 TFSI	for OE: 1JA, 1JC, 1JV, UC0, UC2, UC3, UC4; ,	<b>F8-7640</b>		H=176
Rubber Buffer, suspension	1.6, 1.8 TFSI, 1.9 TDI, 2.0 FSI, 2.0 TDI, 2.0 TDI 16V, 2.0 TFSI		<b>F8-7697</b>		H=55
Rubber Buffer, suspension	1.6, 1.8 TFSI, 1.9 TDI, 2.0 FSI, 2.0 TDI, 2.0 TDI 16V, 2.0 TFSI		<b>F8-7809</b>		H=55
Rubber Buffer, suspension	1.6, 1.8 TFSI, 1.9 TDI, 2.0 FSI, 2.0 TDI, 2.0 TDI 16V, 2.0 TFSI		<b>F8-7834</b>		H=90
Belt Pulley, crankshaft	1.8 TFSI	Number of Ribs: 5; Parameter: 6PK	<b>F8-7880</b>		D=143
Control Arm-/Trailing Arm Bush	1.6, 1.8 TFSI, 1.9 TDI, 2.0 FSI, 2.0 TDI, 2.0 TDI 16V, 2.0 TFSI		<b>F8-7902</b>		H=60; d=12; D=42
Control Arm-/Trailing Arm Bush	1.6, 1.8 TFSI, 1.9 TDI, 2.0 FSI, 2.0 TDI, 2.0 TDI 16V, 2.0 TFSI		<b>F8-7907</b>		H=45; d=14; D=38
Control Arm-/Trailing Arm Bush	1.6, 1.8 TFSI, 1.9 TDI, 2.0 FSI, 2.0 TDI, 2.0 TDI 16V, 2.0 TFSI		<b>F8-7908</b>		H=45; d=12; D=38
Control Arm-/Trailing Arm Bush	1.6, 1.8 TFSI, 1.9 TDI, 2.0 FSI, 2.0 TDI, 2.0 TDI 16V, 2.0 TFSI		<b>F8-7909</b>		
Stabiliser Mounting	1.6, 1.9 TDI, 2.0 FSI, 2.0 TDI 16V		<b>F8-7930</b>		d=18,5
Engine Mounting	1.9 TDI		<b>F8-7958</b>		
Engine Mounting	1.6		<b>F8-7960</b>		
Engine Mounting	1.8 TFSI	CDAA	<b>F8-7961</b>		
Engine Mounting	1.9 TDI	BLS, BXE;  6-speed	<b>F8-7961</b>		
Engine Mounting	2.0 FSI	6-speed	<b>F8-7961</b>		
Engine Mounting	2.0 TDI, 2.0 TDI 16V	Transmission Type: DSG	<b>F8-7962</b>		

<b>F8-6463</b>	<b>F8-6528</b>	<b>F8-6569</b>	<b>F8-6570</b>	<b>F8-6988</b>	<b>F8-6989</b>	<b>F8-7131</b>
Ref.Nr.: 1K0505541B	Ref.Nr.: 1K0 199 262 AT	Ref.Nr.: 6N0412249C	Ref.Nr.: 1K0412331C	Ref.Nr.: 1K0199262AL	Ref.Nr.: 1K0199262AM	Ref.Nr.: 1K0412303B
<b>F8-7132</b>	<b>F8-7580</b>	<b>F8-7601</b>	<b>F8-7640</b>	<b>F8-7697</b>	<b>F8-7809</b>	<b>F8-7834</b>
Ref.Nr.: 6N0413175A	Ref.Nr.: 1K0 511 353 Q	Ref.Nr.: 1K0511353N	Ref.Nr.: 1K0513425A	Ref.Nr.: 1K0412303F	Ref.Nr.: 1K0412303E	Ref.Nr.: 1K0412303H
<b>F8-7880</b>	<b>F8-7902</b>	<b>F8-7907</b>	<b>F8-7908</b>	<b>F8-7909</b>	<b>F8-7930</b>	<b>F8-7958</b>
Ref.Nr.: 06H105243F	Ref.Nr.: 1K0505171C	Ref.Nr.: 1K0505203A	Ref.Nr.: 1K0505279A	Ref.Nr.: 1K0505553 A	Ref.Nr.: 1K0511327AP	Ref.Nr.: 1K0199262AS

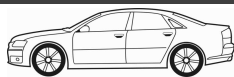
**Article Description****Article Nr.****Fitting Position**

<b>TOLEDO III (5P2)</b>				<b>04/2004 → 05/2009</b>	
Engine Mounting	2.0 TFSI	6-speed	<b>F8-7962</b>		
Engine Mounting	1.6		<b>F8-7965</b>		
Engine Mounting	1.9 TDI, 2.0 FSI, 2.0 TDI, 2.0 TDI 16V		<b>F8-7966</b>		
Engine Mounting	2.0 TDI	BMN	<b>F8-7966</b>		
Engine Mounting	1.6	BSE, BSF, CCSA	<b>F8-7982</b>		
Engine Mounting	1.8 TFSI	BZB	<b>F8-7982</b>		
Engine Mounting	1.9 TDI	BKC, BLS, BXE	<b>F8-7982</b>		
Engine Mounting	2.0 FSI, 2.0 TDI, 2.0 TDI 16V, 2.0 TFSI		<b>F8-7982</b>		
Engine Mounting	2.0 TDI, 2.0 TDI 16V	6-speed	<b>F8-8152</b>		
<b>TOLEDO IV (KG3)</b>				<b>07/2012 →</b>	
Dust Cover Kit, shock absorber	1.2, 1.2 TSI, 1.4 TSI, 1.6 TDI		<b>AK-735410</b>		H=210
Alternator Freewheel Clutch	1.6 TDI		<b>F5-1004</b>		
Alternator Freewheel Clutch	1.2 TSI, 1.4 TSI		<b>F5-1064</b>		
Anti-Friction Bearing	1.2, 1.2 TSI, 1.4 TSI, 1.6 TDI	for OE: G45, G46, G47, G48	<b>F8-3039</b>		H=14; d1=14; D=45
Top Strut Mounting	1.2, 1.2 TSI, 1.4 TSI, 1.6 TDI		<b>F8-4067</b>		H=53; d=26; D=82
Rubber Buffer, suspension	1.2, 1.2 TSI, 1.4 TSI, 1.6 TDI		<b>F8-5381</b>		H=37; D=76
Protective Cap/Bellow, shock absorber	1.2, 1.2 TSI, 1.4 TSI, 1.6 TDI		<b>F8-5683</b>		H=210
Rubber Buffer, suspension	1.2, 1.2 TSI, 1.4 TSI, 1.6 TDI	for OE: G47, G48	<b>F8-5993</b>		H=83
Rubber Buffer, suspension	1.2, 1.2 TSI, 1.4 TSI, 1.6 TDI	for OE: G45, G46	<b>F8-5996</b>		H=63
Protective Cap/Bellow, shock absorber	1.2, 1.2 TSI, 1.4 TSI, 1.6, 1.6 TDI	for OE: 1JA;	<b>F8-6044</b>		H=160
Protective Cap/Bellow, shock absorber	1.2, 1.2 TSI, 1.4 TSI, 1.6, 1.6 TDI	for OE: 1JB;	<b>F8-6044</b>		H=160
Top Strut Mounting	1.2, 1.2 TSI, 1.4 TSI, 1.6 TDI		<b>F8-6280</b>		H=53; d=26; D=82
Top Strut Mounting	1.2, 1.2 TSI, 1.4 TSI, 1.6 TDI	for OE: 1J0412319C	<b>F8-7133</b>		

<b>AK-735410</b>	<b>F5-1004</b>	<b>F5-1064</b>	<b>F8-3039</b>	<b>F8-4067</b>	<b>F8-5381</b>	<b>F8-5683</b>
Ref.Nr.: 1J0412303	Ref.Nr.: 038903119T	Ref.Nr.: 03C903119D	Ref.Nr.: 357412249A	Ref.Nr.: 1J0412331B	Ref.Nr.: 1J0512149B	Ref.Nr.: 357413175A
<b>F8-5993</b>	<b>F8-5996</b>	<b>F8-6044</b>	<b>F8-6280</b>	<b>F8-7133</b>	<b>F8-7962</b>	<b>F8-7965</b>
Ref.Nr.: 357412303F	Ref.Nr.: 1H0412303B	Ref.Nr.: 3C0513425	Ref.Nr.: 6R0412249	Ref.Nr.: 1J0412319C	Ref.Nr.: 1K0199555Q	Ref.Nr.: 1K0199855BA
<b>F8-7966</b>	<b>F8-7982</b>	<b>F8-8152</b>				
Ref.Nr.: 1K0199855BB	Ref.Nr.: 1K0199868Q	Ref.Nr.: 1K0199555T				

Article Description



Article Nr.

Fitting Position



<b>CITIGO</b>			<b>10/2011 →</b>		
Dust Cover Kit, shock absorber	1.0	<b>ST</b>	<b>AK-735410</b>		H=210
Alternator Freewheel Clutch	All Models		<b>F5-1064</b>		
Anti-Friction Bearing	All Models		<b>F8-3039</b>		H=14; d1=14; D=45
Top Strut Mounting	All Models		<b>F8-4067</b>		H=53; d=26; D=82
Rubber Buffer, suspension	All Models		<b>F8-5381</b>		H=37; D=76
Protective Cap/Bellow, shock absorber	1.0		<b>F8-5683</b>		H=210
Top Strut Mounting	All Models		<b>F8-6280</b>		H=53; d=26; D=82
Rubber Buffer, suspension	1.0		<b>F8-6723</b>		H=124
Top Strut Mounting	1.0	for OE: 1J0412319C	<b>F8-7133</b>		
Protective Cap/Bellow, shock absorber	All Models		<b>F8-7486</b>		
Rubber Buffer, suspension	All Models	for OE: G01, G02, G06; <b>ST</b> ; for vehicles with gas operation	<b>F8-7891</b>		H=63
Rubber Buffer, suspension	All Models	for OE: G03; <b>SP</b>	<b>F8-7892</b>		H=53
Rubber Buffer, suspension	All Models	for OE: 1JC; <b>SP</b>	<b>F8-7893</b>		H=122
Control Arm-/Trailing Arm Bush	1.0		<b>F8-7978</b>		
<b>FABIA (6Y2)</b>			<b>08/1999 → 03/2008</b>		
Dust Cover Kit, shock absorber	All Models		<b>AK-735004</b>		
Dust Cover Kit, shock absorber	All Models		<b>AK-735266</b>		
Dust Cover Kit, shock absorber	All Models		<b>AK-735409</b>		
Alternator Freewheel Clutch	1.2		<b>F5-1000</b>		
Alternator Freewheel Clutch	1.4 TDI, 1.9 SDI, 1.9 TDI, 1.9 TDI RS		<b>F5-1004</b>		
Alternator Freewheel Clutch	1.4 TDI		<b>F5-1085</b>		
Top Strut Mounting	All Models		<b>F8-5380</b>		
Rubber Buffer, suspension	All Models		<b>F8-5381</b>		H=37; D=76
Engine Mounting	1.0	A QV, ARV;	<b>F8-5532</b>		
Engine Mounting	1.4		<b>F8-5532</b>		
Engine Mounting	1.4 16V		<b>F8-5532</b>		
Engine Mounting	2.0		<b>F8-5533</b>		
Engine Mounting	1.4 16V		<b>F8-5534</b>		
Engine Mounting	1.9 TDI		<b>F8-5535</b>		
Top Strut Mounting	1.0, 1.2, 1.4, 1.4 16V, 1.4 TDI, 1.9 SDI, 1.9 TDI, 1.9 TDI RS, 2.0	ch.→6Y-2-345000, 6Y-SX022801;	<b>F8-5537</b>		
Top Strut Mounting	1.0, 1.2, 1.4, 1.4 16V, 1.4 TDI, 1.9 SDI, 1.9 TDI, 1.9 TDI RS, 2.0	ch.6Y-2-345001, 6Y-SX022802→; for OE: G01, G02, G05; ; <b>ST</b>	<b>F8-5537</b>		

<b>AK-735004</b>	<b>AK-735266</b>	<b>AK-735409</b>	<b>AK-735410</b>	<b>F5-1000</b>	<b>F5-1004</b>	<b>F5-1064</b>
Ref.Nr.:	Ref.Nr.: 1J0513425	Ref.Nr.: 1J0513425	Ref.Nr.: 1J0412303	Ref.Nr.: 03D903119A	Ref.Nr.: 038903119T	Ref.Nr.: 03C903119D
<b>F5-1085</b>	<b>F8-3039</b>	<b>F8-4067</b>	<b>F8-5380</b>	<b>F8-5381</b>	<b>F8-5532</b>	<b>F8-5533</b>
Ref.Nr.: 045903119A	Ref.Nr.: 357412249A	Ref.Nr.: 1J0412331B	Ref.Nr.: 1J0513353G	Ref.Nr.: 1J0512149B	Ref.Nr.: 6Q0199851S	Ref.Nr.: 6Q0199851M
<b>F8-5534</b>	<b>F8-5535</b>	<b>F8-5537</b>	<b>F8-5683</b>	<b>F8-6280</b>	<b>F8-6723</b>	<b>F8-7133</b>
Ref.Nr.: 6Q0199851AB	Ref.Nr.: 6Q0199167BQ	Ref.Nr.: 6N0412331E	Ref.Nr.: 357413175A	Ref.Nr.: 6R0412249	Ref.Nr.: 6Q0512131B	Ref.Nr.: 1J0412319C



**Article Description****Article Nr.****Fitting Position**

<b>FABIA (6Y2)</b>			<b>08/1999 → 03/2008</b>	
Top Strut Mounting	1.4 TDI	for OE: G01, G02, G05; ;	<b>F8-5537</b>	
Engine Mounting	1.4 16V		<b>F8-5551</b>	
Belt Pulley, crankshaft	2.0		<b>F8-5650</b>	
Rubber Buffer, suspension	1.0, 1.4		<b>F8-6002</b>	H=120
Rubber Buffer, suspension	1.2, 1.4, 1.4 16V, 1.4 TDI, 1.9 SDI, 1.9 TDI, 2.0	ch.→6Y-1-160000, 6Y-1X012500	<b>F8-6002</b>	H=120
Protective Cap/Bellow, shock absorber	All Models		<b>F8-6044</b>	H=160
Mounting, axle beam	All Models		<b>F8-6076</b>	d=12; L=90; D=69
Repair Set, axle beam	All Models		<b>F8-6077</b>	H=90; D=69
Top Strut Mounting	1.0, 1.2, 1.4, 1.4 16V, 1.4 TDI, 1.9 SDI, 1.9 TDI, 1.9 TDI RS, 2.0	ch.→6Y-2-345000, 6Y-SX022801;	<b>F8-6281</b>	
Top Strut Mounting	1.0, 1.2, 1.4, 1.4 16V, 1.4 TDI, 1.9 SDI, 1.9 TDI, 1.9 TDI RS, 2.0	ch.6Y-2-345001, 6Y-SX022802→; for OE: G01, G02, G05; ;	<b>F8-6281</b>	
Top Strut Mounting	1.4 TDI	for OE: G01, G02, G05; ;	<b>F8-6281</b>	
Belt Pulley, crankshaft	1.9 TDI, 1.9 TDI RS	Number of Ribs: 5; Parameter: 6PK	<b>F8-6396</b>	
Stabiliser Mounting	All Models	ch.6Y-3-651671→	<b>F8-6460</b>	d=18
Stabiliser Mounting	1.2, 1.4, 1.4 16V, 1.4 TDI, 1.9 SDI, 1.9 TDI, 1.9 TDI RS, 2.0		<b>F8-6461</b>	d=17
Stabiliser Mounting	All Models	Stabi. Diam. [mm]= 18	<b>F8-6462</b>	d=16
Engine Mounting	1.2		<b>F8-6532</b>	
Engine Mounting	1.2	AZQ	<b>F8-6532</b>	
Engine Mounting	1.4 TDI		<b>F8-6533</b>	
Anti-Friction Bearing	All Models		<b>F8-6569</b>	
Belt Pulley, crankshaft	1.9 SDI	ch.6Y-3-849645→; Number of Ribs: 5; Parameter: 6PK	<b>F8-6572</b>	
Stabiliser Mounting	1.0, 1.2, 1.4, 1.4 16V, 1.4 TDI, 1.9 SDI, 1.9 TDI, 1.9 TDI RS, 2.0	ch.→6Y-3-651670	<b>F8-6694</b>	d=19.8
Rubber Buffer, suspension	1.0, 1.4, 1.4 TDI, 1.9 TDI RS	ch.6Y11X012501→	<b>F8-6723</b>	H=124
Rubber Buffer, suspension	1.2, 1.4, 1.4 16V, 1.4 TDI, 1.9 SDI, 1.9 TDI, 2.0	ch.6Y-1-160001, 6Y-1X012501→	<b>F8-6723</b>	H=124
Control Arm-/Trailing Arm Bush	All Models		<b>F8-6736</b>	
Engine Mounting	1.4 16V		<b>F8-6752</b>	
Engine Mounting	1.9 TDI RS		<b>F8-6945</b>	
Protective Cap/Bellow, shock absorber	All Models		<b>F8-7132</b>	H=190
Rubber Buffer, suspension	All Models	for OE: 1GB, G03, G06;	<b>F8-7675</b>	H=84
Rubber Buffer, suspension	All Models	for OE: G04;	<b>F8-7676</b>	H=56
Rubber Buffer, suspension	All Models	for OE: 1GA, 1GG, G01, G02, G05;	<b>F8-7830</b>	

<b>F8-5537</b>	<b>F8-5551</b>	<b>F8-5650</b>	<b>F8-6002</b>	<b>F8-6044</b>	<b>F8-6076</b>	<b>F8-6077</b>
Ref.Nr.: 6N0412331E	Ref.Nr.: 6Q0199167BM	Ref.Nr.: 06A105243E	Ref.Nr.: 6X0512131A	Ref.Nr.: 3C0513425	Ref.Nr.: 1J0501541D	Ref.Nr.: 1J0501541DS
<b>F8-6281</b>	<b>F8-6396</b>	<b>F8-6460</b>	<b>F8-6461</b>	<b>F8-6462</b>	<b>F8-6532</b>	<b>F8-6533</b>
Ref.Nr.: 8Z0412331	Ref.Nr.: 03G105243	Ref.Nr.: 6Q0411314R	Ref.Nr.: 6Q0 411 314 M	Ref.Nr.: 6Q0411314L	Ref.Nr.: 6Q0 199 167 BC	Ref.Nr.: 6Q0 199 167 CA
<b>F8-6569</b>	<b>F8-6572</b>	<b>F8-6694</b>	<b>F8-6723</b>	<b>F8-6736</b>	<b>F8-6752</b>	<b>F8-6945</b>
Ref.Nr.: 6N0412249C	Ref.Nr.: 038105243L	Ref.Nr.: 6Q0411314F	Ref.Nr.: 6Q0512131B	Ref.Nr.: 1K0407183A	Ref.Nr.: 6Q0199167BN	Ref.Nr.: 6Q0199167CS

Article Description



Article Nr.

Fitting Position



<b>FABIA (6Y2)</b>			<b>08/1999 → 03/2008</b>		
Control Arm-/Trailing Arm Bush	All Models		F8-7873		
Stabiliser Mounting	1.0, 1.2, 1.4, 1.4 16V, 1.9 SDI, 1.9 TDI, 2.0	ch.→6Y-3-651670	F8-7914		d=20,8
Mounting, axle beam	All Models	for OE: 0N7; <b>HD</b>	F8-7928		
Engine Mounting	1.4 16V		F8-7949		
Engine Mounting	1.4 TDI		F8-7950		
Engine Mounting	1.0, 1.2, 1.4, 1.4 16V		F8-7951		
Engine Mounting	1.4 TDI		F8-7952		
Engine Mounting	1.0, 1.4		F8-7954		
Engine Mounting	1.4 16V		F8-7954		
Engine Mounting	1.2		F8-7955		
Engine Mounting	1.9 TDI		F8-7956		
Belt Pulley, crankshaft	1.4 TDI	Number of Ribs: 5; Parameter: 6PK	F8-8038		
Engine Mounting	1.4 16V, 1.4 TDI, 1.9 SDI, 2.0		F8-8164		
Engine Mounting	1.9 TDI		F8-8173		
<b>FABIA Combi (6Y5)</b>			<b>04/2000 → 12/2007</b>		
Dust Cover Kit, shock absorber	All Models		AK-735004		
Dust Cover Kit, shock absorber	All Models		AK-735266		
Dust Cover Kit, shock absorber	All Models		AK-735409		
Alternator Freewheel Clutch	1.2		F5-1000		
Alternator Freewheel Clutch	1.4 TDI, 1.9 SDI, 1.9 TDI		F5-1004		
Alternator Freewheel Clutch	1.4 TDI		F5-1085		
Top Strut Mounting	All Models		F8-5380		
Rubber Buffer, suspension	1.0, 1.2, 1.4, 1.4 16V, 1.4 TDI, 1.9 SDI, 1.9 TDI, 2.0		F8-5381		H=37; D=76
Engine Mounting	1.4		F8-5532		
Engine Mounting	1.4 16V		F8-5532		
Engine Mounting	2.0		F8-5533		
Engine Mounting	1.4 16V		F8-5534		
Engine Mounting	1.9 TDI		F8-5535		
Top Strut Mounting	1.0, 1.2, 1.4, 1.4 16V, 1.4 TDI, 1.9 SDI, 1.9 TDI, 2.0	ch.→6Y-2-345000, 6Y-SX022801;	F8-5537		
Top Strut Mounting	1.0, 1.2, 1.4, 1.4 16V, 1.4 TDI, 1.9 SDI, 1.9 TDI, 2.0	ch.6Y-2-345001, 6Y-SX022802→; for OE: G01, G02, G05; ; <b>ST</b>	F8-5537		
Top Strut Mounting	1.4 16V, 1.4 TDI	for OE: G01, G02, G05; ; <b>ST</b>	F8-5537		
Engine Mounting	1.4 16V		F8-5551		
Belt Pulley, crankshaft	2.0		F8-5650		
Rubber Buffer, suspension	1.2, 1.4, 1.4 16V, 1.9 SDI, 1.9 TDI, 2.0		F8-6002		H=120

<b>AK-735004</b>	<b>AK-735266</b>	<b>AK-735409</b>	<b>F5-1000</b>	<b>F5-1004</b>	<b>F5-1085</b>	<b>F8-5380</b>
Ref.Nr.:	Ref.Nr.: 1J0513425	Ref.Nr.: 1J0513425	Ref.Nr.: 03D903119A	Ref.Nr.: 038903119T	Ref.Nr.: 045903119A	Ref.Nr.: 1J0513353G
<b>F8-5381</b>	<b>F8-5532</b>	<b>F8-5533</b>	<b>F8-5534</b>	<b>F8-5535</b>	<b>F8-5537</b>	<b>F8-5551</b>
Ref.Nr.: 1J0512149B	Ref.Nr.: 6Q0199851S	Ref.Nr.: 6Q0199851M	Ref.Nr.: 6Q0199851AB	Ref.Nr.: 6Q0199167BQ	Ref.Nr.: 6N0412331E	Ref.Nr.: 6Q0199167BM
<b>F8-5650</b>	<b>F8-6002</b>	<b>F8-6044</b>	<b>F8-7873</b>	<b>F8-7914</b>	<b>F8-7928</b>	<b>F8-7949</b>
Ref.Nr.: 06A105243E	Ref.Nr.: 6X0512131A	Ref.Nr.: 3C0513425	Ref.Nr.: 6Q0407182A	Ref.Nr.: 8Z0411314B	Ref.Nr.: 6Q0501541E	Ref.Nr.: 6Q0199851AK

**Article Description****Article Nr.****Fitting Position**

<b>FABIA Combi (6Y5)</b>			<b>04/2000 → 12/2007</b>		
Protective Cap/Bellow, shock absorber	1.0, 1.2, 1.4, 1.4 16V, 1.4 TDI, 1.9 SDI, 1.9 TDI, 2.0		<b>F8-6044</b>		H=160
Mounting, axle beam	1.2, 1.4, 1.4 16V, 1.9 SDI, 1.9 TDI, 2.0		<b>F8-6076</b>		d=12; L=90; D=69
Repair Set, axle beam	1.2	AWY	<b>F8-6077</b>		H=90; D=69
Repair Set, axle beam	1.4 16V	AUA	<b>F8-6077</b>		H=90; D=69
Repair Set, axle beam	1.4, 1.4 16V, 1.9 SDI, 2.0		<b>F8-6077</b>		H=90; D=69
Repair Set, axle beam	1.9 TDI	ATD	<b>F8-6077</b>		H=90; D=69
Top Strut Mounting	1.0, 1.2, 1.4, 1.4 16V, 1.4 TDI, 1.9 SDI, 1.9 TDI, 2.0	ch.→6Y-2-345000, 6Y-SX022801;	<b>F8-6281</b>		
Top Strut Mounting	1.0, 1.2, 1.4, 1.4 16V, 1.4 TDI, 1.9 SDI, 1.9 TDI, 2.0	ch.6Y-2-345001, 6Y-SX022802→; for OE: G01, G02, G05;	<b>F8-6281</b>		
Top Strut Mounting	1.4 16V, 1.4 TDI	for OE: G01, G02, G05;	<b>F8-6281</b>		
Belt Pulley, crankshaft	1.9 TDI	Number of Ribs: 5; Parameter: 6PK	<b>F8-6396</b>		H=41.6; d=30; Mounting points diam.[mm]=7, 8.6; D=139.7
Stabiliser Mounting	1.0, 1.2, 1.4, 1.4 16V, 1.4 TDI, 1.9 SDI, 1.9 TDI, 2.0	ch.6Y-3-651671→	<b>F8-6460</b>		d=18
Stabiliser Mounting	1.2, 1.4, 1.4 16V, 1.4 TDI, 1.9 SDI, 1.9 TDI, 2.0		<b>F8-6461</b>		d=17
Stabiliser Mounting	1.0, 1.2, 1.4, 1.4 16V, 1.4 TDI, 1.9 SDI, 1.9 TDI, 2.0	Stabi. Diam. [mm]= 18	<b>F8-6462</b>		d=16
Engine Mounting	1.2		<b>F8-6532</b>		
Engine Mounting	1.2	AZQ	<b>F8-6532</b>		
Engine Mounting	1.4 TDI		<b>F8-6533</b>		
Anti-Friction Bearing	All Models		<b>F8-6569</b>		
Belt Pulley, crankshaft	1.9 SDI	ch.6Y-3-849645→; Number of Ribs: 5; Parameter: 6PK	<b>F8-6572</b>		
Stabiliser Mounting	1.0, 1.2, 1.4, 1.4 16V, 1.4 TDI, 1.9 SDI, 1.9 TDI, 2.0	ch.→6Y-3-651670	<b>F8-6694</b>		d=19.8
Rubber Buffer, suspension	All Models	ch.6Y11X012501→	<b>F8-6723</b>		H=124
Control Arm-/Trailing Arm Bush	1.2, 1.4, 1.4 16V, 1.4 TDI, 1.9 SDI, 1.9 TDI, 2.0		<b>F8-6736</b>		
Engine Mounting	1.4 16V		<b>F8-6752</b>		
Protective Cap/Bellow, shock absorber	All Models		<b>F8-7132</b>		H=190
Rubber Buffer, suspension	All Models	for OE: 1GB, G03, G06;	<b>F8-7675</b>		H=84
Rubber Buffer, suspension	All Models	for OE: G04;	<b>F8-7676</b>		H=56
Rubber Buffer, suspension	All Models	for OE: 1GA, 1GG, G01, G02, G05;	<b>F8-7830</b>		
Control Arm-/Trailing Arm Bush	All Models		<b>F8-7873</b>		
Stabiliser Mounting	1.2, 1.4, 1.4 16V, 1.9 SDI, 1.9 TDI, 2.0	ch.→6Y-3-651670	<b>F8-7914</b>		d=20.8
Mounting, axle beam	All Models	for OE: 0N7;	<b>F8-7928</b>		
Engine Mounting	1.4 16V		<b>F8-7949</b>		
Engine Mounting	1.4 TDI		<b>F8-7950</b>		

<b>F8-6044</b>	<b>F8-6076</b>	<b>F8-6077</b>	<b>F8-6281</b>	<b>F8-6396</b>	<b>F8-6460</b>	<b>F8-6461</b>
Ref.Nr.: 3C0513425	Ref.Nr.: 1J0501541D	Ref.Nr.: 1J0501541DS	Ref.Nr.: 8Z0412331	Ref.Nr.: 03G105243	Ref.Nr.: 6Q0411314R	Ref.Nr.: 6Q0 411 314 M
<b>F8-6462</b>	<b>F8-6532</b>	<b>F8-6533</b>	<b>F8-6569</b>	<b>F8-6572</b>	<b>F8-6694</b>	<b>F8-6723</b>
Ref.Nr.: 6Q0411314L	Ref.Nr.: 6Q0 199 167 BC	Ref.Nr.: 6Q0 199 167 CA	Ref.Nr.: 6N0412249C	Ref.Nr.: 038105243L	Ref.Nr.: 6Q0411314F	Ref.Nr.: 6Q0512131B
<b>F8-6736</b>	<b>F8-6752</b>	<b>F8-7132</b>	<b>F8-7675</b>	<b>F8-7676</b>	<b>F8-7830</b>	<b>F8-7873</b>
Ref.Nr.: 1K0407183A	Ref.Nr.: 6Q0199167BN	Ref.Nr.: 6N0413175A	Ref.Nr.: 6Q0412301	Ref.Nr.: 6Q0412301A	Ref.Nr.: 6N0412303A	Ref.Nr.: 6Q0407182A

Article Description



Article Nr.

Fitting Position



<b>FABIA Combi (6Y5)</b>			04/2000 → 12/2007		
Engine Mounting	1.2, 1.4, 1.4 16V		F8-7951		
Engine Mounting	1.4 TDI		F8-7952		
Engine Mounting	1.0, 1.4		F8-7954		
Engine Mounting	1.4 16V		F8-7954		
Engine Mounting	1.2		F8-7955		
Engine Mounting	1.9 TDI		F8-7956		
Belt Pulley, crankshaft	1.4 TDI	Number of Ribs: 5; Parameter: 6PK	F8-8038		
Engine Mounting	1.4 16V, 1.4 TDI, 1.9 SDI, 2.0		F8-8164		
Engine Mounting	1.9 TDI		F8-8173		
<b>FABIA Praktik</b>			07/2001 → 12/2007		
Dust Cover Kit, shock absorber	All Models		AK-735266		
Alternator Freewheel Clutch	1.2		F5-1000		
Alternator Freewheel Clutch	1.4 TDI, 1.9 SDI		F5-1004		
Alternator Freewheel Clutch	1.4 TDI		F5-1085		
Top Strut Mounting	All Models		F8-5380		
Rubber Buffer, suspension	All Models		F8-5381		H=37; D=76
Top Strut Mounting	1.2, 1.4, 1.9 SDI	ch.→6Y-2-345000, 6Y-SX022801;	F8-5537		
Top Strut Mounting	1.2, 1.4, 1.9 SDI	ch.6Y-2-345001, 6Y-SX022802→; for OE: G01, G02, G05;	F8-5537		
Top Strut Mounting	1.4 TDI	for OE: G01, G02, G05;	F8-5537		
Top Strut Mounting	1.2, 1.4, 1.9 SDI	ch.→6Y-2-345000, 6Y-SX022801;	F8-6281		
Top Strut Mounting	1.2, 1.4, 1.9 SDI	ch.6Y-2-345001, 6Y-SX022802→; for OE: G01, G02, G05;	F8-6281		
Top Strut Mounting	1.4 TDI	for OE: G01, G02, G05;	F8-6281		
Stabiliser Mounting	1.2, 1.4 TDI	ch.6Y-3-651671→	F8-6460		d=18
Stabiliser Mounting	All Models		F8-6461		d=17
Stabiliser Mounting	1.2, 1.4 TDI	Stabi. Diam. [mm]= 18	F8-6462		d=16
Engine Mounting	1.2		F8-6532		
Anti-Friction Bearing	All Models		F8-6569		
Belt Pulley, crankshaft	1.9 SDI	Number of Ribs: 5; Parameter: 6PK	F8-6572		
Stabiliser Mounting	1.4, 1.9 SDI	ch.→6Y-3-651670	F8-6694		d=19.8
Rubber Buffer, suspension	All Models		F8-6723		H=124
Control Arm-/Trailing Arm Bush	All Models		F8-6736		
Protective Cap/Bellow, shock absorber	All Models		F8-7132		H=190

<b>AK-735266</b>	<b>F5-1000</b>	<b>F5-1004</b>	<b>F5-1085</b>	<b>F8-5380</b>	<b>F8-5381</b>	<b>F8-5537</b>
Ref.Nr.: 1J0513425	Ref.Nr.: 03D903119A	Ref.Nr.: 038903119T	Ref.Nr.: 045903119A	Ref.Nr.: 1J0513353G	Ref.Nr.: 1J0512149B	Ref.Nr.: 6N0412331E
<b>F8-6281</b>	<b>F8-6460</b>	<b>F8-6461</b>	<b>F8-6462</b>	<b>F8-6532</b>	<b>F8-6569</b>	<b>F8-6572</b>
Ref.Nr.: 8Z0412331	Ref.Nr.: 6Q0411314R	Ref.Nr.: 6Q0 411 314 M	Ref.Nr.: 6Q0411314L	Ref.Nr.: 6Q0 199 167 BC	Ref.Nr.: 6N0412249C	Ref.Nr.: 038105243L
<b>F8-6694</b>	<b>F8-6723</b>	<b>F8-6736</b>	<b>F8-7132</b>	<b>F8-7675</b>	<b>F8-7951</b>	<b>F8-7952</b>
Ref.Nr.: 6Q0411314F	Ref.Nr.: 6Q0512131B	Ref.Nr.: 1K0407183A	Ref.Nr.: 6N0413175A	Ref.Nr.: 6Q0412301	Ref.Nr.: 6Q0199555AR	Ref.Nr.: 6Q0199167DH

**Article Description****Article Nr.****Fitting Position**

<b>FABIA Praktik</b>			<b>07/2001 → 12/2007</b>		
Rubber Buffer, suspension	All Models	for OE: 1GB, G03, G06;	<b>F8-7675</b>		H=84
Rubber Buffer, suspension	All Models	for OE: G04;	<b>F8-7676</b>		H=56
Rubber Buffer, suspension	All Models	for OE: 1GA, 1GG, G01, G02, G05;	<b>F8-7830</b>		
Control Arm-/Trailing Arm Bush	All Models		<b>F8-7873</b>		
Stabiliser Mounting	1.4, 1.9 SDI	ch.→6Y-3-651670	<b>F8-7914</b>		d=20,8
Mounting, axle beam	All Models	for OE: 0N7;	<b>F8-7928</b>		
Engine Mounting	1.4 TDI		<b>F8-7950</b>		
Engine Mounting	1.2		<b>F8-7951</b>		
Engine Mounting	1.4		<b>F8-7954</b>		
Engine Mounting	1.4 TDI, 1.9 SDI		<b>F8-8164</b>		
<b>FABIA Saloon (6Y3)</b>			<b>10/1999 → 12/2007</b>		
Dust Cover Kit, shock absorber	All Models		<b>AK-735004</b>		
Dust Cover Kit, shock absorber	All Models		<b>AK-735266</b>		
Alternator Freewheel Clutch	1.2		<b>F5-1000</b>		
Alternator Freewheel Clutch	1.4 TDI, 1.9 SDI, 1.9 TDI		<b>F5-1004</b>		
Alternator Freewheel Clutch	1.4 TDI		<b>F5-1085</b>		
Top Strut Mounting	All Models		<b>F8-5380</b>		
Rubber Buffer, suspension	1.0, 1.2, 1.4, 1.4 16V, 1.4 TDI, 1.9 SDI, 1.9 TDI, 2.0		<b>F8-5381</b>		H=37; D=76
Engine Mounting	1.4		<b>F8-5532</b>		
Engine Mounting	1.4 16V		<b>F8-5532</b>		
Engine Mounting	2.0		<b>F8-5533</b>		
Engine Mounting	1.4 16V		<b>F8-5534</b>		
Engine Mounting	1.9 TDI		<b>F8-5535</b>		
Top Strut Mounting	1.0, 1.2, 1.4, 1.4 16V, 1.4 TDI, 1.9 SDI, 1.9 TDI, 2.0	ch.→6Y-2-345000, 6Y-SX022801;	<b>F8-5537</b>		
Top Strut Mounting	1.0, 1.2, 1.4, 1.4 16V, 1.4 TDI, 1.9 SDI, 1.9 TDI, 2.0	ch.6Y-2-345001, 6Y-SX022802→; for OE: G01, G02, G05; ;	<b>F8-5537</b>		
Top Strut Mounting	1.4 16V, 1.4 TDI	for OE: G01, G02, G05; ;	<b>F8-5537</b>		
Engine Mounting	1.4 16V		<b>F8-5551</b>		
Belt Pulley, crankshaft	2.0		<b>F8-5650</b>		
Rubber Buffer, suspension	1.0, 1.2, 1.4, 1.4 16V, 1.9 SDI, 1.9 TDI, 2.0		<b>F8-6002</b>		H=120
Protective Cap/Bellow, shock absorber	All Models		<b>F8-6044</b>		H=160
Mounting, axle beam	1.0, 1.2, 1.4, 1.4 16V, 1.4 TDI, 1.9 SDI, 1.9 TDI, 2.0		<b>F8-6076</b>		d=12; L=90; D=69
Repair Set, axle beam	1.0, 1.2, 1.4, 1.4 16V, 1.4 TDI, 1.9 SDI, 1.9 TDI, 2.0		<b>F8-6077</b>		H=90; D=69
Top Strut Mounting	1.0, 1.2, 1.4, 1.4 16V, 1.4 TDI, 1.9 SDI, 1.9 TDI, 2.0	ch.→6Y-2-345000, 6Y-SX022801;	<b>F8-6281</b>		

<b>AK-735004</b>	<b>AK-735266</b>	<b>F5-1000</b>	<b>F5-1004</b>	<b>F5-1085</b>	<b>F8-5380</b>	<b>F8-5381</b>
Ref.Nr.:	Ref.Nr.: 1J0513425	Ref.Nr.: 03D903119A	Ref.Nr.: 038903119T	Ref.Nr.: 045903119A	Ref.Nr.: 1J0513353G	Ref.Nr.: 1J0512149B
<b>F8-5532</b>	<b>F8-5533</b>	<b>F8-5534</b>	<b>F8-5535</b>	<b>F8-5537</b>	<b>F8-5551</b>	<b>F8-5650</b>
Ref.Nr.: 6Q0199851S	Ref.Nr.: 6Q0199851M	Ref.Nr.: 6Q0199851AB	Ref.Nr.: 6Q0199167BQ	Ref.Nr.: 6N0412331E	Ref.Nr.: 6Q0199167BM	Ref.Nr.: 06A105243E
<b>F8-6002</b>	<b>F8-6044</b>	<b>F8-6076</b>	<b>F8-6077</b>	<b>F8-6281</b>	<b>F8-7675</b>	<b>F8-7676</b>
Ref.Nr.: 6X0512131A	Ref.Nr.: 3C0513425	Ref.Nr.: 1J0501541D	Ref.Nr.: 1J0501541DS	Ref.Nr.: 8Z0412331	Ref.Nr.: 6Q0412301	Ref.Nr.: 6Q0412301A

Article Description



Article Nr.

Fitting Position



<b>FABIA Saloon (6Y3)</b>			<b>10/1999 → 12/2007</b>	
Top Strut Mounting	1.0, 1.2, 1.4, 1.4 16V, 1.4 TDI, 1.9 SDI, 1.9 TDI, 2.0	ch.6Y-2-345001, 6Y-SX022802→; for OE: G01, G02, G05;	<b>F8-6281</b>	
Top Strut Mounting	1.4 16V, 1.4 TDI	for OE: G01, G02, G05;	<b>F8-6281</b>	
Belt Pulley, crankshaft	1.9 TDI	Number of Ribs: 5; Parameter: 6PK	<b>F8-6396</b>	H=41.6; d=30; Mounting points diam.[mm]=7, 8.6; D=139.7
Stabiliser Mounting	All Models	ch.6Y-3-651671→	<b>F8-6460</b>	d=18
Stabiliser Mounting	1.2, 1.4, 1.4 16V, 1.4 TDI, 1.9 SDI, 1.9 TDI, 2.0		<b>F8-6461</b>	d=17
Stabiliser Mounting	All Models	Stabi. Diam. [mm]= 18	<b>F8-6462</b>	d=16
Engine Mounting	1.2		<b>F8-6532</b>	
Engine Mounting	1.4 TDI		<b>F8-6533</b>	
Anti-Friction Bearing	1.2, 1.4, 1.4 16V, 1.4 TDI, 1.9 SDI, 1.9 TDI, 2.0		<b>F8-6569</b>	
Belt Pulley, crankshaft	1.9 SDI	ch.6Y-3-849645→; Number of Ribs: 5; Parameter: 6PK	<b>F8-6572</b>	
Stabiliser Mounting	1.0, 1.2, 1.4, 1.4 16V, 1.4 TDI, 1.9 SDI, 1.9 TDI, 2.0	ch.→6Y-3-651670	<b>F8-6694</b>	d=19.8
Rubber Buffer, suspension	All Models	ch.6Y11X012501→	<b>F8-6723</b>	H=124
Control Arm-/Trailing Arm Bush	1.2, 1.4, 1.4 16V, 1.4 TDI, 1.9 SDI, 1.9 TDI, 2.0		<b>F8-6736</b>	
Engine Mounting	1.4 16V		<b>F8-6752</b>	
Protective Cap/Bellow, shock absorber	All Models		<b>F8-7132</b>	H=190
Rubber Buffer, suspension	All Models	for OE: 1GB, G03, G06;	<b>F8-7675</b>	H=84
Rubber Buffer, suspension	All Models	for OE: G04;	<b>F8-7676</b>	H=56
Rubber Buffer, suspension	All Models	for OE: 1GA, 1GG, G01, G02, G05;	<b>F8-7830</b>	
Control Arm-/Trailing Arm Bush	All Models		<b>F8-7873</b>	
Stabiliser Mounting	1.2, 1.4, 1.4 16V, 1.9 SDI, 1.9 TDI, 2.0	ch.→6Y-3-651670	<b>F8-7914</b>	d=20,8
Mounting, axle beam	All Models	for OE: 0N7;	<b>F8-7928</b>	
Engine Mounting	1.4 16V		<b>F8-7949</b>	
Engine Mounting	1.4 TDI		<b>F8-7950</b>	
Engine Mounting	1.0, 1.2, 1.4, 1.4 16V		<b>F8-7951</b>	
Engine Mounting	1.4 TDI		<b>F8-7952</b>	
Engine Mounting	1.0, 1.4		<b>F8-7954</b>	
Engine Mounting	1.4	AME	<b>F8-7954</b>	
Engine Mounting	1.4	AQW	<b>F8-7954</b>	
Engine Mounting	1.4 16V		<b>F8-7954</b>	
Engine Mounting	1.9 TDI		<b>F8-7956</b>	
Belt Pulley, crankshaft	1.4 TDI	Number of Ribs: 5; Parameter: 6PK	<b>F8-8038</b>	
Engine Mounting	1.4 16V, 1.4 TDI, 1.9 SDI, 2.0		<b>F8-8164</b>	

<b>F8-6281</b>	<b>F8-6396</b>	<b>F8-6460</b>	<b>F8-6461</b>	<b>F8-6462</b>	<b>F8-6532</b>	<b>F8-6533</b>
Ref.Nr.: 8Z0412331	Ref.Nr.: 03G105243	Ref.Nr.: 6Q0411314R	Ref.Nr.: 6Q0 411 314 M	Ref.Nr.: 6Q0411314L	Ref.Nr.: 6Q0 199 167 BC	Ref.Nr.: 6Q0 199 167 CA
<b>F8-6569</b>	<b>F8-6572</b>	<b>F8-6694</b>	<b>F8-6723</b>	<b>F8-6736</b>	<b>F8-6752</b>	<b>F8-7132</b>
Ref.Nr.: 6N0412249C	Ref.Nr.: 038105243L	Ref.Nr.: 6Q0411314F	Ref.Nr.: 6Q0512131B	Ref.Nr.: 1K0407183A	Ref.Nr.: 6Q0199167BN	Ref.Nr.: 6N0413175A
<b>F8-7675</b>	<b>F8-7676</b>	<b>F8-7830</b>	<b>F8-7873</b>	<b>F8-7914</b>	<b>F8-7928</b>	<b>F8-7949</b>
Ref.Nr.: 6Q0412301	Ref.Nr.: 6Q0412301A	Ref.Nr.: 6N0412303A	Ref.Nr.: 6Q0407182A	Ref.Nr.: 8Z0411314B	Ref.Nr.: 6Q0501541E	Ref.Nr.: 6Q0199851AK

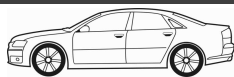
**Article Description****Article Nr.****Fitting Position**

<b>FABIA Saloon (6Y3)</b>				<b>10/1999 → 12/2007</b>	
Engine Mounting	1.9 TDI		<b>F8-8173</b>		
<b>FABIA</b>				<b>12/2006 → 12/2014</b>	
Alternator Freewheel Clutch	1.2 TDI, 1.4 TDI, 1.6 TDI, 1.9 TDI		<b>F5-1004</b>		
Alternator Freewheel Clutch	1.2 TSI, 1.4 TSI		<b>F5-1064</b>		
Alternator Freewheel Clutch	1.4 TDI		<b>F5-1085</b>		
Anti-Friction Bearing	1.2 12V, 1.2 TDI, 1.2 TSI, 1.4 TSI, 1.6 TDI	ch.5J-93120133, 5J-9A508237, 5J-9B505016, 5J-9K506834→; for OE: G02, G05; <b>ST</b>	<b>F8-3039</b>		H=14; d1=14; D=45
Anti-Friction Bearing	1.2 12V, 1.2 TDI, 1.2 TSI, 1.4 TSI, 1.6 TDI	ch.5J-93120133, 5J-9A508237, 5J-9B505016, 5J-9K506834→; for OE: G03; <b>Δ</b>	<b>F8-3039</b>		H=14; d1=14; D=45
Anti-Friction Bearing	1.2 12V, 1.2 TDI, 1.2 TSI, 1.4 TSI, 1.6 TDI	ch.5J-93120133, 5J-9A508237, 5J-9B505016, 5J-9K506834→; for OE: G04; <b>□</b>	<b>F8-3039</b>		H=14; d1=14; D=45
Anti-Friction Bearing	1.2, 1.4, 1.4 TDI, 1.6, 1.9 TDI	ch.5J-93120133, 5J-9A508237, 5J-9B505016, 5J-9K506834→; 01/2009 →; for OE: G02, G05; <b>ST</b>	<b>F8-3039</b>		H=14; d1=14; D=45
Anti-Friction Bearing	1.2, 1.4, 1.4 TDI, 1.6, 1.9 TDI	ch.5J-93120133, 5J-9A508237, 5J-9B505016, 5J-9K506834→; 01/2009 →; for OE: G03; <b>Δ</b>	<b>F8-3039</b>		H=14; d1=14; D=45
Anti-Friction Bearing	1.2, 1.4, 1.4 TDI, 1.6, 1.9 TDI	ch.5J-93120133, 5J-9A508237, 5J-9B505016, 5J-9K506834→; 01/2009 →; for OE: G04; <b>□</b>	<b>F8-3039</b>		H=14; d1=14; D=45
Top Strut Mounting	1.2 12V, 1.2 TDI, 1.2 TSI, 1.4 TSI, 1.6 TDI	for OE: G02, G03, G04, G07, G41; <b>Δ</b> , <b>SP</b> , <b>ST</b>	<b>F8-4067</b>		H=53; d=26; D=82
Top Strut Mounting	1.2, 1.4, 1.4 TDI, 1.6, 1.9 TDI	ch.5J-93120133, 5J-9A508237, 5J-9B505016, 5J-9K506834→; 01/2009 →; for OE: G02, G03, G04, G05; <b>Δ</b> , <b>SP</b> , <b>ST</b>	<b>F8-4067</b>		H=53; d=26; D=82
Top Strut Mounting	1.2, 1.4, 1.4 TDI, 1.6, 1.9 TDI		<b>F8-5380</b>		
Rubber Buffer, suspension	All Models		<b>F8-5381</b>		H=37; D=76
Engine Mounting	1.4, 1.6		<b>F8-5534</b>		
Top Strut Mounting	1.2, 1.4, 1.4 TDI, 1.6, 1.9 TDI	ch.→5J-93120132, 5J-9A508236, 5J-9B505015, 5J-9K506833; for OE: G02, G05; <b>Δ</b> ; <b>ST</b>	<b>F8-5537</b>		
Top Strut Mounting	1.2, 1.4, 1.4 TDI, 1.6, 1.9 TDI	ch.→5J-93120132, 5J-9A508236, 5J-9B505015, 5J-9K506833; for OE: G41; <b>Δ</b> ; <b>SP</b>	<b>F8-5537</b>		
Protective Cap/Bellow, shock absorber	1.2 12V, 1.2 TDI, 1.2 TSI, 1.4 TSI, 1.6 TDI	for OE: G02, G03, G04, G07, G41; <b>Δ</b> , <b>SP</b> , <b>ST</b>	<b>F8-5683</b>		H=210
Protective Cap/Bellow, shock absorber	1.2, 1.4, 1.4 TDI, 1.6, 1.9 TDI	ch.5J-93120133, 5J-9A508237, 5J-9B505016, 5J-9K506834→; 01/2009 →; for OE: G02, G03, G04, G05, G41; <b>Δ</b> , <b>SP</b> , <b>ST</b>	<b>F8-5683</b>		H=210

<b>F5-1004</b>	<b>F5-1064</b>	<b>F5-1085</b>	<b>F8-3039</b>	<b>F8-4067</b>	<b>F8-5380</b>	<b>F8-5381</b>
Ref.Nr.: 038903119T	Ref.Nr.: 03C903119D	Ref.Nr.: 045903119A	Ref.Nr.: 357412249A	Ref.Nr.: 1J0412331B	Ref.Nr.: 1J0513353G	Ref.Nr.: 1J0512149B
<b>F8-5534</b>	<b>F8-5537</b>	<b>F8-5683</b>	<b>F8-5993</b>	<b>F8-8173</b>		
Ref.Nr.: 6Q0199851AB	Ref.Nr.: 6N0412331E	Ref.Nr.: 357413175A	Ref.Nr.: 357412303F	Ref.Nr.: 6Q0199555AT		

Article Description

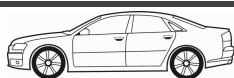

Article Nr.

Fitting Position



FABIA			12/2006 → 12/2014		
Rubber Buffer, suspension	1.2 12V, 1.2 TDI, 1.2 TSI, 1.4 TSI, 1.6 TDI	for OE: G03;	<b>F8-5993</b>		H=83
Rubber Buffer, suspension	1.2, 1.4, 1.4 TDI, 1.6, 1.9 TDI	ch.5J-93120133, 5J-9A508237, 5J-9B505016, 5J-9K506834→; 01/2009 →; for OE: G03;	<b>F8-5993</b>		H=83
Rubber Buffer, suspension	1.2 12V, 1.2 TDI, 1.2 TSI, 1.4 TSI, 1.6 TDI	for OE: G02;	<b>F8-5996</b>		H=63
Rubber Buffer, suspension	1.2 12V, 1.2 TDI, 1.2 TSI, 1.4 TSI, 1.6 TDI	for OE: G41; ,	<b>F8-5996</b>		H=63
Rubber Buffer, suspension	1.2, 1.4, 1.4 TDI, 1.6, 1.9 TDI	ch.5J-93120133, 5J-9A508237, 5J-9B505016, 5J-9K506834→; 01/2009 →; for OE: G02;	<b>F8-5996</b>		H=63
Rubber Buffer, suspension	1.2, 1.4, 1.4 TDI, 1.6, 1.9 TDI	ch.→6Y-1-160000, 6Y-1X012500	<b>F8-6002</b>		H=120
Rubber Buffer, suspension	All Models	for OE: G04, G07, G41; ,	<b>F8-6041</b>		H=53
Protective Cap/Bellow, shock absorber	All Models		<b>F8-6044</b>		H=160
Top Strut Mounting	1.2 12V, 1.2 TDI, 1.2 TSI, 1.4 TSI, 1.6 TDI	for OE: G02, G03, G04, G07, G41; , ,	<b>F8-6280</b>		H=53; d=26; D=82
Top Strut Mounting	1.2, 1.4, 1.4 TDI, 1.6, 1.9 TDI	ch.5J-93120133, 5J-9A508237, 5J-9B505016, 5J-9K506834→; 01/2009 →; for OE: G02, G03, G04, G05; , ,	<b>F8-6280</b>		H=53; d=26; D=82
Top Strut Mounting	1.2, 1.4, 1.4 TDI, 1.6, 1.9 TDI	ch.→5J-93120132, 5J-9A508236, 5J-9B505015, 5J-9K506833; for OE: G02, G05; ,	<b>F8-6281</b>		
Top Strut Mounting	1.2, 1.4, 1.4 TDI, 1.6, 1.9 TDI	ch.→5J-93120132, 5J-9A508236, 5J-9B505015, 5J-9K506833; for OE: G41; ,	<b>F8-6281</b>		
Belt Pulley, crankshaft	1.9 TDI	ch.5J-7-000001, 5J-8-000001→; Number of Ribs: 5; Parameter: 6PK	<b>F8-6396</b>		H=41.6; d=30; Mounting points diam.[mm]=7, 8.6; D=139.7
Stabiliser Mounting	1.2, 1.4, 1.4 TDI, 1.6, 1.9 TDI	ch.6Y-3-651671→	<b>F8-6460</b>		d=18
Stabiliser Mounting	1.2, 1.4, 1.4 TDI, 1.6, 1.9 TDI		<b>F8-6461</b>		d=17
Stabiliser Mounting	1.2, 1.4, 1.4 TDI, 1.6, 1.9 TDI	Stabi. Diam. [mm]= 18	<b>F8-6462</b>		d=16
Anti-Friction Bearing	1.2, 1.4, 1.4 TDI, 1.6, 1.9 TDI	ch.→5J-93120132, 5J-9A508236, 5J-9B505015, 5J-9K506833; for OE: G02, G05;	<b>F8-6569</b>		
Anti-Friction Bearing	1.2, 1.4, 1.4 TDI, 1.6, 1.9 TDI	ch.→5J-93120132, 5J-9A508236, 5J-9B505015, 5J-9K506833; for OE: G03;	<b>F8-6569</b>		
Anti-Friction Bearing	1.2, 1.4, 1.4 TDI, 1.6, 1.9 TDI	ch.→5J-93120132, 5J-9A508236, 5J-9B505015, 5J-9K506833; for OE: G04, G41;	<b>F8-6569</b>		
Belt Pulley, crankshaft	1.2 TDI, 1.6 TDI	Number of Ribs: 5; Parameter: 6PK	<b>F8-6572</b>		
Rubber Buffer, suspension	All Models		<b>F8-6723</b>		H=124
Protective Cap/Bellow, shock absorber	1.2, 1.4, 1.4 TDI, 1.6, 1.9 TDI	ch.→5J-93120132, 5J-9A508236, 5J-9B505015, 5J-9K506833; for OE: G02, G03, G04, G05, G41; , ,	<b>F8-7132</b>		H=190

<b>F8-5993</b>	<b>F8-5996</b>	<b>F8-6002</b>	<b>F8-6041</b>	<b>F8-6044</b>	<b>F8-6280</b>	<b>F8-6281</b>
Ref.Nr.: 357412303F	Ref.Nr.: 1H0412303B	Ref.Nr.: 6X0512131A	Ref.Nr.: 1J0412303	Ref.Nr.: 3C0513425	Ref.Nr.: 6R0412249	Ref.Nr.: 8Z0412331
<b>F8-6396</b>	<b>F8-6460</b>	<b>F8-6461</b>	<b>F8-6462</b>	<b>F8-6569</b>	<b>F8-6572</b>	<b>F8-6723</b>
Ref.Nr.: 03G105243	Ref.Nr.: 6Q0411314R	Ref.Nr.: 6Q0 411 314 M	Ref.Nr.: 6Q0411314L	Ref.Nr.: 6N0412249C	Ref.Nr.: 038105243L	Ref.Nr.: 6Q0512131B
<b>F8-7132</b>	<b>F8-7133</b>					
Ref.Nr.: 6N0413175A	Ref.Nr.: 1J0412319C					



**Article Description**

**Article Nr.**
**Fitting Position**

<b>FABIA</b>			<b>12/2006 → 12/2014</b>		
Top Strut Mounting	1.2 12V, 1.2 TDI, 1.2 TSI, 1.4 TSI, 1.6 TDI	for OE: 1J0412319C	<b>F8-7133</b>		
Top Strut Mounting	1.2, 1.4, 1.4 TDI, 1.6, 1.9 TDI	ch.5J-93120133, 5J-9A508237, 5J-9B505016, 5J-9K506834→; 01/2009 →; for OE: 1J0412319C	<b>F8-7133</b>		
Rubber Buffer, suspension	1.2, 1.2 TDI, 1.2 TSI, 1.4, 1.4 TDI, 1.4 TSI, 1.6, 1.6 TDI, 1.9 TDI	for OE: 1JD;	<b>F8-7658</b>		H=114
Rubber Buffer, suspension	1.2, 1.4, 1.4 TDI, 1.6, 1.9 TDI	ch.→5J-93120132, 5J-9A508236, 5J-9B505015, 5J-9K506833; for OE: G03;	<b>F8-7675</b>		H=84
Rubber Buffer, suspension	1.2, 1.4, 1.4 TDI, 1.6, 1.9 TDI	ch.→5J-93120132, 5J-9A508236, 5J-9B505015, 5J-9K506833; for OE: G02, G05;	<b>F8-7830</b>		
Control Arm-/Trailing Arm Bush	1.2, 1.4, 1.4 TDI, 1.6, 1.9 TDI	ch.→5J-83172973, 5J-8A502656, 5J-8B503031, 5J-8K450960	<b>F8-7873</b>		
Engine Mounting	1.4, 1.6		<b>F8-7949</b>		
Engine Mounting	1.4 TDI		<b>F8-7950</b>		
Engine Mounting	1.2		<b>F8-7955</b>		
Engine Mounting	1.2	BBM;  5-speed	<b>F8-7955</b>		
Engine Mounting	1.2	CHFA	<b>F8-7955</b>		
Engine Mounting	1.9 TDI		<b>F8-7956</b>		
Control Arm-/Trailing Arm Bush	All Models		<b>F8-7978</b>		
Belt Pulley, crankshaft	1.4 TDI	Number of Ribs: 5; Parameter: 6PK	<b>F8-8038</b>		
Engine Mounting	1.4 TDI, 1.6		<b>F8-8164</b>		
Engine Mounting	1.2	CGPA;  7-speed	<b>F8-8173</b>		
Engine Mounting	1.2	CHFA;  7-speed	<b>F8-8173</b>		
Engine Mounting	1.2 TSI, 1.6	7-speed	<b>F8-8173</b>		
Engine Mounting	1.4	CGGB;  7-speed	<b>F8-8173</b>		
Engine Mounting	1.4 TSI	CAVE;  7-speed	<b>F8-8173</b>		
Engine Mounting	1.6	ch.5J-83-172947, 5J-8A-502657, 5J-8B-503032, 5J-8K-450961→;	<b>F8-8173</b>		
Engine Mounting	1.9 TDI	5-speed	<b>F8-8173</b>		
<b>FABIA Combi</b>			<b>10/2007 → 12/2014</b>		
Alternator Freewheel Clutch	1.2 TDI, 1.4 TDI, 1.6 TDI, 1.9 TDI		<b>F5-1004</b>		
Alternator Freewheel Clutch	1.2 TSI, 1.4 TSI		<b>F5-1064</b>		
Alternator Freewheel Clutch	1.4 TDI		<b>F5-1085</b>		
Anti-Friction Bearing	1.2 12V, 1.2 TDI, 1.2 TSI, 1.4 TSI, 1.6 TDI	ch.5J-93120133, 5J-9A508237, 5J-9B505016, 5J-9K506834→; for OE: G02, G05;	<b>F8-3039</b>		H=14; d1=14; D=45

<b>F5-1004</b>	<b>F5-1064</b>	<b>F5-1085</b>	<b>F8-3039</b>	<b>F8-7133</b>	<b>F8-7658</b>	<b>F8-7675</b>
Ref.Nr.: 038903119T	Ref.Nr.: 03C903119D	Ref.Nr.: 045903119A	Ref.Nr.: 357412249A	Ref.Nr.: 1J0412319C	Ref.Nr.: 6Q0512131C	Ref.Nr.: 6Q0412301
<b>F8-7830</b>	<b>F8-7873</b>	<b>F8-7949</b>	<b>F8-7950</b>	<b>F8-7955</b>	<b>F8-7956</b>	<b>F8-7978</b>
Ref.Nr.: 6N0412303A	Ref.Nr.: 6Q0407182A	Ref.Nr.: 6Q0199851AK	Ref.Nr.: 6Q0199851AQ	Ref.Nr.: 6Q0199851AJ	Ref.Nr.: 6Q0199851AP	Ref.Nr.: 357407182F
<b>F8-8038</b>	<b>F8-8164</b>	<b>F8-8173</b>				
Ref.Nr.: 045105243C	Ref.Nr.: 6Q0199555AS	Ref.Nr.: 6Q0199555AT				

Article Description



Article Nr.

Fitting Position



FABIA Combi			10/2007 → 12/2014		
Anti-Friction Bearing	1.2 12V, 1.2 TDI, 1.2 TSI, 1.4 TSI, 1.6 TDI	ch.5J-93120133, 5J-9A508237, 5J-9B505016, 5J-9K506834→; for OE: G03;	<b>F8-3039</b>		H=14; d1=14; D=45
Anti-Friction Bearing	1.2 12V, 1.2 TDI, 1.2 TSI, 1.4, 1.4 TSI, 1.6 TDI	ch.5J-93120133, 5J-9A508237, 5J-9B505016, 5J-9K506834→; for OE: G04;	<b>F8-3039</b>		H=14; d1=14; D=45
Anti-Friction Bearing	1.2, 1.4 TDI, 1.6, 1.9 TDI	ch.5J-93120133, 5J-9A508237, 5J-9B505016, 5J-9K506834→; 01/2009 →; for OE: G04;	<b>F8-3039</b>		H=14; d1=14; D=45
Anti-Friction Bearing	1.2, 1.4, 1.4 TDI, 1.6, 1.9 TDI	ch.5J-93120133, 5J-9A508237, 5J-9B505016, 5J-9K506834→; 01/2009 →; for OE: G02, G05;	<b>F8-3039</b>		H=14; d1=14; D=45
Anti-Friction Bearing	1.2, 1.4, 1.4 TDI, 1.6, 1.9 TDI	ch.5J-93120133, 5J-9A508237, 5J-9B505016, 5J-9K506834→; 01/2009 →; for OE: G03;	<b>F8-3039</b>		H=14; d1=14; D=45
Top Strut Mounting	1.2 12V, 1.2 TDI, 1.2 TSI, 1.4 TSI, 1.6 TDI	for OE: G02, G03, G04, G07, G41; ; ; ;	<b>F8-4067</b>		H=53; d=26; D=82
Top Strut Mounting	1.2, 1.4, 1.4 TDI, 1.6, 1.9 TDI	ch.5J-93120133, 5J-9A508237, 5J-9B505016, 5J-9K506834→; 01/2009 →; for OE: G02, G03, G04, G05; ; ;	<b>F8-4067</b>		H=53; d=26; D=82
Top Strut Mounting	1.2, 1.4, 1.4 TDI, 1.6, 1.9 TDI		<b>F8-5380</b>		
Rubber Buffer, suspension	All Models		<b>F8-5381</b>		H=37; D=76
Engine Mounting	1.4, 1.6	5-speed	<b>F8-5534</b>		
Top Strut Mounting	1.2, 1.4, 1.4 TDI, 1.6, 1.9 TDI	ch.→5J-93120132, 5J-9A508236, 5J-9B505015, 5J-9K506833; for OE: G02, G05; ;	<b>F8-5537</b>		
Top Strut Mounting	1.2, 1.4, 1.4 TDI, 1.6, 1.9 TDI	ch.→5J-93120132, 5J-9A508236, 5J-9B505015, 5J-9K506833; for OE: G41; ;	<b>F8-5537</b>		
Protective Cap/Bellow, shock absorber	1.2 12V, 1.2 TDI, 1.2 TSI, 1.4 TSI, 1.6 TDI	for OE: G02, G03, G04, G07, G41; ; ;	<b>F8-5683</b>		H=210
Protective Cap/Bellow, shock absorber	1.2, 1.4, 1.4 TDI, 1.6, 1.9 TDI	ch.5J-93120133, 5J-9A508237, 5J-9B505016, 5J-9K506834→; 01/2009 →; for OE: G02, G03, G04, G05, G41; ; ;	<b>F8-5683</b>		H=210
Rubber Buffer, suspension	1.2 12V, 1.2 TDI, 1.2 TSI, 1.4 TSI, 1.6 TDI	for OE: G03;	<b>F8-5993</b>		H=83
Rubber Buffer, suspension	1.2, 1.4, 1.4 TDI, 1.6, 1.9 TDI	ch.5J-93120133, 5J-9A508237, 5J-9B505016, 5J-9K506834→; 01/2009 →; for OE: G03;	<b>F8-5993</b>		H=83
Rubber Buffer, suspension	1.2 12V, 1.2 TDI, 1.2 TSI, 1.4 TSI, 1.6 TDI	for OE: G02;	<b>F8-5996</b>		H=63
Rubber Buffer, suspension	1.2 12V, 1.2 TDI, 1.2 TSI, 1.4 TSI, 1.6 TDI	for OE: G41; ;	<b>F8-5996</b>		H=63
Rubber Buffer, suspension	1.2, 1.4, 1.4 TDI, 1.6, 1.9 TDI	ch.5J-93120133, 5J-9A508237, 5J-9B505016, 5J-9K506834→; 01/2009 →; for OE: G02;	<b>F8-5996</b>		H=63

<b>F8-3039</b>	<b>F8-4067</b>	<b>F8-5380</b>	<b>F8-5381</b>	<b>F8-5534</b>	<b>F8-5537</b>	<b>F8-5683</b>
Ref.Nr.: 357412249A	Ref.Nr.: 1J0412331B	Ref.Nr.: 1J0513353G	Ref.Nr.: 1J0512149B	Ref.Nr.: 6Q0199851AB	Ref.Nr.: 6N0412331E	Ref.Nr.: 357413175A
<b>F8-5993</b>	<b>F8-5996</b>	<b>F8-6041</b>				
Ref.Nr.: 357412303F	Ref.Nr.: 1H0412303B	Ref.Nr.: 1J0412303				

**Article Description****Article Nr.****Fitting Position**

<b>FABIA Combi</b>			<b>10/2007 → 12/2014</b>		
Rubber Buffer, suspension	All Models	for OE: G04, G07, G41;	<b>F8-6041</b>		H=53
Protective Cap/Bellow, shock absorber	All Models		<b>F8-6044</b>		H=160
Top Strut Mounting	1.2 12V, 1.2 TDI, 1.2 TSI, 1.4 TSI, 1.6 TDI	for OE: G02, G03, G04, G07, G41;	<b>F8-6280</b>		H=53; d=26; D=82
Top Strut Mounting	1.2, 1.4, 1.4 TDI, 1.6, 1.9 TDI	ch.5J-93120133, 5J-9A508237, 5J-9B505016, 5J-9K506834 →; 01/2009 →; for OE: G02, G03, G04, G05;	<b>F8-6280</b>		H=53; d=26; D=82
Top Strut Mounting	1.2, 1.4, 1.4 TDI, 1.6, 1.9 TDI	ch.→5J-93120132, 5J-9A508236, 5J-9B505015, 5J-9K506833; for OE: G02, G05;	<b>F8-6281</b>		
Top Strut Mounting	1.2, 1.4, 1.4 TDI, 1.6, 1.9 TDI	ch.→5J-93120132, 5J-9A508236, 5J-9B505015, 5J-9K506833; for OE: G41;	<b>F8-6281</b>		
Belt Pulley, crankshaft	1.9 TDI	ch.5J-7-000001, 5J-8-000001 →; Number of Ribs: 5; Parameter: 6PK	<b>F8-6396</b>		H=41.6; d=30; Mounting points diam.[mm]=7, 8.6; D=139.7
Stabiliser Mounting	1.2, 1.4, 1.4 TDI, 1.6, 1.9 TDI	ch.6Y-3-651671 →	<b>F8-6460</b>		d=18
Stabiliser Mounting	1.2, 1.4, 1.4 TDI, 1.6, 1.9 TDI		<b>F8-6461</b>		d=17
Stabiliser Mounting	1.2, 1.4, 1.4 TDI, 1.6, 1.9 TDI	Stabi. Diam. [mm]= 18	<b>F8-6462</b>		d=16
Anti-Friction Bearing	1.2, 1.4, 1.4 TDI, 1.6, 1.9 TDI	ch.→5J-93120132, 5J-9A508236, 5J-9B505015, 5J-9K506833; for OE: G02, G05;	<b>F8-6569</b>		
Anti-Friction Bearing	1.2, 1.4, 1.4 TDI, 1.6, 1.9 TDI	ch.→5J-93120132, 5J-9A508236, 5J-9B505015, 5J-9K506833; for OE: G03;	<b>F8-6569</b>		
Anti-Friction Bearing	1.2, 1.4, 1.4 TDI, 1.6, 1.9 TDI	ch.→5J-93120132, 5J-9A508236, 5J-9B505015, 5J-9K506833; for OE: G04, G41;	<b>F8-6569</b>		
Belt Pulley, crankshaft	1.2 TDI, 1.6 TDI	Number of Ribs: 5; Parameter: 6PK	<b>F8-6572</b>		
Rubber Buffer, suspension	1.2, 1.4, 1.4 TDI, 1.6, 1.9 TDI		<b>F8-6723</b>		H=124
Protective Cap/Bellow, shock absorber	1.2, 1.4, 1.4 TDI, 1.6, 1.9 TDI	ch.→5J-93120132, 5J-9A508236, 5J-9B505015, 5J-9K506833; for OE: G02, G03, G04, G05, G41;	<b>F8-7132</b>		H=190
Top Strut Mounting	1.2 12V, 1.2 TDI, 1.2 TSI, 1.4 TSI, 1.6 TDI	for OE: 1J0412319C	<b>F8-7133</b>		
Top Strut Mounting	1.2, 1.4, 1.4 TDI, 1.6, 1.9 TDI	ch.5J-93120133, 5J-9A508237, 5J-9B505016, 5J-9K506834 →; 01/2009 →; for OE: 1J0412319C	<b>F8-7133</b>		
Rubber Buffer, suspension	1.2, 1.2 TDI, 1.2 TSI, 1.4, 1.4 TDI, 1.4 TSI, 1.6, 1.6 TDI, 1.9 TDI	for OE: 1JD;	<b>F8-7658</b>		H=114
Rubber Buffer, suspension	1.2, 1.4, 1.4 TDI, 1.6, 1.9 TDI	ch.→5J-93120132, 5J-9A508236, 5J-9B505015, 5J-9K506833; for OE: G03;	<b>F8-7675</b>		H=84

<b>F8-6041</b>	<b>F8-6044</b>	<b>F8-6280</b>	<b>F8-6281</b>	<b>F8-6396</b>	<b>F8-6460</b>	<b>F8-6461</b>
Ref.Nr.: 1J0412303	Ref.Nr.: 3C0513425	Ref.Nr.: 6R0412249	Ref.Nr.: 8Z0412331	Ref.Nr.: 03G105243	Ref.Nr.: 6Q0411314R	Ref.Nr.: 6Q0 411 314 M
<b>F8-6462</b>	<b>F8-6569</b>	<b>F8-6572</b>	<b>F8-6723</b>	<b>F8-7132</b>	<b>F8-7133</b>	<b>F8-7658</b>
Ref.Nr.: 6Q0411314L	Ref.Nr.: 6N0412249C	Ref.Nr.: 038105243L	Ref.Nr.: 6Q0512131B	Ref.Nr.: 6N0413175A	Ref.Nr.: 1J0412319C	Ref.Nr.: 6Q0512131C
<b>F8-7675</b>	<b>F8-7830</b>					
Ref.Nr.: 6Q0412301	Ref.Nr.: 6N0412303A					

Article Description



Article Nr.

Fitting Position



<b>FABIA Combi</b>			<b>10/2007 → 12/2014</b>	
Rubber Buffer, suspension	1.2, 1.4, 1.4 TDI, 1.6, 1.9 TDI	ch.→5J-93120132, 5J-9A508236, 5J-9B505015, 5J-9K506833; for OE: G02, G05; <b>ST</b>	<b>F8-7830</b>	
Engine Mounting	1.4, 1.6		<b>F8-7949</b>	
Engine Mounting	1.2		<b>F8-7955</b>	
Engine Mounting	1.2	BBM;  5-speed	<b>F8-7955</b>	
Engine Mounting	1.2	CHFA	<b>F8-7955</b>	
Engine Mounting	1.9 TDI		<b>F8-7956</b>	
Control Arm-/Trailing Arm Bush	All Models		<b>F8-7978</b>	
Belt Pulley, crankshaft	1.4 TDI	Number of Ribs: 5; Parameter: 6PK	<b>F8-8038</b>	
Engine Mounting	1.4 TDI, 1.6		<b>F8-8164</b>	
Engine Mounting	1.2	CGPA;  7-speed	<b>F8-8173</b>	
Engine Mounting	1.2	CHFA;  7-speed	<b>F8-8173</b>	
Engine Mounting	1.2 TSI, 1.6	7-speed	<b>F8-8173</b>	
Engine Mounting	1.4	CGGB;  7-speed	<b>F8-8173</b>	
Engine Mounting	1.4 TSI	CAVE;  7-speed	<b>F8-8173</b>	
Engine Mounting	1.6	ch.5J-83-172947, 5J-8A-502657, 5J-8B-503032, 5J-8K-450961→;	<b>F8-8173</b>	
Engine Mounting	1.9 TDI	5-speed	<b>F8-8173</b>	
<b>FAVORIT (781)</b>			<b>05/1989 → 09/1994</b>	
Dust Cover Kit, shock absorber	1.3, 1.3 135, 1.3 135 X,LX,GLX, 1.3 135L, 1.3 136		<b>AK-732516</b>	
Dust Cover Kit, shock absorber	1.3, 1.3 135, 1.3 135 X,LX,GLX, 1.3 135L, 1.3 136		<b>AK-735116</b>	
Top Strut Mounting	1.3, 1.3 135, 1.3 135 X,LX,GLX, 1.3 135L, 1.3 136		<b>F8-5550</b>	
Rubber Buffer, suspension	1.3 135, 1.3 135 X,LX,GLX, 1.3 136		<b>F8-5993</b>	H=83
Repair Kit, suspension strut	1.3, 1.3 135, 1.3 135 X,LX,GLX, 1.3 135L, 1.3 136		<b>F8-6345</b>	
Top Strut Mounting	1.3, 1.3 135, 1.3 135 X,LX,GLX, 1.3 135L, 1.3 136	for OE: 6U0512333	<b>F8-7098</b>	
Top Strut Mounting	1.3, 1.3 135, 1.3 135 X,LX,GLX, 1.3 135L, 1.3 136	for OE: 6U0512335	<b>F8-7099</b>	
Rubber Buffer, suspension	1.3, 1.3 135, 1.3 135 X,LX,GLX, 1.3 135L, 1.3 136		<b>F8-7674</b>	H=155
Control Arm-/Trailing Arm Bush	1.3, 1.3 135, 1.3 135 X,LX,GLX, 1.3 135L, 1.3 136		<b>G9-678</b>	
Control Arm-/Trailing Arm Bush	1.3, 1.3 135, 1.3 135 X,LX,GLX, 1.3 135L, 1.3 136		<b>G9-679</b>	
Control Arm-/Trailing Arm Bush	1.3, 1.3 135, 1.3 135 X,LX,GLX, 1.3 135L, 1.3 136		<b>G9-680</b>	H=51; d=17; W=47
<b>FAVORIT Forman (785)</b>			<b>08/1991 → 06/1995</b>	
Dust Cover Kit, shock absorber	1.3		<b>AK-732516</b>	
Dust Cover Kit, shock absorber	1.3		<b>AK-735116</b>	

<b>AK-732516</b>	<b>AK-735116</b>	<b>F8-5550</b>	<b>F8-5993</b>	<b>F8-6345</b>	<b>F8-7098</b>	<b>F8-7099</b>
Ref.Nr.:	Ref.Nr.:	Ref.Nr.: 6U0412355	Ref.Nr.: 357412303F	Ref.Nr.: 6U0512335S	Ref.Nr.: 6U0512333	Ref.Nr.: 115395801
<b>F8-7674</b>	<b>F8-7830</b>	<b>F8-7949</b>	<b>F8-7955</b>	<b>F8-7956</b>	<b>F8-7978</b>	<b>F8-8038</b>
Ref.Nr.: 6U0512131C	Ref.Nr.: 6N0412303A	Ref.Nr.: 6Q0199851AK	Ref.Nr.: 6Q0199851AJ	Ref.Nr.: 6Q0199851AP	Ref.Nr.: 357407182F	Ref.Nr.: 045105243C
<b>F8-8164</b>	<b>F8-8173</b>	<b>G9-678</b>	<b>G9-679</b>	<b>G9-680</b>		
Ref.Nr.: 6Q0199555AS	Ref.Nr.: 6Q0199555AT	Ref.Nr.: 115422290	Ref.Nr.: 115422291	Ref.Nr.: 115422292		

**Article Description****Article Nr.****Fitting Position**

<b>FAVORIT Forman (785)</b>				<b>08/1991 → 06/1995</b>	
Top Strut Mounting	1.3		<b>F8-5550</b>		
Rubber Buffer, suspension	1.3		<b>F8-5993</b>		H=83
Repair Kit, suspension strut	1.3		<b>F8-6345</b>		
Top Strut Mounting	1.3	for OE: 6U0512333	<b>F8-7098</b>		
Top Strut Mounting	1.3	for OE: 6U0512335	<b>F8-7099</b>		
Rubber Buffer, suspension	1.3		<b>F8-7674</b>		H=155
Control Arm-/Trailing Arm Bush	1.3		<b>G9-678</b>		
Control Arm-/Trailing Arm Bush	1.3		<b>G9-679</b>		
Control Arm-/Trailing Arm Bush	1.3		<b>G9-680</b>		H=51; d=17; W=47
<b>FAVORIT Pickup (787)</b>				<b>12/1992 → 06/1997</b>	
Dust Cover Kit, shock absorber	All Models		<b>AK-732516</b>		
Dust Cover Kit, shock absorber	All Models		<b>AK-735116</b>		
Top Strut Mounting	All Models		<b>F8-5550</b>		
Repair Kit, suspension strut	All Models		<b>F8-6345</b>		
Top Strut Mounting	All Models	for OE: 6U0512333	<b>F8-7098</b>		
Top Strut Mounting	All Models	for OE: 6U0512335	<b>F8-7099</b>		
Rubber Buffer, suspension	All Models		<b>F8-7674</b>		H=155
Control Arm-/Trailing Arm Bush	All Models		<b>G9-678</b>		
Control Arm-/Trailing Arm Bush	All Models		<b>G9-680</b>		H=51; d=17; W=47
<b>FELICIA (6U1)</b>				<b>10/1994 → 03/1998</b>	
Dust Cover Kit, shock absorber	All Models		<b>AK-732516</b>		
Dust Cover Kit, shock absorber	All Models		<b>AK-735065</b>		
Alternator Freewheel Clutch	1.6 LX		<b>F5-1007</b>		
Alternator Freewheel Clutch	1.9 D		<b>F5-1010</b>		
Control Arm-/Trailing Arm Bush	All Models		<b>F8-5290</b>		
Control Arm-/Trailing Arm Bush	All Models		<b>F8-5291</b>		
Top Strut Mounting	All Models		<b>F8-5550</b>		
Rubber Buffer, suspension	1.3, 1.6 LX, 1.9 D		<b>F8-5993</b>		H=83
Repair Kit, suspension strut	All Models		<b>F8-6345</b>		
Belt Pulley, crankshaft	1.9 D	Number of Ribs: 5	<b>F8-6398</b>		
Rod/Strut, stabiliser	All Models	Coupling Rod	<b>F8-6695</b>		

<b>AK-732516</b>	<b>AK-735065</b>	<b>AK-735116</b>	<b>F5-1007</b>	<b>F5-1010</b>	<b>F8-5290</b>	<b>F8-5291</b>
Ref.Nr.:	Ref.Nr.: 6U0413175	Ref.Nr.:	Ref.Nr.: 028903119AQ	Ref.Nr.: 028903119S	Ref.Nr.: 007296379	Ref.Nr.: 007296377
<b>F8-5550</b>	<b>F8-5993</b>	<b>F8-6345</b>	<b>F8-6398</b>	<b>F8-6695</b>	<b>F8-6808</b>	<b>F8-7098</b>
Ref.Nr.: 6U0412355	Ref.Nr.: 357412303F	Ref.Nr.: 6U0512335S	Ref.Nr.: 028 105 243AC	Ref.Nr.: 6U0411315	Ref.Nr.: 6U0407182C	Ref.Nr.: 6U0512333
<b>F8-7099</b>	<b>F8-7674</b>	<b>G9-678</b>	<b>G9-679</b>	<b>G9-680</b>		
Ref.Nr.: 115395801	Ref.Nr.: 6U0512131C	Ref.Nr.: 115422290	Ref.Nr.: 115422291	Ref.Nr.: 115422292		

Article Description



Article Nr.

Fitting Position



<b>FELICIA (6U1)</b>				<b>10/1994 → 03/1998</b>	
Control Arm-/Trailing Arm Bush	All Models		<b>F8-6808</b>		
Top Strut Mounting	All Models	for OE: 6U0512333	<b>F8-7098</b>		
Top Strut Mounting	All Models	for OE: 6U0512335	<b>F8-7099</b>		
Rubber Buffer, suspension	All Models		<b>F8-7674</b>		
Control Arm-/Trailing Arm Bush	All Models		<b>G9-678</b>		
Bellow, steering	1.3, 1.6 LX, 1.9 D	with clamps;	<b>LM-10063S</b>		d1=11; d2=42; L [mm]=208
<b>FELICIA Pickup (797)</b>				<b>06/1997 → 04/2002</b>	
Dust Cover Kit, shock absorber	1.3, 1.6, 1.9 D		<b>AK-732516</b>		
Dust Cover Kit, shock absorber	1.3, 1.6, 1.9 D		<b>AK-735065</b>		
Alternator Freewheel Clutch	1.6		<b>F5-1007</b>		
Alternator Freewheel Clutch	1.9 D		<b>F5-1010</b>		
Control Arm-/Trailing Arm Bush	1.3, 1.6, 1.9 D		<b>F8-5290</b>		
Control Arm-/Trailing Arm Bush	1.3, 1.6, 1.9 D		<b>F8-5291</b>		
Top Strut Mounting	1.3, 1.6, 1.9 D		<b>F8-5550</b>		
Rubber Buffer, suspension	1.6, 1.9 D		<b>F8-5993</b>		
Repair Kit, suspension strut	1.3, 1.6, 1.9 D		<b>F8-6345</b>		
Rod/Strut, stabiliser	1.3, 1.6, 1.9 D	Coupling Rod	<b>F8-6695</b>		
Control Arm-/Trailing Arm Bush	1.3, 1.6, 1.9 D		<b>F8-6808</b>		
Top Strut Mounting	1.3, 1.6, 1.9 D	for OE: 6U0512333	<b>F8-7098</b>		
Top Strut Mounting	1.3, 1.6, 1.9 D	for OE: 6U0512335	<b>F8-7099</b>		
Rubber Buffer, suspension	1.3, 1.6, 1.9 D		<b>F8-7674</b>		
Control Arm-/Trailing Arm Bush	1.3, 1.6, 1.9 D		<b>G9-678</b>		
Bellow, steering	1.9 D	with clamps;	<b>LM-10063S</b>		d1=11; d2=42; L [mm]=208
<b>FELICIA Estate (6U5)</b>				<b>08/1995 → 03/1998</b>	
Dust Cover Kit, shock absorber	All Models		<b>AK-732516</b>		
Dust Cover Kit, shock absorber	All Models		<b>AK-735065</b>		
Alternator Freewheel Clutch	1.6 GLX		<b>F5-1007</b>		
Alternator Freewheel Clutch	1.9 D		<b>F5-1010</b>		
Control Arm-/Trailing Arm Bush	All Models		<b>F8-5290</b>		
Control Arm-/Trailing Arm Bush	All Models		<b>F8-5291</b>		

<b>AK-732516</b>	<b>AK-735065</b>	<b>F5-1007</b>	<b>F5-1010</b>	<b>F8-5290</b>	<b>F8-5291</b>	<b>F8-5550</b>
Ref.Nr.:	Ref.Nr.: 6U0413175	Ref.Nr.: 028903119AQ	Ref.Nr.: 028903119S	Ref.Nr.: 007296379	Ref.Nr.: 007296377	Ref.Nr.: 6U0412355
<b>F8-5993</b>	<b>F8-6345</b>	<b>F8-6695</b>	<b>F8-6808</b>	<b>F8-7098</b>	<b>F8-7099</b>	<b>F8-7674</b>
Ref.Nr.: 357412303F	Ref.Nr.: 6U0512335S	Ref.Nr.: 6U0411315	Ref.Nr.: 6U0407182C	Ref.Nr.: 6U0512333	Ref.Nr.: 115395801	Ref.Nr.: 6U051231C
<b>G9-678</b>	<b>LM-10063S</b>					
Ref.Nr.: 115422290	Ref.Nr.: 6N0422831					

**Article Description****Article Nr.****Fitting Position**

<b>FELICIA Estate (6U5)</b>			<b>08/1995 → 03/1998</b>		
Top Strut Mounting	All Models		<b>F8-5550</b>		
Rubber Buffer, suspension	All Models		<b>F8-5993</b>		H=83
Repair Kit, suspension strut	All Models		<b>F8-6345</b>		
Belt Pulley, crankshaft	1.9 D	Number of Ribs: 5	<b>F8-6398</b>		
Rod/Strut, stabiliser	All Models	Coupling Rod	<b>F8-6695</b>		
Control Arm-/Trailing Arm Bush	All Models		<b>F8-6808</b>		
Top Strut Mounting	All Models	for OE: 6U0512333	<b>F8-7098</b>		
Top Strut Mounting	All Models	for OE: 6U0512335	<b>F8-7099</b>		
Rubber Buffer, suspension	All Models		<b>F8-7674</b>		H=155
Control Arm-/Trailing Arm Bush	All Models		<b>G9-678</b>		
Bellow, steering	1.3, 1.3 LX, 1.3 LXI	with clamps;	<b>LM-10063S</b>		d1=11; d2=42; L [mm]=208
Bellow, steering	1.6 GLX, 1.9 D	with clamps	<b>LM-10063S</b>		d1=11; d2=42; L [mm]=208
<b>FELICIA Mk II (6U1)</b>			<b>01/1998 → 06/2001</b>		
Dust Cover Kit, shock absorber	All Models		<b>AK-732516</b>		
Dust Cover Kit, shock absorber	All Models		<b>AK-735065</b>		
Alternator Freewheel Clutch	1.6		<b>F5-1007</b>		
Alternator Freewheel Clutch	1.9 D		<b>F5-1010</b>		
Control Arm-/Trailing Arm Bush	All Models		<b>F8-5290</b>		
Control Arm-/Trailing Arm Bush	All Models		<b>F8-5291</b>		
Top Strut Mounting	All Models		<b>F8-5550</b>		
Rubber Buffer, suspension	All Models		<b>F8-5993</b>		H=83
Repair Kit, suspension strut	All Models		<b>F8-6345</b>		
Belt Pulley, crankshaft	1.9 D	Number of Ribs: 5	<b>F8-6398</b>		
Rod/Strut, stabiliser	All Models	Coupling Rod	<b>F8-6695</b>		
Control Arm-/Trailing Arm Bush	All Models		<b>F8-6808</b>		
Top Strut Mounting	All Models	for OE: 6U0512333	<b>F8-7098</b>		
Top Strut Mounting	All Models	for OE: 6U0512335	<b>F8-7099</b>		
Rubber Buffer, suspension	All Models		<b>F8-7674</b>		H=155
Control Arm-/Trailing Arm Bush	All Models		<b>G9-678</b>		
Bellow, steering	1.3, 1.6, 1.9 D	with clamps;	<b>LM-10063S</b>		d1=11; d2=42; L [mm]=208

<b>AK-732516</b>	<b>AK-735065</b>	<b>F5-1007</b>	<b>F5-1010</b>	<b>F8-5290</b>	<b>F8-5291</b>	<b>F8-5550</b>
Ref.Nr.:	Ref.Nr.: 6U0413175	Ref.Nr.: 028903119AQ	Ref.Nr.: 028903119S	Ref.Nr.: 007296379	Ref.Nr.: 007296377	Ref.Nr.: 6U0412355
<b>F8-5993</b>	<b>F8-6345</b>	<b>F8-6398</b>	<b>F8-6695</b>	<b>F8-6808</b>	<b>F8-7098</b>	<b>F8-7099</b>
Ref.Nr.: 357412303F	Ref.Nr.: 6U0512335S	Ref.Nr.: 028 105 243AC	Ref.Nr.: 6U0411315	Ref.Nr.: 6U0407182C	Ref.Nr.: 6U0512333	Ref.Nr.: 115395801
<b>F8-7674</b>	<b>G9-678</b>	<b>LM-10063S</b>				
Ref.Nr.: 6U0512131C	Ref.Nr.: 115422290	Ref.Nr.: 6N0422831				

Article Description



Article Nr.

Fitting Position



<b>FELICIA Mk II Estate (6U5)</b>			<b>01/1998 → 06/2001</b>	
Dust Cover Kit, shock absorber	All Models		<b>AK-732516</b>	
Dust Cover Kit, shock absorber	All Models		<b>AK-735065</b>	
Alternator Freewheel Clutch	1.6		<b>F5-1007</b>	
Alternator Freewheel Clutch	1.9 D		<b>F5-1010</b>	
Control Arm-/Trailing Arm Bush	All Models		<b>F8-5290</b>	
Control Arm-/Trailing Arm Bush	All Models		<b>F8-5291</b>	
Top Strut Mounting	All Models		<b>F8-5550</b>	
Rubber Buffer, suspension	All Models		<b>F8-5993</b>	H=83
Repair Kit, suspension strut	All Models		<b>F8-6345</b>	
Belt Pulley, crankshaft	1.9 D	Number of Ribs: 5	<b>F8-6398</b>	
Rod/Strut, stabiliser	All Models	Coupling Rod	<b>F8-6695</b>	
Control Arm-/Trailing Arm Bush	All Models		<b>F8-6808</b>	
Top Strut Mounting	All Models	for OE: 6U0512333	<b>F8-7098</b>	
Top Strut Mounting	All Models	for OE: 6U0512335	<b>F8-7099</b>	
Rubber Buffer, suspension	All Models		<b>F8-7674</b>	H=155
Control Arm-/Trailing Arm Bush	All Models		<b>G9-678</b>	
Bellow, steering	1.3	with clamps;	<b>LM-10063S</b>	d1=11; d2=42; L [mm]=208
Bellow, steering	1.6, 1.9 D	with clamps	<b>LM-10063S</b>	d1=11; d2=42; L [mm]=208
<b>OCTAVIA (1U2)</b>			<b>09/1996 → 12/2010</b>	
Dust Cover Kit, shock absorber	All Models		<b>AK-735039</b>	
Dust Cover Kit, shock absorber	All Models		<b>AK-735095</b>	
Dust Cover Kit, shock absorber	All Models	<b>ST</b>	<b>AK-735410</b>	H=210
Alternator Freewheel Clutch	1.6, 1.8 T, 1.8 T 4x4, 1.9 SDI, 1.9 TDI, 2.0, RS 1.8 T		<b>F5-1004</b>	
Alternator Freewheel Clutch	1.9 SDI, 1.9 TDI		<b>F5-1009</b>	
Anti-Friction Bearing	All Models		<b>F8-3039</b>	H=14; d1=14; D=45
Top Strut Mounting	1.4, 1.4 16V, 1.6, 1.8 T, 1.8 T 4x4, 1.9 SDI, 1.9 TDI, 2.0, RS 1.8 T		<b>F8-4067</b>	H=53; d=26; D=82
Top Strut Mounting	1.6, 1.8, 1.9 TDI	01/1997 →;	<b>F8-4067</b>	H=53; d=26; D=82
Stabiliser Mounting	1.4, 1.6, 1.8, 1.9 SDI, 1.9 TDI, RS 1.8 T	only in connection with: F8-6579; Stabi. Diam. [mm]= 21	<b>F8-5221</b>	d=19
Mounting, axle beam	1.4, 1.4 16V, 1.6, 1.8, 1.8 T, 1.9 SDI, 1.9 TDI, 2.0, RS 1.8 T		<b>F8-5340</b>	H=90; d=12; D=72
Top Strut Mounting	1.4, 1.4 16V, 1.6, 1.8, 1.8 T, 1.9 SDI, 1.9 TDI, 2.0, RS 1.8 T		<b>F8-5380</b>	

<b>AK-732516</b>	<b>AK-735039</b>	<b>AK-735065</b>	<b>AK-735095</b>	<b>AK-735410</b>	<b>F5-1004</b>	<b>F5-1007</b>
Ref.Nr.:	Ref.Nr.: 357413175A	Ref.Nr.: 6U0413175	Ref.Nr.: 1J0512131B	Ref.Nr.: 1J0412303	Ref.Nr.: 038903119T	Ref.Nr.: 028903119AQ
<b>F5-1009</b>	<b>F5-1010</b>	<b>F8-3039</b>	<b>F8-4067</b>	<b>F8-5221</b>	<b>F8-5290</b>	<b>F8-5291</b>
Ref.Nr.: 038903119	Ref.Nr.: 028903119S	Ref.Nr.: 357412249A	Ref.Nr.: 1J0412331B	Ref.Nr.: 1J0411314R	Ref.Nr.: 007296379	Ref.Nr.: 007296377
<b>F8-5340</b>	<b>F8-5380</b>	<b>F8-5550</b>	<b>F8-5993</b>	<b>F8-6345</b>	<b>F8-6398</b>	<b>F8-6695</b>
Ref.Nr.: 6R0501541A	Ref.Nr.: 1J0513353G	Ref.Nr.: 6U0412355	Ref.Nr.: 357412303F	Ref.Nr.: 6U0512335S	Ref.Nr.: 028 105 243AC	Ref.Nr.: 6U0411315



**Article Description****Article Nr.****Fitting Position**

<b>OCTAVIA (1U2)</b>		<b>09/1996 → 12/2010</b>	
Top Strut Mounting	1.8 T 4x4, 1.9 TDI		<b>F8-5380</b>
Rubber Buffer, suspension	All Models		<b>F8-5381</b> H=37; D=76
Engine Mounting	1.9 SDI		<b>F8-5384</b>
Mounting, manual transmission	1.4 16V, 1.6		<b>F8-5385</b>
Engine Mounting	1.4 16V, 1.6, 1.8, 1.8 T, 1.9 TDI, 2.0		<b>F8-5386</b>
Mounting, automatic transmission	1.8		<b>F8-5387</b>
Mounting, automatic transmission	1.8 T	ARZ;	<b>F8-5387</b>
Mounting, automatic transmission	1.8 T 4x4	ARX;  4-speed	<b>F8-5387</b>
Mounting, automatic transmission	1.9 TDI	01/2001 →;  AGR;  4-speed	<b>F8-5387</b>
Mounting, automatic transmission	1.9 TDI	01/2001 →;  AHF;  4-speed	<b>F8-5387</b>
Mounting, automatic transmission	2.0	01/2001 →;  AEG;  4-speed	<b>F8-5387</b>
Engine Mounting	1.4 16V		<b>F8-5388</b>
Engine Mounting	1.6		<b>F8-5390</b>
Spring Cap	All Models		<b>F8-5580</b> D=92
Belt Pulley, crankshaft	1.8, 1.8 T, 1.8 T 4x4, 2.0, RS 1.8 T		<b>F8-5650</b>
Protective Cap/Bellow, shock absorber	All Models		<b>F8-5683</b> H=210
Mounting, axle beam	All Models		<b>F8-5907</b> H=31; d1=18; d2=19; D1=65; D2=56
Rubber Buffer, suspension	1.4, 1.4 16V, 1.6, 1.8, 1.8 T, 1.8 T 4x4, 1.9 SDI, 1.9 TDI, 2.0, RS 1.8 T		<b>F8-5993</b> H=83
Rubber Buffer, suspension	1.4, 1.4 16V, 1.6, 1.8, 1.8 T, 1.9 SDI, 1.9 TDI, 2.0, RS 1.8 T	<b>ST</b>	<b>F8-5996</b> H=63
Rubber Buffer, suspension	1.8 T 4x4	for OE: G07;	<b>F8-5996</b> H=63
Rubber Buffer, suspension	RS 1.8 T	<b>SP</b>	<b>F8-6007</b> H=116
Rubber Buffer, suspension	1.4, 1.4 16V, 1.6, 1.8, 1.8 T, 1.8 T 4x4, 1.9 SDI, 1.9 TDI, 2.0, RS 1.8 T		<b>F8-6012</b> H=143
Rubber Buffer, suspension	1.4, 1.4 16V, 1.6, 1.8, 1.8 T, 1.9 SDI, 1.9 TDI, 2.0, RS 1.8 T		<b>F8-6013</b> H=128
Rubber Buffer, suspension	1.4, 1.4 16V, 1.6, 1.8, 1.8 T, 1.8 T 4x4, 1.9 SDI, 1.9 TDI, 2.0, RS 1.8 T	<b>SP</b>	<b>F8-6041</b> H=53
Rubber Buffer, suspension	1.6, 1.9 TDI	for OE: G85; <b>SP</b>	<b>F8-6041</b> H=53
Protective Cap/Bellow, shock absorber	1.4, 1.4 16V, 1.6, 1.8, 1.8 T, 1.9 SDI, 1.9 TDI, 2.0, RS 1.8 T	ch.→1UW084581	<b>F8-6044</b> H=160
Protective Cap/Bellow, shock absorber	1.4, 1.4 16V, 1.6, 1.8, 1.8 T, 1.9 SDI, 1.9 TDI, 2.0, RS 1.8 T	ch.1U-W-084 581→	<b>F8-6045</b>

<b>F8-5380</b>	<b>F8-5381</b>	<b>F8-5384</b>	<b>F8-5385</b>	<b>F8-5386</b>	<b>F8-5387</b>	<b>F8-5388</b>
Ref.Nr.: 1J0513353G	Ref.Nr.: 1J0512149B	Ref.Nr.: 1J0199555AL	Ref.Nr.: 1J0199555AK	Ref.Nr.: 1J0199555AJ	Ref.Nr.: 1J0199555AH	Ref.Nr.: 1J0199262BK
<b>F8-5390</b>	<b>F8-5580</b>	<b>F8-5650</b>	<b>F8-5683</b>	<b>F8-5907</b>	<b>F8-5993</b>	<b>F8-5996</b>
Ref.Nr.: 1J0199262BE	Ref.Nr.: 1J0412341	Ref.Nr.: 06A105243E	Ref.Nr.: 357413175A	Ref.Nr.: 1J0199429	Ref.Nr.: 357412303F	Ref.Nr.: 1H0412303B
<b>F8-6007</b>	<b>F8-6012</b>	<b>F8-6013</b>	<b>F8-6041</b>	<b>F8-6044</b>	<b>F8-6045</b>	<b>F8-6076</b>
Ref.Nr.: 1J0512131C	Ref.Nr.: 1J0512131	Ref.Nr.: 1J0412131B	Ref.Nr.: 1J0412303	Ref.Nr.: 3C0513425	Ref.Nr.: 1J0513425A	Ref.Nr.: 1J0501541D

Article Description



Article Nr.

Fitting Position



## OCTAVIA (1U2)

09/1996 → 12/2010

Mounting, axle beam	1.4, 1.4 16V, 1.6, 1.8, 1.8 T, 1.9 SDI, 1.9 TDI, 2.0, RS 1.8 T		<b>F8-6076</b>		d=12; L=90; D=69
Repair Set, axle beam	1.4, 1.4 16V, 1.6, 1.8, 1.9 SDI, 1.9 TDI, 2.0, RS 1.8 T		<b>F8-6077</b>		H=90; D=69
Repair Set, axle beam	1.8 T	ARX	<b>F8-6077</b>		H=90; D=69
Top Strut Mounting	1.4, 1.4 16V, 1.6, 1.8 T, 1.8 T 4x4, 1.9 SDI, 1.9 TDI, 2.0, RS 1.8 T		<b>F8-6280</b>		H=53; d=26; D=82
Top Strut Mounting	1.6, 1.8, 1.9 TDI	01/1997 →;	<b>F8-6280</b>		H=53; d=26; D=82
Belt Pulley, crankshaft	1.9 TDI	Number of Ribs: 5; Parameter: 6PK	<b>F8-6392</b>		H=47; d=30; D=143
Belt Pulley, crankshaft	1.9 SDI, 1.9 TDI	ch.1U-3-726897, 1U-38684073→; Number of Ribs: 5; Parameter: 6PK	<b>F8-6396</b>		H=41.6; d=30; Mounting points diam.[mm]=7, 8.6; D=139.7
Engine Mounting	1.4 16V		<b>F8-6531</b>		H=117.7; L=165; W=149
Bracket, stabilizer mounting	1.4, 1.4 16V, 1.6, 1.8, 1.9 SDI, 1.9 TDI, 2.0, RS 1.8 T		<b>F8-6579</b>		
Bracket, stabilizer mounting	1.8 T	AGU, ARX, ARZ	<b>F8-6579</b>		
Bracket, stabilizer mounting	1.8 T 4x4	ARX	<b>F8-6579</b>		
Engine Mounting	1.9 TDI		<b>F8-6960</b>		
Mounting, axle bracket	1.8 T 4x4	ARX	<b>F8-7046</b>		H=55; d=16; D=52
Top Strut Mounting	All Models	for OE: 1J0412319C	<b>F8-7133</b>		
Belt Pulley, crankshaft	1.9 SDI	ch.→1U-3-726896, 1U-38684072;  AQM	<b>F8-7864</b>		
Belt Pulley, crankshaft	1.9 TDI	ch.→1U-3-726896, 1U-38684072	<b>F8-7864</b>		
Stabiliser Mounting	All Models	ch.→1U-42-948654, 1U-48-756165, 1U-4A-022800; for OE: 0AR	<b>F8-7901</b>		
Stabiliser Mounting	1.8 T, 1.8 T 4x4, 1.9 TDI, 2.0		<b>F8-7927</b>		d=18
Control Arm-/Trailing Arm Bush	All Models		<b>F8-7978</b>		
Control Arm-/Trailing Arm Bush	1.4, 1.4 16V, 1.6, 1.8 T, 1.8 T 4x4, 1.9 SDI, 1.9 TDI, 2.0, RS 1.8 T		<b>G9-648</b>		H=54; d=12; D1=33; D2=36
Control Arm-/Trailing Arm Bush	1.6, 1.8, 1.9 TDI	01/1997 →	<b>G9-648</b>		H=54; d=12; D1=33; D2=36
Control Arm-/Trailing Arm Bush	1.4, 1.4 16V, 1.6, 1.8 T, 1.8 T 4x4, 1.9 SDI, 1.9 TDI, 2.0, RS 1.8 T		<b>G9-649</b>		H1=25; H2=41; d=13; D=60
Control Arm-/Trailing Arm Bush	1.6, 1.8, 1.9 TDI	01/1997 →	<b>G9-649</b>		H1=25; H2=41; d=13; D=60
Bellow, steering	All Models	with clamps;	<b>LM-10020S</b>		d1=16; d2=48; L [mm]=179

## OCTAVIA Combi (1U5)

07/1998 → 12/2010

Dust Cover Kit, shock absorber	All Models		<b>AK-735039</b>		
Dust Cover Kit, shock absorber	All Models		<b>AK-735095</b>		
Dust Cover Kit, shock absorber	All Models		<b>AK-735410</b>		H=210
Alternator Freewheel Clutch	1.6, 1.8 T, 1.8 T 4x4, 1.9 SDI, 1.9 TDI, 1.9 TDI 4x4, 2.0, 2.0 4x4, RS 1.8 T		<b>F5-1004</b>		

<b>AK-735039</b>	<b>AK-735095</b>	<b>AK-735410</b>	<b>F5-1004</b>	<b>F5-1009</b>	<b>F8-6076</b>	<b>F8-6077</b>
Ref.Nr.: 357413175A	Ref.Nr.: 1J0512131B	Ref.Nr.: 1J0412303	Ref.Nr.: 038903119T	Ref.Nr.: 038903119	Ref.Nr.: 1J0501541D	Ref.Nr.: 1J0501541DS
<b>F8-6280</b>	<b>F8-6392</b>	<b>F8-6396</b>	<b>F8-6531</b>	<b>F8-6579</b>	<b>F8-6960</b>	<b>F8-7046</b>
Ref.Nr.: 6R0412249	Ref.Nr.: 038105243	Ref.Nr.: 03G105243	Ref.Nr.: 1K0199262T	Ref.Nr.: 1J0 411 336 C	Ref.Nr.: 1J0199262P	Ref.Nr.: 1J0505145B
<b>F8-7133</b>	<b>F8-7864</b>	<b>F8-7901</b>	<b>F8-7927</b>	<b>F8-7978</b>	<b>G9-648</b>	<b>G9-649</b>
Ref.Nr.: 1J0412319C	Ref.Nr.: 038 105 243	Ref.Nr.: 1J0411314P	Ref.Nr.: 1J0411314AC	Ref.Nr.: 357407182F	Ref.Nr.: 357407182	Ref.Nr.: 1J0407181

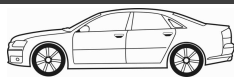
**Article Description****Article Nr.****Fitting Position**

<b>OCTAVIA Combi (1U5)</b>		<b>07/1998 → 12/2010</b>	
Alternator Freewheel Clutch	1.9 SDI, 1.9 TDI, 1.9 TDI 4x4		<b>F5-1009</b>
Anti-Friction Bearing	All Models		<b>F8-3039</b>
Top Strut Mounting	All Models		<b>F8-4067</b>
Stabiliser Mounting	1.4 16V, 1.6, 1.8 20V, 1.8 T, 1.9 SDI, 1.9 TDI, 1.9 TDI 4x4, 2.0 4x4, RS 1.8 T	only in connection with: F8-6579; Stabi. Diam. [mm]= 19	<b>F8-5215</b>
Stabiliser Mounting	1.8 T 4x4	ARX; only in connection with: F8-6579; Stabi. Diam. [mm]= 19	<b>F8-5215</b>
Stabiliser Mounting	1.9 TDI	AGR; only in connection with: F8-6579; Stabi. Diam. [mm]= 19	<b>F8-5215</b>
Stabiliser Mounting	2.0	AQY, AZH; only in connection with: F8-6579; Stabi. Diam. [mm]= 19	<b>F8-5215</b>
Stabiliser Mounting	2.0 4x4	AZJ; only in connection with: F8-6579; Stabi. Diam. [mm]= 19	<b>F8-5215</b>
Stabiliser Mounting	1.6, 1.8 20V, 1.9 TDI, RS 1.8 T	only in connection with: F8-6579; Stabi. Diam. [mm]= 21	<b>F8-5221</b>
Mounting, axle beam	1.6, 1.8 20V, 1.8 T, 1.9 SDI, 1.9 TDI, 1.9 TDI 4x4, 2.0		<b>F8-5340</b>
Top Strut Mounting	1.4 16V, 1.6, 1.8 20V, 1.8 T, 1.9 SDI, 1.9 TDI, 2.0, 2.0 4x4		<b>F8-5380</b>
Top Strut Mounting	1.8 T 4x4, 1.9 TDI, 1.9 TDI 4x4, 2.0 4x4, RS 1.8 T		<b>F8-5380</b>
Rubber Buffer, suspension	All Models		<b>F8-5381</b>
Engine Mounting	1.9 SDI		<b>F8-5384</b>
Mounting, manual transmission	1.4 16V, 1.6		<b>F8-5385</b>
Engine Mounting	1.4 16V, 1.6, 1.8 20V, 1.8 T, 1.9 TDI, 2.0		<b>F8-5386</b>
Mounting, automatic transmission	1.8 20V		<b>F8-5387</b>
Mounting, automatic transmission	1.8 T	01/2001 →;  AUM;  4-speed	<b>F8-5387</b>
Mounting, automatic transmission	1.8 T 4x4	ARX;  4-speed	<b>F8-5387</b>
Mounting, automatic transmission	1.9 TDI	01/2001 →;  AGR;  4-speed	<b>F8-5387</b>
Mounting, automatic transmission	1.9 TDI	01/2001 →;  AHF;  4-speed	<b>F8-5387</b>
Mounting, automatic transmission	1.9 TDI 4x4		<b>F8-5387</b>
Mounting, automatic transmission	2.0	01/2001 →;  AEG;  4-speed	<b>F8-5387</b>
Mounting, automatic transmission	2.0 4x4	AZH;  4-speed	<b>F8-5387</b>
Engine Mounting	1.4 16V		<b>F8-5388</b>
Engine Mounting	1.6		<b>F8-5390</b>
Spring Cap	All Models		<b>F8-5580</b>

<b>F5-1009</b>	<b>F8-3039</b>	<b>F8-4067</b>	<b>F8-5215</b>	<b>F8-5221</b>	<b>F8-5340</b>	<b>F8-5380</b>
Ref.Nr.: 038903119	Ref.Nr.: 357412249A	Ref.Nr.: 1J0412331B	Ref.Nr.: 1J0411314B	Ref.Nr.: 1J0411314R	Ref.Nr.: 6R0501541A	Ref.Nr.: 1J0513353G
<b>F8-5381</b>	<b>F8-5384</b>	<b>F8-5385</b>	<b>F8-5386</b>	<b>F8-5387</b>	<b>F8-5388</b>	<b>F8-5390</b>
Ref.Nr.: 1J0512149B	Ref.Nr.: 1J0199555AL	Ref.Nr.: 1J0199555AK	Ref.Nr.: 1J0199555AJ	Ref.Nr.: 1J0199555AH	Ref.Nr.: 1J0199262BK	Ref.Nr.: 1J0199262BE
<b>F8-5580</b>	<b>F8-5650</b>					
Ref.Nr.: 1J0412341	Ref.Nr.: 06A105243E					

Article Description



Article Nr.

Fitting Position



<b>OCTAVIA Combi (1U5)</b>			<b>07/1998 → 12/2010</b>	
Belt Pulley, crankshaft	1.8 20V, 1.8 T, 1.8 T 4x4, 2.0, 2.0 4x4, RS 1.8 T		<b>F8-5650</b>	
Protective Cap/Bellow, shock absorber	All Models		<b>F8-5683</b>	H=210
Mounting, axle beam	1.4 16V, 1.6, 1.8 20V, 1.8 T, 1.8 T 4x4, 1.9 SDI, 1.9 TDI, 1.9 TDI 4x4, 2.0, 2.0 4x4, RS 1.8 T		<b>F8-5907</b>	H=31; d1=18; d2=19; D1=65; D2=56
Mounting, axle beam	1.9 TDI	AXR	<b>F8-5907</b>	H=31; d1=18; d2=19; D1=65; D2=56
Rubber Buffer, suspension	1.4 16V, 1.6, 1.8 20V, 1.8 T, 1.8 T 4x4, 1.9 SDI, 1.9 TDI, 1.9 TDI 4x4, 2.0, 2.0 4x4, RS 1.8 T		<b>F8-5993</b>	H=83
Rubber Buffer, suspension	1.4 16V, 1.6, 1.8 20V, 1.8 T, 1.9 SDI, 1.9 TDI, 2.0, 2.0 4x4, RS 1.8 T	<b>ST</b>	<b>F8-5996</b>	H=63
Rubber Buffer, suspension	1.8 T 4x4, 1.9 TDI 4x4	for OE: G07;	<b>F8-5996</b>	H=63
Rubber Buffer, suspension	1.4 16V, 1.6, 1.8 20V, 1.8 T, 1.8 T 4x4, 1.9 SDI, 1.9 TDI, 1.9 TDI 4x4, 2.0, 2.0 4x4, RS 1.8 T		<b>F8-6012</b>	H=143
Top Strut Mounting	All Models	ch. 1U-2-559801, 1U-28541901→	<b>F8-6040</b>	
Rubber Buffer, suspension	1.4 16V, 1.6, 1.8 20V, 1.8 T, 1.8 T 4x4, 1.9 SDI, 1.9 TDI, 1.9 TDI 4x4, 2.0, 2.0 4x4, RS 1.8 T	<b>SP</b>	<b>F8-6041</b>	H=53
Rubber Buffer, suspension	1.6, 1.9 TDI	for OE: G85; <b>SP</b>	<b>F8-6041</b>	H=53
Protective Cap/Bellow, shock absorber	1.4 16V, 1.6, 1.8 20V, 1.8 T, 1.9 SDI, 1.9 TDI, 2.0, RS 1.8 T		<b>F8-6044</b>	H=160
Mounting, axle beam	1.4 16V, 1.6, 1.8 20V, 1.8 T, 1.9 SDI, 1.9 TDI, 2.0, RS 1.8 T		<b>F8-6076</b>	d=12; L=90; D=69
Repair Set, axle beam	1.4 16V, 1.6, 1.8 20V, 1.8 T, 1.9 SDI, 1.9 TDI, RS 1.8 T		<b>F8-6077</b>	H=90; D=69
Repair Set, axle beam	1.9 TDI	AXR	<b>F8-6077</b>	H=90; D=69
Repair Set, axle beam	2.0	AZJ	<b>F8-6077</b>	H=90; D=69
Top Strut Mounting	All Models		<b>F8-6280</b>	H=53; d=26; D=82
Belt Pulley, crankshaft	1.9 TDI, 1.9 TDI 4x4	Number of Ribs: 5; Parameter: 6PK	<b>F8-6392</b>	H=47; d=30; D=143
Belt Pulley, crankshaft	1.9 SDI, 1.9 TDI	ch. 1U-3-726897, 1U-38684073→; Number of Ribs: 5; Parameter: 6PK	<b>F8-6396</b>	H=41.6; d=30; Mounting points diam.[mm]=7, 8.6; D=139.7
Engine Mounting	1.4 16V		<b>F8-6531</b>	H=117.7; L=165; W=149
Bracket, stabilizer mounting	1.4 16V, 1.6, 1.8 20V, 1.8 T, 1.9 SDI, 1.9 TDI, 1.9 TDI 4x4, 2.0 4x4, RS 1.8 T		<b>F8-6579</b>	
Bracket, stabilizer mounting	1.8 T 4x4	ARX	<b>F8-6579</b>	
Bracket, stabilizer mounting	2.0	AEG, APK, AQY, AZJ	<b>F8-6579</b>	
Bracket, stabilizer mounting	2.0 4x4	AZH	<b>F8-6579</b>	
Engine Mounting	1.9 TDI		<b>F8-6960</b>	
Mounting, axle bracket	1.8 T 4x4	ARX	<b>F8-7046</b>	H=55; d=16; D=52
Mounting, axle bracket	1.9 TDI 4x4, 2.0 4x4		<b>F8-7046</b>	H=55; d=16; D=52
Mounting, axle bracket	2.0 4x4	AZH	<b>F8-7046</b>	H=55; d=16; D=52
Top Strut Mounting	All Models	for OE: 1J0412319C	<b>F8-7133</b>	

<b>F8-5650</b>	<b>F8-5683</b>	<b>F8-5907</b>	<b>F8-5993</b>	<b>F8-5996</b>	<b>F8-6012</b>	<b>F8-6040</b>
Ref.Nr.: 06A105243E	Ref.Nr.: 357413175A	Ref.Nr.: 1J0199429	Ref.Nr.: 357412303F	Ref.Nr.: 1H0412303B	Ref.Nr.: 1J0512131	Ref.Nr.: 1J0513353D
<b>F8-6041</b>	<b>F8-6044</b>	<b>F8-6076</b>	<b>F8-6077</b>	<b>F8-6280</b>	<b>F8-6392</b>	<b>F8-6396</b>
Ref.Nr.: 1J0412303	Ref.Nr.: 3C0513425	Ref.Nr.: 1J0501541D	Ref.Nr.: 1J0501541DS	Ref.Nr.: 6R0412249	Ref.Nr.: 038105243	Ref.Nr.: 03G105243
<b>F8-6531</b>	<b>F8-6579</b>	<b>F8-6960</b>	<b>F8-7046</b>	<b>F8-7133</b>	<b>F8-7864</b>	
Ref.Nr.: 1K0199262T	Ref.Nr.: 1J0 411 336 C	Ref.Nr.: 1J0199262P	Ref.Nr.: 1J0505145B	Ref.Nr.: 1J0412319C	Ref.Nr.: 038 105 243	

**Article Description****Article Nr.****Fitting Position**

<b>OCTAVIA Combi (1U5)</b>			<b>07/1998 → 12/2010</b>		
Belt Pulley, crankshaft	1.9 SDI	ch.→1U-3-726896, 1U-38684072;  AQM	<b>F8-7864</b>		
Belt Pulley, crankshaft	1.9 TDI, 1.9 TDI 4x4	ch.→1U-3-726896, 1U-38684072	<b>F8-7864</b>		
Stabiliser Mounting	1.4 16V, 1.6, 1.8 20V, 1.8 T, 1.8 T 4x4, 1.9 SDI, 1.9 TDI, 1.9 TDI 4x4, 2.0 4x4, RS 1.8 T	ch.→1U-42-948654, 1U-48-756165, 1U-4A-022800; for OE: 0AR	<b>F8-7901</b>		
Stabiliser Mounting	1.9 TDI	ch.→1U-42-948654, 1U-48-756165, 1U-4A-022800;  AXR; for OE: 0AR	<b>F8-7901</b>		
Stabiliser Mounting	2.0	ch.→1U-42-948654, 1U-48-756165, 1U-4A-022800;  AEG; for OE: 0AR	<b>F8-7901</b>		
Stabiliser Mounting	2.0	ch.→1U-42-948654, 1U-48-756165, 1U-4A-022800;  APK; for OE: 0AR	<b>F8-7901</b>		
Stabiliser Mounting	2.0	ch.→1U-42-948654, 1U-48-756165, 1U-4A-022800;  AQY; for OE: 0AR	<b>F8-7901</b>		
Stabiliser Mounting	2.0	ch.→1U-42-948654, 1U-48-756165, 1U-4A-022800;  AZJ; for OE: 0AR	<b>F8-7901</b>		
Stabiliser Mounting	1.8 T, 1.8 T 4x4, 1.9 TDI, 1.9 TDI 4x4, 2.0, 2.0 4x4		<b>F8-7927</b>		d=18
Control Arm-/Trailing Arm Bush	All Models		<b>F8-7978</b>		
Control Arm-/Trailing Arm Bush	1.4 16V, 1.6, 1.8 20V, 1.8 T, 1.8 T 4x4, 1.9 SDI, 1.9 TDI, 1.9 TDI 4x4, 2.0, 2.0 4x4, RS 1.8 T		<b>G9-648</b>		H=54; d=12; D1=33; D2=36
Control Arm-/Trailing Arm Bush	1.4 16V, 1.6, 1.8 20V, 1.8 T, 1.8 T 4x4, 1.9 SDI, 1.9 TDI, 1.9 TDI 4x4, 2.0, 2.0 4x4, RS 1.8 T		<b>G9-649</b>		H1=25; H2=41; d=13; D=60
Bellow, steering	All Models	with clamps;	<b>LM-10020S</b>		d1=16; d2=48; L [mm]=179
<b>OCTAVIA (1Z3)</b>			<b>02/2004 → 06/2013</b>		
Dust Cover Kit, shock absorber	1.4, 1.6, 1.6 FSI, 1.9 TDI, 2.0 FSI, 2.0 TDI, 2.0 TDI 16V		<b>AK-735172</b>		
Dust Cover Kit, shock absorber	1.4, 1.6, 1.6 FSI, 1.9 TDI, 2.0 FSI, 2.0 RS, 2.0 TDI, 2.0 TDI 16V		<b>AK-735175</b>		
Alternator Freewheel Clutch	1.6, 1.6 MultiFuel, 1.6 TDI, 1.9 TDI, 2.0 FSI, 2.0 RS, 2.0 TDI, 2.0 TDI 16V, 2.0 TDI RS		<b>F5-1004</b>		
Alternator Freewheel Clutch	1.8 TSI, 2.0 RS		<b>F5-1044</b>		
Alternator Freewheel Clutch	1.2 TSI, 1.4 TSI		<b>F5-1064</b>		
Spring Cap	1.4, 1.6, 1.6 FSI, 1.8 TSI, 1.9 TDI, 2.0 FSI, 2.0 RS, 2.0 TDI, 2.0 TDI 16V, 2.0 TDI RS		<b>F8-5580</b>		D=92
Control Arm-/Trailing Arm Bush	All Models		<b>F8-5633</b>		
Belt Pulley, crankshaft	2.0 FSI, 2.0 RS		<b>F8-5650</b>		
Protective Cap/Bellow, shock absorber	1.4, 1.6, 1.6 FSI, 1.9 TDI, 2.0 FSI, 2.0 RS, 2.0 TDI, 2.0 TDI 16V		<b>F8-6044</b>		H=160
Protective Cap/Bellow, shock absorber	2.0 TDI		<b>F8-6044</b>		H=160
Mounting, axle beam	1.4, 1.6, 1.6 FSI, 1.9 TDI, 2.0 FSI, 2.0 RS, 2.0 TDI, 2.0 TDI 16V		<b>F8-6076</b>		d=12; L=90; D=69
Repair Set, axle beam	1.4, 1.6 FSI, 2.0 TDI, 2.0 TDI 16V		<b>F8-6077</b>		H=90; D=69

<b>AK-735172</b>	<b>AK-735175</b>	<b>F5-1004</b>	<b>F5-1044</b>	<b>F5-1064</b>	<b>F8-5580</b>	<b>F8-5633</b>
Ref.Nr.: 1K0511353M	Ref.Nr.: 1K0412303B	Ref.Nr.: 038903119T	Ref.Nr.: 06B903119B	Ref.Nr.: 03C903119D	Ref.Nr.: 1J0412341	Ref.Nr.: 1K0407182A
<b>F8-5650</b>	<b>F8-6044</b>	<b>F8-6076</b>	<b>F8-6077</b>	<b>F8-7864</b>	<b>F8-7901</b>	<b>F8-7927</b>
Ref.Nr.: 06A105243E	Ref.Nr.: 3C0513425	Ref.Nr.: 1J0501541D	Ref.Nr.: 1J0501541DS	Ref.Nr.: 038 105 243	Ref.Nr.: 1J0411314P	Ref.Nr.: 1J0411314AC
<b>F8-7978</b>	<b>G9-648</b>	<b>G9-649</b>	<b>LM-10020S</b>			
Ref.Nr.: 357407182F	Ref.Nr.: 357407182	Ref.Nr.: 1J0407181	Ref.Nr.: 1J0422831B			

Article Description



Article Nr.

Fitting Position



OCTAVIA (1Z3)		02/2004 → 06/2013			
Repair Set, axle beam	1.6	BSE	F8-6077		H=90; D=69
Repair Set, axle beam	1.9 TDI	BLS	F8-6077		H=90; D=69
Repair Set, axle beam	2.0 FSI	BVZ	F8-6077		H=90; D=69
Repair Set, axle beam	2.0 RS	BWA	F8-6077		H=90; D=69
Top Strut Mounting	All Models		F8-6284		
Top Strut Mounting	1.4, 1.6, 1.6 FSI, 1.8 TSI, 1.9 TDI, 2.0 FSI, 2.0 RS, 2.0 TDI, 2.0 TDI 16V, 2.0 TDI RS	for OE: 1K0 513 353 J; Shape Oval	F8-6350		
Belt Pulley, crankshaft	1.9 TDI, 2.0 TDI 16V	ch. 1Z-4-000001→; Number of Ribs: 5; Parameter: 6PK	F8-6396		H=41.6; d=30; Mounting points diam.[mm]=7, 8.6; D=139.7
Belt Pulley, crankshaft	2.0 TDI	Number of Ribs: 5; Parameter: 6PK	F8-6396		H=41.6; d=30; Mounting points diam.[mm]=7, 8.6; D=139.7
Control Arm-/Trailing Arm Bush	1.4, 1.4 TSI, 1.6, 1.6 FSI, 1.6 MultiFuel, 1.6 TDI, 1.8 TSI, 1.9 TDI, 2.0 FSI, 2.0 RS, 2.0 TDI, 2.0 TDI 16V, 2.0 TDI RS	Aluminium	F8-6424		
Control Arm-/Trailing Arm Bush	1.4, 1.4 TSI, 1.6, 1.6 FSI, 1.6 MultiFuel, 1.6 TDI, 1.8 TSI, 1.9 TDI, 2.0 FSI, 2.0 RS, 2.0 TDI, 2.0 TDI 16V, 2.0 TDI RS	Aluminium	F8-6425		
Control Arm-/Trailing Arm Bush	1.4, 1.4 TSI, 1.6, 1.6 FSI, 1.6 MultiFuel, 1.6 TDI, 1.8 TSI, 1.9 TDI, 2.0 FSI, 2.0 RS, 2.0 TDI, 2.0 TDI 16V, 2.0 TDI RS		F8-6463		H=64; d=12; D=60
Engine Mounting	2.0 TDI RS	BMN	F8-6528		
Engine Mounting	2.0 TDI, 2.0 TDI 16V		F8-6528		
Engine Mounting	1.4, 1.6 FSI		F8-6531		H=117.7; L=165; W=149
Anti-Friction Bearing	All Models		F8-6569		
Top Strut Mounting	All Models		F8-6570		
Belt Pulley, crankshaft	1.6 TDI	ch. 1Z-9A153727, 1Z-A2057742, 1Z-A8021762, 1Z-AC009082, 1Z-AD150036, 1Z-AK151667→; Number of Ribs: 5; Parameter: 6PK	F8-6572		
Belt Pulley, crankshaft	2.0 TDI	CFHF, CLCA; Number of Ribs: 5; Parameter: 6PK	F8-6572		
Belt Pulley, crankshaft	2.0 TDI 16V	CFHC, CLCB; Number of Ribs: 5; Parameter: 6PK	F8-6572		
Bracket, stabilizer mounting	1.4, 1.6, 1.6 FSI, 1.8 TSI, 2.0 RS, 2.0 TDI, 2.0 TDI 16V, 2.0 TDI RS		F8-6579		
Bracket, stabilizer mounting	1.9 TDI	BJB, BKC	F8-6579		
Bracket, stabilizer mounting	2.0 FSI	BLR, BLY	F8-6579		
Engine Mounting	1.6	ch. 1Z-4-000001→	F8-6988		
Engine Mounting	1.8 TSI, 2.0 FSI, 2.0 RS		F8-6989		
Engine Mounting	1.6 FSI	ch. 1Z-5-016012, 1Z-58030446→;	F8-6991		

<b>F8-6077</b>	<b>F8-6284</b>	<b>F8-6350</b>	<b>F8-6396</b>	<b>F8-6424</b>	<b>F8-6425</b>	<b>F8-6463</b>
Ref.Nr.: 1J0501541DS	Ref.Nr.: 6N0412249C	Ref.Nr.: 1K0513353J	Ref.Nr.: 03G105243	Ref.Nr.: 1K0199232G	Ref.Nr.: 1K0199231J	Ref.Nr.: 1K0505541B
<b>F8-6528</b>	<b>F8-6531</b>	<b>F8-6569</b>	<b>F8-6570</b>	<b>F8-6572</b>	<b>F8-6579</b>	<b>F8-6988</b>
Ref.Nr.: 1K0 199 262 AT	Ref.Nr.: 1K0199262T	Ref.Nr.: 6N0412249C	Ref.Nr.: 1K0412331C	Ref.Nr.: 038105243L	Ref.Nr.: 1J0 411 336 C	Ref.Nr.: 1K0199262AL
<b>F8-6989</b>	<b>F8-6991</b>	<b>F8-7131</b>				
Ref.Nr.: 1K0199262AM	Ref.Nr.: 1K0199262AK	Ref.Nr.: 1K0412303B				

**Article Description****Article Nr.****Fitting Position**

<b>OCTAVIA (1Z3)</b>		<b>02/2004 → 06/2013</b>	
Rubber Buffer, suspension	1.2 TSI, 1.4, 1.4 TSI, 1.6, 1.6 FSI, 1.6 LPG, 1.6 MultiFuel, 1.6 TDI, 1.8 TSI, 1.9 TDI, 2.0 FSI, 2.0 TDI, 2.0 TDI 16V, 2.0 TDI RS	for OE: 2UA, G02, G07;	<b>F8-7131</b>
Protective Cap/Bellow, shock absorber	All Models		<b>F8-7132</b>
Rubber Buffer, suspension	All Models	for OE: 1JA, 1JB; ,	<b>F8-7140</b>
Rubber Buffer, suspension	1.4, 1.6, 1.6 FSI, 1.9 TDI, 2.0 TDI 16V	,	<b>F8-7600</b>
Top Strut Mounting	1.4, 1.6, 1.6 FSI, 1.8 TSI, 1.9 TDI, 2.0 FSI, 2.0 RS, 2.0 TDI, 2.0 TDI 16V, 2.0 TDI RS	for OE: 3C0513353C; Shape Round	<b>F8-7603</b>
Rubber Buffer, suspension	All Models	for OE: 2UC, G07;	<b>F8-7697</b>
Rubber Buffer, suspension	All Models	for OE: 2UB, G02;	<b>F8-7703</b>
Rubber Buffer, suspension	1.2 TSI, 1.4 TSI, 1.6 LPG, 1.6 MultiFuel, 1.6 TDI, 1.8 TSI, 2.0 TDI	for OE: 1JC;	<b>F8-7714</b>
Rubber Buffer, suspension	1.4, 1.6, 1.6 FSI, 1.9 TDI, 2.0 FSI, 2.0 TDI, 2.0 TDI 16V	05/2006 →; for OE: 1JC;	<b>F8-7714</b>
Rubber Buffer, suspension	2.0 RS	05/2006 →; for OE: 1JS;	<b>F8-7714</b>
Rubber Buffer, suspension	2.0 TDI RS	for OE: 1JS;	<b>F8-7714</b>
Rubber Buffer, suspension	All Models	for OE: 2UC, G02;	<b>F8-7809</b>
Rubber Buffer, suspension	All Models	for OE: 2UB, G07;	<b>F8-7834</b>
Control Arm-/Trailing Arm Bush	1.4	ch. 1Z-8A156314, 1Z-92008800, 1Z-98006050, 1Z-9B150000, 1Z-9C003000, 1Z-9D015004, 1Z-9K150000→; 11/2008 →; TOUR	<b>F8-7856</b>
Control Arm-/Trailing Arm Bush	1.6	ch. 1Z-8A156314, 1Z-92008800, 1Z-98006050, 1Z-9B150000, 1Z-9C003000, 1Z-9D015004, 1Z-9K150000→; 11/2008 →;  BSE, BSF, CMXA; TOUR; not for  BGU, CCSA	<b>F8-7856</b>
Control Arm-/Trailing Arm Bush	1.9 TDI	ch. 1Z-8A156314, 1Z-92008800, 1Z-98006050, 1Z-9B150000, 1Z-9C003000, 1Z-9D015004, 1Z-9K150000→; 11/2008 →;  BXE; TOUR; not for  BJB, BKC, BLS	<b>F8-7856</b>
Control Arm-/Trailing Arm Bush	2.0 TDI	ch. 1Z-8A156314, 1Z-92008800, 1Z-98006050, 1Z-9B150000, 1Z-9C003000, 1Z-9D015004, 1Z-9K150000→; 11/2008 →;  CLCA; TOUR; not for  CFHF	<b>F8-7856</b>
Belt Pulley, crankshaft	1.8 TSI, 2.0 RS	Number of Ribs: 5; Parameter: 6PK	<b>F8-7880</b>
Rubber Buffer, suspension	1.4, 1.6, 1.6 FSI, 1.9 TDI, 2.0 FSI, 2.0 TDI, 2.0 TDI 16V	for OE: 1JC; Shape Oval;	<b>F8-7897</b>
Rubber Buffer, suspension	2.0 RS, 2.0 TDI RS	for OE: 1JS; Shape Oval;	<b>F8-7897</b>
Control Arm-/Trailing Arm Bush	All Models		<b>F8-7902</b>
Control Arm-/Trailing Arm Bush	All Models		<b>F8-7907</b>

<b>F8-7131</b>	<b>F8-7132</b>	<b>F8-7140</b>	<b>F8-7600</b>	<b>F8-7603</b>	<b>F8-7697</b>	<b>F8-7703</b>
Ref.Nr.: 1K0412303B	Ref.Nr.: 6N0413175A	Ref.Nr.: 3C0511359	Ref.Nr.: 1K0 511 353 P	Ref.Nr.: 3C0513353	Ref.Nr.: 1K0412303F	Ref.Nr.: 1K0412303G
<b>F8-7714</b>	<b>F8-7809</b>	<b>F8-7834</b>	<b>F8-7856</b>	<b>F8-7880</b>	<b>F8-7897</b>	<b>F8-7902</b>
Ref.Nr.: 3C0511359B	Ref.Nr.: 1K0412303E	Ref.Nr.: 1K0412303H	Ref.Nr.: 5C0407183A	Ref.Nr.: 06H105243F	Ref.Nr.: 1K0511353F	Ref.Nr.: 1K0505171C
<b>F8-7907</b>	<b>F8-7908</b>					
Ref.Nr.: 1K0505203A	Ref.Nr.: 1K0505279A					

Article Description

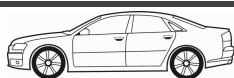

Article Nr.

Fitting Position



<b>OCTAVIA (1Z3)</b>		<b>02/2004 → 06/2013</b>	
Control Arm-/Trailing Arm Bush	All Models	F8-7908	H=45; d=12; D=38
Control Arm-/Trailing Arm Bush	All Models	F8-7909	
Stabiliser Mounting	1.4, 1.6, 1.6 FSI, 1.9 TDI, 2.0 FSI, 2.0 RS, 2.0 TDI, 2.0 TDI 16V	F8-7923	d=20,7
Stabiliser Mounting	1.4, 1.6, 1.6 FSI, 1.9 TDI, 2.0 FSI, 2.0 RS, 2.0 TDI 16V	F8-7930	d=18,5
Engine Mounting	1.9 TDI	F8-7958	
Engine Mounting	1.4, 1.4 TSI, 1.6, 1.6 FSI, 1.6 MultiFuel	F8-7960	
Engine Mounting	1.6	ch.1Z-4-000 001→;  BGU, BSE, BSF	F8-7961
Engine Mounting	1.6 FSI, 2.0 FSI	ch.1Z-4-000 001→	F8-7961
Engine Mounting	1.9 TDI, 2.0 TDI, 2.0 TDI 16V, 2.0 TDI RS		F8-7962
Engine Mounting	2.0 RS	6-speed	F8-7962
Engine Mounting	1.2 TSI, 1.4, 1.6 FSI		F8-7965
Engine Mounting	1.6		F8-7965
Engine Mounting	1.6	BGU;  6-speed	F8-7966
Engine Mounting	1.6	BSE, BSF;  6-speed	F8-7966
Engine Mounting	1.8 TSI, 1.9 TDI, 2.0 FSI, 2.0 RS, 2.0 TDI, 2.0 TDI 16V, 2.0 TDI RS		F8-7966
Engine Mounting	1.8 TSI	BZB	F8-7981
Engine Mounting	1.9 TDI, 2.0 TDI, 2.0 TDI 16V		F8-7981
Engine Mounting	2.0 FSI		F8-7981
Engine Mounting	2.0 RS	BWA	F8-7981
Engine Mounting	1.2 TSI, 1.4, 1.4 TSI, 1.6 FSI, 1.6 MultiFuel, 1.6 TDI, 1.8 TSI, 1.9 TDI, 2.0 RS, 2.0 TDI, 2.0 TDI RS		F8-7982
Engine Mounting	1.6	BGU, BSE, BSF, CCSA	F8-7982
Engine Mounting	2.0 FSI	BLR, BLY	F8-7982
Engine Mounting	2.0 TDI	CLCA	F8-7982
Engine Mounting	2.0 TDI 16V	BKD, CFHC, CLCB	F8-7982
Engine Mounting	2.0 TDI	12/2010 →	F8-8152
Engine Mounting	2.0 TDI, 2.0 TDI 16V, 2.0 TDI RS		F8-8152
<b>OCTAVIA Combi (1Z5)</b>		<b>02/2004 → 06/2013</b>	
Dust Cover Kit, shock absorber	1.4, 1.6, 1.6 FSI, 1.9 TDI, 1.9 TDI 4x4, 2.0 FSI, 2.0 FSI 4x4, 2.0 TDI, 2.0 TDI 16V, 2.0 TDI 4x4	AK-735172	
Dust Cover Kit, shock absorber	1.4, 1.6, 1.6 FSI, 1.9 TDI, 1.9 TDI 4x4, 2.0 FSI, 2.0 FSI 4x4, 2.0 RS, 2.0 TDI, 2.0 TDI 16V, 2.0 TDI 4x4	AK-735175	
Alternator Freewheel Clutch	1.6, 1.6 MultiFuel, 1.6 TDI, 1.6 TDI 4x4, 1.9 TDI, 1.9 TDI 4x4, 2.0 FSI, 2.0 FSI 4x4, 2.0 RS, 2.0 TDI, 2.0 TDI 16V, 2.0 TDI 16V 4x4, 2.0 TDI 4x4, 2.0 TDI RS	F5-1004	

<b>AK-735172</b>	<b>AK-735175</b>	<b>F5-1004</b>	<b>F5-1044</b>	<b>F8-7908</b>	<b>F8-7909</b>	<b>F8-7923</b>
Ref.Nr.: 1K0511353M	Ref.Nr.: 1K0412303B	Ref.Nr.: 038903119T	Ref.Nr.: 06B903119B	Ref.Nr.: 1K0505279A	Ref.Nr.: 1K0505553 A	Ref.Nr.: 1K0511327AR
<b>F8-7930</b>	<b>F8-7958</b>	<b>F8-7960</b>	<b>F8-7961</b>	<b>F8-7962</b>	<b>F8-7965</b>	<b>F8-7966</b>
Ref.Nr.: 1K0511327AP	Ref.Nr.: 1K0199262AS	Ref.Nr.: 1K0199555L	Ref.Nr.: 1K0199555N	Ref.Nr.: 1K0199555Q	Ref.Nr.: 1K0199855BA	Ref.Nr.: 1K0199855BB
<b>F8-7981</b>	<b>F8-7982</b>	<b>F8-8152</b>				
Ref.Nr.: 1K0199867Q	Ref.Nr.: 1K0199868Q	Ref.Nr.: 1K0199555T				



**Article Description****Article Nr.****Fitting Position**

<b>OCTAVIA Combi (1Z5)</b>		<b>02/2004 → 06/2013</b>	
Alternator Freewheel Clutch	1.8 TSI, 1.8 TSI 4x4, 2.0 RS		<b>F5-1044</b>
Alternator Freewheel Clutch	1.2 TSI, 1.4 TSI		<b>F5-1064</b>
Stabiliser Mounting	1.6, 1.6 FSI, 1.9 TDI, 2.0 TDI 16V	only in connection with: F8-6579; Stabi. Diam. [mm]= 19	<b>F8-5215</b>
Spring Cap	1.4, 1.6, 1.6 FSI, 1.8 TSI, 1.9 TDI, 1.9 TDI 4x4, 2.0 FSI, 2.0 FSI 4x4, 2.0 RS, 2.0 TDI, 2.0 TDI 16V, 2.0 TDI 4x4, 2.0 TDI RS		<b>F8-5580</b>
Control Arm-/Trailing Arm Bush	All Models		<b>F8-5633</b>
Belt Pulley, crankshaft	2.0 FSI, 2.0 FSI 4x4, 2.0 RS		<b>F8-5650</b>
Protective Cap/Bellow, shock absorber	1.6, 1.6 FSI, 1.9 TDI, 2.0 FSI, 2.0 FSI 4x4, 2.0 TDI, 2.0 TDI 16V		<b>F8-6044</b>
Protective Cap/Bellow, shock absorber	2.0 RS, 2.0 TDI 16V, 2.0 TDI RS		<b>F8-6044</b>
Mounting, axle beam	1.6, 1.6 FSI, 1.9 TDI, 2.0 FSI, 2.0 FSI 4x4, 2.0 RS, 2.0 TDI, 2.0 TDI 16V		<b>F8-6076</b>
Repair Set, axle beam	1.6	BSE	<b>F8-6077</b>
Repair Set, axle beam	1.6 FSI, 2.0 TDI, 2.0 TDI 16V		<b>F8-6077</b>
Repair Set, axle beam	1.9 TDI	BLS	<b>F8-6077</b>
Repair Set, axle beam	2.0 FSI	BVY	<b>F8-6077</b>
Repair Set, axle beam	2.0 FSI 4x4	BLX	<b>F8-6077</b>
Repair Set, axle beam	2.0 RS	BWA	<b>F8-6077</b>
Top Strut Mounting	1.2 TSI, 1.4, 1.4 TSI, 1.6, 1.6 FSI, 1.6 LPG, 1.6 MultiFuel, 1.6 TDI, 1.6 TDI 4x4, 1.8 TSI, 1.8 TSI 4x4, 1.9 TDI, 1.9 TDI 4x4, 2.0 FSI, 2.0 FSI 4x4, 2.0 RS, 2.0 TDI, 2.0 TDI 16V, 2.0 TDI 16V 4x4, 2.0 TDI 4x4, 2.0 TDI RS		<b>F8-6284</b>
Top Strut Mounting	1.4, 1.6, 1.6 FSI, 1.8 TSI, 1.9 TDI, 1.9 TDI 4x4, 2.0 FSI, 2.0 FSI 4x4, 2.0 RS, 2.0 TDI, 2.0 TDI 16V, 2.0 TDI 4x4, 2.0 TDI RS	for OE: 1K0 513 353 J; Shape Oval	<b>F8-6350</b>
Belt Pulley, crankshaft	1.9 TDI, 2.0 TDI 16V	ch.1Z-4-000001→; Number of Ribs: 5; Parameter: 6PK	<b>F8-6396</b>
Belt Pulley, crankshaft	2.0 TDI, 2.0 TDI 4x4	Number of Ribs: 5; Parameter: 6PK	<b>F8-6396</b>
Control Arm-/Trailing Arm Bush	1.4, 1.4 TSI, 1.6, 1.6 FSI, 1.6 MultiFuel, 1.6 TDI, 1.8 TSI, 1.8 TSI 4x4, 1.9 TDI, 1.9 TDI 4x4, 2.0 FSI, 2.0 FSI 4x4, 2.0 RS, 2.0 TDI, 2.0 TDI 16V, 2.0 TDI 4x4, 2.0 TDI RS	Aluminium	<b>F8-6424</b>
Control Arm-/Trailing Arm Bush	1.4, 1.4 TSI, 1.6, 1.6 FSI, 1.6 MultiFuel, 1.6 TDI, 1.8 TSI, 1.8 TSI 4x4, 1.9 TDI, 1.9 TDI 4x4, 2.0 FSI, 2.0 FSI 4x4, 2.0 RS, 2.0 TDI, 2.0 TDI 16V, 2.0 TDI 4x4, 2.0 TDI RS	Aluminium	<b>F8-6425</b>

<b>F5-1044</b>	<b>F5-1064</b>	<b>F8-5215</b>	<b>F8-5580</b>	<b>F8-5633</b>	<b>F8-5650</b>	<b>F8-6044</b>
Ref.Nr.: 06B903119B	Ref.Nr.: 03C903119D	Ref.Nr.: 1J0411314B	Ref.Nr.: 1J0412341	Ref.Nr.: 1K0407182A	Ref.Nr.: 06A105243E	Ref.Nr.: 3C0513425
<b>F8-6076</b>	<b>F8-6077</b>	<b>F8-6284</b>	<b>F8-6350</b>	<b>F8-6396</b>	<b>F8-6424</b>	<b>F8-6425</b>
Ref.Nr.: 1J0501541D	Ref.Nr.: 1J0501541DS	Ref.Nr.: 6N0412249C	Ref.Nr.: 1K0513353J	Ref.Nr.: 03G105243	Ref.Nr.: 1K0199232G	Ref.Nr.: 1K0199231J
<b>F8-6463</b>						
Ref.Nr.: 1K0505541B						

Article Description



Article Nr.

Fitting Position



<b>OCTAVIA Combi (1Z5)</b>		<b>02/2004 → 06/2013</b>	
Control Arm-/Trailing Arm Bush	1.4, 1.4 TSI, 1.6, 1.6 FSI, 1.6 TDI, 1.8 TSI, 1.8 TSI 4x4, 1.9 TDI, 1.9 TDI 4x4, 2.0 FSI, 2.0 FSI 4x4, 2.0 RS, 2.0 TDI, 2.0 TDI 16V, 2.0 TDI 4x4, 2.0 TDI RS	BMN	F8-6463
Engine Mounting	2.0 TDI RS		F8-6528
Engine Mounting	2.0 TDI, 2.0 TDI 16V, 2.0 TDI 4x4		F8-6528
Engine Mounting	1.4, 1.6 FSI		F8-6531
Anti-Friction Bearing	1.2 TSI, 1.4, 1.4 TSI, 1.6, 1.6 FSI, 1.6 LPG, 1.6 MultiFuel, 1.6 TDI, 1.6 TDI 4x4, 1.8 TSI, 1.8 TSI 4x4, 1.9 TDI, 1.9 TDI 4x4, 2.0 FSI, 2.0 FSI 4x4, 2.0 RS, 2.0 TDI, 2.0 TDI 16V, 2.0 TDI 16V 4x4, 2.0 TDI 4x4, 2.0 TDI RS		F8-6569
Top Strut Mounting	All Models		F8-6570
Belt Pulley, crankshaft	1.6 TDI, 1.6 TDI 4x4	ch. 1Z-9A153727, 1Z-A2057742, 1Z-A8021762, 1Z-AC009082, 1Z-AD150036, 1Z-AK151667→; Number of Ribs: 5; Parameter: 6PK	F8-6572
Belt Pulley, crankshaft	2.0 TDI 16V	CFHC, CLCB; Number of Ribs: 5; Parameter: 6PK	F8-6572
Belt Pulley, crankshaft	2.0 TDI, 2.0 TDI 16V 4x4, 2.0 TDI 4x4	Number of Ribs: 5; Parameter: 6PK	F8-6572
Bracket, stabilizer mounting	1.4, 1.6, 1.6 FSI, 1.8 TSI, 1.9 TDI 4x4, 2.0 FSI 4x4, 2.0 RS, 2.0 TDI, 2.0 TDI 16V, 2.0 TDI 4x4, 2.0 TDI RS		F8-6579
Bracket, stabilizer mounting	1.9 TDI	BJB, BKC	F8-6579
Bracket, stabilizer mounting	2.0 FSI	BLR, BLY	F8-6579
Engine Mounting	1.6	ch. 1Z-4-000001→	F8-6988
Engine Mounting	1.8 TSI, 1.8 TSI 4x4, 2.0 FSI, 2.0 FSI 4x4, 2.0 RS		F8-6989
Engine Mounting	1.6 FSI	ch. 1Z-5-016012, 1Z-58030446→;	F8-6991
Rubber Buffer, suspension	1.2 TSI, 1.4, 1.4 TSI, 1.6, 1.6 FSI, 1.6 LPG, 1.6 MultiFuel, 1.6 TDI, 1.6 TDI 4x4, 1.8 TSI, 1.8 TSI 4x4, 1.9 TDI, 1.9 TDI 4x4, 2.0 FSI, 2.0 FSI 4x4, 2.0 TDI, 2.0 TDI 16V, 2.0 TDI 16V 4x4, 2.0 TDI 4x4, 2.0 TDI RS	for OE: 2UA, G02, G07;	F8-7131
Protective Cap/Bellow, shock absorber	1.2 TSI, 1.4, 1.4 TSI, 1.6, 1.6 FSI, 1.6 LPG, 1.6 MultiFuel, 1.6 TDI, 1.6 TDI 4x4, 1.8 TSI, 1.8 TSI 4x4, 1.9 TDI, 1.9 TDI 4x4, 2.0 FSI, 2.0 FSI 4x4, 2.0 RS, 2.0 TDI, 2.0 TDI 16V, 2.0 TDI 16V 4x4, 2.0 TDI 4x4, 2.0 TDI RS		F8-7132
Rubber Buffer, suspension	All Models	for OE: 1JA, 1JB;	F8-7140
Rubber Buffer, suspension	1.6, 1.6 FSI, 1.9 TDI, 2.0 TDI 16V		F8-7600
Top Strut Mounting	1.4, 1.6, 1.6 FSI, 1.8 TSI, 1.9 TDI, 1.9 TDI 4x4, 2.0 FSI, 2.0 FSI 4x4, 2.0 RS, 2.0 TDI, 2.0 TDI 16V, 2.0 TDI 4x4, 2.0 TDI RS	for OE: 3C0513353C; Shape Round	F8-7603
Rubber Buffer, suspension	1.2 TSI, 1.4, 1.4 TSI, 1.6, 1.6 FSI, 1.6 LPG, 1.6 MultiFuel, 1.6 TDI, 1.8 TSI, 1.9 TDI, 2.0 FSI, 2.0 RS, 2.0 TDI, 2.0 TDI 16V, 2.0 TDI RS	for OE: 2UC, G07;	F8-7697

<b>F8-6463</b>	<b>F8-6528</b>	<b>F8-6531</b>	<b>F8-6569</b>	<b>F8-6570</b>	<b>F8-6572</b>	<b>F8-6579</b>
Ref.Nr.: 1K0505541B	Ref.Nr.: 1K0 199 262 AT	Ref.Nr.: 1K0199262T	Ref.Nr.: 6N0412249C	Ref.Nr.: 1K0412331C	Ref.Nr.: 038105243L	Ref.Nr.: 1J0 411 336 C
<b>F8-6988</b>	<b>F8-6989</b>	<b>F8-6991</b>	<b>F8-7131</b>	<b>F8-7132</b>	<b>F8-7140</b>	<b>F8-7600</b>
Ref.Nr.: 1K0199262AL	Ref.Nr.: 1K0199262AM	Ref.Nr.: 1K0199262AK	Ref.Nr.: 1K0412303B	Ref.Nr.: 6N0413175A	Ref.Nr.: 3C0511359	Ref.Nr.: 1K0 511 353 P
<b>F8-7603</b>	<b>F8-7697</b>	<b>F8-7703</b>				
Ref.Nr.: 3C0513353	Ref.Nr.: 1K0412303F	Ref.Nr.: 1K0412303G				

**Article Description****Article Nr.****Fitting Position**

<b>OCTAVIA Combi (1Z5)</b>			<b>02/2004 → 06/2013</b>		
Rubber Buffer, suspension	1.2 TSI, 1.4, 1.4 TSI, 1.6, 1.6 FSI, 1.6 LPG, 1.6 MultiFuel, 1.6 TDI, 1.6 TDI 4x4, 1.8 TSI, 1.8 TSI 4x4, 1.9 TDI, 1.9 TDI 4x4, 2.0 FSI, 2.0 FSI 4x4, 2.0 RS, 2.0 TDI, 2.0 TDI 16V, 2.0 TDI 16V 4x4, 2.0 TDI 4x4, 2.0 TDI RS	for OE: 2UB, G02;	<b>F8-7703</b>		H=90; d=25
Rubber Buffer, suspension	1.2 TSI, 1.4, 1.4 TSI, 1.6 LPG, 1.6 MultiFuel, 1.6 TDI, 1.8 TSI, 2.0 TDI	for OE: 1JC;	<b>F8-7714</b>		H=118
Rubber Buffer, suspension	1.6, 1.6 FSI, 1.9 TDI, 2.0 FSI, 2.0 TDI, 2.0 TDI 16V	05/2006 →; for OE: 1JC;	<b>F8-7714</b>		H=118
Rubber Buffer, suspension	2.0 RS, 2.0 TDI RS	05/2006 →; for OE: 1JC+A8F;	<b>F8-7714</b>		H=118
Rubber Buffer, suspension	1.2 TSI, 1.4, 1.4 TSI, 1.6, 1.6 FSI, 1.6 LPG, 1.6 MultiFuel, 1.6 TDI, 1.8 TSI, 1.9 TDI, 2.0 FSI, 2.0 RS, 2.0 TDI, 2.0 TDI 16V, 2.0 TDI RS	for OE: 2UC, G02;	<b>F8-7809</b>		H=55
Rubber Buffer, suspension	All Models	for OE: 2UB, G06, G07;	<b>F8-7834</b>		H=90
Control Arm-/Trailing Arm Bush	1.4	ch.1Z-8A156314, 1Z-92008800, 1Z-98006050, 1Z-9B150000, 1Z-9C003000, 1Z-9D015004, 1Z-9K150000→; 11/2008 →; TOUR	<b>F8-7856</b>		H=50; d=13.2; D=65
Control Arm-/Trailing Arm Bush	1.6	ch.1Z-8A156314, 1Z-92008800, 1Z-98006050, 1Z-9B150000, 1Z-9C003000, 1Z-9D015004, 1Z-9K150000→; 11/2008 →;  BSE, BSF, CMXA; TOUR; not for  BGU, CCSA	<b>F8-7856</b>		H=50; d=13.2; D=65
Control Arm-/Trailing Arm Bush	1.9 TDI	ch.1Z-8A156314, 1Z-92008800, 1Z-98006050, 1Z-9B150000, 1Z-9C003000, 1Z-9D015004, 1Z-9K150000→; 11/2008 →;  BXE; TOUR; not for  BJB, BKC, BLS	<b>F8-7856</b>		H=50; d=13.2; D=65
Control Arm-/Trailing Arm Bush	2.0 TDI	ch.1Z-8A156314, 1Z-92008800, 1Z-98006050, 1Z-9B150000, 1Z-9C003000, 1Z-9D015004, 1Z-9K150000→; 11/2008 →;  CLCA; TOUR; not for  CFHF	<b>F8-7856</b>		H=50; d=13.2; D=65
Belt Pulley, crankshaft	1.8 TSI, 1.8 TSI 4x4, 2.0 RS	Number of Ribs: 5; Parameter: 6PK	<b>F8-7880</b>		D=143
Rubber Buffer, suspension	1.6, 1.6 FSI, 1.9 TDI, 2.0 FSI, 2.0 TDI, 2.0 TDI 16V	for OE: 1JC; Shape Oval;	<b>F8-7897</b>		H=118
Rubber Buffer, suspension	2.0 RS, 2.0 TDI RS	for OE: 1JC+A8F; Shape Oval;	<b>F8-7897</b>		H=118
Control Arm-/Trailing Arm Bush	All Models		<b>F8-7902</b>		H=60; d=12; D=42
Control Arm-/Trailing Arm Bush	All Models		<b>F8-7907</b>		H=45; d=14; D=38
Control Arm-/Trailing Arm Bush	All Models		<b>F8-7908</b>		H=45; d=12; D=38
Control Arm-/Trailing Arm Bush	All Models		<b>F8-7909</b>		
Stabiliser Mounting	1.6, 1.6 FSI, 1.9 TDI, 1.9 TDI 4x4, 2.0 FSI, 2.0 FSI 4x4, 2.0 RS, 2.0 TDI, 2.0 TDI 16V, 2.0 TDI 4x4		<b>F8-7923</b>		d=20,7
Stabiliser Mounting	1.6, 1.6 FSI, 1.9 TDI, 1.9 TDI 4x4, 2.0 FSI, 2.0 FSI 4x4, 2.0 RS, 2.0 TDI 16V		<b>F8-7930</b>		d=18,5

<b>F8-7703</b>	<b>F8-7714</b>	<b>F8-7809</b>	<b>F8-7834</b>	<b>F8-7856</b>	<b>F8-7880</b>	<b>F8-7897</b>
Ref.Nr.: 1K0412303G	Ref.Nr.: 3C0511359B	Ref.Nr.: 1K0412303E	Ref.Nr.: 1K0412303H	Ref.Nr.: 5C0407183A	Ref.Nr.: 06H105243F	Ref.Nr.: 1K0511353F
<b>F8-7902</b>	<b>F8-7907</b>	<b>F8-7908</b>	<b>F8-7909</b>	<b>F8-7923</b>	<b>F8-7930</b>	<b>F8-7958</b>
Ref.Nr.: 1K0505171C	Ref.Nr.: 1K0505203A	Ref.Nr.: 1K0505279A	Ref.Nr.: 1K0505553 A	Ref.Nr.: 1K0511327AR	Ref.Nr.: 1K0511327AP	Ref.Nr.: 1K0199262AS

Article Description



Article Nr.

Fitting Position



<b>OCTAVIA Combi (1Z5)</b>			<b>02/2004 → 06/2013</b>		
Engine Mounting	1.9 TDI		<b>F8-7958</b>	↻	
Engine Mounting	1.4, 1.4 TSI, 1.6, 1.6 FSI, 1.6 MultiFuel		<b>F8-7960</b>	↻	
Engine Mounting	1.6	ch. 1Z-4-000 001→;  BGU, BSE, BSF	<b>F8-7961</b>	↻	
Engine Mounting	1.6 FSI, 2.0 FSI	ch. 1Z-4-000 001→	<b>F8-7961</b>	↻	
Engine Mounting	1.9 TDI, 2.0 TDI, 2.0 TDI 16V, 2.0 TDI RS		<b>F8-7962</b>	↻	
Engine Mounting	2.0 RS	6-speed	<b>F8-7962</b>	↻	
Engine Mounting	1.2 TSI, 1.4, 1.6 FSI		<b>F8-7965</b>		
Engine Mounting	1.6		<b>F8-7965</b>		
Engine Mounting	1.6	BGU;  6-speed	<b>F8-7966</b>		
Engine Mounting	1.6	BSE, BSF;  6-speed	<b>F8-7966</b>		
Engine Mounting	1.8 TSI, 1.9 TDI, 1.9 TDI 4x4, 2.0 FSI, 2.0 FSI 4x4, 2.0 RS, 2.0 TDI, 2.0 TDI 16V, 2.0 TDI RS		<b>F8-7966</b>		
Engine Mounting	1.8 TSI	BZB	<b>F8-7981</b>	↓	
Engine Mounting	1.9 TDI, 1.9 TDI 4x4, 2.0 FSI 4x4, 2.0 TDI, 2.0 TDI 16V, 2.0 TDI 4x4		<b>F8-7981</b>	↓	
Engine Mounting	2.0 FSI		<b>F8-7981</b>	↓	
Engine Mounting	2.0 RS	BWA	<b>F8-7981</b>	↓	
Engine Mounting	1.2 TSI, 1.4, 1.4 TSI, 1.6, 1.6 FSI, 1.6 MultiFuel, 1.6 TDI, 1.6 TDI 4x4, 1.8 TSI, 1.8 TSI 4x4, 1.9 TDI, 1.9 TDI 4x4, 2.0 RS, 2.0 TDI, 2.0 TDI 16V, 2.0 TDI 16V 4x4, 2.0 TDI 4x4, 2.0 TDI RS		<b>F8-7982</b>	↑	
Engine Mounting	2.0 FSI	BLR, BLY	<b>F8-7982</b>	↑	
Engine Mounting	2.0 FSI 4x4	BLX	<b>F8-7982</b>	↑	
Engine Mounting	1.9 TDI 4x4, 2.0 TDI 16V 4x4, 2.0 TDI 4x4		<b>F8-8152</b>	↻	
Engine Mounting	2.0 TDI	not for equipment variant: TOUR	<b>F8-8152</b>	↻	
Engine Mounting	2.0 TDI 4x4		<b>F8-8152</b>	↻	
Engine Mounting	2.0 TDI, 2.0 TDI 16V, 2.0 TDI RS		<b>F8-8152</b>	↻	
<b>OCTAVIA (5E3)</b>			<b>11/2012 →</b>		
Rubber Buffer, suspension	1.2 TSI, 1.4 TSI, 1.6 TDI, 1.8 TSI, 2.0 TDI	for OE: 2UC;	<b>F8-7809</b>		H=55
Belt Pulley, crankshaft	1.8 TSI	Number of Ribs: 5; Parameter: 6PK	<b>F8-7880</b>		D=143
<b>OCTAVIA Combi (5E5)</b>			<b>11/2012 →</b>		
Alternator Freewheel Clutch	2.0 TDI		<b>F5-1085</b>		
Rubber Buffer, suspension	1.2 TSI, 1.4 TSI, 1.6 TDI, 1.8 TSI, 2.0 TDI	for OE: 2UC;	<b>F8-7809</b>		H=55
Belt Pulley, crankshaft	1.8 TSI	Number of Ribs: 5; Parameter: 6PK	<b>F8-7880</b>		D=143
<b>RAPID (NH3)</b>			<b>07/2012 →</b>		
Alternator Freewheel Clutch	1.2 TSI, 1.4 TSI		<b>F5-1064</b>		

<b>F5-1064</b>	<b>F5-1085</b>	<b>F8-3039</b>	<b>F8-7809</b>	<b>F8-7880</b>	<b>F8-7958</b>	<b>F8-7960</b>
Ref.Nr.: 03C903119D	Ref.Nr.: 045903119A	Ref.Nr.: 357412249A	Ref.Nr.: 1K0412303E	Ref.Nr.: 06H105243F	Ref.Nr.: 1K0199262AS	Ref.Nr.: 1K0199555L
<b>F8-7961</b>	<b>F8-7962</b>	<b>F8-7965</b>	<b>F8-7966</b>	<b>F8-7981</b>	<b>F8-7982</b>	<b>F8-8152</b>
Ref.Nr.: 1K0199555N	Ref.Nr.: 1K0199555Q	Ref.Nr.: 1K0199855BA	Ref.Nr.: 1K0199855BB	Ref.Nr.: 1K0199867Q	Ref.Nr.: 1K0199868Q	Ref.Nr.: 1K0199555T

**Article Description****Article Nr.****Fitting Position**

<b>RAPID (NH3)</b>			<b>07/2012 →</b>		
Anti-Friction Bearing	1.2, 1.2 TSI, 1.4 TSI, 1.6 TDI		<b>F8-3039</b>		H=14; d1=14; D=45
Rubber Buffer, suspension	1.2, 1.2 TSI, 1.4 TSI, 1.6 TDI		<b>F8-5381</b>		H=37; D=76
Rubber Buffer, suspension	1.2, 1.2 TSI, 1.4 TSI, 1.6 TDI	for OE: G45, G46	<b>F8-5996</b>		H=63
Protective Cap/Bellow, shock absorber	1.2, 1.2 TSI, 1.4 TSI, 1.6, 1.6 TDI		<b>F8-6044</b>		H=160
Top Strut Mounting	1.2, 1.2 TSI, 1.4 TSI, 1.6 TDI	for OE: 1J0412319C	<b>F8-7133</b>		
Engine Mounting	1.2 TSI, 1.6		<b>F8-8164</b>		
<b>RAPID Spaceback (NH1)</b>			<b>07/2012 →</b>		
Alternator Freewheel Clutch	1.6 TDI		<b>F5-1004</b>		
Alternator Freewheel Clutch	1.2 TSI, 1.4 TSI		<b>F5-1064</b>		
Engine Mounting	1.2 TSI, 1.6		<b>F8-8164</b>		
<b>ROOMSTER (5J)</b>			<b>03/2006 → 05/2015</b>		
Dust Cover Kit, shock absorber	1.2, 1.4, 1.4 TDI, 1.6, 1.9 TDI		<b>AK-735004</b>		
Dust Cover Kit, shock absorber	1.2, 1.4, 1.4 TDI, 1.6, 1.9 TDI		<b>AK-735267</b>		
Alternator Freewheel Clutch	1.2 TDI, 1.4 TDI, 1.6 TDI, 1.9 TDI		<b>F5-1004</b>		
Alternator Freewheel Clutch	1.2 TSI		<b>F5-1064</b>		
Anti-Friction Bearing	1.2 TDI, 1.2 TSI, 1.6 TDI	for OE: G38, G39;	<b>F8-3039</b>		H=14; d1=14; D=45
Anti-Friction Bearing	1.2 TDI, 1.2 TSI, 1.6 TDI	for OE: G40, G41;	<b>F8-3039</b>		H=14; d1=14; D=45
Anti-Friction Bearing	1.2, 1.4, 1.4 TDI, 1.6, 1.9 TDI	01/2009 →; for OE: G38, G39;	<b>F8-3039</b>		H=14; d1=14; D=45
Anti-Friction Bearing	1.2, 1.4, 1.4 TDI, 1.6, 1.9 TDI	ch.5J-95032165, 5J-9B601132 →; 01/2009 →; for OE: G40, G41;	<b>F8-3039</b>		H=14; d1=14; D=45
Top Strut Mounting	1.2 TDI, 1.2 TSI, 1.6 TDI	for OE: G38, G39;	<b>F8-4067</b>		H=53; d=26; D=82
Top Strut Mounting	1.2 TDI, 1.2 TSI, 1.6 TDI	for OE: G40, G41;	<b>F8-4067</b>		H=53; d=26; D=82
Top Strut Mounting	1.2, 1.4, 1.4 TDI, 1.6, 1.9 TDI	01/2009 →; for OE: G38, G39;	<b>F8-4067</b>		H=53; d=26; D=82
Top Strut Mounting	1.2, 1.4, 1.4 TDI, 1.6, 1.9 TDI	ch.5J-95032165, 5J-9B601132 →; 01/2009 →; for OE: G40, G41;	<b>F8-4067</b>		H=53; d=26; D=82
Rubber Buffer, suspension	All Models		<b>F8-5381</b>		H=37; D=76
Engine Mounting	1.4, 1.6		<b>F8-5534</b>		
Top Strut Mounting	1.2, 1.4, 1.4 TDI, 1.6, 1.9 TDI	ch. → 5J-95032164, 5J-9B601131; for OE: G40, G41;	<b>F8-5537</b>		
Top Strut Mounting	1.2, 1.9 TDI	for OE: G40, G41;	<b>F8-5537</b>		
Protective Cap/Bellow, shock absorber	1.2 TDI, 1.2 TSI, 1.6 TDI	for OE: G38, G39;	<b>F8-5683</b>		H=210
Protective Cap/Bellow, shock absorber	1.2 TDI, 1.2 TSI, 1.6 TDI	for OE: G40, G41;	<b>F8-5683</b>		H=210
Protective Cap/Bellow, shock absorber	1.2, 1.4, 1.4 TDI, 1.6, 1.9 TDI	01/2009 →; for OE: G38, G39;	<b>F8-5683</b>		H=210

<b>AK-735004</b>	<b>AK-735267</b>	<b>F5-1004</b>	<b>F5-1064</b>	<b>F8-3039</b>	<b>F8-4067</b>	<b>F8-5381</b>
Ref.Nr.:	Ref.Nr.: 1J0512131	Ref.Nr.: 038903119T	Ref.Nr.: 03C903119D	Ref.Nr.: 357412249A	Ref.Nr.: 1J0412331B	Ref.Nr.: 1J0512149B
<b>F8-5534</b>	<b>F8-5537</b>	<b>F8-5683</b>	<b>F8-5996</b>	<b>F8-6044</b>	<b>F8-7133</b>	
Ref.Nr.: 6Q0199851AB	Ref.Nr.: 6N0412331E	Ref.Nr.: 357413175A	Ref.Nr.: 1H0412303B	Ref.Nr.: 3C0513425	Ref.Nr.: 1J0412319C	Ref.Nr.: 6Q0199555AS

Article Description



Article Nr.

Fitting Position



ROOMSTER (5J)			03/2006 → 05/2015		
Protective Cap/Bellow, shock absorber	1.2, 1.4, 1.4 TDI, 1.6, 1.9 TDI	ch.5J-95032165, 5J-9B601132→; 01/2009 →; for OE: G40, G41; <b>ST</b>	<b>F8-5683</b>		H=210
Rubber Buffer, suspension	1.2 TDI, 1.2 TSI, 1.6 TDI	for OE: G38, G39; <b>QI</b>	<b>F8-5993</b>		H=83
Rubber Buffer, suspension	1.2, 1.4, 1.4 TDI, 1.6, 1.9 TDI	01/2009 →; for OE: G38, G39; <b>QI</b>	<b>F8-5993</b>		H=83
Rubber Buffer, suspension	1.2 TDI, 1.2 TSI, 1.6 TDI	for OE: G40, G41; <b>ST</b>	<b>F8-5996</b>		H=63
Rubber Buffer, suspension	1.2, 1.4, 1.4 TDI, 1.6, 1.9 TDI	ch.5J-95032165, 5J-9B601132→; for OE: G40, G41; <b>ST</b>	<b>F8-5996</b>		H=63
Top Strut Mounting	1.2, 1.4, 1.4 TDI, 1.6, 1.9 TDI		<b>F8-6040</b>		
Protective Cap/Bellow, shock absorber	All Models		<b>F8-6044</b>		H=160
Mounting, axle beam	1.2, 1.4, 1.4 TDI, 1.6, 1.9 TDI		<b>F8-6076</b>		d=12; L=90; D=69
Repair Set, axle beam	1.2, 1.4, 1.4 TDI, 1.6		<b>F8-6077</b>		H=90; D=69
Repair Set, axle beam	1.9 TDI	BSW	<b>F8-6077</b>		H=90; D=69
Top Strut Mounting	1.2 TDI, 1.2 TSI, 1.6 TDI	for OE: G38, G39; <b>QI</b>	<b>F8-6280</b>		H=53; d=26; D=82
Top Strut Mounting	1.2 TDI, 1.2 TSI, 1.6 TDI	for OE: G40, G41; <b>QI</b>	<b>F8-6280</b>		H=53; d=26; D=82
Top Strut Mounting	1.2, 1.4, 1.4 TDI, 1.6, 1.9 TDI	01/2009 →; for OE: G38, G39; <b>QI</b>	<b>F8-6280</b>		H=53; d=26; D=82
Top Strut Mounting	1.2, 1.4, 1.4 TDI, 1.6, 1.9 TDI	ch.5J-95032165, 5J-9B601132→; 01/2009 →; for OE: G40, G41; <b>QI</b>	<b>F8-6280</b>		H=53; d=26; D=82
Top Strut Mounting	1.2, 1.4, 1.4 TDI, 1.6, 1.9 TDI	ch.→5J-95032164, 5J-9B601131; for OE: G40, G41; <b>QI</b>	<b>F8-6281</b>		
Top Strut Mounting	1.2, 1.9 TDI	for OE: G40, G41; <b>QI</b>	<b>F8-6281</b>		
Stabiliser Mounting	1.2, 1.4, 1.4 TDI, 1.6, 1.9 TDI	ch.6Y-3-651671→	<b>F8-6460</b>		d=18
Anti-Friction Bearing	1.2, 1.4, 1.4 TDI, 1.6, 1.9 TDI	ch.→5J-95032164, 5J-9B601131; for OE: G40, G41; <b>ST</b>	<b>F8-6569</b>		
Anti-Friction Bearing	1.2, 1.4, 1.4 TDI, 1.6, 1.9 TDI	for OE: G38, G39; <b>QI</b>	<b>F8-6569</b>		
Anti-Friction Bearing	1.2, 1.9 TDI	ch.→5J-95032164; for OE: G40, G41; <b>ST</b>	<b>F8-6569</b>		
Belt Pulley, crankshaft	1.2 TDI, 1.6 TDI	Number of Ribs: 5; Parameter: 6PK	<b>F8-6572</b>		
Control Arm-/Trailing Arm Bush	1.2, 1.4, 1.4 TDI, 1.6, 1.9 TDI		<b>F8-6736</b>		
Protective Cap/Bellow, shock absorber	1.2, 1.4, 1.4 TDI, 1.6, 1.9 TDI	ch.→5J-95032164, 5J-9B601131; for OE: G40, G41; <b>ST</b>	<b>F8-7132</b>		H=190
Protective Cap/Bellow, shock absorber	1.2, 1.4, 1.4 TDI, 1.6, 1.9 TDI	ch.→5J-95032164; for OE: G38, G39; <b>QI</b>	<b>F8-7132</b>		H=190
Protective Cap/Bellow, shock absorber	1.2, 1.9 TDI	for OE: G40, G41; <b>ST</b>	<b>F8-7132</b>		H=190
Top Strut Mounting	All Models	for OE: 1J0412319C	<b>F8-7133</b>		
Rubber Buffer, suspension	1.2, 1.4, 1.4 TDI, 1.6, 1.9 TDI	for OE: G38, G39; <b>QI</b>	<b>F8-7675</b>		H=84
Rubber Buffer, suspension	1.2, 1.4, 1.4 TDI, 1.6, 1.9 TDI	ch.→5J-95032164, 5J-9B601131; for OE: G40, G41; <b>ST</b>	<b>F8-7830</b>		

<b>F8-5683</b>	<b>F8-5993</b>	<b>F8-5996</b>	<b>F8-6040</b>	<b>F8-6044</b>	<b>F8-6076</b>	<b>F8-6077</b>
Ref.Nr.: 357413175A	Ref.Nr.: 357412303F	Ref.Nr.: 1H0412303B	Ref.Nr.: 1J0513353D	Ref.Nr.: 3C0513425	Ref.Nr.: 1J0501541D	Ref.Nr.: 1J0501541DS
<b>F8-6280</b>	<b>F8-6281</b>	<b>F8-6460</b>	<b>F8-6569</b>	<b>F8-6572</b>	<b>F8-6736</b>	<b>F8-7132</b>
Ref.Nr.: 6R0412249	Ref.Nr.: 8Z0412331	Ref.Nr.: 6Q0411314R	Ref.Nr.: 6N0412249C	Ref.Nr.: 038105243L	Ref.Nr.: 1K0407183A	Ref.Nr.: 6N0413175A
<b>F8-7133</b>	<b>F8-7675</b>	<b>F8-7830</b>				
Ref.Nr.: 1J0412319C	Ref.Nr.: 6Q0412301	Ref.Nr.: 6N0412303A				

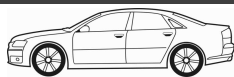
**Article Description****Article Nr.****Fitting Position**

<b>ROOMSTER (5J)</b>			<b>03/2006 → 05/2015</b>		
Rubber Buffer, suspension	1.2, 1.9 TDI	for OE: G40, G41; <b>ST</b>	<b>F8-7830</b>		
Control Arm-/Trailing Arm Bush	1.2, 1.4, 1.4 TDI, 1.6, 1.9 TDI	ch.→5J-85069020, 5J-8B600704	<b>F8-7873</b>		
Engine Mounting	1.4, 1.6		<b>F8-7949</b>		
Engine Mounting	1.4 TDI		<b>F8-7950</b>		
Engine Mounting	1.2, 1.2 TSI, 1.4, 1.6		<b>F8-7951</b>		
Engine Mounting	1.2		<b>F8-7955</b>		
Engine Mounting	1.2	5-speed	<b>F8-7955</b>		
Engine Mounting	1.9 TDI		<b>F8-7956</b>		
Control Arm-/Trailing Arm Bush	All Models		<b>F8-7978</b>		
Belt Pulley, crankshaft	1.4 TDI	Number of Ribs: 5; Parameter: 6PK	<b>F8-8038</b>		
Engine Mounting	1.4 TDI, 1.6		<b>F8-8164</b>		
Engine Mounting	1.9 TDI	5-speed	<b>F8-8173</b>		
<b>ROOMSTER Praktik (5J)</b>			<b>03/2007 → 05/2015</b>		
Dust Cover Kit, shock absorber	All Models	<b>ST</b>	<b>AK-735410</b>		
Alternator Freewheel Clutch	1.2 TDI, 1.4 TDI, 1.6 TDI		<b>F5-1004</b>		
Alternator Freewheel Clutch	1.2 TSI		<b>F5-1064</b>		
Anti-Friction Bearing	1.2 TDI, 1.2 TSI, 1.6 TDI	for OE: G38, G39;	<b>F8-3039</b>		
Anti-Friction Bearing	1.2 TDI, 1.2 TSI, 1.6 TDI	for OE: G40, G41; <b>ST</b>	<b>F8-3039</b>		
Anti-Friction Bearing	1.2, 1.4, 1.4 TDI	01/2009 →; for OE: G38, G39;	<b>F8-3039</b>		
Anti-Friction Bearing	1.2, 1.4, 1.4 TDI	ch.5J-95032165, 5J-9B601132 →; 01/2009 →; for OE: G40, G41; <b>ST</b>	<b>F8-3039</b>		
Top Strut Mounting	1.2 TDI, 1.2 TSI, 1.6 TDI	for OE: G38, G39; ;	<b>F8-4067</b>		
Top Strut Mounting	1.2 TDI, 1.2 TSI, 1.6 TDI	for OE: G40, G41; ; <b>ST</b>	<b>F8-4067</b>		
Top Strut Mounting	1.2, 1.4, 1.4 TDI	01/2009 →; for OE: G38, G39; ;	<b>F8-4067</b>		
Top Strut Mounting	1.2, 1.4, 1.4 TDI	ch.5J-95032165, 5J-9B601132 →; 01/2009 →; for OE: G40, G41; ; <b>ST</b>	<b>F8-4067</b>		
Rubber Buffer, suspension	All Models		<b>F8-5381</b>		
Engine Mounting	1.4	5-speed	<b>F8-5534</b>		
Top Strut Mounting	1.2, 1.4, 1.4 TDI	ch.→5J-95032164, 5J-9B601131; for OE: G40, G41; ; <b>ST</b>	<b>F8-5537</b>		
Protective Cap/Bellow, shock absorber	1.2 TDI, 1.2 TSI, 1.6 TDI	for OE: G38, G39;	<b>F8-5683</b>		
Protective Cap/Bellow, shock absorber	1.2 TDI, 1.2 TSI, 1.6 TDI	for OE: G40, G41; <b>ST</b>	<b>F8-5683</b>		
Protective Cap/Bellow, shock absorber	1.2, 1.4, 1.4 TDI	01/2009 →; for OE: G38, G39;	<b>F8-5683</b>		

<b>AK-735410</b>	<b>F5-1004</b>	<b>F5-1064</b>	<b>F8-3039</b>	<b>F8-4067</b>	<b>F8-5381</b>	<b>F8-5534</b>
Ref.Nr.: 1J0412303	Ref.Nr.: 038903119T	Ref.Nr.: 03C903119D	Ref.Nr.: 357412249A	Ref.Nr.: 1J0412331B	Ref.Nr.: 1J0512149B	Ref.Nr.: 6Q0199851AB
<b>F8-5537</b>	<b>F8-5683</b>	<b>F8-7830</b>	<b>F8-7873</b>	<b>F8-7949</b>	<b>F8-7950</b>	<b>F8-7951</b>
Ref.Nr.: 6N0412331E	Ref.Nr.: 357413175A	Ref.Nr.: 6N0412303A	Ref.Nr.: 6Q0407182A	Ref.Nr.: 6Q0199851AK	Ref.Nr.: 6Q0199851AQ	Ref.Nr.: 6Q0199555AR
<b>F8-7955</b>	<b>F8-7956</b>	<b>F8-7978</b>	<b>F8-8038</b>	<b>F8-8164</b>	<b>F8-8173</b>	
Ref.Nr.: 6Q0199851AJ	Ref.Nr.: 6Q0199851AP	Ref.Nr.: 357407182F	Ref.Nr.: 045105243C	Ref.Nr.: 6Q0199555AS	Ref.Nr.: 6Q0199555AT	

Article Description



Article Nr.

Fitting Position



## ROOMSTER Praktik (5J)

03/2007 → 05/2015

Protective Cap/Bellow, shock absorber	1.2, 1.4, 1.4 TDI	ch.5J-95032165, 5J-9B601132→; 01/2009 →; for OE: G40, G41; <b>ST</b>	<b>F8-5683</b>		H=210
Rubber Buffer, suspension	1.2 TDI, 1.2 TSI, 1.6 TDI	for OE: G38, G39; <b>QI</b>	<b>F8-5993</b>		H=83
Rubber Buffer, suspension	1.2, 1.4, 1.4 TDI	01/2009 →; for OE: G38, G39; <b>QI</b>	<b>F8-5993</b>		H=83
Rubber Buffer, suspension	1.2 TDI, 1.2 TSI, 1.6 TDI	for OE: G40, G41; <b>ST</b>	<b>F8-5996</b>		H=63
Rubber Buffer, suspension	1.2, 1.4, 1.4 TDI	ch.5J-95032165, 5J-9B601132→; for OE: G40, G41; <b>ST</b>	<b>F8-5996</b>		H=63
Top Strut Mounting	1.2, 1.4, 1.4 TDI		<b>F8-6040</b>		
Protective Cap/Bellow, shock absorber	All Models		<b>F8-6044</b>		H=160
Top Strut Mounting	1.2 TDI, 1.2 TSI, 1.6 TDI	for OE: G38, G39; <b>QI</b>	<b>F8-6280</b>		H=53; d=26; D=82
Top Strut Mounting	1.2 TDI, 1.2 TSI, 1.6 TDI	for OE: G40, G41; <b>QI</b> ; <b>ST</b>	<b>F8-6280</b>		H=53; d=26; D=82
Top Strut Mounting	1.2, 1.4, 1.4 TDI	01/2009 →; for OE: G38, G39; <b>QI</b>	<b>F8-6280</b>		H=53; d=26; D=82
Top Strut Mounting	1.2, 1.4, 1.4 TDI	ch.5J-95032165, 5J-9B601132→; 01/2009 →; for OE: G40, G41; <b>QI</b> ; <b>ST</b>	<b>F8-6280</b>		H=53; d=26; D=82
Top Strut Mounting	1.2, 1.4, 1.4 TDI	ch.→5J-95032164, 5J-9B601131; for OE: G40, G41; <b>QI</b> ; <b>ST</b>	<b>F8-6281</b>		
Stabiliser Mounting	1.2, 1.4, 1.4 TDI	ch.6Y-3-651671→	<b>F8-6460</b>		d=18
Stabiliser Mounting	1.2	Stabi. Diam. [mm]= 18	<b>F8-6462</b>		d=16
Anti-Friction Bearing	1.2, 1.4, 1.4 TDI	ch.→5J-95032164, 5J-9B601131; for OE: G40, G41; <b>ST</b>	<b>F8-6569</b>		
Anti-Friction Bearing	1.2, 1.4, 1.4 TDI	for OE: G38, G39; <b>QI</b>	<b>F8-6569</b>		
Belt Pulley, crankshaft	1.2 TDI, 1.6 TDI	Number of Ribs: 5; Parameter: 6PK	<b>F8-6572</b>		
Protective Cap/Bellow, shock absorber	1.2, 1.4, 1.4 TDI	ch.→5J-95032164, 5J-9B601131; for OE: G40, G41; <b>ST</b>	<b>F8-7132</b>		H=190
Protective Cap/Bellow, shock absorber	1.2, 1.4, 1.4 TDI	ch.→5J-95032164; for OE: G38, G39; <b>QI</b>	<b>F8-7132</b>		H=190
Top Strut Mounting	All Models	for OE: 1J0412319C	<b>F8-7133</b>		
Rubber Buffer, suspension	1.2, 1.4, 1.4 TDI	for OE: G38, G39; <b>QI</b>	<b>F8-7675</b>		H=84
Rubber Buffer, suspension	1.2, 1.4, 1.4 TDI	ch.→5J-95032164, 5J-9B601131; for OE: G40, G41; <b>ST</b>	<b>F8-7830</b>		
Engine Mounting	1.4		<b>F8-7949</b>		
Engine Mounting	1.4 TDI		<b>F8-7950</b>		
Engine Mounting	1.2, 1.2 TSI, 1.4		<b>F8-7951</b>		
Control Arm-/Trailing Arm Bush	All Models		<b>F8-7978</b>		
Engine Mounting	1.4 TDI		<b>F8-8164</b>		

## SUPERB (3U4)

12/2001 → 03/2008

Dust Cover Kit, shock absorber	1.8 T, 1.9 TDI, 2.0, 2.5 TDI, 2.8 V6		<b>AK-735127</b>		
--------------------------------	--------------------------------------	--	------------------	--	--

<b>AK-735127</b>	<b>F5-1002</b>	<b>F8-5683</b>	<b>F8-5993</b>	<b>F8-5996</b>	<b>F8-6040</b>	<b>F8-6044</b>
Ref.Nr.:	Ref.Nr.: 038903119P	Ref.Nr.: 357413175A	Ref.Nr.: 357412303F	Ref.Nr.: 1H0412303B	Ref.Nr.: 1J0513353D	Ref.Nr.: 3C0513425
<b>F8-6280</b>	<b>F8-6281</b>	<b>F8-6460</b>	<b>F8-6462</b>	<b>F8-6569</b>	<b>F8-6572</b>	<b>F8-7132</b>
Ref.Nr.: 6R0412249	Ref.Nr.: 8Z0412331	Ref.Nr.: 6Q0411314R	Ref.Nr.: 6Q0411314L	Ref.Nr.: 6N0412249C	Ref.Nr.: 038105243L	Ref.Nr.: 6N0413175A
<b>F8-7133</b>	<b>F8-7675</b>	<b>F8-7830</b>	<b>F8-7949</b>	<b>F8-7950</b>	<b>F8-7951</b>	<b>F8-7978</b>
Ref.Nr.: 1J0412319C	Ref.Nr.: 6Q0412301	Ref.Nr.: 6N0412303A	Ref.Nr.: 6Q0199851AK	Ref.Nr.: 6Q0199851AQ	Ref.Nr.: 6Q0199555AR	Ref.Nr.: 357407182F



**Article Description****Article Nr.****Fitting Position**

<b>SUPERB (3U4)</b>				<b>12/2001 → 03/2008</b>	
Alternator Freewheel Clutch	2.0			<b>F5-1002</b>	
Alternator Freewheel Clutch	1.8 T, 1.9 TDI, 2.0, 2.0 TDI			<b>F5-1006</b>	
Control Arm-/Trailing Arm Bush	1.8 T, 1.9 TDI, 2.0, 2.0 TDI, 2.5 TDI, 2.8 V6			<b>F8-4045</b>	H1=31; H2=60; d=12; D=50
Engine Mounting	1.8 T, 2.0			<b>F8-5538</b>	
Control Arm-/Trailing Arm Bush	1.8 T, 1.9 TDI, 2.0, 2.5 TDI, 2.8 V6			<b>F8-5542</b>	H=40; d=10; D=46
Engine Mounting	2.8 V6			<b>F8-5567</b>	
Rubber Buffer, suspension	1.8 T, 1.9 TDI, 2.0, 2.5 TDI, 2.8 V6			<b>F8-5994</b>	H=85
Rubber Buffer, suspension	1.8 T, 1.9 TDI, 2.0, 2.5 TDI, 2.8 V6			<b>F8-6001</b>	H=134
Rubber Buffer, suspension	1.8 T, 1.9 TDI, 2.0, 2.0 TDI, 2.5 TDI, 2.8 V6	<b>SP</b>		<b>F8-6003</b>	H=103.5
Spring Cap	1.8 T, 1.9 TDI, 2.0, 2.0 TDI, 2.5 TDI, 2.8 V6			<b>F8-6283</b>	
Top Strut Mounting	1.8 T, 1.9 TDI, 2.0, 2.0 TDI, 2.5 TDI, 2.8 V6			<b>F8-6351</b>	
Belt Pulley, crankshaft	1.9 TDI	Number of Ribs: 7		<b>F8-6391</b>	
Mounting, axle beam	1.8 T, 1.9 TDI, 2.0, 2.5 TDI, 2.8 V6	Paired article nr: F8-6431		<b>F8-6430</b>	
Mounting, axle beam	1.9 TDI	AWX; Paired article nr: F8-6431		<b>F8-6430</b>	
Mounting, axle beam	1.8 T, 1.9 TDI, 2.0, 2.5 TDI, 2.8 V6	Paired article nr: F8-6430		<b>F8-6431</b>	
Mounting, axle beam	1.9 TDI	AWX; Paired article nr: F8-6430		<b>F8-6431</b>	
Engine Mounting	2.5 TDI			<b>F8-6530</b>	
Belt Pulley, crankshaft	1.9 TDI, 2.0 TDI			<b>F8-6573</b>	
Rubber Buffer, engine mounting	2.5 TDI	ch.3U-8-000001→		<b>F8-6758</b>	
Engine Mounting	2.5 TDI			<b>F8-6949</b>	
Mounting, manual transmission	2.5 TDI	Transmission Nr: GHA, HEN, HSL;  6-speed		<b>F8-7048</b>	
Top Strut Mounting	1.8 T, 1.9 TDI, 2.0, 2.0 TDI, 2.5 TDI, 2.8 V6			<b>F8-7471</b>	
Protective Cap/Bellow, shock absorber	1.8 T, 1.9 TDI, 2.0, 2.0 TDI, 2.5 TDI, 2.8 V6			<b>F8-7687</b>	H=80
Protective Cap/Bellow, shock absorber	1.8 T, 1.9 TDI, 2.0, 2.0 TDI, 2.5 TDI, 2.8 V6	for OE: 1BB;		<b>F8-7802</b>	H=156
Mounting, manual transmission	2.5 TDI	5-speed		<b>F8-7971</b>	
Control Arm-/Trailing Arm Bush	1.8 T, 1.9 TDI, 2.0, 2.5 TDI, 2.8 V6			<b>G9-615</b>	H1=66; H2=80; d=12; D=65
Bellow, steering	1.8 T, 1.9 TDI, 2.0, 2.0 TDI, 2.5 TDI, 2.8 V6	; with clamps;		<b>LM-10021S</b>	d1=20; d2=63; L [mm]=254
Bellow, steering	1.8 T, 1.9 TDI, 2.0, 2.0 TDI, 2.5 TDI, 2.8 V6	; with clamps;		<b>LM-10021S</b>	d1=20; d2=63; L [mm]=254
<b>SUPERB (3T4)</b>				<b>03/2008 → 05/2015</b>	
Alternator Freewheel Clutch	1.6 TDI, 2.0 TDI, 2.0 TDI 16V, 2.0 TDI 16V 4x4, 2.0 TDI 4x4			<b>F5-1004</b>	

<b>F5-1002</b>	<b>F5-1004</b>	<b>F5-1006</b>	<b>F5-1044</b>	<b>F8-4045</b>	<b>F8-5538</b>	<b>F8-5542</b>
Ref.Nr.: 038903119P	Ref.Nr.: 038903119T	Ref.Nr.: 038903119M	Ref.Nr.: 06B903119B	Ref.Nr.: 4D0407182E	Ref.Nr.: 8D0199382L	Ref.Nr.: 4B0407515
<b>F8-5567</b>	<b>F8-5994</b>	<b>F8-6001</b>	<b>F8-6003</b>	<b>F8-6283</b>	<b>F8-6351</b>	<b>F8-6391</b>
Ref.Nr.: 8D0199379K	Ref.Nr.: 8D0412131F	Ref.Nr.: 3B0512131H	Ref.Nr.: 4B0512131B	Ref.Nr.: 8D0412065E	Ref.Nr.: 3B0513353	Ref.Nr.: 038105243F
<b>F8-6430</b>	<b>F8-6431</b>	<b>F8-6530</b>	<b>F8-6573</b>	<b>F8-6758</b>	<b>F8-6949</b>	<b>F8-7048</b>
Ref.Nr.: 4B0501522E	Ref.Nr.: 4B0501521D	Ref.Nr.: 4B0 199 379 E	Ref.Nr.: 03G 105 243B	Ref.Nr.: 8D0199339E	Ref.Nr.: 3B7199379A	Ref.Nr.: 3B0399151

Article Description



Article Nr.

Fitting Position



<b>SUPERB (3T4)</b>		<b>03/2008 → 05/2015</b>	
Alternator Freewheel Clutch	1.8 TSI, 1.8 TSI 4x4, 2.0 TSI		<b>F5-1044</b>
Alternator Freewheel Clutch	1.4 TSI, 1.6 TDI		<b>F5-1064</b>
Alternator Freewheel Clutch	1.6 TDI, 1.9 TDI, 2.0 TDI, 2.0 TDI 16V, 2.0 TDI 16V 4x4, 2.0 TDI 4x4, 3.6 FSI 4x4, 3.6 V6 4x4		<b>F5-1085</b>
Control Arm-/Trailing Arm Bush	1.4 TSI, 1.6 TDI, 1.8 TSI, 1.8 TSI 4x4, 1.9 TDI, 2.0 TDI, 2.0 TDI 16V, 2.0 TDI 4x4, 2.0 TSI, 3.6 FSI 4x4, 3.6 V6 4x4		<b>F8-5633</b>
Protective Cap/Bellow, shock absorber	All Models	for OE: 1JA, 1JB, 1JC, 1JD; <b>SP</b> , <b>ST</b>	<b>F8-6044</b>
Top Strut Mounting	1.4 TSI, 1.8 TSI, 1.8 TSI 4x4, 1.9 TDI, 2.0 TDI, 2.0 TDI 4x4, 3.6 V6 4x4		<b>F8-6284</b>
Control Arm-/Trailing Arm Bush	1.4 TSI, 1.8 TSI, 1.8 TSI 4x4, 1.9 TDI, 2.0 TDI, 2.0 TDI 16V, 2.0 TDI 4x4, 3.6 V6 4x4	Aluminium	<b>F8-6424</b>
Control Arm-/Trailing Arm Bush	1.4 TSI, 1.8 TSI, 1.8 TSI 4x4, 1.9 TDI, 2.0 TDI, 2.0 TDI 16V, 2.0 TDI 4x4, 3.6 V6 4x4	Aluminium	<b>F8-6425</b>
Control Arm-/Trailing Arm Bush	1.4 TSI, 1.8 TSI, 1.8 TSI 4x4, 1.9 TDI, 2.0 TDI, 2.0 TDI 16V, 2.0 TDI 4x4, 3.6 V6 4x4		<b>F8-6463</b>
Engine Mounting	2.0 TDI		<b>F8-6528</b>
Engine Mounting	2.0 TDI 16V	BKD	<b>F8-6528</b>
Anti-Friction Bearing	1.4 TSI, 1.6 TDI, 1.8 TSI, 1.8 TSI 4x4, 1.9 TDI, 2.0 TDI, 2.0 TDI 16V, 2.0 TDI 16V 4x4, 2.0 TDI 4x4, 2.0 TSI, 3.6 FSI 4x4, 3.6 V6 4x4	for OE: 2UD, G55, G56; <b>SP</b>	<b>F8-6569</b>
Anti-Friction Bearing	1.4 TSI, 1.6 TDI, 1.8 TSI, 1.8 TSI 4x4, 1.9 TDI, 2.0 TDI, 2.0 TDI 16V, 2.0 TDI 16V 4x4, 2.0 TDI 4x4, 2.0 TSI, 3.6 FSI 4x4, 3.6 V6 4x4	for OE: G53, G54; <b>SP</b>	<b>F8-6569</b>
Anti-Friction Bearing	1.4 TSI, 1.6 TDI, 1.8 TSI, 1.8 TSI 4x4, 1.9 TDI, 2.0 TDI, 2.0 TDI 16V, 2.0 TDI 16V 4x4, 2.0 TDI 4x4, 2.0 TSI, 3.6 FSI 4x4, 3.6 V6 4x4	<b>ST</b>	<b>F8-6569</b>
Top Strut Mounting	1.4 TSI, 1.6 TDI, 1.8 TSI, 1.8 TSI 4x4, 1.9 TDI, 2.0 TDI, 2.0 TDI 16V, 2.0 TDI 16V 4x4, 2.0 TDI 4x4, 2.0 TSI, 3.6 V6 4x4		<b>F8-6570</b>
Belt Pulley, crankshaft	1.6 TDI, 2.0 TDI 16V 4x4	Number of Ribs: 5; Parameter: 6PK	<b>F8-6572</b>
Engine Mounting	1.8 TSI, 1.8 TSI 4x4, 2.0 TSI		<b>F8-6989</b>
Rubber Buffer, suspension	1.4 TSI, 1.6 TDI, 1.8 TSI, 1.9 TDI, 2.0 TDI, 2.0 TDI 16V, 2.0 TSI	for OE: G02, G07, G15, G50, G51	<b>F8-7131</b>
Rubber Buffer, suspension	1.8 TSI 4x4, 2.0 TDI 16V 4x4, 2.0 TDI 4x4, 3.6 V6 4x4	for OE: 2UD;	<b>F8-7131</b>
Protective Cap/Bellow, shock absorber	1.4 TSI, 1.6 TDI, 1.8 TSI, 1.8 TSI 4x4, 1.9 TDI, 2.0 TDI, 2.0 TDI 16V, 2.0 TDI 16V 4x4, 2.0 TDI 4x4, 2.0 TSI, 3.6 V6 4x4		<b>F8-7132</b>
Rubber Buffer, suspension	All Models	for OE: 1JA, 1JB, 1JD; <b>ST</b>	<b>F8-7140</b>
Top Strut Mounting	All Models		<b>F8-7603</b>
Rubber Buffer, suspension	1.4 TSI, 1.6 TDI, 1.8 TSI, 1.8 TSI 4x4, 1.9 TDI, 2.0 TDI, 2.0 TDI 16V, 2.0 TDI 16V 4x4, 2.0 TDI 4x4, 2.0 TSI, 3.6 V6 4x4	for OE: G53, G54; <b>SP</b>	<b>F8-7697</b>

<b>F5-1044</b>	<b>F5-1064</b>	<b>F5-1085</b>	<b>F8-5633</b>	<b>F8-6044</b>	<b>F8-6284</b>	<b>F8-6424</b>
Ref.Nr.: 06B903119B	Ref.Nr.: 03C903119D	Ref.Nr.: 045903119A	Ref.Nr.: 1K0407182A	Ref.Nr.: 3C0513425	Ref.Nr.: 6N0412249C	Ref.Nr.: 1K0199232G
<b>F8-6425</b>	<b>F8-6463</b>	<b>F8-6528</b>	<b>F8-6569</b>	<b>F8-6570</b>	<b>F8-6572</b>	<b>F8-6989</b>
Ref.Nr.: 1K0199231J	Ref.Nr.: 1K0505541B	Ref.Nr.: 1K0 199 262 AT	Ref.Nr.: 6N0412249C	Ref.Nr.: 1K0412331C	Ref.Nr.: 038105243L	Ref.Nr.: 1K0199262AM
<b>F8-7131</b>	<b>F8-7132</b>	<b>F8-7140</b>	<b>F8-7603</b>	<b>F8-7697</b>	<b>F8-7714</b>	
Ref.Nr.: 1K0412303B	Ref.Nr.: 6N0413175A	Ref.Nr.: 3C0511359	Ref.Nr.: 3C0513353	Ref.Nr.: 1K0412303F	Ref.Nr.: 3C0511359B	

**Article Description****Article Nr.****Fitting Position**

<b>SUPERB (3T4)</b>			<b>03/2008 → 05/2015</b>		
Rubber Buffer, suspension	All Models	for OE: 1JC; <b>SP</b>	<b>F8-7714</b>		H=118
Rubber Buffer, suspension	All Models	for OE: G55, G56; <b>Δ</b>	<b>F8-7834</b>		H=90
Control Arm-/Trailing Arm Bush	1.4 TSI, 1.8 TSI, 1.8 TSI 4x4, 1.9 TDI, 2.0 TDI, 2.0 TDI 16V, 2.0 TDI 4x4, 2.0 TSI, 3.6 FSI 4x4, 3.6 V6 4x4	08/2010 →	<b>F8-7856</b>		H=50; d=13.2; D=65
Control Arm-/Trailing Arm Bush	1.6 TDI, 2.0 TDI 16V 4x4		<b>F8-7856</b>		H=50; d=13.2; D=65
Belt Pulley, crankshaft	1.8 TSI, 1.8 TSI 4x4, 2.0 TSI	Number of Ribs: 5; Parameter: 6PK	<b>F8-7880</b>		D=143
Control Arm-/Trailing Arm Bush	1.4 TSI, 1.6 TDI, 1.8 TSI, 1.8 TSI 4x4, 1.9 TDI, 2.0 TDI, 2.0 TDI 16V, 2.0 TDI 4x4, 2.0 TSI, 3.6 FSI 4x4, 3.6 V6 4x4		<b>F8-7902</b>		H=60; d=12; D=42
Control Arm-/Trailing Arm Bush	1.4 TSI, 1.6 TDI, 1.8 TSI, 1.8 TSI 4x4, 1.9 TDI, 2.0 TDI, 2.0 TDI 16V, 2.0 TDI 4x4, 2.0 TSI, 3.6 FSI 4x4, 3.6 V6 4x4		<b>F8-7907</b>		H=45; d=14; D=38
Control Arm-/Trailing Arm Bush	1.4 TSI, 1.6 TDI, 1.8 TSI, 1.8 TSI 4x4, 1.9 TDI, 2.0 TDI, 2.0 TDI 16V, 2.0 TDI 4x4, 2.0 TSI, 3.6 FSI 4x4, 3.6 V6 4x4		<b>F8-7908</b>		H=45; d=12; D=38
Control Arm-/Trailing Arm Bush	1.4 TSI, 1.6 TDI, 1.8 TSI, 1.8 TSI 4x4, 1.9 TDI, 2.0 TDI, 2.0 TDI 16V, 2.0 TDI 4x4, 2.0 TSI, 3.6 FSI 4x4, 3.6 V6 4x4		<b>F8-7909</b>		
Engine Mounting	1.4 TSI		<b>F8-7959</b>		
Engine Mounting	1.4 TSI		<b>F8-7960</b>		
Engine Mounting	2.0 TDI		<b>F8-7962</b>		
Engine Mounting	1.8 TSI, 1.8 TSI 4x4		<b>F8-7963</b>		
Engine Mounting	1.9 TDI	09/2010 →;	<b>F8-7963</b>		
Engine Mounting	1.4 TSI, 1.6 TDI, 1.8 TSI, 1.8 TSI 4x4, 1.9 TDI, 2.0 TDI, 2.0 TDI 16V 4x4, 2.0 TSI		<b>F8-7982</b>		
Engine Mounting	2.0 TDI 16V		<b>F8-7982</b>		
Engine Mounting	2.0 TDI 4x4		<b>F8-8152</b>		
Engine Mounting	2.0 TDI, 2.0 TDI 16V		<b>F8-8152</b>		
<b>SUPERB Estate (3T5)</b>			<b>10/2009 → 05/2015</b>		
Alternator Freewheel Clutch	1.6 TDI, 2.0 TDI, 2.0 TDI 16V, 2.0 TDI 16V 4x4, 2.0 TDI 4x4		<b>F5-1004</b>		
Alternator Freewheel Clutch	1.8 TSI, 1.8 TSI 4x4, 2.0 TSI		<b>F5-1044</b>		
Alternator Freewheel Clutch	1.4 TSI, 1.6 TDI		<b>F5-1064</b>		
Alternator Freewheel Clutch	1.6 TDI, 1.9 TDI, 2.0 TDI, 2.0 TDI 16V, 2.0 TDI 16V 4x4, 2.0 TDI 4x4, 3.6 V6 4x4		<b>F5-1085</b>		
Control Arm-/Trailing Arm Bush	1.4 TSI, 1.6 TDI, 1.8 TSI, 1.8 TSI 4x4, 2.0 TDI, 2.0 TDI 16V, 2.0 TDI 4x4, 2.0 TSI, 3.6 V6 4x4		<b>F8-5633</b>		
Protective Cap/Bellow, shock absorber	All Models	for OE: 1JA, 1JB, 1JC, 1JD; <b>□</b> , <b>Δ</b> , <b>SP</b> , <b>ST</b>	<b>F8-6044</b>		H=160

<b>F5-1004</b>	<b>F5-1044</b>	<b>F5-1064</b>	<b>F5-1085</b>	<b>F8-5633</b>	<b>F8-6044</b>	<b>F8-6284</b>
Ref.Nr.: 038903119T	Ref.Nr.: 06B903119B	Ref.Nr.: 03C903119D	Ref.Nr.: 045903119A	Ref.Nr.: 1K0407182A	Ref.Nr.: 3C0513425	Ref.Nr.: 6N0412249C
<b>F8-7714</b>	<b>F8-7834</b>	<b>F8-7856</b>	<b>F8-7880</b>	<b>F8-7902</b>	<b>F8-7907</b>	<b>F8-7908</b>
Ref.Nr.: 3C0511359B	Ref.Nr.: 1K0412303H	Ref.Nr.: 5C0407183A	Ref.Nr.: 06H105243F	Ref.Nr.: 1K0505171C	Ref.Nr.: 1K0505203A	Ref.Nr.: 1K0505279A
<b>F8-7909</b>	<b>F8-7959</b>	<b>F8-7960</b>	<b>F8-7962</b>	<b>F8-7963</b>	<b>F8-7982</b>	<b>F8-8152</b>
Ref.Nr.: 1K050553 A	Ref.Nr.: 1K0199262CG	Ref.Nr.: 1K0199555L	Ref.Nr.: 1K0199555Q	Ref.Nr.: 3C0199555P	Ref.Nr.: 1K0199868Q	Ref.Nr.: 1K0199555T

Article Description



Article Nr.

Fitting Position



<b>SUPERB Estate (3T5)</b>				<b>10/2009 → 05/2015</b>	
Top Strut Mounting	1.4 TSI, 1.8 TSI, 1.8 TSI 4x4, 2.0 TDI, 2.0 TDI 16V, 2.0 TDI 4x4, 3.6 V6 4x4		<b>F8-6284</b>		
Control Arm-/Trailing Arm Bush	1.4 TSI, 1.8 TSI, 1.8 TSI 4x4, 2.0 TDI, 2.0 TDI 16V, 2.0 TDI 4x4, 3.6 V6 4x4	Aluminium	<b>F8-6424</b>		
Control Arm-/Trailing Arm Bush	1.4 TSI, 1.8 TSI, 1.8 TSI 4x4, 2.0 TDI, 2.0 TDI 16V, 2.0 TDI 4x4, 3.6 V6 4x4	Aluminium	<b>F8-6425</b>		
Engine Mounting	2.0 TDI 16V	BKD	<b>F8-6528</b>		
Anti-Friction Bearing	1.4 TSI, 1.6 TDI, 1.8 TSI, 1.8 TSI 4x4, 1.9 TDI, 2.0 TDI, 2.0 TDI 16V, 2.0 TDI 16V 4x4, 2.0 TDI 4x4, 2.0 TSI, 3.6 V6 4x4	for OE: 2UD, G55, G56;	<b>F8-6569</b>		
Anti-Friction Bearing	1.4 TSI, 1.6 TDI, 1.8 TSI, 1.8 TSI 4x4, 1.9 TDI, 2.0 TDI, 2.0 TDI 16V, 2.0 TDI 16V 4x4, 2.0 TDI 4x4, 2.0 TSI, 3.6 V6 4x4	for OE: G53, G54;	<b>F8-6569</b>		
Anti-Friction Bearing	1.4 TSI, 1.6 TDI, 1.8 TSI, 1.8 TSI 4x4, 1.9 TDI, 2.0 TDI, 2.0 TDI 16V, 2.0 TDI 16V 4x4, 2.0 TDI 4x4, 2.0 TSI, 3.6 V6 4x4		<b>F8-6569</b>		
Top Strut Mounting	All Models		<b>F8-6570</b>		
Belt Pulley, crankshaft	1.6 TDI, 2.0 TDI 16V 4x4	Number of Ribs: 5; Parameter: 6PK	<b>F8-6572</b>		
Belt Pulley, crankshaft	2.0 TDI 16V	CFFB, CLJA; Number of Ribs: 5; Parameter: 6PK	<b>F8-6572</b>		
Belt Pulley, crankshaft	2.0 TDI, 2.0 TDI 4x4	CFGB; Number of Ribs: 5; Parameter: 6PK	<b>F8-6572</b>		
Engine Mounting	1.8 TSI, 1.8 TSI 4x4, 2.0 TSI		<b>F8-6989</b>		
Rubber Buffer, suspension	1.4 TSI, 1.6 TDI, 1.8 TSI, 1.9 TDI, 2.0 TDI, 2.0 TDI 16V, 2.0 TSI	for OE: G02, G07, G15, G50, G51	<b>F8-7131</b>		H=70
Rubber Buffer, suspension	1.8 TSI 4x4, 2.0 TDI 16V 4x4, 2.0 TDI 4x4, 3.6 V6 4x4	for OE: 2UD;	<b>F8-7131</b>		H=70
Protective Cap/Bellow, shock absorber	All Models		<b>F8-7132</b>		H=190
Rubber Buffer, suspension	All Models	for OE: 1JA, 1JB, 1JD;	<b>F8-7140</b>		H=133
Top Strut Mounting	All Models		<b>F8-7603</b>		
Rubber Buffer, suspension	All Models	for OE: G53, G54;	<b>F8-7697</b>		H=55
Rubber Buffer, suspension	All Models	for OE: G55, G56;	<b>F8-7834</b>		H=90
Control Arm-/Trailing Arm Bush	1.4 TSI, 1.8 TSI, 1.8 TSI 4x4, 1.9 TDI, 2.0 TDI, 2.0 TDI 16V, 2.0 TDI 4x4, 2.0 TSI, 3.6 V6 4x4	08/2010 →	<b>F8-7856</b>		H=50; d=13.2; D=65
Control Arm-/Trailing Arm Bush	1.6 TDI, 2.0 TDI 16V 4x4		<b>F8-7856</b>		H=50; d=13.2; D=65
Belt Pulley, crankshaft	1.8 TSI, 1.8 TSI 4x4, 2.0 TSI	Number of Ribs: 5; Parameter: 6PK	<b>F8-7880</b>		D=143
Engine Mounting	1.4 TSI		<b>F8-7960</b>		
Engine Mounting	1.8 TSI, 1.8 TSI 4x4		<b>F8-7963</b>		
Engine Mounting	1.4 TSI, 1.6 TDI, 1.8 TSI, 1.8 TSI 4x4, 1.9 TDI, 2.0 TDI, 2.0 TDI 16V, 2.0 TDI 16V 4x4, 2.0 TSI		<b>F8-7982</b>		
Engine Mounting	2.0 TDI 4x4		<b>F8-8152</b>		

<b>F8-6284</b>	<b>F8-6424</b>	<b>F8-6425</b>	<b>F8-6528</b>	<b>F8-6569</b>	<b>F8-6570</b>	<b>F8-6572</b>
Ref.Nr.: 6N0412249C	Ref.Nr.: 1K0199232G	Ref.Nr.: 1K0199231J	Ref.Nr.: 1K0 199 262 AT	Ref.Nr.: 6N0412249C	Ref.Nr.: 1K0412331C	Ref.Nr.: 038105243L
<b>F8-6989</b>	<b>F8-7131</b>	<b>F8-7132</b>	<b>F8-7140</b>	<b>F8-7603</b>	<b>F8-7697</b>	<b>F8-7834</b>
Ref.Nr.: 1K0199262AM	Ref.Nr.: 1K0412303B	Ref.Nr.: 6N0413175A	Ref.Nr.: 3C0511359	Ref.Nr.: 3C0513353	Ref.Nr.: 1K0412303F	Ref.Nr.: 1K0412303H
<b>F8-7856</b>	<b>F8-7880</b>	<b>F8-7960</b>	<b>F8-7963</b>	<b>F8-7982</b>	<b>F8-8152</b>	
Ref.Nr.: 5C0407183A	Ref.Nr.: 06H105243F	Ref.Nr.: 1K0199555L	Ref.Nr.: 3C0199555P	Ref.Nr.: 1K0199868Q	Ref.Nr.: 1K0199555T	

**Article Description****Article Nr.****Fitting Position**

<b>SUPERB Estate (3T5)</b>				<b>10/2009 → 05/2015</b>	
Engine Mounting	2.0 TDI, 2.0 TDI 16V	6-speed	<b>F8-8152</b>		
<b>YETI (5L)</b>				<b>05/2009 →</b>	
Alternator Freewheel Clutch	1.6 TDI, 2.0 TDI, 2.0 TDI 4x4		<b>F5-1004</b>		
Alternator Freewheel Clutch	1.8 TSI 4x4		<b>F5-1044</b>		
Alternator Freewheel Clutch	1.2 TSI, 1.4 TSI		<b>F5-1064</b>		
Control Arm-Trailing Arm Bush	1.2 TSI, 1.4 TSI, 1.6 TDI, 1.8 TSI 4x4, 2.0 TDI, 2.0 TDI 4x4		<b>F8-5633</b>		
Top Strut Mounting	1.2 TSI, 1.4 TSI, 1.8 TSI 4x4, 2.0 TDI, 2.0 TDI 4x4		<b>F8-6284</b>		
Anti-Friction Bearing	1.2 TSI, 1.4 TSI, 1.6 TDI, 1.8 TSI 4x4, 2.0 TDI, 2.0 TDI 4x4		<b>F8-6569</b>		
Top Strut Mounting	1.2 TSI, 1.4 TSI, 1.6 TDI, 1.8 TSI 4x4, 2.0 TDI, 2.0 TDI 4x4		<b>F8-6570</b>		
Belt Pulley, crankshaft	1.6 TDI, 2.0 TDI, 2.0 TDI 4x4	Number of Ribs: 5; Parameter: 6PK	<b>F8-6572</b>		
Engine Mounting	1.8 TSI 4x4		<b>F8-6989</b>		
Protective Cap/Bellow, shock absorber	1.2 TSI, 1.4 TSI, 1.6 TDI, 1.8 TSI 4x4, 2.0 TDI, 2.0 TDI 4x4		<b>F8-7132</b>		H=190
Rubber Buffer, suspension	1.2 TSI, 1.4 TSI, 1.6 TDI, 1.8 TSI 4x4, 2.0 TDI, 2.0 TDI 4x4	for OE: 1JB, 1JG;	<b>F8-7140</b>		H=133
Top Strut Mounting	1.2 TSI, 1.4 TSI, 1.6 TDI, 1.8 TSI 4x4, 2.0 TDI, 2.0 TDI 4x4		<b>F8-7603</b>		
Rubber Buffer, suspension	1.2 TSI, 1.4 TSI, 1.6 TDI, 1.8 TSI 4x4, 2.0 TDI, 2.0 TDI 4x4	for OE: G02;	<b>F8-7703</b>		H=90; d=25
Rubber Buffer, suspension	1.2 TSI, 1.4 TSI, 1.6 TDI, 1.8 TSI 4x4, 2.0 TDI, 2.0 TDI 4x4	for OE: G06	<b>F8-7834</b>		H=90
Rubber Buffer, suspension	1.2 TSI, 1.4 TSI, 1.6 TDI, 1.8 TSI 4x4, 2.0 TDI, 2.0 TDI 4x4	for OE: 1JL	<b>F8-7836</b>		H=143
Control Arm-Trailing Arm Bush	1.2 TSI, 1.4 TSI, 1.8 TSI 4x4, 2.0 TDI, 2.0 TDI 4x4	08/2010 →	<b>F8-7856</b>		H=50; d=13.2; D=65
Control Arm-Trailing Arm Bush	1.6 TDI, 2.0 TDI		<b>F8-7856</b>		H=50; d=13.2; D=65
Belt Pulley, crankshaft	1.8 TSI 4x4	Number of Ribs: 5; Parameter: 6PK	<b>F8-7880</b>		D=143
Control Arm-Trailing Arm Bush	1.2 TSI, 1.4 TSI, 1.6 TDI, 1.8 TSI 4x4, 2.0 TDI, 2.0 TDI 4x4		<b>F8-7909</b>		
Engine Mounting	1.4 TSI		<b>F8-7960</b>		
Engine Mounting	1.2 TSI, 1.4 TSI, 1.6 TDI, 1.8 TSI 4x4, 2.0 TDI, 2.0 TDI 4x4		<b>F8-7982</b>		
Engine Mounting	2.0 TDI 4x4	CFJA	<b>F8-7982</b>		
Engine Mounting	2.0 TDI 4x4		<b>F8-8152</b>		
Engine Mounting	2.0 TDI, 2.0 TDI 4x4		<b>F8-8152</b>		

<b>F5-1004</b>	<b>F5-1044</b>	<b>F5-1064</b>	<b>F8-5633</b>	<b>F8-6284</b>	<b>F8-6569</b>	<b>F8-6570</b>
Ref.Nr.: 038903119T	Ref.Nr.: 06B903119B	Ref.Nr.: 03C903119D	Ref.Nr.: 1K0407182A	Ref.Nr.: 6N0412249C	Ref.Nr.: 6N0412249C	Ref.Nr.: 1K0412331C
<b>F8-6572</b>	<b>F8-6989</b>	<b>F8-7132</b>	<b>F8-7140</b>	<b>F8-7603</b>	<b>F8-7703</b>	<b>F8-7834</b>
Ref.Nr.: 038105243L	Ref.Nr.: 1K0199262AM	Ref.Nr.: 6N0413175A	Ref.Nr.: 3C0511359	Ref.Nr.: 3C0513353	Ref.Nr.: 1K0412303G	Ref.Nr.: 1K0412303H
<b>F8-7836</b>	<b>F8-7856</b>	<b>F8-7880</b>	<b>F8-7909</b>	<b>F8-7960</b>	<b>F8-7982</b>	<b>F8-8152</b>
Ref.Nr.: 1T0511359	Ref.Nr.: 5C0407183A	Ref.Nr.: 06H105243F	Ref.Nr.: 1K0505553 A	Ref.Nr.: 1K0199555L	Ref.Nr.: 1K0199868Q	Ref.Nr.: 1K0199555T

<b>Article Description</b>			<b>Article Nr.</b>	<b>Fitting Position</b>	
----------------------------	--	--	--------------------	-------------------------	--

<b>CABRIO (450)</b>			<b>03/2000 → 01/2004</b>		
Dust Cover Kit, shock absorber	All Models		AK-735268		
Rubber Buffer, suspension	All Models		AK-735269		
Anti-Friction Bearing	All Models		F8-3039		H=14; d1=14; D=45
Engine Mounting	All Models		F8-6426		
Engine Mounting	0.8 CDI		F8-6427		
Top Strut Mounting	All Models		F8-6514		
Top Strut Mounting	All Models		F8-6551		
Spring Cap	All Models		F8-6552		
Control Arm-/Trailing Arm Bush	All Models		F8-6730		d=12; Thick. [mm]=36.8
Rubber Buffer, suspension	0.6 , 0.7		F8-7591		H=34
<b>CITY-COUPE (450)</b>			<b>07/1998 → 01/2004</b>		
Dust Cover Kit, shock absorber	All Models		AK-735268		
Rubber Buffer, suspension	All Models		AK-735269		
Anti-Friction Bearing	All Models		F8-3039		H=14; d1=14; D=45
Engine Mounting	All Models		F8-6426		
Engine Mounting	0.8 CDI		F8-6427		
Top Strut Mounting	All Models		F8-6514		
Top Strut Mounting	All Models		F8-6551		
Spring Cap	All Models		F8-6552		
Control Arm-/Trailing Arm Bush	All Models		F8-6730		d=12; Thick. [mm]=36.8
Rubber Buffer, suspension	0.6		F8-7591		H=34
<b>CROSSBLADE (450)</b>			<b>06/2002 → 12/2003</b>		
Anti-Friction Bearing	All Models		F8-3039		H=14; d1=14; D=45
Top Strut Mounting	All Models		F8-6514		
Top Strut Mounting	All Models		F8-6551		
Spring Cap	All Models		F8-6552		
Control Arm-/Trailing Arm Bush	All Models		F8-6730		d=12; Thick. [mm]=36.8
Repair Kit, suspension strut	All Models		F8-8215		
<b>FORFOUR (454)</b>			<b>01/2004 → 06/2006</b>		
Dust Cover Kit, shock absorber	All Models		AK-735272		
Dust Cover Kit, shock absorber	All Models		AK-735273		
Alternator Freewheel Clutch	1.5 CDI		F5-1121		

<b>AK-735268</b>	<b>AK-735269</b>	<b>AK-735272</b>	<b>AK-735273</b>	<b>F5-1121</b>	<b>F8-3039</b>	<b>F8-6426</b>
Ref.Nr.: 6861C003	Ref.Nr.: 6805V001	Ref.Nr.: 4543230244	Ref.Nr.: 4543250044	Ref.Nr.: 6681550215	Ref.Nr.: 357412249A	Ref.Nr.: 03077V008000
<b>F8-6427</b>	<b>F8-6514</b>	<b>F8-6551</b>	<b>F8-6552</b>	<b>F8-6730</b>	<b>F8-7591</b>	<b>F8-8215</b>
Ref.Nr.: 05811V006000	Ref.Nr.: 0008236V00300	Ref.Nr.: 6697V004	Ref.Nr.: 0006651V004	Ref.Nr.: 0014141V00100	Ref.Nr.: 0009975V003	Ref.Nr.: A4503300051

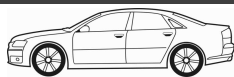
**Article Description****Article Nr.****Fitting Position**

<b>FORTWO Cabrio (450)</b>		<b>01/2004 → 01/2007</b>	
Dust Cover Kit, shock absorber	All Models	AK-735268	
Rubber Buffer, suspension	All Models	AK-735269	
Anti-Friction Bearing	All Models	F8-3039	H=14; d1=14; D=45
Engine Mounting	All Models	F8-6426	
Engine Mounting	0.8 CDI	F8-6427	
Top Strut Mounting	All Models	F8-6514	
Top Strut Mounting	All Models	F8-6551	
Spring Cap	All Models	F8-6552	
Control Arm-/Trailing Arm Bush	All Models	F8-6730	d=12; Thick. [mm]=36.8
Rubber Buffer, suspension	0.7	F8-7591	H=34
Repair Kit, suspension strut	All Models	F8-8215	
<b>FORTWO Cabrio (451)</b>		<b>01/2007 → 12/2012</b>	
Dust Cover Kit, shock absorber	All Models	AK-735270	
Anti-Friction Bearing	All Models	F8-3039	H=14; d1=14; D=45
Top Strut Mounting	All Models	F8-6514	
Repair Kit, suspension strut	0.8 CDI , 1.0 , 1.0 Brabus , 1.0 Turbo , 1.0 Turbo Brabus , electric drive	F8-8215	
<b>FORTWO Coupe (450)</b>		<b>01/2004 → 01/2007</b>	
Dust Cover Kit, shock absorber	0.7 , 0.8 CDI	AK-735268	
Rubber Buffer, suspension	0.7 , 0.8 CDI	AK-735269	
Anti-Friction Bearing	0.7 , 0.8 CDI	F8-3039	H=14; d1=14; D=45
Engine Mounting	0.7	F8-6426	
Engine Mounting	0.8 CDI	F8-6427	
Top Strut Mounting	0.7 , 0.8 CDI	F8-6514	
Top Strut Mounting	0.7 , 0.8 CDI	F8-6551	
Spring Cap	0.7 , 0.8 CDI	F8-6552	
Control Arm-/Trailing Arm Bush	0.7 , 0.8 CDI	F8-6730	d=12; Thick. [mm]=36.8
Rubber Buffer, suspension	0.7	F8-7591	H=34
Repair Kit, suspension strut	0.7 , 0.8 CDI	F8-8215	
<b>FORTWO Coupe (451)</b>		<b>01/2007 → 12/2012</b>	
Dust Cover Kit, shock absorber	0.8 CDI , 1.0, 1.0 Brabus , 1.0 Turbo , 1.0 Turbo Brabus , electric drive, electric drive Brabus	AK-735270	
Anti-Friction Bearing	0.8 CDI , 1.0, 1.0 Brabus , 1.0 Turbo , 1.0 Turbo Brabus , electric drive, electric drive Brabus	F8-3039	H=14; d1=14; D=45



<b>Article Description</b>			<b>Article Nr.</b>	<b>Fitting Position</b>	
----------------------------	--	--	--------------------	-------------------------	--

<b>FORTWO Coupe (451)</b>			<b>01/2007 → 12/2012</b>		
Top Strut Mounting	0.8 CDI , 1.0 , 1.0 Brabus , 1.0 Turbo , 1.0 Turbo Brabus , electric drive, electric drive Brabus		<b>F8-6514</b>		
Repair Kit, suspension strut	0.8 CDI , 1.0 , 1.0 Brabus , 1.0 Turbo , 1.0 Turbo Brabus , electric drive		<b>F8-8215</b>		
<b>ROADSTER (452)</b>			<b>04/2003 → 11/2005</b>		
Dust Cover Kit, shock absorber	All Models		<b>AK-735271</b>		
Anti-Friction Bearing	All Models		<b>F8-3039</b>		H=14; d1=14; D=45
Engine Mounting	All Models		<b>F8-6426</b>		
Top Strut Mounting	All Models		<b>F8-6514</b>		
Control Arm-/Trailing Arm Bush	All Models		<b>F8-6730</b>		d=12; Thick. [mm]=36.8
Rubber Buffer, suspension	All Models		<b>F8-7591</b>		H=34
Repair Kit, suspension strut	All Models		<b>F8-8215</b>		
<b>ROADSTER Coupe (452)</b>			<b>04/2003 → 11/2005</b>		
Dust Cover Kit, shock absorber	All Models		<b>AK-735271</b>		
Anti-Friction Bearing	All Models		<b>F8-3039</b>		H=14; d1=14; D=45
Top Strut Mounting	All Models		<b>F8-6514</b>		
Control Arm-/Trailing Arm Bush	All Models		<b>F8-6730</b>		d=12; Thick. [mm]=36.8
Rubber Buffer, suspension	All Models		<b>F8-7591</b>		H=34
Repair Kit, suspension strut	All Models		<b>F8-8215</b>		

<b>AK-735271</b>	<b>F8-3039</b>	<b>F8-6426</b>	<b>F8-6514</b>	<b>F8-6730</b>	<b>F8-7591</b>	<b>F8-8215</b>
Ref.Nr.: 0006862V004	Ref.Nr.: 357412249A	Ref.Nr.: 03077V008000	Ref.Nr.: 0008236V00300	Ref.Nr.: 0014141V00100	Ref.Nr.: 0009975V003	Ref.Nr.: A4503300051



**Article Description****Article Nr.****Fitting Position**

<b>FORESTER (SF)</b>		<b>08/1997 → 09/2002</b>	
Dust Cover Kit, shock absorber	2.0, 2.0 S Turbo	AK-735141	
Dust Cover Kit, shock absorber	2.0, 2.0 S Turbo	AK-735143	
<b>FORESTER (SG)</b>		<b>09/2002 → 08/2005</b>	
Dust Cover Kit, shock absorber	2.0, 2.0 S Turbo, 2.0 X, 2.5, 2.5 All-wheel Drive, 2.5 RX Nato AWD, 2.5 XT	AK-735441	
<b>FORESTER (SH)</b>		<b>01/2008 →</b>	
Control Arm-/Trailing Arm Bush	2.0, 2.0 D, 2.5	F8-7987	H=57; d=19; D=60
<b>IMPREZA Saloon (GC)</b>		<b>08/1992 → 12/2000</b>	
Dust Cover Kit, shock absorber	1.6 i, 1.6 i 4WD, 1.8 i 4WD, 2.0 AWD, 2.0 i 4WD, 2.0 Turbo GT 4WD, 2.2 GX AWD	AK-735140	
Dust Cover Kit, shock absorber	1.6 i, 1.6 i 4WD, 1.8 i 4WD, 2.0 AWD, 2.0 i 4WD, 2.0 Turbo GT 4WD, 2.2 GX AWD	AK-735142	
<b>IMPREZA Estate (GF)</b>		<b>08/1992 → 12/2000</b>	
Dust Cover Kit, shock absorber	1.5 L, 1.6, 1.6 i, 1.6 i 4WD, 1.8 i 4WD, 2.0 16V AWD, 2.0 4WD, 2.0 i Turbo 4WD, 2.0 Turbo GT 4WD, 2.2 GX AWD	AK-735140	
Dust Cover Kit, shock absorber	1.5 L, 1.6, 1.6 i, 1.6 i 4WD, 1.8 i 4WD, 2.0 16V AWD, 2.0 4WD, 2.0 i Turbo 4WD, 2.0 Turbo GT 4WD, 2.2 GX AWD	AK-735144	
<b>IMPREZA Estate (GG)</b>		<b>12/2000 → 06/2007</b>	
Dust Cover Kit, shock absorber	1.5, 1.5 AWD, 1.6, 2.0, 2.0 AWD, 2.0 R, 2.2, 2.5 AWD	AK-735441	
<b>IMPREZA Saloon (GD)</b>		<b>12/2000 → 09/2005</b>	
Dust Cover Kit, shock absorber	1.5, 1.5 AWD, 1.6 AWD, 2.0, 2.0 All-wheel Drive, 2.0 AWD, 2.0 R, 2.2, 2.5 All-wheel Drive, 2.5 AWD	AK-735441	
<b>IMPREZA Hatchback (GR, GH, G3)</b>		<b>01/2008 →</b>	
Control Arm-/Trailing Arm Bush	1.5 All-wheel Drive, 2.0, 2.0 All-wheel Drive, 2.0 D All-wheel Drive, 2.5, 2.5 All-wheel Drive, 2.5 STI CS400	F8-7987	H=57; d=19; D=60
<b>IMPREZA Saloon (GR)</b>		<b>01/2011 →</b>	
Control Arm-/Trailing Arm Bush	2.0 AWD	F8-7987	H=57; d=19; D=60
<b>JUSTY III (G3X)</b>		<b>09/2003 →</b>	
Control Arm-/Trailing Arm Bush	All Models	F8-7857	
Repair Kit, link	All Models	F8-7857S	
<b>LEGACY Mk III (BE, BH)</b>		<b>06/2002 → 08/2003</b>	
Control Arm-/Trailing Arm Bush	2.0 AWD	F8-7987	H=57; d=19; D=60

<b>AK-735140</b>	<b>AK-735141</b>	<b>AK-735142</b>	<b>AK-735143</b>	<b>AK-735144</b>	<b>AK-735441</b>	<b>F8-7857</b>
Ref.Nr.:	Ref.Nr.: 20321AA101	Ref.Nr.: 20371FE110	Ref.Nr.: 20371FC000	Ref.Nr.: 20372AA031	Ref.Nr.: 20321AA201	Ref.Nr.: 9209466
<b>F8-7857S</b>	<b>F8-7987</b>					
Ref.Nr.: 42451-76G00	Ref.Nr.: 20204AG011					

Article Description



Article Nr.

Fitting Position



**LEGACY Mk III Estate (BE, BH)**

06/2002 → 08/2003

Control Arm-/Trailing Arm Bush	2.0 AWD		<b>F8-7987</b>	⊕ ⊕	H=57; d=19; D=60
--------------------------------	---------	--	----------------	-----	------------------

**LEGACY IV (BL, BP)**

09/2003 →

Dust Cover Kit, shock absorber	2.0, 2.5, 3.0 R	Universal	<b>AK-735140</b>	⊕ ⊕	
Control Arm-/Trailing Arm Bush	2.0, 2.0 D, 2.5 i, 3.0 R		<b>F8-7987</b>	⊕ ⊕	H=57; d=19; D=60
Control Arm-/Trailing Arm Bush	2.5 i		<b>F8-8124</b>	⊕ ⊕	

**LEGACY IV Estate (BL, BP, B13\_)**

09/2003 →

Dust Cover Kit, shock absorber	2.0, 2.5, 3.0 R	Universal	<b>AK-735140</b>	⊕ ⊕	
Control Arm-/Trailing Arm Bush	2.0, 2.0 D, 2.5 i, 3.0 R		<b>F8-7987</b>	⊕ ⊕	H=57; d=19; D=60

**OUTBACK (BL, BP)**

11/2003 → 09/2009

Dust Cover Kit, shock absorber	2.5, 3.0	Universal	<b>AK-735140</b>	⊕ ⊕	
--------------------------------	----------	-----------	------------------	-----	--

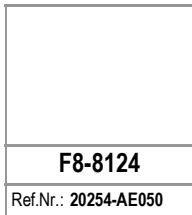

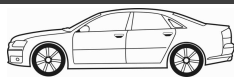
**Article Description****Article Nr.****Fitting Position**

<b>ALTO (SS80)</b>		<b>06/1982 → 08/1984</b>	
Control Arm-/Trailing Arm Bush	All Models	F8-6585	
<b>ALTO Mk II (EC)</b>		<b>01/1986 → 12/1988</b>	
Control Arm-/Trailing Arm Bush	All Models	F8-6585	
<b>ALTO Mk III (EF)</b>		<b>09/1994 → 09/1998</b>	
Dust Cover Kit, shock absorber	1.0	AK-735274	
Dust Cover Kit, shock absorber	1.0	AK-735275	
Control Arm-/Trailing Arm Bush	1.0	F8-6585	
Stabiliser Mounting	1.0	F8-8125	
<b>ALTO Mk IV (FF)</b>		<b>09/2004 → 12/2008</b>	
Dust Cover Kit, shock absorber	All Models	AK-735274	
Dust Cover Kit, shock absorber	All Models	AK-735276	
Control Arm-/Trailing Arm Bush	All Models	F8-6585	
<b>ALTO (HA25, HA35)</b>		<b>11/2011 →</b>	
Stabiliser Mounting	0.7	F8-8125	
<b>BALENO (EG)</b>		<b>07/1995 → 05/2002</b>	
Dust Cover Kit, shock absorber	1.3, 1.3 i 16V, 1.6 i 16V, 1.6 i 16V 4x4, 1.8 GTX, 1.9 TD	AK-735279	
Dust Cover Kit, shock absorber	1.3, 1.3 i 16V, 1.6 i 16V, 1.6 i 16V 4x4, 1.8 GTX, 1.9 TD	AK-735280	
<b>BALENO Estate (EG)</b>		<b>08/1996 → 05/2002</b>	
Dust Cover Kit, shock absorber	1.3 16V, 1.6 i 16V, 1.6 i 16V 4x4, 1.8 i 16V, 1.9 TD	AK-735279	
Dust Cover Kit, shock absorber	1.3 16V, 1.6 i 16V, 1.6 i 16V 4x4, 1.8 i 16V, 1.9 TD	AK-735280	
<b>BALENO Hatchback (EG)</b>		<b>07/1995 → 05/2002</b>	
Dust Cover Kit, shock absorber	1.3, 1.3 i 16V, 1.6 i 16V, 1.6 i 16V 4x4, 1.8 GTX, 1.9 TD	AK-735279	
Dust Cover Kit, shock absorber	1.3, 1.3 i 16V, 1.6 i 16V, 1.6 i 16V 4x4, 1.8 GTX, 1.9 TD	AK-735280	
<b>CARRY Box (ST90V)</b>		<b>11/1980 → 10/1985</b>	
Control Arm-/Trailing Arm Bush	All Models	F8-6585	
<b>GRAND VITARA I (FT)</b>		<b>03/1998 → 09/2005</b>	
Dust Cover Kit, shock absorber	1.6, 2.0, 2.0 HDI 110 16V, 2.0 TD Intercooler, 2.5 V6 24V, 2.7 XL-7	AK-735281	

<b>AK-735274</b>	<b>AK-735275</b>	<b>AK-735276</b>	<b>AK-735279</b>	<b>AK-735280</b>	<b>AK-735281</b>	<b>F5-1020</b>
Ref.Nr.: 4211170B11	Ref.Nr.: 4225150A00	Ref.Nr.: 4225175F90	Ref.Nr.: 4193154G00	Ref.Nr.: 4193154G00	Ref.Nr.: 4185065D00	Ref.Nr.: 31771-68D01
<b>F8-6585</b>	<b>F8-8125</b>					
Ref.Nr.: 96 380 613	Ref.Nr.: 4243170B42					

Article Description



Article Nr.

Fitting Position



<b>GRAND VITARA I (FT)</b>		03/1998 → 09/2005	
Alternator Freewheel Clutch	2.0, 2.0 All-wheel Drive, 2.0 HDI 110, 2.0 HDI 110 16V, 2.0 TD All-wheel Drive, 2.0 TD Intercooler	F5-1020	
Alternator Freewheel Clutch	2.0 HDI 110 16V	F5-1039	
Top Strut Mounting	1.6, 2.0, 2.0 HDI 110 16V, 2.0 TD Intercooler, 2.5 V6 24V	F8-5951	
Control Arm-/Trailing Arm Bush	1.6, 2.0, 2.0 HDI 110, 2.0 HDI 110 16V, 2.0 TD Intercooler, 2.5 V6 24V, 2.7 XL-7	F8-8222	
Control Arm-/Trailing Arm Bush	1.6, 2.0, 2.0 HDI 110, 2.0 HDI 110 16V, 2.0 TD Intercooler, 2.5 V6 24V, 2.7 XL-7	F8-8223	
<b>GRAND VITARA II (JT)</b>		04/2005 → 02/2015	
Dust Cover Kit, shock absorber	1.6 All-wheel Drive, 1.9 DDiS, 2.0 All-wheel Drive	AK-735282	
Alternator Freewheel Clutch	2.0 All-wheel Drive	F5-1020	
Alternator Freewheel Clutch	2.0 All-wheel Drive	F5-1039	
<b>IGNIS (FH)</b>		10/2000 → 09/2003	
Dust Cover Kit, shock absorber	All Models	AK-735274	
Control Arm-/Trailing Arm Bush	All Models	F8-6585	
Control Arm-/Trailing Arm Bush	All Models	F8-7857	
Repair Kit, link	All Models	F8-7857S	
Stabiliser Mounting	All Models	F8-8125	
<b>IGNIS II</b>		09/2003 →	
Alternator Freewheel Clutch	1.3 DDiS	F5-1045	
Control Arm-/Trailing Arm Bush	1.3, 1.3 DDiS, 1.5, 1.5 4x4, 1.5 Sport	F8-6585	
Control Arm-/Trailing Arm Bush	All Models	F8-7857	
Repair Kit, link	All Models	F8-7857S	
<b>LIANA (ER)</b>		03/2002 →	
Dust Cover Kit, shock absorber	1.3, 1.4 DDiS, 1.6, 1.6 4WD, 1.6 i	AK-735277	
Dust Cover Kit, shock absorber	1.3, 1.4 DDiS, 1.6, 1.6 4WD, 1.6 i	AK-735278	
<b>LIANA Estate (ER)</b>		07/2001 → 12/2007	
Dust Cover Kit, shock absorber	1.3, 1.4 DDiS, 1.6, 1.6 4WD, 1.6 i, 1.8 i	AK-735277	
Dust Cover Kit, shock absorber	1.3, 1.4 DDiS, 1.6, 1.6 4WD, 1.6 i, 1.8 i	AK-735278	
<b>SPLASH</b>		01/2008 →	
Alternator Freewheel Clutch	1.3 CDTI	F5-1045	
Top Strut Mounting	1.0, 1.2, 1.2 VVT, 1.3 CDTI	F8-7624	

<b>AK-735274</b>	<b>AK-735277</b>	<b>AK-735278</b>	<b>AK-735282</b>	<b>F5-1020</b>	<b>F5-1039</b>	<b>F5-1045</b>
Ref.Nr.: 4211170B11	Ref.Nr.: 4225154G10	Ref.Nr.: 4193154G00	Ref.Nr.: 4193165J00	Ref.Nr.: 31771-68D01	Ref.Nr.: 3177168D01	Ref.Nr.: 77362721
<b>F8-5951</b>	<b>F8-6585</b>	<b>F8-7624</b>	<b>F8-7857</b>	<b>F8-7857S</b>	<b>F8-8125</b>	<b>F8-8222</b>
Ref.Nr.: 41810-60A01	Ref.Nr.: 96 380 613	Ref.Nr.: 41710-57K00	Ref.Nr.: 9209466	Ref.Nr.: 42451-76G00	Ref.Nr.: 4243170B42	Ref.Nr.: 45261-65D01
<b>F8-8223</b>						
Ref.Nr.: 45262-65D01						

**Article Description****Article Nr.****Fitting Position**

<b>SUPER CARRY Bus (ED)</b>			<b>10/1985 → 03/1999</b>	
Control Arm-/Trailing Arm Bush	1.0		<b>F8-6585</b>	
<b>SWIFT (AA)</b>			<b>10/1983 → 12/1989</b>	
Control Arm-/Trailing Arm Bush	All Models		<b>F8-5288</b>	
Control Arm-/Trailing Arm Bush	All Models		<b>F8-5289</b>	
<b>SWIFT Convertible (SF413)</b>			<b>09/1991 → 10/1996</b>	
Control Arm-/Trailing Arm Bush	All Models		<b>F8-5288</b>	
Control Arm-/Trailing Arm Bush	All Models		<b>F8-5289</b>	
Repair Kit, suspension strut	All Models	with add-on material	<b>F8-5950</b>	
<b>SWIFT Mk II Hatchback (EA, MA)</b>			<b>03/1989 → 12/2005</b>	
Control Arm-/Trailing Arm Bush	1.0, 1.0 i, 1.3, 1.3 4WD, 1.3 GTI		<b>F8-5288</b>	
Control Arm-/Trailing Arm Bush	1.0, 1.0 i, 1.3, 1.3 4WD, 1.3 GTI		<b>F8-5289</b>	
Repair Kit, suspension strut	1.0, 1.0 i, 1.3, 1.3 4WD, 1.3 GTI	with add-on material	<b>F8-5950</b>	
<b>SWIFT Mk II Saloon (AH, AJ)</b>			<b>03/1989 → 05/2001</b>	
Control Arm-/Trailing Arm Bush	All Models		<b>F8-5288</b>	
Control Arm-/Trailing Arm Bush	All Models		<b>F8-5289</b>	
Repair Kit, suspension strut	All Models	with add-on material	<b>F8-5950</b>	
<b>SWIFT III (MZ, EZ)</b>			<b>02/2005 →</b>	
Alternator Freewheel Clutch	1.3 DDiS		<b>F5-1045</b>	
Anti-Friction Bearing	1.3, 1.3 4x4, 1.5, 1.6		<b>F8-6266</b>	
<b>SX4 (EY, GY)</b>			<b>06/2006 →</b>	
Control Arm-/Trailing Arm Bush	1.5, 1.5 VVT, 1.6, 1.6 DDiS, 1.6 VVT, 1.6 VVT 4x4, 1.9 DDiS, 1.9 DDiS 4x4, 2.0, 2.0 4x4, 2.0 DDiS, 2.0 DDiS 4x4		<b>F8-6448</b>	
Control Arm-/Trailing Arm Bush	1.5, 1.5 VVT, 1.6, 1.6 DDiS, 1.6 VVT, 1.6 VVT 4x4, 1.9 DDiS, 1.9 DDiS 4x4, 2.0, 2.0 4x4, 2.0 DDiS, 2.0 DDiS 4x4		<b>F8-6449</b>	
<b>SX4 Saloon (GY)</b>			<b>10/2007 →</b>	
Control Arm-/Trailing Arm Bush	1.6		<b>F8-6448</b>	
Control Arm-/Trailing Arm Bush	1.6		<b>F8-6449</b>	











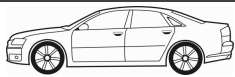























<b>F5-1045</b>	<b>F8-5288</b>	<b>F8-5289</b>	<b>F8-5950</b>	<b>F8-6266</b>	<b>F8-6448</b>	<b>F8-6449</b>
Ref.Nr.: 77362721	Ref.Nr.: 4554060B02	Ref.Nr.: 4553070C00	Ref.Nr.: 4171060B00	Ref.Nr.: 5035C2	Ref.Nr.: 45261-79J00	Ref.Nr.: 45201-79J00
<b>F8-6585</b>						
Ref.Nr.: 96 380 613						

Article Description			Article Nr.	Fitting Position	
---------------------	--	--	-------------	------------------	--

<b>VITARA (ET, TA)</b>			<b>07/1988 → 03/1998</b>		
Alternator Freewheel Clutch	2.0 TD Intercooler		<b>F5-1039</b>		
Top Strut Mounting	1.6, 1.6 i 16V, 1.9 D, 2.0 16V, 2.0 TD, 2.0 TD Intercooler, 2.0 V6 24V, 2.5 V6 24V		<b>F8-5951</b>		
<b>VITARA Cabrio (ET, TA)</b>			<b>07/1988 → 03/1999</b>		
Top Strut Mounting	1.6, 1.6 i 16V, 1.9 D, 2.0 16V		<b>F8-5951</b>		
<b>WAGON R</b>			<b>07/2003 → 08/2005</b>		
Dust Cover Kit, shock absorber	1.0, 1.2		<b>AK-735274</b>		
Dust Cover Kit, shock absorber	1.0, 1.2		<b>AK-735283</b>		
Control Arm-/Trailing Arm Bush	All Models		<b>F8-7857</b>		
Repair Kit, link	All Models		<b>F8-7857S</b>		
<b>WAGON R+ (EM)</b>			<b>02/1998 → 05/2000</b>		
Dust Cover Kit, shock absorber	All Models		<b>AK-735274</b>		
Dust Cover Kit, shock absorber	All Models		<b>AK-735283</b>		
Control Arm-/Trailing Arm Bush	All Models		<b>F8-6585</b>		
Stabiliser Mounting	All Models		<b>F8-8125</b>		
<b>WAGON R+ (MM)</b>			<b>05/2000 → 07/2005</b>		
Alternator Freewheel Clutch	1.3 DDiS		<b>F5-1045</b>		
Control Arm-/Trailing Arm Bush	All Models		<b>F8-7857</b>		
Repair Kit, link	All Models		<b>F8-7857S</b>		
<b>X-90 (EL)</b>			<b>09/1995 → 12/1997</b>		
Top Strut Mounting	All Models		<b>F8-5951</b>		
<b>ALTO (HA12, HA23)</b>			<b>10/1998 → 06/2002</b>		
Dust Cover Kit, shock absorber	1.0		<b>AK-735274</b>		
Dust Cover Kit, shock absorber	1.0		<b>AK-735275</b>		
Control Arm-/Trailing Arm Bush	All Models		<b>F8-6585</b>		
Stabiliser Mounting	All Models		<b>F8-8125</b>		
<b>SX4 S-Cross</b>			<b>08/2013 →</b>		
Control Arm-/Trailing Arm Bush	1.6, 1.6 4x4, 1.6 DDiS, 1.6 DDiS 4x4		<b>F8-6448</b>		
Control Arm-/Trailing Arm Bush	1.6, 1.6 4x4, 1.6 DDiS, 1.6 DDiS 4x4		<b>F8-6449</b>		

<b>AK-735274</b>	<b>AK-735275</b>	<b>AK-735283</b>	<b>F5-1039</b>	<b>F5-1045</b>	<b>F8-5951</b>	<b>F8-6448</b>
Ref.Nr.: 4211170B11	Ref.Nr.: 4225150A00	Ref.Nr.: 4225175F90	Ref.Nr.: 3177168D01	Ref.Nr.: 77362721	Ref.Nr.: 41810-60A01	Ref.Nr.: 45261-79J00
<b>F8-6449</b>	<b>F8-6585</b>	<b>F8-7857</b>	<b>F8-7857S</b>	<b>F8-8125</b>		
Ref.Nr.: 45201-79J00	Ref.Nr.: 96 380 613	Ref.Nr.: 9209466	Ref.Nr.: 42451-76G00	Ref.Nr.: 4243170B42		



Article Description				Article Nr.	Fitting Position	
<b>1307-1510</b>						<b>07/1975 → 04/1984</b>
Bellow Set, drive shaft	1510 1.6, Simca 1510 1.4, Simca 1510 1.6			<b>MK-850850</b>	  	
Bellow Set, drive shaft	Simca 1307 1.3, Simca 1307 1.3S, Simca 1308 1.4, Simca 1510 1.6			<b>MK-850850</b>	  	
<b>EXPRESS 1000 -1500 Bus</b>						<b>07/1987 → 10/1990</b>
Belt Pulley, crankshaft	1.9 D			<b>F8-5646</b>		
<b>EXPRESS 1000 -1800 Van</b>						<b>07/1987 → 10/1990</b>
Belt Pulley, crankshaft	1.9 D			<b>F8-5646</b>		
<b>HORIZON</b>						<b>02/1978 → 06/1986</b>
Bellow Set, drive shaft	1.3, 1.4, 1.6, 1.9 Diesel			<b>MK-850850</b>	  	
<b>SAMBA (51A)</b>						<b>01/1981 → 10/1986</b>
Dust Cover Kit, shock absorber	All Models			<b>AK-735010</b>	  	
<b>SIMCA 1100 Break/Tourisme</b>						<b>10/1976 → 01/1980</b>
Bellow Set, drive shaft	1.1			<b>MK-850850</b>	  	
<b>SIMCA 1100 Hatchback</b>						<b>11/1973 → 01/1980</b>
Bellow Set, drive shaft	1.1 LE,LX,GLS,ES			<b>MK-850850</b>	  	
Bellow Set, drive shaft	1.1 LS,GLS			<b>MK-850850</b>	  	
<b>SOLARA</b>						<b>02/1980 → 07/1986</b>
Bellow Set, drive shaft	1.6			<b>MK-850850</b>	  	

		
<b>AK-735010</b>	<b>F8-5646</b>	<b>MK-850850</b>
Ref.Nr.:	Ref.Nr.: 0515K9	Ref.Nr.: 329373

Article Description		Article Nr.		Fitting Position	
<b>4 RUNNER (RN10_, VZN13_, VZN10_, RN13_)</b>				07/1990 → 03/1996	
Stabiliser Mounting	3.4 i 4x4	F8-8064			
Stabiliser Mounting	3.0 V6	F8-8104		d=18	
<b>4 RUNNER (KZN18_, VZN18_, RZN18_)</b>				11/1995 → 11/2002	
Alternator Freewheel Clutch	4.0 VVTi	F5-1074			
Stabiliser Mounting	3.4	F8-8064			
<b>ALPHARD (ATH1_, MNH1_, ANH1_)</b>				09/2003 → 04/2008	
Alternator Freewheel Clutch	2.4, 2.4 4x4	F5-1073			
<b>ALPHARD / VELLFIRE (GGH2_, ANH2_, ATH2_)</b>				04/2008 → 12/2014	
Alternator Freewheel Clutch	2.4, 2.4 4WD	F5-1073			
Alternator Freewheel Clutch	3.5, 3.5 4WD	F5-1074			
<b>AURION (GSV4_, ACV4_)</b>				03/2006 → 09/2011	
Alternator Freewheel Clutch	2.4	F5-1073			
Alternator Freewheel Clutch	3.5	F5-1074			
<b>AURIS (ZWE18_, NZE18_, ZRE18_)</b>				10/2012 →	
Alternator Freewheel Clutch	2.0 D-4D	F5-1084			
<b>AURIS (NRE15_, ZZE15_, ADE15_, ZRE15_, NDE15_)</b>				03/2007 → 09/2012	
Dust Cover Kit, shock absorber	1.4 D-4D, 1.4 VVTi, 1.6 VVTi, 2.0 D-4D, 2.2 D	AK-735284			
Alternator Freewheel Clutch	2.0 D-4D, 2.2 D	F5-1084			
Alternator Freewheel Clutch	2.0 D-4D, 2.2 D	F5-1152			
Belt Pulley, crankshaft	2.0 D-4D, 2.2 D	F8-7868			
<b>AVALON Saloon (GSX3_)</b>				01/2005 →	
Alternator Freewheel Clutch	3.5 VVTi	F5-1074			
<b>AVENSIS (_T22_)</b>				09/1997 → 02/2003	
Dust Cover Kit, shock absorber	1.6, 1.6 VVT-i, 1.8, 1.8 VVT-i, 2.0, 2.0 D-4D, 2.0 TD, 2.0 VVT-i	AK-735087			
Dust Cover Kit, shock absorber	1.6, 1.6 VVT-i, 1.8, 1.8 VVT-i, 2.0, 2.0 D-4D, 2.0 TD, 2.0 VVT-i	AK-735111			
Belt Pulley, crankshaft	1.8 VVT-i	F8-6388		d=25; D=135.1	
Belt Pulley, crankshaft	1.8	F8-6389		d=25; D=137.2	
Control Arm-/Trailing Arm Bush	1.6, 1.6 VVT-i, 1.8, 1.8 VVT-i, 2.0, 2.0 D-4D, 2.0 TD, 2.0 VVT-i	F8-8102			
<b>AVENSIS Liftback (_T22_)</b>				09/1997 → 02/2003	
Dust Cover Kit, shock absorber	1.6, 1.6 VVT-i, 1.8, 1.8 VVT-i, 2.0, 2.0 D-4D, 2.0 TD, 2.0 VVT-i	AK-735087			
Dust Cover Kit, shock absorber	1.6, 1.6 VVT-i, 1.8, 1.8 VVT-i, 2.0, 2.0 D-4D, 2.0 TD, 2.0 VVT-i	AK-735111			





**Article Description****Article Nr.****Fitting Position****AVENSIS Liftback (\_T22\_) 09/1997 → 02/2003**

Belt Pulley, crankshaft	1.8 VVT-i	Number of Ribs: 6	<b>F8-6388</b>		d=25; D=135.1
Belt Pulley, crankshaft	1.8	Number of Ribs: 5	<b>F8-6389</b>		d=25; D=137.2
Control Arm-/Trailing Arm Bush	1.6 , 1.6 VVT-i, 1.8 , 1.8 VVT-i, 2.0 , 2.0 D-4D , 2.0 TD , 2.0 VVT-i		<b>F8-8102</b>		H=54; d=18; W=60

**AVENSIS Station Wagon (\_T22\_) 09/1997 → 02/2003**

Dust Cover Kit, shock absorber	1.6 , 1.6 VVT-i, 1.8 , 1.8 VVT-i, 2.0 , 2.0 D-4D , 2.0 TD , 2.0 VVT-i		<b>AK-735087</b>		
Dust Cover Kit, shock absorber	1.6 , 1.6 VVT-i, 1.8 , 1.8 VVT-i, 2.0 , 2.0 D-4D , 2.0 TD , 2.0 VVT-i		<b>AK-735111</b>		
Belt Pulley, crankshaft	1.8 VVT-i	Number of Ribs: 6	<b>F8-6388</b>		d=25; D=135.1
Belt Pulley, crankshaft	1.8	Number of Ribs: 5	<b>F8-6389</b>		d=25; D=137.2
Control Arm-/Trailing Arm Bush	1.6 , 1.6 VVT-i, 1.8 , 1.8 VVT-i, 2.0 , 2.0 D-4D , 2.0 TD , 2.0 VVT-i		<b>F8-8102</b>		H=54; d=18; W=60

**AVENSIS (T25\_) 04/2003 → 11/2008**

Dust Cover Kit, shock absorber	1.6 VVT-i, 1.8, 2.0, 2.0 D-4D, 2.2 D-4D, 2.2 D-CAT, 2.4		<b>AK-735301</b>		
Dust Cover Kit, shock absorber	1.6 VVT-i, 1.8, 2.0, 2.0 D-4D, 2.2 D-4D, 2.2 D-CAT, 2.4		<b>AK-735302</b>		
Alternator Freewheel Clutch	2.0 D-4D		<b>F5-1030</b>		
Alternator Freewheel Clutch	2.0 D-4D, 2.2 D-4D, 2.2 D-CAT		<b>F5-1084</b>		
Alternator Freewheel Clutch	2.0 D-4D, 2.2 D-4D, 2.2 D-CAT		<b>F5-1152</b>		
Belt Pulley, crankshaft	1.8	Number of Ribs: 6	<b>F8-6388</b>		d=25; D=135.1
Rubber Buffer, suspension	1.6 VVT-i, 1.8, 2.0, 2.0 D-4D, 2.2 D-4D, 2.2 D-CAT, 2.4	<b>ST</b>	<b>F8-7677</b>		H=96
Belt Pulley, crankshaft	2.0 D-4D, 2.2 D-4D, 2.2 D-CAT		<b>F8-7868</b>		

**AVENSIS Estate (T25) 04/2003 → 11/2008**

Dust Cover Kit, shock absorber	1.6 VVT-i, 1.8, 2.0, 2.0 D-4D, 2.2 D-4D, 2.2 D-CAT, 2.4		<b>AK-735301</b>		
Dust Cover Kit, shock absorber	1.6 VVT-i, 1.8, 2.0, 2.0 D-4D, 2.2 D-4D, 2.2 D-CAT, 2.4		<b>AK-735302</b>		
Alternator Freewheel Clutch	2.0 D-4D		<b>F5-1030</b>		
Alternator Freewheel Clutch	2.0 D-4D, 2.2 D-4D, 2.2 D-CAT		<b>F5-1084</b>		
Alternator Freewheel Clutch	2.0 D-4D, 2.2 D-4D, 2.2 D-CAT		<b>F5-1152</b>		
Belt Pulley, crankshaft	1.8	Number of Ribs: 6	<b>F8-6388</b>		d=25; D=135.1
Rubber Buffer, suspension	1.6 VVT-i, 1.8, 2.0, 2.0 D-4D, 2.0 VVTi, 2.2 D-4D, 2.2 D-CAT, 2.4	<b>ST</b>	<b>F8-7677</b>		H=96
Belt Pulley, crankshaft	2.0 D-4D, 2.2 D-4D, 2.2 D-CAT		<b>F8-7868</b>		

**AVENSIS Saloon (T25) 04/2003 → 11/2008**

Dust Cover Kit, shock absorber	1.6 VVT-i, 1.8, 2.0, 2.0 D-4D, 2.2 D-4D, 2.2 D-CAT, 2.4		<b>AK-735301</b>		
Dust Cover Kit, shock absorber	1.6 VVT-i, 1.8, 2.0, 2.0 D-4D, 2.2 D-4D, 2.2 D-CAT, 2.4		<b>AK-735302</b>		
Alternator Freewheel Clutch	2.0 D-4D		<b>F5-1030</b>		
Alternator Freewheel Clutch	2.0 D-4D, 2.2 D-4D, 2.2 D-CAT		<b>F5-1084</b>		

<b>AK-735087</b>	<b>AK-735111</b>	<b>AK-735301</b>	<b>AK-735302</b>	<b>F5-1030</b>	<b>F5-1084</b>	<b>F5-1152</b>
Ref.Nr.:	Ref.Nr.:	Ref.Nr.: 4815702060	Ref.Nr.: 4825705010	Ref.Nr.: 27415-27011	Ref.Nr.: 2706030080	Ref.Nr.: 27415-26010
<b>F8-6388</b>	<b>F8-6389</b>	<b>F8-7677</b>	<b>F8-7868</b>			
Ref.Nr.: 13470-22021	Ref.Nr.: 13470-15120	Ref.Nr.: 48331-02050	Ref.Nr.: 13408-0R011	Ref.Nr.: 4806105010		

Article Description



Article Nr.

Fitting Position



<b>AVENSIS Saloon (T25)</b>			<b>04/2003 → 11/2008</b>		
Alternator Freewheel Clutch	2.0 D-4D, 2.2 D-4D, 2.2 D-CAT		<b>F5-1152</b>		
Belt Pulley, crankshaft	1.8	Number of Ribs: 6	<b>F8-6388</b>		d=25; D=135.1
Rubber Buffer, suspension	1.6 VVT-i, 1.8, 2.0, 2.0 D-4D, 2.0 VVTi, 2.2 D-4D, 2.2 D-CAT, 2.4	<b>ST</b>	<b>F8-7677</b>		H=96
Belt Pulley, crankshaft	2.0 D-4D, 2.2 D-4D, 2.2 D-CAT		<b>F8-7868</b>		
<b>AVENSIS Estate (ZRT27, ADT27)</b>			<b>02/2009 →</b>		
Alternator Freewheel Clutch	2.0 D-4D, 2.2 D-4D		<b>F5-1084</b>		
Alternator Freewheel Clutch	2.0 D-4D, 2.2 D-4D		<b>F5-1152</b>		
<b>AVENSIS Saloon (ZRT27, ADT27)</b>			<b>11/2008 →</b>		
Alternator Freewheel Clutch	2.0 D-4D, 2.2 D-4D		<b>F5-1084</b>		
Alternator Freewheel Clutch	2.0 D-4D, 2.2 D-4D		<b>F5-1152</b>		
<b>AVENSIS VERSO (_CLM2_, _ACM2_)</b>			<b>08/2001 → 11/2009</b>		
Dust Cover Kit, shock absorber	2.0 D-4D, 2.0 VVT-i, 2.4 VVTi GLS		<b>AK-735299</b>		
Dust Cover Kit, shock absorber	2.0 D-4D, 2.0 VVT-i, 2.4 VVTi GLS		<b>AK-735300</b>		
Alternator Freewheel Clutch	2.0 D-4D		<b>F5-1030</b>		
<b>AYGO (WNB1_, KGB1_)</b>			<b>07/2005 → 08/2010</b>		
Dust Cover Kit, shock absorber	1.0, 1.4 HDi		<b>AK-735285</b>		
Dust Cover Kit, shock absorber	1.0, 1.4 HDi		<b>AK-735286</b>		
Anti-Friction Bearing	1.0, 1.4 HDi		<b>F8-6266</b>		
Control Arm-/Trailing Arm Bush	1.0, 1.4 HDi		<b>F8-6587</b>		
Top Strut Mounting	1.0, 1.4 HDi		<b>F8-7170</b>		
Top Strut Mounting	1.0, 1.4 HDi		<b>F8-7171</b>		
<b>CAMRY (_CV1_, _XV1_, _V1_)</b>			<b>06/1991 → 09/1997</b>		
Control Arm-/Trailing Arm Bush	2.2, 3.0		<b>F8-5287</b>		H=62.6; d=14.3; D=60.3
Stabiliser Mounting	2.2, 3.0		<b>F8-8060</b>		
Stabiliser Mounting	All Models		<b>F8-8061</b>		
Control Arm-/Trailing Arm Bush	2.2		<b>F8-8103</b>		d=12.5; L=55; D=44
<b>CAMRY Station Wagon (_XV1_, _CV1_, _V10)</b>			<b>06/1991 → 07/1996</b>		
Control Arm-/Trailing Arm Bush	2.2, 3.0		<b>F8-5287</b>		H=62.6; d=14.3; D=60.3
Stabiliser Mounting	2.2, 3.0		<b>F8-8060</b>		
Stabiliser Mounting	All Models		<b>F8-8061</b>		
Control Arm-/Trailing Arm Bush	2.2		<b>F8-8103</b>		d=12.5; L=55; D=44

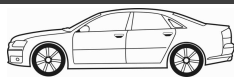

**Article Description****Article Nr.****Fitting Position**

<b>CAMRY (_CV2_, _XV2_) 08/1996 → 11/2001</b>			
Control Arm-/Trailing Arm Bush	2.2, 3.0 24V, 3.0 V6	F8-5287	H=62.6; d=14.3; D=60.3
Top Strut Mounting	2.2, 3.0 24V, 3.0 V6	F8-7366	
Top Strut Mounting	2.2, 3.0 24V, 3.0 V6	F8-7367	
Control Arm-/Trailing Arm Bush	2.2, 3.0 24V, 3.0 V6	F8-8041	
Stabiliser Mounting	2.2, 3.0 24V, 3.0 V6	F8-8062	
Stabiliser Mounting	2.2, 3.0 24V, 3.0 V6	F8-8063	
Control Arm-/Trailing Arm Bush	2.2	F8-8103	d=12.5; L=55; D=44
<b>CAMRY (MCV3_, ACV3_, XV3_) 11/2001 → 11/2006</b>			
Alternator Freewheel Clutch	2.4 VVT-i	F5-1073	
Alternator Freewheel Clutch	3.5 VVTi XLE	F5-1074	
Control Arm-/Trailing Arm Bush	2.4 VVT-i, 3.0 V6	F8-8048	
Stabiliser Mounting	2.4 VVT-i	F8-8056	
Stabiliser Mounting	2.4 VVT-i, 3.0 V6	F8-8057	
<b>CAMRY Saloon (_XV4_) 01/2006 → 09/2011</b>			
Alternator Freewheel Clutch	2.4 VVTi	F5-1073	
Alternator Freewheel Clutch	3.5	F5-1074	
<b>CAMRY Saloon (AVV5_, XV5_) 09/2011 →</b>			
Alternator Freewheel Clutch	2.0	F5-1073	
Alternator Freewheel Clutch	3.5	F5-1074	
<b>CAMRY SOLARA Convertible (MCV3_, ACV3_) 02/2004 → 11/2008</b>			
Alternator Freewheel Clutch	2.4	F5-1073	
Stabiliser Mounting	2.4	F8-8056	
<b>CAMRY SOLARA Coupe (MCV3_, ACV3_) 07/2003 → 07/2008</b>			
Stabiliser Mounting	2.4	F8-8056	
<b>CARINA Mk II (_T15_) 10/1983 → 05/1988</b>			
Dust Cover Kit, shock absorber	All Models	AK-735087	
<b>CARINA Mk II Saloon (_T15_) 10/1983 → 05/1988</b>			
Dust Cover Kit, shock absorber	1.6, 1.8 GLI, 2.0 D	AK-735087	
<b>CARINA Mk II (_T17_) 12/1987 → 06/1992</b>			
Dust Cover Kit, shock absorber	1.6, 2.0 D, 2.0 GLi	AK-735087	
Stabiliser Mounting	1.6, 2.0 D, 2.0 GLI	F8-8104	d=18

<b>AK-735087</b>	<b>F5-1073</b>	<b>F5-1074</b>	<b>F8-5287</b>	<b>F8-7366</b>	<b>F8-7367</b>	<b>F8-8041</b>
Ref.Nr.:	Ref.Nr.: 27415-0W040	Ref.Nr.: 27415-0W130	Ref.Nr.: 48655-07010	Ref.Nr.: 48603-33021	Ref.Nr.: 48609-06061	Ref.Nr.: 48655-06030
<b>F8-8048</b>	<b>F8-8056</b>	<b>F8-8057</b>	<b>F8-8062</b>	<b>F8-8063</b>	<b>F8-8103</b>	<b>F8-8104</b>
Ref.Nr.: 48069-06080	Ref.Nr.: 48815-33090	Ref.Nr.: 48818-21030	Ref.Nr.: 48815-33040	Ref.Nr.: 48818-06100	Ref.Nr.: 4872503010	Ref.Nr.: 48815-30060

Article Description



Article Nr.

Fitting Position



Article Description		Article Nr.	Fitting Position	12/1987 → 04/1992
<b>CARINA Mk II Estate (_T17_)</b>				
Dust Cover Kit, shock absorber	1.5 DX, 1.5 GL, 1.6, 1.6 GX 4x4, 1.8 G 4x4, 2.0, 2.0 D, 2.0 GLi	AK-735087		
Stabiliser Mounting	1.6, 2.0, 2.0 D, 2.0 GLi	F8-8104		d=18
Stabiliser Mounting	1.6, 2.0, 2.0 D, 2.0 GLi	F8-8104		d=18
<b>CARINA Mk II Saloon (_T17_)</b>				
12/1987 → 06/1992				
Dust Cover Kit, shock absorber	1.5, 1.6, 1.6 4x4, 1.8 4x4, 2.0, 2.0 D, 2.0 GLi	AK-735087		
Stabiliser Mounting	1.6, 2.0, 2.0 D, 2.0 GLi	F8-8104		d=18
<b>CARINA E (_T19_)</b>				
04/1992 → 09/1997				
Dust Cover Kit, shock absorber	All Models	AK-735087		
Control Arm-/Trailing Arm Bush	1.6, 1.6 16V, 1.6 GLi, 1.8, 2.0 D, 2.0 GLi, 2.0 GTi, 2.0 GTi 16V, 2.0 i, 2.0 TD	F8-5286		
Stabiliser Mounting	1.6, 1.6 16V, 1.6 GLi, 1.8, 2.0 D, 2.0 GLi, 2.0 GTi, 2.0 GTi 16V, 2.0 i, 2.0 TD	F8-8000		
<b>CARINA E Sportswagon (_T19_)</b>				
01/1993 → 09/1997				
Dust Cover Kit, shock absorber	1.6 GLi, 1.6 i, 1.8 GL, 1.8 i, 2.0 D, 2.0 GLi, 2.0 i, 2.0 TD	AK-735087		
Control Arm-/Trailing Arm Bush	1.6 GLi, 1.6 i, 1.8 i, 2.0 D, 2.0 GLi, 2.0 i, 2.0 TD	F8-5286		
<b>CARINA E Saloon (_T19_)</b>				
04/1992 → 09/1997				
Dust Cover Kit, shock absorber	All Models	AK-735087		
Control Arm-/Trailing Arm Bush	1.6, 1.6 16V, 1.8 i 16V, 2.0, 2.0 D, 2.0 GTi, 2.0 GTi 16V, 2.0 i, 2.0 TD	F8-5286		
Stabiliser Mounting	1.6, 1.6 16V, 1.8 i 16V, 2.0, 2.0 D, 2.0 GTi, 2.0 GTi 16V, 2.0 i, 2.0 TD	F8-8000		
<b>CELICA (ZZT23_)</b>				
08/1999 → 09/2005				
Belt Pulley, crankshaft	1.8 16V VT-i	F8-6388		d=25; D=135.1
Top Strut Mounting	All Models	F8-7472		
<b>COASTER Bus (TRB5_, XZB5_, RZB4_, HZB5_, BZB5_, BB4_)</b>				
08/2004 →				
Alternator Freewheel Clutch	2.7	F5-1074		
<b>COROLLA (_E7_)</b>				
09/1979 → 06/1983				
Control Arm-/Trailing Arm Bush	1.3	F8-8043		
<b>COROLLA (_E9_)</b>				
07/1987 → 06/1993				
Control Arm-/Trailing Arm Bush	1.3 i, 1.6, 1.6 i, 1.6 i 4WD, 1.8 D	F8-5286		
Top Strut Mounting	1.3 i, 1.6, 1.6 i, 1.8 D	F8-7361		
Top Strut Mounting	1.3 i, 1.6, 1.6 i, 1.8 D	F8-7362		

<b>AK-735087</b>	<b>F5-1074</b>	<b>F8-5286</b>	<b>F8-6388</b>	<b>F8-7361</b>	<b>F8-7362</b>	<b>F8-7472</b>
Ref.Nr.:	Ref.Nr.: 27415-0W130	Ref.Nr.: 4865420170	Ref.Nr.: 13470-22021	Ref.Nr.: 48071-12080	Ref.Nr.: 48072-12080	Ref.Nr.: 48609-20471
<b>F8-8000</b>	<b>F8-8043</b>	<b>F8-8104</b>				
Ref.Nr.: 48818-20280	Ref.Nr.: 48654-12010	Ref.Nr.: 48815-30060				

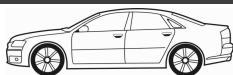
**Article Description****Article Nr.****Fitting Position**

<b>COROLLA (_E9_)</b>		<b>07/1987 → 06/1993</b>	
Control Arm-/Trailing Arm Bush	1.6, 1.6 i	<b>F8-8043</b>	
<b>COROLLA Compact (_E9_)</b>		<b>08/1987 → 04/1992</b>	
Control Arm-/Trailing Arm Bush	1.3, 1.6, 1.6 GTi, 1.6 i, 1.8 D	<b>F8-5286</b>	
Top Strut Mounting	1.3, 1.6, 1.6 GTi, 1.6 i, 1.8 D	<b>F8-7361</b>	
Top Strut Mounting	1.3, 1.6, 1.6 GTi, 1.6 i, 1.8 D	<b>F8-7362</b>	
<b>COROLLA Liftback (_E9_)</b>		<b>07/1987 → 06/1993</b>	
Control Arm-/Trailing Arm Bush	1.3 i, 1.6, 1.6 GTi, 1.8 D	<b>F8-5286</b>	
Top Strut Mounting	1.3 i, 1.6, 1.6 GTi, 1.8 D	<b>F8-7361</b>	
Top Strut Mounting	1.3 i, 1.6, 1.6 GTi, 1.8 D	<b>F8-7362</b>	
<b>COROLLA Station Wagon (_E9_)</b>		<b>12/1987 → 06/1992</b>	
Control Arm-/Trailing Arm Bush	1.3, 1.3 i, 1.6, 1.6 XLI, 1.6 XLI 4x4, 1.8 D	<b>F8-5286</b>	
Top Strut Mounting	1.3, 1.3 i, 1.6, 1.6 XLI, 1.6 XLI 4x4, 1.8 D	<b>F8-7361</b>	
Top Strut Mounting	1.3, 1.3 i, 1.6, 1.6 XLI, 1.6 XLI 4x4, 1.8 D	<b>F8-7362</b>	
Control Arm-/Trailing Arm Bush	1.6, 1.8 D	<b>F8-8043</b>	
<b>COROLLA (_E10_)</b>		<b>05/1992 → 04/1997</b>	
Control Arm-/Trailing Arm Bush	1.3 12V, 1.3 XLI, 1.3 XLI 16V, 1.6 Si, 2.0 D	<b>F8-5286</b>	
Top Strut Mounting	1.3 12V	<b>F8-6369</b>	
Top Strut Mounting	1.3 12V, 1.3 XLI, 1.3 XLI 16V, 1.6 Si, 2.0 D	<b>F8-7361</b>	
Top Strut Mounting	1.3 12V, 1.3 XLI, 1.3 XLI 16V, 1.6 Si, 2.0 D	<b>F8-7362</b>	
Stabiliser Mounting	1.3 12V, 1.3 XLI, 1.3 XLI 16V, 1.6 Si, 2.0 D	<b>F8-8000</b>	
Control Arm-/Trailing Arm Bush	1.3 12V, 1.3 XLI, 1.3 XLI 16V, 1.6 Si, 2.0 D	<b>F8-8042</b>	
Control Arm-/Trailing Arm Bush	1.3 12V, 1.3 XLI, 1.3 XLI 16V, 1.6, 1.6 Si, 1.8 i, 2.0 D	<b>F8-8044</b>	
Control Arm-/Trailing Arm Bush	1.3 12V, 1.3 XLI, 1.3 XLI 16V, 1.6 Si, 2.0 D	<b>F8-8065</b>	
<b>COROLLA Compact (_E10_)</b>		<b>07/1992 → 04/1997</b>	
Control Arm-/Trailing Arm Bush	1.3 12V, 1.3 XLI, 1.3 XLI 16V, 1.6 Si, 1.8 GT, 2.0 D	<b>F8-5286</b>	
Top Strut Mounting	1.3 12V	<b>F8-6369</b>	
Top Strut Mounting	1.3 12V, 1.3 XLI, 1.3 XLI 16V, 1.6 Si, 2.0 D	<b>F8-7361</b>	
Top Strut Mounting	1.3 12V, 1.3 XLI, 1.3 XLI 16V, 1.6 Si, 2.0 D	<b>F8-7362</b>	

<b>F8-5286</b>	<b>F8-6369</b>	<b>F8-7361</b>	<b>F8-7362</b>	<b>F8-8000</b>	<b>F8-8042</b>	<b>F8-8043</b>
Ref.Nr.: 4865420170	Ref.Nr.: 4860912270	Ref.Nr.: 48071-12080	Ref.Nr.: 48072-12080	Ref.Nr.: 48818-20280	Ref.Nr.: 48654-12050	Ref.Nr.: 48654-12010
<b>F8-8044</b>	<b>F8-8065</b>					
Ref.Nr.: 48655-12050	Ref.Nr.: 48655-12120					

Article Description

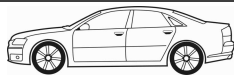

Article Nr.

Fitting Position



<b>COROLLA Compact (_E10_)</b>		<b>07/1992 → 04/1997</b>	
Stabiliser Mounting	1.3 12V, 1.3 XLI, 1.3 XLI 16V, 1.6 Si, 1.8 GT, 2.0 D	<b>F8-8000</b>	
Control Arm-/Trailing Arm Bush	1.3 12V, 1.3 XLI, 1.3 XLI 16V, 1.6 Si, 1.8 GT, 2.0 D	<b>F8-8042</b>	
Control Arm-/Trailing Arm Bush	1.3 12V, 1.3 XLI, 1.3 XLI 16V, 1.6 Si, 1.8 GT, 1.8 GTi 4x4, 2.0 D	<b>F8-8044</b>	
Control Arm-/Trailing Arm Bush	1.3 12V, 1.3 XLI, 1.3 XLI 16V, 1.6 Si, 1.8 GT, 2.0 D	<b>F8-8065</b>	
<b>COROLLA Liftback (_E10_)</b>		<b>05/1992 → 04/1997</b>	
Control Arm-/Trailing Arm Bush	1.3 12V, 1.3 XLI, 1.6 GLI, 1.8 GT, 2.0 D	<b>F8-5286</b>	
Top Strut Mounting	1.3 12V	<b>F8-6369</b>	
Top Strut Mounting	1.3 12V, 1.3 XLI, 1.6 GLI, 2.0 D	<b>F8-7361</b>	
Top Strut Mounting	1.3 12V, 1.3 XLI, 1.6 GLI, 2.0 D	<b>F8-7362</b>	
Stabiliser Mounting	1.3 12V, 1.3 XLI, 1.6 GLI, 1.8 GT, 2.0 D	<b>F8-8000</b>	
Control Arm-/Trailing Arm Bush	1.3 12V, 1.3 XLI, 1.6 GLI, 1.8 GT, 2.0 D	<b>F8-8042</b>	
Control Arm-/Trailing Arm Bush	All Models	<b>F8-8044</b>	
Control Arm-/Trailing Arm Bush	1.3 12V, 1.3 XLI, 1.6 GLI, 1.8 GT, 2.0 D	<b>F8-8065</b>	
<b>COROLLA Wagon (_E10_)</b>		<b>07/1992 → 04/1997</b>	
Control Arm-/Trailing Arm Bush	1.3 12V, 1.3 XLI, 1.3 XLI 16V, 1.6 Si, 1.8 16V 4WD, 2.0 D	<b>F8-5286</b>	
Top Strut Mounting	1.3 12V	<b>F8-6369</b>	
Top Strut Mounting	1.3 12V, 1.3 XLI, 1.3 XLI 16V, 1.6 Si, 1.8 16V 4WD, 2.0 D	<b>F8-7361</b>	
Top Strut Mounting	1.3 12V, 1.3 XLI, 1.3 XLI 16V, 1.6 Si, 1.8 16V 4WD, 2.0 D	<b>F8-7362</b>	
Control Arm-/Trailing Arm Bush	1.3 12V, 1.3 XLI, 1.3 XLI 16V, 1.6 Si, 1.8 16V 4WD, 1.8 XL, 1.8 XL 4x4, 2.0 D	<b>F8-8042</b>	
Control Arm-/Trailing Arm Bush	All Models	<b>F8-8044</b>	
Control Arm-/Trailing Arm Bush	1.3 12V, 1.3 XLI, 1.3 XLI 16V, 1.6 Si, 1.8 16V 4WD, 1.8 XL, 1.8 XL 4x4, 2.0 D	<b>F8-8065</b>	
<b>COROLLA (_E11_)</b>		<b>04/1997 → 11/2001</b>	
Top Strut Mounting	1.4, 1.4 16V, 1.6, 1.6 16V, 1.6 Aut., 2.0 D, 2.0 D-4D	<b>F8-6369</b>	
Belt Pulley, crankshaft	1.6, 1.6 Aut.	<b>F8-6389</b>	d=25; D=137.2
Top Strut Mounting	1.4, 1.4 16V, 1.6, 1.6 16V, 1.6 Aut., 1.9 D, 2.0 D, 2.0 D-4D	<b>F8-7361</b>	
Top Strut Mounting	1.4, 1.4 16V, 1.6, 1.6 16V, 1.6 Aut., 1.9 D, 2.0 D, 2.0 D-4D	<b>F8-7362</b>	

<b>F8-5286</b>	<b>F8-6369</b>	<b>F8-6389</b>	<b>F8-7361</b>	<b>F8-7362</b>	<b>F8-8000</b>	<b>F8-8042</b>
Ref.Nr.: 4865420170	Ref.Nr.: 4860912270	Ref.Nr.: 13470-15120	Ref.Nr.: 48071-12080	Ref.Nr.: 48072-12080	Ref.Nr.: 48818-20280	Ref.Nr.: 48654-12050
	<b>F8-8044</b>					
	Ref.Nr.: 48655-12050					
	<b>F8-8065</b>					
	Ref.Nr.: 48655-12120					

**Article Description****Article Nr.****Fitting Position**

<b>COROLLA ( _E11_ )</b>		<b>04/1997 → 11/2001</b>	
Control Arm-/Trailing Arm Bush	1.4, 1.4 16V, 1.5, 1.6 16V, 1.6 Aut., 1.8 Linea Terra, 1.9 D, 2.0 D, 2.0 D-4D, 2.2 TD	<b>F8-8042</b>	
Control Arm-/Trailing Arm Bush	1.4, 1.4 16V, 1.6 16V, 1.6 Aut., 1.9 D, 2.0 D, 2.0 D-4D	<b>F8-8047</b>	⊕ ⊕
Control Arm-/Trailing Arm Bush	1.4, 1.4 16V, 1.5, 1.6 16V, 1.6 Aut., 1.8 Linea Terra, 1.9 D, 2.0 D, 2.0 D-4D, 2.2 TD	<b>F8-8065</b>	
<b>COROLLA Compact ( _E11_ )</b>		<b>04/1997 → 01/2002</b>	
Top Strut Mounting	1.4, 1.6, 1.6 Aut., 2.0 D, 2.0 D-4D	<b>F8-6369</b>	
Belt Pulley, crankshaft	1.6, 1.6 Aut.	<b>F8-6389</b>	Number of Ribs: 5 d=25; D=137.2
Top Strut Mounting	1.4, 1.6, 1.6 Aut., 1.9 D, 2.0 D, 2.0 D-4D	<b>F8-7361</b>	⊕
Top Strut Mounting	1.4, 1.6, 1.6 Aut., 1.9 D, 2.0 D, 2.0 D-4D	<b>F8-7362</b>	⊕
Control Arm-/Trailing Arm Bush	All Models	<b>F8-8042</b>	
Control Arm-/Trailing Arm Bush	1.4, 1.6, 1.6 Aut., 1.9 D, 2.0 D, 2.0 D-4D	<b>F8-8047</b>	⊕ ⊕
Control Arm-/Trailing Arm Bush	All Models	<b>F8-8065</b>	
<b>COROLLA Liftback ( _E11_ )</b>		<b>04/1997 → 01/2002</b>	
Top Strut Mounting	1.4, 1.6, 1.6 Aut., 2.0 D, 2.0 D-4D	<b>F8-6369</b>	
Belt Pulley, crankshaft	1.6, 1.6 Aut.	<b>F8-6389</b>	Number of Ribs: 5 d=25; D=137.2
Top Strut Mounting	1.4, 1.6, 1.6 Aut., 1.9 D, 2.0 D, 2.0 D-4D	<b>F8-7361</b>	⊕
Top Strut Mounting	1.4, 1.6, 1.6 Aut., 1.9 D, 2.0 D, 2.0 D-4D	<b>F8-7362</b>	⊕
Rubber Buffer, suspension	2.0 D-4D	<b>F8-7677</b>	⊕ ⊕ ⊕ H=96
Rubber Buffer, suspension	2.0 D-4D	<b>F8-7678</b>	⊕ ⊕ ⊕
Control Arm-/Trailing Arm Bush	1.4, 1.6, 1.6 Aut., 1.9 D, 2.0 D, 2.0 D-4D	<b>F8-8042</b>	
Control Arm-/Trailing Arm Bush	1.4, 1.6, 1.6 Aut., 1.9 D, 2.0 D, 2.0 D-4D	<b>F8-8065</b>	
<b>COROLLA Wagon ( _E11_ )</b>		<b>04/1997 → 10/2001</b>	
Top Strut Mounting	1.4, 1.4 16V, 1.6, 1.6 16V, 1.6 Aut., 2.0 D, 2.0 D-4D	<b>F8-6369</b>	
Belt Pulley, crankshaft	1.6, 1.6 Aut.	<b>F8-6389</b>	Number of Ribs: 5 d=25; D=137.2
Top Strut Mounting	1.4, 1.4 16V, 1.6, 1.6 16V, 1.6 Aut., 1.8 AWD, 1.9 D, 2.0 D, 2.0 D-4D	<b>F8-7361</b>	⊕
Top Strut Mounting	1.4, 1.4 16V, 1.6, 1.6 16V, 1.6 Aut., 1.8 AWD, 1.9 D, 2.0 D, 2.0 D-4D	<b>F8-7362</b>	⊕
Control Arm-/Trailing Arm Bush	1.4, 1.4 16V, 1.6, 1.6 16V, 1.6 Aut., 1.8 AWD, 1.9 D, 2.0 D, 2.0 D-4D, 2.0 D4d GS	<b>F8-8042</b>	
Control Arm-/Trailing Arm Bush	1.4, 1.4 16V, 1.6, 1.6 16V, 1.6 Aut., 1.8 AWD, 1.9 D, 2.0 D, 2.0 D-4D, 2.0 D4d GS	<b>F8-8065</b>	

<b>AK-735292</b>	<b>F8-6369</b>	<b>F8-6389</b>	<b>F8-7361</b>	<b>F8-7362</b>	<b>F8-7677</b>	<b>F8-7678</b>
Ref.Nr.: 4825732090	Ref.Nr.: 4860912270	Ref.Nr.: 13470-15120	Ref.Nr.: 48071-12080	Ref.Nr.: 48072-12080	Ref.Nr.: 48331-02050	Ref.Nr.: 48341-02040
<b>F8-8042</b>	<b>F8-8047</b>	<b>F8-8065</b>				
Ref.Nr.: 48654-12050	Ref.Nr.: 48655-12170	Ref.Nr.: 48655-12120				

Article Description



Article Nr.

Fitting Position



<b>COROLLA (CDE12_, ZZE12_, NDE12_, ZDE12_)</b>		12/2001 → 02/2007	
Dust Cover Kit, shock absorber	1.4 D, 1.4 VVT-i, 1.6 VVT-i, 1.8 VVTi, 1.8 VVTL-i TS, 2.0 D-4D	AK-735292	
Dust Cover Kit, shock absorber	1.4 D, 1.4 VVT-i, 1.6 VVT-i, 1.8 VVTL-i TS, 2.0 D-4D	AK-735301	
Alternator Freewheel Clutch	2.0 D-4D	F5-1030	
Top Strut Mounting	1.4 D, 1.4 VVT-i, 1.6 VVT-i, 1.8 All-wheel Drive, 1.8 VVTi, 1.8 VVTL-i TS, 2.0 D-4D	F8-7472	
Rubber Buffer, suspension	1.4 D, 1.4 VVT-i, 1.8 VVTi, 2.0 D-4D	F8-7677	H=96
Rubber Buffer, suspension	1.4 D, 1.4 VVT-i, 1.8 VVTi, 2.0 D-4D	F8-7678	
<b>COROLLA Estate (_E12J_, _E12T_)</b>		12/2001 → 02/2007	
Dust Cover Kit, shock absorber	1.4 D, 1.4 VVT-i, 1.6 VVT-i, 1.8, 2.0 D-4D	AK-735292	
Dust Cover Kit, shock absorber	1.4 D, 1.4 VVT-i, 1.6 VVT-i, 2.0 D-4D	AK-735301	
Alternator Freewheel Clutch	2.0 D-4D	F5-1030	
Top Strut Mounting	All Models	F8-7472	
Rubber Buffer, suspension	1.4 D, 1.4 VVT-i, 2.0 D-4D	F8-7677	H=96
Rubber Buffer, suspension	1.4 D, 1.4 VVT-i, 2.0 D-4D	F8-7678	
<b>COROLLA Saloon (_E12J_, _E12T_)</b>		03/2001 → 07/2007	
Dust Cover Kit, shock absorber	1.4 D, 1.4 VVT-i, 1.5, 1.6 VVT-i, 1.8, 2.0 D4d, 2.0 D-4D	AK-735292	
Dust Cover Kit, shock absorber	1.4 D, 1.4 VVT-i, 1.6 VVT-i, 2.0 D4d, 2.0 D-4D	AK-735301	
Alternator Freewheel Clutch	2.0 D4d, 2.0 D-4D	F5-1030	
Top Strut Mounting	1.4 D, 1.4 VVT-i, 1.5, 1.6, 1.6 VVT-i, 1.8, 1.8 4x4, 2.0 D4d, 2.0 D-4D	F8-7472	
Rubber Buffer, suspension	1.4 D, 1.4 VVT-i, 2.0 D4d, 2.0 D-4D	F8-7677	H=96
Rubber Buffer, suspension	1.4 D, 1.4 VVT-i, 2.0 D4d, 2.0 D-4D	F8-7678	
<b>COROLLA Verso (ZDE12_, CDE12_)</b>		09/2001 → 05/2004	
Dust Cover Kit, shock absorber	1.4 VVT-i, 1.6 VVT-i, 1.8 VVT-i, 2.0 D-4D	AK-735292	
Dust Cover Kit, shock absorber	1.6 VVT-i, 1.8 VVT-i	AK-735293	
Dust Cover Kit, shock absorber	1.4 VVT-i, 1.6 VVT-i, 1.8 VVT-i	AK-735295	
Dust Cover Kit, shock absorber	2.0 D-4D	AK-735296	
Alternator Freewheel Clutch	2.0 D-4D	F5-1030	
Belt Pulley, crankshaft	1.8 VVT-i	F8-6388	d=25; D=135.1
Top Strut Mounting	1.4 D4d, 1.4 VVT-i, 1.6 VVT-i, 1.8 VVT-i, 2.0 D4d, 2.0 D-4D	F8-7472	
Rubber Buffer, suspension	2.0 D-4D	F8-7677	H=96
Rubber Buffer, suspension	2.0 D-4D	F8-7678	
<b>COROLLA Verso (ZER_, ZZE12_, R1_)</b>		04/2004 → 03/2009	
Dust Cover Kit, shock absorber	1.6, 1.8, 2.0 D-4D, 2.2 D-4D	AK-735297	



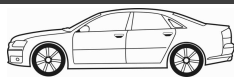

**Article Description****Article Nr.****Fitting Position**

<b>COROLLA Verso (ZER_, ZZE12_, R1_)</b>			<b>04/2004 → 03/2009</b>		
Dust Cover Kit, shock absorber	1.6, 1.8, 2.0 D-4D, 2.2 D-4D		<b>AK-735298</b>		
Alternator Freewheel Clutch	2.0 D-4D		<b>F5-1030</b>		
Alternator Freewheel Clutch	2.2 D-4D		<b>F5-1084</b>		
Alternator Freewheel Clutch	2.2 D-4D		<b>F5-1152</b>		
Belt Pulley, crankshaft	1.8	Number of Ribs: 6	<b>F8-6388</b>		d=25; D=135.1
Belt Pulley, crankshaft	2.2 D-4D		<b>F8-7868</b>		
<b>COROLLA Saloon (E15_)</b>			<b>11/2006 →</b>		
Alternator Freewheel Clutch	2.0 D-4D		<b>F5-1084</b>		
Alternator Freewheel Clutch	2.0 D-4D, 2.2 D-4D		<b>F5-1152</b>		
Top Strut Mounting	2.2 D-4D		<b>F8-7472</b>		
<b>CROWN Saloon (CRS_, JZS_, GRS18_, UZS_)</b>			<b>09/2004 → 02/2008</b>		
Alternator Freewheel Clutch	3.0		<b>F5-1074</b>		
<b>CROWN Saloon (GRS20_)</b>			<b>02/2008 → 11/2012</b>		
Alternator Freewheel Clutch	2.5 V6, 2.5 V6 4WD, 3.0, 3.0 4WD, 3.5 V6		<b>F5-1074</b>		
<b>DYNA Platform/Chassis (KD_, LY_, TRY2_, KDY2_, XZU4_, XZU3_)</b>			<b>08/2001 →</b>		
Alternator Freewheel Clutch	3.0 D4d		<b>F5-1084</b>		
Alternator Freewheel Clutch	2.5 D4d		<b>F5-1115</b>		
Alternator Freewheel Clutch	3.0 D4d, 3.0 D4d 4WD		<b>F5-1152</b>		
<b>ECHO Hatchback (NCP13_, NCP12_)</b>			<b>01/2000 → 03/2003</b>		
Alternator Freewheel Clutch	1.4 D4d		<b>F5-1133</b>		
<b>FORTUNER (TGN6_, KUN6_, GGN6_, TGN5_, LAN5_, KUN5_, GGN5_)</b>			<b>06/2004 → 05/2015</b>		
Alternator Freewheel Clutch	2.5 D-4D 4WD, 2.5 D-4D 4x4, 3.0 D, 3.0 D 4x4		<b>F5-1047</b>		
Alternator Freewheel Clutch	2.5 D-4D 4WD, 2.5 D-4D 4x4, 3.0 D, 3.0 D 4x4		<b>F5-1101</b>		
Alternator Freewheel Clutch	3.0 D, 3.0 D 4x4		<b>F5-1115</b>		
<b>HIACE II Box (LH5_, YH7_, LH7_, LH6_, YH6_, YH5_)</b>			<b>03/1983 → 11/1989</b>		
Control Arm-/Trailing Arm Bush	2.2 4x4, 2.2 D, 2.4 D		<b>F8-8110</b>		
Control Arm-/Trailing Arm Bush	2.2 4x4, 2.2 D, 2.4 D		<b>F8-8111</b>		
					H=74; d=26; D=56
<b>HIACE II Wagon (LH7_, LH5_, LH6_, YH7_, YH6_, YH5_)</b>			<b>03/1983 → 11/1989</b>		
Control Arm-/Trailing Arm Bush	2.0, 2.2 D, 2.4 D, 2.4 D 4WD		<b>F8-8110</b>		
Control Arm-/Trailing Arm Bush	2.0, 2.2 D, 2.4 D, 2.4 D 4WD		<b>F8-8111</b>		
					H=74; d=26; D=56

<b>AK-735298</b>	<b>F5-1030</b>	<b>F5-1047</b>	<b>F5-1074</b>	<b>F5-1084</b>	<b>F5-1101</b>	<b>F5-1115</b>
Ref.Nr.: 483410F010	Ref.Nr.: 27415-27011	Ref.Nr.: 274150L020	Ref.Nr.: 27415-0W130	Ref.Nr.: 2706030080	Ref.Nr.: 27415-0L020	Ref.Nr.: 27415-30020
<b>F5-1133</b>	<b>F5-1152</b>	<b>F8-6388</b>	<b>F8-7472</b>	<b>F8-7868</b>	<b>F8-8110</b>	<b>F8-8111</b>
Ref.Nr.: 27415-33020	Ref.Nr.: 27415-26010	Ref.Nr.: 13470-22021	Ref.Nr.: 48609-20471	Ref.Nr.: 13408-0R011	Ref.Nr.: 4863226010	Ref.Nr.: 4863526010

<b>Article Description</b>			<b>Article Nr.</b>	<b>Fitting Position</b>	
----------------------------	--	--	--------------------	-------------------------	--

<b>HIACE III Box (YH7_, LH6_, LH7_, LH5_, YH5_, YH6_)</b>			<b>08/1989 → 08/2004</b>		
Alternator Freewheel Clutch	2.5 D-4D 4x4		<b>F5-1115</b>		
Alternator Freewheel Clutch	2.5 D-4D 4x4		<b>F5-1152</b>		
Control Arm-/Trailing Arm Bush	2.0, 2.4 4WD, 2.4 D, 2.4 D 4WD, 2.4 D 4x4, 2.4 Diesel, 2.5 D-4D 4x4		<b>F8-8110</b>		
Control Arm-/Trailing Arm Bush	2.0, 2.4 4WD, 2.4 D, 2.4 D 4WD, 2.4 D 4x4, 2.4 Diesel, 2.5 D-4D 4x4		<b>F8-8111</b>		H=74; d=26; D=56
<b>HIACE III Wagon (LH1_, RZH1_)</b>			<b>08/1989 → 08/2004</b>		
Alternator Freewheel Clutch	2.5 D-4D 4x4		<b>F5-1115</b>		
Alternator Freewheel Clutch	2.5 D-4D 4x4		<b>F5-1152</b>		
Control Arm-/Trailing Arm Bush	2.4, 2.4 4WD, 2.4 D, 2.4 D 4WD, 2.5 D-4D 4x4		<b>F8-8110</b>		
Control Arm-/Trailing Arm Bush	2.4, 2.4 4WD, 2.4 D, 2.4 D 4WD, 2.5 D-4D 4x4		<b>F8-8111</b>		H=74; d=26; D=56
<b>HIACE IV Bus (LH1_)</b>			<b>08/1995 → 08/2006</b>		
Alternator Freewheel Clutch	2.5 D-4D		<b>F5-1080</b>		
Alternator Freewheel Clutch	2.5 D-4D		<b>F5-1115</b>		
Alternator Freewheel Clutch	2.5 D-4D, 2.5 D-4D 4x4		<b>F5-1152</b>		
Control Arm-/Trailing Arm Bush	2.4, 2.4 4WD, 2.4 D, 2.4 TD, 2.4 TD 4WD, 2.5 D-4D, 2.7, 2.7 4WD		<b>F8-8110</b>		
Control Arm-/Trailing Arm Bush	2.4, 2.4 4WD, 2.4 D, 2.4 TD, 2.4 TD 4WD, 2.5 D-4D, 2.7, 2.7 4WD		<b>F8-8111</b>		H=74; d=26; D=56
<b>HIACE IV Box (LXH1_, RZH1_, LH1_)</b>			<b>08/1995 → 08/2006</b>		
Alternator Freewheel Clutch	2.5 D-4D		<b>F5-1080</b>		
Alternator Freewheel Clutch	2.5 D-4D		<b>F5-1084</b>		
Alternator Freewheel Clutch	2.5 D-4D, 2.5 D-4D 4WD		<b>F5-1115</b>		
Alternator Freewheel Clutch	2.5 D-4D, 2.5 D-4D 4WD, 2.5 D-4D 4x4		<b>F5-1152</b>		
Control Arm-/Trailing Arm Bush	2.4, 2.4 4WD, 2.4 D, 2.4 TD, 2.4 TD 4WD, 2.5 D-4D, 2.5 D-4D 4WD, 2.7, 2.7 4WD		<b>F8-8110</b>		
Control Arm-/Trailing Arm Bush	2.4, 2.4 4WD, 2.4 D, 2.4 TD, 2.4 TD 4WD, 2.5 D-4D, 2.5 D-4D 4WD, 2.7, 2.7 4WD		<b>F8-8111</b>		H=74; d=26; D=56
<b>HIACE V Box (TRH2_, KDH2_)</b>			<b>01/2005 →</b>		
Alternator Freewheel Clutch	2.0, 2.7 VVTi		<b>F5-1074</b>		
Alternator Freewheel Clutch	2.5 D-4D, 3.0 D		<b>F5-1084</b>		
Alternator Freewheel Clutch	2.5 D-4D, 3.0 D		<b>F5-1152</b>		
<b>HIACE / COMMUTER V (TRH2_, KDH2_)</b>			<b>01/2005 →</b>		
Alternator Freewheel Clutch	2.0, 2.7 VVTi		<b>F5-1074</b>		
Alternator Freewheel Clutch	2.5 D-4D, 3.0 D		<b>F5-1084</b>		
Alternator Freewheel Clutch	2.5 D-4D, 2.5 D-4D 4WD, 3.0 D		<b>F5-1152</b>		

<b>F5-1074</b>	<b>F5-1080</b>	<b>F5-1084</b>	<b>F5-1115</b>	<b>F5-1152</b>	<b>F8-8110</b>	<b>F8-8111</b>
Ref.Nr.: 27415-0W130	Ref.Nr.: 2706000L20	Ref.Nr.: 2706030080	Ref.Nr.: 27415-30020	Ref.Nr.: 27415-26010	Ref.Nr.: 4863226010	Ref.Nr.: 4863526010

**Article Description****Article Nr.****Fitting Position**

<b>HILUX II Pickup (LN8_, RN5_, LN6_, YN6_, YN5_, LN5_, RN6_)</b>			<b>01/1984 → 07/2005</b>		
Alternator Freewheel Clutch	2.5 D-4D, 2.5 D-4D 4WD		<b>F5-1080</b>		
Alternator Freewheel Clutch	2.5 D-4D, 2.5 D-4D 4WD		<b>F5-1115</b>		
Control Arm-/Trailing Arm Bush	1.8 , 2.0, 2.4 D, 2.5 D-4D, 2.7, 3.0 D		<b>F8-8045</b>		
Control Arm-/Trailing Arm Bush	2.4 D		<b>F8-8046</b>		
Control Arm-/Trailing Arm Bush	2.4 D 4WD, 2.4 i 4WD, 2.4 TD 4WD, 2.5 D-4D 4WD, 3.0 D 4WD		<b>F8-8110</b>	⊕ ⊕	
Control Arm-/Trailing Arm Bush	2.4 D 4WD, 2.4 i 4WD, 2.4 TD 4WD, 2.5 D-4D 4WD, 3.0 D 4WD		<b>F8-8111</b>	⊕ ⊕ ↑	H=74; d=26; D=56
<b>HILUX (VIGO) III Pickup (KUN_, TGN_, LAN_, GGN_)</b>			<b>07/2005 → 09/2006</b>		
Alternator Freewheel Clutch	2.5 D 4x4, 2.5 D-4D, 2.5 D-4D 4x4, 3.0 , 3.0 All-wheel Drive, 3.0 D , 3.0 D-4D 4x4		<b>F5-1047</b>		
Alternator Freewheel Clutch	2.5 D 4x4, 2.5 D-4D		<b>F5-1080</b>		
Alternator Freewheel Clutch	2.5 D 4x4, 2.5 D-4D, 2.5 D-4D 4x4, 3.0 , 3.0 All-wheel Drive, 3.0 D , 3.0 D-4D 4x4		<b>F5-1101</b>		
Alternator Freewheel Clutch	2.5 D 4x4, 2.5 D-4D, 2.5 D-4D 4x4, 3.0 , 3.0 All-wheel Drive, 3.0 D , 3.0 D-4D 4x4		<b>F5-1115</b>		
<b>HILUX III Platform/Chassis (KUN1_, TGN3_, TGN2_, TGN1_, KUN2)</b>			<b>02/2005 →</b>		
Alternator Freewheel Clutch	3.0 D, 3.0 D 4x4		<b>F5-1047</b>		
Alternator Freewheel Clutch	3.0 D, 3.0 D 4x4		<b>F5-1101</b>		
<b>KIJANG INNOVA (_TGN4_, _KUN4_)</b>			<b>08/2004 →</b>		
Alternator Freewheel Clutch	2.5 D4d		<b>F5-1101</b>		
Alternator Freewheel Clutch	2.5 D4d		<b>F5-1115</b>		
<b>LAND CRUISER (_J6_)</b>			<b>08/1987 → 12/1989</b>		
Control Arm-/Trailing Arm Bush	4.0		<b>F8-8135</b>	⊕ ⊕	H=60; d=18; D=55
<b>LAND CRUISER Hardtop (_J7_)</b>			<b>07/1990 → 05/1996</b>		
Control Arm-/Trailing Arm Bush	2.4 TD		<b>F8-8055</b>		
<b>LAND CRUISER Pickup (_J7_)</b>			<b>03/2007 →</b>		
Alternator Freewheel Clutch	4.0 4x4		<b>F5-1074</b>		
<b>LAND CRUISER 80 (_J8_)</b>			<b>01/1990 → 12/1997</b>		
Control Arm-/Trailing Arm Bush	4.0 , 4.2 TD , 4.2 TD 24V		<b>F8-8135</b>	⊕ ⊕	H=60; d=18; D=55
<b>LAND CRUISER 90 (_J9_)</b>			<b>04/1995 → 07/2002</b>		
Alternator Freewheel Clutch	3.0 D-4D		<b>F5-1084</b>		
Alternator Freewheel Clutch	3.0 D-4D		<b>F5-1115</b>		

<b>F5-1047</b>	<b>F5-1074</b>	<b>F5-1080</b>	<b>F5-1084</b>	<b>F5-1101</b>	<b>F5-1115</b>	<b>F5-1152</b>
Ref.Nr.: 274150L020	Ref.Nr.: 27415-0W130	Ref.Nr.: 2706000L20	Ref.Nr.: 2706030080	Ref.Nr.: 27415-0L020	Ref.Nr.: 27415-30020	Ref.Nr.: 27415-26010
<b>F8-8045</b>	<b>F8-8046</b>	<b>F8-8055</b>	<b>F8-8110</b>	<b>F8-8111</b>	<b>F8-8135</b>	
Ref.Nr.: 48654-35010	Ref.Nr.: 48632-35020	Ref.Nr.: 48061-60040	Ref.Nr.: 4863226010	Ref.Nr.: 4863526010	Ref.Nr.: 48702-60040	

Article Description



Article Nr.

Fitting Position



<b>LAND CRUISER 90 (_J9_)</b>			<b>04/1995 → 07/2002</b>		
Alternator Freewheel Clutch	3.0 D-4D		<b>F5-1152</b>		
Stabiliser Mounting	2.7	01/1998 →;	<b>F8-8064</b>		
Stabiliser Mounting	3.0 D-4D , 3.0 TD		<b>F8-8064</b>		
Stabiliser Mounting	3.4 i 24V	01/1998 →	<b>F8-8064</b>		
<b>LAND CRUISER AMAZON (FZJ1_ , UZJ1_)</b>			<b>01/1998 → 08/2007</b>		
Control Arm-/Trailing Arm Bush	4.2 TD		<b>F8-8049</b>		
Control Arm-/Trailing Arm Bush	4.2 TD		<b>F8-8050</b>		
Control Arm-/Trailing Arm Bush	4.2 D 4x4 , 4.2 TD		<b>F8-8051</b>		
Control Arm-/Trailing Arm Bush	All Models		<b>F8-8052</b>		
Control Arm-/Trailing Arm Bush	All Models		<b>F8-8053</b>		
Control Arm-/Trailing Arm Bush	All Models		<b>F8-8054</b>		
<b>LAND CRUISER (LJ12_ , KZJ12_ , TRJ12_ , KDJ12_ , GRJ12_)</b>			<b>09/2002 → 07/2009</b>		
Alternator Freewheel Clutch	4.0		<b>F5-1074</b>		
Alternator Freewheel Clutch	3.0 D-4D		<b>F5-1080</b>		
Alternator Freewheel Clutch	3.0 D-4D		<b>F5-1115</b>		
Alternator Freewheel Clutch	3.0 D-4D		<b>F5-1152</b>		
<b>LAND CRUISER 150 (KDJ15_ , GRJ15_)</b>			<b>01/2010 →</b>		
Alternator Freewheel Clutch	2.7 4WD, 4.0 V6 Dual VVTi, 4.0 V6 VVTi, 4.0 V6 VVT-i		<b>F5-1074</b>		
Alternator Freewheel Clutch	3.0 D-4D		<b>F5-1084</b>		
Alternator Freewheel Clutch	3.0 D-4D		<b>F5-1152</b>		
<b>LAND CRUISER 200 (VDJ2_ , UZJ2_)</b>			<b>01/2010 →</b>		
Alternator Freewheel Clutch	4.0 VVTi		<b>F5-1074</b>		
<b>LITEACE Box (CM3_V , KM3_V)</b>			<b>10/1985 → 09/1991</b>		
Stabiliser Mounting	1.5 , 1.8 D		<b>F8-8104</b>		d=18
<b>MARK X II (GRX13_)</b>			<b>10/2009 →</b>		
Alternator Freewheel Clutch	2.5, 2.5 4WD		<b>F5-1074</b>		
<b>MASTER ACE SURF Bus</b>			<b>02/1985 → 08/1999</b>		
Stabiliser Mounting	2.0, 2.0 D, 2.0 TD		<b>F8-8104</b>		d=18
<b>MODELL F Bus (_R2_ , 31)</b>			<b>11/1982 → 08/1988</b>		
Stabiliser Mounting	1.8 4x4, 1.8 De Luxe , 2.0 Super		<b>F8-8104</b>		d=18

<b>F5-1074</b>	<b>F5-1080</b>	<b>F5-1084</b>	<b>F5-1115</b>	<b>F5-1152</b>	<b>F8-8049</b>	<b>F8-8050</b>
Ref.Nr.: 27415-0W130	Ref.Nr.: 2706000L20	Ref.Nr.: 2706030080	Ref.Nr.: 27415-30020	Ref.Nr.: 27415-26010	Ref.Nr.: 48702-60110	Ref.Nr.: 48702-60100
<b>F8-8051</b>	<b>F8-8052</b>	<b>F8-8053</b>	<b>F8-8054</b>	<b>F8-8064</b>	<b>F8-8104</b>	
Ref.Nr.: 48702-60090	Ref.Nr.: 48654-60010	Ref.Nr.: 48655-60010	Ref.Nr.: 48632-60010	Ref.Nr.: 48815-35100	Ref.Nr.: 48815-30060	

**Article Description****Article Nr.****Fitting Position**

<b>MR 2 III (ZZW3_)</b>				<b>10/1999 → 06/2007</b>	
Dust Cover Kit, shock absorber	All Models		<b>AK-735303</b>		
Dust Cover Kit, shock absorber	All Models		<b>AK-735304</b>		
Belt Pulley, crankshaft	All Models	Number of Ribs: 6	<b>F8-6388</b>		d=25; D=135.1
<b>PICNIC (_XM10)</b>				<b>05/1996 → 12/2001</b>	
Top Strut Mounting	2.0 16V , 2.2 D		<b>F8-7360</b>		
<b>PREVIA (MCR3_ , ACR3_ , CLR3_)</b>				<b>02/2000 → 01/2006</b>	
Alternator Freewheel Clutch	2.0 D-4D		<b>F5-1030</b>		
Alternator Freewheel Clutch	2.4 16V		<b>F5-1073</b>		
Alternator Freewheel Clutch	3.5, 3.5 4x4		<b>F5-1074</b>		
<b>PREVIA III (AHR5_ , GSR5_ , ACR5_)</b>				<b>10/2005 →</b>	
Alternator Freewheel Clutch	2.4		<b>F5-1073</b>		
Alternator Freewheel Clutch	3.5, 3.5 4WD		<b>F5-1074</b>		
<b>PRIUS Saloon (NHW11_)</b>				<b>05/2000 → 01/2004</b>	
Dust Cover Kit, shock absorber	All Models		<b>AK-735291</b>		
Dust Cover Kit, shock absorber	All Models		<b>AK-735292</b>		
<b>PRIUS Hatchback (NHW20_)</b>				<b>08/2003 → 03/2009</b>	
Dust Cover Kit, shock absorber	All Models		<b>AK-735292</b>		
Dust Cover Kit, shock absorber	All Models		<b>AK-735293</b>		
Dust Cover Kit, shock absorber	All Models		<b>AK-735295</b>		
<b>RAV 4 (SXA1_)</b>				<b>06/1994 → 06/2000</b>	
Top Strut Mounting	2.0 16V 4WD		<b>F8-7473</b>		
<b>RAV 4 (SXA1_)</b>				<b>12/1997 → 06/2000</b>	
Top Strut Mounting	All Models		<b>F8-7473</b>		
<b>RAV 4 Mk II (CLA2_ , XA2_ , ZCA2_ , ACA2_)</b>				<b>06/2000 → 11/2005</b>	
Dust Cover Kit, shock absorber	1.8 VVTi, 2.0 D-4D 4WD, 2.0 VVTi 4WD		<b>AK-735439</b>		
Alternator Freewheel Clutch	2.0 D-4D 4WD		<b>F5-1030</b>		
Belt Pulley, crankshaft	1.8 VVTi	Number of Ribs: 6	<b>F8-6388</b>		d=25; D=135.1
Top Strut Mounting	All Models		<b>F8-7473</b>		
<b>RAV 4 III (ACA3_ , ACE_ , ALA3_ , GSA3_ , ZSA3_)</b>				<b>11/2005 →</b>	
Dust Cover Kit, shock absorber	2.0 VVT-i 4WD, 2.2 D-4D 4WD, 2.2 D-CAT 4WD, 2.4 VVTi, 2.4 VVTi 4WD, 3.5 VVTi 4WD		<b>AK-735440</b>		
Alternator Freewheel Clutch	2.4 VVTi, 2.4 VVTi 4WD		<b>F5-1073</b>		
Alternator Freewheel Clutch	3.5 4WD		<b>F5-1074</b>		
Alternator Freewheel Clutch	2.2 D-4D, 2.2 D-4D 4WD, 2.2 D-CAT 4WD		<b>F5-1084</b>		

<b>AK-735291</b>	<b>AK-735292</b>	<b>AK-735293</b>	<b>AK-735295</b>	<b>AK-735303</b>	<b>AK-735304</b>	<b>AK-735439</b>
Ref.Nr.: 4815747010	Ref.Nr.: 4825732090	Ref.Nr.: 48331-12200	Ref.Nr.: 4833112200	Ref.Nr.: 4830417010	Ref.Nr.: 4833112130	Ref.Nr.: 4815742010
<b>AK-735440</b>	<b>F5-1030</b>	<b>F5-1073</b>	<b>F5-1074</b>	<b>F5-1084</b>	<b>F5-1152</b>	<b>F8-6388</b>
Ref.Nr.: 4815742020	Ref.Nr.: 27415-27011	Ref.Nr.: 27415-0W040	Ref.Nr.: 27415-0W130	Ref.Nr.: 2706030080	Ref.Nr.: 27415-26010	Ref.Nr.: 13470-22021
<b>F8-7360</b>	<b>F8-7473</b>					
Ref.Nr.: 48609-44020	Ref.Nr.: 48609-42010					

Article Description			Article Nr.	Fitting Position	
---------------------	--	--	-------------	------------------	--

<b>RAV 4 III (ACA3_, ACE_, ALA3_, GSA3_, ZSA3_)</b>			<b>11/2005 →</b>		
Alternator Freewheel Clutch	2.2 D-4D, 2.2 D-4D 4WD		<b>F5-1152</b>		
Belt Pulley, crankshaft	2.2 D-4D 4WD, 2.2 D-CAT 4WD		<b>F8-7868</b>		
<b>RAV 4 IV (WWA4_, AVA4_, ZSA4_, ALA4_)</b>			<b>12/2012 →</b>		
Alternator Freewheel Clutch	2.0 D4-D, 2.0 D4-D 4WD		<b>F5-1084</b>		
<b>REGIUSACE Bus (TRH2_, KDH2_)</b>			<b>08/2004 →</b>		
Alternator Freewheel Clutch	2.0, 2.7		<b>F5-1074</b>		
<b>REGIUSACE Box (TRH2_, KDH2_)</b>			<b>08/2004 →</b>		
Alternator Freewheel Clutch	2.0, 2.7		<b>F5-1074</b>		
<b>STARLET (_P7_)</b>			<b>10/1984 → 12/1989</b>		
Dust Cover Kit, shock absorber	1.0, 1.3, 1.5 D		<b>AK-735115</b>		
<b>URBAN CRUISER (NSP1_, NLP1_, ZSP1_, NCP11_)</b>			<b>04/2009 →</b>		
Anti-Friction Bearing	1.33, 1.4 D-4D, 1.4 D-4D 4WD		<b>F8-6266</b>		
<b>VERSO (_AUR2_, _ZGR2_)</b>			<b>04/2009 →</b>		
Alternator Freewheel Clutch	2.0 D-4D, 2.2 D-4D, 2.2 D-CAT		<b>F5-1084</b>		
Alternator Freewheel Clutch	2.0 D-4D, 2.2 D-4D, 2.2 D-CAT		<b>F5-1152</b>		
<b>YARIS/VITZ (SCP1_, NLP1_, NCP1_)</b>			<b>04/1999 → 09/2005</b>		
Dust Cover Kit, shock absorber	1.0 16V, 1.3, 1.3 16V, 1.4 D-4D, 1.5 TS, 1.5 VVT-i TS		<b>AK-735287</b>		
Dust Cover Kit, shock absorber	1.0 16V, 1.3, 1.3 16V, 1.4 D-4D, 1.5 TS, 1.5 VVT-i TS		<b>AK-735288</b>		
Alternator Freewheel Clutch	1.4 D-4D		<b>F5-1133</b>		
Anti-Friction Bearing	1.0 16V	08/2005 →	<b>F8-6266</b>		
Anti-Friction Bearing	1.3, 1.3 16V, 1.4 D-4D		<b>F8-6266</b>		
Top Strut Mounting	1.0 16V, 1.3, 1.3 16V, 1.4 D-4D		<b>F8-7474</b>		
Control Arm-/Trailing Arm Bush	1.0 16V, 1.3 16V, 1.4 D-4D, 1.5 TS, 1.5 VVT-i TS		<b>F8-8229</b>		
<b>YARIS/VITZ (SCP9_, NSP9_, KSP9_, NCP9_, ZSP9_)</b>			<b>08/2005 →</b>		
Dust Cover Kit, shock absorber	1.0 VVT-i, 1.3 VVT-i, 1.4 D-4D, 1.8 VVT-i		<b>AK-735289</b>		
Dust Cover Kit, shock absorber	1.0 VVT-i, 1.3 VVT-i, 1.4 D-4D, 1.8 VVT-i		<b>AK-735290</b>		
Alternator Freewheel Clutch	1.4 D-4D		<b>F5-1145</b>		
Alternator Freewheel Clutch	1.3 VVT-i		<b>F5-1152</b>		
Anti-Friction Bearing	1.0 VVT-i, 1.3 VVT-i, 1.33 VVT-i, 1.4 D-4D, 1.8 VVT-i		<b>F8-6266</b>		
Belt Pulley, crankshaft	1.4 D-4D		<b>F8-7867</b>		
<b>YARIS/VITZ (NHP13_, NSP13_, NCP13_, KSP13_, NLP13_)</b>			<b>03/2012 →</b>		
Anti-Friction Bearing	1.5 Hybrid		<b>F8-6266</b>		

<b>AK-735115</b>	<b>AK-735287</b>	<b>AK-735288</b>	<b>AK-735289</b>	<b>AK-735290</b>	<b>F5-1074</b>	<b>F5-1084</b>
Ref.Nr.:	Ref.Nr.: 481570D010	Ref.Nr.: 4875052010	Ref.Nr.: 48331-52080	Ref.Nr.: 487500D050	Ref.Nr.: 27415-0W130	Ref.Nr.: 2706030080
<b>F5-1133</b>	<b>F5-1145</b>	<b>F5-1152</b>	<b>F8-6266</b>	<b>F8-7474</b>	<b>F8-7867</b>	<b>F8-7868</b>
Ref.Nr.: 27415-33020	Ref.Nr.: 27415-33060	Ref.Nr.: 27415-26010	Ref.Nr.: 5035C2	Ref.Nr.: 48609-52021	Ref.Nr.: 13407-0N010	Ref.Nr.: 13408-0R011
<b>F8-8229</b>						
Ref.Nr.: 48069-59055						



Article Description

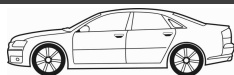

Article Nr.

Fitting Position



<b>YARIS VERSO (_NLP2_, _NCP2_)</b>		<b>08/1999 → 09/2005</b>	
Dust Cover Kit, shock absorber	1.3, 1.4 D-4D, 1.5	<b>AK-735287</b>	
Dust Cover Kit, shock absorber	1.3, 1.4 D-4D, 1.5	<b>AK-735288</b>	
Alternator Freewheel Clutch	1.4 D-4D	<b>F5-1133</b>	
Top Strut Mounting	1.3, 1.5	<b>F8-7474</b>	
Control Arm-/Trailing Arm Bush	1.3, 1.4 D-4D, 1.5	<b>F8-8229</b>	
<b>AURIS TOURING SPORTS (ADE18_, ZWE18_, ZRE18_)</b>		<b>07/2013 →</b>	
Alternator Freewheel Clutch	2.0 D-4D	<b>F5-1084</b>	

<b>AK-735287</b>	<b>AK-735288</b>	<b>F5-1084</b>	<b>F5-1133</b>	<b>F8-7474</b>	<b>F8-8229</b>
Ref.Nr.: 481570D010	Ref.Nr.: 4875052010	Ref.Nr.: 2706030080	Ref.Nr.: 27415-33020	Ref.Nr.: 48609-52021	Ref.Nr.: 48069-59055

Article Description			Article Nr.	Fitting Position	
---------------------	--	--	-------------	------------------	--

<b>ADAM</b>			10/2012 →		
Top Strut Mounting	1.2, 1.4		F8-7421		
Spring Cap	1.2, 1.4		F8-7422		
Top Strut Mounting	1.2, 1.4		F8-7423		
Top Strut Mounting	1.2, 1.4		F8-7424		
Rubber Buffer, suspension	1.2, 1.4		F8-7662		H=40
Protective Cap/Bellow, shock absorber	1.2, 1.4		F8-7663		H=205
<b>AGILA Mk I (A)</b>			02/2000 → 03/2008		
Dust Cover Kit, shock absorber	1.0 12V, 1.2 16V	ch.→YG 999 999	AK-735078		
Dust Cover Kit, shock absorber	1.0 12V, 1.2 16V, 1.2 16V Twinport		AK-735247		
Alternator Freewheel Clutch	1.0 12V, 1.2 16V Twinport		F5-1041		
Alternator Freewheel Clutch	1.0 12V, 1.2 16V Twinport		F5-1045		
Control Arm-/Trailing Arm Bush	1.0 12V, 1.2 16V, 1.2 16V Twinport		F8-6585		
Control Arm-/Trailing Arm Bush	All Models		F8-7857		
Repair Kit, link	All Models		F8-7857S		
<b>AGILA Mk II (B)</b>			01/2008 → 11/2014		
Dust Cover Kit, shock absorber	1.0 12V, 1.2, 1.2 i 16V, 1.3 CDTI		AK-735437		H=180
Alternator Freewheel Clutch	1.3 CDTI		F5-1041		
Rubber Buffer, suspension	1.0 12V, 1.2, 1.2 i 16V, 1.3 CDTI		F8-7326		H=180
Top Strut Mounting	All Models		F8-7624		
<b>ARENA Combi</b>			03/1998 → 08/2001		
Bellow, steering	All Models	with clamps;	LM-10002S		d1=10; d2=40; L [mm]=160
<b>ARENA Van</b>			03/1998 → 08/2001		
Bellow, steering	All Models	with clamps;	LM-10002S		d1=10; d2=40; L [mm]=160
<b>ASTRA Hatchback</b>			09/1979 → 08/1986		
Dust Cover Kit, shock absorber	1.2 S, 1.3 S, 1.6 D, 1.6 S, 1.8 GTE		AK-735003		
Control Arm-/Trailing Arm Bush	1.2 S, 1.3 S, 1.6 D, 1.6 S, 1.8 GTE		G9-591		H=59; d=14.5; D1=39; D2=44
Control Arm-/Trailing Arm Bush	1.2 S, 1.3 S, 1.6 D, 1.6 S, 1.8 GTE		G9-592		H=54; d=6; d1=6; d2=23
Bellow, steering	1.2 S, 1.3 S, 1.6 D, 1.6 S, 1.8 GTE	with clamps	LM-10045S		d1=42; d2=52; L [mm]=165
Bellow, steering	1.2 S, 1.3 S, 1.6 D, 1.6 S, 1.8 GTE		M-822300		
Bellow Set, drive shaft	1.6 D, 1.6 S, 1.8 GTE		MK-822920		

<b>AK-735003</b>	<b>AK-735078</b>	<b>AK-735247</b>	<b>AK-735437</b>	<b>F5-1041</b>	<b>F5-1045</b>	<b>F8-6585</b>
Ref.Nr.: 4708288	Ref.Nr.: 4705664	Ref.Nr.: 4705518	Ref.Nr.: 4708288	Ref.Nr.: 77364723	Ref.Nr.: 77362721	Ref.Nr.: 96 380 613
<b>F8-7326</b>	<b>F8-7421</b>	<b>F8-7422</b>	<b>F8-7423</b>	<b>F8-7424</b>	<b>F8-7624</b>	<b>F8-7662</b>
Ref.Nr.: 4708288	Ref.Nr.: 51813225	Ref.Nr.: 344963	Ref.Nr.: 55701902	Ref.Nr.: 55703318	Ref.Nr.: 41710-57K00	Ref.Nr.: 0344956
<b>F8-7663</b>	<b>F8-7857</b>	<b>F8-7857S</b>	<b>G9-591</b>	<b>G9-592</b>	<b>LM-10002S</b>	<b>LM-10045S</b>
Ref.Nr.: 344435	Ref.Nr.: 9209466	Ref.Nr.: 42451-76G00	Ref.Nr.: 90193117	Ref.Nr.: 352335	Ref.Nr.: 7700706007	Ref.Nr.: 26024585



**Article Description****Article Nr.****Fitting Position**

<b>ASTRA Estate</b>			<b>09/1979 → 08/1986</b>		
Dust Cover Kit, shock absorber	1.3 S, 1.6 D, 1.6 S		<b>AK-735003</b>		
Control Arm-/Trailing Arm Bush	1.3 S, 1.6 D, 1.6 S		<b>G9-591</b>		H=59; d=14.5; D1=39; D2=44
Control Arm-/Trailing Arm Bush	1.3 S, 1.6 D, 1.6 S		<b>G9-592</b>		H=54; d=6; d1=6; d2=23
Bellow, steering	1.3 S, 1.6 D, 1.6 S	with clamps	<b>LM-10045S</b>		d1=42; d2=52; L [mm]=165
Bellow, steering	1.3 S, 1.6 D, 1.6 S		<b>M-822300</b>		
Bellow Set, drive shaft	1.6 D, 1.6 S		<b>MK-822920</b>		
<b>ASTRA Mk II Belmont</b>			<b>09/1985 → 12/1991</b>		
Dust Cover Kit, shock absorber	1.3, 1.4 i, 1.6, 1.6 D, 1.6 S, 1.7 D, 1.8, 1.8 i		<b>AK-735003</b>		
Top Strut Mounting	1.6 D, 1.6 S, 1.7 D		<b>F8-3059</b>		d1=14; d2=37; D=78; T [mm]=132
Mounting, axle beam	1.3, 1.4 i, 1.5 DT, 1.6, 1.6 D, 1.6 S, 1.7 D, 1.8, 1.8 i		<b>F8-3060</b>		H=75; d=12; D1=49; D2=57
Top Strut Mounting	1.3, 1.4 i, 1.6		<b>F8-5589</b>		
Rubber Buffer, suspension	1.3, 1.4 i, 1.5 DT, 1.6, 1.6 D, 1.7 D, 1.8 i		<b>F8-7584</b>		H=68
Engine Mounting	1.3, 1.5 DT, 1.7 D		<b>F8-8145</b>		
Control Arm-/Trailing Arm Bush	1.3, 1.4 i, 1.5 DT, 1.6, 1.6 D, 1.6 S, 1.7 D, 1.8, 1.8 i		<b>G9-591</b>		H=59; d=14.5; D1=39; D2=44
Control Arm-/Trailing Arm Bush	1.3, 1.4 i, 1.5 DT, 1.6, 1.6 D, 1.6 S, 1.7 D, 1.8, 1.8 i		<b>G9-592</b>		H=54; d=6; d1=6; d2=23
Bellow, steering	1.3, 1.4 i, 1.5 DT, 1.6, 1.6 D, 1.6 S, 1.7 D, 1.8, 1.8 i	with clamps	<b>LM-10045S</b>		d1=42; d2=52; L [mm]=165
Bellow, steering	1.3, 1.4 i, 1.5 DT, 1.6, 1.6 D, 1.6 S, 1.7 D, 1.8, 1.8 i		<b>M-822300</b>		
<b>ASTRA Mk II Hatchback</b>			<b>09/1984 → 08/1991</b>		
Dust Cover Kit, shock absorber	1.2, 1.3, 1.4 S, 1.6, 1.6 D, 1.6 S, 1.7 D, 1.8 GTE, 2.0 GTE, 2.0 GTE 16V		<b>AK-735003</b>		
Top Strut Mounting	1.6, 1.6 D, 1.6 S, 1.7 D		<b>F8-3059</b>		d1=14; d2=37; D=78; T [mm]=132
Mounting, axle beam	1.2, 1.3, 1.4 i, 1.4 S, 1.6, 1.6 D, 1.6 S, 1.7 D, 1.8 GTE, 2.0 GTE, 2.0 GTE 16V		<b>F8-3060</b>		H=75; d=12; D1=49; D2=57
Mounting, alternator	1.2, 1.3, 1.4 i, 1.4 S, 1.6		<b>F8-5366</b>		
Top Strut Mounting	1.2, 1.3, 1.4 i, 1.4 S, 1.6		<b>F8-5589</b>		
Rubber Buffer, suspension	2.0 GTE 16V		<b>F8-5710</b>		H=46
Rubber Buffer, suspension	1.2, 1.3, 1.4 i, 1.4 S, 1.6, 1.6 S, 1.7 D, 1.8 GTE, 2.0, 2.0 GTE		<b>F8-7584</b>		H=68
Engine Mounting	1.3, 1.4 i, 1.4 S, 1.6, 1.7 D, 1.8 GTE, 2.0 GTE 16V		<b>F8-8145</b>		
Control Arm-/Trailing Arm Bush	1.2, 1.3, 1.4 i, 1.4 S, 1.6, 1.6 D, 1.6 S, 1.7 D, 1.8 GTE, 2.0 GTE, 2.0 GTE 16V		<b>G9-591</b>		H=59; d=14.5; D1=39; D2=44
Control Arm-/Trailing Arm Bush	1.2, 1.3, 1.4 i, 1.4 S, 1.6, 1.6 D, 1.6 S, 1.7 D, 1.8 GTE, 2.0 GTE, 2.0 GTE 16V		<b>G9-592</b>		H=54; d=6; d1=6; d2=23
Bellow, steering	All Models	with clamps	<b>LM-10045S</b>		d1=42; d2=52; L [mm]=165
Bellow, steering	All Models		<b>M-822300</b>		

<b>AK-735003</b>	<b>F8-3059</b>	<b>F8-3060</b>	<b>F8-5366</b>	<b>F8-5589</b>	<b>F8-5710</b>	<b>F8-7584</b>
Ref.Nr.:	Ref.Nr.: 344509	Ref.Nr.: 90189050	Ref.Nr.: 1204885	Ref.Nr.: 344508	Ref.Nr.: 0344402	Ref.Nr.: 0344401
<b>F8-8145</b>	<b>G9-591</b>	<b>G9-592</b>	<b>LM-10045S</b>	<b>M-822300</b>	<b>MK-822920</b>	
Ref.Nr.: 90189509	Ref.Nr.: 90193117	Ref.Nr.: 352335	Ref.Nr.: 26024585	Ref.Nr.: 90090811	Ref.Nr.: 811498203	

<b>Article Description</b>			<b>Article Nr.</b>	<b>Fitting Position</b>	
----------------------------	--	--	--------------------	-------------------------	--

<b>ASTRA Mk II Hatchback</b>			<b>09/1984 → 08/1991</b>		
Bellow Set, drive shaft	1.6, 1.6 D, 1.6 S, 1.7 D, 1.8 GTE		<b>MK-822920</b>		
<b>ASTRA Mk II Convertible</b>			<b>01/1987 → 08/1993</b>		
Mounting, axle beam	All Models		<b>F8-3060</b>		H=75; d=12; D1=49; D2=57
Mounting, alternator	1.6 i		<b>F8-5366</b>		
Engine Mounting	2.0 i CAT	ch.P2500001, P3000001, P4000001, P5000001, P8100001→;	<b>F8-5418</b>		
Engine Mounting	2.0 i CAT		<b>F8-5436</b>		
Engine Mounting	2.0 i CAT		<b>F8-5439</b>		
Top Strut Mounting	1.6 i		<b>F8-5589</b>		
Rubber Buffer, suspension	2.0 i CAT	ch.S2500001, S5000001, S6000001, S8000001→;	<b>F8-5710</b>		
Control Arm-/Trailing Arm Bush	1.6 i, 1.6 i CAT, 2.0 i CAT	ch.P2603823, P5000000, P8146890, PB000001→; ch.→R2587415, R5111734, R8145949, RB011797	<b>F8-5968</b>		
Sleeve, control arm mounting	1.6 i, 1.6 i CAT, 2.0 i CAT		<b>F8-6656</b>		
Rubber Buffer, suspension	1.6 i, 2.0 i		<b>F8-7584</b>		
Engine Mounting	1.6 i		<b>F8-8145</b>		
Control Arm-/Trailing Arm Bush	All Models		<b>G9-591</b>		
Control Arm-/Trailing Arm Bush	All Models		<b>G9-592</b>		
Bellow, steering	All Models	with clamps	<b>LM-10045S</b>		d1=42; d2=52; L [mm]=165
Bellow Set, drive shaft	1.6 i CAT		<b>M-820820</b>		
Bellow, steering	All Models		<b>M-822300</b>		
C.V. Boot	2.0 i CAT	ch.N1000001, N2000001, N5000001→; ch.→N2733477, N5273484, P8202125	<b>M-822900</b>		
Bellow Set, drive shaft	1.6 i CAT		<b>MK-820820</b>		
Bellow Set, drive shaft	1.6 i, 1.6 i CAT, 2.0 i		<b>MK-822920</b>		
<b>ASTRA Mk II Estate</b>			<b>09/1984 → 08/1991</b>		
Dust Cover Kit, shock absorber	1.2, 1.3, 1.4 S, 1.6, 1.6 D, 1.6 S, 1.7 D		<b>AK-735003</b>		
Top Strut Mounting	1.6 D, 1.6 S, 1.7 D		<b>F8-3059</b>		
Mounting, alternator	1.2, 1.3, 1.4 S, 1.6		<b>F8-5366</b>		
Top Strut Mounting	1.2, 1.3, 1.4 S, 1.6, 1.6 D		<b>F8-5589</b>		
Rubber Buffer, suspension	1.2, 1.3, 1.4 S, 1.6, 1.6 D, 1.6 S, 1.7 D, 1.8 i		<b>F8-7584</b>		
Engine Mounting	1.3, 1.4 S, 1.6, 1.6 D, 1.7 D		<b>F8-8145</b>		
Control Arm-/Trailing Arm Bush	1.2, 1.3, 1.4 S, 1.5 DT, 1.6, 1.6 D, 1.6 S, 1.7 D, 1.8 i		<b>G9-591</b>		

<b>AK-735003</b>	<b>F8-3059</b>	<b>F8-3060</b>	<b>F8-5366</b>	<b>F8-5418</b>	<b>F8-5436</b>	<b>F8-5439</b>
Ref.Nr.:	Ref.Nr.: 344509	Ref.Nr.: 90189050	Ref.Nr.: 1204885	Ref.Nr.: 684646	Ref.Nr.: 0684641	Ref.Nr.: 684289
<b>F8-5589</b>	<b>F8-5710</b>	<b>F8-5968</b>	<b>F8-6656</b>	<b>F8-7584</b>	<b>F8-8145</b>	<b>G9-591</b>
Ref.Nr.: 344508	Ref.Nr.: 0344402	Ref.Nr.: 352351	Ref.Nr.: 4246062	Ref.Nr.: 0344401	Ref.Nr.: 90189509	Ref.Nr.: 90193117
<b>G9-592</b>	<b>LM-10045S</b>		<b>M-822300</b>	<b>M-822900</b>	<b>MK-820820</b>	<b>MK-822920</b>
Ref.Nr.: 352335	Ref.Nr.: 26024585	Ref.Nr.: 1603146	Ref.Nr.: 90090811	Ref.Nr.: 90421747	Ref.Nr.: 1603179	Ref.Nr.: 811498203



Article Description



Article Nr.

Fitting Position



<b>ASTRA Mk II Estate</b>				<b>09/1984 → 08/1991</b>	
Control Arm-/Trailing Arm Bush	1.2, 1.3, 1.4 S, 1.5 DT, 1.6, 1.6 D, 1.6 S, 1.7 D, 1.8 i		<b>G9-592</b>		H=54; d=6; d1=6; d2=23
Bellow, steering	All Models	with clamps	<b>LM-10045S</b>		d1=42; d2=52; L [mm]=165
Bellow, steering	All Models		<b>M-822300</b>		
Bellow Set, drive shaft	1.6, 1.6 D, 1.6 S, 1.7 D, 1.8 i		<b>MK-822920</b>		
<b>ASTRA Mk III (F)</b>				<b>12/1991 → 09/1998</b>	
Anti-Friction Bearing	1.4 i, 1.4 i 16V, 1.6 i, 1.6 i 16V, 1.7 D, 1.7 TD, 1.8 i, 1.8 i 16V, 2.0 i, 2.0 i 16V	ch.→T2677310	<b>F8-3025</b>		d=22
Mounting, axle beam	1.4 i, 1.4 i 16V, 1.6 i, 1.6 i 16V, 1.7 D, 1.7 TD, 1.8 i, 1.8 i 16V, 2.0 i, 2.0 i 16V		<b>F8-4102</b>		H=74; d=12; D1=60; D2=66
Top Strut Mounting	1.4 i, 1.4 i 16V, 1.6 i, 1.6 i 16V, 1.7 D, 1.7 TD, 1.8 i, 1.8 i 16V, 2.0 i, 2.0 i 16V		<b>F8-5304</b>		
Top Strut Mounting	1.4 i, 1.4 i 16V, 1.6 i, 1.6 i 16V, 1.7 D, 1.7 TD, 1.8 i, 1.8 i 16V, 2.0 i, 2.0 i 16V		<b>F8-5304S</b>		
Control Arm-/Trailing Arm Bush	1.4 i, 1.4 i 16V, 1.6 i, 1.6 i 16V, 1.7 D, 1.7 TD, 1.8 i, 1.8 i 16V, 2.0 i, 2.0 i 16V		<b>F8-5334</b>		d=16; D=60; Thick. [mm]=58
Mounting, alternator	1.4 i, 1.6 i		<b>F8-5366</b>		
Engine Mounting	1.4 i		<b>F8-5372</b>		
Engine Mounting	1.4 i		<b>F8-5372</b>		
Engine Mounting	1.4 i 16V, 1.6 i 16V		<b>F8-5372</b>		
Engine Mounting	1.6 i		<b>F8-5372</b>		
Engine Mounting	1.6 i		<b>F8-5372</b>		
Engine Mounting	1.6 i		<b>F8-5372</b>		
Engine Mounting	1.7 TD		<b>F8-5391</b>		
Engine Mounting	1.8 i	ch.P2500001, P3000001, P4000001, P5000001, P8000001→;	<b>F8-5418</b>		
Engine Mounting	1.8 i 16V, 2.0 i 16V		<b>F8-5418</b>		
Engine Mounting	2.0 i	ch.P2500001, P3000001, P4000001, P5000001, P8100001→;	<b>F8-5418</b>		
Engine Mounting	1.8 i 16V, 2.0 i, 2.0 i 16V		<b>F8-5436</b>		
Engine Mounting	2.0 i	ch.N2500001→; ch.→N2999999	<b>F8-5438</b>		
Engine Mounting	1.4 i, 1.6 i 16V, 2.0 i		<b>F8-5439</b>		
Engine Mounting	1.7 D, 1.7 TD		<b>F8-5439</b>		
Engine Mounting	1.4 i, 1.4 i 16V, 1.6 i, 1.6 i 16V, 1.7 TD		<b>F8-5444</b>		
Engine Mounting	1.7 D, 1.7 TD		<b>F8-5445</b>		
Engine Mounting	2.0 i	ch.→NA299999	<b>F8-5445</b>		
Top Strut Mounting	1.6 i, 1.7 TD, 2.0 i 16V	Bearing Type: Soft Version;	<b>F8-5448</b>		
Engine Mounting	1.7 TD		<b>F8-5462</b>		

<b>F8-3025</b>	<b>F8-4102</b>	<b>F8-5304</b>	<b>F8-5304S</b>	<b>F8-5334</b>	<b>F8-5366</b>	<b>F8-5372</b>
Ref.Nr.: 90374844	Ref.Nr.: 90372559	Ref.Nr.: 0344517	Ref.Nr.: 344531	Ref.Nr.: 352356	Ref.Nr.: 1204885	Ref.Nr.: 90278345
<b>F8-5391</b>	<b>F8-5418</b>	<b>F8-5436</b>	<b>F8-5438</b>	<b>F8-5439</b>	<b>F8-5444</b>	<b>F8-5445</b>
Ref.Nr.: 684643	Ref.Nr.: 684646	Ref.Nr.: 0684641	Ref.Nr.: 684291	Ref.Nr.: 684289	Ref.Nr.: 90473852	Ref.Nr.: 0682504
<b>F8-5448</b>	<b>F8-5462</b>	<b>F8-5463</b>	<b>G9-592</b>	<b>LM-10045S</b>	<b>M-822300</b>	<b>MK-822920</b>
Ref.Nr.: 0344523	Ref.Nr.: 684644	Ref.Nr.: 0344525	Ref.Nr.: 352335	Ref.Nr.: 26024585	Ref.Nr.: 90090811	Ref.Nr.: 811498203

Article Description



Article Nr.

Fitting Position



ASTRA Mk III (F)			12/1991 → 09/1998	
Top Strut Mounting	1.6 i, 1.7 TD, 2.0 i 16V		<b>F8-5463</b>	
Engine Mounting	1.6 i		<b>F8-5467</b>	
Engine Mounting	1.4 i, 1.6 i		<b>F8-5468</b>	
Engine Mounting	1.6 i		<b>F8-5468</b>	
Engine Mounting	1.7 D, 1.7 TD		<b>F8-5468</b>	
Engine Mounting	1.8 i	ch.N2500001, N4000001, N5000001, NA100001, NE100001→; ch.→N2999999, N4999999, N5999999, NA299999, NE299999	<b>F8-5468</b>	
Rubber Buffer, suspension	1.4 i, 1.4 i 16V, 1.6 i 16V		<b>F8-5710</b>	
Rubber Buffer, suspension	1.6 i		<b>F8-5710</b>	
Rubber Buffer, suspension	1.7 TD	ch.S2500001, S5000001, S6000001, S8000001→; Sport;	<b>F8-5710</b>	
Rubber Buffer, suspension	1.7 TD		<b>F8-5710</b>	
Rubber Buffer, suspension	1.8 i 16V, 2.0 i	ch.S2500001, S5000001, S6000001, S8000001→;	<b>F8-5710</b>	
Rubber Buffer, suspension	2.0 i 16V	Sport;	<b>F8-5710</b>	
Control Arm-/Trailing Arm Bush	1.4 i, 1.6 i, 1.6 i 16V, 1.7 D, 1.7 TD, 1.8 i, 1.8 i 16V, 2.0 i, 2.0 i 16V	ch.P2603823, P5000000, P8146890, PB000001→; ch.→R2587415, R5111734, R8145949, RB011797	<b>F8-5968</b>	
Control Arm-/Trailing Arm Bush	1.4 i, 1.4 i 16V, 1.6 i, 1.6 i 16V, 1.7 D, 1.7 TD, 1.8 i, 1.8 i 16V, 2.0 i, 2.0 i 16V	ch.P2603823, P5000000, P8146890, PB000001→; ch.→R2587415, R5111734, R8145949, RB011797	<b>F8-5969</b>	
Sleeve, control arm mounting	1.4 i, 1.4 i 16V, 1.6 i, 1.6 i 16V, 1.7 D, 1.7 TD, 1.8 i, 1.8 i 16V, 2.0 i, 2.0 i 16V		<b>F8-6656</b>	
Engine Mounting	1.4 i 16V, 1.6 i		<b>F8-8195</b>	
Control Arm-/Trailing Arm Bush	1.4 i, 1.4 i 16V, 1.6 i, 1.6 i 16V, 1.7 D, 1.7 TD, 1.8 i, 1.8 i 16V, 2.0 i, 2.0 i 16V		<b>G9-593</b>	
Control Arm-/Trailing Arm Bush	1.4 i, 1.4 i 16V, 1.6 i, 1.6 i 16V, 1.7 D, 1.7 TD, 1.8 i, 1.8 i 16V, 2.0 i, 2.0 i 16V		<b>G9-594</b>	
C.V. Boot	1.7 D, 1.7 TD, 1.8 i, 1.8 i 16V, 2.0 i	ch.N1000001, N2000001, N5000001→; ch.→N2733477, N5273484, P8202125	<b>M-822900</b>	
Bellow Set, drive shaft	1.7 D, 1.7 TD, 1.8 i, 2.0 i, 2.0 i 16V		<b>MK-822920</b>	
ASTRA Mk III (F) Hatchback			09/1991 → 02/1998	
Anti-Friction Bearing	1.4 i, 1.4 i 16V, 1.6 i, 1.6 i 16V, 1.7 D, 1.7 TD, 1.8 i, 1.8 i 16V, 2.0 i, 2.0 i 16V	ch.→T2677310	<b>F8-3025</b>	
Mounting, axle beam	All Models		<b>F8-4102</b>	
Top Strut Mounting	All Models		<b>F8-5304</b>	
Top Strut Mounting	All Models		<b>F8-5304S</b>	
Control Arm-/Trailing Arm Bush	All Models		<b>F8-5334</b>	



**Article Description****Article Nr.****Fitting Position**

<b>ASTRA Mk III (F) Hatchback</b>			<b>09/1991 → 02/1998</b>		
Mounting, alternator	1.4 i, 1.6 i		<b>F8-5366</b>		
Engine Mounting	1.4 i		<b>F8-5372</b>		
Engine Mounting	1.4 i 16V, 1.6 i 16V		<b>F8-5372</b>		
Engine Mounting	1.4 i, 1.4 S		<b>F8-5372</b>		
Engine Mounting	1.6 i		<b>F8-5372</b>		
Engine Mounting	1.6 i		<b>F8-5372</b>		
Engine Mounting	1.6 i		<b>F8-5372</b>		
Engine Mounting	1.7 TD		<b>F8-5391</b>		
Engine Mounting	1.8 i	ch.P2500001, P3000001, P4000001, P5000001, P8000001→;	<b>F8-5418</b>		
Engine Mounting	1.8 i 16V, 2.0 i 16V		<b>F8-5418</b>		
Engine Mounting	2.0 i, 2.0 i 16V	ch.P2500001, P3000001, P4000001, P5000001, P8100001→;	<b>F8-5418</b>		
Engine Mounting	1.8 i 16V, 2.0 i, 2.0 i 16V		<b>F8-5436</b>		
Engine Mounting	1.4 S		<b>F8-5438</b>		
Engine Mounting	2.0 i	ch.N2500001→; ch.→N2999999	<b>F8-5438</b>		
Engine Mounting	1.4 i, 1.4 i 16V, 1.6 i 16V, 2.0 i, 2.0 i 16V		<b>F8-5439</b>		
Engine Mounting	1.7 D, 1.7 TD		<b>F8-5439</b>		
Engine Mounting	1.4 i, 1.4 i 16V, 1.6 i, 1.6 i 16V, 1.7 TD		<b>F8-5444</b>		
Engine Mounting	1.7 D, 1.7 TD		<b>F8-5445</b>		
Engine Mounting	2.0 i	ch.→NA299999	<b>F8-5445</b>		
Top Strut Mounting	1.6 i, 1.7 TD, 2.0 i 16V	Bearing Type: Soft Version;	<b>F8-5448</b>		
Engine Mounting	1.7 TD		<b>F8-5462</b>		
Top Strut Mounting	1.6 i, 1.7 TD, 2.0 i 16V		<b>F8-5463</b>		
Engine Mounting	1.6 i		<b>F8-5467</b>		
Engine Mounting	1.6 i		<b>F8-5467</b>		
Engine Mounting	1.4 i, 1.4 S, 1.6 i		<b>F8-5468</b>		
Engine Mounting	1.6 i		<b>F8-5468</b>		
Engine Mounting	1.7 D, 1.7 TD		<b>F8-5468</b>		
Engine Mounting	1.8 i, 2.0 i 16V	ch.N2500001, N4000001, N5000001, NA100001, NE100001→; ch.→N2999999, N4999999, N5999999, NA299999, NE299999	<b>F8-5468</b>		
Rubber Buffer, suspension	1.4 i, 1.4 i 16V, 1.6 i 16V	; not for equipment variant: Sport;	<b>F8-5710</b>		H=46
Rubber Buffer, suspension	1.6 i		<b>F8-5710</b>		H=46
Rubber Buffer, suspension	1.7 TD		<b>F8-5710</b>		H=46
Rubber Buffer, suspension	1.7 TD		<b>F8-5710</b>		H=46



Article Description



Article Nr.

Fitting Position



<b>ASTRA Mk III (F) Hatchback</b>			<b>09/1991 → 02/1998</b>		
Rubber Buffer, suspension	1.8 i 16V, 2.0 i	ch.S2500001, S5000001, S6000001, S8000001→;	<b>F8-5710</b>		H=46
Rubber Buffer, suspension	2.0 i 16V	Sport;	<b>F8-5710</b>		H=46
Rubber Buffer, suspension	2.0 i 16V		<b>F8-5710</b>		H=46
Control Arm-/Trailing Arm Bush	1.4 i, 1.4 i 16V, 1.6 i, 1.6 i 16V, 1.7 D, 1.7 TD, 1.8 i, 1.8 i 16V, 2.0 i, 2.0 i 16V	ch.P2603823, P5000000, P8146890, PB000001→; ch.→R2587415, R5111734, R8145949, RB011797	<b>F8-5968</b>		d=12
Control Arm-/Trailing Arm Bush	All Models	ch.P2603823, P5000000, P8146890, PB000001→; ch.→R2587415, R5111734, R8145949, RB011797	<b>F8-5969</b>		H=58; d=16; D=60
Sleeve, control arm mounting	All Models		<b>F8-6656</b>		
Rubber Buffer, suspension	2.0 i 16V	<b>ST</b>	<b>F8-7584</b>		H=68
Control Arm-/Trailing Arm Bush	All Models		<b>G9-593</b>		d=12; D1=39; D2=44
Control Arm-/Trailing Arm Bush	All Models		<b>G9-594</b>		H1=27; H2=58; d=16; D1=60; D2=66
C.V. Boot	1.7 D, 1.7 TD, 1.8 i, 1.8 i 16V, 2.0 i, 2.0 i 16V	ch.N1000001, N2000001, N5000001→; ch.→N2733477, N5273484, P8202125	<b>M-822900</b>		
Bellow Set, drive shaft	1.7 D, 1.7 TD, 1.8 i, 2.0 i, 2.0 i 16V		<b>MK-822920</b>		
<b>ASTRA Mk III (F) Convertible</b>			<b>03/1993 → 03/2001</b>		
Alternator Freewheel Clutch	1.4 i 16V, 1.6 i		<b>F5-1050</b>		
Anti-Friction Bearing	1.4 i, 1.4 i 16V, 1.6 i, 1.8 16V, 2.0 i	ch.→T2677310	<b>F8-3025</b>		d=22
Mounting, axle beam	1.4 i, 1.4 i 16V, 1.6 i, 1.8 16V, 2.0 i		<b>F8-4102</b>		H=74; d=12; D1=60; D2=66
Top Strut Mounting	1.4 i, 1.4 i 16V, 1.6 i, 1.8 16V, 2.0 i		<b>F8-5304</b>		
Top Strut Mounting	1.4 i, 1.4 i 16V, 1.6 i, 1.8 16V, 2.0 i		<b>F8-5304S</b>		
Control Arm-/Trailing Arm Bush	1.4 i, 1.4 i 16V, 1.6 i, 1.8 16V, 2.0 i		<b>F8-5334</b>		d=16; D=60; Thick. [mm]=58
Mounting, alternator	1.6 i		<b>F8-5366</b>		
Engine Mounting	1.4 i		<b>F8-5372</b>		
Engine Mounting	1.4 i 16V		<b>F8-5372</b>		
Engine Mounting	1.6		<b>F8-5372</b>		
Engine Mounting	1.6 i		<b>F8-5372</b>		
Engine Mounting	1.8, 1.8 16V		<b>F8-5418</b>		
Engine Mounting	2.0 i	ch.P2500001, P3000001, P4000001, P5000001, P8100001→;	<b>F8-5418</b>		
Engine Mounting	1.8, 1.8 16V, 2.0 i		<b>F8-5436</b>		
Engine Mounting	2.0 i	ch.N2500001→; ch.→N2999999	<b>F8-5438</b>		
Engine Mounting	1.4 i, 2.0 i		<b>F8-5439</b>		
Engine Mounting	1.4 i, 1.4 i 16V, 1.6 i		<b>F8-5444</b>		

<b>F5-1050</b>	<b>F8-3025</b>	<b>F8-4102</b>	<b>F8-5304</b>	<b>F8-5304S</b>	<b>F8-5334</b>	<b>F8-5366</b>
Ref.Nr.: 1204412	Ref.Nr.: 90374844	Ref.Nr.: 90372559	Ref.Nr.: 0344517	Ref.Nr.: 344531	Ref.Nr.: 352356	Ref.Nr.: 1204885
<b>F8-5372</b>	<b>F8-5418</b>	<b>F8-5436</b>	<b>F8-5438</b>	<b>F8-5439</b>	<b>F8-5444</b>	<b>F8-5445</b>
Ref.Nr.: 90278345	Ref.Nr.: 684646	Ref.Nr.: 0684641	Ref.Nr.: 684291	Ref.Nr.: 684289	Ref.Nr.: 90473852	Ref.Nr.: 0682504
<b>F8-5710</b>	<b>F8-5968</b>	<b>F8-5969</b>	<b>F8-6656</b>	<b>F8-7584</b>	<b>G9-593</b>	<b>G9-594</b>
Ref.Nr.: 0344402	Ref.Nr.: 352351	Ref.Nr.: 352352	Ref.Nr.: 4246062	Ref.Nr.: 0344401	Ref.Nr.: 90288232	Ref.Nr.: 90268463

**Article Description****Article Nr.****Fitting Position**

<b>ASTRA Mk III (F) Convertible</b>			<b>03/1993 → 03/2001</b>	
Engine Mounting	2.0 i	ch.→NA299999	<b>F8-5445</b>	
Engine Mounting	1.6		<b>F8-5467</b>	
Engine Mounting	1.6 i		<b>F8-5467</b>	
Engine Mounting	1.4 i		<b>F8-5468</b>	
Engine Mounting	1.6 i		<b>F8-5468</b>	
Rubber Buffer, suspension	1.4 i, 1.4 i 16V		<b>F8-5710</b>	
Rubber Buffer, suspension	1.6 i		<b>F8-5710</b>	
Rubber Buffer, suspension	1.8, 1.8 16V, 2.0 i	ch.S2500001, S5000001, S6000001, S8000001→;	<b>F8-5710</b>	
Control Arm-/Trailing Arm Bush	1.4 i, 1.6, 1.6 i, 1.8, 1.8 16V, 2.0 i	ch.P2603823, P5000000, P8146890, PB000001→; ch.→R2587415, R5111734, R8145949, RB011797	<b>F8-5968</b>	
Control Arm-/Trailing Arm Bush	1.4 i, 1.4 i 16V, 1.6, 1.6 i, 1.8, 1.8 16V, 2.0 i	ch.P2603823, P5000000, P8146890, PB000001→; ch.→R2587415, R5111734, R8145949, RB011797	<b>F8-5969</b>	
Sleeve, control arm mounting	1.4 i, 1.6, 1.6 i, 1.8, 1.8 16V, 2.0 i		<b>F8-6656</b>	
Control Arm-/Trailing Arm Bush	1.4 i, 1.4 i 16V, 1.6 i, 1.8 16V, 2.0 i		<b>G9-593</b>	
Control Arm-/Trailing Arm Bush	1.4 i, 1.4 i 16V, 1.6 i, 1.8 16V, 2.0 i		<b>G9-594</b>	
C.V. Boot	1.8, 1.8 16V, 2.0 i	ch.N1000001, N2000001, N5000001→; ch.→N2733477, N5273484, P8202125	<b>M-822900</b>	
Bellow Set, drive shaft	2.0 i		<b>MK-822920</b>	
<b>ASTRA Mk III (F) Estate</b>			<b>03/1991 → 02/1998</b>	
Anti-Friction Bearing	1.4 i, 1.4 i 16V, 1.6 i, 1.6 Si, 1.7 D, 1.7 TD, 1.8 i, 1.8 i 16V, 2.0 i, 2.0 i 16V	ch.→T2677310	<b>F8-3025</b>	
Mounting, axle beam	All Models		<b>F8-4102</b>	
Top Strut Mounting	All Models		<b>F8-5304</b>	
Top Strut Mounting	All Models		<b>F8-5304S</b>	
Control Arm-/Trailing Arm Bush	All Models		<b>F8-5334</b>	
Mounting, alternator	1.4 i, 1.6 i, 1.6 Si		<b>F8-5366</b>	
Engine Mounting	1.4 i		<b>F8-5372</b>	
Engine Mounting	1.4 i 16V, 1.6 i 16V		<b>F8-5372</b>	
Engine Mounting	1.4 i, 1.4 S		<b>F8-5372</b>	
Engine Mounting	1.6 i		<b>F8-5372</b>	
Engine Mounting	1.6 i		<b>F8-5372</b>	
Engine Mounting	1.6 Si		<b>F8-5372</b>	
Engine Mounting	1.7 TD		<b>F8-5391</b>	

<b>F8-3025</b>	<b>F8-4102</b>	<b>F8-5304</b>	<b>F8-5304S</b>	<b>F8-5334</b>	<b>F8-5366</b>	<b>F8-5372</b>
Ref.Nr.: 90374844	Ref.Nr.: 90372559	Ref.Nr.: 0344517	Ref.Nr.: 344531	Ref.Nr.: 352356	Ref.Nr.: 1204885	Ref.Nr.: 90278345
<b>F8-5391</b>	<b>F8-5418</b>	<b>F8-5445</b>	<b>F8-5467</b>	<b>F8-5468</b>	<b>F8-5710</b>	<b>F8-5968</b>
Ref.Nr.: 684643	Ref.Nr.: 684646	Ref.Nr.: 0682504	Ref.Nr.: 0684285	Ref.Nr.: 0684283	Ref.Nr.: 0344402	Ref.Nr.: 352351
<b>F8-5969</b>	<b>F8-6656</b>	<b>G9-593</b>	<b>G9-594</b>	<b>M-822900</b>	<b>MK-822920</b>	
Ref.Nr.: 352352	Ref.Nr.: 4246062	Ref.Nr.: 90288232	Ref.Nr.: 90268463	Ref.Nr.: 90421747	Ref.Nr.: 811498203	

Article Description



Article Nr.

Fitting Position



**ASTRA Mk III (F) Estate**

03/1991 → 02/1998

Engine Mounting	1.8 i	ch.P2500001, P3000001, P4000001, P5000001, P8000001→;	<b>F8-5418</b>		
Engine Mounting	1.8 i 16V, 2.0 i 16V		<b>F8-5418</b>		
Engine Mounting	2.0 i	ch.P2500001, P3000001, P4000001, P5000001, P8100001→;	<b>F8-5418</b>		
Engine Mounting	1.8 i 16V, 2.0 i, 2.0 i 16V		<b>F8-5436</b>		
Engine Mounting	1.4 S		<b>F8-5438</b>		
Engine Mounting	2.0 i	ch.N2500001→; ch.→N2999999	<b>F8-5438</b>		
Engine Mounting	1.4 i, 1.4 i 16V, 1.6 i 16V, 2.0 i		<b>F8-5439</b>		
Engine Mounting	1.7 D, 1.7 TD		<b>F8-5439</b>		
Engine Mounting	1.4 i, 1.4 i 16V, 1.6 i, 1.6 i 16V, 1.6 Si, 1.7 TD		<b>F8-5444</b>		
Engine Mounting	1.7 D, 1.7 TD		<b>F8-5445</b>		
Engine Mounting	2.0 i	ch.→NA2999999	<b>F8-5445</b>		
Top Strut Mounting	1.6 i, 1.7 TD, 2.0 i 16V	Bearing Type: Soft Version;	<b>F8-5448</b>		
Engine Mounting	1.7 TD		<b>F8-5462</b>		
Top Strut Mounting	1.6 i, 1.7 TD, 2.0 i 16V	;	<b>F8-5463</b>		
Engine Mounting	1.6 i, 1.6 Si		<b>F8-5467</b>		
Engine Mounting	1.4 i, 1.4 S, 1.6 i, 1.6 Si		<b>F8-5468</b>		
Engine Mounting	1.6 i	; ;	<b>F8-5468</b>		
Engine Mounting	1.7 D, 1.7 TD		<b>F8-5468</b>		
Engine Mounting	1.8 i	ch.N2500001, N4000001, N5000001, NA100001, NE100001→; ch.→N2999999, N4999999, N5999999, NA2999999, NE2999999	<b>F8-5468</b>		
Rubber Buffer, suspension	1.4 i, 1.4 i 16V, 1.6 i 16V	; not for equipment variant: Sport;	<b>F8-5710</b>		H=46
Rubber Buffer, suspension	1.6 i	;	<b>F8-5710</b>		H=46
Rubber Buffer, suspension	1.7 TD		<b>F8-5710</b>		H=46
Rubber Buffer, suspension	1.7 TD	;	<b>F8-5710</b>		H=46
Rubber Buffer, suspension	1.8 i 16V, 2.0 i	ch.S2500001, S5000001, S6000001, S8000001→;	<b>F8-5710</b>		H=46
Rubber Buffer, suspension	2.0 i 16V	Sport;	<b>F8-5710</b>		H=46
Control Arm-/Trailing Arm Bush	1.4 i, 1.4 i 16V, 1.6 i, 1.6 i 16V, 1.6 Si, 1.7 D, 1.7 TD, 1.8 i, 1.8 i 16V, 2.0 i, 2.0 i 16V	ch.P2603823, P5000000, P8146890, PB000001→; ch.→R2587415, R5111734, R8145949, RB011797	<b>F8-5968</b>		d=12
Control Arm-/Trailing Arm Bush	All Models	ch.P2603823, P5000000, P8146890, PB000001→; ch.→R2587415, R5111734, R8145949, RB011797	<b>F8-5969</b>		H=58; d=16; D=60
Sleeve, control arm mounting	All Models		<b>F8-6656</b>		
Engine Mounting	1.4 i 16V		<b>F8-8195</b>		





**Article Description****Article Nr.****Fitting Position**

<b>ASTRA Mk III (F) Estate</b>			<b>03/1991 → 02/1998</b>		
Control Arm-/Trailing Arm Bush	All Models		<b>G9-593</b>		d=12; D1=39; D2=44
Control Arm-/Trailing Arm Bush	All Models		<b>G9-594</b>		H1=27; H2=58; d=16; D1=60; D2=66
C.V. Boot	1.7 D, 1.7 TD, 1.8 i, 1.8 i 16V, 2.0 i	ch.N1000001, N2000001, N5000001→; ch.→N2733477, N5273484, P8202125	<b>M-822900</b>		
Bellow Set, drive shaft	1.7 D, 1.7 TD, 1.8 i, 2.0 i, 2.0 i 16V		<b>MK-822920</b>		
<b>ASTRA Mk IV (G) Hatchback</b>			<b>02/1998 → 05/2005</b>		
Rubber Buffer, suspension	1.2 16V, 1.4 16V, 1.6, 1.6 16V, 1.6 Dualfuel, 1.7 CDTI 16V, 1.7 DTI 16V, 1.7 TD, 1.8 16V, 1.8 16V Dualfuel, 2.0 16V, 2.0 DI, 2.0 DTI 16V, 2.0 SRI Turbo, 2.2 16V		<b>AK-735038</b>		
Alternator Freewheel Clutch	1.2 16V, 1.4 16V		<b>F5-1041</b>		
Alternator Freewheel Clutch	1.2 16V, 1.4 16V		<b>F5-1045</b>		
Alternator Freewheel Clutch	1.7 CDTI 16V		<b>F5-1049</b>		
Alternator Freewheel Clutch	1.6, 1.6 16V, 1.6 Dualfuel, 1.8 16V, 2.0, 2.0 16V		<b>F5-1050</b>		
Control Arm-/Trailing Arm Bush	1.2 16V, 1.4 16V, 1.6, 1.6 16V, 1.7 DTI 16V, 1.7 TD, 1.8 16V, 2.0 16V, 2.0 DI, 2.0 DTI 16V		<b>F8-4090</b>		H1=50; H2=59; d=12; D1=36; D2=43
Control Arm-/Trailing Arm Bush	1.2 16V, 1.4 16V, 1.6, 1.6 16V, 1.7 DTI 16V, 1.7 TD, 1.8 16V, 2.0 16V, 2.0 DI, 2.0 DTI 16V		<b>F8-5130</b>		H=60; d=12; D=47
Engine Mounting	1.2 16V, 1.4 16V, 1.6, 1.6 16V, 1.8 16V	Code: KZ YU;	<b>F8-5365</b>		
Engine Mounting	1.6, 1.7 DTI 16V, 1.7 TD		<b>F8-5368</b>		
Engine Mounting	1.4 16V	X 14 XE	<b>F8-5444</b>		
Engine Mounting	1.6		<b>F8-5444</b>		
Engine Mounting	1.6 16V	X 16 XEL	<b>F8-5444</b>		
Top Strut Mounting	1.2 16V, 1.4 16V, 1.6, 1.6 16V, 1.7 CDTI 16V, 1.7 DTI 16V, 1.7 TD, 1.8 16V, 2.0 16V, 2.0 DI, 2.0 DTI 16V, 2.0 SRI Turbo, 2.2 16V	Bearing Type: Soft Version;	<b>F8-5448</b>		
Top Strut Mounting	1.2 16V, 1.4 16V, 1.6, 1.6 16V, 1.7 CDTI 16V, 1.7 DTI 16V, 1.7 TD, 1.8 16V, 2.0 16V, 2.0 DI, 2.0 DTI 16V, 2.0 SRI Turbo, 2.2 16V		<b>F8-5463</b>		
Belt Pulley, crankshaft	2.0 DI, 2.0 DTI 16V		<b>F8-5639</b>		
Rubber Buffer, suspension	1.4 16V, 1.6, 1.6 16V, 1.6 Dualfuel, 1.7 CDTI 16V, 1.7 DTI 16V, 1.8 16V, 1.8 16V Dualfuel, 2.0 16V, 2.0 DI, 2.0 DTI 16V, 2.0 SRI Turbo, 2.2 16V		<b>F8-5878</b>		H=62.5; d=24; D=50
Rubber Buffer, suspension	1.4 16V, 1.6, 1.6 16V, 1.6 Dualfuel, 1.7 CDTI 16V, 1.7 DTI 16V, 1.8 16V, 1.8 16V Dualfuel, 2.0 16V, 2.0 DI, 2.0 DTI 16V, 2.0 SRI Turbo, 2.2 16V		<b>F8-5913</b>		H=53; d=19; D=50
Engine Mounting	2.0 SRI Turbo, 2.2 16V		<b>F8-6217</b>		
Engine Mounting	2.0 DI, 2.0 DTI 16V		<b>F8-6494</b>		

<b>AK-735038</b>	<b>F5-1041</b>	<b>F5-1045</b>	<b>F5-1049</b>	<b>F5-1050</b>	<b>F8-4090</b>	<b>F8-5130</b>
Ref.Nr.: 344417	Ref.Nr.: 77364723	Ref.Nr.: 77362721	Ref.Nr.: 1204366	Ref.Nr.: 1204412	Ref.Nr.: 4566899	Ref.Nr.: 352365
<b>F8-5365</b>	<b>F8-5368</b>	<b>F8-5444</b>	<b>F8-5448</b>	<b>F8-5463</b>	<b>F8-5639</b>	<b>F8-5878</b>
Ref.Nr.: 5684045	Ref.Nr.: 0684692	Ref.Nr.: 90473852	Ref.Nr.: 0344523	Ref.Nr.: 0344525	Ref.Nr.: 0614411	Ref.Nr.: 0344417
<b>F8-5913</b>	<b>F8-6217</b>	<b>F8-6494</b>	<b>F8-6517</b>	<b>G9-593</b>	<b>G9-594</b>	<b>M-822900</b>
Ref.Nr.: 0344421	Ref.Nr.: 684168	Ref.Nr.: 0 684 697	Ref.Nr.: 90468618	Ref.Nr.: 90288232	Ref.Nr.: 90268463	Ref.Nr.: 90421747

Article Description



Article Nr.

Fitting Position



**ASTRA Mk IV (G) Hatchback**

02/1998 → 05/2005

Rubber Buffer, suspension	1.2 16V, 1.4 16V, 1.6, 1.6 16V, 1.6 Dualfuel, 1.7 CDTI 16V, 1.7 DTI 16V, 1.7 TD, 1.8 16V, 1.8 16V Dualfuel, 2.0, 2.0 16V, 2.0 DI, 2.0 DTI 16V, 2.0 SRI Turbo, 2.2 16V		<b>F8-6517</b>		
Mounting, axle beam	1.2 16V, 1.4 16V, 1.6, 1.6 16V, 1.6 Dualfuel, 1.7 CDTI 16V, 1.7 DTI 16V, 1.7 TD, 1.8 16V, 1.8 16V Dualfuel, 2.0, 2.0 16V, 2.0 DI, 2.0 DTI 16V, 2.0 SRI Turbo, 2.2 16V		<b>F8-6733</b>		d=14; L=35; D1=46; D2=38.4
Mounting, axle beam	1.2 16V, 1.4 16V, 1.6, 1.6 16V, 1.6 Dualfuel, 1.7 CDTI 16V, 1.7 DTI 16V, 1.7 TD, 1.8 16V, 1.8 16V Dualfuel, 2.0, 2.0 16V, 2.0 DI, 2.0 DTI 16V, 2.0 SRI Turbo, 2.2 16V		<b>F8-6734</b>		H=35.2; d=14.2; D1=45.9; D2=35.2
Engine Mounting	1.4 16V, 1.6, 1.6 16V, 1.6 Dualfuel, 1.8 16V, 1.8 16V Dualfuel	Yellow;	<b>F8-6755</b>		
Engine Mounting	1.7 CDTI 16V, 1.7 DTI 16V, 1.7 TD	Yellow	<b>F8-6755</b>		
Engine Mounting	1.4 16V	Z 14 XE;	<b>F8-6835</b>		
Engine Mounting	1.6 16V	X 16 XEL, Z 16 XE;	<b>F8-6835</b>		
Engine Mounting	1.6 Dualfuel, 1.8 16V, 1.8 16V Dualfuel		<b>F8-6835</b>		
Engine Mounting	1.7 CDTI 16V, 1.7 DTI 16V		<b>F8-6836</b>		
Engine Mounting	2.0 DI	ch.32000001, 35000001, 36000001, 38000001, 3B000001, 3H000001, 4G000001→	<b>F8-6836</b>		
Engine Mounting	2.0 DTI 16V	ch.32000001, 35000001, 36000001, 38000001, 3B000001, 3H000001, 4G000001→;  Y 20 DTH	<b>F8-6836</b>		
Engine Mounting	2.2 16V		<b>F8-6974</b>		
Belt Pulley, crankshaft	1.7 CDTI 16V, 1.7 DTI 16V	Number of Ribs: 6	<b>F8-7089</b>		Belt Pulley Ø [mm]=141; Mounting points diam.[mm]=48; W=27.5
Rubber Buffer, suspension	1.2 16V, 1.4 16V, 1.6, 1.6 16V, 1.6 Dualfuel, 1.7 CDTI 16V, 1.7 DTI 16V, 1.7 TD, 1.8 16V, 1.8 16V Dualfuel, 2.0, 2.0 16V, 2.0 DI, 2.0 DTI 16V, 2.0 SRI Turbo, 2.2 16V		<b>F8-7847</b>		
Engine Mounting	1.4 16V	X 14 XE;	<b>F8-8071</b>		
Engine Mounting	1.4 16V	Z 14 XE;	<b>F8-8071</b>		
Engine Mounting	1.6	X 16 SZR;	<b>F8-8071</b>		
Engine Mounting	1.6, 1.6 16V, 1.6 Dualfuel, 1.8 16V, 1.8 16V Dualfuel		<b>F8-8071</b>		
Engine Mounting	2.0 DI, 2.0 DTI 16V, 2.0 SRI Turbo, 2.2 16V		<b>F8-8137</b>		
Engine Mounting	1.2 16V, 1.4 16V, 1.6, 1.6 16V, 1.7 DTI 16V, 1.7 TD, 1.8 16V, 2.0 16V, 2.0 SRI Turbo, 2.2 16V		<b>F8-8142</b>		
Engine Mounting	2.0 16V, 2.0 DI, 2.0 DTI 16V		<b>F8-8155</b>		
Engine Mounting	1.2 16V, 1.4 16V, 1.6, 1.6 16V, 1.8 16V		<b>F8-8195</b>		

<b>F5-1050</b>	<b>F8-6517</b>	<b>F8-6733</b>	<b>F8-6734</b>	<b>F8-6755</b>	<b>F8-6835</b>	<b>F8-6836</b>
Ref.Nr.: 1204412	Ref.Nr.: 90468618	Ref.Nr.: 13107328	Ref.Nr.: 302275	Ref.Nr.: 90575457	Ref.Nr.: 684694	Ref.Nr.: 24427298
<b>F8-6974</b>	<b>F8-7089</b>	<b>F8-7847</b>	<b>F8-8071</b>	<b>F8-8137</b>	<b>F8-8142</b>	<b>F8-8155</b>
Ref.Nr.: 684249	Ref.Nr.: 5614444	Ref.Nr.: 90576351	Ref.Nr.: 684693	Ref.Nr.: 682502	Ref.Nr.: 90538582	Ref.Nr.: 5684048
<b>F8-8195</b>						
Ref.Nr.: 5684051						

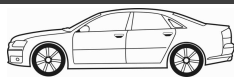
**Article Description****Article Nr.****Fitting Position****ASTRA Mk IV (G) Convertible** 03/2001 → 10/2005

Alternator Freewheel Clutch	1.6 16V, 1.8 16V		<b>F5-1050</b>		
Top Strut Mounting	1.6 16V, 1.8 16V, 2.0 Turbo, 2.2 16V	Bearing Type: Soft Version;	<b>F8-5448</b>		
Top Strut Mounting	1.6 16V, 1.8 16V, 2.0 Turbo, 2.2 16V		<b>F8-5463</b>		
Rubber Buffer, suspension	1.6 16V, 1.8 16V, 2.0 Turbo, 2.2 16V		<b>F8-5878</b>		H=62.5; d=24; D=50
Rubber Buffer, suspension	1.6 16V, 1.8 16V, 2.0 Turbo, 2.2 16V		<b>F8-5913</b>		H=53; d=19; D=50
Engine Mounting	2.0 Turbo, 2.2 16V		<b>F8-6217</b>		
Rubber Buffer, suspension	1.6 16V, 1.8 16V, 2.0, 2.0 Turbo, 2.2 16V		<b>F8-6517</b>		
Mounting, axle beam	1.6 16V, 1.8 16V, 2.0, 2.0 Turbo, 2.2 16V		<b>F8-6733</b>		d=14; L=35; D1=46; D2=38.4
Mounting, axle beam	1.6 16V, 1.8 16V, 2.0, 2.0 Turbo, 2.2 16V		<b>F8-6734</b>		H=35.2; d=14.2; D1=45.9; D2=35.2
Engine Mounting	1.6 16V, 1.8 16V	Yellow;	<b>F8-6755</b>		
Engine Mounting	1.6 16V, 1.8 16V		<b>F8-6835</b>		
Engine Mounting	2.2 16V		<b>F8-6974</b>		
Rubber Buffer, suspension	1.6 16V, 1.8 16V, 2.0, 2.0 Turbo, 2.2 16V		<b>F8-7847</b>		
Engine Mounting	1.6 16V, 1.8 16V		<b>F8-8071</b>		
Engine Mounting	2.0 Turbo, 2.2 16V		<b>F8-8137</b>		
Engine Mounting	1.6 16V, 1.8 16V, 2.0 Turbo, 2.2 16V		<b>F8-8142</b>		
Engine Mounting	1.6 16V, 1.8 16V		<b>F8-8195</b>		

**ASTRA Mk IV (G) Coupe (F67)** 03/2000 → 08/2005

Alternator Freewheel Clutch	1.8 16V, 1.8 16V Dualfuel		<b>F5-1050</b>		
Control Arm-/Trailing Arm Bush	1.8 16V, 2.0 16V Turbo, 2.2 16V		<b>F8-4090</b>		H1=50; H2=59; d=12; D1=36; D2=43
Control Arm-/Trailing Arm Bush	1.8 16V, 2.0 16V Turbo, 2.2 16V		<b>F8-5130</b>		H=60; d=12; D=47
Top Strut Mounting	1.8 16V, 2.0 16V Turbo, 2.2 16V	Bearing Type: Soft Version;	<b>F8-5448</b>		
Top Strut Mounting	1.8 16V, 2.0 16V Turbo, 2.2 16V		<b>F8-5463</b>		
Rubber Buffer, suspension	1.8 16V, 1.8 16V Dualfuel, 2.0 16V Turbo, 2.2 16V		<b>F8-5878</b>		H=62.5; d=24; D=50
Rubber Buffer, suspension	1.8 16V, 1.8 16V Dualfuel, 2.0 16V Turbo, 2.2 16V		<b>F8-5913</b>		H=53; d=19; D=50
Engine Mounting	2.0 16V Turbo, 2.2 16V		<b>F8-6217</b>		
Rubber Buffer, suspension	1.8 16V, 1.8 16V Dualfuel, 2.0, 2.0 16V Turbo, 2.2 16V		<b>F8-6517</b>		
Mounting, axle beam	1.8 16V, 1.8 16V Dualfuel, 2.0, 2.0 16V Turbo, 2.2 16V		<b>F8-6733</b>		d=14; L=35; D1=46; D2=38.4
Mounting, axle beam	1.8 16V, 1.8 16V Dualfuel, 2.0, 2.0 16V Turbo, 2.2 16V		<b>F8-6734</b>		H=35.2; d=14.2; D1=45.9; D2=35.2
Engine Mounting	1.8 16V, 1.8 16V Dualfuel	Yellow;	<b>F8-6755</b>		
Engine Mounting	1.8 16V		<b>F8-6835</b>		
Engine Mounting	1.8 16V, 1.8 16V Dualfuel		<b>F8-6835</b>		

<b>F5-1050</b>	<b>F8-4090</b>	<b>F8-5130</b>	<b>F8-5448</b>	<b>F8-5463</b>	<b>F8-5878</b>	<b>F8-5913</b>
Ref.Nr.: 1204412	Ref.Nr.: 4566899	Ref.Nr.: 352365	Ref.Nr.: 0344523	Ref.Nr.: 0344525	Ref.Nr.: 0344417	Ref.Nr.: 0344421
<b>F8-6217</b>	<b>F8-6517</b>	<b>F8-6733</b>	<b>F8-6734</b>	<b>F8-6755</b>	<b>F8-6835</b>	<b>F8-6974</b>
Ref.Nr.: 684168	Ref.Nr.: 90468618	Ref.Nr.: 13107328	Ref.Nr.: 302275	Ref.Nr.: 90575457	Ref.Nr.: 684694	Ref.Nr.: 684249
<b>F8-7847</b>	<b>F8-8071</b>	<b>F8-8137</b>	<b>F8-8142</b>	<b>F8-8195</b>		
Ref.Nr.: 90576351	Ref.Nr.: 684693	Ref.Nr.: 682502	Ref.Nr.: 90538582	Ref.Nr.: 5684051		

Article Description



Article Nr.

Fitting Position



**ASTRA Mk IV (G) Coupe (F67)** 03/2000 → 08/2005

Engine Mounting	2.2 16V		<b>F8-6974</b>	
Rubber Buffer, suspension	1.8 16V, 1.8 16V Dualfuel, 2.0, 2.0 16V Turbo, 2.2 16V		<b>F8-7847</b>	
Engine Mounting	1.8 16V	X 18 XE1;	<b>F8-8071</b>	
Engine Mounting	1.8 16V, 1.8 16V Dualfuel		<b>F8-8071</b>	
Engine Mounting	2.0 16V Turbo, 2.2 16V		<b>F8-8137</b>	
Engine Mounting	1.8 16V, 2.0 16V Turbo, 2.2 16V		<b>F8-8142</b>	
Engine Mounting	1.8 16V		<b>F8-8195</b>	

**ASTRA Mk IV (G) Estate** 02/1998 → 05/2005

Rubber Buffer, suspension	1.2 16V, 1.4 16V, 1.6, 1.6 16V, 1.6 Dualfuel, 1.7 CDTI 16V, 1.7 DTI 16V, 1.7 TD, 1.8 16V, 1.8 16V Dualfuel, 2.0 16V, 2.0 DI, 2.0 DTI 16V, 2.2 16V		<b>AK-735038</b>	
Alternator Freewheel Clutch	1.2 16V, 1.4 16V		<b>F5-1041</b>	
Alternator Freewheel Clutch	1.2 16V, 1.4 16V		<b>F5-1045</b>	
Alternator Freewheel Clutch	1.7 CDTI 16V		<b>F5-1049</b>	
Alternator Freewheel Clutch	1.4 16V, 1.6, 1.6 16V, 1.6 Dualfuel, 1.8 16V, 2.0 16V		<b>F5-1050</b>	
Control Arm-/Trailing Arm Bush	1.2 16V, 1.4 16V, 1.6, 1.6 16V, 1.7 DTI 16V, 1.7 TD, 1.8 16V, 2.0 16V, 2.0 DI, 2.0 DTI 16V		<b>F8-4090</b>	H1=50; H2=59; d=12; D1=36; D2=43
Control Arm-/Trailing Arm Bush	1.2 16V, 1.4 16V, 1.6, 1.6 16V, 1.7 DTI 16V, 1.7 TD, 1.8 16V, 2.0 16V, 2.0 DI, 2.0 DTI 16V		<b>F8-5130</b>	H=60; d=12; D=47
Engine Mounting	1.2 16V, 1.4 16V, 1.6, 1.6 16V, 1.8 16V	Code: KZ YU;	<b>F8-5365</b>	
Engine Mounting	1.6, 1.7 DTI 16V, 1.7 TD		<b>F8-5368</b>	
Engine Mounting	1.4 16V	X 14 XE	<b>F8-5444</b>	
Engine Mounting	1.6		<b>F8-5444</b>	
Engine Mounting	1.6 16V	X 16 XEL	<b>F8-5444</b>	
Top Strut Mounting	1.2 16V, 1.4 16V, 1.6, 1.6 16V, 1.7 CDTI 16V, 1.7 DTI 16V, 1.7 TD, 1.8 16V, 2.0 16V, 2.0 DI, 2.0 DTI 16V, 2.2 16V	Bearing Type: Soft Version;	<b>F8-5448</b>	
Top Strut Mounting	1.2 16V, 1.4 16V, 1.6, 1.6 16V, 1.7 CDTI 16V, 1.7 DTI 16V, 1.7 TD, 1.8 16V, 2.0 16V, 2.0 DI, 2.0 DTI 16V, 2.2 16V		<b>F8-5463</b>	
Belt Pulley, crankshaft	2.0 DI, 2.0 DTI 16V		<b>F8-5639</b>	
Rubber Buffer, suspension	1.4 16V, 1.6, 1.6 16V, 1.6 Dualfuel, 1.7 CDTI 16V, 1.7 DTI 16V, 1.8 16V, 1.8 16V Dualfuel, 2.0 DI, 2.0 DTI 16V, 2.2 16V		<b>F8-5878</b>	H=62.5; d=24; D=50
Rubber Buffer, suspension	1.4 16V, 1.6, 1.6 16V, 1.6 Dualfuel, 1.7 CDTI 16V, 1.7 DTI 16V, 1.8 16V, 1.8 16V Dualfuel, 2.0 DI, 2.0 DTI 16V, 2.2 16V		<b>F8-5913</b>	H=53; d=19; D=50
Engine Mounting	2.2 16V		<b>F8-6217</b>	
Engine Mounting	2.0 DI, 2.0 DTI 16V		<b>F8-6494</b>	

<b>AK-735038</b>	<b>F5-1041</b>	<b>F5-1045</b>	<b>F5-1049</b>	<b>F5-1050</b>	<b>F8-4090</b>	<b>F8-5130</b>
Ref.Nr.: 344417	Ref.Nr.: 77364723	Ref.Nr.: 77362721	Ref.Nr.: 1204366	Ref.Nr.: 1204412	Ref.Nr.: 4566899	Ref.Nr.: 352365
<b>F8-5365</b>	<b>F8-5368</b>	<b>F8-5444</b>	<b>F8-5448</b>	<b>F8-5463</b>	<b>F8-5639</b>	<b>F8-5878</b>
Ref.Nr.: 5684045	Ref.Nr.: 0684692	Ref.Nr.: 90473852	Ref.Nr.: 0344523	Ref.Nr.: 0344525	Ref.Nr.: 0614411	Ref.Nr.: 0344417
<b>F8-5913</b>	<b>F8-6217</b>	<b>F8-6494</b>	<b>F8-6517</b>	<b>F8-6974</b>	<b>F8-7847</b>	<b>F8-8071</b>
Ref.Nr.: 0344421	Ref.Nr.: 684168	Ref.Nr.: 0 684 697	Ref.Nr.: 90468618	Ref.Nr.: 684249	Ref.Nr.: 90576351	Ref.Nr.: 684693

**Article Description****Article Nr.****Fitting Position****ASTRA Mk IV (G) Estate** **02/1998 → 05/2005**

Rubber Buffer, suspension	1.2 16V, 1.4 16V, 1.6, 1.6 16V, 1.6 Dualfuel, 1.7 CDTI 16V, 1.7 DTI 16V, 1.7 TD, 1.8 16V, 1.8 16V Dualfuel, 2.0 16V, 2.0 DI, 2.0 DTI 16V, 2.2 16V		<b>F8-6517</b>		
Mounting, axle beam	1.2 16V, 1.4 16V, 1.6, 1.6 16V, 1.6 Dualfuel, 1.7 CDTI 16V, 1.7 DTI 16V, 1.7 TD, 1.8 16V, 1.8 16V Dualfuel, 2.0 16V, 2.0 DI, 2.0 DTI 16V, 2.2 16V		<b>F8-6733</b>		d=14; L=35; D1=46; D2=38.4
Mounting, axle beam	1.2 16V, 1.4 16V, 1.6, 1.6 16V, 1.6 Dualfuel, 1.7 CDTI 16V, 1.7 DTI 16V, 1.7 TD, 1.8 16V, 1.8 16V Dualfuel, 2.0 16V, 2.0 DI, 2.0 DTI 16V, 2.2 16V		<b>F8-6734</b>		H=35.2; d=14.2; D1=45.9; D2=35.2
Engine Mounting	1.4 16V, 1.6, 1.6 16V, 1.6 Dualfuel, 1.8 16V, 1.8 16V Dualfuel	Yellow;	<b>F8-6755</b>		
Engine Mounting	1.7 CDTI 16V, 1.7 DTI 16V, 1.7 TD	Yellow	<b>F8-6755</b>		
Engine Mounting	1.4 16V	Z 14 XE;	<b>F8-6835</b>		
Engine Mounting	1.6 16V	X 16 XEL, Z 16 XE;	<b>F8-6835</b>		
Engine Mounting	1.6 Dualfuel, 1.8 16V, 1.8 16V Dualfuel		<b>F8-6835</b>		
Engine Mounting	1.7 CDTI 16V, 1.7 DTI 16V		<b>F8-6836</b>		
Engine Mounting	2.0 DI	ch.32000001, 35000001, 36000001, 38000001, 3B000001, 3H000001, 4G000001→	<b>F8-6836</b>		
Engine Mounting	2.0 DTI 16V	ch.32000001, 35000001, 36000001, 38000001, 3B000001, 3H000001, 4G000001→;  Y 20 DTH	<b>F8-6836</b>		
Engine Mounting	2.2 16V		<b>F8-6974</b>		
Belt Pulley, crankshaft	1.7 CDTI 16V, 1.7 DTI 16V	Number of Ribs: 6	<b>F8-7089</b>		Belt Pulley Ø [mm]=141; Mounting points diam.[mm]=48; W=27.5
Rubber Buffer, suspension	2.0 DI		<b>F8-7847</b>		
Engine Mounting	1.4 16V, 1.6, 1.6 16V, 1.6 Dualfuel, 1.8 16V, 1.8 16V Dualfuel		<b>F8-8071</b>		
Engine Mounting	2.0 DI, 2.0 DTI 16V, 2.2 16V		<b>F8-8137</b>		
Engine Mounting	1.2 16V, 1.4 16V, 1.6, 1.6 16V, 1.7 DTI 16V, 1.7 TD, 1.8 16V, 2.0 16V		<b>F8-8142</b>		
Engine Mounting	2.0 16V, 2.0 DI, 2.0 DTI 16V		<b>F8-8155</b>		
Engine Mounting	1.2 16V, 1.4 16V, 1.6, 1.6 16V, 1.8 16V		<b>F8-8195</b>		

**ASTRA Mk IV (G) Saloon** **02/1998 → 05/2005**

Rubber Buffer, suspension	1.2 16V, 1.4 16V, 1.6, 1.6 16V, 1.6 Dualfuel, 1.7 CDTI 16V, 1.7 DTI 16V, 1.7 TD, 1.8 16V, 1.8 16V Dualfuel, 2.0 16V, 2.0 DI, 2.0 DTI 16V, 2.2 16V		<b>AK-735038</b>		
Alternator Freewheel Clutch	1.2 16V, 1.4 16V		<b>F5-1041</b>		
Alternator Freewheel Clutch	1.2 16V, 1.4 16V		<b>F5-1045</b>		
Alternator Freewheel Clutch	1.7 CDTI 16V		<b>F5-1049</b>		

<b>AK-735038</b>	<b>F5-1041</b>	<b>F5-1045</b>	<b>F5-1049</b>	<b>F5-1050</b>	<b>F8-6517</b>	<b>F8-6733</b>
Ref.Nr.: 344417	Ref.Nr.: 77364723	Ref.Nr.: 77362721	Ref.Nr.: 1204366	Ref.Nr.: 1204412	Ref.Nr.: 90468618	Ref.Nr.: 13107328
<b>F8-6734</b>	<b>F8-6755</b>	<b>F8-6835</b>	<b>F8-6836</b>	<b>F8-6974</b>	<b>F8-7089</b>	<b>F8-7847</b>
Ref.Nr.: 302275	Ref.Nr.: 90575457	Ref.Nr.: 684694	Ref.Nr.: 24427298	Ref.Nr.: 684249	Ref.Nr.: 5614444	Ref.Nr.: 90576351
<b>F8-8071</b>	<b>F8-8137</b>	<b>F8-8142</b>	<b>F8-8155</b>	<b>F8-8195</b>		
Ref.Nr.: 684693	Ref.Nr.: 682502	Ref.Nr.: 90538582	Ref.Nr.: 5684048	Ref.Nr.: 5684051		

Article Description



Article Nr.

Fitting Position



## ASTRA Mk IV (G) Saloon

02/1998 → 05/2005

Alternator Freewheel Clutch	1.4 16V, 1.6, 1.6 16V, 1.6 Dualfuel, 1.8 16V, 1.8 16V Dualfuel, 2.0 16V		F5-1050		
Control Arm-/Trailing Arm Bush	1.2 16V, 1.4 16V, 1.6, 1.6 16V, 1.7 DTI 16V, 1.7 TD, 1.8 16V, 2.0 16V, 2.0 DI, 2.0 DTI 16V		F8-4090		H1=50; H2=59; d=12; D1=36; D2=43
Control Arm-/Trailing Arm Bush	1.2 16V, 1.4 16V, 1.6, 1.6 16V, 1.7 DTI 16V, 1.7 TD, 1.8 16V, 2.0 16V, 2.0 DI, 2.0 DTI 16V		F8-5130		H=60; d=12; D=47
Engine Mounting	1.2 16V, 1.4 16V, 1.6, 1.6 16V, 1.8 16V	Code: KZ YU;	F8-5365		
Engine Mounting	1.6, 1.7 DTI 16V		F8-5368		
Engine Mounting	1.4 16V	X 14 XE	F8-5444		
Engine Mounting	1.6, 1.6 16V		F8-5444		
Top Strut Mounting	1.2 16V, 1.4 16V, 1.6, 1.6 16V, 1.7 CDTI 16V, 1.7 DTI 16V, 1.8 16V, 2.0 16V, 2.0 DI, 2.0 DTI 16V, 2.2 16V	Bearing Type: Soft Version;	F8-5448		
Top Strut Mounting	1.2 16V, 1.4 16V, 1.6, 1.6 16V, 1.7 CDTI 16V, 1.7 DTI 16V, 1.8 16V, 2.0 16V, 2.0 DI, 2.0 DTI 16V, 2.2 16V	;	F8-5463		
Belt Pulley, crankshaft	2.0 DI, 2.0 DTI 16V		F8-5639		
Rubber Buffer, suspension	1.4 16V, 1.6, 1.6 16V, 1.6 Dualfuel, 1.7 CDTI 16V, 1.7 DTI 16V, 1.8 16V, 1.8 16V Dualfuel, 2.0 DI, 2.0 DTI 16V		F8-5878		H=62.5; d=24; D=50
Rubber Buffer, suspension	1.4 16V, 1.6, 1.6 16V, 1.6 Dualfuel, 1.7 CDTI 16V, 1.7 DTI 16V, 1.8 16V, 1.8 16V Dualfuel, 2.0 DI, 2.0 DTI 16V		F8-5913		H=53; d=19; D=50
Engine Mounting	2.0 DI, 2.0 DTI 16V		F8-6494		
Rubber Buffer, suspension	1.2 16V, 1.4 16V, 1.6, 1.6 16V, 1.6 Dualfuel, 1.7 CDTI 16V, 1.7 DTI 16V, 1.7 TD, 1.8 16V, 1.8 16V Dualfuel, 2.0 16V, 2.0 DI, 2.0 DTI 16V, 2.2 16V		F8-6517		
Mounting, axle beam	1.2 16V, 1.4 16V, 1.6, 1.6 16V, 1.6 Dualfuel, 1.7 CDTI 16V, 1.7 DTI 16V, 1.7 TD, 1.8 16V, 1.8 16V Dualfuel, 2.0 16V, 2.0 DI, 2.0 DTI 16V, 2.2 16V		F8-6733		d=14; L=35; D1=46; D2=38.4
Mounting, axle beam	1.2 16V, 1.4 16V, 1.6, 1.6 16V, 1.6 Dualfuel, 1.7 CDTI 16V, 1.7 DTI 16V, 1.7 TD, 1.8 16V, 1.8 16V Dualfuel, 2.0 16V, 2.0 DI, 2.0 DTI 16V, 2.2 16V		F8-6734		H=35.2; d=14.2; D1=45.9; D2=35.2
Engine Mounting	1.4 16V, 1.6, 1.6 16V, 1.6 Dualfuel, 1.8 16V, 1.8 16V Dualfuel	Yellow;	F8-6755		
Engine Mounting	1.7 CDTI 16V, 1.7 DTI 16V, 1.7 TD	Yellow	F8-6755		
Engine Mounting	1.4 16V	Z 14 XE;	F8-6835		
Engine Mounting	1.6 16V	Z 16 XE;	F8-6835		
Engine Mounting	1.6 Dualfuel, 1.8 16V, 1.8 16V Dualfuel		F8-6835		
Engine Mounting	1.7 CDTI 16V, 1.7 DTI 16V		F8-6836		
Engine Mounting	2.0 DI	ch.32000001, 35000001, 36000001, 38000001, 3B000001, 3H000001, 4G000001→	F8-6836		

<b>F5-1050</b>	<b>F8-4090</b>	<b>F8-5130</b>	<b>F8-5365</b>	<b>F8-5368</b>	<b>F8-5444</b>	<b>F8-5448</b>
Ref.Nr.: 1204412	Ref.Nr.: 4566899	Ref.Nr.: 352365	Ref.Nr.: 5684045	Ref.Nr.: 0684692	Ref.Nr.: 90473852	Ref.Nr.: 0344523
<b>F8-5463</b>	<b>F8-5639</b>	<b>F8-5878</b>	<b>F8-5913</b>	<b>F8-6494</b>	<b>F8-6517</b>	<b>F8-6733</b>
Ref.Nr.: 0344525	Ref.Nr.: 0614411	Ref.Nr.: 0344417	Ref.Nr.: 0344421	Ref.Nr.: 0 684 697	Ref.Nr.: 90468618	Ref.Nr.: 13107328
<b>F8-6734</b>	<b>F8-6755</b>	<b>F8-6835</b>	<b>F8-6836</b>			
Ref.Nr.: 302275	Ref.Nr.: 90575457	Ref.Nr.: 684694	Ref.Nr.: 24427298			



Article Description



Article Nr.

Fitting Position



## ASTRA Mk IV (G) Saloon 02/1998 → 05/2005

Engine Mounting	2.0 DTI 16V	ch.32000001, 35000001, 36000001, 38000001, 3B000001, 3H000001, 4G000001→;  Y 20 DTH	F8-6836		
Engine Mounting	2.2 16V		F8-6974		
Belt Pulley, crankshaft	1.7 CDTI 16V, 1.7 DTI 16V	Number of Ribs: 6	F8-7089		Belt Pulley Ø [mm]=141; Mounting points diam.[mm]=48; W=27.5
Rubber Buffer, suspension	1.2 16V, 1.4 16V, 1.6, 1.6 16V, 1.6 Dualfuel, 1.7 CDTI 16V, 1.7 DTI 16V, 1.7 TD, 1.8 16V, 1.8 16V Dualfuel, 2.0 16V, 2.0 DI, 2.0 DTI 16V, 2.2 16V, 2.2 DTI		F8-7847		
Engine Mounting	1.4 16V	Z 14 XE;	F8-8071		
Engine Mounting	1.6 16V	C 16 SEL;	F8-8071		
Engine Mounting	1.6 16V	Z 16 XE;	F8-8071		
Engine Mounting	1.6, 1.6 Dualfuel, 1.8 16V, 1.8 16V Dualfuel		F8-8071		
Engine Mounting	2.0 DI, 2.0 DTI 16V, 2.2 16V		F8-8137		
Engine Mounting	1.2 16V, 1.4 16V, 1.6, 1.6 16V, 1.7 DTI 16V, 1.7 TD, 1.8 16V, 2.0 16V		F8-8142		
Engine Mounting	2.0 16V, 2.0 DI, 2.0 DTI 16V		F8-8155		
Engine Mounting	1.2 16V, 1.4 16V, 1.6, 1.6 16V, 1.8 16V		F8-8195		

## ASTRA Mk V (H) Hatchback 01/2004 → 09/2009

Dust Cover Kit, shock absorber	1.3 CDTI, 1.4, 1.6, 1.7 CDTI, 1.8, 1.9 CDTI, 1.9 CDTI 16V, 2.0 Turbo		AK-735251		
Dust Cover Kit, shock absorber	1.3 CDTI, 1.4, 1.6, 1.7 CDTI, 1.7 TD, 1.8, 1.9 CDTI, 1.9 CDTI 16V, 2.0 Turbo		AK-735252		
Alternator Freewheel Clutch	1.2, 1.3 CDTI, 1.4		F5-1041		
Alternator Freewheel Clutch	1.2, 1.3 CDTI, 1.4		F5-1045		
Alternator Freewheel Clutch	1.7 CDTI, 1.7 TD		F5-1049		
Alternator Freewheel Clutch	2.0 Turbo		F5-1100		
Alternator Freewheel Clutch	1.9 CDTI, 1.9 CDTI 16V		F5-1102		
Alternator Freewheel Clutch	1.9 CDTI, 1.9 CDTI 16V		F5-1123		
Top Strut Mounting	2.0 Turbo	Bearing Type: Soft Version;	F8-5448		
Top Strut Mounting	2.0 Turbo		F8-5463		
Engine Mounting	1.7 CDTI		F8-6657		
Mounting, axle beam	1.3 CDTI, 1.4, 1.6, 1.7 CDTI, 1.8, 1.9 CDTI, 1.9 CDTI 16V, 2.0 Turbo		F8-6733		d=14; L=35; D1=46; D2=38.4
Mounting, axle beam	1.3 CDTI, 1.4, 1.6, 1.7 CDTI, 1.8, 1.9 CDTI, 1.9 CDTI 16V, 2.0 Turbo		F8-6734		H=35.2; d=14.2; D1=45.9; D2=35.2
Engine Mounting	1.7 CDTI		F8-6836		
Engine Mounting	1.9 CDTI, 1.9 CDTI 16V		F8-6836		

<b>AK-735251</b>	<b>AK-735252</b>	<b>F5-1041</b>	<b>F5-1045</b>	<b>F5-1049</b>	<b>F5-1100</b>	<b>F5-1102</b>
Ref.Nr.: 344435	Ref.Nr.: 344416	Ref.Nr.: 77364723	Ref.Nr.: 77362721	Ref.Nr.: 1204366	Ref.Nr.: 1204393	Ref.Nr.: 1204151
<b>F5-1123</b>	<b>F8-5448</b>	<b>F8-5463</b>	<b>F8-6657</b>	<b>F8-6733</b>	<b>F8-6734</b>	<b>F8-6836</b>
Ref.Nr.: 9948513	Ref.Nr.: 0344523	Ref.Nr.: 0344525	Ref.Nr.: 5684134	Ref.Nr.: 13107328	Ref.Nr.: 302275	Ref.Nr.: 24427298
<b>F8-6974</b>	<b>F8-6975</b>	<b>F8-7089</b>	<b>F8-7847</b>	<b>F8-8071</b>	<b>F8-8137</b>	<b>F8-8142</b>
Ref.Nr.: 684249	Ref.Nr.: 24459803	Ref.Nr.: 5614444	Ref.Nr.: 90576351	Ref.Nr.: 684693	Ref.Nr.: 682502	Ref.Nr.: 90538582

Article Description



Article Nr.

Fitting Position



## ASTRA Mk V (H) Hatchback

01/2004 → 09/2009

Engine Mounting	1.4, 1.6	Code: KZ JE	<b>F8-6975</b>		
Engine Mounting	1.8	Code: KZ JE; Transmission Type: Easytronic	<b>F8-6975</b>		
Engine Mounting	1.8	Code: KZ JE;	<b>F8-6975</b>		
Engine Mounting	1.3 CDTi, 1.4, 1.6, 1.8	Code: KZ KD	<b>F8-6980</b>		
Engine Mounting	1.7 CDTi	Code: KZ KA;	<b>F8-6984</b>		
Engine Mounting	1.9 CDTi, 1.9 CDTi 16V	Code: KZ KA;	<b>F8-6984</b>		
Anti-Friction Bearing	1.3 CDTi, 1.4, 1.6, 1.7 CDTi, 1.7 TD, 1.8, 1.9 CDTi, 1.9 CDTi 16V, 2.0 Turbo		<b>F8-7172</b>		
Top Strut Mounting	1.3 CDTi, 1.4, 1.6, 1.7 CDTi, 1.7 TD, 1.8, 1.9 CDTi, 1.9 CDTi 16V, 2.0 Turbo	Additionally required articles: F8-7625;	<b>F8-7327</b>		
Top Strut Mounting	1.3 CDTi, 1.4, 1.6, 1.7 CDTi, 1.7 TD, 1.8, 1.9 CDTi, 1.9 CDTi 16V, 2.0 Turbo		<b>F8-7328</b>		
Top Strut Mounting	1.3 CDTi, 1.4, 1.6, 1.7 CDTi, 1.7 TD, 1.8, 1.9 CDTi, 1.9 CDTi 16V, 2.0 Turbo		<b>F8-7328S</b>		
Mounting Kit, shock absorber	1.2, 1.3 CDTi, 1.4, 1.6, 1.7 CDTi, 1.7 TD, 1.8, 1.9 CDTi, 1.9 CDTi 16V, 2.0 Turbo	for article nr: A-3246GL & A-3246GR, F8-7327	<b>F8-7625</b>		
Rubber Buffer, suspension	1.2, 1.3 CDTi, 1.4, 1.6, 1.7 CDTi, 1.8, 1.9 CDTi, 2.0 Turbo	ch.52000001, 55000001, 58000001, 8B000001→;	<b>F8-7662</b>		H=40
Protective Cap/Bellow, shock absorber	1.2, 1.3 CDTi, 1.4, 1.6, 1.6 Turbo, 1.7 CDTi, 1.8, 1.9 CDTi, 1.9 CDTi 16V, 2.0 Turbo		<b>F8-7663</b>		H=205
Rubber Buffer, suspension	1.2, 1.3 CDTi, 1.4, 1.6, 1.7 CDTi, 1.8, 1.9 CDTi, 2.0 Turbo	ch.→4299999, 4599999, 4899999;	<b>F8-7699</b>		H=50
Rubber Buffer, suspension	1.2, 1.3 CDTi, 1.4, 1.6, 1.7 CDTi, 1.8, 1.9 CDTi, 2.0 Turbo	ch.52000001, 55000001, 58000001→;	<b>F8-7699</b>		H=50
Rubber Buffer, suspension	1.2, 1.3 CDTi, 1.4, 1.6, 1.7 CDTi, 1.8, 1.9 CDTi, 1.9 CDTi 16V, 2.0 Turbo		<b>F8-7847</b>		
Belt Pulley, crankshaft	1.7 CDTi	Number of Ribs: 5; Parameter: 6PK	<b>F8-7872</b>		Belt Pulley Ø [mm]=149; H1=22; H2=32
Mounting, axle beam	1.2, 1.3 CDTi, 1.4, 1.6, 1.6 Turbo, 1.7 CDTi, 1.8, 1.9 CDTi, 1.9 CDTi 16V, 2.0 Turbo		<b>F8-7944</b>		d=13
Mounting, axle beam	1.8		<b>F8-7944</b>		d=13
Engine Mounting	1.8		<b>F8-8071</b>		
Engine Mounting	1.4, 1.6, 1.7 CDTi, 1.8, 1.9 CDTi, 1.9 CDTi 16V, 2.0 Turbo		<b>F8-8137</b>		
Engine Mounting	1.3 CDTi, 1.4, 1.6, 1.8		<b>F8-8142</b>		

## ASTRA Mk V (H) Estate

08/2004 → 10/2010

Dust Cover Kit, shock absorber	1.3 CDTi, 1.4, 1.6, 1.7 CDTi, 1.8, 1.9 CDTi, 2.0 Turbo		<b>AK-735251</b>		
Dust Cover Kit, shock absorber	1.3 CDTi, 1.4, 1.6, 1.7 CDTi, 1.7 TD, 1.8, 1.9 CDTi, 2.0 Turbo		<b>AK-735252</b>		
Alternator Freewheel Clutch	1.2, 1.3 CDTi, 1.4		<b>F5-1041</b>		
Alternator Freewheel Clutch	1.2, 1.3 CDTi, 1.4		<b>F5-1045</b>		

<b>AK-735251</b>	<b>AK-735252</b>	<b>F5-1041</b>	<b>F5-1045</b>	<b>F5-1049</b>	<b>F8-6975</b>	<b>F8-6980</b>
Ref.Nr.: 344435	Ref.Nr.: 344416	Ref.Nr.: 77364723	Ref.Nr.: 77362721	Ref.Nr.: 1204366	Ref.Nr.: 24459803	Ref.Nr.: 13125637
<b>F8-6984</b>	<b>F8-7172</b>	<b>F8-7327</b>	<b>F8-7328</b>	<b>F8-7328S</b>	<b>F8-7625</b>	<b>F8-7662</b>
Ref.Nr.: 13159997	Ref.Nr.: 9191181	Ref.Nr.: 13186960	Ref.Nr.: 13270705	Ref.Nr.: 344625	Ref.Nr.: 24402155	Ref.Nr.: 0344956
<b>F8-7663</b>	<b>F8-7699</b>	<b>F8-7847</b>	<b>F8-7872</b>	<b>F8-7944</b>	<b>F8-8071</b>	<b>F8-8137</b>
Ref.Nr.: 344435	Ref.Nr.: 13117280	Ref.Nr.: 90576351	Ref.Nr.: 614758	Ref.Nr.: 402 952	Ref.Nr.: 684693	Ref.Nr.: 682502



**Article Description****Article Nr.****Fitting Position**

<b>ASTRA Mk V (H) Estate</b>				<b>08/2004 → 10/2010</b>	
Alternator Freewheel Clutch	1.7 CDTi, 1.7 TD		<b>F5-1049</b>		
Alternator Freewheel Clutch	2.0 Turbo		<b>F5-1100</b>		
Alternator Freewheel Clutch	1.9 CDTi		<b>F5-1102</b>		
Alternator Freewheel Clutch	1.9 CDTi		<b>F5-1123</b>		
Top Strut Mounting	2.0 Turbo	Bearing Type: Soft Version;	<b>F8-5448</b>	⊕ ⊕	
Top Strut Mounting	2.0 Turbo	;	<b>F8-5463</b>	⊕ ⊕	
Mounting, axle beam	1.3 CDTi, 1.4, 1.6, 1.7 CDTi, 1.8, 1.9 CDTi, 2.0 Turbo		<b>F8-6733</b>	⊕ ⊕ ⊕	d=14; L=35; D1=46; D2=38.4
Mounting, axle beam	1.3 CDTi, 1.4, 1.6, 1.7 CDTi, 1.8, 1.9 CDTi, 2.0 Turbo		<b>F8-6734</b>	⊕ ⊕ ⊕	H=35.2; d=14.2; D1=45.9; D2=35.2
Engine Mounting	1.7 CDTi		<b>F8-6836</b>	⊕	
Engine Mounting	1.9 CDTi		<b>F8-6836</b>	⊕	
Engine Mounting	1.4, 1.6	Code: KZ JE	<b>F8-6975</b>		
Engine Mounting	1.8	Code: KZ JE;	<b>F8-6975</b>		
Engine Mounting	1.3 CDTi, 1.4, 1.6, 1.8	Code: KZ KD	<b>F8-6980</b>	⊕	
Engine Mounting	1.7 CDTi	Code: KZ KA;	<b>F8-6984</b>	⊕	
Engine Mounting	1.7 CDTi	Code: KZ KA;  Z 17 DTJ;	<b>F8-6984</b>	⊕	
Engine Mounting	1.9 CDTi	Code: KZ KA;	<b>F8-6984</b>	⊕	
Anti-Friction Bearing	1.3 CDTi, 1.4, 1.6, 1.7 CDTi, 1.7 TD, 1.8, 1.9 CDTi, 2.0 Turbo		<b>F8-7172</b>	⊕ ⊕ ⊕	
Top Strut Mounting	1.3 CDTi, 1.4, 1.6, 1.7 CDTi, 1.7 TD, 1.8, 1.9 CDTi, 2.0 Turbo	Additionally required articles: F8-7625;	<b>F8-7327</b>	⊕ ⊕ ⊕	
Top Strut Mounting	1.3 CDTi, 1.4, 1.6, 1.7 CDTi, 1.7 TD, 1.8, 1.9 CDTi, 2.0 Turbo		<b>F8-7328</b>	⊕ ⊕ ⊕	
Top Strut Mounting	1.3 CDTi, 1.4, 1.6, 1.7 CDTi, 1.7 TD, 1.8, 1.9 CDTi, 2.0 Turbo		<b>F8-7328S</b>	⊕ ⊕ ⊕	
Mounting Kit, shock absorber	1.2, 1.3 CDTi, 1.4, 1.6, 1.7 CDTi, 1.7 TD, 1.8, 1.9 CDTi, 2.0 Turbo	for article nr: A-3246GL & A-3246GR, F8-7327	<b>F8-7625</b>	⊕ ⊕ ⊕	
Rubber Buffer, suspension	1.3 CDTi, 1.4, 1.6, 1.7 CDTi, 1.8, 1.9 CDTi, 2.0 Turbo	ch.52000001, 55000001, 58000001, 8B000001→;	<b>F8-7662</b>	⊕ ⊕ ⊕	H=40
Protective Cap/Bellow, shock absorber	1.3 CDTi, 1.4, 1.6, 1.7 CDTi, 1.8, 1.9 CDTi, 2.0 Turbo		<b>F8-7663</b>	⊕ ⊕ ⊕	H=205
Rubber Buffer, suspension	1.3 CDTi, 1.4, 1.6, 1.7 CDTi, 1.8, 1.9 CDTi, 2.0 Turbo	ch.→4299999, 4599999, 4899999; ;	<b>F8-7699</b>	⊕ ⊕ ⊕	H=50
Rubber Buffer, suspension	1.3 CDTi, 1.4, 1.6, 1.7 CDTi, 1.8, 1.9 CDTi, 2.0 Turbo	ch.52000001, 55000001, 58000001→;	<b>F8-7699</b>	⊕ ⊕ ⊕	H=50
Rubber Buffer, suspension	1.4	ch.→4299999, 4599999, 4899999	<b>F8-7699</b>	⊕ ⊕ ⊕	H=50
Rubber Buffer, suspension	1.4	ch.52000001, 55000001, 58000001, 8B000001→;	<b>F8-7699</b>	⊕ ⊕ ⊕	H=50
Rubber Buffer, suspension	1.8	ch.→4299999, 4599999, 4899999;  Z 18 XER	<b>F8-7699</b>	⊕ ⊕ ⊕	H=50

<b>F5-1049</b>	<b>F5-1100</b>	<b>F5-1102</b>	<b>F5-1123</b>	<b>F8-5448</b>	<b>F8-5463</b>	<b>F8-6733</b>
Ref.Nr.: 1204366	Ref.Nr.: 1204393	Ref.Nr.: 1204151	Ref.Nr.: 9948513	Ref.Nr.: 0344523	Ref.Nr.: 0344525	Ref.Nr.: 13107328
<b>F8-6734</b>	<b>F8-6836</b>	<b>F8-6975</b>	<b>F8-6980</b>	<b>F8-6984</b>	<b>F8-7172</b>	<b>F8-7327</b>
Ref.Nr.: 302275	Ref.Nr.: 24427298	Ref.Nr.: 24459803	Ref.Nr.: 13125637	Ref.Nr.: 13159997	Ref.Nr.: 9191181	Ref.Nr.: 13186960
<b>F8-7328</b>	<b>F8-7328S</b>	<b>F8-7625</b>	<b>F8-7662</b>	<b>F8-7663</b>	<b>F8-7699</b>	
Ref.Nr.: 13270705	Ref.Nr.: 344625	Ref.Nr.: 24402155	Ref.Nr.: 0344956	Ref.Nr.: 344435	Ref.Nr.: 13117280	

Article Description



Article Nr.

Fitting Position



### ASTRA Mk V (H) Estate

08/2004 → 10/2010

Rubber Buffer, suspension	1.8	ch.52000001, 55000001, 58000001, 8B000001→;  Z 18 XER;	F8-7699		H=50
Rubber Buffer, suspension	1.2, 1.3 CDTi, 1.4, 1.6, 1.7 CDTi, 1.8, 1.9 CDTi, 2.0 Turbo		F8-7847		
Belt Pulley, crankshaft	1.7 CDTi	Number of Ribs: 5; Parameter: 6PK	F8-7872		Belt Pulley Ø [mm]=149; H1=22; H2=32
Mounting, axle beam	1.3 CDTi, 1.4, 1.6, 1.7 CDTi, 1.8, 1.9 CDTi, 2.0 Turbo		F8-7944		d=13
Mounting, axle beam	1.6	Z 16 XER	F8-7944		d=13
Mounting, axle beam	1.7 CDTi	Z 17 DTJ	F8-7944		d=13
Mounting, axle beam	1.8	Z 18 XER	F8-7944		d=13
Engine Mounting	1.8		F8-8071		
Engine Mounting	1.4, 1.6, 1.7 CDTi, 1.8, 1.9 CDTi, 2.0 Turbo		F8-8137		
Engine Mounting	1.3 CDTi, 1.4, 1.6, 1.8		F8-8142		

### ASTRA Mk V (H) Sport Hatch

02/2005 → 11/2010

Dust Cover Kit, shock absorber	1.3 CDTi, 1.4 i 16V, 1.6, 1.6 i 16V, 1.7 CDTi, 1.8, 1.8 i 16V, 1.9 CDTi, 2.0 Turbo, 2.0 VXR		AK-735251		
Dust Cover Kit, shock absorber	1.3 CDTi, 1.6, 1.7 CDTi, 1.8, 1.8 i 16V, 1.9 CDTi, 2.0 Turbo, 2.0 VXR		AK-735252		
Alternator Freewheel Clutch	1.3 CDTi, 1.4, 1.4 i 16V		F5-1041		
Alternator Freewheel Clutch	1.3 CDTi, 1.4, 1.4 i 16V		F5-1045		
Alternator Freewheel Clutch	1.7 CDTi		F5-1049		
Alternator Freewheel Clutch	1.8		F5-1050		
Alternator Freewheel Clutch	2.0 Turbo, 2.0 VXR		F5-1100		
Alternator Freewheel Clutch	1.9 CDTi		F5-1102		
Alternator Freewheel Clutch	1.9 CDTi		F5-1123		
Mounting, axle beam	1.6, 1.7 CDTi, 1.8, 1.9 CDTi, 2.0 Turbo		F8-6733		d=14; L=35; D1=46; D2=38.4
Mounting, axle beam	1.6, 1.7 CDTi, 1.8, 1.9 CDTi, 2.0 Turbo		F8-6734		H=35.2; d=14.2; D1=45.9; D2=35.2
Engine Mounting	1.9 CDTi		F8-6836		
Engine Mounting	1.6	Code: KZ JE	F8-6975		
Engine Mounting	1.8	Code: KZ JE;	F8-6975		
Engine Mounting	1.3 CDTi, 1.6, 1.8	Code: KZ KD	F8-6980		
Engine Mounting	1.7 CDTi	Code: KZ KA;	F8-6984		
Engine Mounting	1.9 CDTi	Code: KZ KA;	F8-6984		
Anti-Friction Bearing	1.3 CDTi, 1.4 i 16V, 1.6, 1.6 i 16V, 1.7 CDTi, 1.8, 1.8 i 16V, 1.9 CDTi, 2.0 Turbo, 2.0 VXR		F8-7172		
Top Strut Mounting	1.3 CDTi, 1.4 i 16V, 1.6, 1.6 i 16V, 1.7 CDTi, 1.8, 1.8 i 16V, 1.9 CDTi, 2.0 Turbo, 2.0 VXR	Additionally required articles: F8-7625;	F8-7327		

<b>AK-735251</b>	<b>AK-735252</b>	<b>F5-1041</b>	<b>F5-1045</b>	<b>F5-1049</b>	<b>F5-1050</b>	<b>F5-1100</b>
Ref.Nr.: 344435	Ref.Nr.: 344416	Ref.Nr.: 77364723	Ref.Nr.: 77362721	Ref.Nr.: 1204366	Ref.Nr.: 1204412	Ref.Nr.: 1204393
<b>F5-1102</b>	<b>F5-1123</b>	<b>F8-6733</b>	<b>F8-6734</b>	<b>F8-6836</b>	<b>F8-6975</b>	<b>F8-6980</b>
Ref.Nr.: 1204151	Ref.Nr.: 9948513	Ref.Nr.: 13107328	Ref.Nr.: 302275	Ref.Nr.: 24427298	Ref.Nr.: 24459803	Ref.Nr.: 13125637
<b>F8-6984</b>	<b>F8-7172</b>	<b>F8-7327</b>	<b>F8-7328</b>	<b>F8-7699</b>	<b>F8-7847</b>	<b>F8-7872</b>
Ref.Nr.: 13159997	Ref.Nr.: 9191181	Ref.Nr.: 13186960	Ref.Nr.: 13270705	Ref.Nr.: 13117280	Ref.Nr.: 90576351	Ref.Nr.: 614758

**Article Description****Article Nr.****Fitting Position**

<b>ASTRA Mk V (H) Sport Hatch</b>		<b>02/2005 → 11/2010</b>	
Top Strut Mounting	1.3 CDTi, 1.4 i 16V, 1.6, 1.6 i 16V, 1.7 CDTi, 1.8, 1.8 i 16V, 1.9 CDTi, 2.0 Turbo, 2.0 VXR		<b>F8-7328</b>
Top Strut Mounting	1.3 CDTi, 1.4 i 16V, 1.6, 1.6 i 16V, 1.7 CDTi, 1.8, 1.8 i 16V, 1.9 CDTi, 2.0 Turbo, 2.0 VXR		<b>F8-7328S</b>
Mounting Kit, shock absorber	1.3 CDTi, 1.4, 1.4 i 16V, 1.6, 1.6 i 16V, 1.7 CDTi, 1.8, 1.8 i 16V, 1.9 CDTi, 2.0 Turbo, 2.0 VXR	for article nr: A-3246GL & A-3246GR, F8-7327	<b>F8-7625</b>
Rubber Buffer, suspension	1.4, 1.6, 1.7 CDTi, 1.8, 1.9 CDTi, 2.0 Turbo	ch.52000001, 55000001, 58000001, 8B000001→; <b>SP</b>	<b>F8-7662</b>
Protective Cap/Bellow, shock absorber	1.4, 1.6, 1.7 CDTi, 1.8, 1.9 CDTi, 2.0 Turbo		<b>F8-7663</b>
Rubber Buffer, suspension	1.4	ch.→4299999, 4599999, 4899999	<b>F8-7699</b>
Rubber Buffer, suspension	1.4	ch.52000001, 55000001, 58000001, 8B000001→; <b>SP</b>	<b>F8-7699</b>
Rubber Buffer, suspension	1.6, 1.7 CDTi, 1.8, 1.9 CDTi, 2.0 Turbo	ch.→4299999, 4599999, 4899999; <b>SR</b>	<b>F8-7699</b>
Rubber Buffer, suspension	1.6, 1.7 CDTi, 1.8, 1.9 CDTi, 2.0 Turbo	ch.52000001, 55000001, 58000001→; <b>SP</b>	<b>F8-7699</b>
Rubber Buffer, suspension	1.3 CDTi, 1.4, 1.4 i 16V, 1.6, 1.6 i 16V, 1.7 CDTi, 1.8, 1.8 i 16V, 1.9 CDTi, 2.0 Turbo, 2.0 VXR		<b>F8-7847</b>
Belt Pulley, crankshaft	1.7 CDTi	Number of Ribs: 5; Parameter: 6PK	<b>F8-7872</b>
Mounting, axle beam	1.6, 1.7 CDTi, 1.8, 1.9 CDTi, 2.0 Turbo		<b>F8-7944</b>
Engine Mounting	1.8		<b>F8-8071</b>
Engine Mounting	1.6, 1.7 CDTi, 1.8, 2.0 Turbo, 2.0 VXR		<b>F8-8137</b>
Engine Mounting	1.3 CDTi, 1.6, 1.8		<b>F8-8142</b>
<b>ASTRA TwinTop Mk V (H)</b>		<b>09/2005 → 11/2010</b>	
Dust Cover Kit, shock absorber	1.6, 1.6 i 16V, 1.8, 1.9 CDTi, 2.0, 2.0 Turbo	<b>ST</b>	<b>AK-735252</b>
Alternator Freewheel Clutch	2.0, 2.0 Turbo		<b>F5-1100</b>
Alternator Freewheel Clutch	1.9 CDTi		<b>F5-1102</b>
Alternator Freewheel Clutch	1.9 CDTi		<b>F5-1123</b>
Mounting, axle beam	1.6, 1.6 i 16V, 1.9 CDTi, 2.0, 2.0 Turbo		<b>F8-6733</b>
Mounting, axle beam	1.6, 1.6 i 16V, 1.9 CDTi, 2.0, 2.0 Turbo		<b>F8-6734</b>
Engine Mounting	1.6, 1.6 i 16V	Code: KZ JE	<b>F8-6975</b>
Engine Mounting	1.6, 1.6 i 16V	Code: KZ KD	<b>F8-6980</b>
Engine Mounting	1.9 CDTi	Code: KZ KA;	<b>F8-6984</b>
Anti-Friction Bearing	1.6, 1.6 i 16V, 1.8, 1.9 CDTi, 2.0, 2.0 Turbo		<b>F8-7172</b>
Mounting Kit, shock absorber	1.6, 1.6 i 16V, 1.8, 1.9 CDTi, 2.0, 2.0 Turbo	for article nr: A-3246GL & A-3246GR, F8-7327	<b>F8-7625</b>
Rubber Buffer, suspension	1.6, 1.6 i 16V, 1.9 CDTi, 2.0, 2.0 Turbo	ch.52000001, 55000001, 58000001→; <b>SP</b>	<b>F8-7662</b>

<b>AK-735252</b>	<b>F5-1100</b>	<b>F5-1102</b>	<b>F5-1123</b>	<b>F8-6733</b>	<b>F8-6734</b>	<b>F8-6975</b>
Ref.Nr.: 344416	Ref.Nr.: 1204393	Ref.Nr.: 1204151	Ref.Nr.: 9948513	Ref.Nr.: 13107328	Ref.Nr.: 302275	Ref.Nr.: 24459803
<b>F8-6980</b>	<b>F8-6984</b>	<b>F8-7172</b>	<b>F8-7328</b>	<b>F8-7328S</b>	<b>F8-7625</b>	<b>F8-7662</b>
Ref.Nr.: 13125637	Ref.Nr.: 13159997	Ref.Nr.: 9191181	Ref.Nr.: 13270705	Ref.Nr.: 344625	Ref.Nr.: 24402155	Ref.Nr.: 0344956
<b>F8-7663</b>	<b>F8-7699</b>	<b>F8-7847</b>	<b>F8-7872</b>	<b>F8-7944</b>	<b>F8-8071</b>	<b>F8-8137</b>
Ref.Nr.: 344435	Ref.Nr.: 13117280	Ref.Nr.: 90576351	Ref.Nr.: 614758	Ref.Nr.: 402 952	Ref.Nr.: 684693	Ref.Nr.: 682502

Article Description



Article Nr.

Fitting Position



<b>ASTRA TwinTop Mk V (H)</b>			<b>09/2005 → 11/2010</b>		
Rubber Buffer, suspension	1.8		<b>F8-7662</b>		H=40
Protective Cap/Bellow, shock absorber	1.6, 1.6 i 16V, 1.8, 1.9 CDTi, 2.0, 2.0 Turbo		<b>F8-7663</b>		H=205
Rubber Buffer, suspension	1.6, 1.6 i 16V, 1.9 CDTi, 2.0, 2.0 Turbo	ch.→4299999, 4599999, 4899999;	<b>F8-7699</b>		H=50
Rubber Buffer, suspension	1.6, 1.6 i 16V, 1.9 CDTi, 2.0, 2.0 Turbo	ch.52000001, 55000001, 58000001→;	<b>F8-7699</b>		H=50
Rubber Buffer, suspension	1.6, 1.6 i 16V, 1.8, 1.9 CDTi, 2.0, 2.0 Turbo		<b>F8-7847</b>		
Mounting, axle beam	1.6, 1.6 i 16V, 1.8, 1.9 CDTi, 2.0, 2.0 Turbo		<b>F8-7944</b>		d=13
Engine Mounting	1.6, 1.6 i 16V, 1.9 CDTi, 2.0, 2.0 Turbo		<b>F8-8137</b>		
Engine Mounting	1.6		<b>F8-8142</b>		
<b>ASTRA Mk VI (J)</b>			<b>12/2009 →</b>		
Top Strut Mounting	1.3 CDTi, 1.4, 1.4 Turbo, 1.6, 1.6 Turbo, 1.7 CDTi, 2.0 CDTi		<b>F8-7616</b>		H=49; D=114
Rubber Buffer, suspension	1.3 CDTi, 1.4, 1.4 Turbo, 1.6, 1.6 Turbo, 1.7 CDTi, 2.0 CDTi		<b>F8-7621</b>		H=270
Belt Pulley, crankshaft	1.7 CDTi	Number of Ribs: 5; Parameter: 6PK	<b>F8-7872</b>		Belt Pulley Ø [mm]=149; H1=22; H2=32
<b>ASTRA Mk VI (J) Saloon</b>			<b>06/2012 →</b>		
Top Strut Mounting	1.3 CDTi, 1.4, 1.4 Turbo, 1.6 Turbo, 1.7 CDTi		<b>F8-7616</b>		H=49; D=114
<b>ASTRA Mk VI (J) Estate</b>			<b>12/2009 →</b>		
Top Strut Mounting	1.3 CDTi, 1.4, 1.4 Turbo, 1.6, 1.6 Turbo, 1.7 CDTi, 2.0 CDTi		<b>F8-7616</b>		H=49; D=114
Belt Pulley, crankshaft	1.7 CDTi	Number of Ribs: 5; Parameter: 6PK	<b>F8-7872</b>		Belt Pulley Ø [mm]=149; H1=22; H2=32
<b>ASTRA GTC Mk VI (J)</b>			<b>10/2011 →</b>		
Top Strut Mounting	1.4, 1.6, 1.7 CDTi, 2.0 CDTi		<b>F8-7616</b>		H=49; D=114
<b>ASTRAVAN Mk III (F)</b>			<b>01/1991 → 08/1998</b>		
Engine Mounting	1.4 i		<b>F8-5372</b>		
Engine Mounting	1.6 i		<b>F8-5372</b>		
Engine Mounting	1.6 i		<b>F8-5436</b>		
Engine Mounting	1.4 i		<b>F8-5439</b>		
Engine Mounting	1.7 D, 1.7 TD		<b>F8-5439</b>		
Engine Mounting	1.4 i, 1.6 i		<b>F8-5444</b>		
Engine Mounting	1.6 i		<b>F8-5467</b>		
Engine Mounting	1.6 i		<b>F8-5467</b>		
Engine Mounting	1.4 i		<b>F8-5468</b>		
Engine Mounting	1.6 i		<b>F8-5468</b>		

<b>F8-5372</b>	<b>F8-5436</b>	<b>F8-5439</b>	<b>F8-5444</b>	<b>F8-5467</b>	<b>F8-5468</b>	<b>F8-7616</b>
Ref.Nr.: 90278345	Ref.Nr.: 0684641	Ref.Nr.: 684289	Ref.Nr.: 90473852	Ref.Nr.: 0684285	Ref.Nr.: 0684283	Ref.Nr.: 0344573
<b>F8-7621</b>	<b>F8-7662</b>	<b>F8-7663</b>	<b>F8-7699</b>	<b>F8-7847</b>	<b>F8-7872</b>	<b>F8-7944</b>
Ref.Nr.: 13251764	Ref.Nr.: 0344956	Ref.Nr.: 344435	Ref.Nr.: 13117280	Ref.Nr.: 90576351	Ref.Nr.: 614758	Ref.Nr.: 402 952
<b>F8-8137</b>	<b>F8-8142</b>					
Ref.Nr.: 682502	Ref.Nr.: 90538582					

**Article Description****Article Nr.****Fitting Position**

<b>ASTRAVAN Mk III (F)</b>			<b>01/1991 → 08/1998</b>		
Engine Mounting	1.7 D, 1.7 TD		<b>F8-5468</b>		
Rubber Buffer, suspension	1.6 i		<b>F8-5710</b>		H=46
Rubber Buffer, suspension	1.7 TD		<b>F8-5710</b>		H=46
Control Arm-/Trailing Arm Bush	All Models	ch.P2603823, P5000000, P8146890, PB000001→; ch.→R2587415, R5111734, R8145949, RB011797	<b>F8-5969</b>		H=58; d=16; D=60
Sleeve, control arm mounting	All Models		<b>F8-6656</b>		
Control Arm-/Trailing Arm Bush	All Models		<b>G9-593</b>		d=12; D1=39; D2=44
C.V. Boot	1.7 D	ch.N1000001, N2000001, N5000001→; ch.→N2733477, N5273484, P8202125	<b>M-822900</b>		
<b>ASTRAVAN Mk IV (G)</b>			<b>08/1998 → 08/2006</b>		
Rubber Buffer, suspension	1.6 i, 1.7 CDTI, 1.7 TD, 2.0 DI, 2.0 DTI		<b>AK-735038</b>		
Alternator Freewheel Clutch	1.7 CDTI		<b>F5-1049</b>		
Alternator Freewheel Clutch	1.6 i		<b>F5-1050</b>		
Engine Mounting	1.6 i, 1.7 DTI 16V, 1.7 TD		<b>F8-5368</b>		
Top Strut Mounting	1.6 i, 1.7 TD, 2.0 DI, 2.0 DTI	Bearing Type: Soft Version;	<b>F8-5448</b>		
Top Strut Mounting	1.6 i, 1.7 TD, 2.0 DI, 2.0 DTI		<b>F8-5463</b>		
Belt Pulley, crankshaft	2.0 DI, 2.0 DTI		<b>F8-5639</b>		
Rubber Buffer, suspension	1.6 i, 1.7 TD, 2.0 DI, 2.0 DTI		<b>F8-5878</b>		H=62.5; d=24; D=50
Rubber Buffer, suspension	1.6 i, 1.7 TD, 2.0 DI, 2.0 DTI		<b>F8-5913</b>		H=53; d=19; D=50
Engine Mounting	2.0 DI, 2.0 DTI		<b>F8-6494</b>		
Rubber Buffer, suspension	1.6 i, 1.7 CDTI, 1.7 TD, 2.0 DI, 2.0 DTI		<b>F8-6517</b>		
Engine Mounting	1.7 CDTI		<b>F8-6657</b>		
Mounting, axle beam	1.6 i, 1.7 CDTI, 1.7 DTI 16V, 1.7 TD, 2.0 DI, 2.0 DTI		<b>F8-6733</b>		d=14; L=35; D1=46; D2=38.4
Mounting, axle beam	1.6 i, 1.7 CDTI, 1.7 DTI 16V, 1.7 TD, 2.0 DI, 2.0 DTI		<b>F8-6734</b>		H=35.2; d=14.2; D1=45.9; D2=35.2
Engine Mounting	1.7 TD		<b>F8-6836</b>		
Belt Pulley, crankshaft	1.7 CDTI	ch.→38059700; Number of Ribs: 6	<b>F8-7089</b>		Belt Pulley Ø [mm]=141; Mounting points diam.[mm]=48; W=27.5
Rubber Buffer, suspension	1.7 CDTI	ch.52000001, 55000001, 58000001, 8B000001→;	<b>F8-7662</b>		H=40
Protective Cap/Bellow, shock absorber	1.7 CDTI		<b>F8-7663</b>		H=205
Rubber Buffer, suspension	1.7 CDTI	ch.→4299999, 4599999, 4899999;	<b>F8-7699</b>		H=50
Rubber Buffer, suspension	1.7 CDTI	ch.52000001, 55000001, 58000001→;	<b>F8-7699</b>		H=50

<b>AK-735038</b>	<b>F5-1049</b>	<b>F5-1050</b>	<b>F8-5368</b>	<b>F8-5448</b>	<b>F8-5463</b>	<b>F8-5468</b>
Ref.Nr.: 344417	Ref.Nr.: 1204366	Ref.Nr.: 1204412	Ref.Nr.: 0684692	Ref.Nr.: 0344523	Ref.Nr.: 0344525	Ref.Nr.: 0684283
<b>F8-5639</b>	<b>F8-5710</b>	<b>F8-5878</b>	<b>F8-5913</b>	<b>F8-5969</b>	<b>F8-6494</b>	<b>F8-6517</b>
Ref.Nr.: 0614411	Ref.Nr.: 0344402	Ref.Nr.: 0344417	Ref.Nr.: 0344421	Ref.Nr.: 352352	Ref.Nr.: 0 684 697	Ref.Nr.: 90468618
<b>F8-6656</b>	<b>F8-6657</b>	<b>F8-6733</b>	<b>F8-6734</b>	<b>F8-6836</b>	<b>F8-7089</b>	<b>F8-7662</b>
Ref.Nr.: 4246062	Ref.Nr.: 5684134	Ref.Nr.: 13107328	Ref.Nr.: 302275	Ref.Nr.: 24427298	Ref.Nr.: 5614444	Ref.Nr.: 0344956

Article Description



Article Nr.

Fitting Position



### ASTRAVAN Mk IV (G)

08/1998 → 08/2006

Rubber Buffer, suspension	1.6 i, 1.7 DTi 16V, 1.7 TD, 2.0 DI, 2.0 DTi		F8-7847		
Rubber Buffer, suspension	1.7 CDTi		F8-7847		
Mounting, axle beam	1.7 CDTi		F8-7944		d=13
Engine Mounting	1.6 i		F8-8071		
Engine Mounting	1.6 i	X 16 SZR;	F8-8071		
Engine Mounting	1.6 i, 1.7 TD, 2.0 DI		F8-8142		
Engine Mounting	1.6 i		F8-8195		

### ASTRAVAN Mk V (H)

03/2005 → 12/2013

Alternator Freewheel Clutch	1.3 CDTi		F5-1041		
Alternator Freewheel Clutch	1.3 CDTi		F5-1045		
Alternator Freewheel Clutch	1.7 CDTi		F5-1049		
Alternator Freewheel Clutch	1.9 CDTi		F5-1102		
Alternator Freewheel Clutch	1.9 CDTi		F5-1123		
Engine Mounting	1.7 CDTi		F8-6657		
Mounting, axle beam	1.6, 1.7 CDTi		F8-6733		d=14; L=35; D1=46; D2=38.4
Mounting, axle beam	1.6, 1.7 CDTi		F8-6734		H=35.2; d=14.2; D1=45.9; D2=35.2
Engine Mounting	1.9 CDTi	Code: KZ KA	F8-6984		
Mounting Kit, shock absorber	All Models	for article nr: A-3246GL & A-3246GR, F8-7327	F8-7625		
Rubber Buffer, suspension	1.3 CDTi, 1.4 i, 1.6, 1.9 CDTi	ch.52000001, 55000001, 58000001, 8B000001→;	F8-7662		H=40
Protective Cap/Bellow, shock absorber	1.3 CDTi, 1.4 i, 1.6, 1.7 CDTi, 1.9 CDTi		F8-7663		H=205
Rubber Buffer, suspension	1.3 CDTi, 1.4 i, 1.6, 1.9 CDTi	ch.→4299999, 4599999, 4899999;	F8-7699		H=50
Rubber Buffer, suspension	1.3 CDTi, 1.4 i, 1.6, 1.9 CDTi	ch.52000001, 55000001, 58000001→;	F8-7699		H=50
Rubber Buffer, suspension	1.7 CDTi	ch.→4299999, 4599999, 4899999;  A17DTJ	F8-7699		H=50
Rubber Buffer, suspension	1.7 CDTi	ch.52000001, 55000001, 58000001, 8B000001→;  A17DTJ;	F8-7699		H=50
Rubber Buffer, suspension	1.3 CDTi, 1.4 i, 1.6, 1.7 CDTi, 1.9 CDTi		F8-7847		
Rubber Buffer, suspension	1.7 CDTi		F8-7847		
Mounting, axle beam	1.6		F8-7944		d=13

### CALIBRA

06/1990 → 07/1997

Dust Cover Kit, shock absorber	All Models		AK-735003		
Anti-Friction Bearing	2.0 i 16V, 2.0 i 16V 4x4, 2.0 i Turbo 4x4		F8-3026		H=11; d1=16; d2=22; D=41

<b>AK-735003</b>	<b>F5-1041</b>	<b>F5-1045</b>	<b>F5-1049</b>	<b>F5-1102</b>	<b>F5-1123</b>	<b>F8-3026</b>
Ref.Nr.:	Ref.Nr.: 77364723	Ref.Nr.: 77362721	Ref.Nr.: 1204366	Ref.Nr.: 1204151	Ref.Nr.: 9948513	Ref.Nr.: 90425479
<b>F8-4099</b>	<b>F8-6657</b>	<b>F8-6733</b>	<b>F8-6734</b>	<b>F8-6984</b>	<b>F8-7625</b>	<b>F8-7662</b>
Ref.Nr.: 0423313	Ref.Nr.: 5684134	Ref.Nr.: 13107328	Ref.Nr.: 302275	Ref.Nr.: 13159997	Ref.Nr.: 24402155	Ref.Nr.: 0344956
<b>F8-7663</b>	<b>F8-7699</b>	<b>F8-7847</b>	<b>F8-7944</b>	<b>F8-8071</b>	<b>F8-8142</b>	<b>F8-8195</b>
Ref.Nr.: 344435	Ref.Nr.: 13117280	Ref.Nr.: 90576351	Ref.Nr.: 402 952	Ref.Nr.: 684693	Ref.Nr.: 90538582	Ref.Nr.: 5684051

**Article Description****Article Nr.****Fitting Position**

<b>CALIBRA</b>				<b>06/1990 → 07/1997</b>	
Control Arm-/Trailing Arm Bush	2.0 i, 2.0 i 16V, 2.0 i 16V 4x4, 2.0 i 4x4, 2.5 i V6		<b>F8-4099</b>		H=70; d=12; D1=46; D2=49
Control Arm-/Trailing Arm Bush	All Models		<b>F8-5334</b>		d=16; D=60; Thick. [mm]=58
Engine Mounting	2.0 i 16V, 2.0 i 16V 4x4		<b>F8-5418</b>		
Engine Mounting	2.0 i, 2.0 i 16V, 2.0 i 16V 4x4, 2.0 i 4x4	ch.N1133945, N9020268 →;	<b>F8-5418</b>		
Engine Mounting	All Models		<b>F8-5436</b>		
Engine Mounting	2.0 i 16V, 2.0 i 16V 4x4, 2.0 i Turbo 4x4		<b>F8-5438</b>		
Engine Mounting	2.0 i, 2.0 i 4x4		<b>F8-5438</b>		
Engine Mounting	2.0 i 16V		<b>F8-5445</b>		
Engine Mounting	2.0 i 16V, 2.0 i 16V 4x4		<b>F8-5467</b>		
Engine Mounting	2.0 i 16V, 2.0 i 16V 4x4	ch.L9000001 →; ch. → N9020267;	<b>F8-5468</b>		
Engine Mounting	2.0 i, 2.0 i 4x4		<b>F8-5468</b>		
Top Strut Mounting	2.0 i, 2.0 i 16V, 2.0 i 16V 4x4, 2.0 i 4x4, 2.5 i V6		<b>F8-5501</b>		H=46; d=16; D=109
Top Strut Mounting	2.0 i, 2.0 i 16V, 2.0 i 16V 4x4, 2.0 i 4x4, 2.5 i V6		<b>F8-5501S</b>		
Rubber Buffer, suspension	2.0 i Turbo 4x4		<b>F8-5692</b>		H=67
Stabiliser Mounting	All Models		<b>F8-5724</b>		d=14
Control Arm-/Trailing Arm Bush	2.0 i 16V, 2.0 i 16V 4x4, 2.0 i Turbo 4x4, 2.5 i V6		<b>F8-5968</b>		d=12
Control Arm-/Trailing Arm Bush	2.0 i 16V, 2.0 i 16V 4x4, 2.0 i Turbo 4x4, 2.5 i V6	ch. → R9003174	<b>F8-5969</b>		H=58; d=16; D=60
Stabiliser Mounting	All Models		<b>F8-5970</b>		H=29; D1=32; D2=29
Sleeve, control arm mounting	All Models		<b>F8-6656</b>		
Top Strut Mounting	All Models	Bearing Type: Soft Version;	<b>F8-7973</b>		
Control Arm-/Trailing Arm Bush	All Models		<b>G9-593</b>		d=12; D1=39; D2=44
Control Arm-/Trailing Arm Bush	All Models		<b>G9-594</b>		H1=27; H2=58; d=16; D1=60; D2=66
C.V. Boot	All Models	ch. → R1..., R9...	<b>M-822900</b>		
Bellow Set, drive shaft	2.0 i, 2.0 i 16V, 2.0 i 16V 4x4, 2.0 i 4x4, 2.0 i Turbo 4x4		<b>MK-822920</b>		
<b>CARLTON Mk II</b>				<b>10/1978 → 08/1986</b>	
Dust Cover Kit, shock absorber	All Models		<b>AK-735005</b>		
Engine Mounting	2.2 i		<b>F7-2059</b>		Outer Thread 1 [mm]=M10 x 1,50 RHT M; Outer Thread 2 [mm]=M10 x 1,50 RHT M
<b>CARLTON Mk II Estate</b>				<b>09/1977 → 08/1986</b>	
Dust Cover Kit, shock absorber	1.8 S, 2.0 S, 2.2 i, 2.3 D		<b>AK-735005</b>		

<b>AK-735005</b>	<b>F7-2059</b>	<b>F8-4099</b>	<b>F8-5334</b>	<b>F8-5418</b>	<b>F8-5436</b>	<b>F8-5438</b>
Ref.Nr.:	Ref.Nr.: 24417107	Ref.Nr.: 0423313	Ref.Nr.: 352356	Ref.Nr.: 684646	Ref.Nr.: 0684641	Ref.Nr.: 684291
<b>F8-5445</b>	<b>F8-5467</b>	<b>F8-5468</b>	<b>F8-5501</b>	<b>F8-5501S</b>	<b>F8-5692</b>	<b>F8-5724</b>
Ref.Nr.: 0682504	Ref.Nr.: 0684285	Ref.Nr.: 0684283	Ref.Nr.: 90268464	Ref.Nr.: 90289421	Ref.Nr.: 0344411	Ref.Nr.: 0444153
<b>F8-5968</b>	<b>F8-5969</b>	<b>F8-5970</b>	<b>F8-6656</b>	<b>F8-7973</b>	<b>G9-593</b>	<b>G9-594</b>
Ref.Nr.: 352351	Ref.Nr.: 352352	Ref.Nr.: 0444347	Ref.Nr.: 4246062	Ref.Nr.: 344514	Ref.Nr.: 90288232	Ref.Nr.: 90268463

Article Description			Article Nr.	Fitting Position	
---------------------	--	--	-------------	------------------	--

<b>CARLTON Mk II Estate</b>			<b>09/1977 → 08/1986</b>		
Engine Mounting	1.9, 2.2 i		<b>F7-2059</b>		Outer Thread 1 [mm]=M10 x 1,50 RHT M; Outer Thread 2 [mm]=M10 x 1,50 RHT M
<b>CARLTON Mk III</b>			<b>09/1986 → 03/1994</b>		
Dust Cover Kit, shock absorber	1.8, 1.8 i, 1.8 N, 1.8 S, 2.0, 2.0 i, 2.2 TD, 2.3 D, 2.3 TD Interc., 2.4 i, 2.6 i, 3.0 3000, 3.0 3000 24V, 3000, 3000 24V, 3000 CAT		<b>AK-735037</b>		
Engine Mounting	1.8, 1.8 i, 1.8 N, 1.8 S, 2.0, 2.0 i, 2.4 i		<b>F7-2059</b>		Outer Thread 1 [mm]=M10 x 1,50 RHT M; Outer Thread 2 [mm]=M10 x 1,50 RHT M
Anti-Friction Bearing	1.8, 1.8 i, 1.8 N, 1.8 S, 2.0, 2.0 i, 2.2 TD, 2.3 D, 2.3 TD Interc., 2.4 i, 2.6 i, 3.0 3000, 3.0 3000 24V, 3000, 3000 24V, 3000 CAT		<b>F8-3024</b>		H=12; d=63; D=86
Control Arm-/Trailing Arm Bush	All Models		<b>F8-4097</b>		H1=26; H2=69; d=16; D1=27; D2=60
Control Arm-/Trailing Arm Bush	All Models		<b>F8-4098</b>		H=59; d=12; D1=33; D2=46
Control Arm-/Trailing Arm Bush	All Models		<b>F8-4099</b>		H=70; d=12; D1=46; D2=49
Top Strut Mounting	1.8, 1.8 i, 1.8 N, 1.8 S, 2.0, 2.0 i, 2.2 TD, 2.3 D, 2.3 TD Interc., 2.4 i, 2.6 i, 3.0 3000 24V, 3000 24V		<b>F8-4100</b>		H2=55; d=16; D1=96; D2=102
Mounting, alternator	3.0 3000		<b>F8-5366</b>		
Engine Mounting	1.8	ch.P1000001, P5000001, P7500001→; 	<b>F8-5418</b>		
Engine Mounting	1.8		<b>F8-5436</b>		
Engine Mounting	1.8	ch.→N1999999, N5999999, NV999999; 	<b>F8-5468</b>		
Stabiliser Mounting	1.8 i, 1.8 N, 1.8 S, 2.0, 2.0 i, 2.2 TD, 2.3 D, 2.3 TD Interc., 2.6 i, 3.0 3000, 3.6 24V Lotus, 3000 24V, 3000 CAT		<b>F8-5724</b>		d=14
Rubber Buffer, suspension	1.8 i, 1.8 N, 1.8 S, 2.0, 2.0 i, 2.6 i, 3.0 3000, 3.0 3000 24V, 3.6 24V Lotus, 3000, 3000 24V, 3000 CAT		<b>F8-5964</b>		H=62; d=29
Top Strut Mounting	3.0 3000, 3000, 3000 CAT		<b>F8-6324</b>		
Sleeve, control arm mounting	1.8		<b>F8-6656</b>		
Idler Arm	1.8 i, 1.8 N, 1.8 S, 2.0, 2.0 i, 2.4 i, 3.0 3000 24V		<b>F8-6659</b>		d=18; L=110
Joint, propshaft	1.8 i, 1.8 N, 1.8 S, 2.0, 2.0 i, 2.2 TD, 2.3 D, 2.3 TD Interc., 2.6 i, 3.0 3000, 3.6 24V Lotus, 3000 24V, 3000 CAT		<b>F8-6765</b>		d=50; D=127
Joint, propshaft	1.8, 1.8 i, 1.8 N, 1.8 S, 2.0, 2.0 i, 2.3 D		<b>F8-6766</b>		Bolt Hole Circle Ø [mm]=78; d=40; D=109
<b>CARLTON Mk III Estate</b>			<b>09/1986 → 03/1994</b>		
Dust Cover Kit, shock absorber	1.8, 1.8 i, 1.8 N, 1.8 S, 2.0, 2.0 i, 2.2 TD, 2.3 D, 2.3 TD Interc., 2.4 i, 2.6 i, 3.0, 3.0 24V		<b>AK-735037</b>		

<b>AK-735037</b>	<b>F7-2059</b>	<b>F8-3024</b>	<b>F8-4097</b>	<b>F8-4098</b>	<b>F8-4099</b>	<b>F8-4100</b>
Ref.Nr.: 1204885	Ref.Nr.: 24417107	Ref.Nr.: 90121275	Ref.Nr.: 352355	Ref.Nr.: 90279193	Ref.Nr.: 0423313	Ref.Nr.: 344511
<b>F8-5366</b>	<b>F8-5418</b>	<b>F8-5436</b>	<b>F8-5468</b>	<b>F8-5724</b>	<b>F8-5964</b>	<b>F8-6324</b>
Ref.Nr.: 4246062	Ref.Nr.: 684646	Ref.Nr.: 0684641	Ref.Nr.: 0684283	Ref.Nr.: 0444153	Ref.Nr.: 0344409	Ref.Nr.: 90251358
<b>F8-6656</b>	<b>F8-6659</b>	<b>F8-6765</b>	<b>F8-6766</b>			
Ref.Nr.: 4246062	Ref.Nr.: 920355	Ref.Nr.: 458367	Ref.Nr.: 0458364			





Article Description



Article Nr.

Fitting Position



<b>CARLTON Mk III Estate</b>		<b>09/1986 → 03/1994</b>	
Engine Mounting	1.8, 1.8 i, 1.8 N, 1.8 S, 2.0, 2.0 i, 2.4 i	<b>F7-2059</b>	Outer Thread 1 [mm]=M10 x 1,50 RHT M; Outer Thread 2 [mm]=M10 x 1,50 RHT M
Anti-Friction Bearing	1.8, 1.8 i, 1.8 N, 1.8 S, 2.0, 2.0 i, 2.2 TD, 2.3 D, 2.3 TD Interc., 2.4 i, 2.6 i, 3.0 24V	<b>F8-3024</b>	H=12; d=63; D=86
Control Arm-/Trailing Arm Bush	1.8, 1.8 i, 1.8 N, 1.8 S, 2.0, 2.0 i, 2.2 TD, 2.3 D, 2.3 TD Interc., 2.4 i, 2.6 i, 3.0, 3.0 24V	<b>F8-4097</b>	H1=26; H2=69; d=16; D1=27; D2=60
Control Arm-/Trailing Arm Bush	1.8, 1.8 i, 1.8 N, 1.8 S, 2.0, 2.0 i, 2.2 TD, 2.3 D, 2.3 TD Interc., 2.4 i, 2.6 i, 3.0, 3.0 24V	<b>F8-4098</b>	H=59; d=12; D1=33; D2=46
Control Arm-/Trailing Arm Bush	1.8, 1.8 i, 1.8 N, 1.8 S, 2.0, 2.0 i, 2.2 TD, 2.3 D, 2.3 TD Interc., 2.4 i, 2.6 i, 3.0, 3.0 24V	<b>F8-4099</b>	H=70; d=12; D1=46; D2=49
Top Strut Mounting	1.8, 1.8 i, 1.8 N, 1.8 S, 2.0, 2.0 i, 2.2 TD, 2.3 D, 2.3 TD Interc., 2.4 i, 2.6 i, 3.0 24V	<b>F8-4100</b>	H2=55; d=16; D1=96; D2=102
Stabiliser Mounting	1.8, 1.8 i, 1.8 N, 1.8 S, 2.0, 2.0 i, 2.2 TD, 2.3 D, 2.3 TD Interc., 2.6 i, 3.0, 3.0 24V	<b>F8-5724</b>	d=14
Rubber Buffer, suspension	1.8, 1.8 i, 1.8 N, 1.8 S, 2.0, 2.0 i, 2.6 i, 3.0, 3.0 24V	<b>F8-5964</b>	H=62; d=29
Top Strut Mounting	3.0	<b>F8-6324</b>	
Idler Arm	1.8, 1.8 i, 1.8 N, 1.8 S, 2.0, 2.0 i, 2.4 i	<b>F8-6659</b>	d=18; L=110
Joint, propshaft	2.0, 2.0 i, 2.2 TD, 2.3 TD Interc., 2.6 i, 3.0	<b>F8-6765</b>	d=50; D=127
Joint, propshaft	1.8, 1.8 i, 1.8 N, 1.8 S, 2.0, 2.0 i, 2.3 D	<b>F8-6766</b>	Bolt Hole Circle Ø [mm]=78; d=40; D=109
<b>CAVALIER Mk II</b>		<b>08/1981 → 08/1988</b>	
Dust Cover Kit, shock absorber	1.3 N, 1.3 S, 1.6 D, 1.6 i, 1.6 i CAT, 1.6 N, 1.6 S, 1.8, 1.8 i, 1.8 i CAT, 2.0 i, 2.0 i CAT, 2.0 SRI 130, 2000i	<b>AK-735003</b>	
Anti-Friction Bearing	1.3 N, 1.3 S, 1.6 D, 1.6 i, 1.6 i CAT, 1.6 N, 1.6 S, 1.8, 1.8 i, 1.8 i CAT, 2.0 i, 2.0 i CAT, 2.0 SRI 130	<b>F8-3024</b>	H=12; d=63; D=86
Mounting, axle beam	1.3 N, 1.3 S, 1.6 D, 1.6 i, 1.6 i CAT, 1.6 N, 1.6 S, 1.8, 1.8 i, 1.8 i CAT, 2.0 i, 2.0 i CAT, 2.0 SRI 130, 2000i	<b>F8-3060</b>	H=75; d=12; D1=49; D2=57
Mounting, axle beam	1.3 N, 1.3 S, 1.6 D, 1.6 i, 1.6 i CAT, 1.6 N, 1.6 S, 1.8, 1.8 i, 1.8 i CAT, 2.0 i, 2.0 i CAT, 2.0 SRI 130, 2000i	<b>F8-4102</b>	H=74; d=12; D1=60; D2=66
Rubber Buffer, suspension	1.3 N, 1.3 S, 1.6, 1.6 D, 1.6 i, 1.6 i CAT, 1.6 S, 1.8, 1.8 i, 1.8 i CAT, 2.0, 2.0 4x4, 2.0 i, 2.0 i CAT, 2.0 SRI 130, 2000i	<b>F8-5710</b>	H=46
Top Strut Mounting	1.3 S, 1.6, 1.6 D, 1.6 i, 1.6 S, 1.8, 1.8 i, 2.0, 2.0 4x4, 2.0 i, 2.0 SRI 130	<b>F8-5952</b>	
Bellow, steering	1.3 N, 1.3 S, 1.6 D, 1.6 i, 1.6 i CAT, 1.6 N, 1.6 S, 1.8, 1.8 i, 1.8 i CAT, 2.0 i, 2.0 i CAT, 2.0 SRI 130, 2000i	<b>LM-10045S</b>	with clamps d1=42; d2=52; L [mm]=165
Bellow, steering	1.3 N, 1.3 S, 1.6 D, 1.6 i, 1.6 i CAT, 1.6 N, 1.6 S, 1.8, 1.8 i, 1.8 i CAT, 2.0 i, 2.0 i CAT, 2.0 SRI 130, 2000i	<b>M-822300</b>	
C.V. Boot	1.6, 1.6 D, 1.6 S, 1.8, 2.0, 2.0 4x4, 2.0 i, 2.0 SRI 130	<b>M-822900</b>	
Bellow, steering	1.3 N, 1.3 S, 1.6 D, 1.6 i, 1.6 i CAT, 1.6 N, 1.6 S, 1.8, 1.8 i, 1.8 i CAT, 2.0 i, 2.0 i CAT, 2.0 SRI 130, 2000i	<b>MK-822300</b>	for OE: 90090811 H=165; d1=42; d2=52

<b>AK-735003</b>	<b>F7-2059</b>	<b>F8-3024</b>	<b>F8-3060</b>	<b>F8-4097</b>	<b>F8-4098</b>	<b>F8-4099</b>
Ref.Nr.:	Ref.Nr.: 24417107	Ref.Nr.: 90121275	Ref.Nr.: 90189050	Ref.Nr.: 352355	Ref.Nr.: 90279193	Ref.Nr.: 0423313
<b>F8-4100</b>	<b>F8-4102</b>	<b>F8-5710</b>	<b>F8-5724</b>	<b>F8-5952</b>	<b>F8-5964</b>	<b>F8-6324</b>
Ref.Nr.: 344511	Ref.Nr.: 90372559	Ref.Nr.: 0344402	Ref.Nr.: 0444153	Ref.Nr.: 0344504	Ref.Nr.: 0344409	Ref.Nr.: 90251358
<b>F8-6659</b>	<b>F8-6765</b>	<b>F8-6766</b>	<b>LM-10045S</b>	<b>M-822300</b>	<b>M-822900</b>	<b>MK-822300</b>
Ref.Nr.: 920355	Ref.Nr.: 458367	Ref.Nr.: 0458364	Ref.Nr.: 26024585	Ref.Nr.: 90090811	Ref.Nr.: 90421747	Ref.Nr.: 90345195

Article Description



Article Nr.

Fitting Position



<b>CAVALIER Mk II</b>		<b>08/1981 → 08/1988</b>	
Repair Kit, steering gear	1.3 N, 1.3 S, 1.6 D, 1.6 i, 1.6 i CAT, 1.6 N, 1.6 S, 1.8, 1.8 i, 1.8 i CAT, 2.0 i, 2.0 i CAT, 2.0 SRI 130, 2000i	for OE: 90090811	<b>MK-822300S</b>
Bellow Set, drive shaft	1.6 D, 1.6 S, 1.8, 1.8 i, 1.8 i CAT, 2.0 i, 2.0 i CAT, 2.0 SRI 130, 2000i		<b>MK-822920</b>
<b>CAVALIER Mk II Hatchback</b>		<b>09/1981 → 08/1988</b>	
Dust Cover Kit, shock absorber	1.3 S, 1.6 S, 1.8 i, 1600D, 2.0 i CAT, 2.0 SRI 130, 2000i		<b>AK-735003</b>
Anti-Friction Bearing	1.3 S, 1.6 S, 1.8 i, 1600D, 2.0 i CAT, 2.0 SRI 130		<b>F8-3024</b> H=12; d=63; D=86
Mounting, axle beam	1.3 S, 1.6 S, 1.8 i, 1600D, 2.0 i CAT, 2.0 SRI 130, 2000i		<b>F8-3060</b> H=75; d=12; D1=49; D2=57
Rubber Buffer, suspension	1.3, 1.3 S, 1.6 S, 1.8 i, 1600D, 2.0, 2.0 4x4, 2.0 i CAT, 2.0 SRI 130, 2000i		<b>F8-5710</b> H=46
Top Strut Mounting	1.3, 1.3 S, 1.6 S, 1.8 i, 1600D, 2.0, 2.0 4x4, 2.0 SRI 130		<b>F8-5952</b>
Bellow, steering	1.3 S, 1.6 S, 1.8 i, 1600D, 2.0 i CAT, 2.0 SRI 130, 2000i	with clamps	<b>LM-10045S</b> d1=42; d2=52; L [mm]=165
Bellow, steering	1.3 S, 1.6 S, 1.8 i, 1600D, 2.0 i CAT, 2.0 SRI 130, 2000i		<b>M-822300</b>
C.V. Boot	1.6 S, 1600D, 2.0, 2.0 4x4, 2.0 SRI 130		<b>M-822900</b>
Bellow, steering	1.3 S, 1.6 S, 1.8 i, 1600D, 2.0 i CAT, 2.0 SRI 130, 2000i	for OE: 90090811	<b>MK-822300</b> H=165; d1=42; d2=52
Repair Kit, steering gear	1.3 S, 1.6 S, 1.8 i, 1600D, 2.0 i CAT, 2.0 SRI 130, 2000i	for OE: 90090811	<b>MK-822300S</b>
Bellow Set, drive shaft	1.6 S, 1.8 i, 1600D, 2.0 i CAT, 2.0 SRI 130, 2000i		<b>MK-822920</b>
<b>CAVALIER Mk II Convertible</b>		<b>03/1985 → 10/1988</b>	
Rubber Buffer, suspension	All Models		<b>F8-5710</b> H=46
Top Strut Mounting	All Models		<b>F8-5952</b>
Bellow, steering	All Models	with clamps	<b>LM-10045S</b> d1=42; d2=52; L [mm]=165
Bellow, steering	All Models		<b>M-822300</b>
Bellow, steering	All Models	for OE: 90090811	<b>MK-822300</b> H=165; d1=42; d2=52
Repair Kit, steering gear	All Models	for OE: 90090811	<b>MK-822300S</b>
Bellow Set, drive shaft	All Models		<b>MK-822920</b>
<b>CAVALIER Mk II Estate</b>		<b>09/1981 → 08/1988</b>	
Dust Cover Kit, shock absorber	All Models		<b>AK-735003</b>
Mounting, axle beam	All Models		<b>F8-3060</b> H=75; d=12; D1=49; D2=57
Rubber Buffer, suspension	All Models		<b>F8-5710</b> H=46
Top Strut Mounting	1.6, 1.8 i		<b>F8-5952</b>
Bellow, steering	All Models	with clamps	<b>LM-10045S</b> d1=42; d2=52; L [mm]=165



**Article Description****Article Nr.****Fitting Position**

<b>CAVALIER Mk II Estate</b>			<b>09/1981 → 08/1988</b>		
Bellow, steering	All Models		<b>M-822300</b>		
C.V. Boot	1.6		<b>M-822900</b>		
Bellow, steering	All Models	for OE: 90090811	<b>MK-822300</b>		H=165; d1=42; d2=52
Repair Kit, steering gear	All Models	for OE: 90090811	<b>MK-822300S</b>		
Bellow Set, drive shaft	1.6, 1.8 i		<b>MK-822920</b>		
<b>CAVALIER Mk III (87)</b>			<b>08/1988 → 11/1995</b>		
Dust Cover Kit, shock absorber	1.4 S, 1.6, 1.6 i, 1.7 D, 1.7 TD, 1.8, 1.8 i CAT, 2.0 i, 2.0 i 16V, 2.0 i 16V 4x4, 2.0 i 4x4, 2.0 i Turbo 4x4, 2.0 SRi, 2.0 SRi 16V		<b>AK-735003</b>		
Anti-Friction Bearing	1.4 S, 1.6, 1.6 i, 1.7 D		<b>F8-3026</b>		H=11; d1=16; d2=22; D=41
Control Arm-Trailing Arm Bush	2.0 i 16V, 2.0 i 4x4, 2.0 SRi 16V		<b>F8-4099</b>		H=70; d=12; D1=46; D2=49
Control Arm-Trailing Arm Bush	1.4 S, 1.6, 1.6 i, 1.7 D, 1.7 TD, 1.8, 1.8 i CAT, 2.0 i, 2.0 i 16V, 2.0 i 16V 4x4, 2.0 i 4x4, 2.0 i CAT, 2.0 i Turbo 4x4, 2.0 SRi, 2.0 SRi 16V, 2.5 V6		<b>F8-5334</b>		d=16; D=60; Thick. [mm]=58
Mounting, alternator	1.6, 1.6 i	ch.→R1999999, R5999999, R7999999	<b>F8-5366</b>		
Engine Mounting	1.4 S		<b>F8-5372</b>		
Engine Mounting	1.6, 1.6 i		<b>F8-5372</b>		
Engine Mounting	1.7 TD		<b>F8-5391</b>		
Engine Mounting	1.8, 1.8 i CAT	ch.P1000001, P5000001, P7500001→;	<b>F8-5418</b>		
Engine Mounting	2.0 GSi, 2.0 GSi 4x4, 2.0 i 16V, 2.0 i 16V 4x4	ch.M5000001, N1133945→	<b>F8-5418</b>		
Engine Mounting	2.0 i, 2.0 i CAT	ch.→N1999999, N5999999, NV999999;	<b>F8-5418</b>		
Engine Mounting	2.0 i, 2.0 i CAT	ch.P1000001, P5000001, P7500001→;	<b>F8-5418</b>		
Engine Mounting	2.0 SRi 16V		<b>F8-5418</b>		
Engine Mounting	1.8, 1.8 i CAT, 2.0 GSi, 2.0 GSi 4x4, 2.0 i, 2.0 i 16V, 2.0 i 16V 4x4, 2.0 i 4x4, 2.0 i CAT, 2.0 i Turbo 4x4, 2.0 SRi, 2.0 SRi 16V, 2.5 V6		<b>F8-5436</b>		
Engine Mounting	1.8 i CAT		<b>F8-5438</b>		
Engine Mounting	1.8, 2.0 i 4x4, 2.0 SRi		<b>F8-5438</b>		
Engine Mounting	2.0 i 16V, 2.0 i 16V 4x4	ch.→L5999999, N1133944;	<b>F8-5438</b>		
Engine Mounting	2.0 i Turbo 4x4		<b>F8-5438</b>		
Engine Mounting	2.0 i, 2.0 i 4x4, 2.0 i CAT	ch.→N1999999, N5999999, NV999999;	<b>F8-5438</b>		
Engine Mounting	1.6, 1.6 i		<b>F8-5439</b>		
Engine Mounting	1.7 D		<b>F8-5439</b>		

<b>AK-735003</b>	<b>F8-3026</b>	<b>F8-4099</b>	<b>F8-5334</b>	<b>F8-5366</b>	<b>F8-5372</b>	<b>F8-5391</b>
Ref.Nr.:	Ref.Nr.: 90425479	Ref.Nr.: 0423313	Ref.Nr.: 352356	Ref.Nr.: 1204885	Ref.Nr.: 90278345	Ref.Nr.: 684643
<b>F8-5418</b>	<b>F8-5436</b>	<b>F8-5438</b>	<b>F8-5439</b>	<b>F8-5444</b>	<b>M-822300</b>	<b>M-822900</b>
Ref.Nr.: 684646	Ref.Nr.: 0684641	Ref.Nr.: 684291	Ref.Nr.: 684289	Ref.Nr.: 90473852	Ref.Nr.: 90090811	Ref.Nr.: 90421747
<b>MK-822300</b>	<b>MK-822300S</b>	<b>MK-822920</b>				
Ref.Nr.: 90345195	Ref.Nr.: 902828	Ref.Nr.: 811498203				

Article Description



Article Nr.

Fitting Position



**CAVALIER Mk III (87)**

08/1988 → 11/1995

Engine Mounting	1.4 S	09/1989 →	F8-5444		
Engine Mounting	1.6, 1.6 i, 1.7 TD		F8-5444		
Engine Mounting	1.8, 1.8 i CAT, 2.0 i, 2.0 i 16V, 2.0 i 16V 4x4, 2.0 i 4x4, 2.0 i CAT		F8-5445		
Engine Mounting	1.7 TD		F8-5462		
Engine Mounting	1.4 S		F8-5467		
Engine Mounting	1.7 D		F8-5468		
Engine Mounting	1.8, 1.8 i CAT	ch.→N1999999, N5999999, NV999999; 	F8-5468		
Engine Mounting	2.0 GSi, 2.0 GSi 4x4, 2.0 i 16V, 2.0 i 16V 4x4	ch.→L5999999, N1133944;	F8-5468		
Engine Mounting	2.0 i 4x4, 2.0 SRi		F8-5468		
Engine Mounting	2.0 i, 2.0 i 4x4, 2.0 i CAT	ch.→N1999999, N5999999, NV999999; 	F8-5468		
Top Strut Mounting	1.4 S, 1.6, 1.6 i, 1.7 D, 1.7 TD, 1.8, 1.8 i CAT, 2.0 i, 2.0 i 16V, 2.0 i 16V 4x4, 2.0 i 4x4, 2.0 i CAT, 2.0 i Turbo 4x4, 2.0 SRi, 2.0 SRi 16V, 2.5 V6		F8-5501		H=46; d=16; D=109
Top Strut Mounting	1.4 S, 1.6, 1.6 i, 1.7 D, 1.7 TD, 1.8, 1.8 i CAT, 2.0 i, 2.0 i 16V, 2.0 i 16V 4x4, 2.0 i 4x4, 2.0 i CAT, 2.0 i Turbo 4x4, 2.0 SRi, 2.0 SRi 16V, 2.5 V6		F8-5501S		
Rubber Buffer, suspension	1.4 S, 1.6, 1.6 i, 1.7 D, 1.7 TD, 1.8, 1.8 i CAT, 2.0 GSi, 2.0 GSi 4x4, 2.0 i, 2.0 i 16V, 2.0 i 16V 4x4, 2.0 i 4x4, 2.0 i CAT, 2.0 i Turbo 4x4, 2.0 SRi, 2.0 SRi 16V, 2.5 V6		F8-5692		H=67
Stabiliser Mounting	2.0 GSi, 2.0 GSi 4x4, 2.0 i 16V, 2.0 i 16V 4x4, 2.0 i 4x4, 2.0 i Turbo 4x4		F8-5724		d=14
Control Arm-/Trailing Arm Bush	2.0 GSi, 2.0 i 16V	ch.NV535972, P1001688, P5004911→	F8-5968		d=12
Control Arm-/Trailing Arm Bush	2.0 GSi, 2.0 GSi 4x4, 2.0 i, 2.0 i 16V, 2.0 i 16V 4x4, 2.0 i 4x4, 2.0 i CAT, 2.0 i Turbo 4x4, 2.0 SRi, 2.0 SRi 16V, 2.5 V6	ch.NV535972, P1001688, P5004911→; ch.→R1049314, R5112256, R7540515	F8-5969		H=58; d=16; D=60
Sleeve, control arm mounting	1.4 S, 1.6, 1.6 i, 1.7 D, 1.7 TD, 1.8, 1.8 i CAT, 2.0 GSi, 2.0 GSi 4x4, 2.0 i, 2.0 i 16V, 2.0 i 16V 4x4, 2.0 i 4x4, 2.0 i CAT, 2.0 i Turbo 4x4, 2.0 SRi, 2.0 SRi 16V, 2.5 V6		F8-6656		
Top Strut Mounting	All Models	Bearing Type: Soft Version;	F8-7973		
Control Arm-/Trailing Arm Bush	1.4 S, 1.6, 1.6 i, 1.7 D, 1.7 TD, 1.8, 1.8 i CAT, 2.0 i, 2.0 i 16V, 2.0 i 16V 4x4, 2.0 i 4x4, 2.0 i CAT, 2.0 i Turbo 4x4, 2.0 SRi, 2.0 SRi 16V, 2.5 V6		G9-593		d=12; D1=39; D2=44
Control Arm-/Trailing Arm Bush	1.4 S, 1.6, 1.6 i, 1.7 D, 1.7 TD, 1.8, 1.8 i CAT, 2.0 i, 2.0 i 16V, 2.0 i 16V 4x4, 2.0 i 4x4, 2.0 i CAT, 2.0 i Turbo 4x4, 2.0 SRi, 2.0 SRi 16V, 2.5 V6		G9-594		H1=27; H2=58; d=16; D1=60; D2=66

<b>F8-5444</b>	<b>F8-5445</b>	<b>F8-5462</b>	<b>F8-5467</b>	<b>F8-5468</b>	<b>F8-5501</b>	<b>F8-5501S</b>
Ref.Nr.: 90473852	Ref.Nr.: 0682504	Ref.Nr.: 684644	Ref.Nr.: 0684285	Ref.Nr.: 0684283	Ref.Nr.: 90268464	Ref.Nr.: 90289421
<b>F8-5692</b>	<b>F8-5724</b>	<b>F8-5968</b>	<b>F8-5969</b>	<b>F8-6656</b>	<b>F8-7973</b>	<b>G9-593</b>
Ref.Nr.: 0344411	Ref.Nr.: 0444153	Ref.Nr.: 352351	Ref.Nr.: 352352	Ref.Nr.: 4246062	Ref.Nr.: 344514	Ref.Nr.: 90288232
<b>G9-594</b>	<b>LM-10045S</b>					
Ref.Nr.: 90268463	Ref.Nr.: 26024585					

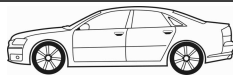
**Article Description****Article Nr.****Fitting Position**

<b>CAVALIER Mk III (87)</b>		<b>08/1988 → 11/1995</b>		
Bellow, steering	1.4 S, 1.6, 1.6 i, 1.7 D, 1.7 TD, 1.8, 1.8 i CAT, 2.0 GSi, 2.0 GSi 4x4, 2.0 i, 2.0 i 16V, 2.0 i 16V 4x4, 2.0 i 4x4, 2.0 i CAT, 2.0 i Turbo 4x4, 2.0 SRi, 2.0 SRi 16V, 2.5 V6	ch.→M1300967, M5396085, NV102027; with clamps;	<b>LM-10045S</b>	d1=42; d2=52; L [mm]=165
Bellow, steering	1.4 S, 1.6, 1.6 i, 1.7 D, 1.7 TD, 1.8, 1.8 i CAT, 2.0 GSi, 2.0 GSi 4x4, 2.0 i, 2.0 i 16V, 2.0 i 16V 4x4, 2.0 i 4x4, 2.0 i CAT, 2.0 i Turbo 4x4, 2.0 SRi, 2.0 SRi 16V, 2.5 V6	ch.→M1300967, M5396085, NV102027;	<b>M-822300</b>	
C.V. Boot	1.7 D, 1.7 TD, 1.8 i CAT, 2.0 GSi, 2.0 GSi 4x4, 2.0 i, 2.0 i 16V, 2.0 i 16V 4x4, 2.0 i 4x4, 2.0 i CAT, 2.0 i Turbo 4x4, 2.0 SRi, 2.0 SRi 16V	ch.→P1999999, P5999999, P7999999	<b>M-822900</b>	
Bellow, steering	1.4 S, 1.6, 1.6 i, 1.7 D, 1.7 TD, 1.8, 1.8 i CAT, 2.0 i, 2.0 i 16V, 2.0 i 16V 4x4, 2.0 i 4x4, 2.0 i CAT, 2.0 i Turbo 4x4, 2.0 SRi, 2.0 SRi 16V, 2.5 V6		<b>MK-822300</b>	H=165; d1=42; d2=52
Repair Kit, steering gear	1.4 S, 1.6, 1.6 i, 1.7 D, 1.7 TD, 1.8, 1.8 i CAT, 2.0 i, 2.0 i 16V, 2.0 i 16V 4x4, 2.0 i 4x4, 2.0 i CAT, 2.0 i Turbo 4x4, 2.0 SRi, 2.0 SRi 16V, 2.5 V6		<b>MK-822300S</b>	
Bellow Set, drive shaft	1.7 D, 1.7 TD, 1.8, 1.8 i CAT, 2.0 i, 2.0 i 16V, 2.0 i 16V 4x4, 2.0 i 4x4, 2.0 i CAT, 2.0 SRi		<b>MK-822920</b>	
<b>CAVALIER Mk III Hatchback</b>		<b>09/1988 → 11/1995</b>		
Dust Cover Kit, shock absorber	1.4 S, 1.6, 1.6 i, 1.7 D, 1.7 TD, 1.8, 1.8 i CAT, 2.0 i, 2.0 i 16V, 2.0 i 16V 4x4, 2.0 i 4x4, 2.0 SRi		<b>AK-735003</b>	
Anti-Friction Bearing	1.4 S, 1.6, 1.6 i, 1.7 D		<b>F8-3026</b>	H=11; d1=16; d2=22; D=41
Control Arm-/Trailing Arm Bush	2.0 i 16V		<b>F8-4099</b>	H=70; d=12; D1=46; D2=49
Mounting, axle beam	All Models		<b>F8-4102</b>	H=74; d=12; D1=60; D2=66
Control Arm-/Trailing Arm Bush	All Models		<b>F8-5334</b>	d=16; D=60; Thick. [mm]=58
Mounting, alternator	1.6, 1.6 i	ch.→R1999999, R5999999, R7999999	<b>F8-5366</b>	
Engine Mounting	1.4 S		<b>F8-5372</b>	
Engine Mounting	1.6, 1.6 i		<b>F8-5372</b>	
Engine Mounting	1.7 TD		<b>F8-5391</b>	
Engine Mounting	1.8 i CAT	ch.P1000001, P5000001, P7500001→;	<b>F8-5418</b>	
Engine Mounting	2.0 i 16V		<b>F8-5418</b>	
Engine Mounting	2.0 i 16V, 2.0 i 16V 4x4	ch.M5000001, N1133945→	<b>F8-5418</b>	
Engine Mounting	2.0 i, 2.0 i CAT	ch.→N1999999, N5999999, NV999999;	<b>F8-5418</b>	
Engine Mounting	2.0 i, 2.0 i CAT	ch.P1000001, P5000001, P7500001→;	<b>F8-5418</b>	
Engine Mounting	1.8 i CAT, 2.0 i, 2.0 i 16V, 2.0 i 16V 4x4, 2.0 i 4x4, 2.0 i CAT, 2.5 V6		<b>F8-5436</b>	
Engine Mounting	1.8 i CAT		<b>F8-5438</b>	

<b>AK-735003</b>	<b>F8-3026</b>	<b>F8-4099</b>	<b>F8-4102</b>	<b>F8-5334</b>	<b>F8-5366</b>	<b>F8-5372</b>
Ref.Nr.: <b>AK-735003</b>	Ref.Nr.: <b>90425479</b>	Ref.Nr.: <b>0423313</b>	Ref.Nr.: <b>90372559</b>	Ref.Nr.: <b>352356</b>	Ref.Nr.: <b>1204885</b>	Ref.Nr.: <b>90278345</b>
<b>F8-5391</b>	<b>F8-5418</b>	<b>F8-5436</b>	<b>F8-5438</b>	<b>LM-10045S</b>	<b>M-822300</b>	<b>M-822900</b>
Ref.Nr.: <b>684643</b>	Ref.Nr.: <b>684646</b>	Ref.Nr.: <b>0684641</b>	Ref.Nr.: <b>684291</b>	Ref.Nr.: <b>26024585</b>	Ref.Nr.: <b>90090811</b>	Ref.Nr.: <b>90421747</b>
<b>MK-822300</b>	<b>MK-822300S</b>	<b>MK-822920</b>				
Ref.Nr.: <b>90345195</b>	Ref.Nr.: <b>902828</b>	Ref.Nr.: <b>811498203</b>				

Article Description



Article Nr.

Fitting Position



**CAVALIER Mk III Hatchback**

09/1988 → 11/1995

Engine Mounting	1.8, 2.0 SRi		<b>F8-5438</b>		
Engine Mounting	2.0 i 16V	ch.→L5999999, N1133944;	<b>F8-5438</b>		
Engine Mounting	2.0 i, 2.0 i CAT	ch.→N1999999, N5999999, NV999999;	<b>F8-5438</b>		
Engine Mounting	1.6, 1.6 i		<b>F8-5439</b>		
Engine Mounting	1.7 D		<b>F8-5439</b>		
Engine Mounting	1.4 S	09/1989 →	<b>F8-5444</b>		
Engine Mounting	1.6, 1.6 i, 1.7 TD		<b>F8-5444</b>		
Engine Mounting	1.8, 1.8 i CAT, 2.0 i, 2.0 i 16V 4x4, 2.0 i 4x4, 2.0 i CAT		<b>F8-5445</b>		
Engine Mounting	1.7 TD		<b>F8-5462</b>		
Engine Mounting	1.4 S		<b>F8-5467</b>		
Engine Mounting	1.6 i, 1.7 D		<b>F8-5468</b>		
Engine Mounting	1.8, 1.8 i CAT	ch.→N1999999, N5999999, NV999999;	<b>F8-5468</b>		
Engine Mounting	2.0 i 16V, 2.0 i 16V 4x4	ch.→L5999999, N1133944;	<b>F8-5468</b>		
Engine Mounting	2.0 i 4x4, 2.0 SRi		<b>F8-5468</b>		
Engine Mounting	2.0 i, 2.0 i CAT	ch.→N1999999, N5999999, NV999999;	<b>F8-5468</b>		
Top Strut Mounting	All Models		<b>F8-5501</b>		H=46; d=16; D=109
Top Strut Mounting	All Models		<b>F8-5501S</b>		
Rubber Buffer, suspension	1.4 S, 1.6, 1.6 i, 1.7 D, 1.7 TD, 1.8 i CAT, 2.0 i, 2.0 i 16V, 2.0 i 16V 4x4, 2.0 i 4x4, 2.0 i CAT, 2.5 V6		<b>F8-5692</b>		H=67
Stabiliser Mounting	2.0 i 16V, 2.0 i 16V 4x4, 2.0 i 4x4		<b>F8-5724</b>		d=14
Control Arm-/Trailing Arm Bush	2.0 i 16V	ch.NV535972, P1001688, P5004911→	<b>F8-5968</b>		d=12
Control Arm-/Trailing Arm Bush	2.0 i, 2.0 i 16V, 2.0 i 16V 4x4, 2.0 i 4x4, 2.0 i CAT, 2.0 SRi, 2.5 V6	ch.NV535972, P1001688, P5004911→; ch.→R1049314, R5112256, R7540515	<b>F8-5969</b>		H=58; d=16; D=60
Sleeve, control arm mounting	All Models		<b>F8-6656</b>		
Top Strut Mounting	All Models	Bearing Type: Soft Version;	<b>F8-7973</b>		
Control Arm-/Trailing Arm Bush	All Models		<b>G9-593</b>		d=12; D1=39; D2=44
Control Arm-/Trailing Arm Bush	All Models		<b>G9-594</b>		H1=27; H2=58; d=16; D1=60; D2=66
Bellow, steering	All Models	ch.→M1300967, M5396085, NV102027; with clamps;	<b>LM-10045S</b>		d1=42; d2=52; L [mm]=165
Bellow, steering	All Models	ch.→M1300967, M5396085, NV102027;	<b>M-822300</b>		
C.V. Boot	1.7 D, 1.7 TD, 1.8 i CAT, 2.0 i, 2.0 i 16V, 2.0 i 16V 4x4, 2.0 i 4x4, 2.0 i CAT	ch.→P1999999, P5999999, P7999999	<b>M-822900</b>		



**Article Description****Article Nr.****Fitting Position**

<b>CAVALIER Mk III Hatchback</b>			<b>09/1988 → 11/1995</b>	
Bellow, steering	1.4 S, 1.6 i, 1.7 D, 1.7 TD, 1.8 i CAT, 2.0 i 16V, 2.0 i CAT, 2.5 V6		<b>MK-822300</b>	H=165; d1=42; d2=52
Repair Kit, steering gear	1.4 S, 1.6 i, 1.7 D, 1.7 TD, 1.8 i CAT, 2.0 i 16V, 2.0 i CAT, 2.5 V6		<b>MK-822300S</b>	
Bellow Set, drive shaft	1.7 D, 1.7 TD, 1.8, 1.8 i CAT, 2.0 i, 2.0 i 16V, 2.0 i 16V 4x4, 2.0 i 4x4, 2.0 i CAT, 2.0 SRi		<b>MK-822920</b>	
<b>COMBO Mk I (B)</b>			<b>07/1994 → 10/2001</b>	
Anti-Friction Bearing	1.2, 1.4, 1.7 D		<b>F8-3027</b>	H=27; d=12; D1=95; D2=130
Anti-Friction Bearing	1.2, 1.4, 1.7 D		<b>F8-3027</b>	H=27; d=12; D1=95; D2=130
Engine Mounting	1.4		<b>F8-5371</b>	
Engine Mounting	1.4		<b>F8-5437</b>	
Engine Mounting	1.7 D		<b>F8-5442</b>	
Top Strut Mounting	1.4, 1.7 D		<b>F8-5450</b>	
Rubber Buffer, suspension	1.2, 1.4		<b>F8-5707</b>	H=54
Tie Bar Bush	1.4, 1.7 D	ch.3037204→	<b>F8-6037</b>	
Tie Bar Bush	1.4, 1.7 D	ch.3037204→	<b>F8-6038</b>	
Engine Mounting	1.4, 1.7 D		<b>F8-8166</b>	
Control Arm-/Trailing Arm Bush	1.2, 1.4, 1.7 D		<b>G9-590</b>	H=52; d1=10; d2=14; D1=38; D2=45
<b>COMBO Mk II (C) Box Body / Estate (F25)</b>			<b>09/2001 → 02/2012</b>	
Alternator Freewheel Clutch	1.3 CDTI 16V		<b>F5-1041</b>	
Alternator Freewheel Clutch	1.3 CDTI 16V		<b>F5-1045</b>	
Alternator Freewheel Clutch	1.7 CDTI 16V		<b>F5-1049</b>	
Control Arm-/Trailing Arm Bush	1.3 CDTI 16V, 1.4 i 16V, 1.6, 1.7 CDTI 16V, 1.7 DI 16V, 1.7 DTI 16V		<b>F8-5262</b>	
Top Strut Mounting	1.4 i 16V, 1.6, 1.7 DI 16V, 1.7 DTI 16V	;	<b>F8-5463</b>	
Engine Mounting	1.3 CDTI 16V, 1.7 DI 16V, 1.7 DTI 16V		<b>F8-6753</b>	
Engine Mounting	1.4 i 16V, 1.6		<b>F8-6753</b>	
Rubber Buffer, suspension	1.4 i 16V, 1.6, 1.7 DI 16V, 1.7 DTI 16V		<b>F8-7698</b>	H=63
Engine Mounting	1.4 i 16V		<b>F8-7793</b>	
Engine Mounting	1.4 i 16V		<b>F8-7794</b>	
Engine Mounting	1.4 16V, 1.4 i 16V, 1.6, 1.7 DI 16V, 1.7 DTI 16V		<b>F8-8158</b>	
Engine Mounting	1.4 16V, 1.4 i 16V, 1.6, 1.7 DI 16V, 1.7 DTI 16V		<b>F8-8161</b>	
<b>COMBO TOUR Mk II (C) (F25)</b>			<b>09/2001 → 02/2012</b>	
Engine Mounting	1.4		<b>F8-7793</b>	
Engine Mounting	1.4		<b>F8-7794</b>	

<b>F5-1041</b>	<b>F5-1045</b>	<b>F5-1049</b>	<b>F8-3027</b>	<b>F8-5262</b>	<b>F8-5371</b>	<b>F8-5437</b>
Ref.Nr.: 77364723	Ref.Nr.: 77362721	Ref.Nr.: 1204366	Ref.Nr.: 90170695	Ref.Nr.: 13138151	Ref.Nr.: 0684669	Ref.Nr.: 0684294
<b>F8-5442</b>	<b>F8-5450</b>	<b>F8-5463</b>	<b>F8-5707</b>	<b>F8-6037</b>	<b>F8-6038</b>	<b>F8-6753</b>
Ref.Nr.: 0684126	Ref.Nr.: 0344519	Ref.Nr.: 0344525	Ref.Nr.: 0344403	Ref.Nr.: 0353281	Ref.Nr.: 0353280	Ref.Nr.: 0684238
<b>F8-7698</b>	<b>F8-7793</b>	<b>F8-7794</b>	<b>F8-8158</b>	<b>F8-8161</b>	<b>F8-8166</b>	<b>G9-590</b>
Ref.Nr.: 24403535	Ref.Nr.: 13125209	Ref.Nr.: 13125208	Ref.Nr.: 684713	Ref.Nr.: 846000	Ref.Nr.: 682600	Ref.Nr.: 0352301

Article Description			Article Nr.	Fitting Position	
---------------------	--	--	-------------	------------------	--

<b>COMBO TOUR Mk II (C) (F25)</b>			09/2001 → 02/2012		
Engine Mounting	1.4, 1.6, 1.7 DI 16V, 1.7 DTI 16V		F8-8158		
Engine Mounting	1.4, 1.6, 1.7 DI 16V, 1.7 DTI 16V		F8-8161		
<b>COMBO Mk III (D) Box Body / Estate</b>			11/2011 →		
Alternator Freewheel Clutch	1.3 CDTi		F5-1041		
Alternator Freewheel Clutch	1.6 CDTi, 2.0 CDTi		F5-1072		
Alternator Freewheel Clutch	1.3 CDTi, 1.6 CDTi, 2.0 CDTi		F5-1098		
Protective Cap/Bellow, shock absorber	All Models		F8-7663		H=205
<b>CORSA Mk I (B)</b>			12/1992 → 09/2000		
Dust Cover Kit, shock absorber	1.0 i 12V, 1.2 i, 1.4 i, 1.4 i 16V, 1.4 i S, 1.5 D, 1.5 TD, 1.6 GSI 16V, 1.6 i 16V, 1.7 D		AK-735003		
Anti-Friction Bearing	1.0 i 12V, 1.2 i, 1.4 i, 1.4 i 16V, 1.4 i S, 1.5 TD, 1.6 i 16V, 1.7 D		F8-3027		H=27; d=12; D1=95; D2=130
Tie Bar Bush	1.0 i 12V, 1.2 i, 1.2 i 16V, 1.4 i, 1.4 i 16V, 1.4 i S, 1.5 D, 1.5 TD, 1.6 GSI 16V, 1.6 i 16V, 1.7 D	ch.→V3023597, V4166925, V6066277	F8-5128		H=40; d=14; D=36, 50
Mounting, alternator	1.2 i, 1.4 i, 1.4 i S	ch.→R3999999, R4999999, R6999999	F8-5366		
Engine Mounting	1.2 i, 1.4 i, 1.4 i 16V, 1.4 i S		F8-5371		
Engine Mounting	1.0 i 12V, 1.2 i 16V, 1.4 i 16V, 1.6 GSI 16V, 1.6 i 16V		F8-5373		
Engine Mounting	1.2 i	ch.S4276217→;	F8-5373		
Engine Mounting	1.4 i, 1.4 i S		F8-5373		
Engine Mounting	1.4 i, 1.4 i S		F8-5437		
Engine Mounting	1.5 D, 1.5 TD, 1.7 D		F8-5441		
Engine Mounting	1.5 D, 1.5 TD, 1.7 D		F8-5442		
Top Strut Mounting	1.0 i 12V, 1.2 i, 1.2 i 16V, 1.4 i, 1.4 i 16V, 1.4 i S, 1.5 D, 1.5 TD, 1.6 GSI 16V, 1.6 i 16V, 1.7 D		F8-5450		
Control Arm-/Trailing Arm Bush	1.0 i 12V, 1.2 i, 1.2 i 16V, 1.4 i, 1.4 i 16V, 1.4 i S, 1.5 D, 1.5 TD, 1.6 GSI 16V, 1.6 i 16V, 1.7 D		F8-5552		d=10; L=65; D=42
Rubber Buffer, suspension	1.0 i 12V, 1.2 i, 1.2 i 16V, 1.4 i, 1.4 i 16V		F8-5707		H=54
Tie Bar Bush	1.0 i 12V, 1.2 i, 1.2 i 16V, 1.4 i, 1.4 i 16V, 1.4 i S, 1.5 D, 1.5 TD, 1.6 GSI 16V, 1.6 i 16V, 1.7 D	ch.→3023597, 4166925, 6066279	F8-6037		
Tie Bar Bush	1.0 i 12V, 1.2 i, 1.2 i 16V, 1.4 i, 1.4 i 16V, 1.4 i S, 1.5 D, 1.5 TD, 1.6 GSI 16V, 1.6 i 16V, 1.7 D	ch.→3023597	F8-6038		
Top Strut Mounting	1.0 i 12V, 1.2 i, 1.2 i 16V, 1.4 i, 1.4 i 16V, 1.4 i S, 1.5 D, 1.5 TD, 1.6 GSI 16V, 1.6 i 16V, 1.7 D		F8-6319		
Engine Mounting	1.0 i 12V, 1.2 i, 1.2 i 16V, 1.4 i, 1.4 i 16V, 1.4 i S, 1.5 D, 1.5 TD, 1.6 GSI 16V, 1.6 i 16V, 1.7 D		F8-8166		
Control Arm-/Trailing Arm Bush	1.0 i 12V, 1.2 i, 1.2 i 16V, 1.4 i, 1.4 i 16V, 1.4 i S, 1.5 D, 1.5 TD, 1.6 GSI 16V, 1.6 i 16V, 1.7 D		G9-590		H=52; d1=10; d2=14; D1=38; D2=45

<b>AK-735003</b>	<b>AK-735249</b>	<b>F5-1041</b>	<b>F5-1072</b>	<b>F5-1098</b>	<b>F8-3027</b>	<b>F8-5128</b>
Ref.Nr.: <b>344427</b>	Ref.Nr.: <b>344427</b>	Ref.Nr.: <b>77364723</b>	Ref.Nr.: <b>30667067</b>	Ref.Nr.: <b>77364725</b>	Ref.Nr.: <b>90170695</b>	Ref.Nr.: <b>90445098</b>
<b>F8-5366</b>	<b>F8-5371</b>	<b>F8-5373</b>	<b>F8-5437</b>	<b>F8-5441</b>	<b>F8-5442</b>	<b>F8-5450</b>
Ref.Nr.: <b>1204885</b>	Ref.Nr.: <b>0684669</b>	Ref.Nr.: <b>0684666</b>	Ref.Nr.: <b>0684294</b>	Ref.Nr.: <b>0684160</b>	Ref.Nr.: <b>0684126</b>	Ref.Nr.: <b>0344519</b>
<b>F8-5552</b>	<b>F8-5707</b>	<b>F8-6037</b>	<b>F8-6038</b>	<b>F8-6319</b>	<b>F8-7663</b>	<b>F8-8158</b>
Ref.Nr.: <b>90217845</b>	Ref.Nr.: <b>0344403</b>	Ref.Nr.: <b>0353281</b>	Ref.Nr.: <b>0353280</b>	Ref.Nr.: <b>0312503</b>	Ref.Nr.: <b>344435</b>	Ref.Nr.: <b>684713</b>



**Article Description****Article Nr.****Fitting Position**

<b>CORSA Mk II (C) (W5L, F08)</b>		<b>08/2000 → 10/2006</b>	
Dust Cover Kit, shock absorber	1.8 16V		AK-735249
Alternator Freewheel Clutch	1.0 12V, 1.2 16V, 1.2 16V Dualfuel, 1.3 CDTI 16V		F5-1041
Alternator Freewheel Clutch	1.0 12V, 1.2 16V, 1.2 16V Dualfuel, 1.3 CDTI 16V		F5-1045
Alternator Freewheel Clutch	1.7 CDTI 16V		F5-1049
Control Arm-/Trailing Arm Bush	1.0 12V, 1.2 16V, 1.2 16V Dualfuel, 1.3 CDTI 16V, 1.4 16V, 1.4 Twinport, 1.7 CDTI 16V, 1.7 DI 16V, 1.7 DTI 16V, 1.8 16V		F8-5262
Top Strut Mounting	1.0 12V, 1.2 16V, 1.2 16V Dualfuel, 1.3 CDTI 16V, 1.4 16V, 1.7 CDTI 16V, 1.7 DI 16V, 1.7 DTI 16V, 1.8 16V	Bearing Type: Soft Version;	F8-5448
Engine Mounting	1.0 12V, 1.2 16V, 1.2 16V Dualfuel		F8-6203
Rubber Buffer, suspension	1.0 12V, 1.2 16V, 1.2 16V Dualfuel, 1.3 CDTI 16V, 1.4 16V, 1.7 CDTI 16V, 1.7 DI 16V, 1.7 DTI 16V, 1.8 16V		F8-6517
Engine Mounting	1.3 CDTI 16V, 1.7 DI 16V, 1.7 DTI 16V, 1.8 16V		F8-6753
Engine Mounting	1.4 16V		F8-6753
Belt Pulley, crankshaft	1.7 DI 16V, 1.7 DTI 16V	Number of Ribs: 6	F8-7089
Rubber Buffer, suspension	1.0 12V, 1.2 16V, 1.2 16V Dualfuel, 1.3 CDTI 16V, 1.4 16V, 1.7 CDTI 16V, 1.7 DI 16V, 1.7 DTI 16V		F8-7698
Engine Mounting	1.0 12V, 1.2 16V, 1.2 16V Dualfuel, 1.2 Twinport, 1.4 Twinport		F8-7793
Engine Mounting	1.0 12V		F8-7794
Engine Mounting	1.0 12V, 1.2 16V, 1.2 16V Dualfuel, 1.2 Twinport, 1.4 Twinport		F8-7794
Stabiliser Mounting	1.0 12V, 1.2 16V, 1.2 16V Dualfuel, 1.2 Twinport		F8-7929
Engine Mounting	1.0 12V, 1.2 16V, 1.4 16V, 1.7 DI 16V, 1.7 DTI 16V, 1.8 16V		F8-8158
Engine Mounting	1.0 12V, 1.2 16V, 1.4 16V, 1.7 DI 16V, 1.7 DTI 16V, 1.8 16V		F8-8161
<b>CORSA Mk III (D) (L_8)</b>		<b>07/2006 → 08/2014</b>	
Dust Cover Kit, shock absorber	1.0, 1.2, 1.3 CDTI, 1.4, 1.6 VXR, 1.7 CDTI		AK-735250
Alternator Freewheel Clutch	1.3 CDTI		F5-1041
Alternator Freewheel Clutch	1.3 CDTI		F5-1045
Alternator Freewheel Clutch	1.7 CDTI		F5-1049
Alternator Freewheel Clutch	1.4, 1.4 LPG		F5-1135
Top Strut Mounting	1.2, 1.4	Bearing Type: Soft Version;	F8-5448
Control Arm-/Trailing Arm Bush	1.0, 1.2, 1.3 CDTI, 1.4, 1.6 SRi, 1.6 VXR, 1.7 CDTI		F8-6729
Top Strut Mounting	1.0, 1.0 i 12V, 1.2, 1.2 i 16V, 1.2 LPG, 1.3 CDTI, 1.4, 1.4 LPG, 1.6 SRi, 1.6 VXR, 1.7 CDTI		F8-7421

<b>AK-735249</b>	<b>AK-735250</b>	<b>F5-1041</b>	<b>F5-1045</b>	<b>F5-1049</b>	<b>F5-1135</b>	<b>F8-5262</b>
Ref.Nr.: 344427	Ref.Nr.:	Ref.Nr.: 77364723	Ref.Nr.: 77362721	Ref.Nr.: 1204366	Ref.Nr.: 1204184	Ref.Nr.: 13138151
<b>F8-5448</b>	<b>F8-6203</b>	<b>F8-6517</b>	<b>F8-6729</b>	<b>F8-6753</b>	<b>F8-7089</b>	<b>F8-7421</b>
Ref.Nr.: 0344523	Ref.Nr.: 24416554	Ref.Nr.: 90468618	Ref.Nr.: 352864	Ref.Nr.: 0684238	Ref.Nr.: 5614444	Ref.Nr.: 51813225
<b>F8-7422</b>	<b>F8-7698</b>	<b>F8-7793</b>	<b>F8-7794</b>	<b>F8-7929</b>	<b>F8-8158</b>	<b>F8-8161</b>
Ref.Nr.: 344963	Ref.Nr.: 24403535	Ref.Nr.: 13125209	Ref.Nr.: 13125208	Ref.Nr.: 350104	Ref.Nr.: 684713	Ref.Nr.: 846000

Article Description



Article Nr.

Fitting Position



### CORSA Mk III (D) (L\_8)

07/2006 → 08/2014

Spring Cap	All Models		F8-7422		
Top Strut Mounting	1.0, 1.0 i 12V, 1.2, 1.2 i 16V, 1.3 CDTI, 1.4, 1.6 SRi, 1.6 VXR, 1.7 CDTI		F8-7423		
Top Strut Mounting	1.0, 1.0 i 12V, 1.2, 1.2 i 16V, 1.3 CDTI, 1.4, 1.6 SRi, 1.6 VXR, 1.7 CDTI		F8-7424		
Rubber Buffer, suspension	1.4, 1.7 CDTI	ST	F8-7661		H=70
Rubber Buffer, suspension	1.0 i 12V, 1.2 i 16V, 1.3 CDTI, 1.4, 1.6 SRi, 1.6 VXR, 1.7 CDTI	SP	F8-7662		H=40
Rubber Buffer, suspension	1.2, 1.2 LPG, 1.4, 1.4 LPG, 1.6 VXR	QI	F8-7662		H=40
Protective Cap/Bellow, shock absorber	1.0 i 12V, 1.2, 1.2 i 16V, 1.2 LPG, 1.3 CDTI, 1.4, 1.6 VXR, 1.7 CDTI		F8-7663		H=205
Belt Pulley, crankshaft	1.7 CDTI	Number of Ribs: 5; Parameter: 6PK	F8-7872		Belt Pulley Ø [mm]=149; H1=22; H2=32

### CORSAVAN Mk I (B)

01/1994 → 09/2000

Dust Cover Kit, shock absorber	1.4 i, 1.7 D		AK-735003		
Mounting, alternator	1.4 i	ch.→R3999999, R4999999, R6999999	F8-5366		
Engine Mounting	1.4 i		F8-5371		
Engine Mounting	1.4 i	AU;	F8-5373		
Engine Mounting	1.4 i		F8-5437		
Engine Mounting	1.5 D, 1.7 D		F8-5441		
Engine Mounting	1.5 D, 1.7 D		F8-5442		
Top Strut Mounting	All Models		F8-5450		
Control Arm-/Trailing Arm Bush	1.4 i, 1.5 D		F8-5552		d=10; L=65; D=42
Rubber Buffer, suspension	1.4 i		F8-5707		H=54
Tie Bar Bush	All Models	ch.→3023597, 4166925, 6066279	F8-6037		
Tie Bar Bush	All Models	ch.→3023597, 4166925, 6066279	F8-6038		
Top Strut Mounting	1.4 i, 1.7 D		F8-6319		
Engine Mounting	All Models		F8-8166		
Control Arm-/Trailing Arm Bush	1.4 i, 1.7 D		G9-590		H=52; d1=10; d2=14; D1=38; D2=45

### CORSAVAN Mk II (C)

09/2000 → 06/2006

Alternator Freewheel Clutch	1.2 16V, 1.2 16V Dualfuel, 1.3 CDTI 16V		F5-1041		
Alternator Freewheel Clutch	1.2 16V, 1.2 16V Dualfuel, 1.3 CDTI 16V		F5-1045		
Control Arm-/Trailing Arm Bush	All Models		F8-5262		
Top Strut Mounting	1.2 16V, 1.2 16V Dualfuel, 1.3 CDTI 16V	Bearing Type: Soft Version;	F8-5448		
Top Strut Mounting	1.7 DI 16V, 1.7 DTI 16V		F8-5463		

<b>AK-735003</b>	<b>F5-1041</b>	<b>F5-1045</b>	<b>F8-5262</b>	<b>F8-5366</b>	<b>F8-5371</b>	<b>F8-5373</b>
Ref.Nr.:	Ref.Nr.: 77364723	Ref.Nr.: 77362721	Ref.Nr.: 13138151	Ref.Nr.: 1204885	Ref.Nr.: 0684669	Ref.Nr.: 0684666
<b>F8-5437</b>	<b>F8-5441</b>	<b>F8-5442</b>	<b>F8-5448</b>	<b>F8-5450</b>	<b>F8-5463</b>	<b>F8-5552</b>
Ref.Nr.: 0684294	Ref.Nr.: 0684160	Ref.Nr.: 0684126	Ref.Nr.: 0344523	Ref.Nr.: 0344519	Ref.Nr.: 0344525	Ref.Nr.: 90217845
<b>F8-5707</b>	<b>F8-6037</b>	<b>F8-6038</b>	<b>F8-6203</b>	<b>F8-6319</b>	<b>F8-7422</b>	<b>F8-7423</b>
Ref.Nr.: 0344403	Ref.Nr.: 0353281	Ref.Nr.: 0353280	Ref.Nr.: 24416554	Ref.Nr.: 0312503	Ref.Nr.: 344963	Ref.Nr.: 55701902

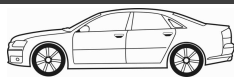
**Article Description****Article Nr.****Fitting Position**

<b>CORSAVAN Mk II (C)</b>			<b>09/2000 → 06/2006</b>		
Engine Mounting	1.2 16V, 1.2 16V Dualfuel		<b>F8-6203</b>		
Rubber Buffer, suspension	All Models		<b>F8-6517</b>		
Engine Mounting	1.3 CDTI 16V, 1.4, 1.7 DI 16V, 1.7 DTI 16V		<b>F8-6753</b>		
Belt Pulley, crankshaft	1.7 DI 16V, 1.7 DTI 16V	Engine614509→; Engine →614508; Number of Ribs: 6	<b>F8-7089</b>		Belt Pulley Ø [mm]=141; Mounting points diam.[mm]=48; W=27.5
Rubber Buffer, suspension	1.2 16V, 1.2 16V Dualfuel, 1.3 CDTI 16V, 1.7 DI 16V, 1.7 DTI 16V		<b>F8-7698</b>		H=63
Engine Mounting	1.2 16V, 1.2 16V Dualfuel, 1.4		<b>F8-7793</b>		
Engine Mounting	1.2 16V, 1.2 16V Dualfuel, 1.4		<b>F8-7794</b>		
Stabiliser Mounting	1.2 16V, 1.2 16V Dualfuel		<b>F8-7929</b>		d=15
Engine Mounting	1.2 16V, 1.7 DI 16V, 1.7 DTI 16V		<b>F8-8158</b>		
Engine Mounting	1.2 16V		<b>F8-8161</b>		
<b>CORSAVAN Mk III (D)</b>			<b>07/2006 →</b>		
Alternator Freewheel Clutch	1.3 CDTI		<b>F5-1041</b>		
Alternator Freewheel Clutch	1.3 CDTI		<b>F5-1045</b>		
Top Strut Mounting	1.2, 1.3 CDTI		<b>F8-7421</b>		
Spring Cap	All Models		<b>F8-7422</b>		
Rubber Buffer, suspension	1.2, 1.3 CDTI		<b>F8-7662</b>		H=40
Protective Cap/Bellow, shock absorber	1.2, 1.3 CDTI		<b>F8-7663</b>		H=205
<b>FRONTERA Mk I (A)</b>			<b>03/1992 → 10/1998</b>		
Mounting, alternator	2.4 i		<b>F8-5366</b>		
<b>FRONTERA Mk II (B)</b>			<b>10/1998 → 09/2004</b>		
Belt Pulley, crankshaft	2.2 DTI		<b>F8-5639</b>		
<b>INSIGNIA</b>			<b>07/2008 →</b>		
Dust Cover Kit, shock absorber	1.4, 1.6, 1.6 Turbo, 1.8, 2.0 Biturbo CDTI, 2.0 Biturbo CDTI 4x4, 2.0 CDTI, 2.0 CDTI 4x4, 2.0 Turbo, 2.0 Turbo 4x4, 2.8 V6 Turbo 4x4, 2.8 VXR		<b>AK-735434</b>		
Top Strut Mounting	1.4, 1.6, 1.6 Turbo, 1.8, 2.0 Biturbo CDTI, 2.0 Biturbo CDTI 4x4, 2.0 CDTI, 2.0 CDTI 4x4, 2.0 Turbo, 2.0 Turbo 4x4, 2.8 V6 Turbo 4x4, 2.8 VXR		<b>F8-7611</b>		
Top Strut Mounting	1.4, 1.6, 1.6 Turbo, 1.8, 2.0 Biturbo CDTI, 2.0 Biturbo CDTI 4x4, 2.0 CDTI, 2.0 CDTI 4x4, 2.0 Turbo, 2.0 Turbo 4x4, 2.8 V6 Turbo 4x4, 2.8 VXR		<b>F8-7612</b>		
Top Strut Mounting	1.4, 1.6, 1.6 Turbo, 1.8, 2.0 Biturbo CDTI, 2.0 Biturbo CDTI 4x4, 2.0 CDTI, 2.0 CDTI 4x4, 2.0 Turbo, 2.0 Turbo 4x4, 2.8 V6 Turbo 4x4, 2.8 VXR		<b>F8-7613</b>		

<b>AK-735434</b>	<b>F5-1041</b>	<b>F5-1045</b>	<b>F8-5366</b>	<b>F8-5639</b>	<b>F8-6203</b>	<b>F8-6517</b>
Ref.Nr.: 13243574	Ref.Nr.: 77364723	Ref.Nr.: 77362721	Ref.Nr.: 1204885	Ref.Nr.: 0614411	Ref.Nr.: 24416554	Ref.Nr.: 90468618
<b>F8-6753</b>	<b>F8-7089</b>	<b>F8-7421</b>	<b>F8-7422</b>	<b>F8-7611</b>	<b>F8-7612</b>	<b>F8-7613</b>
Ref.Nr.: 0684238	Ref.Nr.: 5614444	Ref.Nr.: 51813225	Ref.Nr.: 344963	Ref.Nr.: 0344469	Ref.Nr.: 436426	Ref.Nr.: 436427
<b>F8-7615</b>	<b>F8-7662</b>	<b>F8-7663</b>	<b>F8-7698</b>	<b>F8-7793</b>	<b>F8-7794</b>	<b>F8-7929</b>
Ref.Nr.: 436503	Ref.Nr.: 0344956	Ref.Nr.: 344435	Ref.Nr.: 24403535	Ref.Nr.: 13125209	Ref.Nr.: 13125208	Ref.Nr.: 350104

<b>Article Description</b>			<b>Article Nr.</b>	<b>Fitting Position</b>	
----------------------------	--	--	--------------------	-------------------------	--

<b>INSIGNIA</b>		<b>07/2008 →</b>			
Rubber Buffer, suspension	2.0 Biturbo CDTI 4x4, 2.0 CDTI 4x4, 2.0 Turbo 4x4, 2.8 V6 Turbo 4x4	; for vehicles with FlexRide suspension, , ,	<b>F8-7615</b>		
Mounting Kit, shock absorber	1.6 CNG	for article nr: A-3246GL & A-3246GR, F8-7327	<b>F8-7625</b>		
Rubber Buffer, suspension	1.4, 1.4 LPG, 1.6, 1.6 Turbo, 1.8, 2.0 Biturbo CDTI, 2.0 CDTI, 2.0 Turbo, 2.8 VXR	, ,	<b>F8-7810</b>		H=30
Rubber Buffer, suspension	2.0 Biturbo CDTI 4x4, 2.0 CDTI 4x4, 2.0 Turbo 4x4, 2.8 V6 Turbo 4x4	,	<b>F8-7810</b>		H=30
Protective Cap/Bellow, shock absorber	1.4, 1.4 LPG, 1.6, 1.6 Turbo, 1.8, 2.0 Biturbo CDTI, 2.0 Biturbo CDTI 4x4, 2.0 CDTI, 2.0 CDTI 4x4, 2.0 Turbo, 2.0 Turbo 4x4, 2.8 V6 Turbo 4x4, 2.8 VXR	, ,	<b>F8-7811</b>		H=195
Rubber Buffer, suspension	1.4, 1.6, 1.6 Turbo, 1.8, 2.0 Biturbo CDTI, 2.0 CDTI, 2.0 Turbo, 2.8 VXR	, , , , for vehicles without FlexRide suspension	<b>F8-7889</b>		
<b>INSIGNIA Saloon</b>		<b>07/2008 → 09/2013</b>			
Dust Cover Kit, shock absorber	1.4, 1.6, 1.6 Turbo, 1.8, 2.0 Biturbo CDTI, 2.0 Biturbo CDTI 4x4, 2.0 CDTI, 2.0 CDTI 4x4, 2.0 Turbo, 2.0 Turbo 4x4, 2.8 V6 Turbo 4x4, 2.8 VXR	, ,	<b>AK-735434</b>		
Top Strut Mounting	1.4, 1.6, 1.6 Turbo, 1.8, 2.0 Biturbo CDTI, 2.0 Biturbo CDTI 4x4, 2.0 CDTI, 2.0 CDTI 4x4, 2.0 Turbo, 2.0 Turbo 4x4, 2.8 V6 Turbo 4x4, 2.8 VXR	, , ,	<b>F8-7611</b>		
Top Strut Mounting	1.4, 1.6, 1.6 Turbo, 1.8, 2.0 Biturbo CDTI, 2.0 Biturbo CDTI 4x4, 2.0 CDTI, 2.0 CDTI 4x4, 2.0 Turbo, 2.0 Turbo 4x4, 2.8 V6 Turbo 4x4, 2.8 VXR	, , ,	<b>F8-7612</b>		
Top Strut Mounting	1.4, 1.6, 1.6 Turbo, 1.8, 2.0 Biturbo CDTI, 2.0 Biturbo CDTI 4x4, 2.0 CDTI, 2.0 CDTI 4x4, 2.0 Turbo, 2.0 Turbo 4x4, 2.8 V6 Turbo 4x4, 2.8 VXR	, , ,	<b>F8-7613</b>		
Rubber Buffer, suspension	2.0 Biturbo CDTI 4x4, 2.0 CDTI 4x4, 2.0 Turbo 4x4, 2.8 V6 Turbo 4x4	; for vehicles with FlexRide suspension, , ,	<b>F8-7615</b>		
Rubber Buffer, suspension	1.4, 1.4 LPG, 1.6, 1.6 Turbo, 1.8, 2.0 Biturbo CDTI, 2.0 CDTI, 2.0 Turbo, 2.8 VXR	, ,	<b>F8-7810</b>		H=30
Rubber Buffer, suspension	2.0 Biturbo CDTI 4x4, 2.0 CDTI 4x4, 2.0 Turbo 4x4, 2.8 V6 Turbo 4x4	,	<b>F8-7810</b>		H=30
Protective Cap/Bellow, shock absorber	1.4, 1.4 LPG, 1.6, 1.6 Turbo, 1.8, 2.0 Biturbo CDTI, 2.0 Biturbo CDTI 4x4, 2.0 CDTI, 2.0 CDTI 4x4, 2.0 Turbo, 2.0 Turbo 4x4, 2.8 V6 Turbo 4x4, 2.8 VXR	, ,	<b>F8-7811</b>		H=195
Rubber Buffer, suspension	1.4, 1.6, 1.6 Turbo, 1.8, 2.0 Biturbo CDTI, 2.0 CDTI, 2.0 Turbo, 2.8 VXR	, , , , for vehicles without FlexRide suspension	<b>F8-7889</b>		
<b>INSIGNIA Estate</b>		<b>07/2008 →</b>			
Dust Cover Kit, shock absorber	1.4, 1.6, 1.6 Turbo, 1.8, 2.0 Biturbo CDTI, 2.0 Biturbo CDTI 4x4, 2.0 CDTI, 2.0 CDTI 4x4, 2.0 Turbo, 2.0 Turbo 4x4, 2.8 V6 Turbo, 2.8 VXR	, ,	<b>AK-735434</b>		
Top Strut Mounting	3.0		<b>F8-5603</b>		H=50; d=14; D=145
Top Strut Mounting	1.4, 1.6, 1.6 Turbo, 1.8, 2.0 Biturbo CDTI, 2.0 Biturbo CDTI 4x4, 2.0 CDTI, 2.0 CDTI 4x4, 2.0 Turbo, 2.0 Turbo 4x4, 2.8 V6 Turbo, 2.8 VXR	, , ,	<b>F8-7611</b>		

<b>AK-735434</b>	<b>F8-5603</b>	<b>F8-7611</b>	<b>F8-7612</b>	<b>F8-7613</b>	<b>F8-7615</b>	<b>F8-7625</b>
Ref.Nr.: 13243574	Ref.Nr.: 82430666	Ref.Nr.: 0344469	Ref.Nr.: 436426	Ref.Nr.: 436427	Ref.Nr.: 436503	Ref.Nr.: 24402155
<b>F8-7810</b>	<b>F8-7811</b>	<b>F8-7889</b>				
Ref.Nr.: 13257624	Ref.Nr.: 344969	Ref.Nr.: 436504				

**Article Description****Article Nr.****Fitting Position**

<b>INSIGNIA Estate</b>		<b>07/2008 →</b>		
Top Strut Mounting	1.4, 1.6, 1.6 Turbo, 1.8, 2.0 Biturbo CDTi, 2.0 Biturbo CDTi 4x4, 2.0 CDTi, 2.0 CDTi 4x4, 2.0 Turbo, 2.0 Turbo 4x4, 2.8 V6 Turbo, 2.8 VXR	↗, ▲, <b>SP</b> , <b>ST</b>	<b>F8-7612</b>	
Top Strut Mounting	1.4, 1.6, 1.6 Turbo, 1.8, 2.0 Biturbo CDTi, 2.0 Biturbo CDTi 4x4, 2.0 CDTi, 2.0 CDTi 4x4, 2.0 Turbo, 2.0 Turbo 4x4, 2.8 V6 Turbo, 2.8 VXR	↗, ▲, <b>SP</b> , <b>ST</b>	<b>F8-7613</b>	
Rubber Buffer, suspension	2.0 Biturbo CDTi 4x4, 2.0 CDTi 4x4, 2.0 Turbo 4x4	<b>IV</b>	<b>F8-7615</b>	 
Rubber Buffer, suspension	1.4, 1.4 LPG, 1.6, 1.6 Turbo, 1.8, 2.0 Biturbo CDTi, 2.0 CDTi, 2.0 Turbo, 2.8 V6 Turbo, 2.8 VXR	▲, <b>SP</b> , <b>ST</b>	<b>F8-7810</b>	H=30
Rubber Buffer, suspension	2.0 Biturbo CDTi 4x4, 2.0 CDTi 4x4, 2.0 Turbo 4x4	<b>SP</b> , <b>ST</b>	<b>F8-7810</b>	H=30
Protective Cap/Bellow, shock absorber	1.4, 1.4 LPG, 1.6, 1.6 Turbo, 1.8, 2.0 Biturbo CDTi, 2.0 Biturbo CDTi 4x4, 2.0 CDTi, 2.0 CDTi 4x4, 2.0 Turbo, 2.0 Turbo 4x4, 2.8 V6 Turbo, 2.8 VXR	▲, <b>SP</b> , <b>ST</b>	<b>F8-7811</b>	H=195
Rubber Buffer, suspension	1.4, 1.6, 1.6 Turbo, 1.8, 2.0 Biturbo CDTi, 2.0 CDTi, 2.0 Turbo, 2.8 V6 Turbo	⊖, ▲, <b>SP</b> , <b>ST</b> , for vehicles without FlexRide suspension	<b>F8-7889</b>	 
<b>MERIVA Mk I (A)</b>		<b>01/2003 → 06/2010</b>		
Alternator Freewheel Clutch	1.3 CDTi		<b>F5-1041</b>	
Alternator Freewheel Clutch	1.3 CDTi		<b>F5-1045</b>	
Alternator Freewheel Clutch	1.7 CDTi 16V		<b>F5-1049</b>	
Control Arm-/Trailing Arm Bush	1.3 CDTi, 1.4 16V Twinport, 1.6 i, 1.6 i 16V, 1.6 i 16V Twinport, 1.6 Turbo, 1.7 CDTi, 1.7 CDTi 16V, 1.7 DTi 16V, 1.8 i 16V		<b>F8-5262</b>	 
Top Strut Mounting	1.3 CDTi, 1.4 16V Twinport, 1.6 i, 1.6 i 16V, 1.6 i 16V Twinport, 1.7 CDTi 16V, 1.8 i 16V	Bearing Type: Soft Version;	<b>F8-5448</b>	 
Top Strut Mounting	1.3 CDTi, 1.4 16V Twinport, 1.6 i, 1.6 i 16V, 1.6 i 16V Twinport, 1.6 Turbo, 1.7 CDTi 16V, 1.8 i 16V	▲	<b>F8-5463</b>	 
Rubber Buffer, suspension	1.3 CDTi, 1.4 16V Twinport, 1.6 i, 1.6 i 16V, 1.6 i 16V Twinport, 1.6 Turbo, 1.7 CDTi, 1.7 CDTi 16V, 1.8 i 16V		<b>F8-6517</b>	  
Engine Mounting	1.3 CDTi, 1.6 i 16V, 1.6 i 16V Twinport, 1.8 i 16V		<b>F8-6753</b>	
Engine Mounting	1.4 16V Twinport	Automated	<b>F8-6753</b>	
Engine Mounting	1.6 i		<b>F8-6753</b>	
Engine Mounting	1.4 16V Twinport		<b>F8-7793</b>	
Engine Mounting	1.4 16V Twinport		<b>F8-7794</b>	
Belt Pulley, crankshaft	1.7 CDTi	Number of Ribs: 5; Parameter: 6PK	<b>F8-7872</b>	Belt Pulley Ø [mm]=149; H1=22; H2=32
Engine Mounting	1.7 CDTi 16V		<b>F8-8158</b>	
<b>MERIVA Mk II (B)</b>		<b>06/2010 →</b>		
Alternator Freewheel Clutch	1.3 CDTi		<b>F5-1041</b>	
Alternator Freewheel Clutch	1.3 CDTi		<b>F5-1045</b>	
Alternator Freewheel Clutch	1.7 CDTi		<b>F5-1049</b>	

<b>F5-1041</b>	<b>F5-1045</b>	<b>F5-1049</b>	<b>F5-1135</b>	<b>F8-5262</b>	<b>F8-5448</b>	<b>F8-5463</b>
Ref.Nr.: 77364723	Ref.Nr.: 77362721	Ref.Nr.: 1204366	Ref.Nr.: 1204184	Ref.Nr.: 13138151	Ref.Nr.: 0344523	Ref.Nr.: 0344525
<b>F8-6517</b>	<b>F8-6753</b>	<b>F8-7612</b>	<b>F8-7613</b>	<b>F8-7615</b>	<b>F8-7793</b>	<b>F8-7794</b>
Ref.Nr.: 90468618	Ref.Nr.: 0684238	Ref.Nr.: 436426	Ref.Nr.: 436427	Ref.Nr.: 436503	Ref.Nr.: 13125209	Ref.Nr.: 13125208
<b>F8-7810</b>	<b>F8-7811</b>	<b>F8-7872</b>	<b>F8-7889</b>	<b>F8-8158</b>		
Ref.Nr.: 13257624	Ref.Nr.: 344969	Ref.Nr.: 614758	Ref.Nr.: 436504	Ref.Nr.: 684713		

Article Description



Article Nr.

Fitting Position



### MERIVA Mk II (B)

06/2010 →

Alternator Freewheel Clutch	1.4	ch.C4000001→	F5-1135		
Alternator Freewheel Clutch	1.4	ch.→B4999999	F5-1141		
Engine Mounting	1.4	Code: KZ JE	F8-6975		
Engine Mounting	1.4, 1.4 LPG	Code: KZ JE;	F8-6975		
Engine Mounting	1.7 CDTi	Code: KZ KA;	F8-6984		
Spring Cap	1.3 CDTi, 1.4, 1.4 LPG, 1.7 CDTi		F8-7422		
Rubber Buffer, suspension	1.3 CDTi, 1.4, 1.4 LPG, 1.7 CDTi		F8-7662		H=40
Protective Cap/Bellow, shock absorber	1.3 CDTi, 1.4, 1.4 LPG, 1.7 CDTi		F8-7663		H=205
Rubber Buffer, suspension	1.3 CDTi, 1.4, 1.7 CDTi		F8-7699		H=50
Belt Pulley, crankshaft	1.7 CDTi	Number of Ribs: 5; Parameter: 6PK	F8-7872		Belt Pulley Ø [mm]=149; H1=22; H2=32
Engine Mounting	1.4		F8-8142		

### MOKKA

06/2012 →

Belt Pulley, crankshaft	1.7 CDTi, 1.7 CDTi 4x4	Number of Ribs: 5; Parameter: 6PK	F8-7872		Belt Pulley Ø [mm]=149; H1=22; H2=32
-------------------------	------------------------	-----------------------------------	---------	--	--------------------------------------

### MOVANO Mk I (A) Chassis/Cab (ED, UD, HD)

10/1998 → 05/2010

Alternator Freewheel Clutch	2.2 DTi		F5-1063		
Engine Mounting	2.2 DTi, 2.5 CDTi, 2.5 DTi, 3.0 DTi		F8-6524		
Control Arm-/Trailing Arm Bush	2.2 DTi, 2.5 CDTi, 2.5 D, 2.5 DTi, 2.8 DTi		F8-6673		H=74; d=28; D=55,2
Control Arm-/Trailing Arm Bush	2.2 DTi, 2.5 CDTi, 2.5 D, 2.5 DTi, 2.8 DTi, 3.0 DTi		F8-6674		H=79; d=28; D=55,5
Mounting, leaf spring	All Models		F8-6684		
Control Arm-/Trailing Arm Bush	2.2 DTi, 2.5 CDTi, 2.5 DTi, 2.8 DTi		F8-6687		
Engine Mounting	2.5 DTi		F8-6688		
Bellow, steering	All Models	with clamps	LM-10032S		d1=9.5; d2=42; L [mm]=165

### MOVANO Mk I (A) Combi (JD)

10/1998 → 05/2010

Alternator Freewheel Clutch	2.2 DTi		F5-1063		
Gear, camshaft	1.9 DTi	Engine Management: Timing Belt;  40	F8-6254		d=13; D=120; W=30
Engine Mounting	1.9 DTi, 2.2 DTi, 2.5 CDTi, 2.5 DTi, 3.0 DTi		F8-6524		
Control Arm-/Trailing Arm Bush	All Models		F8-6673		H=74; d=28; D=55,2
Control Arm-/Trailing Arm Bush	1.9 DTi, 2.2 DTi, 2.5 CDTi, 2.5 D, 2.5 DTi, 2.8 DTi, 3.0 DTi		F8-6674		H=79; d=28; D=55,5
Mounting, leaf spring	All Models		F8-6684		
Control Arm-/Trailing Arm Bush	3.0 DTi		F8-6687		

<b>F5-1063</b>	<b>F5-1135</b>	<b>F5-1141</b>	<b>F8-6254</b>	<b>F8-6524</b>	<b>F8-6673</b>	<b>F8-6674</b>
Ref.Nr.:	Ref.Nr.: 1204184	Ref.Nr.:	Ref.Nr.: 8200125710	Ref.Nr.: 8200027176	Ref.Nr.: 54570-00QAA	Ref.Nr.: 4500095
<b>F8-6684</b>	<b>F8-6687</b>	<b>F8-6688</b>	<b>F8-6975</b>	<b>F8-6984</b>	<b>F8-7422</b>	<b>F8-7662</b>
Ref.Nr.: 55046-00QAB	Ref.Nr.: 4500091	Ref.Nr.: 9110612	Ref.Nr.: 24459803	Ref.Nr.: 13159997	Ref.Nr.: 344963	Ref.Nr.: 0344956
<b>F8-7663</b>	<b>F8-7699</b>	<b>F8-7872</b>	<b>F8-8142</b>	<b>LM-10032S</b>		
Ref.Nr.: 344435	Ref.Nr.: 13117280	Ref.Nr.: 614758	Ref.Nr.: 90538582	Ref.Nr.: 7701470361		



Article Description



Article Nr.

Fitting Position



<b>MOVANO Mk I (A) Combi (JD)</b>				<b>10/1998 → 05/2010</b>	
Engine Mounting	1.9 DTI, 2.5 DTI		<b>F8-6688</b>		
Bellow, steering	All Models	with clamps	<b>LM-10032S</b>		d1=9.5; d2=42; L [mm]=165
<b>MOVANO Mk I (A) Van (FD)</b>				<b>10/1998 → 05/2010</b>	
Alternator Freewheel Clutch	2.2 DTI		<b>F5-1063</b>		
Gear, camshaft	1.9 DTI	Engine Management: Timing Belt; ⦿ 40	<b>F8-6254</b>		d=13; D=120; W=30
Engine Mounting	1.9 DTI, 2.2 DTI, 2.5 CDTI, 2.5 DTI, 3.0 DTI		<b>F8-6524</b>		
Control Arm-/Trailing Arm Bush	1.9 DTI, 2.2 DTI, 2.5 CDTI, 2.5 DTI, 2.8 DTI		<b>F8-6673</b>	⊕ ⊕ ↓	H=74; d=28; D=55,2
Control Arm-/Trailing Arm Bush	1.9 DTI, 2.2 DTI, 2.5 CDTI, 2.5 D, 2.5 DTI, 2.8 TDI, 3.0 DTI		<b>F8-6674</b>	⊕ ⊕ ↓	H=79; d=28; D=55,5
Mounting, leaf spring	All Models		<b>F8-6684</b>		
Control Arm-/Trailing Arm Bush	1.9 DTI, 2.2 DTI, 2.5 CDTI, 2.5 DTI, 2.8 DTI		<b>F8-6687</b>	⊕ ⊕ ↑	
Engine Mounting	1.9 DTI		<b>F8-6688</b>		
Bellow, steering	All Models	with clamps	<b>LM-10032S</b>		d1=9.5; d2=42; L [mm]=165
<b>MOVANO Mk II (B) Chassis/Cab</b>				<b>05/2010 →</b>	
Alternator Freewheel Clutch	2.3 CDTI [RWD], 2.3 CDTI FWD		<b>F5-1110</b>		
Alternator Freewheel Clutch	All Models		<b>F5-1129</b>		
<b>MOVANO Mk II (B) Combi</b>				<b>05/2010 →</b>	
Alternator Freewheel Clutch	2.3 CDTI		<b>F5-1110</b>		
Alternator Freewheel Clutch	2.3 CDTI		<b>F5-1129</b>		
<b>MOVANO Mk II (B) VAN</b>				<b>05/2010 →</b>	
Alternator Freewheel Clutch	2.3 CDTI [RWD], 2.3 CDTI FWD		<b>F5-1110</b>		
Alternator Freewheel Clutch	2.3 CDTI [RWD], 2.3 CDTI FWD		<b>F5-1129</b>		
<b>NOVA</b>				<b>09/1982 → 02/1993</b>	
Dust Cover Kit, shock absorber	1.0, 1.2 N, 1.2 S, 1.3 i, 1.3 S, 1.5 D, 1.5 TD		<b>AK-735003</b>	⊕ ⊕	
Control Arm-/Trailing Arm Bush	1.0, 1.2 N, 1.2 S, 1.3 i, 1.3 S, 1.4 S, 1.5 D, 1.5 TD		<b>F8-5112</b>	⊕ ⊕	H=52; d=10; D=33
Mounting, alternator	1.0, 1.2 N		<b>F8-5366</b>		
Top Strut Mounting	1.0, 1.2 N, 1.3 i, 1.3 S, 1.4, 1.4 S, 1.5 D		<b>F8-5434</b>	⊕ ⊕	
Engine Mounting	1.5 D, 1.5 TD		<b>F8-5440</b>	⊕	
Control Arm-/Trailing Arm Bush	1.0, 1.2 N, 1.2 S, 1.3 i, 1.3 S, 1.4, 1.5 D, 1.5 TD		<b>F8-5552</b>	⊕ ⊕	d=10; L=65; D=42
Rubber Buffer, suspension	1.0, 1.2 N, 1.2 S, 1.3 i, 1.4, 1.4 S, 1.5 D, 1.5 TD		<b>F8-5707</b>	⊕ ⊕	H=54
Engine Mounting	1.4, 1.4 S		<b>F8-8145</b>		

<b>AK-735003</b>	<b>F5-1063</b>	<b>F5-1110</b>	<b>F5-1129</b>	<b>F8-5112</b>	<b>F8-5366</b>	<b>F8-5434</b>
Ref.Nr.:	Ref.Nr.:	Ref.Nr.: 8200489514	Ref.Nr.: 23151-JG71B	Ref.Nr.: 0352327	Ref.Nr.: 1204885	Ref.Nr.: 344507
<b>F8-5440</b>	<b>F8-5552</b>	<b>F8-5707</b>	<b>F8-6254</b>	<b>F8-6524</b>	<b>F8-6673</b>	<b>F8-6674</b>
Ref.Nr.: 684281	Ref.Nr.: 90217845	Ref.Nr.: 0344403	Ref.Nr.: 8200125710	Ref.Nr.: 8200027176	Ref.Nr.: 54570-00QAA	Ref.Nr.: 4500095
<b>F8-6684</b>	<b>F8-6687</b>	<b>F8-6688</b>	<b>F8-8145</b>	<b>LM-10032S</b>		
Ref.Nr.: 55046-00QAB	Ref.Nr.: 4500091	Ref.Nr.: 9110612	Ref.Nr.: 90189509	Ref.Nr.: 7701470361		

<b>Article Description</b>			<b>Article Nr.</b>	<b>Fitting Position</b>	
----------------------------	--	--	--------------------	-------------------------	--

<b>NOVA Hatchback</b>			<b>05/1983 → 03/1993</b>		
Dust Cover Kit, shock absorber	1.0, 1.2 i, 1.2 i CAT, 1.2 N, 1.2 S, 1.3 i, 1.3 i CAT, 1.3 S, 1.4 i, 1.4 i S, 1.4 S, 1.5 D, 1.5 TD, 1.6 GSI, 1.6 GSI CAT		<b>AK-735003</b>		
Control Arm-/Trailing Arm Bush	1.0, 1.2 i, 1.2 i CAT, 1.2 N, 1.2 S, 1.3 i, 1.3 i CAT, 1.3 S, 1.4 i, 1.4 i S, 1.4 S, 1.5 D, 1.5 TD, 1.6 GSI, 1.6 GSI CAT		<b>F8-5112</b>		H=52; d=10; D=33
Mounting, alternator	1.0, 1.2 i, 1.2 i CAT, 1.2 N, 1.6 GSI		<b>F8-5366</b>		
Top Strut Mounting	1.0, 1.2 i, 1.2 i CAT, 1.2 N, 1.2 S, 1.3 i, 1.3 i CAT, 1.3 S, 1.4 i, 1.4 i S, 1.4 S, 1.5 D, 1.5 TD, 1.6 GSI, 1.6 GSI CAT		<b>F8-5434</b>		
Engine Mounting	1.5 D, 1.5 TD		<b>F8-5440</b>		
Control Arm-/Trailing Arm Bush	1.0, 1.2 i, 1.2 i CAT, 1.2 N, 1.2 S, 1.3 i, 1.3 i CAT, 1.3 S, 1.4 i, 1.4 i S, 1.4 S, 1.5 D, 1.5 TD, 1.6 GSI, 1.6 GSI CAT		<b>F8-5552</b>		d=10; L=65; D=42
Rubber Buffer, suspension	1.0, 1.2 i, 1.2 i CAT, 1.2 N, 1.2 S, 1.3 i, 1.3 i CAT, 1.3 S, 1.4 i, 1.4 i S, 1.4 S, 1.5 D, 1.5 TD, 1.6 GSI, 1.6 GSI CAT		<b>F8-5707</b>		H=54
Engine Mounting	1.4 i, 1.4 S		<b>F8-8145</b>		
Engine Mounting	1.5 D		<b>F8-8166</b>		
<b>NOVAVAN</b>			<b>01/1990 → 10/1994</b>		
Control Arm-/Trailing Arm Bush	1.2, 1.5 D		<b>F8-5112</b>		H=52; d=10; D=33
Engine Mounting	1.5 D		<b>F8-5440</b>		
Control Arm-/Trailing Arm Bush	1.2		<b>F8-5552</b>		d=10; L=65; D=42
Rubber Buffer, suspension	All Models		<b>F8-5707</b>		H=54
Engine Mounting	1.4		<b>F8-8145</b>		
Engine Mounting	1.5 D		<b>F8-8166</b>		
<b>OMEGA (B)</b>			<b>01/1994 → 07/2003</b>		
Dust Cover Kit, shock absorber	All Models		<b>AK-735037</b>		
Engine Mounting	2.0, 2.0 16V, 2.2 16V		<b>F7-2059</b>		Outer Thread 1 [mm]=M10 x 1,50 RHT M; Outer Thread 2 [mm]=M10 x 1,50 RHT M
Anti-Friction Bearing	2.0, 2.0 16V, 2.0 DTI 16V, 2.2 16V, 2.5 TD, 2.5 V6		<b>F8-3024</b>		H=12; d=63; D=86
Top Strut Mounting	2.0, 2.0 16V, 2.0 DTI 16V, 2.2 16V, 2.5 TD, 2.5 V6		<b>F8-4100</b>		H2=55; d=16; D1=96; D2=102
Control Arm-/Trailing Arm Bush	2.0, 2.0 16V, 2.0 DTI 16V, 2.2 16V, 2.5 TD, 2.5 V6, 3.0 V6		<b>F8-5337</b>		d=19; D=100
Belt Pulley, crankshaft	2.0 DTI 16V, 2.2 DTI 16V		<b>F8-5639</b>		
Control Arm-/Trailing Arm Bush	2.0, 2.0 16V, 2.0 DTI 16V, 2.2 16V, 2.2 DTI 16V, 2.5 TD, 2.5 V6, 2.6 V6, 3.0 V6, 3.2 V6		<b>F8-5722</b>		H=71; d=12; D=43
Mounting, axle beam	2.0, 2.0 16V, 2.0 DTI 16V, 2.2 16V, 2.2 DTI 16V, 2.5 TD, 2.5 V6, 2.6 V6, 3.0 V6, 3.2 V6		<b>F8-5911</b>		H=59; D=47.5

<b>AK-735003</b>	<b>AK-735037</b>	<b>F7-2059</b>	<b>F8-3024</b>	<b>F8-4100</b>	<b>F8-5112</b>	<b>F8-5337</b>
Ref.Nr.:	Ref.Nr.:	Ref.Nr.: 24417107	Ref.Nr.: 90121275	Ref.Nr.: 344511	Ref.Nr.: 0352327	Ref.Nr.: 90447156
<b>F8-5366</b>	<b>F8-5434</b>	<b>F8-5440</b>	<b>F8-5552</b>	<b>F8-5639</b>	<b>F8-5707</b>	<b>F8-5722</b>
Ref.Nr.: 1204885	Ref.Nr.: 344507	Ref.Nr.: 684281	Ref.Nr.: 90217845	Ref.Nr.: 0614411	Ref.Nr.: 0344403	Ref.Nr.: 0423315
<b>F8-5911</b>	<b>F8-5970</b>	<b>F8-8145</b>	<b>F8-8166</b>			
Ref.Nr.: 0402649	Ref.Nr.: 0444347	Ref.Nr.: 90189509	Ref.Nr.: 682600			



**Article Description****Article Nr.****Fitting Position**

<b>OMEGA (B)</b>			<b>01/1994 → 07/2003</b>		
Stabiliser Mounting	2.0, 2.0 16V, 2.0 DTI 16V, 2.2 16V, 2.2 DTI 16V, 2.5 TD, 2.5 V6, 2.6 V6, 3.0 V6, 3.2 V6		<b>F8-5970</b>		H=29; D1=32; D2=29
Stabiliser Mounting	2.0, 2.0 16V, 2.0 DTI 16V, 2.2 16V, 2.2 DTI 16V, 2.5 TD, 2.5 V6, 2.6 V6, 3.0 V6, 3.2 V6		<b>F8-6091</b>		d=23; L=40
Top Strut Mounting	All Models		<b>F8-6324</b>		
Idler Arm	2.0, 2.0 16V, 2.0 DTI 16V, 2.2 16V, 2.2 DTI 16V, 2.5 TD, 2.5 V6, 2.6 V6, 3.0 V6, 3.2 V6		<b>F8-6659</b>		d=18; L=110
Joint, propshaft	2.0, 2.0 16V		<b>F8-6766</b>		Bolt Hole Circle Ø [mm]=78; d=40; D=109
Engine Mounting	2.5 V6, 3.0 V6	ch.R1127219→; ch.→11125192	<b>F8-7850</b>		Outer Thread 1 [mm]=M10 x 1,50 RHT M; Outer Thread 2 [mm]=M10 x 1,50 RHT M
Engine Mounting	2.6 V6, 3.2 V6	ch.11125193→	<b>F8-7850</b>		Outer Thread 1 [mm]=M10 x 1,50 RHT M; Outer Thread 2 [mm]=M10 x 1,50 RHT M
Engine Mounting	2.5 DTI 24V	Paired article nr: F8-6499	<b>F8-7879</b>		
<b>OMEGA (B) Estate</b>			<b>02/1994 → 06/2003</b>		
Dust Cover Kit, shock absorber	All Models		<b>AK-735037</b>		
Engine Mounting	2.0, 2.0 16V, 2.2 16V		<b>F7-2059</b>		Outer Thread 1 [mm]=M10 x 1,50 RHT M; Outer Thread 2 [mm]=M10 x 1,50 RHT M
Top Strut Mounting	2.0, 2.0 16V, 2.2 16V		<b>F8-4100</b>		H2=55; d=16; D1=96; D2=102
Control Arm-/Trailing Arm Bush	2.0, 2.0 16V, 2.0 DTI 16V, 2.2 16V, 2.5 TD, 2.5 V6, 3.0 V6		<b>F8-5337</b>		d=19; D=100
Belt Pulley, crankshaft	2.0 DTI 16V, 2.2 DTI 16V		<b>F8-5639</b>		
Control Arm-/Trailing Arm Bush	2.0, 2.0 16V, 2.0 DTI 16V, 2.2 16V, 2.2 DTI 16V, 2.5 V6, 2.6 V6, 3.0 V6, 3.2 V6		<b>F8-5722</b>		H=71; d=12; D=43
Mounting, axle beam	2.0, 2.0 16V, 2.0 DTI 16V, 2.2 16V, 2.2 DTI 16V, 2.5 V6, 2.6 V6, 3.0 V6, 3.2 V6		<b>F8-5911</b>		H=59; D=47.5
Stabiliser Mounting	2.0, 2.0 16V, 2.0 DTI 16V, 2.2 16V, 2.2 DTI 16V, 2.5 V6, 2.6 V6, 3.0 V6, 3.2 V6		<b>F8-5970</b>		H=29; D1=32; D2=29
Stabiliser Mounting	2.0, 2.0 16V, 2.0 DTI 16V, 2.2 16V, 2.2 DTI 16V, 2.5 V6, 2.6 V6, 3.0 V6, 3.2 V6		<b>F8-6091</b>		d=23; L=40
Top Strut Mounting	2.0 16V, 2.0 DTI 16V, 2.2 DTI 16V, 2.5 DTI 24V, 2.5 TD, 2.5 V6, 2.6 V6, 3.0 V6, 3.2 V6		<b>F8-6324</b>		
Idler Arm	2.0, 2.0 16V, 2.0 DTI 16V, 2.2 16V, 2.2 DTI 16V, 2.5 V6, 2.6 V6, 3.0 V6, 3.2 V6		<b>F8-6659</b>		d=18; L=110
Joint, propshaft	2.0, 2.0 16V		<b>F8-6766</b>		Bolt Hole Circle Ø [mm]=78; d=40; D=109
Engine Mounting	2.5 V6, 3.0 V6	ch.R1127219→; ch.→11125192	<b>F8-7850</b>		Outer Thread 1 [mm]=M10 x 1,50 RHT M; Outer Thread 2 [mm]=M10 x 1,50 RHT M

<b>AK-735037</b>	<b>F7-2059</b>	<b>F8-4100</b>	<b>F8-5337</b>	<b>F8-5639</b>	<b>F8-5722</b>	<b>F8-5911</b>
Ref.Nr.:	Ref.Nr.: 24417107	Ref.Nr.: 344511	Ref.Nr.: 90447156	Ref.Nr.: 0614411	Ref.Nr.: 0423315	Ref.Nr.: 0402649
<b>F8-5970</b>	<b>F8-6091</b>	<b>F8-6324</b>	<b>F8-6659</b>	<b>F8-6766</b>	<b>F8-7850</b>	<b>F8-7879</b>
Ref.Nr.: 0444347	Ref.Nr.: 0350147	Ref.Nr.: 90251358	Ref.Nr.: 920355	Ref.Nr.: 0458364	Ref.Nr.: 5682505	Ref.Nr.: 9266153

<b>Article Description</b>			<b>Article Nr.</b>	<b>Fitting Position</b>	
----------------------------	--	--	--------------------	-------------------------	--

<b>OMEGA (B) Estate</b>			<b>02/1994 → 06/2003</b>		
Engine Mounting	2.6 V6, 3.2 V6	ch.11125193→	<b>F8-7850</b>	⊕ ⊕	Outer Thread 1 [mm]=M10 x 1,50 RHT M; Outer Thread 2 [mm]=M10 x 1,50 RHT M
Engine Mounting	2.5 DTI 24V	Paired article nr: F8-6499	<b>F8-7879</b>	⊕	
<b>ROYALE</b>			<b>02/1978 → 08/1987</b>		
Dust Cover Kit, shock absorber	All Models		<b>AK-735005</b>	⊕ ⊕ ⊕	
<b>ROYALE Coupe</b>			<b>02/1978 → 08/1986</b>		
Dust Cover Kit, shock absorber	All Models		<b>AK-735005</b>	⊕ ⊕ ⊕	
<b>SENATOR</b>			<b>09/1984 → 08/1987</b>		
Dust Cover Kit, shock absorber	2.5 i, 3.0 i		<b>AK-735005</b>	⊕ ⊕ ⊕	
<b>SENATOR Mk II (B)</b>			<b>09/1987 → 09/1993</b>		
Anti-Friction Bearing	2.5 i, 2.6 i, 3.0, 3.0 24V, 3.0 i CAT		<b>F8-3024</b>	⊕ ⊕ ⊕	H=12; d=63; D=86
Control Arm-/Trailing Arm Bush	2.5 i, 2.6 i, 3.0, 3.0 24V, 3.0 i CAT		<b>F8-4097</b>	⊕ ⊕ ⊕	H1=26; H2=69; d=16; D1=27; D2=60
Control Arm-/Trailing Arm Bush	2.5 i, 2.6 i, 3.0, 3.0 24V, 3.0 i CAT		<b>F8-4098</b>	⊕ ⊕ ⊕ ↓	H=59; d=12; D1=33; D2=46
Top Strut Mounting	2.5 i, 2.6 i, 3.0, 3.0 i CAT		<b>F8-4100</b>	⊕ ⊕ ⊕	H2=55; d=16; D1=96; D2=102
Mounting, alternator	3.0, 3.0 i CAT	ch.→L1999999	<b>F8-5366</b>		
Control Arm-/Trailing Arm Bush	2.6 i, 3.0, 3.0 24V, 3.0 i CAT		<b>F8-5722</b>	⊕ ⊕ ⊕	H=71; d=12; D=43
Stabiliser Mounting	2.6 i, 3.0, 3.0 24V, 3.0 i CAT		<b>F8-5724</b>	⊕ ⊕ ⊕	d=14
Rubber Buffer, suspension	3.0, 3.0 24V, 3.0 i CAT		<b>F8-5964</b>	⊕ ⊕ ⊕	H=62; d=29
Top Strut Mounting	All Models		<b>F8-6324</b>		
Joint, propshaft	2.6 i, 3.0, 3.0 24V, 3.0 i CAT		<b>F8-6765</b>		d=50; D=127
<b>SIGNUM</b>			<b>03/2003 → 10/2008</b>		
Dust Cover Kit, shock absorber	1.9 CDTi, 1.9 CDTi 16V, 2.0 DTI, 2.0 i Turbo, 2.2 DTI, 2.2 i, 2.8 V6 Turbo, 3.0 CDTi, 3.0 V6 CDTi, 3.2 V6	<b>ST</b>	<b>AK-735251</b>	⊕ ⊕ ⊕	
Alternator Freewheel Clutch	2.0 i Turbo, 2.2 i		<b>F5-1079</b>		
Alternator Freewheel Clutch	1.9 CDTi, 1.9 CDTi 16V		<b>F5-1102</b>		
Alternator Freewheel Clutch	1.9 CDTi, 1.9 CDTi 16V		<b>F5-1123</b>		
Belt Pulley, crankshaft	2.0 DTI, 2.2 DTI		<b>F8-5639</b>		
Control Arm-/Trailing Arm Bush	1.8, 1.9 CDTi, 1.9 CDTi 16V, 2.0 DTI, 2.0 i Turbo, 2.2 DTI, 2.2 i, 2.8 V6 Turbo, 3.0 CDTi, 3.0 V6 CDTi, 3.2 V6		<b>F8-6447</b>	⊕ ⊕ ⊕ ↓	
Anti-Friction Bearing	1.8, 1.9 CDTi, 1.9 CDTi 16V, 2.0 DTI, 2.0 i Turbo, 2.2 DTI, 2.2 i, 2.8 V6 Turbo, 3.0 CDTi, 3.0 V6 CDTi, 3.2 V6		<b>F8-7172</b>	⊕ ⊕ ⊕	
Top Strut Mounting	1.8, 1.9 CDTi, 1.9 CDTi 16V, 2.0 DTI, 2.0 i Turbo, 2.2 DTI, 2.2 i, 2.8 V6 Turbo, 3.0 CDTi, 3.0 V6 CDTi, 3.2 V6		<b>F8-7329</b>	⊕ ⊕ ⊕	

<b>AK-735005</b>	<b>AK-735251</b>	<b>F5-1079</b>	<b>F5-1102</b>	<b>F5-1123</b>	<b>F8-3024</b>	<b>F8-4097</b>
Ref.Nr.:	Ref.Nr.: 344435	Ref.Nr.: 1204376	Ref.Nr.: 1204151	Ref.Nr.: 9948513	Ref.Nr.: 90121275	Ref.Nr.: 352355
<b>F8-4098</b>	<b>F8-4100</b>	<b>F8-5366</b>	<b>F8-5639</b>	<b>F8-5722</b>	<b>F8-5724</b>	<b>F8-5964</b>
Ref.Nr.: 90279193	Ref.Nr.: 344511	Ref.Nr.: 1204885	Ref.Nr.: 0614411	Ref.Nr.: 0423315	Ref.Nr.: 0444153	Ref.Nr.: 0344409
<b>F8-6324</b>	<b>F8-6447</b>	<b>F8-6765</b>	<b>F8-7172</b>	<b>F8-7329</b>	<b>F8-7330</b>	<b>F8-7850</b>
Ref.Nr.: 90251358	Ref.Nr.: 12786412	Ref.Nr.: 458367	Ref.Nr.: 9191181	Ref.Nr.: 344529	Ref.Nr.: 344537	Ref.Nr.: 5682505

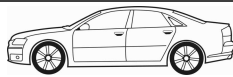
**Article Description****Article Nr.****Fitting Position**

<b>SIGNUM</b>		<b>03/2003 → 10/2008</b>	
Top Strut Mounting	1.8, 1.9 CDTi, 1.9 CDTi 16V, 2.0 DTi, 2.0 i Turbo, 2.2 DTi, 2.2 i, 2.8 V6 Turbo, 3.0 CDTi, 3.0 V6 CDTi, 3.2 V6	F8-7330	
Control Arm-/Trailing Arm Bush	1.8, 1.9 CDTi, 1.9 CDTi 16V, 2.0 DTi, 2.0 i Turbo, 2.2 DTi, 2.2 i, 2.8 V6 Turbo, 3.0 CDTi, 3.0 V6 CDTi, 3.2 V6	F8-7373	d=12; L=52; L1=32; D=45.5
Rubber Buffer, suspension	1.9 Turbo	ch.52000001, 55000001, 58000001→;	F8-7662  H=40
Rubber Buffer, suspension	1.9 Turbo		F8-7662  H=40
Protective Cap/Bellow, shock absorber	1.8, 1.9 CDTi, 1.9 CDTi 16V, 1.9 Turbo, 2.0 DTi, 2.0 i Turbo, 2.2 DTi, 2.2 i, 2.8 V6 Turbo, 3.0 CDTi, 3.0 V6 CDTi, 3.2 V6	F8-7663	H=205
Rubber Buffer, suspension	1.8, 1.9 CDTi, 1.9 CDTi 16V, 2.0 DTi, 2.0 i Turbo, 2.2 DTi, 2.2 i, 2.8 V6 Turbo, 3.0 CDTi, 3.0 V6 CDTi, 3.2 V6	F8-7699	H=50
Rubber Buffer, suspension	1.9 Turbo	ch.→4299999, 4599999, 4899999;	F8-7699  H=50
Rubber Buffer, suspension	1.9 Turbo	ch.52000001, 55000001, 58000001→;	F8-7699  H=50
Stabiliser Mounting	1.8, 1.9 CDTi, 1.9 CDTi 16V, 2.0 DTi, 2.0 i Turbo, 2.2 DTi, 2.2 i, 2.8 V6 Turbo, 3.0 CDTi, 3.0 V6 CDTi, 3.2 V6	F8-7919	d=17
Mounting, automatic transmission	1.9 CDTi 16V, 2.0 DTi, 2.2 DTi	F8-8170	
<b>SINTRA</b>		<b>11/1996 → 04/1999</b>	
Dust Cover Kit, shock absorber	All Models	AK-735254	
Dust Cover Kit, shock absorber	All Models	AK-735255	
Belt Pulley, crankshaft	2.2 DTi	01/1999 →	F8-5639
Anti-Friction Bearing	All Models	F8-7632	
<b>TIGRA Mk I (F07)</b>		<b>07/1994 → 12/2000</b>	
Dust Cover Kit, shock absorber	All Models	01/1995 →	AK-735003
Anti-Friction Bearing	All Models		F8-3024  H=12; d=63; D=86
Top Strut Mounting	All Models		F8-4100  H2=55; d=16; D1=96; D2=102
Tie Bar Bush	All Models	ch.→V3023597, V4166925, V6066279	F8-5128  H=40; d=14; D=36, 50
Engine Mounting	All Models		F8-5373
Top Strut Mounting	All Models		F8-5450
Control Arm-/Trailing Arm Bush	All Models		F8-5552  d=10; L=65; D=42
Tie Bar Bush	All Models	ch.→3023597, 4166925, 6066279	F8-6037
Tie Bar Bush	All Models	ch.→6066279	F8-6038
Top Strut Mounting	All Models		F8-6319
Rubber Buffer, suspension	All Models		F8-6517
Engine Mounting	All Models		F8-8166

<b>AK-735003</b>	<b>AK-735254</b>	<b>AK-735255</b>	<b>F8-3024</b>	<b>F8-4100</b>	<b>F8-5128</b>	<b>F8-5373</b>
Ref.Nr.:	Ref.Nr.: 344645	Ref.Nr.: 434030	Ref.Nr.: 90121275	Ref.Nr.: 344511	Ref.Nr.: 90445098	Ref.Nr.: 0684666
<b>F8-5450</b>	<b>F8-5552</b>	<b>F8-5639</b>	<b>F8-6037</b>	<b>F8-6038</b>	<b>F8-6319</b>	<b>F8-6517</b>
Ref.Nr.: 0344519	Ref.Nr.: 90217845	Ref.Nr.: 0614411	Ref.Nr.: 0353281	Ref.Nr.: 0353280	Ref.Nr.: 0312503	Ref.Nr.: 90468618
<b>F8-7330</b>	<b>F8-7373</b>	<b>F8-7632</b>	<b>F8-7662</b>	<b>F8-7663</b>	<b>F8-7699</b>	<b>F8-7919</b>
Ref.Nr.: 344537	Ref.Nr.: 24469643	Ref.Nr.: 908554	Ref.Nr.: 0344956	Ref.Nr.: 344435	Ref.Nr.: 13117280	Ref.Nr.: 444160

<b>Article Description</b>			<b>Article Nr.</b>	<b>Fitting Position</b>	
----------------------------	--	--	--------------------	-------------------------	--

<b>TIGRA Mk I (F07)</b>				<b>07/1994 → 12/2000</b>	
Control Arm-/Trailing Arm Bush	All Models		<b>G9-590</b>		H=52; d1=10; d2=14; D1=38; D2=45
<b>TIGRA TwinTop</b>				<b>06/2004 → 08/2009</b>	
Alternator Freewheel Clutch	1.3 CDTI		<b>F5-1041</b>		
Alternator Freewheel Clutch	1.3 CDTI		<b>F5-1045</b>		
Control Arm-/Trailing Arm Bush	All Models		<b>F8-5262</b>		
Top Strut Mounting	1.4, 1.8	Bearing Type: Soft Version;	<b>F8-5448</b>		
Rubber Buffer, suspension	All Models		<b>F8-6517</b>		
Engine Mounting	All Models		<b>F8-6753</b>		
Rubber Buffer, suspension	All Models		<b>F8-7698</b>		H=63
Engine Mounting	1.4		<b>F8-7793</b>		
Engine Mounting	1.4		<b>F8-7794</b>		
Engine Mounting	1.4, 1.8		<b>F8-8158</b>		
Engine Mounting	1.4, 1.8		<b>F8-8161</b>		
<b>VECTRA (B)</b>				<b>08/1995 → 03/2002</b>	
Rubber Buffer, suspension	1.6 i, 1.6 i 16V, 1.7 TD, 1.8 i 16V, 2.0 DI 16V, 2.0 DTI 16V, 2.0 i 16V, 2.2 DTI 16V, 2.2 i 16V, 2.5 i GSi, 2.5 i V6, 2.6 i V6		<b>AK-735038</b>		
Dust Cover Kit, shock absorber	1.6 i, 1.6 i 16V, 1.7 TD, 1.8 i 16V, 2.0 DI 16V, 2.0 DTI 16V, 2.0 i 16V, 2.2 DTI 16V, 2.2 i 16V, 2.5 i GSi, 2.5 i V6, 2.6 i V6	ch.T1086824→	<b>AK-735138</b>		
Alternator Freewheel Clutch	1.6 i 16V		<b>F5-1050</b>		
Mounting, axle beam	1.6 i, 1.6 i 16V, 1.7 TD, 1.8 i 16V, 2.0 DI 16V, 2.0 DTI 16V, 2.0 i 16V, 2.2 DTI 16V, 2.2 i 16V, 2.5 i GSi, 2.5 i V6, 2.6 i V6		<b>F8-3060</b>		H=75; d=12; D1=49; D2=57
Control Arm-/Trailing Arm Bush	1.6 i, 1.6 i 16V, 1.7 TD, 1.8 i 16V, 2.0 DI 16V, 2.0 DTI 16V, 2.0 i 16V, 2.2 DTI 16V, 2.2 i 16V, 2.5 i GSi, 2.5 i V6, 2.6 i V6		<b>F8-4090</b>		H1=50; H2=59; d=12; D1=36; D2=43
Control Arm-/Trailing Arm Bush	1.6 i, 1.6 i 16V, 1.7 TD, 1.8 i 16V, 2.0 DI 16V, 2.0 DTI 16V, 2.0 i 16V, 2.2 DTI 16V, 2.2 i 16V, 2.5 i GSi, 2.5 i V6, 2.6 i V6		<b>F8-5110</b>		H=61; d=12; D=47.5
Control Arm-/Trailing Arm Bush	1.6 i, 1.6 i 16V, 1.7 TD, 1.8 i 16V, 2.0 DI 16V, 2.0 DTI 16V, 2.0 i 16V, 2.2 DTI 16V, 2.2 i 16V, 2.5 i GSi, 2.5 i V6, 2.6 i V6		<b>F8-5201</b>		d=12; D=45; W=52
Buffer, engine mounting	1.6 i, 1.6 i 16V, 1.8 i 16V, 2.0 i 16V		<b>F8-5367</b>		
Engine Mounting	1.6 i, 1.6 i 16V, 1.8 i 16V		<b>F8-5370</b>		
Top Strut Mounting	1.6 i, 1.6 i 16V, 1.7 TD, 1.8 i 16V	Bearing Type: Soft Version;	<b>F8-5448</b>		
Top Strut Mounting	2.0 DI 16V, 2.0 DTI 16V, 2.0 i 16V, 2.2 DTI 16V, 2.2 i 16V, 2.5 i GSi, 2.5 i V6, 2.6 i V6		<b>F8-5463</b>		
Belt Pulley, crankshaft	2.0 DI 16V, 2.0 DTI 16V, 2.2 DTI 16V		<b>F8-5639</b>		

<b>AK-735038</b>	<b>AK-735138</b>	<b>F5-1041</b>	<b>F5-1045</b>	<b>F5-1050</b>	<b>F8-3060</b>	<b>F8-4090</b>
Ref.Nr.: 344417	Ref.Nr.:	Ref.Nr.: 77364723	Ref.Nr.: 77362721	Ref.Nr.: 1204412	Ref.Nr.: 90189050	Ref.Nr.: 4566899
<b>F8-5110</b>	<b>F8-5201</b>	<b>F8-5262</b>	<b>F8-5367</b>	<b>F8-5370</b>	<b>F8-5448</b>	<b>F8-5463</b>
Ref.Nr.: 0352358	Ref.Nr.: 423121	Ref.Nr.: 13138151	Ref.Nr.: 0684703	Ref.Nr.: 0684670	Ref.Nr.: 0344523	Ref.Nr.: 0344525
<b>F8-5639</b>	<b>F8-5721</b>	<b>F8-6517</b>	<b>F8-6753</b>	<b>F8-7698</b>	<b>F8-7793</b>	<b>F8-7794</b>
Ref.Nr.: 0614411	Ref.Nr.: 436955	Ref.Nr.: 90468618	Ref.Nr.: 0684238	Ref.Nr.: 24403535	Ref.Nr.: 13125209	Ref.Nr.: 13125208

**Article Description****Article Nr.****Fitting Position**

<b>VECTRA (B)</b>			<b>08/1995 → 03/2002</b>		
Rubber Buffer, suspension	1.6 i, 1.6 i 16V, 1.7 TD, 1.8 i 16V, 2.0 DI 16V, 2.0 DTI 16V, 2.0 i 16V, 2.2 DTI 16V, 2.2 i 16V, 2.5 i GSi, 2.5 i V6, 2.6 i V6	ch.T1086824→	<b>F8-5721</b>		H=113
Control Arm-/Trailing Arm Bush	1.6 i, 1.6 i 16V, 1.7 TD, 1.8 i 16V, 2.0 DI 16V, 2.0 DTI 16V, 2.0 i 16V, 2.2 DTI 16V, 2.2 i 16V, 2.5 i GSi, 2.5 i V6, 2.6 i V6		<b>F8-5723</b>		H=89; d=12; D=35
Stabiliser Mounting	1.6 i 16V		<b>F8-5724</b>		d=14
Rubber Buffer, suspension	1.6 i, 1.6 i 16V, 1.7 TD, 1.8 i 16V, 2.0 DI 16V, 2.0 DTI 16V, 2.0 i 16V, 2.2 DTI 16V, 2.2 i 16V, 2.5 i GSi, 2.5 i V6, 2.6 i V6		<b>F8-5878</b>		H=62.5; d=24; D=50
Rubber Buffer, suspension	1.6 i, 1.6 i 16V, 1.7 TD, 1.8 i 16V, 2.0 DI 16V, 2.0 DTI 16V, 2.0 i 16V, 2.2 DTI 16V, 2.2 i 16V, 2.5 i GSi, 2.5 i V6, 2.6 i V6	ch.→T1086823	<b>F8-5912</b>		H=141
Rubber Buffer, suspension	1.6 i, 1.6 i 16V, 1.7 TD, 1.8 i 16V, 2.0 DI 16V, 2.0 DTI 16V, 2.0 i 16V, 2.2 DTI 16V, 2.2 i 16V, 2.5 i GSi, 2.5 i V6, 2.6 i V6		<b>F8-5966</b>		H=53; d=24; D=50
Control Arm-/Trailing Arm Bush	1.6 i, 1.6 i 16V, 1.7 TD, 1.8 i 16V, 2.0 DI 16V, 2.0 DTI 16V, 2.0 i 16V, 2.2 DTI 16V, 2.2 i 16V, 2.5 i GSi, 2.5 i V6, 2.6 i V6		<b>F8-6098</b>		H=55; d=12; D=60
Rubber Buffer, suspension	1.6 i, 1.6 i 16V, 1.7 TD, 1.8 i 16V, 2.0 DI 16V, 2.0 DTI 16V, 2.0 i 16V, 2.2 DTI 16V, 2.2 i 16V, 2.5 i GSi, 2.5 i V6, 2.6 i V6		<b>F8-6517</b>		
Stabiliser Mounting	1.6 i 16V	ch.X1000001, X7000001→;  X 16 XEL	<b>F8-6660</b>		d=16
Stabiliser Mounting	1.6 i, 1.8 i 16V	ch.X1000001, X7000001→	<b>F8-6660</b>		d=16
Stabiliser Mounting	1.7 TD, 2.0 i 16V, 2.5 i V6		<b>F8-6660</b>		d=16
Stabiliser Mounting	1.8 i 16V	ch.→W1999999, W5999999, W7999999;  X 18 XE1	<b>F8-6660</b>		d=16
Stabiliser Mounting	2.0 DI 16V	ch.→W1999999, W5999999, W7999999	<b>F8-6660</b>		d=16
Stabiliser Mounting	2.0 DTI 16V	ch.→W1999999, W5999999, W7999999;  X 20 DTH	<b>F8-6660</b>		d=16
Mounting, automatic transmission	1.6 i, 1.6 i 16V, 1.8 i 16V, 2.0 DI 16V, 2.0 DTI 16V, 2.2 i 16V		<b>F8-6739</b>		
Mounting, automatic transmission	1.8 i 16V, 2.0 i 16V		<b>F8-6740</b>		
Engine Mounting	2.0 DI 16V, 2.0 DTI 16V		<b>F8-8183</b>		
Bellow, steering	1.6 i, 1.6 i 16V, 1.7 TD, 1.8 i 16V, 2.0 DI 16V, 2.0 DTI 16V, 2.0 i 16V, 2.2 DTI 16V, 2.2 i 16V, 2.5 i GSi, 2.5 i V6, 2.6 i V6	for steering gear manufacturer: ZF; with clamps	<b>LM-10030S</b>		d1=14; d2=48; L [mm]=158
Bellow, steering	1.6 i, 1.6 i 16V, 1.7 TD, 1.8 i 16V, 2.0 DI 16V, 2.0 DTI 16V, 2.0 i 16V, 2.2 DTI 16V, 2.2 i 16V, 2.5 i GSi, 2.5 i V6, 2.6 i V6	with clamps	<b>LM-10059S</b>		d1=13; d2=49; L [mm]=166

<b>AK-735038</b>	<b>F8-5721</b>	<b>F8-5723</b>	<b>F8-5724</b>	<b>F8-5878</b>	<b>F8-5912</b>	<b>F8-5966</b>
Ref.Nr.: 344417	Ref.Nr.: 436955	Ref.Nr.: 0423316	Ref.Nr.: 0444153	Ref.Nr.: 0344417	Ref.Nr.: 0436933	Ref.Nr.: 0344418
<b>F8-6098</b>	<b>F8-6517</b>	<b>F8-6660</b>	<b>F8-6739</b>	<b>F8-6740</b>	<b>F8-8183</b>	<b>LM-10030S</b>
Ref.Nr.: 0423302	Ref.Nr.: 90468618	Ref.Nr.: 90496706	Ref.Nr.: 90495513	Ref.Nr.: 5682508	Ref.Nr.: 684684	Ref.Nr.: 90512778
<b>LM-10059S</b>						
Ref.Nr.: 520738						

Article Description



Article Nr.

Fitting Position



**VECTRA (B) Hatchback**

08/1995 → 07/2003

Rubber Buffer, suspension	1.6 i, 1.6 i 16V, 1.7 TD, 1.8 i 16V, 2.0 Di 16V, 2.0 DTi 16V, 2.0 i 16V, 2.2 DTi 16V, 2.2 i 16V, 2.5 i GSi, 2.5 i V6, 2.6 i V6		<b>AK-735038</b>		
Dust Cover Kit, shock absorber	1.6 i, 1.6 i 16V, 1.7 TD, 1.8 i 16V, 2.0 Di 16V, 2.0 DTi 16V, 2.0 i 16V, 2.2 DTi 16V, 2.2 i 16V, 2.5 i GSi, 2.5 i V6, 2.6 i V6	ch.T1086824→	<b>AK-735138</b>		
Alternator Freewheel Clutch	1.6 i 16V		<b>F5-1050</b>		
Mounting, axle beam	1.6 i, 1.6 i 16V, 1.7 TD, 1.8 i 16V, 2.0 Di 16V, 2.0 DTi 16V, 2.0 i 16V, 2.2 DTi 16V, 2.2 i 16V, 2.5 i GSi, 2.5 i V6, 2.6 i V6		<b>F8-3060</b>		H=75; d=12; D1=49; D2=57
Control Arm-/Trailing Arm Bush	1.6 i, 1.6 i 16V, 1.7 TD, 1.8 i 16V, 2.0 Di 16V, 2.0 DTi 16V, 2.0 i 16V, 2.2 DTi 16V, 2.2 i 16V, 2.5 i GSi, 2.5 i V6, 2.6 i V6		<b>F8-4090</b>		H1=50; H2=59; d=12; D1=36; D2=43
Control Arm-/Trailing Arm Bush	1.6 i, 1.6 i 16V, 1.7 TD, 1.8 i 16V, 2.0 Di 16V, 2.0 DTi 16V, 2.0 i 16V, 2.2 DTi 16V, 2.2 i 16V, 2.5 i GSi, 2.5 i V6, 2.6 i V6		<b>F8-5110</b>		H=61; d=12; D=47.5
Control Arm-/Trailing Arm Bush	1.6 i, 1.6 i 16V, 1.7 TD, 1.8 i 16V, 2.0 Di 16V, 2.0 DTi 16V, 2.0 i 16V, 2.2 DTi 16V, 2.2 i 16V, 2.5 i GSi, 2.5 i V6, 2.6 i V6		<b>F8-5201</b>		d=12; D=45; W=52
Buffer, engine mounting	1.6 i, 1.6 i 16V, 1.8 i 16V, 2.0 i 16V		<b>F8-5367</b>		
Engine Mounting	1.6 i, 1.6 i 16V, 1.8 i 16V		<b>F8-5370</b>		
Top Strut Mounting	1.6 i, 1.6 i 16V, 1.7 TD, 1.8 i 16V	Bearing Type: Soft Version;	<b>F8-5448</b>		
Top Strut Mounting	2.0 Di 16V, 2.0 DTi 16V, 2.0 i 16V, 2.2 DTi 16V, 2.2 i 16V, 2.5 i GSi, 2.5 i V6, 2.6 i V6		<b>F8-5463</b>		
Belt Pulley, crankshaft	2.0 Di 16V, 2.0 DTi 16V, 2.2 DTi 16V		<b>F8-5639</b>		
Rubber Buffer, suspension	1.6 i, 1.6 i 16V, 1.7 TD, 1.8 i 16V, 2.0 Di 16V, 2.0 DTi 16V, 2.0 i 16V, 2.2 DTi 16V, 2.2 i 16V, 2.5 i GSi, 2.5 i V6, 2.6 i V6	ch.T1086824→	<b>F8-5721</b>		H=113
Control Arm-/Trailing Arm Bush	1.6 i, 1.6 i 16V, 1.7 TD, 1.8 i 16V, 2.0 Di 16V, 2.0 DTi 16V, 2.0 i 16V, 2.2 DTi 16V, 2.2 i 16V, 2.5 i GSi, 2.5 i V6, 2.6 i V6		<b>F8-5723</b>		H=89; d=12; D=35
Stabiliser Mounting	1.6 i 16V		<b>F8-5724</b>		d=14
Rubber Buffer, suspension	1.6 i, 1.6 i 16V, 1.7 TD, 1.8 i 16V, 2.0 Di 16V, 2.0 DTi 16V, 2.0 i 16V, 2.2 DTi 16V, 2.2 i 16V, 2.5 i GSi, 2.5 i V6, 2.6 i V6		<b>F8-5878</b>		H=62.5; d=24; D=50
Rubber Buffer, suspension	1.6 i, 1.6 i 16V, 1.7 TD, 1.8 i 16V, 2.0 Di 16V, 2.0 DTi 16V, 2.0 i 16V, 2.2 DTi 16V, 2.2 i 16V, 2.5 i GSi, 2.5 i V6, 2.6 i V6	ch.→T1086823	<b>F8-5912</b>		H=141
Rubber Buffer, suspension	1.6 i, 1.6 i 16V, 1.7 TD, 1.8 i 16V, 2.0 Di 16V, 2.0 DTi 16V, 2.0 i 16V, 2.2 DTi 16V, 2.2 i 16V, 2.5 i GSi, 2.5 i V6, 2.6 i V6		<b>F8-5966</b>		H=53; d=24; D=50
Control Arm-/Trailing Arm Bush	1.6 i, 1.6 i 16V, 1.7 TD, 1.8 i 16V, 2.0 Di 16V, 2.0 DTi 16V, 2.0 i 16V, 2.2 DTi 16V, 2.2 i 16V, 2.5 i GSi, 2.5 i V6, 2.6 i V6		<b>F8-6098</b>		H=55; d=12; D=60

<b>AK-735038</b>	<b>AK-735138</b>	<b>F5-1050</b>	<b>F8-3060</b>	<b>F8-4090</b>	<b>F8-5110</b>	<b>F8-5201</b>
Ref.Nr.: 344417	Ref.Nr.:	Ref.Nr.: 1204412	Ref.Nr.: 90189050	Ref.Nr.: 4566899	Ref.Nr.: 0352358	Ref.Nr.: 423121
<b>F8-5367</b>	<b>F8-5370</b>	<b>F8-5448</b>	<b>F8-5463</b>	<b>F8-5639</b>	<b>F8-5721</b>	<b>F8-5723</b>
Ref.Nr.: 0684703	Ref.Nr.: 0684670	Ref.Nr.: 0344523	Ref.Nr.: 0344525	Ref.Nr.: 0614411	Ref.Nr.: 436955	Ref.Nr.: 0423316
<b>F8-5724</b>	<b>F8-5878</b>	<b>F8-5912</b>	<b>F8-5966</b>	<b>F8-6098</b>	<b>F8-6517</b>	
Ref.Nr.: 0444153	Ref.Nr.: 0344417	Ref.Nr.: 0436933	Ref.Nr.: 0344418	Ref.Nr.: 0423302	Ref.Nr.: 90468618	



Article Description

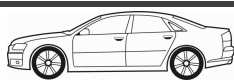

Article Nr.

Fitting Position



### VECTRA (B) Hatchback 08/1995 → 07/2003

Rubber Buffer, suspension	1.6 i, 1.6 i 16V, 1.7 TD, 1.8 i 16V, 2.0 Di 16V, 2.0 DTi 16V, 2.0 i 16V, 2.2 DTi 16V, 2.2 i 16V, 2.5 i GSi, 2.5 i V6, 2.6 i V6		<b>F8-6517</b>		
Stabiliser Mounting	1.6 i 16V	ch.X1000001, X7000001→;  X 16 XEL	<b>F8-6660</b>		d=16
Stabiliser Mounting	1.6 i, 1.8 i 16V	ch.X1000001, X7000001→	<b>F8-6660</b>		d=16
Stabiliser Mounting	1.7 TD, 2.0 i 16V, 2.5 i V6		<b>F8-6660</b>		d=16
Stabiliser Mounting	1.8 i 16V	ch.→W1999999, W5999999, W7999999;  X 18 XE1	<b>F8-6660</b>		d=16
Stabiliser Mounting	2.0 Di 16V	ch.→W1999999, W5999999, W7999999	<b>F8-6660</b>		d=16
Stabiliser Mounting	2.0 DTi 16V	ch.→W1999999, W5999999, W7999999;  X 20 DTH	<b>F8-6660</b>		d=16
Mounting, automatic transmission	1.6 i, 1.6 i 16V, 1.8 i 16V, 2.0 Di 16V, 2.0 DTi 16V, 2.2 i 16V		<b>F8-6739</b>		
Mounting, automatic transmission	1.8 i 16V, 2.0 i 16V		<b>F8-6740</b>		
Engine Mounting	2.0 Di 16V, 2.0 DTi 16V		<b>F8-8183</b>		
Bellow, steering	1.6 i, 1.6 i 16V, 1.7 TD, 1.8 i 16V, 2.0 Di 16V, 2.0 DTi 16V, 2.0 i 16V, 2.2 DTi 16V, 2.2 i 16V, 2.5 i GSi, 2.5 i V6, 2.6 i V6	for steering gear manufacturer: ZF; with clamps	<b>LM-10030S</b>		d1=14; d2=48; L [mm]=158
Bellow, steering	1.6 i, 1.6 i 16V, 1.7 TD, 1.8 i 16V, 2.0 Di 16V, 2.0 DTi 16V, 2.0 i 16V, 2.2 DTi 16V, 2.2 i 16V, 2.5 i GSi, 2.5 i V6, 2.6 i V6	with clamps	<b>LM-10059S</b>		d1=13; d2=49; L [mm]=166

### VECTRA (B) Estate 08/1995 → 03/2002

Rubber Buffer, suspension	1.6 i, 1.6 i 16V, 1.8 i 16V, 2.0 Di 16V, 2.0 DTi 16V, 2.0 i 16V, 2.2 DTi 16V, 2.2 i 16V, 2.5 i GSi, 2.5 i V6, 2.6 i V6		<b>AK-735038</b>		
Dust Cover Kit, shock absorber	1.6 i, 1.6 i 16V, 1.8 i 16V, 2.0 Di 16V, 2.0 DTi 16V, 2.0 i 16V, 2.2 DTi 16V, 2.2 i 16V, 2.5 i GSi, 2.5 i V6, 2.6 i V6	ch.T1086824→	<b>AK-735138</b>		
Alternator Freewheel Clutch	1.6 i 16V		<b>F5-1050</b>		
Mounting, axle beam	1.6 i, 1.6 i 16V, 1.8 i 16V, 2.0 Di 16V, 2.0 DTi 16V, 2.0 i 16V, 2.2 DTi 16V, 2.2 i 16V, 2.5 i GSi, 2.5 i V6, 2.6 i V6		<b>F8-3060</b>		H=75; d=12; D1=49; D2=57
Control Arm-/Trailing Arm Bush	1.6 i, 1.6 i 16V, 1.8 i 16V, 2.0 Di 16V, 2.0 DTi 16V, 2.0 i 16V, 2.2 DTi 16V, 2.2 i 16V, 2.5 i GSi, 2.5 i V6, 2.6 i V6		<b>F8-4090</b>		H1=50; H2=59; d=12; D1=36; D2=43
Control Arm-/Trailing Arm Bush	1.6 i, 1.6 i 16V, 1.8 i 16V, 2.0 Di 16V, 2.0 DTi 16V, 2.0 i 16V, 2.2 DTi 16V, 2.2 i 16V, 2.5 i GSi, 2.5 i V6, 2.6 i V6		<b>F8-5110</b>		H=61; d=12; D=47.5
Control Arm-/Trailing Arm Bush	1.6 i, 1.6 i 16V, 1.7 TD, 1.8 i 16V, 2.0 Di 16V, 2.0 DTi 16V, 2.0 i 16V, 2.2 DTi 16V, 2.2 i 16V, 2.5 i GSi, 2.5 i V6, 2.6 i V6		<b>F8-5201</b>		d=12; D=45; W=52
Buffer, engine mounting	1.6 i, 1.6 i 16V, 1.8 i 16V, 2.0 i 16V		<b>F8-5367</b>		
Engine Mounting	1.6 i, 1.6 i 16V, 1.8 i 16V		<b>F8-5370</b>		

<b>AK-735038</b>	<b>AK-735138</b>	<b>F5-1050</b>	<b>F8-3060</b>	<b>F8-4090</b>	<b>F8-5110</b>	<b>F8-5201</b>
Ref.Nr.: 344417	Ref.Nr.:	Ref.Nr.: 1204412	Ref.Nr.: 90189050	Ref.Nr.: 4566899	Ref.Nr.: 0352358	Ref.Nr.: 423121
<b>F8-5367</b>	<b>F8-5370</b>	<b>F8-5448</b>	<b>F8-6517</b>	<b>F8-6660</b>	<b>F8-6739</b>	<b>F8-6740</b>
Ref.Nr.: 0684703	Ref.Nr.: 0684670	Ref.Nr.: 0344523	Ref.Nr.: 90468618	Ref.Nr.: 90496706	Ref.Nr.: 90495513	Ref.Nr.: 5682508
<b>F8-8183</b>	<b>LM-10030S</b>	<b>LM-10059S</b>				
Ref.Nr.: 684684	Ref.Nr.: 90512778	Ref.Nr.: 520738				

Article Description



Article Nr.

Fitting Position



**VECTRA (B) Estate**

08/1995 → 03/2002

Top Strut Mounting	1.6 i, 1.6 i 16V, 1.8 i 16V	Bearing Type: Soft Version;	<b>F8-5448</b>		
Top Strut Mounting	2.0 DI 16V, 2.0 DTI 16V, 2.0 i 16V, 2.2 DTI 16V, 2.2 i 16V, 2.5 i GSi, 2.5 i V6, 2.6 i V6		<b>F8-5463</b>		
Belt Pulley, crankshaft	2.0 DI 16V, 2.0 DTI 16V, 2.2 DTI 16V		<b>F8-5639</b>		
Rubber Buffer, suspension	1.6 i, 1.6 i 16V, 1.8 i 16V, 2.0 DI 16V, 2.0 DTI 16V, 2.0 i 16V, 2.2 DTI 16V, 2.2 i 16V, 2.5 i GSi, 2.5 i V6, 2.6 i V6	ch.T1086824→	<b>F8-5721</b>		H=113
Control Arm-/Trailing Arm Bush	1.6 i, 1.6 i 16V, 1.8 i 16V, 2.0 DI 16V, 2.0 DTI 16V, 2.0 i 16V, 2.2 DTI 16V, 2.2 i 16V, 2.5 i GSi, 2.5 i V6, 2.6 i V6		<b>F8-5723</b>		H=89; d=12; D=35
Stabiliser Mounting	1.6 i 16V		<b>F8-5724</b>		d=14
Rubber Buffer, suspension	1.6 i, 1.6 i 16V, 1.8 i 16V, 2.0 DI 16V, 2.0 DTI 16V, 2.0 i 16V, 2.2 DTI 16V, 2.2 i 16V, 2.5 i GSi, 2.5 i V6, 2.6 i V6		<b>F8-5878</b>		H=62.5; d=24; D=50
Rubber Buffer, suspension	1.6 i, 1.6 i 16V, 1.8 i 16V, 2.0 DI 16V, 2.0 DTI 16V, 2.0 i 16V, 2.2 DTI 16V, 2.2 i 16V, 2.5 i GSi, 2.5 i V6, 2.6 i V6	ch.→T1086823	<b>F8-5912</b>		H=141
Rubber Buffer, suspension	1.6 i, 1.6 i 16V, 1.8 i 16V, 2.0 DI 16V, 2.0 DTI 16V, 2.0 i 16V, 2.2 DTI 16V, 2.2 i 16V, 2.5 i GSi, 2.5 i V6, 2.6 i V6		<b>F8-5966</b>		H=53; d=24; D=50
Control Arm-/Trailing Arm Bush	1.6 i, 1.6 i 16V, 1.8 i 16V, 2.0 DI 16V, 2.0 DTI 16V, 2.0 i 16V, 2.2 DTI 16V, 2.2 i 16V, 2.5 i GSi, 2.5 i V6, 2.6 i V6		<b>F8-6098</b>		H=55; d=12; D=60
Rubber Buffer, suspension	1.6 i, 1.6 i 16V, 1.8 i 16V, 2.0 DI 16V, 2.0 DTI 16V, 2.0 i 16V, 2.2 DTI 16V, 2.2 i 16V, 2.5 i GSi, 2.5 i V6, 2.6 i V6		<b>F8-6517</b>		
Stabiliser Mounting	1.6 i 16V	ch.X1000001, X7000001→;  X 16 XEL	<b>F8-6660</b>		d=16
Stabiliser Mounting	1.6 i, 1.8 i 16V	ch.X1000001, X7000001→	<b>F8-6660</b>		d=16
Stabiliser Mounting	1.8 i 16V	ch.→W1999999, W5999999, W7999999;  X 18 XE1	<b>F8-6660</b>		d=16
Stabiliser Mounting	2.0 DI 16V	ch.→W1999999, W5999999, W7999999	<b>F8-6660</b>		d=16
Stabiliser Mounting	2.0 DTI 16V	ch.→W1999999, W5999999, W7999999;  X 20 DTH	<b>F8-6660</b>		d=16
Stabiliser Mounting	2.0 i 16V, 2.5 i V6		<b>F8-6660</b>		d=16
Mounting, automatic transmission	1.6 i, 1.6 i 16V, 1.8 i 16V, 2.0 DI 16V, 2.0 DTI 16V, 2.2 i 16V		<b>F8-6739</b>		
Mounting, automatic transmission	1.8 i 16V, 2.0 i 16V		<b>F8-6740</b>		
Engine Mounting	2.0 DI 16V, 2.0 DTI 16V		<b>F8-8183</b>		
Bellow, steering	1.6 i, 1.6 i 16V, 1.8 i 16V, 2.0 DI 16V, 2.0 DTI 16V, 2.0 i 16V, 2.2 DTI 16V, 2.2 i 16V, 2.5 i GSi, 2.5 i V6, 2.6 i V6	for steering gear manufacturer: ZF; with clamps	<b>LM-10030S</b>		d1=14; d2=48; L [mm]=158
Bellow, steering	1.6 i 16V, 1.8 i 16V, 2.0 DI 16V, 2.0 DTI 16V, 2.0 i 16V, 2.2 DTI 16V, 2.2 i 16V, 2.5 i GSi, 2.5 i V6, 2.6 i V6	with clamps	<b>LM-10059S</b>		d1=13; d2=49; L [mm]=166





**Article Description****Article Nr.****Fitting Position**

<b>VECTRA Mk II (C)</b>		<b>01/2000 → 10/2008</b>	
Dust Cover Kit, shock absorber	1.6, 1.6 16V, 1.8, 1.8 16V, 1.8 16V Dualfuel, 1.9 CDTI, 1.9 CDTI 16V, 2.0 16V Turbo, 2.0 DTI 16V, 2.2 16V, 2.2 direct, 2.2 DTI 16V, 2.8 V6 Turbo, 3.0 CDTi, 3.0 V6 CDTI, 3.2 V6	ST	AK-735251
Alternator Freewheel Clutch	1.8, 1.8 16V, 1.8 16V Dualfuel		F5-1050
Alternator Freewheel Clutch	2.0 16V Turbo, 2.2 16V, 2.2 direct		F5-1079
Alternator Freewheel Clutch	1.9 CDTI, 1.9 CDTI 16V		F5-1102
Alternator Freewheel Clutch	1.9 CDTI, 1.9 CDTI 16V		F5-1123
Control Arm-/Trailing Arm Bush	1.8 16V, 1.8 16V Dualfuel, 2.0 16V Turbo, 2.0 DTI 16V, 2.2 16V, 2.2 DTI 16V		F8-4090
Belt Pulley, crankshaft	2.0 DTI 16V, 2.2 DTI 16V		F8-5639
Control Arm-/Trailing Arm Bush	1.6, 1.6 16V, 1.8, 1.8 16V, 1.8 16V Dualfuel, 1.9 CDTI, 1.9 CDTI 16V, 2.0 16V Turbo, 2.0 DTI 16V, 2.2 16V, 2.2 direct, 2.2 DTI 16V, 2.8 V6 Turbo, 3.0 CDTi, 3.0 V6 CDTI, 3.2 V6		F8-6447
Stabiliser Mounting	1.8 16V	ch.X1000001, X7000001→	F8-6660
Anti-Friction Bearing	1.6, 1.6 16V, 1.8, 1.8 16V, 1.8 16V Dualfuel, 1.9 CDTI, 1.9 CDTI 16V, 2.0 16V Turbo, 2.0 DTI 16V, 2.2 16V, 2.2 direct, 2.2 DTI 16V, 2.8 V6 Turbo, 3.0 CDTi, 3.0 V6 CDTI, 3.2 V6		F8-7172
Top Strut Mounting	1.6, 1.6 16V, 1.8, 1.8 16V, 1.8 16V Dualfuel, 1.9 CDTI, 1.9 CDTI 16V, 2.0 16V Turbo, 2.0 DTI 16V, 2.2 16V, 2.2 direct, 2.2 DTI 16V, 2.8 V6 Turbo, 3.0 CDTi, 3.0 V6 CDTI, 3.2 V6		F8-7329
Top Strut Mounting	1.6, 1.6 16V, 1.8, 1.8 16V, 1.8 16V Dualfuel, 1.9 CDTI, 1.9 CDTI 16V, 2.0 16V Turbo, 2.0 DTI 16V, 2.2 16V, 2.2 direct, 2.2 DTI 16V, 2.8 V6 Turbo, 3.0 CDTi, 3.0 V6 CDTI, 3.2 V6		F8-7330
Control Arm-/Trailing Arm Bush	1.6, 1.6 16V, 1.8, 1.8 16V, 1.8 16V Dualfuel, 1.9 CDTI, 1.9 CDTI 16V, 2.0 16V Turbo, 2.0 DTI 16V, 2.2 16V, 2.2 direct, 2.2 DTI 16V, 2.8 V6 Turbo, 3.0 CDTi, 3.0 V6 CDTI, 3.2 V6		F8-7373
Protective Cap/Bellow, shock absorber	All Models		F8-7663
Rubber Buffer, suspension	1.8, 1.8 16V, 1.8 16V Dualfuel, 1.9 CDTI, 1.9 CDTI 16V, 2.0 16V Turbo, 2.0 DTI 16V, 2.2 16V, 2.2 direct, 2.2 DTI 16V, 2.8 V6 Turbo, 3.0 CDTi, 3.0 V6 CDTI, 3.2 V6	ch.21000000, 28000000→	F8-7699
Stabiliser Mounting	1.8, 1.8 16V, 1.8 16V Dualfuel, 1.9 CDTI, 1.9 CDTI 16V, 2.0 16V Turbo, 2.0 DTI 16V, 2.2 16V, 2.2 direct, 2.2 DTI 16V, 3.0 CDTi, 3.0 V6 CDTI, 3.2 V6		F8-7919
Mounting, automatic transmission	1.9 CDTI, 1.9 CDTI 16V, 2.0 DTI 16V, 2.2 DTI 16V		F8-8170

<b>AK-735251</b>	<b>F5-1050</b>	<b>F5-1079</b>	<b>F5-1102</b>	<b>F5-1123</b>	<b>F8-4090</b>	<b>F8-5639</b>
Ref.Nr.: 344435	Ref.Nr.: 1204412	Ref.Nr.: 1204376	Ref.Nr.: 1204151	Ref.Nr.: 9948513	Ref.Nr.: 4566899	Ref.Nr.: 0614411
<b>F8-6447</b>	<b>F8-6660</b>	<b>F8-7172</b>	<b>F8-7329</b>	<b>F8-7330</b>	<b>F8-7373</b>	<b>F8-7663</b>
Ref.Nr.: 12786412	Ref.Nr.: 90496706	Ref.Nr.: 9191181	Ref.Nr.: 344529	Ref.Nr.: 344537	Ref.Nr.: 24469643	Ref.Nr.: 344435
<b>F8-7699</b>	<b>F8-7919</b>	<b>F8-8170</b>				
Ref.Nr.: 13117280	Ref.Nr.: 444160	Ref.Nr.: 9156933				

<b>Article Description</b>			<b>Article Nr.</b>	<b>Fitting Position</b>	
----------------------------	--	--	--------------------	-------------------------	--

**VECTRA Mk II (C) Estate** 10/2003 → 07/2008

Dust Cover Kit, shock absorber	1.6 16V, 1.8, 1.8 16V, 1.9 CDTi, 1.9 CDTi 16V, 2.0 16V Turbo, 2.0 DTI 16V, 2.2 direct, 2.2 DTI 16V, 2.8 V6 Turbo, 3.0 CDTi, 3.0 V6 CDTi, 3.2 V6	ST	AK-735251		
Alternator Freewheel Clutch	1.8 16V		F5-1050		
Alternator Freewheel Clutch	2.0 16V Turbo, 2.2 direct		F5-1079		
Alternator Freewheel Clutch	1.9 CDTi, 1.9 CDTi 16V		F5-1102		
Alternator Freewheel Clutch	1.9 CDTi, 1.9 CDTi 16V		F5-1123		
Belt Pulley, crankshaft	2.0 DTI 16V, 2.2 DTI 16V		F8-5639		
Control Arm-/Trailing Arm Bush	1.6 16V, 1.8, 1.8 16V, 1.9 CDTi, 1.9 CDTi 16V, 2.0 16V Turbo, 2.0 DTI 16V, 2.2 direct, 2.2 DTI 16V, 2.8 V6 Turbo, 3.0 CDTi, 3.0 V6 CDTi, 3.2 V6		F8-6447		
Stabiliser Mounting	1.8 16V	ch.X1000001, X7000001→	F8-6660		d=16
Anti-Friction Bearing	1.6 16V, 1.8, 1.8 16V, 1.9 CDTi, 1.9 CDTi 16V, 2.0 16V Turbo, 2.0 DTI 16V, 2.2 direct, 2.2 DTI 16V, 2.8 V6 Turbo, 3.0 CDTi, 3.0 V6 CDTi, 3.2 V6		F8-7172		
Top Strut Mounting	1.6 16V, 1.8, 1.8 16V, 1.9 CDTi, 1.9 CDTi 16V, 2.0 16V Turbo, 2.0 DTI 16V, 2.2 direct, 2.2 DTI 16V, 2.8 V6 Turbo, 3.0 CDTi, 3.0 V6 CDTi, 3.2 V6		F8-7329		
Top Strut Mounting	1.6 16V, 1.8, 1.8 16V, 1.9 CDTi, 1.9 CDTi 16V, 2.0 16V Turbo, 2.0 DTI 16V, 2.2 direct, 2.2 DTI 16V, 2.8 V6 Turbo, 3.0 CDTi, 3.0 V6 CDTi, 3.2 V6		F8-7330		
Control Arm-/Trailing Arm Bush	1.6 16V, 1.8, 1.8 16V, 1.9 CDTi, 1.9 CDTi 16V, 2.0 16V Turbo, 2.0 DTI 16V, 2.2 direct, 2.2 DTI 16V, 2.8 V6 Turbo, 3.0 CDTi, 3.0 V6 CDTi, 3.2 V6		F8-7373		d=12; L=52; L1=32; D=45.5
Protective Cap/Bellow, shock absorber	1.6 16V, 1.8, 1.8 16V, 1.9 CDTi, 1.9 CDTi 16V, 2.0 16V Turbo, 2.0 DTI 16V, 2.2 direct, 2.2 DTI 16V, 2.8 V6 Turbo, 3.0 CDTi, 3.0 V6 CDTi, 3.2 V6		F8-7663		H=205
Rubber Buffer, suspension	1.8, 1.8 16V, 1.9 CDTi, 1.9 CDTi 16V, 2.0 16V Turbo, 2.0 DTI 16V, 2.2 direct, 2.2 DTI 16V, 2.8 V6 Turbo, 3.0 CDTi, 3.0 V6 CDTi, 3.2 V6	ch.21000000, 28000000→	F8-7699		H=50
Stabiliser Mounting	1.8, 1.8 16V, 1.9 CDTi, 1.9 CDTi 16V, 2.0 16V Turbo, 2.0 DTI 16V, 2.2 direct, 2.2 DTI 16V, 2.8 V6 Turbo, 3.0 CDTi, 3.0 V6 CDTi, 3.2 V6		F8-7919		d=17
Mounting, automatic transmission	1.9 CDTi, 1.9 CDTi 16V, 2.0 DTI 16V, 2.2 DTI 16V		F8-8170		

**VECTRA Mk II (C) GTS** 08/2002 → 07/2008

Dust Cover Kit, shock absorber	1.6, 1.6 16V, 1.8, 1.8 16V, 1.8 16V Dualfuel, 1.9 CDTi, 1.9 CDTi 16V, 2.0 16V Turbo, 2.0 DTI 16V, 2.2 16V, 2.2 direct, 2.2 DTI 16V, 2.8 V6 Turbo, 3.0 CDTi, 3.0 V6 CDTi, 3.2 V6		AK-735253		
Alternator Freewheel Clutch	1.8 16V, 1.8 16V Dualfuel		F5-1050		
Alternator Freewheel Clutch	2.0 16V Turbo, 2.2 16V, 2.2 direct		F5-1079		
Alternator Freewheel Clutch	1.9 CDTi, 1.9 CDTi 16V		F5-1102		

<b>AK-735251</b>	<b>AK-735253</b>	<b>F5-1050</b>	<b>F5-1079</b>	<b>F5-1102</b>	<b>F5-1123</b>	<b>F8-5639</b>
Ref.Nr.: 344435	Ref.Nr.: 344426	Ref.Nr.: 1204412	Ref.Nr.: 1204376	Ref.Nr.: 1204151	Ref.Nr.: 9948513	Ref.Nr.: 0614411
<b>F8-6447</b>	<b>F8-6660</b>	<b>F8-7172</b>	<b>F8-7329</b>	<b>F8-7330</b>	<b>F8-7373</b>	<b>F8-7663</b>
Ref.Nr.: 12786412	Ref.Nr.: 90496706	Ref.Nr.: 9191181	Ref.Nr.: 344529	Ref.Nr.: 344537	Ref.Nr.: 24469643	Ref.Nr.: 344435
<b>F8-7699</b>	<b>F8-7919</b>	<b>F8-8170</b>				
Ref.Nr.: 13117280	Ref.Nr.: 444160	Ref.Nr.: 9156933				

**Article Description****Article Nr.****Fitting Position**

<b>VECTRA Mk II (C) GTS</b>		<b>08/2002 → 07/2008</b>	
Alternator Freewheel Clutch	1.9 CDTI, 1.9 CDTI 16V	<b>F5-1123</b>	
Control Arm-/Trailing Arm Bush	1.8 16V, 1.8 16V Dualfuel, 2.0 16V Turbo, 2.2 16V, 2.2 DTI 16V, 3.2 V6	<b>F8-4090</b>	⊕ ⊕ H1=50; H2=59; d=12; D1=36; D2=43
Belt Pulley, crankshaft	2.0 DTI 16V, 2.2 DTI 16V	<b>F8-5639</b>	
Control Arm-/Trailing Arm Bush	1.6, 1.6 16V, 1.8, 1.8 16V, 1.8 16V Dualfuel, 1.9 CDTI, 1.9 CDTI 16V, 2.0 16V Turbo, 2.0 DTI 16V, 2.2 16V, 2.2 direct, 2.2 DTI 16V, 2.8 V6 Turbo, 3.0 CDTi, 3.0 V6 CDTi, 3.2 V6	<b>F8-6447</b>	⊕ ⊕ ⊕ ↓
Anti-Friction Bearing	1.6, 1.6 16V, 1.8, 1.8 16V, 1.8 16V Dualfuel, 1.9 CDTI, 1.9 CDTI 16V, 2.0 16V Turbo, 2.0 DTI 16V, 2.2 16V, 2.2 direct, 2.2 DTI 16V, 2.8 V6 Turbo, 3.0 CDTi, 3.0 V6 CDTi, 3.2 V6	<b>F8-7172</b>	⊕ ⊕
Top Strut Mounting	1.6, 1.6 16V, 1.8, 1.8 16V, 1.8 16V Dualfuel, 1.9 CDTI, 1.9 CDTI 16V, 2.0 16V Turbo, 2.0 DTI 16V, 2.2 16V, 2.2 direct, 2.2 DTI 16V, 2.8 V6 Turbo, 3.0 CDTi, 3.0 V6 CDTi, 3.2 V6	<b>F8-7329</b>	⊕ ⊕
Top Strut Mounting	1.6, 1.6 16V, 1.8, 1.8 16V, 1.8 16V Dualfuel, 1.9 CDTI, 1.9 CDTI 16V, 2.0 16V Turbo, 2.0 DTI 16V, 2.2 16V, 2.2 direct, 2.2 DTI 16V, 2.8 V6 Turbo, 3.0 CDTi, 3.0 V6 CDTi, 3.2 V6	<b>F8-7330</b>	⊕ ⊕
Control Arm-/Trailing Arm Bush	1.6, 1.6 16V, 1.8, 1.8 16V, 1.8 16V Dualfuel, 1.9 CDTI, 1.9 CDTI 16V, 2.0 16V Turbo, 2.0 DTI 16V, 2.2 16V, 2.2 direct, 2.2 DTI 16V, 2.8 V6 Turbo, 3.0 CDTi, 3.0 V6 CDTi, 3.2 V6	<b>F8-7373</b>	⊕ ⊕ d=12; L=52; L1=32; D=45.5
Protective Cap/Bellow, shock absorber	All Models	<b>F8-7663</b>	⊕ ⊕ H=205
Rubber Buffer, suspension	1.8, 1.8 16V Dualfuel, 1.9 CDTI, 1.9 CDTI 16V, 2.0 16V Turbo, 2.0 DTI 16V, 2.2 16V, 2.2 DTI 16V, 2.8 V6 Turbo, 3.0 CDTi, 3.0 V6 CDTi, 3.2 V6	ch.21000000, 28000000→ <b>F8-7699</b>	⊕ ⊕ H=50
Stabiliser Mounting	1.8, 1.8 16V, 1.8 16V Dualfuel, 1.9 CDTI, 1.9 CDTI 16V, 2.0 16V Turbo, 2.0 DTI 16V, 2.2 16V, 2.2 direct, 2.2 DTI 16V, 2.8 V6 Turbo, 3.0 CDTi, 3.0 V6 CDTi, 3.2 V6	<b>F8-7919</b>	⊕ ⊕ d=17
Mounting, automatic transmission	1.9 CDTI, 1.9 CDTI 16V, 2.0 DTI 16V, 2.2 DTI 16V	<b>F8-8170</b>	
<b>VICEROY</b>		<b>01/1980 → 10/1982</b>	
Dust Cover Kit, shock absorber	All Models	<b>AK-735005</b>	⊕ ⊕
<b>VIVARO Combi (J7)</b>		<b>08/2001 → 07/2014</b>	
Alternator Freewheel Clutch	2.0 CDTI	<b>F5-1110</b>	
Top Strut Mounting	1.9 DI, 1.9 DTI, 2.0 16V, 2.0 CDTI, 2.5 DTI	<b>F8-6196</b>	⊕ ⊕
Top Strut Mounting	1.9 DI, 1.9 DTI, 2.0 16V, 2.0 CDTI, 2.5 DTI	<b>F8-6197</b>	⊕ ⊕
Bellow Set, steering	1.9 DI, 1.9 DTI, 2.0 16V, 2.0 CDTI, 2.5 DTI	with clamps <b>F8-6478</b>	⊕ ⊕ d1=13; d2=54,5; L [mm]=215
Mounting, axle beam	1.9 DI, 1.9 DTI, 2.0 16V, 2.0 CDTI, 2.5 DTI	<b>F8-6661</b>	⊕ ⊕

<b>AK-735005</b>	<b>F5-1110</b>	<b>F5-1123</b>	<b>F8-4090</b>	<b>F8-5639</b>	<b>F8-6196</b>	<b>F8-6197</b>
Ref.Nr.:	Ref.Nr.: 8200489514	Ref.Nr.: 9948513	Ref.Nr.: 4566899	Ref.Nr.: 0614411	Ref.Nr.: 54320-00QAA	Ref.Nr.: 7701207491SK
<b>F8-6447</b>	<b>F8-6478</b>	<b>F8-6661</b>	<b>F8-6690</b>	<b>F8-7172</b>	<b>F8-7329</b>	<b>F8-7330</b>
Ref.Nr.: 12786412	Ref.Nr.: 48203-00QAE	Ref.Nr.: 4412907	Ref.Nr.: 11323-00QAA	Ref.Nr.: 9191181	Ref.Nr.: 344529	Ref.Nr.: 344537
<b>F8-7373</b>	<b>F8-7663</b>	<b>F8-7699</b>	<b>F8-7919</b>	<b>F8-8170</b>		
Ref.Nr.: 24469643	Ref.Nr.: 344435	Ref.Nr.: 13117280	Ref.Nr.: 444160	Ref.Nr.: 9156933		

Article Description



Article Nr.

Fitting Position



<b>VIVARO Combi (J7)</b>			08/2001 → 07/2014		
Engine Mounting	1.9 DI, 1.9 DTI, 2.0 16V, 2.0 ECOTEC		<b>F8-6690</b>	↺	
Engine Mounting	1.9 DI, 1.9 DTI, 2.0 16V, 2.0 ECOTEC		<b>F8-6691</b>	↺	
Engine Mounting	2.0 CDTI	M9R 780, M9R 786, M9R 788; not for  M9R630, M9R692	<b>F8-6691</b>	↺	
Engine Mounting	2.0 CDTI	M9R 780; not for  M9R630, M9R692	<b>F8-6691</b>	↺	
Engine Mounting	1.9 DI, 1.9 DTI, 2.0 16V, 2.0 ECOTEC		<b>F8-6692</b>	↑	
Engine Mounting	1.9 DI, 1.9 DTI, 2.0 16V, 2.0 ECOTEC		<b>F8-6693</b>	↓	
Anti-Friction Bearing	1.9 DI, 1.9 DTI, 2.0 16V, 2.0 CDTI, 2.5 DTI		<b>F8-7151</b>		H1=15; H2=12; d=16; D=52
Engine Mounting	2.0 CDTI, 2.5 CDTI, 2.5 DTI		<b>F8-7733</b>	↺	
Engine Mounting	2.0 CDTI, 2.5 CDTI, 2.5 DTI		<b>F8-7736</b>	↓	
Engine Mounting	2.0 CDTI		<b>F8-7737</b>	↺↑	
<b>VIVARO Box (F7)</b>			08/2001 → 07/2014		
Alternator Freewheel Clutch	2.0 CDTI		<b>F5-1110</b>		
Top Strut Mounting	1.9 DI, 1.9 DTI, 2.0 16V, 2.0 CDTI, 2.5 CDTI, 2.5 DTI		<b>F8-6196</b>		
Top Strut Mounting	1.9 DI, 1.9 DTI, 2.0 16V, 2.0 CDTI, 2.5 CDTI, 2.5 DTI		<b>F8-6197</b>		
Bellow Set, steering	1.9 DI, 1.9 DTI, 2.0 16V, 2.0 CDTI, 2.5 CDTI, 2.5 DTI	with clamps	<b>F8-6478</b>		d1=13; d2=54,5; L [mm]=215
Mounting, axle beam	1.9 DI, 1.9 DTI, 2.0 16V, 2.0 CDTI, 2.5 CDTI, 2.5 DTI		<b>F8-6661</b>		
Engine Mounting	1.9 DI, 1.9 DTI, 2.0 16V, 2.0 ECOTEC		<b>F8-6690</b>	↺	
Engine Mounting	1.9 DI, 1.9 DTI, 2.0 16V, 2.0 ECOTEC		<b>F8-6691</b>	↺	
Engine Mounting	2.0 CDTI	M9R 780, M9R 788; not for  M9R630, M9R692	<b>F8-6691</b>	↺	
Engine Mounting	2.0 CDTI	M9R 780; not for  M9R630, M9R692	<b>F8-6691</b>	↺	
Engine Mounting	1.9 DI, 1.9 DTI, 2.0 16V, 2.0 ECOTEC		<b>F8-6692</b>	↑	
Engine Mounting	1.9 DI, 1.9 DTI, 2.0 16V, 2.0 ECOTEC		<b>F8-6693</b>	↓	
Anti-Friction Bearing	1.9 DI, 1.9 DTI, 2.0 16V, 2.0 CDTI, 2.5 CDTI, 2.5 DTI		<b>F8-7151</b>		H1=15; H2=12; d=16; D=52
Engine Mounting	2.0 CDTI, 2.5 CDTI, 2.5 DTI		<b>F8-7733</b>	↺	
Engine Mounting	2.0 CDTI, 2.5 CDTI, 2.5 DTI		<b>F8-7736</b>	↓	
Engine Mounting	2.0 CDTI		<b>F8-7737</b>	↺↑	
<b>VIVARO Platform/Chassis (E7)</b>			04/2003 → 07/2014		
Alternator Freewheel Clutch	2.0 CDTI		<b>F5-1110</b>		
Top Strut Mounting	2.0 CDTI, 2.5 CDTI		<b>F8-6196</b>		
Top Strut Mounting	2.0 CDTI, 2.5 CDTI		<b>F8-6197</b>		
Bellow Set, steering	2.0 CDTI, 2.5 CDTI	with clamps	<b>F8-6478</b>		d1=13; d2=54,5; L [mm]=215
Mounting, axle beam	2.0 CDTI, 2.5 CDTI		<b>F8-6661</b>		

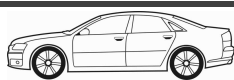

**Article Description****Article Nr.****Fitting Position**

<b>VIVARO Platform/Chassis (E7)</b>				<b>04/2003 → 07/2014</b>	
Engine Mounting	1.9 DI, 2.0 16V, 2.0 ECOTEC		<b>F8-6690</b>	⊕	
Engine Mounting	1.9 DI, 2.0 16V, 2.0 ECOTEC		<b>F8-6691</b>	⊕	
Engine Mounting	2.0 CDTI	not for  M9R630, M9R692	<b>F8-6691</b>	⊕	
Engine Mounting	2.0 CDTI	M9R 780, M9R 788; not for  M9R630, M9R692	<b>F8-6691</b>	⊕	
Engine Mounting	1.9 DI, 2.0 16V, 2.0 ECOTEC		<b>F8-6692</b>	↑	
Engine Mounting	1.9 DI, 2.0 16V, 2.0 ECOTEC		<b>F8-6693</b>	↓	
Anti-Friction Bearing	2.0 CDTI, 2.5 CDTI		<b>F8-7151</b>		H1=15; H2=12; d=16; D=52
Engine Mounting	2.0 CDTI, 2.5 CDTI		<b>F8-7733</b>	⊕	
Engine Mounting	2.0 CDTI, 2.5 CDTI		<b>F8-7736</b>	↓	
Engine Mounting	2.0 CDTI		<b>F8-7737</b>	⊕↑	
<b>ZAFIRA Mk I (A) (F75)</b>				<b>11/1998 → 08/2005</b>	
Rubber Buffer, suspension	1.6 16V, 1.8 16V, 2.0 DI 16V, 2.0 DTI 16V, 2.0 GSI Turbo, 2.2 16V		<b>AK-735038</b>		
Alternator Freewheel Clutch	1.6 16V, 1.8 16V		<b>F5-1050</b>		
Control Arm-/Trailing Arm Bush	1.6 16V, 1.8 16V, 2.0 DI 16V, 2.0 DTI 16V, 2.2 16V		<b>F8-4090</b>		H1=50; H2=59; d=12; D1=36; D2=43
Control Arm-/Trailing Arm Bush	1.6 16V, 1.8 16V, 2.0 DI 16V, 2.0 DTI 16V, 2.2 16V		<b>F8-5130</b>		H=60; d=12; D=47
Engine Mounting	1.6 16V, 1.8 16V	Code: KZ YU;	<b>F8-5365</b>	⊕	
Top Strut Mounting	1.6 16V, 1.8 16V, 2.0 DI 16V, 2.0 DTI 16V, 2.0 GSI Turbo, 2.2 16V	Bearing Type: Soft Version;	<b>F8-5448</b>		
Top Strut Mounting	1.6 16V, 1.8 16V, 2.0 DI 16V, 2.0 DTI 16V, 2.0 GSI Turbo, 2.2 16V	;	<b>F8-5463</b>		
Belt Pulley, crankshaft	2.0 DI 16V, 2.2 D		<b>F8-5639</b>		
Belt Pulley, crankshaft	2.0 DTI 16V	09/2000 →	<b>F8-5639</b>		
Rubber Buffer, suspension	1.6 16V, 1.8 16V, 2.0 DTI 16V, 2.0 GSI Turbo, 2.2 16V		<b>F8-5878</b>		H=62.5; d=24; D=50
Rubber Buffer, suspension	1.6 16V, 1.8 16V, 2.0 DTI 16V, 2.0 GSI Turbo, 2.2 16V		<b>F8-5913</b>		H=53; d=19; D=50
Engine Mounting	2.0 DI 16V, 2.0 DTI 16V		<b>F8-6494</b>		
Rubber Buffer, suspension	1.6 16V, 1.8 16V, 2.0, 2.0 DI 16V, 2.0 DTI 16V, 2.0 GSI Turbo, 2.2 16V, 2.2 D		<b>F8-6517</b>		
Mounting, axle beam	1.6 16V, 1.8 16V, 2.0, 2.0 DI 16V, 2.0 DTI 16V, 2.0 GSI Turbo, 2.2 16V		<b>F8-6733</b>		d=14; L=35; D1=46; D2=38.4
Mounting, axle beam	1.6 16V, 1.8 16V, 2.0, 2.0 DI 16V, 2.0 DTI 16V, 2.0 GSI Turbo, 2.2 16V		<b>F8-6734</b>		H=35.2; d=14.2; D1=45.9; D2=35.2
Engine Mounting	1.6 16V, 1.8 16V	Yellow;	<b>F8-6755</b>		
Engine Mounting	1.6 16V, 1.8 16V		<b>F8-6835</b>		
Engine Mounting	2.0 DTI 16V	ch.32000001, 35000001, 36000001, 38000001, 3B000001, 3H000001, 4G000001→	<b>F8-6836</b>	⊕	

<b>AK-735038</b>	<b>F5-1050</b>	<b>F8-4090</b>	<b>F8-5130</b>	<b>F8-5365</b>	<b>F8-5448</b>	<b>F8-5463</b>
Ref.Nr.: 344417	Ref.Nr.: 1204412	Ref.Nr.: 4566899	Ref.Nr.: 352365	Ref.Nr.: 5684045	Ref.Nr.: 0344523	Ref.Nr.: 0344525
<b>F8-5639</b>	<b>F8-5878</b>	<b>F8-5913</b>	<b>F8-6494</b>	<b>F8-6517</b>	<b>F8-6690</b>	<b>F8-6691</b>
Ref.Nr.: 0614411	Ref.Nr.: 0344417	Ref.Nr.: 0344421	Ref.Nr.: 0 684 697	Ref.Nr.: 90468618	Ref.Nr.: 11323-00QAA	Ref.Nr.: 11246-00QAB
<b>F8-6692</b>	<b>F8-6693</b>	<b>F8-6733</b>	<b>F8-6734</b>	<b>F8-6755</b>	<b>F8-6835</b>	<b>F8-6836</b>
Ref.Nr.: 11356-00QAA	Ref.Nr.: 11238-00QAA	Ref.Nr.: 13107328	Ref.Nr.: 302275	Ref.Nr.: 90575457	Ref.Nr.: 684694	Ref.Nr.: 24427298

Article Description



Article Nr.

Fitting Position



### ZAFIRA Mk I (A) (F75)

11/1998 → 08/2005

Engine Mounting	2.0 GSI Turbo	Manufacturer Restriction: Code:HP;	<b>F8-6944</b>		
Engine Mounting	2.2 16V		<b>F8-6974</b>		
Rubber Buffer, suspension	1.6 CNG		<b>F8-7662</b>	⊕ ⊕	H=40
Protective Cap/Bellow, shock absorber	1.6 CNG		<b>F8-7663</b>	⊕ ⊕	H=205
Engine Mounting	1.6 16V, 1.8 16V		<b>F8-8071</b>		
Engine Mounting	1.6 16V, 1.8 16V, 2.0 DI 16V, 2.0 GSI Turbo, 2.2 16V		<b>F8-8137</b>		
Engine Mounting	2.0 DI 16V		<b>F8-8155</b>	⊕	

### ZAFIRA Mk II (B) (M75)

04/2005 → 11/2014

Dust Cover Kit, shock absorber	1.6, 1.7 CDTI, 1.8, 1.9 CDTI, 2.0, 2.2		<b>AK-735251</b>	⊕ ⊕ ⊕	
Dust Cover Kit, shock absorber	1.6, 1.8, 1.9 CDTI, 2.0, 2.2	<b>ST</b>	<b>AK-735252</b>	⊕ ⊕ ⊕	
Alternator Freewheel Clutch	1.7 CDTI		<b>F5-1049</b>		
Alternator Freewheel Clutch	2.2		<b>F5-1079</b>		
Alternator Freewheel Clutch	2.0		<b>F5-1100</b>		
Alternator Freewheel Clutch	1.9 CDTI		<b>F5-1102</b>		
Alternator Freewheel Clutch	1.9 CDTI		<b>F5-1123</b>		
Mounting, axle beam	1.6, 1.8, 1.9 CDTI, 2.0, 2.2		<b>F8-6733</b>	⊕ ⊕ ⊕	d=14; L=35; D1=46; D2=38.4
Mounting, axle beam	1.6, 1.8, 1.9 CDTI, 2.0, 2.2		<b>F8-6734</b>	⊕ ⊕ ⊕	H=35.2; d=14.2; D1=45.9; D2=35.2
Engine Mounting	1.9 CDTI		<b>F8-6836</b>	⊕	
Engine Mounting	1.6	Code: KZ JE	<b>F8-6975</b>		
Engine Mounting	1.8	Code: KZ JE;  Z 18 XER	<b>F8-6975</b>		
Engine Mounting	1.6	Code: KZ KD;  Z 16 XEP	<b>F8-6980</b>	⊕	
Engine Mounting	1.8	Code: KZ KD;  Z 18 XER	<b>F8-6980</b>	⊕	
Engine Mounting	1.9 CDTI	Code: KZ KA;	<b>F8-6984</b>	⊕	
Engine Mounting	2.2	Code: KZ KA;	<b>F8-6984</b>	⊕	
Anti-Friction Bearing	1.6, 1.7 CDTI, 1.8, 1.9 CDTI, 2.0, 2.2		<b>F8-7172</b>	⊕ ⊕ ⊕	
Top Strut Mounting	1.6, 1.7 CDTI, 1.8, 1.9 CDTI, 2.0, 2.2	Additionally required articles: F8-7625;	<b>F8-7327</b>	⊕ ⊕ ⊕	
Top Strut Mounting	1.6, 1.7 CDTI, 1.8, 1.9 CDTI, 2.0, 2.2		<b>F8-7328</b>	⊕ ⊕ ⊕	
Top Strut Mounting	1.6, 1.7 CDTI, 1.8, 1.9 CDTI, 2.0, 2.2		<b>F8-7328S</b>	⊕ ⊕ ⊕	
Mounting Kit, shock absorber	1.6, 1.6 CNG, 1.6 CNG Turbo, 1.7 CDTI, 1.8, 1.9 CDTI, 2.0, 2.2	for article nr: A-3246GL & A-3246GR, F8-7327	<b>F8-7625</b>	⊕ ⊕ ⊕	
Rubber Buffer, suspension	1.6 CNG Turbo	Z 16 XNT;	<b>F8-7662</b>	⊕ ⊕ ⊕	H=40
Rubber Buffer, suspension	1.6, 1.6 CNG, 1.7 CDTI, 1.8, 1.9 CDTI, 2.0, 2.2		<b>F8-7662</b>	⊕ ⊕ ⊕	H=40

<b>AK-735251</b>	<b>AK-735252</b>	<b>F5-1049</b>	<b>F5-1079</b>	<b>F5-1100</b>	<b>F5-1102</b>	<b>F5-1123</b>
Ref.Nr.: 344435	Ref.Nr.: 344416	Ref.Nr.: 1204366	Ref.Nr.: 1204376	Ref.Nr.: 1204393	Ref.Nr.: 1204151	Ref.Nr.: 9948513
<b>F8-6733</b>	<b>F8-6734</b>	<b>F8-6836</b>	<b>F8-6944</b>	<b>F8-6974</b>	<b>F8-6975</b>	<b>F8-6980</b>
Ref.Nr.: 13107328	Ref.Nr.: 302275	Ref.Nr.: 24427298	Ref.Nr.: 13115706	Ref.Nr.: 684249	Ref.Nr.: 24459803	Ref.Nr.: 13125637
<b>F8-6984</b>	<b>F8-7172</b>	<b>F8-7327</b>	<b>F8-7328</b>	<b>F8-7328S</b>	<b>F8-7625</b>	<b>F8-7662</b>
Ref.Nr.: 13159997	Ref.Nr.: 9191181	Ref.Nr.: 13186960	Ref.Nr.: 13270705	Ref.Nr.: 344625	Ref.Nr.: 24402155	Ref.Nr.: 0344956



Article Description

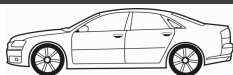

Article Nr.

Fitting Position



<b>ZAFIRA Mk II (B) (M75)</b>			<b>04/2005 → 11/2014</b>		
Protective Cap/Bellow, shock absorber	1.6, 1.6 CNG, 1.6 CNG Turbo, 1.7 CDTI, 1.8, 1.9 CDTI, 2.0, 2.2		<b>F8-7663</b>		H=205
Rubber Buffer, suspension	1.6, 1.6 CNG, 1.6 CNG Turbo, 1.7 CDTI, 1.8, 1.9 CDTI, 2.0, 2.2		<b>F8-7699</b>		H=50
Belt Pulley, crankshaft	1.7 CDTI	Number of Ribs: 5; Parameter: 6PK	<b>F8-7872</b>		Belt Pulley Ø [mm]=149; H1=22; H2=32
Mounting, axle beam	1.6	Z 16 XEP	<b>F8-7944</b>		d=13
Mounting, axle beam	1.6	Z 16 XER	<b>F8-7944</b>		d=13
Mounting, axle beam	1.6 CNG, 1.7 CDTI, 1.9 CDTI, 2.0, 2.2		<b>F8-7944</b>		d=13
Mounting, axle beam	1.8	Z 18 XER	<b>F8-7944</b>		d=13
Engine Mounting	1.6, 1.6 CNG, 1.6 CNG Turbo, 1.7 CDTI, 1.8, 1.9 CDTI, 2.0, 2.2		<b>F8-8137</b>		
Engine Mounting	1.6		<b>F8-8142</b>		

<b>F8-7663</b>	<b>F8-7699</b>	<b>F8-7872</b>	<b>F8-7944</b>	<b>F8-8137</b>	<b>F8-8142</b>
Ref.Nr.: 344435	Ref.Nr.: 13117280	Ref.Nr.: 614758	Ref.Nr.: 402 952	Ref.Nr.: 682502	Ref.Nr.: 90538582

<b>Article Description</b>			<b>Article Nr.</b>	<b>Fitting Position</b>	
----------------------------	--	--	--------------------	-------------------------	--

<b>140 (142, 144)</b>			<b>08/1966 → 08/1975</b>		
Control Arm-/Trailing Arm Bush	All Models		<b>F8-5129</b>	⊕ ⊕ ↓	d=12; L=65; D=34.5, 43.5
<b>240 (P242, P244)</b>			<b>08/1974 → 12/1993</b>		
Dust Cover Kit, shock absorber	2.0, 2.1, 2.3, 2.3 i CAT, 2.4 Diesel		<b>AK-735110</b>	⊕ ⊕ ⊕	
Control Arm-/Trailing Arm Bush	2.0, 2.1, 2.1 Turbo, 2.3, 2.3 i CAT, 2.4 Diesel, 2.7 GLT6		<b>F8-5076</b>	⊕ ⊕ ⊕ ↓	d=18; L=45; D=54.5, 68.5
Control Arm-/Trailing Arm Bush	2.0, 2.1, 2.1 Turbo, 2.3, 2.3 i CAT, 2.4 Diesel, 2.7 GLT6		<b>F8-5129</b>	⊕ ⊕ ⊕ ↓	d=12; L=65; D=34.5, 43.5
Mounting, stabilizer coupling rod	2.0, 2.1, 2.1 Turbo, 2.3, 2.3 i CAT, 2.4 Diesel		<b>F8-5571</b>	⊕ ⊕ ⊕	H=22.5; d=10; D=32.5
Control Arm-/Trailing Arm Bush	2.0, 2.1, 2.1 Turbo, 2.3, 2.4 Diesel		<b>F8-5691</b>		H1=50; H2=37; d=13; D=48
Control Arm-/Trailing Arm Bush	2.0, 2.1, 2.1 Turbo, 2.3, 2.3 i CAT, 2.4 Diesel, 2.7 GLT6		<b>F8-5718</b>	⊕ ⊕ ⊕ ↓	H=86; d=19; D=57
Suspension, panhard rod	2.0, 2.1, 2.1 Turbo, 2.3, 2.3 i CAT, 2.4 Diesel, 2.7 GLT6		<b>F8-5735</b>	⊕	H=40; d=20; D=40.5
Suspension, panhard rod	2.0, 2.1, 2.1 Turbo, 2.3, 2.3 i CAT, 2.4 Diesel, 2.7 GLT6		<b>F8-5736</b>	⊕	H=50; d=12; D=40
Control Arm-/Trailing Arm Bush	2.0, 2.1, 2.1 Turbo, 2.3, 2.3 i CAT, 2.4 Diesel, 2.7 GLT6		<b>F8-5762</b>	⊕ ⊕ ⊕	H=76; d=14; D=41
Bearing Bush, stabiliser	2.0, 2.1, 2.1 Turbo, 2.3, 2.3 i CAT, 2.4 Diesel, 2.7 GLT6		<b>F8-6769</b>	⊕ ⊕ ⊕	H=53.8; d=20.8
<b>240 Kombi (P245)</b>			<b>08/1974 → 12/1993</b>		
Dust Cover Kit, shock absorber	2.0, 2.1, 2.3, 2.3 CAT, 2.3 i CAT, 2.4 Diesel		<b>AK-735110</b>	⊕ ⊕ ⊕	
Control Arm-/Trailing Arm Bush	2.0, 2.1, 2.1 Turbo, 2.3, 2.3 i CAT, 2.4 Diesel, 2.7 GLT6		<b>F8-5076</b>	⊕ ⊕ ⊕ ↓	d=18; L=45; D=54.5, 68.5
Control Arm-/Trailing Arm Bush	2.0, 2.1, 2.1 Turbo, 2.3, 2.3 i CAT, 2.4 Diesel, 2.7 GLT6		<b>F8-5129</b>	⊕ ⊕ ⊕ ↓	d=12; L=65; D=34.5, 43.5
Mounting, stabilizer coupling rod	2.0, 2.1, 2.1 Turbo, 2.3, 2.3 i CAT, 2.4 Diesel		<b>F8-5571</b>	⊕ ⊕ ⊕	H=22.5; d=10; D=32.5
Control Arm-/Trailing Arm Bush	2.0, 2.1, 2.3, 2.3 i CAT, 2.4 Diesel		<b>F8-5691</b>		H1=50; H2=37; d=13; D=48
Control Arm-/Trailing Arm Bush	2.0, 2.1, 2.1 Turbo, 2.3, 2.3 CAT, 2.3 i CAT, 2.4 Diesel, 2.7 GLT6		<b>F8-5718</b>	⊕ ⊕ ⊕ ↓	H=86; d=19; D=57
Suspension, panhard rod	2.0, 2.1, 2.1 Turbo, 2.3, 2.3 i CAT, 2.4 Diesel, 2.7 GLT6		<b>F8-5735</b>	⊕	H=40; d=20; D=40.5
Suspension, panhard rod	2.0, 2.1, 2.1 Turbo, 2.3, 2.3 i CAT, 2.4 Diesel, 2.7 GLT6		<b>F8-5736</b>	⊕	H=50; d=12; D=40
Control Arm-/Trailing Arm Bush	2.0, 2.1, 2.1 Turbo, 2.3, 2.3 CAT, 2.3 i CAT, 2.4 Diesel, 2.7 GLT6		<b>F8-5762</b>	⊕ ⊕ ⊕	H=76; d=14; D=41
Bearing Bush, stabiliser	2.0, 2.1, 2.1 Turbo, 2.3, 2.3 CAT, 2.3 i CAT, 2.4 Diesel, 2.7 GLT6		<b>F8-6769</b>	⊕ ⊕ ⊕	H=53.8; d=20.8

<b>AK-735110</b>	<b>F8-5076</b>	<b>F8-5129</b>	<b>F8-5571</b>	<b>F8-5691</b>	<b>F8-5718</b>	<b>F8-5735</b>
Ref.Nr.:	Ref.Nr.: 12737789	Ref.Nr.: 1205825	Ref.Nr.: 1205991	Ref.Nr.: 1273622	Ref.Nr.: 1229165	Ref.Nr.: 1330427
<b>F8-5736</b>	<b>F8-5762</b>	<b>F8-6769</b>				
Ref.Nr.: 1229715	Ref.Nr.: 1229714	Ref.Nr.: 1359808				



**Article Description****Article Nr.****Fitting Position**

<b>260 (P262, P264)</b>		<b>08/1974 → 07/1982</b>	
Dust Cover Kit, shock absorber	All Models	<b>AK-735110</b>	
Control Arm-/Trailing Arm Bush	All Models	<b>F8-5076</b>	d=18; L=45; D=54.5, 68.5
Control Arm-/Trailing Arm Bush	All Models	<b>F8-5129</b>	d=12; L=65; D=34.5, 43.5
Mounting, stabilizer coupling rod	All Models	<b>F8-5571</b>	H=22.5; d=10; D=32.5
Control Arm-/Trailing Arm Bush	All Models	<b>F8-5691</b>	H1=50; H2=37; d=13; D=48
Control Arm-/Trailing Arm Bush	All Models	<b>F8-5718</b>	H=86; d=19; D=57
Suspension, panhard rod	All Models	<b>F8-5735</b>	H=40; d=20; D=40.5
Suspension, panhard rod	All Models	<b>F8-5736</b>	H=50; d=12; D=40
Control Arm-/Trailing Arm Bush	All Models	<b>F8-5762</b>	H=76; d=14; D=41
Bearing Bush, stabiliser	All Models	<b>F8-6769</b>	H=53.8; d=20.8
<b>260 Coupe (P262)</b>		<b>08/1977 → 07/1978</b>	
Control Arm-/Trailing Arm Bush	2.7	<b>F8-5076</b>	d=18; L=45; D=54.5, 68.5
Control Arm-/Trailing Arm Bush	2.7	<b>F8-5129</b>	d=12; L=65; D=34.5, 43.5
Control Arm-/Trailing Arm Bush	2.7	<b>F8-5718</b>	H=86; d=19; D=57
Suspension, panhard rod	2.7	<b>F8-5735</b>	H=40; d=20; D=40.5
Suspension, panhard rod	2.7	<b>F8-5736</b>	H=50; d=12; D=40
Control Arm-/Trailing Arm Bush	2.7	<b>F8-5762</b>	H=76; d=14; D=41
Bearing Bush, stabiliser	2.7	<b>F8-6769</b>	H=53.8; d=20.8
<b>260 Estate (P265)</b>		<b>07/1975 → 07/1982</b>	
Dust Cover Kit, shock absorber	All Models	<b>AK-735110</b>	
Control Arm-/Trailing Arm Bush	All Models	<b>F8-5076</b>	d=18; L=45; D=54.5, 68.5
Control Arm-/Trailing Arm Bush	All Models	<b>F8-5129</b>	d=12; L=65; D=34.5, 43.5
Mounting, stabilizer coupling rod	All Models	<b>F8-5571</b>	H=22.5; d=10; D=32.5
Control Arm-/Trailing Arm Bush	2.7	<b>F8-5691</b>	H1=50; H2=37; d=13; D=48
Control Arm-/Trailing Arm Bush	All Models	<b>F8-5718</b>	H=86; d=19; D=57
Suspension, panhard rod	All Models	<b>F8-5735</b>	H=40; d=20; D=40.5

<b>AK-735110</b>	<b>F8-5076</b>	<b>F8-5129</b>	<b>F8-5571</b>	<b>F8-5691</b>	<b>F8-5718</b>	<b>F8-5735</b>
Ref.Nr.:	Ref.Nr.: 12737789	Ref.Nr.: 1205825	Ref.Nr.: 1205991	Ref.Nr.: 1273622	Ref.Nr.: 1229165	Ref.Nr.: 1330427
<b>F8-5736</b>	<b>F8-5762</b>	<b>F8-6769</b>				
Ref.Nr.: 1229715	Ref.Nr.: 1229714	Ref.Nr.: 1359808				

**Article Description**

**Article Nr.**
**Fitting Position**

<b>260 Estate (P265)</b>		<b>07/1975 → 07/1982</b>	
Suspension, panhard rod	All Models	<b>F8-5736</b>	⊕
Control Arm-/Trailing Arm Bush	All Models	<b>F8-5762</b>	⊕ ⊕
Bearing Bush, stabiliser	All Models	<b>F8-6769</b>	⊕ ⊕ ⊕
<b>340-360 (343, 345)</b>		<b>08/1975 → 07/1991</b>	
Dust Cover Kit, shock absorber	1.4	<b>AK-735030</b>	⊕ ⊕ ⊕
Dust Cover Kit, shock absorber	1.4, 1.6 Diesel, 1.7, 2.0	<b>AK-735030</b>	⊕ ⊕ ⊕
<b>340-360 Saloon (344)</b>		<b>08/1982 → 07/1991</b>	
Dust Cover Kit, shock absorber	1.4, 1.6 Diesel, 2.0	<b>AK-735030</b>	⊕ ⊕ ⊕
<b>440 K (445)</b>		<b>08/1988 → 12/1996</b>	
Dust Cover Kit, shock absorber	1.6, 1.7, 1.7 Turbo, 1.8, 1.9 Turbo-Diesel, 2.0	<b>AK-735080</b>	
Anti-Friction Bearing	All Models	<b>F8-3033</b>	⊕ ⊕ ⊕
Mounting, automatic transmission	1.6, 1.7, 1.7 Turbo, 1.8, 1.9 Turbo-Diesel, 2.0	<b>F8-7028</b>	⊕
<b>460 L (464)</b>		<b>09/1988 → 07/1996</b>	
Dust Cover Kit, shock absorber	1.6, 1.7, 1.7 Turbo, 1.8, 1.9 Turbo-Diesel, 2.0	<b>AK-735080</b>	
Anti-Friction Bearing	All Models	<b>F8-3033</b>	⊕ ⊕ ⊕
Mounting, automatic transmission	1.6, 1.7 Turbo, 1.8, 1.9 Turbo-Diesel, 2.0	<b>F8-7028</b>	⊕
<b>480 E</b>		<b>04/1986 → 07/1996</b>	
Dust Cover Kit, shock absorber	All Models	<b>AK-735080</b>	
Anti-Friction Bearing	All Models	<b>F8-3033</b>	⊕ ⊕ ⊕
Mounting, automatic transmission	All Models	<b>F8-7028</b>	⊕
<b>740 (744)</b>		<b>04/1983 → 08/1992</b>	
Dust Cover Kit, shock absorber	2.3, 2.3 Turbo, 2.4 Diesel	<b>AK-735012</b>	⊕ ⊕ ⊕
Control Arm-/Trailing Arm Bush	2.0, 2.3, 2.3 Turbo, 2.4 TD	<b>F8-5106</b>	⊕ ⊕ ⊕
Control Arm-/Trailing Arm Bush	2.3, 2.4 Diesel	<b>F8-5106</b>	⊕ ⊕ ⊕
Control Arm-/Trailing Arm Bush	2.3, 2.3 Turbo	<b>F8-5140</b>	⊕ ⊕ ⊕
Control Arm-/Trailing Arm Bush	2.3, 2.4 Diesel	<b>F8-5140</b>	⊕ ⊕ ⊕
Mounting, stabilizer coupling rod	2.3, 2.3 Turbo, 2.4 Diesel	<b>F8-5571</b>	⊕ ⊕ ⊕
Suspension, panhard rod	2.0, 2.3, 2.3 Turbo, 2.4 Diesel, 2.4 TD	<b>F8-5735</b>	⊕
Suspension, panhard rod	2.0, 2.3, 2.3 Turbo, 2.4 Diesel, 2.4 TD	<b>F8-5736</b>	⊕



**Article Description****Article Nr.****Fitting Position**

<b>740 (744)</b>			<b>04/1983 → 08/1992</b>		
Rubber Buffer, suspension	2.0, 2.0 GLE, 2.0 Turbo, 2.3, 2.3 GLE, 2.3 Turbo, 2.4 Diesel, 2.4 TD		<b>F8-5899</b>		D=25; H=95
Top Strut Mounting	2.0, 2.0 GLE, 2.0 Turbo, 2.3, 2.3 GLE, 2.3 Turbo, 2.4 Diesel, 2.4 TD		<b>F8-5983</b>		d=18
Top Strut Mounting	2.0, 2.0 GLE, 2.0 Turbo, 2.3, 2.3 GLE, 2.3 Turbo, 2.4 Diesel, 2.4 TD		<b>F8-5984</b>		d=18
Anti-Friction Bearing	2.0, 2.3, 2.3 Turbo, 2.4 Diesel, 2.4 TD		<b>F8-6267</b>		H=12; W=91
Mounting, automatic transmission	All Models		<b>F8-6549</b>		
Bearing Bush, stabiliser	2.0, 2.3, 2.3 Turbo, 2.4 Diesel, 2.4 TD		<b>F8-6769</b>		H=53.8; d=20.8
Engine Mounting	2.3	Bearing Type: Hard Version; White	<b>F8-7354</b>		
Engine Mounting	2.3, 2.3 Turbo	Bearing Type: Soft Version	<b>F8-7355</b>		

<b>740 Kombi (745)</b>			<b>08/1984 → 08/1992</b>		
Dust Cover Kit, shock absorber	2.0, 2.3, 2.3 Turbo, 2.4 Diesel, 2.4 Turbo-Diesel		<b>AK-735012</b>		
Control Arm-/Trailing Arm Bush	2.0, 2.3, 2.3 Turbo, 2.4 Diesel, 2.4 TD Interc., 2.4 Turbo-Diesel		<b>F8-5106</b>		H=27; d=18; D=51
Control Arm-/Trailing Arm Bush	2.0, 2.3, 2.3 Turbo, 2.4 Diesel, 2.4 TD Interc., 2.4 Turbo-Diesel		<b>F8-5140</b>		d=14; L=67.5; D=47
Control Arm-/Trailing Arm Bush	2.0	B 200 G	<b>F8-5254</b>		H=27; d=17; D=52
Mounting, stabilizer coupling rod	2.0, 2.3, 2.3 Turbo, 2.4 Diesel, 2.4 TD Interc., 2.4 Turbo-Diesel		<b>F8-5571</b>		H=22.5; d=10; D=32.5
Suspension, panhard rod	2.0, 2.3, 2.3 Turbo, 2.4 Diesel, 2.4 TD Interc., 2.4 Turbo-Diesel		<b>F8-5735</b>		H=40; d=20; D=40.5
Suspension, panhard rod	2.0, 2.3, 2.3 Turbo, 2.4 Diesel, 2.4 TD Interc., 2.4 Turbo-Diesel		<b>F8-5736</b>		H=50; d=12; D=40
Rubber Buffer, suspension	2.0	B 200 G	<b>F8-5899</b>		D=25; H=95
Rubber Buffer, suspension	2.0, 2.0 GLE, 2.0 Turbo, 2.3, 2.3 GL, 2.3 GLE, 2.3 Turbo, 2.4 Diesel, 2.4 TD Interc., 2.4 Turbo-Diesel		<b>F8-5899</b>		D=25; H=95
Top Strut Mounting	2.0	B 200 G;	<b>F8-5983</b>		d=18
Top Strut Mounting	2.0, 2.0 GLE, 2.0 Turbo, 2.3, 2.3 GL, 2.3 GLE, 2.3 Turbo, 2.4 Diesel, 2.4 TD Interc., 2.4 Turbo-Diesel		<b>F8-5983</b>		d=18
Top Strut Mounting	2.0, 2.0 GLE, 2.0 Turbo, 2.3, 2.3 GL, 2.3 GLE, 2.3 Turbo, 2.4 Diesel, 2.4 TD Interc., 2.4 Turbo-Diesel		<b>F8-5984</b>		d=18
Anti-Friction Bearing	2.0, 2.3, 2.3 Turbo, 2.4 Diesel, 2.4 TD Interc., 2.4 Turbo-Diesel		<b>F8-6267</b>		H=12; W=91
Mounting, automatic transmission	2.0, 2.0 16V, 2.0 GLE, 2.0 Turbo, 2.3, 2.3 GL, 2.3 GLE, 2.3 Turbo, 2.4 Diesel, 2.4 TD Interc., 2.4 Turbo-Diesel		<b>F8-6549</b>		
Bearing Bush, stabiliser	2.0, 2.3, 2.3 Turbo, 2.4 Diesel, 2.4 TD Interc., 2.4 Turbo-Diesel		<b>F8-6769</b>		H=53.8; d=20.8
Engine Mounting	2.0, 2.3	Bearing Type: Hard Version; White	<b>F8-7354</b>		

<b>AK-735012</b>	<b>F8-5106</b>	<b>F8-5140</b>	<b>F8-5254</b>	<b>F8-5571</b>	<b>F8-5735</b>	<b>F8-5736</b>
Ref.Nr.:	Ref.Nr.: 013595996	Ref.Nr.: 013296553	Ref.Nr.: 6819057	Ref.Nr.: 1205991	Ref.Nr.: 1330427	Ref.Nr.: 1229715
<b>F8-5899</b>	<b>F8-5983</b>	<b>F8-5984</b>	<b>F8-6267</b>	<b>F8-6549</b>	<b>F8-6769</b>	<b>F8-7354</b>
Ref.Nr.: 1273849	Ref.Nr.: 1387188	Ref.Nr.: 1273747	Ref.Nr.: 1273747	Ref.Nr.: 1328900	Ref.Nr.: 1359808	Ref.Nr.: 1329428
<b>F8-7355</b>						
Ref.Nr.: 1378657						

Article Description



Article Nr.

Fitting Position



<b>740 Kombi (745)</b>				<b>08/1984 → 08/1992</b>	
Engine Mounting	2.0, 2.3, 2.3 Turbo	Bearing Type: Soft Version	<b>F8-7355</b>		
<b>760 (704, 764)</b>				<b>08/1981 → 07/1992</b>	
Dust Cover Kit, shock absorber	2.3 Turbo	05/1984 →	<b>AK-735012</b>		
Dust Cover Kit, shock absorber	2.3 Turbo , 2.4 TD Interc. , 2.4 Turbo Diesel , 2.8		<b>AK-735012</b>		
Control Arm-/Trailing Arm Bush	2.3 Turbo , 2.4 TD Interc. , 2.4 Turbo Diesel , 2.8		<b>F8-5106</b>		H=27; d=18; D=51
Control Arm-/Trailing Arm Bush	2.3 Turbo , 2.8	01/1985 →	<b>F8-5106</b>		H=27; d=18; D=51
Control Arm-/Trailing Arm Bush	2.3 Turbo , 2.4 TD Interc. , 2.4 Turbo Diesel , 2.8		<b>F8-5140</b>		d=14; L=67.5; D=47
Control Arm-/Trailing Arm Bush	2.3 Turbo , 2.8	01/1985 →	<b>F8-5140</b>		d=14; L=67.5; D=47
Mounting, stabilizer coupling rod	2.3 Turbo , 2.4 TD Interc. , 2.4 Turbo Diesel , 2.8		<b>F8-5571</b>		H=22.5; d=10; D=32.5
Suspension, panhard rod	2.3 Turbo , 2.4 TD Interc. , 2.4 Turbo Diesel , 2.8		<b>F8-5735</b>		H=40; d=20; D=40.5
Suspension, panhard rod	2.3 Turbo , 2.4 TD Interc. , 2.4 Turbo Diesel , 2.8		<b>F8-5736</b>		H=50; d=12; D=40
Rubber Buffer, suspension	2.3, 2.3 Turbo, 2.4 TD Interc. , 2.4 Turbo Diesel , 2.8		<b>F8-5899</b>		D=25; H=95
Top Strut Mounting	2.3, 2.3 Turbo, 2.4 TD Interc. , 2.4 Turbo Diesel , 2.8		<b>F8-5983</b>		d=18
Top Strut Mounting	2.3, 2.3 Turbo, 2.4 TD Interc. , 2.4 Turbo Diesel , 2.8		<b>F8-5984</b>		d=18
Anti-Friction Bearing	2.3 Turbo , 2.4 TD Interc. , 2.4 Turbo Diesel , 2.8		<b>F8-6267</b>		H=12; W=91
Mounting, automatic transmission	All Models		<b>F8-6549</b>		
Bearing Bush, stabiliser	2.3, 2.3 Turbo , 2.4 D, 2.4 TD Interc. , 2.4 Turbo Diesel , 2.8		<b>F8-6769</b>		H=53.8; d=20.8
Engine Mounting	2.3 Turbo	Bearing Type: Soft Version	<b>F8-7355</b>		
<b>760 Kombi (704, 765)</b>				<b>01/1982 → 07/1992</b>	
Dust Cover Kit, shock absorber	2.4 TD Interc. , 2.8		<b>AK-735012</b>		
Control Arm-/Trailing Arm Bush	2.4 TD Interc. , 2.8		<b>F8-5106</b>		H=27; d=18; D=51
Control Arm-/Trailing Arm Bush	2.4 TD Interc. , 2.8		<b>F8-5140</b>		d=14; L=67.5; D=47
Mounting, stabilizer coupling rod	2.4 TD Interc. , 2.8		<b>F8-5571</b>		H=22.5; d=10; D=32.5
Suspension, panhard rod	2.4 TD Interc. , 2.8		<b>F8-5735</b>		H=40; d=20; D=40.5
Suspension, panhard rod	2.4 TD Interc. , 2.8		<b>F8-5736</b>		H=50; d=12; D=40
Rubber Buffer, suspension	2.3 Turbo, 2.4 TD Interc. , 2.8		<b>F8-5899</b>		D=25; H=95
Top Strut Mounting	2.3, 2.3 Turbo, 2.4 TD Interc. , 2.8		<b>F8-5983</b>		d=18
Top Strut Mounting	2.3, 2.3 Turbo, 2.4 TD Interc. , 2.8		<b>F8-5984</b>		d=18
Anti-Friction Bearing	2.3 Turbo, 2.4 TD Interc. , 2.8		<b>F8-6267</b>		H=12; W=91



**Article Description****Article Nr.****Fitting Position**

<b>760 Kombi (704, 765)</b>				<b>01/1982 → 07/1992</b>	
Mounting, automatic transmission	All Models		<b>F8-6549</b>		
Bearing Bush, stabiliser	2.3 Turbo, 2.4 D, 2.4 TD Interc. , 2.8		<b>F8-6769</b>		H=53.8; d=20.8
<b>780</b>				<b>04/1986 → 07/1990</b>	
Dust Cover Kit, shock absorber	2.9		<b>AK-735012</b>		
Control Arm-/Trailing Arm Bush	2.9		<b>F8-5106</b>		H=27; d=18; D=51
Control Arm-/Trailing Arm Bush	All Models		<b>F8-5254</b>		H=27; d=17; D=52
Mounting, stabilizer coupling rod	2.9		<b>F8-5571</b>		H=22.5; d=10; D=32.5
Suspension, panhard rod	2.9		<b>F8-5735</b>		H=40; d=20; D=40.5
Suspension, panhard rod	2.9		<b>F8-5736</b>		H=50; d=12; D=40
Top Strut Mounting	2.9		<b>F8-5983</b>		d=18
Top Strut Mounting	2.9		<b>F8-5984</b>		d=18
Anti-Friction Bearing	2.9		<b>F8-6267</b>		H=12; W=91
Bearing Bush, stabiliser	2.9		<b>F8-6769</b>		H=53.8; d=20.8
<b>850 (LS)</b>				<b>06/1991 → 10/1997</b>	
Dust Cover Kit, shock absorber	2.0, 2.0 Turbo, 2.3, 2.3 T5, 2.3 T5 R, 2.3 T5-R, 2.3 Turbo R, 2.4 GLE, 2.5, 2.5 TDI		<b>AK-735003</b>		
Alternator Freewheel Clutch	2.0 Turbo, 2.3, 2.3 T5, 2.3 T5 R, 2.3 T5-R, 2.3 Turbo R, 2.4 GLE		<b>F5-1015</b>		
Mounting, automatic transmission	2.0, 2.0 Turbo, 2.3 T5, 2.3 T5-R, 2.5, 2.5 TDI		<b>F8-5027</b>		H=59; d=12.2; D=60.5
Top Strut Mounting	2.0, 2.0 Turbo, 2.3, 2.3 T5, 2.3 T5 R, 2.3 T5-R, 2.3 Turbo R, 2.4 GLE, 2.5, 2.5 TDI		<b>F8-5570</b>		
Top Strut Mounting	2.0, 2.0 Turbo, 2.3, 2.3 T5, 2.3 T5 R, 2.3 T5-R, 2.3 Turbo R, 2.4 GLE, 2.5, 2.5 TDI		<b>F8-5915</b>		
Rubber Buffer, suspension	2.0 Turbo, 2.4 GLE	01/1994 →	<b>F8-5919</b>		D=20; H=51
Rubber Buffer, suspension	2.0, 2.0 Turbo, 2.3, 2.3 T5, 2.3 T5 R, 2.3 T5-R, 2.3 Turbo R, 2.5, 2.5 TDI		<b>F8-5919</b>		D=20; H=51
Rubber Buffer, suspension	2.0, 2.0 Turbo, 2.3 T5, 2.5, 2.5 TDI		<b>F8-5920</b>		D=20; H=40
Rubber Buffer, suspension	2.4 GLE	01/1994 →	<b>F8-5920</b>		D=20; H=40
Rubber Buffer, suspension	2.0, 2.0 Turbo, 2.3 T5, 2.4 GLE, 2.5, 2.5 TDI		<b>F8-5921</b>		D=17; H=95
Rubber Buffer, suspension	2.0, 2.0 Turbo, 2.3 T5, 2.4 GLE, 2.5, 2.5 TDI		<b>F8-5922</b>		D=32; H=160
Top Strut Mounting	2.0		<b>F8-5929</b>		H=32; d=13.5
Top Strut Mounting	2.0, 2.0 Turbo, 2.3, 2.3 T5, 2.3 T5 R, 2.3 T5-R, 2.3 Turbo R, 2.4 GLE, 2.5, 2.5 TDI		<b>F8-5929</b>		H=32; d=13.5
Repair Kit, suspension strut	2.0, 2.0 Turbo, 2.3 T5, 2.3 T5-R, 2.5, 2.5 TDI		<b>F8-6385</b>		

<b>AK-735003</b>	<b>AK-735012</b>	<b>F5-1015</b>	<b>F8-5027</b>	<b>F8-5106</b>	<b>F8-5254</b>	<b>F8-5570</b>
Ref.Nr.:	Ref.Nr.:	Ref.Nr.: 9404328	Ref.Nr.: 9434263	Ref.Nr.: 013595996	Ref.Nr.: 6819057	Ref.Nr.: 9461728
<b>F8-5571</b>	<b>F8-5735</b>	<b>F8-5736</b>	<b>F8-5915</b>	<b>F8-5919</b>	<b>F8-5920</b>	<b>F8-5921</b>
Ref.Nr.: 1205991	Ref.Nr.: 1330427	Ref.Nr.: 1229715	Ref.Nr.: 31200599	Ref.Nr.: 9140067	Ref.Nr.: 9140129	Ref.Nr.: 3516327
<b>F8-5922</b>	<b>F8-5929</b>	<b>F8-5983</b>	<b>F8-5984</b>	<b>F8-6267</b>	<b>F8-6385</b>	<b>F8-6548</b>
Ref.Nr.: 3546705	Ref.Nr.: 3516151	Ref.Nr.: 1387188	Ref.Nr.: 1273747	Ref.Nr.: 1273747	Ref.Nr.: 9173203	Ref.Nr.: 271631

Article Description			Article Nr.	Fitting Position	
---------------------	--	--	-------------	------------------	--

<b>850 (LS)</b>		<b>06/1991 → 10/1997</b>			
Control Arm-/Trailing Arm Bush	2.0, 2.0 Turbo, 2.3 T5, 2.3 T5-R, 2.5, 2.5 TDI		<b>F8-6548</b>		
Mounting, axle beam	2.0, 2.0 Turbo, 2.3, 2.3 T5, 2.3 T5 R, 2.3 T5-R, 2.3 Turbo R, 2.4 GLE, 2.5, 2.5 TDI		<b>F8-6759</b>		
Control Arm-/Trailing Arm Bush	2.0, 2.0 Turbo, 2.3, 2.3 T5, 2.3 T5 R, 2.3 T5-R, 2.3 Turbo R, 2.4 GLE, 2.5, 2.5 TDI		<b>F8-7694</b>		
Control Arm-/Trailing Arm Bush	2.0, 2.0 Turbo, 2.3, 2.3 T5, 2.3 T5 R, 2.3 T5-R, 2.3 Turbo R, 2.4 GLE, 2.5, 2.5 TDI	Aluminium	<b>F8-7695</b>		
Suspension Kit	2.0, 2.0 Turbo, 2.3, 2.3 T5, 2.3 T5 R, 2.3 T5-R, 2.3 Turbo R, 2.4 GLE, 2.5, 2.5 TDI	Aluminium; with fastening material	<b>F8-7695S</b>		
Control Arm-/Trailing Arm Bush	2.0, 2.0 Turbo, 2.3, 2.3 T5, 2.3 T5 R, 2.3 T5-R, 2.3 Turbo R, 2.4 GLE, 2.5, 2.5 TDI	Aluminium	<b>F8-7696</b>		
Suspension Kit	2.0, 2.0 Turbo, 2.3, 2.3 T5, 2.3 T5 R, 2.3 T5-R, 2.3 Turbo R, 2.4 GLE, 2.5, 2.5 TDI	Aluminium; with fastening material	<b>F8-7696S</b>		
Engine Mounting	2.0, 2.0 Turbo, 2.3, 2.3 T5, 2.3 T5 R, 2.3 T5-R, 2.3 Turbo R, 2.4 GLE, 2.5		<b>F8-8148</b>		
Engine Mounting	2.0 Turbo, 2.3 T5, 2.3 T5-R		<b>F8-8190</b>		

<b>850 Estate (LW)</b>		<b>08/1992 → 10/1997</b>			
Dust Cover Kit, shock absorber	All Models		<b>AK-735003</b>		
Alternator Freewheel Clutch	2.0 Turbo, 2.3, 2.3 T5, 2.3 T5 R, 2.3 T5-R, 2.3 Turbo R, 2.4 GLE, 2.5 AWD		<b>F5-1015</b>		
Mounting, automatic transmission	2.0, 2.0 Turbo, 2.3 T5, 2.3 T5-R, 2.5, 2.5 AWD, 2.5 TDI		<b>F8-5027</b>		H=59; d=12.2; D=60.5
Control Arm-/Trailing Arm Bush	2.5 AWD		<b>F8-5254</b>		H=27; d=17; D=52
Top Strut Mounting	All Models		<b>F8-5570</b>		
Top Strut Mounting	All Models		<b>F8-5915</b>		
Rubber Buffer, suspension	2.0 Turbo, 2.4 GLE	01/1994 →	<b>F8-5919</b>		D=20; H=51
Rubber Buffer, suspension	2.0, 2.0 Turbo, 2.3, 2.3 T5, 2.3 T5 R, 2.3 T5-R, 2.3 Turbo R, 2.5, 2.5 AWD, 2.5 TDI		<b>F8-5919</b>		D=20; H=51
Rubber Buffer, suspension	2.0, 2.0 Turbo, 2.5, 2.5 TDI		<b>F8-5920</b>		D=20; H=40
Rubber Buffer, suspension	2.0, 2.0 Turbo, 2.5		<b>F8-5921</b>		D=17; H=95
Rubber Buffer, suspension	2.0, 2.0 Turbo, 2.5		<b>F8-5922</b>		D=32; H=160
Top Strut Mounting	2.0, 2.0 Turbo, 2.3 T5, 2.3 T5 R, 2.3 T5-R, 2.3 Turbo R, 2.4 GLE, 2.5, 2.5 AWD, 2.5 TDI		<b>F8-5929</b>		H=32; d=13.5
Top Strut Mounting	2.3		<b>F8-5929</b>		H=32; d=13.5
Repair Kit, suspension strut	2.0, 2.0 Turbo, 2.3 T5, 2.3 T5-R, 2.5, 2.5 AWD, 2.5 TDI		<b>F8-6385</b>		
Control Arm-/Trailing Arm Bush	2.0, 2.0 Turbo, 2.3 T5, 2.3 T5-R, 2.5, 2.5 AWD, 2.5 TDI		<b>F8-6548</b>		
Mounting, axle beam	All Models		<b>F8-6759</b>		

<b>AK-735003</b>	<b>F5-1015</b>	<b>F8-5027</b>	<b>F8-5254</b>	<b>F8-5570</b>	<b>F8-5915</b>	<b>F8-5919</b>
Ref.Nr.: <b>9404328</b>	Ref.Nr.: <b>9404328</b>	Ref.Nr.: <b>9434263</b>	Ref.Nr.: <b>6819057</b>	Ref.Nr.: <b>9461728</b>	Ref.Nr.: <b>31200599</b>	Ref.Nr.: <b>9140067</b>
<b>F8-5920</b>	<b>F8-5921</b>	<b>F8-5922</b>	<b>F8-5929</b>	<b>F8-6385</b>	<b>F8-6548</b>	<b>F8-6759</b>
Ref.Nr.: <b>9140129</b>	Ref.Nr.: <b>3516327</b>	Ref.Nr.: <b>3546705</b>	Ref.Nr.: <b>3516151</b>	Ref.Nr.: <b>9173203</b>	Ref.Nr.: <b>271631</b>	Ref.Nr.: <b>3507924</b>
<b>F8-7694</b>	<b>F8-7695</b>	<b>F8-7695S</b>	<b>F8-7696</b>	<b>F8-7696S</b>	<b>F8-8148</b>	<b>F8-8190</b>
Ref.Nr.: <b>3530050</b>	Ref.Nr.: <b>3530202</b>	Ref.Nr.: <b>3530202</b>	Ref.Nr.: <b>3516496</b>	Ref.Nr.: <b>3516496</b>	Ref.Nr.: <b>8659000</b>	Ref.Nr.: <b>8631698</b>

**Article Description****Article Nr.****Fitting Position****850 Estate (LW)****08/1992 → 10/1997**

Control Arm-/Trailing Arm Bush	2.0, 2.0 Turbo, 2.3, 2.3 T5, 2.3 T5 R, 2.3 T5-R, 2.3 Turbo R, 2.4 GLE, 2.5, 2.5 TDI		<b>F8-7694</b>		
Control Arm-/Trailing Arm Bush	2.0, 2.0 Turbo, 2.3, 2.3 T5, 2.3 T5 R, 2.3 T5-R, 2.3 Turbo R, 2.4 GLE, 2.5, 2.5 TDI	Aluminium	<b>F8-7695</b>		
Suspension Kit	2.0, 2.0 Turbo, 2.3, 2.3 T5, 2.3 T5 R, 2.3 T5-R, 2.3 Turbo R, 2.4 GLE, 2.5, 2.5 TDI	Aluminium; with fastening material	<b>F8-7695S</b>		
Control Arm-/Trailing Arm Bush	2.0, 2.0 Turbo, 2.3, 2.3 T5, 2.3 T5 R, 2.3 T5-R, 2.3 Turbo R, 2.4 GLE, 2.5, 2.5 TDI	Aluminium	<b>F8-7696</b>		
Suspension Kit	2.0, 2.0 Turbo, 2.3, 2.3 T5, 2.3 T5 R, 2.3 T5-R, 2.3 Turbo R, 2.4 GLE, 2.5, 2.5 TDI	Aluminium; with fastening material	<b>F8-7696S</b>		
Engine Mounting	2.0, 2.0 Turbo, 2.3, 2.3 T5, 2.3 T5 R, 2.3 T5-R, 2.3 Turbo R, 2.4 GLE, 2.5		<b>F8-8148</b>		
Engine Mounting	2.0 Turbo, 2.3 T5, 2.3 T5-R		<b>F8-8190</b>		

**940 (944)****08/1990 → 12/1994**

Dust Cover Kit, shock absorber	2.0, 2.3, 2.3 Turbo, 2.4 TD Intercooler, 2.4 Turbo Diesel		<b>AK-735012</b>		
Control Arm-/Trailing Arm Bush	2.0, 2.3, 2.3 Turbo, 2.4 D, 2.4 TD Intercooler, 2.4 Turbo Diesel		<b>F8-5106</b>		H=27; d=18; D=51
Control Arm-/Trailing Arm Bush	2.0, 2.3, 2.3 Turbo, 2.4 TD Intercooler, 2.4 Turbo Diesel		<b>F8-5140</b>		d=14; L=67.5; D=47
Control Arm-/Trailing Arm Bush	2.0, 2.0 Turbo, 2.3 Turbo, 2.4 D, 2.4 TD Intercooler, 2.4 Turbo Diesel		<b>F8-5254</b>		H=27; d=17; D=52
Control Arm-/Trailing Arm Bush	2.3	B 230 E	<b>F8-5254</b>		H=27; d=17; D=52
Control Arm-/Trailing Arm Bush	2.3	B 230 FB	<b>F8-5254</b>		H=27; d=17; D=52
Control Arm-/Trailing Arm Bush	2.3	B 234 F	<b>F8-5254</b>		H=27; d=17; D=52
Control Arm-/Trailing Arm Bush	2.3	B 234 G	<b>F8-5254</b>		H=27; d=17; D=52
Mounting, stabilizer coupling rod	2.0, 2.0 GL, 2.3, 2.3 Turbo, 2.4 TD Intercooler, 2.4 Turbo Diesel		<b>F8-5571</b>		H=22.5; d=10; D=32.5
Suspension, panhard rod	2.0, 2.0 GL, 2.3, 2.3 Turbo, 2.4 D, 2.4 TD Intercooler, 2.4 Turbo Diesel		<b>F8-5735</b>		H=40; d=20; D=40.5
Suspension, panhard rod	2.0, 2.0 GL, 2.3, 2.3 Turbo, 2.4 D, 2.4 TD Intercooler, 2.4 Turbo Diesel		<b>F8-5736</b>		H=50; d=12; D=40
Rubber Buffer, suspension	2.0, 2.3, 2.3 Turbo, 2.4 TD Intercooler, 2.4 Turbo Diesel		<b>F8-5899</b>		D=25; H=95
Top Strut Mounting	2.0, 2.0 GL, 2.0 Turbo, 2.3, 2.3 Turbo, 2.4 D, 2.4 TD Intercooler, 2.4 Turbo Diesel		<b>F8-5983</b>		d=18
Top Strut Mounting	2.0, 2.0 GL, 2.0 Turbo, 2.3, 2.3 Turbo, 2.4 D, 2.4 TD Intercooler, 2.4 Turbo Diesel		<b>F8-5984</b>		d=18
Anti-Friction Bearing	2.0, 2.3, 2.4 D		<b>F8-6267</b>		H=12; W=91

<b>AK-735012</b>	<b>F8-5106</b>	<b>F8-5140</b>	<b>F8-5254</b>	<b>F8-5571</b>	<b>F8-5735</b>	<b>F8-5736</b>
Ref.Nr.:	Ref.Nr.: 013595996	Ref.Nr.: 013296553	Ref.Nr.: 6819057	Ref.Nr.: 1205991	Ref.Nr.: 1330427	Ref.Nr.: 1229715
<b>F8-5899</b>	<b>F8-5983</b>	<b>F8-5984</b>	<b>F8-6267</b>	<b>F8-6549</b>	<b>F8-7694</b>	<b>F8-7695</b>
Ref.Nr.: 1273849	Ref.Nr.: 1387188	Ref.Nr.: 1273747	Ref.Nr.: 1273747	Ref.Nr.: 1328900	Ref.Nr.: 3530050	Ref.Nr.: 3530202
<b>F8-7695S</b>	<b>F8-7696</b>	<b>F8-7696S</b>	<b>F8-8148</b>	<b>F8-8190</b>		
Ref.Nr.: 3530202	Ref.Nr.: 3516496	Ref.Nr.: 3516496	Ref.Nr.: 8659000	Ref.Nr.: 8631698		

<b>Article Description</b>			<b>Article Nr.</b>	<b>Fitting Position</b>	
----------------------------	--	--	--------------------	-------------------------	--

<b>940 (944)</b>			<b>08/1990 → 12/1994</b>		
Mounting, automatic transmission	2.0, 2.0 GL, 2.3, 2.3 Turbo, 2.4 D, 2.4 TD Intercooler, 2.4 Turbo Diesel		<b>F8-6549</b>		
Bearing Bush, stabiliser	2.0, 2.0 Turbo, 2.3, 2.3 Turbo, 2.4 D, 2.4 TD Intercooler, 2.4 Turbo Diesel		<b>F8-6769</b>		H=53.8; d=20.8
Engine Mounting	2.3	Bearing Type: Hard Version; White	<b>F8-7354</b>		
Engine Mounting	2.3	Bearing Type: Soft Version	<b>F8-7355</b>		
<b>940 Kombi (945)</b>			<b>08/1990 → 07/1995</b>		
Dust Cover Kit, shock absorber	2.0, 2.3, 2.3 Turbo, 2.4 Turbo Diesel		<b>AK-735012</b>		
Control Arm-/Trailing Arm Bush	2.0, 2.0 Turbo, 2.3, 2.3 Turbo, 2.4 D, 2.4 Turbo Diesel		<b>F8-5106</b>		H=27; d=18; D=51
Control Arm-/Trailing Arm Bush	2.0, 2.0 Turbo, 2.3, 2.3 Turbo, 2.4 D, 2.4 Turbo Diesel		<b>F8-5140</b>		d=14; L=67.5; D=47
Control Arm-/Trailing Arm Bush	2.0, 2.0 Turbo, 2.3, 2.3 Turbo, 2.4 D, 2.4 TD Intercooler, 2.4 Turbo Diesel		<b>F8-5254</b>		H=27; d=17; D=52
Mounting, stabilizer coupling rod	2.0, 2.0 GL, 2.0 Turbo, 2.3, 2.3 Turbo, 2.4 D, 2.4 Turbo Diesel		<b>F8-5571</b>		H=22.5; d=10; D=32.5
Suspension, panhard rod	2.0, 2.0 GL, 2.0 Turbo, 2.3, 2.3 Turbo, 2.4 D, 2.4 Turbo Diesel		<b>F8-5735</b>		H=40; d=20; D=40.5
Suspension, panhard rod	2.0, 2.0 GL, 2.0 Turbo, 2.3, 2.3 Turbo, 2.4 D, 2.4 TD Intercooler, 2.4 Turbo Diesel		<b>F8-5736</b>		H=50; d=12; D=40
Rubber Buffer, suspension	2.0, 2.0 Turbo, 2.3, 2.3 Turbo, 2.4 D, 2.4 Turbo Diesel		<b>F8-5899</b>		D=25; H=95
Top Strut Mounting	2.0, 2.0 GL, 2.0 Turbo, 2.3, 2.3 Turbo, 2.4 D, 2.4 TD Intercooler, 2.4 Turbo Diesel		<b>F8-5983</b>		d=18
Top Strut Mounting	2.0, 2.0 GL, 2.0 Turbo, 2.3, 2.3 Turbo, 2.4 D, 2.4 TD Intercooler, 2.4 Turbo Diesel		<b>F8-5984</b>		d=18
Anti-Friction Bearing	2.0, 2.0 Turbo, 2.3, 2.4 D		<b>F8-6267</b>		H=12; W=91
Mounting, automatic transmission	All Models		<b>F8-6549</b>		
Bearing Bush, stabiliser	2.0, 2.3, 2.3 Turbo, 2.4 D, 2.4 TD Intercooler, 2.4 Turbo Diesel		<b>F8-6769</b>		H=53.8; d=20.8
Engine Mounting	2.0 Turbo, 2.3	Bearing Type: Hard Version; White	<b>F8-7354</b>		
Engine Mounting	2.0 Turbo, 2.3	Bearing Type: Soft Version	<b>F8-7355</b>		
<b>940 Mk II (944)</b>			<b>08/1994 → 10/1998</b>		
Dust Cover Kit, shock absorber	2.3, 2.3 ti, 2.3 Turbo, 2.4 TD Interc.		<b>AK-735012</b>		
Control Arm-/Trailing Arm Bush	2.3, 2.3 ti, 2.3 Turbo, 2.4 TD Interc.		<b>F8-5106</b>		H=27; d=18; D=51
Control Arm-/Trailing Arm Bush	2.0 Turbo, 2.3, 2.3 ti		<b>F8-5140</b>		d=14; L=67.5; D=47
Control Arm-/Trailing Arm Bush	2.0, 2.0 Turbo, 2.3, 2.3 ti, 2.3 Turbo, 2.4 TD Interc.		<b>F8-5254</b>		H=27; d=17; D=52
Mounting, stabilizer coupling rod	2.0 GLT, 2.0 Turbo, 2.3, 2.3 ti		<b>F8-5571</b>		H=22.5; d=10; D=32.5

<b>AK-735012</b>	<b>F8-5106</b>	<b>F8-5140</b>	<b>F8-5254</b>	<b>F8-5571</b>	<b>F8-5735</b>	<b>F8-5736</b>
Ref.Nr.:	Ref.Nr.: 013595996	Ref.Nr.: 013296553	Ref.Nr.: 6819057	Ref.Nr.: 1205991	Ref.Nr.: 1330427	Ref.Nr.: 1229715
<b>F8-5899</b>	<b>F8-5983</b>	<b>F8-5984</b>	<b>F8-6267</b>	<b>F8-6549</b>	<b>F8-6769</b>	<b>F8-7354</b>
Ref.Nr.: 1273849	Ref.Nr.: 1387188	Ref.Nr.: 1273747	Ref.Nr.: 1273747	Ref.Nr.: 1328900	Ref.Nr.: 1359808	Ref.Nr.: 1329428
<b>F8-7355</b>						
Ref.Nr.: 1378657						

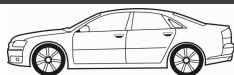

**Article Description****Article Nr.****Fitting Position**

<b>940 Mk II (944)</b>			<b>08/1994 → 10/1998</b>		
Suspension, panhard rod	2.0 GLT, 2.0 Turbo, 2.3, 2.3 ti		<b>F8-5735</b>		H=40; d=20; D=40.5
Suspension, panhard rod	2.0 GLT, 2.0 Turbo, 2.3, 2.3 ti, 2.3 Turbo, 2.4 TD Interc.		<b>F8-5736</b>		H=50; d=12; D=40
Rubber Buffer, suspension	2.0 GLT, 2.3, 2.3 Turbo, 2.4 TD Interc.		<b>F8-5899</b>		D=25; H=95
Rubber Buffer, suspension	2.3	01/1995 →	<b>F8-5899</b>		D=25; H=95
Top Strut Mounting	2.0, 2.0 GLT, 2.0 Turbo, 2.3, 2.3 ti, 2.3 Turbo, 2.4 TD Interc.		<b>F8-5983</b>		d=18
Top Strut Mounting	2.0, 2.0 GLT, 2.0 Turbo, 2.3, 2.3 ti, 2.3 Turbo, 2.4 TD Interc.		<b>F8-5984</b>		d=18
Anti-Friction Bearing	2.0 Turbo, 2.3, 2.3 Turbo, 2.4 TD Interc.		<b>F8-6267</b>		H=12; W=91
Mounting, automatic transmission	2.0, 2.0 GLT, 2.0 Turbo, 2.3, 2.3 ti, 2.3 Turbo, 2.4 TD Interc.		<b>F8-6549</b>		
Bearing Bush, stabiliser	2.0 Turbo, 2.3, 2.3 ti, 2.3 Turbo, 2.4 TD Interc.		<b>F8-6769</b>		H=53.8; d=20.8
Engine Mounting	2.0 GLT, 2.0 Turbo, 2.3	Bearing Type: Hard Version; White	<b>F8-7354</b>		
Engine Mounting	2.0 GLT, 2.0 Turbo, 2.3	Bearing Type: Soft Version	<b>F8-7355</b>		
<b>940 Mk II Estate (945)</b>			<b>08/1994 → 10/1998</b>		
Dust Cover Kit, shock absorber	2.3, 2.3 ti, 2.3 Turbo, 2.4 TD Interc.		<b>AK-735012</b>		
Control Arm-/Trailing Arm Bush	2.3, 2.3 ti, 2.3 Turbo, 2.4 TD Interc.		<b>F8-5106</b>		H=27; d=18; D=51
Control Arm-/Trailing Arm Bush	2.0 Turbo, 2.3, 2.3 ti, 2.3 Turbo, 2.4 TD Interc.		<b>F8-5140</b>		d=14; L=67.5; D=47
Control Arm-/Trailing Arm Bush	2.0, 2.0 Turbo, 2.3, 2.3 ti, 2.3 Turbo, 2.4 TD Interc.		<b>F8-5254</b>		H=27; d=17; D=52
Mounting, stabilizer coupling rod	2.0 GLT, 2.0 Turbo, 2.3, 2.3 ti, 2.3 Turbo, 2.4 TD Interc.		<b>F8-5571</b>		H=22.5; d=10; D=32.5
Suspension, panhard rod	2.0 GLT, 2.0 Turbo, 2.3, 2.3 ti, 2.4 TD Interc.		<b>F8-5735</b>		H=40; d=20; D=40.5
Suspension, panhard rod	2.0 GLT, 2.0 Turbo, 2.3, 2.3 ti, 2.4 TD Interc.		<b>F8-5736</b>		H=50; d=12; D=40
Rubber Buffer, suspension	2.0, 2.0 GLT, 2.3, 2.3 Turbo		<b>F8-5899</b>		D=25; H=95
Rubber Buffer, suspension	2.3, 2.4 TD Interc.	01/1995 →	<b>F8-5899</b>		D=25; H=95
Top Strut Mounting	2.0, 2.0 GLT, 2.0 Turbo, 2.3, 2.3 ti, 2.3 Turbo, 2.4 TD Interc.		<b>F8-5983</b>		d=18
Top Strut Mounting	2.0, 2.0 GLT, 2.0 Turbo, 2.3, 2.3 ti, 2.3 Turbo, 2.4 TD Interc.		<b>F8-5984</b>		d=18
Anti-Friction Bearing	2.0 Turbo, 2.3, 2.3 ti, 2.3 Turbo		<b>F8-6267</b>		H=12; W=91
Mounting, automatic transmission	All Models		<b>F8-6549</b>		
Bearing Bush, stabiliser	2.0 Turbo, 2.3, 2.3 ti, 2.3 Turbo, 2.4 TD Interc.		<b>F8-6769</b>		H=53.8; d=20.8
Engine Mounting	2.0 GLT, 2.3	Bearing Type: Hard Version; White	<b>F8-7354</b>		
Engine Mounting	2.0 GLT, 2.3	Bearing Type: Soft Version	<b>F8-7355</b>		



Article Description			Article Nr.	Fitting Position	
---------------------	--	--	-------------	------------------	--

<b>960 (964)</b>			<b>08/1990 → 07/1994</b>		
Dust Cover Kit, shock absorber	2.4 TD Interc.		<b>AK-735012</b>		
Dust Cover Kit, shock absorber	2.9	ch.→R048299	<b>AK-735012</b>		
Control Arm-/Trailing Arm Bush	2.4 TD Interc., 2.9		<b>F8-5106</b>		H=27; d=18; D=51
Control Arm-/Trailing Arm Bush	2.4 TD Interc., 2.9		<b>F8-5140</b>		d=14; L=67.5; D=47
Control Arm-/Trailing Arm Bush	2.0, 2.3 Turbo, 2.4 TD Interc., 2.8 GL, 2.9		<b>F8-5254</b>		H=27; d=17; D=52
Mounting, stabilizer coupling rod	2.0, 2.4 TD Interc., 2.8 GL, 2.9		<b>F8-5571</b>		H=22.5; d=10; D=32.5
Suspension, panhard rod	2.0, 2.4 TD Interc., 2.8 GL, 2.9		<b>F8-5735</b>		H=40; d=20; D=40.5
Suspension, panhard rod	2.0, 2.4 TD Interc., 2.8 GL, 2.9		<b>F8-5736</b>		H=50; d=12; D=40
Rubber Buffer, suspension	All Models		<b>F8-5899</b>		D=25; H=95
Top Strut Mounting	All Models		<b>F8-5983</b>		d=18
Top Strut Mounting	All Models		<b>F8-5984</b>		d=18
Anti-Friction Bearing	2.0, 2.4 TD Interc., 2.9		<b>F8-6267</b>		H=12; W=91
Mounting, automatic transmission	All Models		<b>F8-6549</b>		
Bearing Bush, stabiliser	2.0, 2.4 TD Interc., 2.9		<b>F8-6769</b>		H=53.8; d=20.8
Engine Mounting	2.0	Bearing Type: Soft Version	<b>F8-7355</b>		

<b>960 Kombi (965)</b>			<b>08/1990 → 07/1994</b>		
Dust Cover Kit, shock absorber	2.4 TD Interc.		<b>AK-735012</b>		
Dust Cover Kit, shock absorber	2.9	ch.→R018099	<b>AK-735012</b>		
Control Arm-/Trailing Arm Bush	2.4 TD Interc., 2.9		<b>F8-5106</b>		H=27; d=18; D=51
Control Arm-/Trailing Arm Bush	2.4 TD Interc., 2.9		<b>F8-5140</b>		d=14; L=67.5; D=47
Control Arm-/Trailing Arm Bush	All Models		<b>F8-5254</b>		H=27; d=17; D=52
Mounting, stabilizer coupling rod	2.0, 2.4 TD Interc., 2.8, 2.9		<b>F8-5571</b>		H=22.5; d=10; D=32.5
Suspension, panhard rod	2.0, 2.4 TD Interc., 2.8, 2.9		<b>F8-5735</b>		H=40; d=20; D=40.5
Suspension, panhard rod	2.0, 2.4 TD Interc., 2.8, 2.9		<b>F8-5736</b>		H=50; d=12; D=40
Rubber Buffer, suspension	All Models		<b>F8-5899</b>		D=25; H=95
Top Strut Mounting	All Models		<b>F8-5983</b>		d=18
Top Strut Mounting	All Models		<b>F8-5984</b>		d=18
Anti-Friction Bearing	2.0, 2.4 TD Interc., 2.9		<b>F8-6267</b>		H=12; W=91
Mounting, automatic transmission	2.0, 2.3 Turbo, 2.4 TD Interc., 2.4 Tdi, 2.8, 2.9		<b>F8-6549</b>		

<b>AK-735012</b>	<b>F8-5106</b>	<b>F8-5140</b>	<b>F8-5254</b>	<b>F8-5571</b>	<b>F8-5735</b>	<b>F8-5736</b>
Ref.Nr.:	Ref.Nr.: 013595996	Ref.Nr.: 013296553	Ref.Nr.: 6819057	Ref.Nr.: 1205991	Ref.Nr.: 1330427	Ref.Nr.: 1229715
<b>F8-5899</b>	<b>F8-5983</b>	<b>F8-5984</b>	<b>F8-6267</b>	<b>F8-6549</b>	<b>F8-6769</b>	<b>F8-7355</b>
Ref.Nr.: 1273849	Ref.Nr.: 1387188	Ref.Nr.: 1273747	Ref.Nr.: 1273747	Ref.Nr.: 1328900	Ref.Nr.: 1359808	Ref.Nr.: 1378657

**Article Description****Article Nr.****Fitting Position**

<b>960 Kombi (965)</b>				<b>08/1990 → 07/1994</b>	
Bearing Bush, stabiliser	2.0, 2.4 TD Interc., 2.9		<b>F8-6769</b>		H=53.8; d=20.8
<b>960 Mk II (964)</b>				<b>07/1994 → 12/1996</b>	
Dust Cover Kit, shock absorber	2.5	ch.→R048299	<b>AK-735012</b>		
Control Arm-/Trailing Arm Bush	All Models		<b>F8-5106</b>		H=27; d=18; D=51
Control Arm-/Trailing Arm Bush	All Models		<b>F8-5140</b>		d=14; L=67.5; D=47
Control Arm-/Trailing Arm Bush	2.5	01/1995 →	<b>F8-5242</b>		H=65; d=12; D1=21; D2=40
Control Arm-/Trailing Arm Bush	2.9	08/1995 →	<b>F8-5242</b>		H=65; d=12; D1=21; D2=40
Control Arm-/Trailing Arm Bush	All Models		<b>F8-5245</b>		
Control Arm-/Trailing Arm Bush	All Models		<b>F8-5254</b>		H=27; d=17; D=52
Mounting, stabilizer coupling rod	All Models		<b>F8-5571</b>		H=22.5; d=10; D=32.5
Suspension, panhard rod	All Models		<b>F8-5735</b>		H=40; d=20; D=40.5
Suspension, panhard rod	All Models		<b>F8-5736</b>		H=50; d=12; D=40
Rubber Buffer, suspension	All Models		<b>F8-5899</b>		D=25; H=95
Top Strut Mounting	All Models		<b>F8-5983</b>		d=18
Top Strut Mounting	All Models		<b>F8-5984</b>		d=18
Anti-Friction Bearing	All Models		<b>F8-6267</b>		H=12; W=91
Mounting, automatic transmission	All Models		<b>F8-6549</b>		
Bearing Bush, stabiliser	All Models		<b>F8-6769</b>		H=53.8; d=20.8
<b>960 Mk II Estate (965)</b>				<b>08/1994 → 12/1996</b>	
Dust Cover Kit, shock absorber	2.5	ch.→R018099	<b>AK-735012</b>		
Control Arm-/Trailing Arm Bush	All Models		<b>F8-5106</b>		H=27; d=18; D=51
Control Arm-/Trailing Arm Bush	2.5		<b>F8-5140</b>		d=14; L=67.5; D=47
Control Arm-/Trailing Arm Bush	2.5	01/1995 →	<b>F8-5242</b>		H=65; d=12; D1=21; D2=40
Control Arm-/Trailing Arm Bush	2.9		<b>F8-5242</b>		H=65; d=12; D1=21; D2=40
Control Arm-/Trailing Arm Bush	All Models		<b>F8-5245</b>		
Control Arm-/Trailing Arm Bush	2.5		<b>F8-5254</b>		H=27; d=17; D=52



Article Description



Article Nr.

Fitting Position



### 960 Mk II Estate (965)

08/1994 → 12/1996

Mounting, stabilizer coupling rod	2.5		F8-5571		H=22.5; d=10; D=32.5
Suspension, panhard rod	2.5		F8-5735		H=40; d=20; D=40.5
Suspension, panhard rod	All Models		F8-5736		H=50; d=12; D=40
Rubber Buffer, suspension	2.5		F8-5899		D=25; H=95
Top Strut Mounting	2.5		F8-5983		d=18
Top Strut Mounting	2.5		F8-5984		d=18
Anti-Friction Bearing	2.5		F8-6267		H=12; W=91
Mounting, automatic transmission	2.5		F8-6549		
Bearing Bush, stabiliser	All Models		F8-6769		H=53.8; d=20.8

### C30

10/2006 → 12/2012

Dust Cover Kit, shock absorber	1.6, 1.6 D, 1.8, 2.0, 2.0 D, 2.4 i, D5, T5		AK-735305		
Dust Cover Kit, shock absorber	1.6, 1.6 D, 1.8, 2.0, 2.0 D, 2.4 i, D5, T5		AK-735306		
Alternator Freewheel Clutch	1.6 D, 2.0 D	Alternator Charge Current [A]: 120; Manufacturer Restriction: Denso	F5-1072		
Top Strut Mounting	1.6, 1.6 D, 1.8, 1.8 FlexFuel, 2.0, 2.0 D, 2.4 i, D5, T5		F8-6210		
Anti-Friction Bearing	1.6, 1.6 D, 1.8, 1.8 FlexFuel, 2.0, 2.0 D, 2.4 i, D5, T5		F8-6268		
Mounting, axle beam	1.6, 1.6 D, 1.8, 1.8 FlexFuel, 2.0, 2.0 D, 2.0 FlexFuel, 2.4 i, D5, T5		F8-6638		D=60
Belt Pulley, crankshaft	1.6 D	Number of Ribs: 6	F8-7082		Belt Pulley Ø [mm]=152; Mounting points diam.[mm]=30; W=34
Top Strut Mounting	1.6, 1.6 D, 1.8, 1.8 FlexFuel, 2.0, 2.0 D, 2.4 i, D5, T5		F8-7156		
Protective Cap/Bellow, shock absorber	All Models		F8-7838		H=250
Control Arm-/Trailing Arm Bush	1.6, 1.6 D, 1.8, 1.8 FlexFuel, 2.0, 2.0 D, 2.0 FlexFuel, 2.4 i, D5, T5		F8-8078		
Engine Mounting	1.6, 1.6 D, 1.8, 1.8 FlexFuel, 2.0, 2.0 D, 2.0 FlexFuel, 2.4 i, D5, T5		F8-8140		

### C70 I Convertible

03/1998 → 10/2005

Dust Cover Kit, shock absorber	All Models		AK-735003		
Dust Cover Kit, shock absorber	All Models		AK-735310		
Alternator Freewheel Clutch	2.0, 2.0 T, 2.3 T-5, 2.5 T	Alternator Charge Current [A]: 120; Manufacturer Restriction: Bosch	F5-1032		
Mounting, automatic transmission	2.0, 2.0 T, 2.3 T-5, 2.5, 2.5 T		F8-5027		H=59; d=12.2; D=60.5
Control Arm-/Trailing Arm Bush	2.0, 2.0 T, 2.3 T-5, 2.4 T, 2.5, 2.5 T		F8-5254		H=27; d=17; D=52
Top Strut Mounting	All Models		F8-5570		

<b>AK-735003</b>	<b>AK-735305</b>	<b>AK-735306</b>	<b>AK-735310</b>	<b>F5-1032</b>	<b>F5-1072</b>	<b>F8-5027</b>
Ref.Nr.:	Ref.Nr.: 30666842	Ref.Nr.: 30666243	Ref.Nr.: 3516327	Ref.Nr.: 9459747	Ref.Nr.: 30667067	Ref.Nr.: 9434263
<b>F8-5254</b>	<b>F8-5570</b>	<b>F8-5571</b>	<b>F8-5735</b>	<b>F8-5736</b>	<b>F8-5899</b>	<b>F8-5915</b>
Ref.Nr.: 6819057	Ref.Nr.: 9461728	Ref.Nr.: 1205991	Ref.Nr.: 1330427	Ref.Nr.: 1229715	Ref.Nr.: 1273849	Ref.Nr.: 31200599
<b>F8-5983</b>	<b>F8-5984</b>	<b>F8-6210</b>	<b>F8-6267</b>	<b>F8-6268</b>	<b>F8-6549</b>	<b>F8-6638</b>
Ref.Nr.: 1387188	Ref.Nr.: 1273747	Ref.Nr.: 3M513K155DC	Ref.Nr.: 1273747	Ref.Nr.: 30639948	Ref.Nr.: 1328900	Ref.Nr.: C2Y6-28-460

**Article Description****Article Nr.****Fitting Position****C70 I Convertible**

03/1998 → 10/2005

Top Strut Mounting	2.0, 2.0 T, 2.3 T-5, 2.5, 2.5 T		<b>F8-5915</b>		
Rubber Buffer, suspension	2.0, 2.0 T, 2.3 T5, 2.3 T-5, 2.5, 2.5 T		<b>F8-5919</b>		D=20; H=51
Rubber Buffer, suspension	2.0, 2.0 T, 2.3 T-5, 2.5		<b>F8-5920</b>		D=20; H=40
Rubber Buffer, suspension	2.0, 2.0 T, 2.3 T-5, 2.5		<b>F8-5921</b>		D=17; H=95
Rubber Buffer, suspension	2.0, 2.0 T, 2.3 T-5, 2.5		<b>F8-5922</b>		D=32; H=160
Top Strut Mounting	All Models		<b>F8-5929</b>		H=32; d=13,5
Repair Kit, suspension strut	All Models		<b>F8-6385</b>		
Mounting, axle beam	All Models		<b>F8-6759</b>		
Control Arm-/Trailing Arm Bush	All Models		<b>F8-7694</b>		
Control Arm-/Trailing Arm Bush	All Models	Aluminium	<b>F8-7695</b>		
Suspension Kit	All Models	Aluminium; with fastening material	<b>F8-7695S</b>		
Control Arm-/Trailing Arm Bush	All Models	Aluminium	<b>F8-7696</b>		
Suspension Kit	All Models	Aluminium; with fastening material	<b>F8-7696S</b>		
Engine Mounting	All Models		<b>F8-8148</b>		

**C70 I Coupe**

03/1997 → 09/2002

Dust Cover Kit, shock absorber	All Models		<b>AK-735003</b>		
Dust Cover Kit, shock absorber	All Models		<b>AK-735310</b>		
Alternator Freewheel Clutch	2.0, 2.0 T, 2.5 T		<b>F5-1015</b>		
Alternator Freewheel Clutch	2.0, 2.0 T, 2.5 T	Alternator Charge Current [A]: 120; Manufacturer Restriction: Bosch	<b>F5-1032</b>		
Mounting, automatic transmission	2.0, 2.0 T, 2.3 T-5, 2.5, 2.5 T		<b>F8-5027</b>		H=59; d=12.2; D=60.5
Mounting, automatic transmission	2.0, 2.0 T, 2.3 T-5, 2.5, 2.5 T		<b>F8-5027</b>		H=59; d=12.2; D=60.5
Control Arm-/Trailing Arm Bush	2.0, 2.0 T, 2.3 T-5, 2.5, 2.5 T		<b>F8-5254</b>		H=27; d=17; D=52
Control Arm-/Trailing Arm Bush	2.5	B 5254 S	<b>F8-5254</b>		H=27; d=17; D=52
Top Strut Mounting	All Models		<b>F8-5570</b>		
Top Strut Mounting	All Models		<b>F8-5915</b>		
Rubber Buffer, suspension	All Models		<b>F8-5919</b>		D=20; H=51
Rubber Buffer, suspension	2.0, 2.0 T, 2.3 T-5, 2.5		<b>F8-5920</b>		D=20; H=40
Rubber Buffer, suspension	2.0, 2.0 T, 2.3 T-5, 2.5		<b>F8-5921</b>		D=17; H=95
Rubber Buffer, suspension	2.0, 2.0 T, 2.3 T-5, 2.5		<b>F8-5922</b>		D=32; H=160
Top Strut Mounting	All Models		<b>F8-5929</b>		H=32; d=13,5

<b>AK-735003</b>	<b>AK-735310</b>	<b>F5-1015</b>	<b>F5-1032</b>	<b>F8-5027</b>	<b>F8-5254</b>	<b>F8-5570</b>
Ref.Nr.:	Ref.Nr.: 3516327	Ref.Nr.: 9404328	Ref.Nr.: 9459747	Ref.Nr.: 9434263	Ref.Nr.: 6819057	Ref.Nr.: 9461728
<b>F8-5915</b>	<b>F8-5919</b>	<b>F8-5920</b>	<b>F8-5921</b>	<b>F8-5922</b>	<b>F8-5929</b>	<b>F8-6385</b>
Ref.Nr.: 31200599	Ref.Nr.: 9140067	Ref.Nr.: 9140129	Ref.Nr.: 3516327	Ref.Nr.: 3546705	Ref.Nr.: 3516151	Ref.Nr.: 9173203
<b>F8-6759</b>	<b>F8-7694</b>	<b>F8-7695</b>	<b>F8-7695S</b>	<b>F8-7696</b>	<b>F8-7696S</b>	<b>F8-8148</b>
Ref.Nr.: 3507924	Ref.Nr.: 3530050	Ref.Nr.: 3530202	Ref.Nr.: 3530202	Ref.Nr.: 3516496	Ref.Nr.: 3516496	Ref.Nr.: 8659000

Article Description			Article Nr.	Fitting Position	
---------------------	--	--	-------------	------------------	--

<b>C70 I Coupe</b>			03/1997 → 09/2002		
Repair Kit, suspension strut	All Models		F8-6385		
Mounting, axle beam	All Models		F8-6759		
Control Arm-/Trailing Arm Bush	All Models		F8-7694		
Control Arm-/Trailing Arm Bush	All Models	Aluminium	F8-7695		
Suspension Kit	All Models	Aluminium; with fastening material	F8-7695S		
Control Arm-/Trailing Arm Bush	All Models	Aluminium	F8-7696		
Suspension Kit	All Models	Aluminium; with fastening material	F8-7696S		
Engine Mounting	All Models		F8-8148		

<b>C70 II Convertible</b>			03/2006 → 06/2013		
Dust Cover Kit, shock absorber	2.4, 2.4 i, D5, T5		AK-735305		
Alternator Freewheel Clutch	2.0 D	Alternator Charge Current [A]: 120; Manufacturer Restriction: Denso	F5-1072		
Alternator Freewheel Clutch	2.4, 2.4 i, D5, T5	Alternator Nr: 104210-3550, 104210-3560, 104210-4640; Manufacturer Restriction: Denso	F5-1151		
Top Strut Mounting	2.0 D, 2.4, 2.4 i, D5, T5		F8-6210		
Anti-Friction Bearing	2.0 D, 2.4, 2.4 i, D5, T5		F8-6268		
Mounting, axle beam	2.0 D, 2.4, 2.4 i, D5, T5		F8-6638		D=60
Top Strut Mounting	2.0 D, 2.4, 2.4 i, D5, T5		F8-7156		
Protective Cap/Bellow, shock absorber	All Models		F8-7838		H=250
Control Arm-/Trailing Arm Bush	2.0 D, 2.4, 2.4 i, T5		F8-8078		
Control Arm-/Trailing Arm Bush	D5	D 5244 T8	F8-8078		
Engine Mounting	2.0 D, 2.4, 2.4 i, D5, T5		F8-8140		

<b>S40 I (VS)</b>			07/1995 → 12/2003		
Dust Cover Kit, shock absorber	1.6, 1.8, 1.8 i, 1.9 DI, 1.9 T4, 1.9 TD, 2.0, 2.0 T		AK-735024		
Dust Cover Kit, shock absorber	1.6, 1.8, 1.8 i, 1.9 DI, 1.9 TD, 2.0, 2.0 T		AK-735121		
Dust Cover Kit, shock absorber	1.8 i, 1.9 DI, 2.0 T, 2.0 T4		AK-735123		
Alternator Freewheel Clutch	1.9 DI, 1.9 TD		F5-1014		
Alternator Freewheel Clutch	1.9 DI, 1.9 TD		F5-1025		
Alternator Freewheel Clutch	1.6, 1.8, 1.8 i, 1.9 T4, 2.0, 2.0 T, 2.0 T4		F5-1087		
Control Arm-/Trailing Arm Bush	1.6, 1.8, 1.8 i, 1.9 DI, 1.9 T4, 1.9 TD, 2.0, 2.0 T, 2.0 T4		F8-5249		H=60; d=12; D=37
Top Strut Mounting	1.6, 1.8, 1.8 i, 1.9 DI, 1.9 T4, 1.9 TD, 2.0, 2.0 T		F8-5933		

<b>AK-735024</b>	<b>AK-735121</b>	<b>AK-735123</b>	<b>AK-735305</b>	<b>F5-1014</b>	<b>F5-1025</b>	<b>F5-1072</b>
Ref.Nr.:	Ref.Nr.:	Ref.Nr.: 30884200	Ref.Nr.: 30666842	Ref.Nr.: 8641982	Ref.Nr.: 23151-00Q0B	Ref.Nr.: 30667067
<b>F5-1087</b>	<b>F5-1151</b>	<b>F8-5249</b>	<b>F8-5933</b>	<b>F8-6210</b>	<b>F8-6262</b>	<b>F8-6268</b>
Ref.Nr.: 30782701	Ref.Nr.:	Ref.Nr.: 30818467	Ref.Nr.: 30818465	Ref.Nr.: 3M513K155DC	Ref.Nr.: 97BG-3K099-AA	Ref.Nr.: 30639948
<b>F8-6385</b>	<b>F8-6638</b>	<b>F8-6759</b>	<b>F8-7156</b>	<b>F8-7694</b>	<b>F8-7695</b>	<b>F8-7695S</b>
Ref.Nr.: 9173203	Ref.Nr.: C2Y6-28-460	Ref.Nr.: 3507924	Ref.Nr.: BP4L-34-380C	Ref.Nr.: 3530050	Ref.Nr.: 3530202	Ref.Nr.: 3530202

**Article Description****Article Nr.****Fitting Position**

<b>S40 I (VS)</b>			<b>07/1995 → 12/2003</b>		
Anti-Friction Bearing	1.6, 1.8, 1.8 i, 1.9 DI, 2.0, 2.0 T4	06/2001 →;	<b>F8-6262</b>		
Anti-Friction Bearing	1.8 i, 2.0 T		<b>F8-6262</b>		
Anti-Friction Bearing	1.9 DI	06/2001 →;	<b>F8-6262</b>		
Top Strut Mounting	1.6, 1.8, 1.8 i, 1.9 DI, 1.9 T4, 2.0, 2.0 T	01/2000 →;	<b>F8-6337</b>		
Top Strut Mounting	1.8 i, 1.9 DI, 2.0 T, 2.0 T4		<b>F8-6337</b>		
Rod/Strut, wheel suspension	All Models		<b>F8-6469</b>		L=143
Control Arm-/Trailing Arm Bush	All Models		<b>F8-6696</b>		
Control Arm-/Trailing Arm Bush	1.6, 1.8, 1.8 i, 1.9 DI, 1.9 T4, 1.9 TD, 2.0, 2.0 T, 2.0 T4		<b>F8-6772</b>		H=49.5; d=12.2; D1=36.2; D2=34.7
Engine Mounting	1.9 DI, 1.9 TD, 2.0, 2.0 T		<b>F8-6994</b>		
Engine Mounting	1.9 T4	B 4194 T	<b>F8-6994</b>		
Bellow, steering	1.6, 1.8 i, 1.9 DI, 1.9 T4, 1.9 TD, 2.0, 2.0 T, 2.0 T4	with clamps	<b>LM-10061S</b>		d1=11; d2=41; L [mm]=200
Bellow Set, drive shaft	1.9 T4, 2.0, 2.0 T, 2.0 T4	with clamps;	<b>MK-810160</b>		L=116
<b>S40 II (MS)</b>			<b>01/2004 →</b>		
Dust Cover Kit, shock absorber	1.6, 1.6 D, 1.8, 1.8 FlexFuel, 2.0, 2.0 D, 2.0 D4, 2.4, 2.4 AWD, 2.4 D5, T5, T5 AWD		<b>AK-735305</b>		
Dust Cover Kit, shock absorber	1.6, 1.6 D, 1.8, 1.8 FlexFuel, 2.0, 2.0 D, 2.0 D4, 2.4, 2.4 AWD, 2.4 D5, T5, T5 AWD		<b>AK-735306</b>		
Alternator Freewheel Clutch	1.6 D, 2.0 D, 2.0 D4	Alternator Charge Current [A]: 120; Manufacturer Restriction: Denso	<b>F5-1072</b>		
Alternator Freewheel Clutch	2.4, 2.4 AWD, 2.4 D5, T5, T5 AWD	Alternator Nr: 104210-3550, 104210-3560, 104210-4640; Manufacturer Restriction: Denso	<b>F5-1151</b>		
Top Strut Mounting	All Models		<b>F8-6210</b>		
Anti-Friction Bearing	1.6, 1.6 D, 1.8, 1.8 FlexFuel, 2.0, 2.0 D, 2.0 D4, 2.4, 2.4 AWD, 2.4 D5, T5, T5 AWD		<b>F8-6268</b>		
Top Strut Mounting	All Models		<b>F8-6357</b>		
Mounting, axle beam	1.6, 1.6 D, 1.8, 1.8 FlexFuel, 2.0, 2.0 D, 2.0 D4, 2.4, 2.4 AWD, 2.4 D5, T5, T5 AWD		<b>F8-6638</b>		D=60
Belt Pulley, crankshaft	1.6 D	Number of Ribs: 6	<b>F8-7082</b>		Belt Pulley Ø [mm]=152; Mounting points diam.[mm]=30; W=34
Top Strut Mounting	1.6, 1.6 D, 1.8, 1.8 FlexFuel, 2.0, 2.0 D, 2.0 D4, 2.4, 2.4 AWD, 2.4 D5, T5, T5 AWD		<b>F8-7156</b>		
Protective Cap/Bellow, shock absorber	All Models		<b>F8-7838</b>		H=250
Control Arm-/Trailing Arm Bush	1.6, 1.6 D, 1.8, 1.8 FlexFuel, 2.0, 2.0 D, 2.0 D4, 2.4, 2.4 AWD, T5, T5 AWD		<b>F8-8078</b>		
Control Arm-/Trailing Arm Bush	2.4 D5	D 5244 T8	<b>F8-8078</b>		

<b>AK-735305</b>	<b>AK-735306</b>	<b>F5-1072</b>	<b>F5-1151</b>	<b>F8-6210</b>	<b>F8-6262</b>	<b>F8-6268</b>
Ref.Nr.: 30666842	Ref.Nr.: 30666243	Ref.Nr.: 30667067	Ref.Nr.:	Ref.Nr.: 3M513K155DC	Ref.Nr.: 97BG-3K099-AA	Ref.Nr.: 30639948
<b>F8-6337</b>	<b>F8-6357</b>	<b>F8-6469</b>	<b>F8-6638</b>	<b>F8-6696</b>	<b>F8-6772</b>	<b>F8-6994</b>
Ref.Nr.: 30616824	Ref.Nr.: 30714395	Ref.Nr.: 30620785	Ref.Nr.: C2Y6-28-460	Ref.Nr.: MR102063	Ref.Nr.: 30620972	Ref.Nr.: 30611144
<b>F8-7082</b>	<b>F8-7156</b>	<b>F8-7838</b>	<b>F8-8078</b>	<b>F8-8140</b>	<b>LM-10061S</b>	<b>MK-810160</b>
Ref.Nr.: 0515.R0	Ref.Nr.: BP4L-34-380C	Ref.Nr.: 1305329	Ref.Nr.: 3M5J-3A262-BP	Ref.Nr.: 30778647	Ref.Nr.: 3345796	Ref.Nr.: 3D0 498 201

<b>Article Description</b>			<b>Article Nr.</b>	<b>Fitting Position</b>	
----------------------------	--	--	--------------------	-------------------------	--

<b>S40 II (MS)</b>		<b>01/2004 →</b>			
Engine Mounting	1,6, 1,6 D, 1,8, 1,8 FlexFuel, 2,0, 2,0 D, 2,0 D4, 2,4, 2,4 AWD, 2,4 D5, T5, T5 AWD		<b>F8-8140</b>		
<b>S60 I</b>		<b>07/2000 → 04/2010</b>			
Dust Cover Kit, shock absorber	2,0 T, 2,4, 2,4 Bifuel, 2,4 D, 2,4 D5, 2,4 T, 2,4 T AWD, 2,4 T5, 2,5 T, 2,5 T AWD, T5		<b>AK-735130</b>		⊕ ⊕
Dust Cover Kit, shock absorber	2,0 T, 2,3 T5, 2,4, 2,4 AWD, 2,4 Bifuel, 2,4 D, 2,4 D5, 2,4 T, 2,4 T AWD, 2,4 T5, 2,5 T, 2,5 T AWD, T5		<b>AK-735307</b>		⊕ ⊕
Dust Cover Kit, shock absorber	R 2,5 T AWD		<b>AK-735308</b>		⊕ ⊕
Dust Cover Kit, shock absorber	R 2,5 T AWD		<b>AK-735309</b>		⊕ ⊕
Alternator Freewheel Clutch	2,4 D, 2,4 D5, 2,5 T, 2,5 T AWD, R 2,5 T AWD		<b>F5-1031</b>		
Alternator Freewheel Clutch	2,0 T, 2,4, 2,4 Bifuel, 2,4 T, 2,4 T AWD, 2,5 T, 2,5 T AWD, T5	Alternator Charge Current [A]: 140	<b>F5-1032</b>		
Top Strut Mounting	2,0 T, 2,3 T5, 2,4, 2,4 AWD, 2,4 Bifuel, 2,4 D, 2,4 D5, 2,4 T, 2,4 T AWD, 2,4 T5, 2,5 T, 2,5 T AWD, R 2,5 T AWD, T5		<b>F8-5570</b>		⊕ ⊕ ⊕ ↓
Top Strut Mounting	2,0 T, 2,3 T5, 2,4, 2,4 AWD, 2,4 Bifuel, 2,4 D, 2,4 D5, 2,4 T, 2,4 T AWD, 2,4 T5, 2,5 T, 2,5 T AWD, R 2,5 T AWD, T5		<b>F8-6014</b>		⊕ ⊕ ⊕ ↑
Control Arm-/Trailing Arm Bush	2,0 T, 2,3 T5, 2,4, 2,4 Bifuel, 2,4 D, 2,4 D5, 2,4 T, 2,4 T AWD, 2,5 T, 2,5 T AWD, R 2,5 T AWD, T5		<b>F8-6166</b>		↓ L=123; D=48
Control Arm-/Trailing Arm Bush	2,0 T, 2,3 T5, 2,4, 2,4 Bifuel, 2,4 D, 2,4 D5, 2,4 T, 2,5 T, 2,5 T AWD, R 2,5 T AWD, T5		<b>F8-6167</b>		⊕ ⊕ ⊕ ↓ H1=29, 50; d=14; D=53
Top Strut Mounting	2,0 T, 2,3 T5, 2,4, 2,4 Bifuel, 2,4 D, 2,4 D5, 2,4 T, 2,4 T AWD, 2,5 T, T5		<b>F8-6198</b>		⊕ ⊕
Repair Kit, suspension strut	2,0 T, 2,4, 2,4 Bifuel, 2,4 D, 2,4 D5, 2,4 T, 2,4 T AWD, 2,4 T5, 2,5 T, 2,5 T AWD, R 2,5 T AWD, T5		<b>F8-6384</b>		⊕ ⊕
Mounting, axle beam	2,0 T, 2,3 T5, 2,4, 2,4 Bifuel, 2,4 D, 2,4 D5, 2,4 T, 2,4 T AWD, 2,4 T5, 2,5 T, 2,5 T AWD, R 2,5 T AWD, T5		<b>F8-6759</b>		⊕
Engine Mounting	2,4 D, 2,4 D5		<b>F8-6992</b>		
Engine Mounting	2,4 D, 2,4 D5		<b>F8-6993</b>		
Rubber Buffer, suspension	2,0 T, 2,3 T5, 2,4, 2,4 AWD, 2,4 Bifuel, 2,4 D, 2,4 D5, 2,4 T, 2,4 T AWD, 2,4 T5, 2,5 T, 2,5 T AWD, R 2,5 T AWD, T5	<b>ST</b>	<b>F8-7680</b>		⊕ ⊕ H=68
Engine Mounting	2,0 T, 2,3 T5, 2,4, 2,4 Bifuel, 2,4 T, 2,5 T, T5		<b>F8-8148</b>		
Engine Mounting	2,0 T, 2,4, 2,4 Bifuel, 2,4 D, 2,4 D5, 2,4 T, 2,4 T AWD, 2,4 T5, 2,5 T, 2,5 T AWD, R 2,5 T AWD, T5		<b>F8-8156</b>		⊕
Bellow Set, drive shaft	2,0 T, 2,4 T AWD, 2,4 T5, T5	with clamps;	<b>MK-810160</b>		L=116
<b>S60 II</b>		<b>04/2010 → 04/2012</b>			
Alternator Freewheel Clutch	2,0 T, T5		<b>F5-1134</b>		
Top Strut Mounting	2,0 T, D3, D5, D5 AWD, DRIVE / D2, T3, T4, T4F, T5, T6 AWD		<b>F8-7606</b>		⊕ ⊕

<b>AK-735130</b>	<b>AK-735307</b>	<b>AK-735308</b>	<b>AK-735309</b>	<b>F5-1031</b>	<b>F5-1032</b>	<b>F5-1134</b>
Ref.Nr.: 8672087	Ref.Nr.: 9157115	Ref.Nr.: 30666850	Ref.Nr.: 8646295	Ref.Nr.: 021903119H	Ref.Nr.: 9459747	Ref.Nr.: 31285489
<b>F8-5570</b>	<b>F8-6014</b>	<b>F8-6166</b>	<b>F8-6167</b>	<b>F8-6198</b>	<b>F8-6384</b>	<b>F8-6759</b>
Ref.Nr.: 9461728	Ref.Nr.: 30714968	Ref.Nr.: 9173618	Ref.Nr.: 8630604	Ref.Nr.: 9157745	Ref.Nr.: 30714968	Ref.Nr.: 3507924
<b>F8-6992</b>	<b>F8-6993</b>	<b>F8-7606</b>	<b>F8-7607</b>	<b>F8-7680</b>	<b>F8-8140</b>	<b>F8-8148</b>
Ref.Nr.: 8624755	Ref.Nr.: 30645447	Ref.Nr.: 1734710	Ref.Nr.: 1510474	Ref.Nr.: 9157115	Ref.Nr.: 30778647	Ref.Nr.: 8659000



**Article Description****Article Nr.****Fitting Position**

<b>S60 II</b>		<b>04/2010 → 04/2012</b>	
Anti-Friction Bearing	2.0 T, D3, D5, D5 AWD, DRIVE / D2, T3, T4, T4F, T5, T6 AWD	<b>F8-7607</b>	
Top Strut Mounting	2.0 T, D3, D5, D5 AWD, DRIVE / D2, T3, T4, T4F, T5, T6 AWD	<b>F8-7608</b>	
Protective Cap/Bellow, shock absorber	2.0 T, D3, D4, D5, D5 AWD, DRIVE / D2, T3, T4, T4F, T5, T6, T6 AWD	<b>F8-7838</b>	H=250
Control Arm-/Trailing Arm Bush	D5 AWD, T6 AWD	<b>F8-7877</b>	
Control Arm-/Trailing Arm Bush	2.0 T, D3, D5, D5 AWD, DRIVE / D2, T3, T4, T4F, T5, T6 AWD	<b>F8-7878</b>	
Control Arm-/Trailing Arm Bush	2.0 T, D3, D4, D5, D5 AWD, DRIVE / D2, T3, T4, T4F, T5, T6	<b>F8-8069</b>	
Control Arm-/Trailing Arm Bush	2.0 T, 3.0 T AWD, D3, D4, D5, D5 AWD, DRIVE / D2, T3, T4, T4F, T5, T6, T6 AWD	<b>F8-8074</b>	
Control Arm-/Trailing Arm Bush	2.0 T, 3.0 T AWD, D3, D4, D5, D5 AWD, DRIVE / D2, T3, T4, T4F, T5, T6, T6 AWD	<b>F8-8075</b>	
<b>S70 (LS)</b>		<b>11/1996 → 11/2000</b>	
Dust Cover Kit, shock absorber	2.0, 2.0 Turbo, 2.3 AWD, 2.3 T-5, 2.3 T5 AWD, 2.3 T5 R AWD, 2.3 Turbo, 2.4, 2.4 T5 AWD, 2.4 Turbo, 2.5, 2.5 Bifuel, 2.5 TDI	<b>AK-735003</b>	
Dust Cover Kit, shock absorber	2.0, 2.0 Turbo, 2.3 AWD, 2.3 Turbo, 2.4, 2.4 Turbo, 2.5, 2.5 Bifuel, 2.5 TDI	<b>AK-735310</b>	
Rubber Buffer, suspension	2.3 T-5, 2.3 T5 AWD, 2.3 T5 R AWD, 2.4 T5 AWD	<b>AK-735311</b>	
Alternator Freewheel Clutch	2.0, 2.0 Turbo, 2.3, 2.3 AWD, 2.3 T-5, 2.3 T5 AWD, 2.3 T5 R AWD, 2.3 Turbo, 2.4, 2.4 AWD, 2.4 T5 AWD, 2.4 Turbo, 2.5 Bifuel	<b>F5-1015</b>	
Alternator Freewheel Clutch	2.5 TDI, 2.5 TDI AWD	<b>F5-1031</b>	
Alternator Freewheel Clutch	2.0, 2.0 Turbo, 2.3 T-5, 2.3 Turbo, 2.4, 2.4 Turbo, 2.5, 2.5 Bifuel	<b>F5-1032</b>	Alternator Charge Current [A]: 120; Manufacturer Restriction: Bosch
Mounting, automatic transmission	2.0, 2.0 Turbo, 2.3 T-5, 2.3 Turbo, 2.4, 2.4 Turbo, 2.5, 2.5 Bifuel, 2.5 TDI	<b>F8-5027</b>	H=59; d=12.2; D=60.5
Control Arm-/Trailing Arm Bush	2.0, 2.0 Turbo, 2.3, 2.3 T-5, 2.4 Turbo, 2.5, 2.5 Bifuel, 2.5 TDI	<b>F8-5254</b>	H=27; d=17; D=52
Control Arm-/Trailing Arm Bush	2.4	B 5244 S	<b>F8-5254</b> H=27; d=17; D=52
Control Arm-/Trailing Arm Bush	2.4	B 5244 S2	<b>F8-5254</b> H=27; d=17; D=52
Control Arm-/Trailing Arm Bush	2.4	B 5254 S	<b>F8-5254</b> H=27; d=17; D=52
Top Strut Mounting	2.0, 2.0 Turbo, 2.3, 2.3 AWD, 2.3 T-5, 2.3 T5 AWD, 2.3 T5 R AWD, 2.3 Turbo, 2.4, 2.4 AWD, 2.4 Blu-Fuel, 2.4 T5 AWD, 2.4 Turbo, 2.5, 2.5 Bifuel, 2.5 TDI, 2.5 TDI AWD	<b>F8-5570</b>	

<b>AK-735003</b>	<b>AK-735310</b>	<b>AK-735311</b>	<b>F5-1015</b>	<b>F5-1031</b>	<b>F5-1032</b>	<b>F8-5027</b>
Ref.Nr.:	Ref.Nr.: 3516327	Ref.Nr.: 9140177	Ref.Nr.: 9404328	Ref.Nr.: 021903119H	Ref.Nr.: 9459747	Ref.Nr.: 9434263
<b>F8-5254</b>	<b>F8-5570</b>	<b>F8-5915</b>	<b>F8-7607</b>	<b>F8-7608</b>	<b>F8-7838</b>	<b>F8-7877</b>
Ref.Nr.: 6819057	Ref.Nr.: 9461728	Ref.Nr.: 31200599	Ref.Nr.: 1510474	Ref.Nr.: 6G91-3K099-NB	Ref.Nr.: 1305329	Ref.Nr.: 1865033
<b>F8-7878</b>	<b>F8-8069</b>	<b>F8-8074</b>	<b>F8-8075</b>			
Ref.Nr.: 31 277 755	Ref.Nr.: 31387282	Ref.Nr.: 7G9J-3A262-AB	Ref.Nr.: 1507181			

Article Description



Article Nr.

Fitting Position



<b>S70 (LS)</b>		<b>11/1996 → 11/2000</b>	
Top Strut Mounting	2.0, 2.0 Turbo, 2.3, 2.3 AWD, 2.3 T-5, 2.3 T5 AWD, 2.3 Turbo, 2.4, 2.4 AWD, 2.4 Blu-Fuel, 2.4 T5 AWD, 2.4 Turbo, 2.5, 2.5 Bifuel, 2.5 TDI, 2.5 TDi AWD		F8-5915
Rubber Buffer, suspension	2.0, 2.0 Turbo, 2.3, 2.3 T-5, 2.3 Turbo, 2.4, 2.4 Turbo, 2.5, 2.5 Bifuel, 2.5 TDI		F8-5919  D=20; H=51
Rubber Buffer, suspension	2.0, 2.0 Turbo, 2.3, 2.3 T-5, 2.4, 2.4 Turbo, 2.5, 2.5 TDI		F8-5920  D=20; H=40
Rubber Buffer, suspension	2.0, 2.0 Turbo, 2.3 AWD, 2.3 T-5, 2.4, 2.4 Turbo, 2.5, 2.5 TDI		F8-5921  D=17; H=95
Rubber Buffer, suspension	2.0, 2.0 Turbo, 2.3 AWD, 2.3 T-5, 2.4, 2.4 Turbo, 2.5, 2.5 TDI		F8-5922  D=32; H=160
Top Strut Mounting	2.0, 2.0 Turbo, 2.3, 2.3 T-5, 2.3 T5 AWD, 2.3 T5 R AWD, 2.3 Turbo, 2.4, 2.4 T5 AWD, 2.4 Turbo, 2.5, 2.5 Bifuel, 2.5 TDI		F8-5929  H=32; d=13,5
Top Strut Mounting	2.4 Blu-Fuel		F8-5929  H=32; d=13,5
Repair Kit, suspension strut	2.0, 2.0 Turbo, 2.3 T-5, 2.3 Turbo, 2.4, 2.4 Turbo, 2.5, 2.5 Bifuel, 2.5 TDI		F8-6385
Control Arm-/Trailing Arm Bush	2.0, 2.0 Turbo, 2.3 T-5, 2.3 Turbo, 2.4, 2.4 Turbo, 2.5, 2.5 Bifuel, 2.5 TDI		F8-6548
Mounting, axle beam	2.0, 2.0 Turbo, 2.3, 2.3 T-5, 2.3 Turbo, 2.4, 2.4 AWD, 2.4 Blu-Fuel, 2.4 T5 AWD, 2.4 Turbo, 2.5, 2.5 Bifuel, 2.5 TDI, 2.5 TDi AWD		F8-6759
Control Arm-/Trailing Arm Bush	2.0, 2.0 Turbo, 2.3, 2.3 T-5, 2.3 Turbo, 2.4, 2.4 Blu-Fuel, 2.4 Turbo, 2.5, 2.5 Bifuel, 2.5 TDI		F8-7694
Control Arm-/Trailing Arm Bush	2.0, 2.0 Turbo, 2.3, 2.3 T-5, 2.3 Turbo, 2.4, 2.4 Blu-Fuel, 2.4 Turbo, 2.5, 2.5 Bifuel, 2.5 TDI	Aluminium	F8-7695
Suspension Kit	2.0, 2.0 Turbo, 2.3, 2.3 T-5, 2.3 Turbo, 2.4, 2.4 Blu-Fuel, 2.4 Turbo, 2.5, 2.5 Bifuel, 2.5 TDI	Aluminium; with fastening material	F8-7695S
Control Arm-/Trailing Arm Bush	2.0, 2.0 Turbo, 2.3, 2.3 T-5, 2.3 Turbo, 2.4, 2.4 Blu-Fuel, 2.4 Turbo, 2.5, 2.5 Bifuel, 2.5 TDI	Aluminium	F8-7696
Suspension Kit	2.0, 2.0 Turbo, 2.3, 2.3 T-5, 2.3 Turbo, 2.4, 2.4 Blu-Fuel, 2.4 Turbo, 2.5, 2.5 Bifuel, 2.5 TDI	Aluminium; with fastening material	F8-7696S
Engine Mounting	2.0, 2.0 Turbo, 2.3, 2.3 T-5, 2.4, 2.4 Turbo, 2.5, 2.5 Bifuel		F8-8148
Engine Mounting	2.0, 2.0 Turbo, 2.3 T-5, 2.3 Turbo, 2.4, 2.4 Turbo, 2.5, 2.5 Bifuel		F8-8190
<b>S80 I (TS, XY)</b>		<b>05/1998 → 07/2006</b>	
Dust Cover Kit, shock absorber	2.0, 2.0 T, 2.4, 2.4 Bifuel, 2.4 D, 2.4 D5, 2.4 T, 2.5 T AWD, 2.5 TDI, 2.8 T6, 2.9, 3.0, 3.0 T6		AK-735130
Dust Cover Kit, shock absorber	2.0, 2.0 T, 2.3 R, 2.4, 2.4 Bifuel, 2.4 D, 2.4 D5, 2.4 LTP, 2.4 T, 2.4 T5 AWD, 2.5 T, 2.5 T AWD, 2.5 TDI, 2.8 T6, 2.9, 3.0, 3.0 T6		AK-735307
Alternator Freewheel Clutch	2.4 D, 2.4 D5, 2.4 T, 2.4 T5 AWD, 2.5 TDI		F5-1031
Top Strut Mounting	2.0 T, 2.3 R, 2.4 Bifuel, 2.4 D5, 2.4 LTP, 2.4 T, 2.4 T5 AWD, 2.5 T, 2.5 T AWD, 3.0, 3.0 T6		F8-5570

<b>AK-735130</b>	<b>AK-735307</b>	<b>F5-1031</b>	<b>F8-5570</b>	<b>F8-5915</b>	<b>F8-5919</b>	<b>F8-5920</b>
Ref.Nr.: 8672087	Ref.Nr.: 9157115	Ref.Nr.: 021903119H	Ref.Nr.: 9461728	Ref.Nr.: 31200599	Ref.Nr.: 9140067	Ref.Nr.: 9140129
<b>F8-5921</b>	<b>F8-5922</b>	<b>F8-5929</b>	<b>F8-6385</b>	<b>F8-6548</b>	<b>F8-6759</b>	<b>F8-7694</b>
Ref.Nr.: 3516327	Ref.Nr.: 3546705	Ref.Nr.: 3516151	Ref.Nr.: 9173203	Ref.Nr.: 271631	Ref.Nr.: 3507924	Ref.Nr.: 3530050
<b>F8-7695</b>	<b>F8-7695S</b>	<b>F8-7696</b>	<b>F8-7696S</b>	<b>F8-8148</b>	<b>F8-8190</b>	
Ref.Nr.: 3530202	Ref.Nr.: 3530202	Ref.Nr.: 3516496	Ref.Nr.: 3516496	Ref.Nr.: 8659000	Ref.Nr.: 8631698	

**Article Description****Article Nr.****Fitting Position****S80 I (TS, XY) 05/1998 → 07/2006**

Top Strut Mounting	2.0, 2.0 T, 2.4, 2.5 TDI, 2.8 T6, 2.9	ch.153440→;	<b>F8-5570</b>		
Top Strut Mounting	2.0, 2.0 T, 2.4, 2.4 Bifuel, 2.4 D5, 2.4 LTP, 2.4 T, 2.4 T5 AWD, 2.5 T, 2.5 T AWD, 2.5 TDI, 2.8 T6, 2.9, 3.0, 3.0 T6	ch.→153439	<b>F8-5915</b>		
Top Strut Mounting	2.3 R		<b>F8-5915</b>		
Top Strut Mounting	2.0, 2.0 T, 2.3 R, 2.4, 2.4 Bifuel, 2.4 D, 2.4 D5, 2.4 LTP, 2.4 T, 2.4 T5 AWD, 2.5 T, 2.5 T AWD, 2.5 TDI, 2.8 T6, 2.9, 3.0, 3.0 T6	ch.153440→	<b>F8-6014</b>		
Control Arm-/Trailing Arm Bush	2.0, 2.0 T, 2.4, 2.4 Bifuel, 2.4 D, 2.4 D5, 2.4 T, 2.4 T5 AWD, 2.5 T, 2.5 T AWD, 2.5 TDI, 2.8 T6, 2.9, 3.0, 3.0 T6		<b>F8-6166</b>		L=123; D=48
Control Arm-/Trailing Arm Bush	2.0, 2.0 T, 2.4, 2.4 Bifuel, 2.4 D, 2.4 D5, 2.4 T5 AWD, 2.5 T, 2.5 T AWD, 2.5 TDI, 2.8 T6, 2.9, 3.0, 3.0 T6		<b>F8-6167</b>		H1=29, 50; d=14; D=53
Top Strut Mounting	2.0, 2.0 T, 2.4, 2.4 Bifuel, 2.4 D, 2.4 D5, 2.4 LTP, 2.4 T, 2.4 T5 AWD, 2.5 T, 2.5 TDI, 2.8 T6, 2.9, 3.0, 3.0 T6		<b>F8-6198</b>		
Repair Kit, suspension strut	2.0, 2.0 T, 2.4, 2.4 Bifuel, 2.4 D, 2.4 D5, 2.4 T, 2.5 T, 2.5 T AWD, 2.5 TDI, 2.8 T6, 2.9, 3.0, 3.0 T6	ch.153440→	<b>F8-6384</b>		
Repair Kit, suspension strut	2.0, 2.0 T, 2.4, 2.4 Bifuel, 2.4 D, 2.4 D5, 2.4 T, 2.5 T, 2.5 T AWD, 2.5 TDI, 2.8 T6, 2.9, 3.0, 3.0 T6	ch.→153439	<b>F8-6385</b>		
Mounting, axle beam	2.0, 2.0 T, 2.4, 2.4 Bifuel, 2.4 D, 2.4 D5, 2.4 T, 2.4 T5 AWD, 2.5 T, 2.5 T AWD, 2.5 TDI, 2.8 T6, 2.9, 3.0, 3.0 T6		<b>F8-6759</b>		
Engine Mounting	2.8 T6, 2.9, 3.0, 3.0 T6		<b>F8-6882</b>		
Engine Mounting	2.4 D, 2.4 D5, 2.5 TDI		<b>F8-6992</b>		
Engine Mounting	2.4 D, 2.4 D5		<b>F8-6993</b>		
Rubber Buffer, suspension	2.0, 2.0 T, 2.3 R, 2.4, 2.4 Bifuel, 2.4 D, 2.4 D5, 2.4 LTP, 2.4 T, 2.5 T, 2.5 T AWD, 2.5 TDI, 2.8 T6, 2.9, 3.0, 3.0 T6	<b>ST</b>	<b>F8-7680</b>		H=68
Engine Mounting	2.0, 2.0 T, 2.4, 2.4 Bifuel, 2.4 Bifuel (LPG), 2.5 T		<b>F8-8148</b>		
Engine Mounting	2.0, 2.0 T, 2.4, 2.4 Bifuel, 2.4 D, 2.4 D5, 2.4 T, 2.5 T, 2.5 T AWD, 3.0 T6		<b>F8-8156</b>		
Bellow Set, drive shaft	2.0 T	with clamps	<b>MK-810160</b>		L=116
Bellow Set, drive shaft	2.4 T, 2.5 T AWD, 2.9, 3.0 T6	with clamps;	<b>MK-810160</b>		L=116

**S80 II (AS) 03/2006 →**

Alternator Freewheel Clutch	2.4 D		<b>F5-1031</b>		
Alternator Freewheel Clutch	2.0 TDi		<b>F5-1046</b>		
Alternator Freewheel Clutch	2.0, 2.0 FlexFuel		<b>F5-1075</b>		
Alternator Freewheel Clutch	2.0 T, T5		<b>F5-1134</b>		
Anti-Friction Bearing	1.6 D DRIVE, 1.6 DRIVE, 2.0, 2.0 FlexFuel, 2.0 T, 2.0 TDi, 2.4 D, 2.5 T, 2.5 T AWD, 2.5 T FlexFuel, 3.2, 3.2 AWD, 4.4 V8 AWD, D5, D5 AWD, T4, T4F, T5, T6 AWD		<b>F8-7607</b>		

<b>F5-1031</b>	<b>F5-1046</b>	<b>F5-1075</b>	<b>F5-1134</b>	<b>F8-5570</b>	<b>F8-5915</b>	<b>F8-6014</b>
Ref.Nr.: 021903119H	Ref.Nr.: 30667687	Ref.Nr.: 30667610	Ref.Nr.: 31285489	Ref.Nr.: 9461728	Ref.Nr.: 31200599	Ref.Nr.: 30714968
<b>F8-6166</b>	<b>F8-6167</b>	<b>F8-6198</b>	<b>F8-6384</b>	<b>F8-6385</b>	<b>F8-6759</b>	<b>F8-6882</b>
Ref.Nr.: 9173618	Ref.Nr.: 8630604	Ref.Nr.: 9157745	Ref.Nr.: 30714968	Ref.Nr.: 9173203	Ref.Nr.: 3507924	Ref.Nr.: 8671633
<b>F8-6992</b>	<b>F8-6993</b>	<b>F8-7607</b>	<b>F8-7680</b>	<b>F8-7838</b>	<b>F8-8148</b>	<b>F8-8156</b>
Ref.Nr.: 8624755	Ref.Nr.: 30645447	Ref.Nr.: 1510474	Ref.Nr.: 9157115	Ref.Nr.: 1305329	Ref.Nr.: 8659000	Ref.Nr.: 30748811

Article Description



Article Nr.

Fitting Position



### S80 II (AS)

03/2006 →

Protective Cap/Bellow, shock absorber	1.6 D DRIVE, 1.6 DRIVE, 2.0, 2.0 FlexFuel, 2.0 T, 2.0 TDi, 2.4 D, 2.5 T, 2.5 T AWD, 2.5 T FlexFuel, 3.2, 3.2 AWD, 4.4 V8 AWD, D3, D4, D5, D5 AWD, T4, T4F, T5, T6 AWD		F8-7838	⊕ ⊕	H=250
Control Arm-/Trailing Arm Bush	2.5 T AWD, 3.2 AWD, 4.4 V8 AWD, D5 AWD, T6 AWD		F8-7877	⊕	
Control Arm-/Trailing Arm Bush	1.6 D DRIVE, 1.6 DRIVE, 2.0, 2.0 FlexFuel, 2.0 T, 2.0 TDi, 2.4 D, 2.5 T, 2.5 T AWD, 2.5 T FlexFuel, 3.2, 3.2 AWD, 4.4 V8 AWD, D3, D5, D5 AWD, T4, T4F, T5, T6 AWD		F8-7878	⊕	
Control Arm-/Trailing Arm Bush	1.6 D DRIVE, 1.6 DRIVE, 2.0, 2.0 FlexFuel, 2.0 T, 2.0 TDi, 2.4 D, 2.5 T, 2.5 T FlexFuel, 3.2, D3, D4, D5, T4, T4F, T5		F8-8069	⊕	
Control Arm-/Trailing Arm Bush	1.6 D DRIVE, 1.6 DRIVE, 2.0, 2.0 FlexFuel, 2.0 T, 2.0 TDi, 2.4 D, 2.5 T, 2.5 T AWD, 2.5 T FlexFuel, 3.2, 3.2 AWD, 4.4 V8 AWD, D3, D4, D5, D5 AWD, T4, T4F, T5, T6 AWD		F8-8074	⊕	
Control Arm-/Trailing Arm Bush	1.6 D DRIVE, 1.6 DRIVE, 2.0, 2.0 FlexFuel, 2.0 T, 2.0 TDi, 2.4 D, 2.5 T, 2.5 T AWD, 2.5 T FlexFuel, 3.2, 3.2 AWD, 4.4 V8 AWD, D3, D4, D5, D5 AWD, T4, T4F, T5, T6 AWD		F8-8075	⊕	

### S90

11/1996 → 10/1998

Control Arm-/Trailing Arm Bush	2.9		F8-5106	⊕ ⊕	H=27; d=18; D=51
Control Arm-/Trailing Arm Bush	2.9		F8-5140	⊕ ⊕	d=14; L=67.5; D=47
Control Arm-/Trailing Arm Bush	2.9		F8-5242	⊕ ⊕	H=65; d=12; D1=21; D2=40
Control Arm-/Trailing Arm Bush	2.9		F8-5245		
Suspension, panhard rod	All Models		F8-5735	⊕	H=40; d=20; D=40.5
Suspension, panhard rod	All Models		F8-5736	⊕	H=50; d=12; D=40
Top Strut Mounting	2.9		F8-5983		d=18
Top Strut Mounting	2.9		F8-5984		d=18
Anti-Friction Bearing	2.9		F8-6267		H=12; W=91
Mounting, automatic transmission	All Models		F8-6549		
Bearing Bush, stabiliser	2.9		F8-6769	⊕ ⊕	H=53.8; d=20.8

### V40 Estate (VW)

07/1995 → 06/2004

Dust Cover Kit, shock absorber	1.6, 1.8, 1.8 i, 1.9 DI, 1.9 T4, 1.9 TD, 2.0, 2.0 T		AK-735024	⊕ ⊕	
Dust Cover Kit, shock absorber	1.6, 1.8, 1.8 i, 1.9 DI, 1.9 TD, 2.0, 2.0 T		AK-735121	⊕ ⊕	
Dust Cover Kit, shock absorber	1.8 i, 1.9 DI, 2.0 T, 2.0 T4		AK-735123	⊕ ⊕	

<b>AK-735024</b>	<b>AK-735121</b>	<b>AK-735123</b>	<b>F5-1014</b>	<b>F8-5106</b>	<b>F8-5140</b>	<b>F8-5242</b>
Ref.Nr.:	Ref.Nr.:	Ref.Nr.: 30884200	Ref.Nr.: 8641982	Ref.Nr.: 013595996	Ref.Nr.: 013296553	Ref.Nr.: 6819537
<b>F8-5245</b>	<b>F8-5735</b>	<b>F8-5736</b>	<b>F8-5983</b>	<b>F8-5984</b>	<b>F8-6267</b>	<b>F8-6549</b>
Ref.Nr.: 9191537	Ref.Nr.: 1330427	Ref.Nr.: 1229715	Ref.Nr.: 1387188	Ref.Nr.: 1273747	Ref.Nr.: 1273747	Ref.Nr.: 1328900
<b>F8-6769</b>	<b>F8-7838</b>	<b>F8-7877</b>	<b>F8-7878</b>	<b>F8-8069</b>	<b>F8-8074</b>	<b>F8-8075</b>
Ref.Nr.: 1359808	Ref.Nr.: 1305329	Ref.Nr.: 1865033	Ref.Nr.: 31 277 755	Ref.Nr.: 31387282	Ref.Nr.: 7G9J-3A262-AB	Ref.Nr.: 1507181

**Article Description****Article Nr.****Fitting Position**

<b>V40 Estate (VW)</b>		<b>07/1995 → 06/2004</b>	
Alternator Freewheel Clutch	1.9 DI, 1.9 TD		<b>F5-1014</b>
Alternator Freewheel Clutch	1.9 DI, 1.9 TD		<b>F5-1025</b>
Alternator Freewheel Clutch	1.6, 1.8, 1.8 i, 1.9 T4, 2.0, 2.0 T, 2.0 T4		<b>F5-1087</b>
Control Arm-/Trailing Arm Bush	All Models		<b>F8-5249</b>
Top Strut Mounting	1.6, 1.8, 1.8 i, 1.9 DI, 1.9 T4, 1.9 TD, 2.0, 2.0 T		<b>F8-5933</b>
Anti-Friction Bearing	1.6, 1.8, 1.8 i, 1.9 DI, 2.0, 2.0 T4	06/2001 →;	<b>F8-6262</b>
Anti-Friction Bearing	1.8 i, 2.0 T		<b>F8-6262</b>
Top Strut Mounting	1.6, 1.8, 1.8 i, 1.9 DI, 1.9 T4, 2.0, 2.0 T	01/2000 →;	<b>F8-6337</b>
Top Strut Mounting	1.8 i, 1.9 DI, 2.0 T, 2.0 T4		<b>F8-6337</b>
Rod/Strut, wheel suspension	All Models		<b>F8-6469</b>
Control Arm-/Trailing Arm Bush	All Models		<b>F8-6696</b>
Control Arm-/Trailing Arm Bush	All Models		<b>F8-6772</b>
Engine Mounting	1.9 DI, 1.9 T4, 1.9 TD, 2.0, 2.0 T		<b>F8-6994</b>
Bellow, steering	1.6, 1.8, 1.8 i, 1.9 DI, 1.9 T4, 1.9 TD, 2.0, 2.0 T, 2.0 T4	with clamps	<b>LM-10061S</b>
Bellow Set, drive shaft	1.9 T4, 2.0, 2.0 T, 2.0 T4	with clamps;	<b>MK-810160</b>
<b>V40 Hatchback</b>		<b>03/2012 → 03/2015</b>	
Protective Cap/Bellow, shock absorber	D2, D3, D4, T2 GTDi, T3 GTDi, T4, T4 AWD, T4 GTDi, T5, T5 AWD		<b>F8-7838</b>
<b>V50 (MW)</b>		<b>04/2004 →</b>	
Dust Cover Kit, shock absorber	1.6, 1.6 D, 1.8, 2.0, 2.0 D, 2.4, 2.4 D5, T5, T5 AWD		<b>AK-735305</b>
Dust Cover Kit, shock absorber	1.6, 1.6 D, 1.8, 2.0, 2.0 D, 2.4, 2.4 D5, T5, T5 AWD		<b>AK-735306</b>
Alternator Freewheel Clutch	1.6 D, 2.0 D	Alternator Charge Current [A]: 120; Manufacturer Restriction: Denso	<b>F5-1072</b>
Alternator Freewheel Clutch	2.4, 2.4 AWD, 2.4 D5, 2.4 Tdi, T5, T5 AWD	Alternator Nr: 104210-3550, 104210-3560, 104210-4640; Manufacturer Restriction: Denso	<b>F5-1151</b>
Top Strut Mounting	All Models		<b>F8-6210</b>
Anti-Friction Bearing	1.6, 1.6 D, 1.8, 1.8 FlexFuel, 2.0, 2.0 D, 2.4, 2.4 AWD, 2.4 D5, 2.4 Tdi, T5, T5 AWD		<b>F8-6268</b>
Top Strut Mounting	1.6, 1.6 D2, 1.8, 1.8 FlexFuel, 2.0, 2.0 D, 2.0 FlexFuel, 2.4, 2.4 AWD, 2.4 D5, 2.4 Tdi, D3, D4, T5, T5 AWD		<b>F8-6357</b>
Mounting, axle beam	1.6, 1.6 D, 1.6 D2, 1.8, 1.8 FlexFuel, 2.0, 2.0 D, 2.0 FlexFuel, 2.4, 2.4 AWD, 2.4 D5, 2.4 Tdi, T5, T5 AWD		<b>F8-6638</b>
Belt Pulley, crankshaft	1.6 D	Number of Ribs: 6	<b>F8-7082</b>

<b>AK-735305</b>	<b>AK-735306</b>	<b>F5-1014</b>	<b>F5-1025</b>	<b>F5-1072</b>	<b>F5-1087</b>	<b>F5-1151</b>
Ref.Nr.: 30666842	Ref.Nr.: 30666243	Ref.Nr.: 8641982	Ref.Nr.: 23151-00Q0B	Ref.Nr.: 30667067	Ref.Nr.: 30782701	Ref.Nr.:
<b>F8-5249</b>	<b>F8-5933</b>	<b>F8-6210</b>	<b>F8-6262</b>	<b>F8-6268</b>	<b>F8-6337</b>	<b>F8-6357</b>
Ref.Nr.: 30818467	Ref.Nr.: 30818465	Ref.Nr.: 3M513K155DC	Ref.Nr.: 97BG-3K099-AA	Ref.Nr.: 30639948	Ref.Nr.: 30616824	Ref.Nr.: 30714395
<b>F8-6469</b>	<b>F8-6638</b>	<b>F8-6696</b>	<b>F8-6772</b>	<b>F8-6994</b>	<b>F8-7082</b>	<b>F8-7156</b>
Ref.Nr.: 30620785	Ref.Nr.: C2Y6-28-460	Ref.Nr.: MR102063	Ref.Nr.: 30620972	Ref.Nr.: 30611144	Ref.Nr.: 0515.R0	Ref.Nr.: BP4L-34-380C

<b>Article Description</b>			<b>Article Nr.</b>	<b>Fitting Position</b>	
----------------------------	--	--	--------------------	-------------------------	--

<b>V50 (MW)</b>		<b>04/2004 →</b>			
Top Strut Mounting	1.6, 1.6 D, 1.8, 1.8 FlexFuel, 2.0, 2.0 D, 2.4, 2.4 AWD, 2.4 D5, 2.4 Tdi, T5, T5 AWD		<b>F8-7156</b>		
Protective Cap/Bellow, shock absorber	All Models		<b>F8-7838</b>		H=250
Control Arm-/Trailing Arm Bush	1.6, 1.6 D, 1.8, 1.8 FlexFuel, 2.0, 2.0 D, 2.0 FlexFuel, 2.4, 2.4 AWD, 2.4 D5, 2.4 Tdi, T5, T5 AWD		<b>F8-8078</b>		
Engine Mounting	1.6, 1.6 D, 1.8, 1.8 FlexFuel, 2.0, 2.0 D, 2.0 FlexFuel, 2.4, 2.4 AWD, 2.4 D5, 2.4 Tdi, T5, T5 AWD		<b>F8-8140</b>		
<b>V60</b>		<b>09/2010 →</b>			
Alternator Freewheel Clutch	2.0 T, T5		<b>F5-1134</b>		
Anti-Friction Bearing	1.6 DRIVE, 2.0 T, 2.4 D5, 2.4 D5 AWD, 2.4 Hybrid AWD, D3, D5, D5 AWD, T3, T4, T4F, T5, T6 AWD		<b>F8-7607</b>		
Protective Cap/Bellow, shock absorber	1.6 DRIVE, 2.0 T, 2.4 D5, 2.4 D5 AWD, 2.4 Hybrid AWD, D3, D4, D4 AWD, D5, D5 AWD, T3, T4, T4F, T5, T6, T6 AWD		<b>F8-7838</b>		H=250
Control Arm-/Trailing Arm Bush	2.4 D5 AWD, D5 AWD, T6 AWD		<b>F8-7877</b>		
Control Arm-/Trailing Arm Bush	1.6 DRIVE, 2.0 T, 2.4 D5, 2.4 D5 AWD, 2.4 Hybrid AWD, D3, D5, D5 AWD, T3, T4, T4F, T5, T6 AWD		<b>F8-7878</b>		
Control Arm-/Trailing Arm Bush	1.6 DRIVE, 2.0 T, 2.4 D5, D3, D4, D5, T3, T4, T4F, T5, T6		<b>F8-8069</b>		
Control Arm-/Trailing Arm Bush	1.6 DRIVE, 2.0 T, 2.4 D5, 2.4 D5 AWD, 2.4 Hybrid AWD, D3, D5, D5 AWD, T3, T4, T4F, T5, T6 AWD		<b>F8-8074</b>		
Control Arm-/Trailing Arm Bush	1.6 DRIVE, 2.0 T, 2.4 D5, 2.4 D5 AWD, 2.4 Hybrid AWD, D3, D5, D5 AWD, T3, T4, T4F, T5, T6 AWD		<b>F8-8075</b>		
<b>V70 (LV)</b>		<b>11/1996 → 05/2000</b>			
Dust Cover Kit, shock absorber	2.0, 2.0 Turbo, 2.0 Turbo AWD, 2.3 AWD, 2.3 T AWD, 2.3 T-5, 2.3 T-5 AWD, 2.3 Turbo, 2.4, 2.4 Bifuel, 2.4 Turbo, 2.5, 2.5 AWD, 2.5 Bifuel, 2.5 TDI, 2.5 Turbo AWD		<b>AK-735003</b>		
Rubber Buffer, suspension	2.0, 2.0 Turbo, 2.3 T-5, 2.3 Turbo, 2.4, 2.4 Bifuel, 2.4 Turbo, 2.5, 2.5 Bifuel, 2.5 TDI		<b>AK-735311</b>		
Alternator Freewheel Clutch	2.0, 2.0 Turbo, 2.0 Turbo AWD, 2.3 AWD, 2.3 T AWD, 2.3 T-5, 2.3 T-5 AWD, 2.3 Turbo, 2.4 Turbo, 2.5 Bifuel, 2.5 Turbo AWD		<b>F5-1015</b>		
Alternator Freewheel Clutch	2.4 AWD		<b>F5-1031</b>		
Alternator Freewheel Clutch	2.0, 2.0 Turbo, 2.0 Turbo AWD, 2.3 T AWD, 2.3 T-5, 2.3 T-5 AWD, 2.3 Turbo, 2.4, 2.4 Turbo, 2.5, 2.5 Turbo AWD	Alternator Charge Current [A]: 120; Manufacturer Restriction: Bosch	<b>F5-1032</b>		
Mounting, automatic transmission	2.0, 2.0 Turbo, 2.0 Turbo AWD, 2.3 T AWD, 2.3 T-5, 2.3 Turbo, 2.4, 2.4 Turbo, 2.5, 2.5 Bifuel, 2.5 TDI, 2.5 Turbo AWD		<b>F8-5027</b>		H=59; d=12.2; D=60.5
Mounting, automatic transmission	2.0, 2.0 Turbo, 2.0 Turbo AWD, 2.3 T AWD, 2.3 T-5, 2.3 Turbo, 2.4, 2.4 Turbo, 2.5, 2.5 Bifuel, 2.5 TDI, 2.5 Turbo AWD		<b>F8-5027</b>		H=59; d=12.2; D=60.5

<b>AK-735003</b>	<b>AK-735311</b>	<b>F5-1015</b>	<b>F5-1031</b>	<b>F5-1032</b>	<b>F5-1134</b>	<b>F8-5027</b>
Ref.Nr.:	Ref.Nr.: 9140177	Ref.Nr.: 9404328	Ref.Nr.: 021903119H	Ref.Nr.: 9459747	Ref.Nr.: 31285489	Ref.Nr.: 9434263
<b>F8-5254</b>	<b>F8-7156</b>	<b>F8-7607</b>	<b>F8-7838</b>	<b>F8-7877</b>	<b>F8-7878</b>	<b>F8-8069</b>
Ref.Nr.: 6819057	Ref.Nr.: BP4L-34-380C	Ref.Nr.: 1510474	Ref.Nr.: 1305329	Ref.Nr.: 1865033	Ref.Nr.: 31 277 755	Ref.Nr.: 31387282
<b>F8-8074</b>	<b>F8-8075</b>	<b>F8-8078</b>	<b>F8-8140</b>			
Ref.Nr.: 7G9J-3A262-AB	Ref.Nr.: 1507181	Ref.Nr.: 3M5J-3A262-BP	Ref.Nr.: 30778647			

**Article Description****Article Nr.****Fitting Position**

<b>V70 (LV)</b>		<b>11/1996 → 05/2000</b>	
Control Arm-/Trailing Arm Bush	2.0, 2.0 Turbo, 2.0 Turbo AWD, 2.3 T-5, 2.3 T-5 AWD, 2.4 Bifuel, 2.4 Turbo, 2.5, 2.5 Bifuel, 2.5 TDI, 2.5 Turbo AWD		<b>F8-5254</b>
Control Arm-/Trailing Arm Bush	2.0, 2.0 Turbo, 2.0 Turbo AWD, 2.3 T-5, 2.3 T-5 AWD, 2.4 Bifuel, 2.4 Turbo, 2.5, 2.5 Bifuel, 2.5 TDI, 2.5 Turbo AWD		<b>F8-5254</b>
Control Arm-/Trailing Arm Bush	2.3 T AWD	B 5244 S	<b>F8-5254</b>
Control Arm-/Trailing Arm Bush	2.4	B 5244 S2	<b>F8-5254</b>
Control Arm-/Trailing Arm Bush	2.4	B 5254 S	<b>F8-5254</b>
Top Strut Mounting	2.0, 2.0 Turbo, 2.0 Turbo AWD, 2.3 T AWD, 2.3 T-5, 2.3 Turbo, 2.4, 2.4 Turbo, 2.5, 2.5 TDI, 2.5 Turbo AWD	03/2000 →;	<b>F8-5570</b>
Top Strut Mounting	2.0, 2.3 AWD, 2.3 T-5 AWD, 2.4, 2.4 AWD, 2.4 Bifuel, 2.5 AWD, 2.5 Bifuel, 2.5 TDi AWD		<b>F8-5570</b>
Top Strut Mounting	2.0, 2.0 Turbo, 2.0 Turbo AWD, 2.3 AWD, 2.3 T AWD, 2.3 T-5, 2.3 T-5 AWD, 2.3 Turbo, 2.4, 2.4 AWD, 2.4 Bifuel, 2.4 Turbo, 2.5, 2.5 AWD, 2.5 Bifuel, 2.5 TDI, 2.5 TDi AWD, 2.5 Turbo AWD		<b>F8-5915</b>
Rubber Buffer, suspension	2.0, 2.0 Turbo, 2.0 Turbo AWD, 2.3 AWD, 2.3 T AWD, 2.3 T-5, 2.3 T-5 AWD, 2.3 Turbo, 2.4, 2.4 Bifuel, 2.4 Turbo, 2.5, 2.5 AWD, 2.5 Bifuel, 2.5 TDI, 2.5 Turbo AWD		<b>F8-5919</b>
Rubber Buffer, suspension	2.0, 2.0 Turbo, 2.3 AWD, 2.3 T-5, 2.4, 2.4 Turbo, 2.5, 2.5 TDI		<b>F8-5920</b>
Rubber Buffer, suspension	2.0, 2.0 Turbo, 2.3 AWD, 2.3 T-5, 2.4, 2.4 Turbo, 2.5, 2.5 TDI		<b>F8-5921</b>
Rubber Buffer, suspension	2.0, 2.0 Turbo, 2.3 AWD, 2.3 T-5, 2.4, 2.4 Turbo, 2.5, 2.5 TDI		<b>F8-5922</b>
Top Strut Mounting	2.0, 2.0 Turbo, 2.0 Turbo AWD, 2.3 AWD, 2.3 T AWD, 2.3 T-5, 2.3 T-5 AWD, 2.3 Turbo, 2.4, 2.4 Bifuel, 2.4 Turbo, 2.5, 2.5 AWD, 2.5 Bifuel, 2.5 TDI	;	<b>F8-5929</b>
Top Strut Mounting	2.0, 2.4 AWD		<b>F8-5929</b>
Top Strut Mounting	2.5 Turbo AWD	B 5254 T;	<b>F8-5929</b>
Repair Kit, suspension strut	2.0, 2.0 Turbo, 2.0 Turbo AWD, 2.3 T AWD, 2.3 T-5, 2.3 T-5 AWD, 2.3 Turbo, 2.4, 2.4 Bifuel, 2.4 Turbo, 2.5, 2.5 AWD, 2.5 Bifuel, 2.5 TDI, 2.5 Turbo AWD		<b>F8-6385</b>
Control Arm-/Trailing Arm Bush	2.0, 2.0 Turbo, 2.0 Turbo AWD, 2.3 T AWD, 2.3 T-5, 2.3 T-5 AWD, 2.3 Turbo, 2.4, 2.4 Bifuel, 2.4 Turbo, 2.5, 2.5 AWD, 2.5 Bifuel, 2.5 TDI, 2.5 Turbo AWD		<b>F8-6548</b>
Mounting, axle beam	2.0, 2.0 Turbo, 2.0 Turbo AWD, 2.3 AWD, 2.3 T AWD, 2.3 T-5, 2.3 T-5 AWD, 2.3 Turbo, 2.4, 2.4 AWD, 2.4 Bifuel, 2.4 Turbo, 2.5, 2.5 AWD, 2.5 Bifuel, 2.5 TDI, 2.5 TDi AWD, 2.5 Turbo AWD		<b>F8-6759</b>

<b>F8-5254</b>	<b>F8-5570</b>	<b>F8-5915</b>	<b>F8-5919</b>	<b>F8-5920</b>	<b>F8-5921</b>	<b>F8-5922</b>
Ref.Nr.: 6819057	Ref.Nr.: 9461728	Ref.Nr.: 31200599	Ref.Nr.: 9140067	Ref.Nr.: 9140129	Ref.Nr.: 3516327	Ref.Nr.: 3546705
<b>F8-5929</b>	<b>F8-6385</b>	<b>F8-6548</b>	<b>F8-6759</b>	<b>F8-7694</b>		
Ref.Nr.: 3516151	Ref.Nr.: 9173203	Ref.Nr.: 271631	Ref.Nr.: 3507924	Ref.Nr.: 3530050		

Article Description			Article Nr.	Fitting Position	
---------------------	--	--	-------------	------------------	--

<b>V70 (LV)</b>			11/1996 → 05/2000		
Control Arm-/Trailing Arm Bush	2.0, 2.0 Turbo, 2.3 T-5, 2.3 Turbo, 2.4, 2.4 Bifuel, 2.4 Turbo, 2.5, 2.5 Bifuel, 2.5 TDI		F8-7694		
Control Arm-/Trailing Arm Bush	2.0, 2.0 Turbo, 2.3 T-5, 2.3 Turbo, 2.4, 2.4 Bifuel, 2.4 Turbo, 2.5, 2.5 Bifuel, 2.5 TDI	Aluminium	F8-7695		
Suspension Kit	2.0, 2.0 Turbo, 2.3 T-5, 2.3 Turbo, 2.4, 2.4 Bifuel, 2.4 Turbo, 2.5, 2.5 Bifuel, 2.5 TDI	Aluminium; with fastening material	F8-7695S		
Control Arm-/Trailing Arm Bush	2.0, 2.0 Turbo, 2.3 T-5, 2.3 Turbo, 2.4, 2.4 Bifuel, 2.4 Turbo, 2.5, 2.5 Bifuel, 2.5 TDI	Aluminium	F8-7696		
Suspension Kit	2.0, 2.0 Turbo, 2.3 T-5, 2.3 Turbo, 2.4, 2.4 Bifuel, 2.4 Turbo, 2.5, 2.5 Bifuel, 2.5 TDI	Aluminium; with fastening material	F8-7696S		
Engine Mounting	2.0, 2.0 Turbo, 2.3 T-5, 2.4, 2.4 Bifuel, 2.4 Turbo, 2.5, 2.5 Bifuel		F8-8148		
Engine Mounting	2.0, 2.0 Turbo, 2.3 T-5, 2.4 Turbo		F8-8190		
<b>V70 Mk II (SW)</b>			03/2000 → 08/2007		
Dust Cover Kit, shock absorber	2.0 T, 2.3 AWD, 2.3 T5, 2.4, 2.4 Bifuel, 2.4 D, 2.4 D5, 2.4 D5 AWD, 2.4 T, 2.4 T AWD, 2.4 T5, 2.5 R Sport, 2.5 T, 2.5 T AWD, 2.5 TDI, R 2.5 T AWD		AK-735003		
Alternator Freewheel Clutch	2.3, 2.3 AWD, 2.3 T5		F5-1015		
Alternator Freewheel Clutch	2.4 D, 2.4 D5, 2.4 D5 AWD, 2.5 R Sport, 2.5 T, 2.5 T AWD, 2.5 TDI, R 2.5 T AWD		F5-1031		
Alternator Freewheel Clutch	2.0 T	Alternator Charge Current [A]: 140	F5-1032		
Top Strut Mounting	2.0 T, 2.3, 2.3 AWD, 2.3 T5, 2.4, 2.4 AWD, 2.4 Bifuel, 2.4 D, 2.4 D5, 2.4 D5 AWD, 2.4 T, 2.4 T AWD, 2.4 T5, 2.5 R Sport, 2.5 T, 2.5 T AWD, 2.5 TDI, R 2.5 T AWD		F8-5570		
Top Strut Mounting	2.0 T, 2.3, 2.3 AWD, 2.3 T5, 2.4, 2.4 AWD, 2.4 Bifuel, 2.4 D, 2.4 D5, 2.4 D5 AWD, 2.4 T, 2.4 T AWD, 2.4 T5, 2.5 R Sport, 2.5 T, 2.5 T AWD, 2.5 TDI, R 2.5 T AWD	ch.→546642, 547726	F8-5915		
Rubber Buffer, suspension	2.4 T		F8-5919		D=20; H=51
Top Strut Mounting	2.0 T, 2.3, 2.3 AWD, 2.3 T5, 2.4, 2.4 AWD, 2.4 Bifuel, 2.4 D, 2.4 D5, 2.4 D5 AWD, 2.4 T, 2.4 T AWD, 2.4 T5, 2.5 R Sport, 2.5 T, 2.5 T AWD, 2.5 TDI, R 2.5 T AWD	ch.546643, 547727→	F8-6014		
Control Arm-/Trailing Arm Bush	2.0 T, 2.3 AWD, 2.3 T5, 2.4, 2.4 Bifuel, 2.4 D, 2.4 D5, 2.4 D5 AWD, 2.4 T, 2.4 T AWD, 2.5 T AWD, 2.5 TDI, R 2.5 T AWD		F8-6166		L=123; D=48
Control Arm-/Trailing Arm Bush	2.0 T, 2.3 AWD, 2.3 T5, 2.4, 2.4 D, 2.4 D5, 2.4 D5 AWD, 2.4 T, 2.4 T AWD, 2.5 T AWD, 2.5 TDI		F8-6167		H1=29, 50; d=14; D=53
Top Strut Mounting	2.0 T, 2.3 AWD, 2.3 T5, 2.4, 2.4 D, 2.4 D5, 2.4 T, 2.5 TDI, R 2.5 T AWD		F8-6198		
Repair Kit, suspension strut	2.0 T, 2.3 T5, 2.4, 2.4 Bifuel, 2.4 D, 2.4 D5, 2.4 D5 AWD, 2.4 T, 2.4 T AWD, 2.4 T5, 2.5 T, 2.5 T AWD, 2.5 TDI, R 2.5 T AWD	ch.546643, 547727→	F8-6384		
Repair Kit, suspension strut	2.0 T, 2.3 T5, 2.4, 2.4 Bifuel, 2.4 D, 2.4 D5, 2.4 D5 AWD, 2.4 T, 2.4 T AWD, 2.4 T5, 2.5 T, 2.5 T AWD, 2.5 TDI	ch.→546642, 547726	F8-6385		

<b>AK-735003</b>	<b>F5-1015</b>	<b>F5-1031</b>	<b>F5-1032</b>	<b>F8-5570</b>	<b>F8-5915</b>	<b>F8-5919</b>
Ref.Nr.:	Ref.Nr.: 9404328	Ref.Nr.: 021903119H	Ref.Nr.: 9459747	Ref.Nr.: 9461728	Ref.Nr.: 31200599	Ref.Nr.: 9140067
<b>F8-6014</b>	<b>F8-6166</b>	<b>F8-6167</b>	<b>F8-6198</b>	<b>F8-6384</b>	<b>F8-6385</b>	<b>F8-6759</b>
Ref.Nr.: 30714968	Ref.Nr.: 9173618	Ref.Nr.: 8630604	Ref.Nr.: 9157745	Ref.Nr.: 30714968	Ref.Nr.: 9173203	Ref.Nr.: 3507924
<b>F8-7694</b>	<b>F8-7695</b>	<b>F8-7695S</b>	<b>F8-7696</b>	<b>F8-7696S</b>	<b>F8-8148</b>	<b>F8-8190</b>
Ref.Nr.: 3530050	Ref.Nr.: 3530202	Ref.Nr.: 3530202	Ref.Nr.: 3516496	Ref.Nr.: 3516496	Ref.Nr.: 8659000	Ref.Nr.: 8631698



**Article Description****Article Nr.****Fitting Position**

<b>V70 Mk II (SW)</b>			<b>03/2000 → 08/2007</b>	
Mounting, axle beam	2.0 T, 2.3 AWD, 2.3 T5, 2.4, 2.4 Bifuel, 2.4 D, 2.4 D5, 2.4 D5 AWD, 2.4 T, 2.4 T AWD, 2.4 T5, 2.5 T, 2.5 T AWD, 2.5 TDI, R 2.5 T AWD		<b>F8-6759</b>	
Engine Mounting	2.4 D, 2.4 D5, 2.5 TDI		<b>F8-6992</b>	
Engine Mounting	2.4 D, 2.4 D5, 2.4 D5 AWD		<b>F8-6993</b>	
Rubber Buffer, suspension	2.0 T, 2.3, 2.3 AWD, 2.3 T5, 2.4, 2.4 AWD, 2.4 Bifuel, 2.4 D, 2.4 D5, 2.4 D5 AWD, 2.4 T, 2.4 T AWD, 2.4 T5, 2.5 R Sport, 2.5 T, 2.5 T AWD, 2.5 TDI, R 2.5 T AWD	<b>ST</b>	<b>F8-7680</b>	H=68
Engine Mounting	2.0 T, 2.3 T5, 2.4, 2.4 Bifuel, 2.4 T, 2.5 T		<b>F8-8148</b>	
Engine Mounting	2.0 T, 2.3 T5, 2.4, 2.4 Bifuel, 2.4 D, 2.4 D5, 2.4 D5 AWD, 2.4 T, 2.4 T AWD, 2.4 T5, 2.5 T, 2.5 T AWD, R 2.5 T AWD		<b>F8-8156</b>	
Bellow Set, drive shaft	2.0 T, 2.3 T5, 2.4 T, 2.4 T AWD	with clamps;	<b>MK-810160</b>	L=116
Bellow Set, drive shaft	2.4 D5	with clamps	<b>MK-810160</b>	L=116
<b>V70 III (BW)</b>			<b>08/2007 →</b>	
Dust Cover Kit, shock absorber	2.4 D, 2.5 T, 3.2 AWD, D5, T6 AWD		<b>AK-735003</b>	
Alternator Freewheel Clutch	2.0 D		<b>F5-1046</b>	
Alternator Freewheel Clutch	2.0 D	Alternator Charge Current [A]: 120; Manufacturer Restriction: Denso	<b>F5-1072</b>	
Alternator Freewheel Clutch	2.0, 2.0 FlexiFuel		<b>F5-1075</b>	
Alternator Freewheel Clutch	2.0 T, T5		<b>F5-1134</b>	
Engine Mounting	D5		<b>F8-6992</b>	
Anti-Friction Bearing	1.6 D, 1.6 DRIVE, 1.6 T4F, 2.0, 2.0 D, 2.0 FlexiFuel, 2.0 T, 2.4 D, 2.5 T, 2.5 T FlexiFuel, 3.2, 3.2 AWD, D3, D4 AWD, D5, D5 AWD, T4, T5, T6 AWD		<b>F8-7607</b>	
Rubber Buffer, suspension	2.4 D	<b>ST</b>	<b>F8-7680</b>	H=68
Protective Cap/Bellow, shock absorber	1.6 D, 1.6 DRIVE, 1.6 T4F, 2.0, 2.0 BiFuel, 2.0 D, 2.0 FlexiFuel, 2.0 T, 2.4 D, 2.5 T, 2.5 T FlexiFuel, 3.2, 3.2 AWD, D3, D4, D4 AWD, D5, D5 AWD, T4, T5, T6 AWD		<b>F8-7838</b>	H=250
Control Arm-/Trailing Arm Bush	3.2 AWD, D5 AWD, T6 AWD		<b>F8-7877</b>	
Control Arm-/Trailing Arm Bush	1.6 D, 1.6 DRIVE, 1.6 T4F, 2.0, 2.0 D, 2.0 FlexiFuel, 2.0 T, 2.4 D, 2.5 T, 2.5 T FlexiFuel, 3.2, 3.2 AWD, D3, D5, D5 AWD, T4, T5, T6 AWD		<b>F8-7878</b>	
Control Arm-/Trailing Arm Bush	1.6 D, 1.6 DRIVE, 1.6 T4F, 2.0, 2.0 D, 2.0 FlexiFuel, 2.0 T, 2.4 D, 2.5 T, 2.5 T FlexiFuel, 3.2, D3, D5, T4, T5		<b>F8-8069</b>	
Control Arm-/Trailing Arm Bush	1.6 D, 1.6 DRIVE, 1.6 T4F, 2.0, 2.0 D, 2.0 FlexiFuel, 2.0 T, 2.4 D, 2.5 T, 2.5 T FlexiFuel, 3.2, 3.2 AWD, D3, D5, D5 AWD, T4, T5, T6 AWD		<b>F8-8074</b>	
Control Arm-/Trailing Arm Bush	1.6 D, 1.6 DRIVE, 1.6 T4F, 2.0, 2.0 D, 2.0 FlexiFuel, 2.0 T, 2.4 D, 2.5 T, 2.5 T FlexiFuel, 3.2, 3.2 AWD, D3, D5, D5 AWD, T4, T5, T6 AWD		<b>F8-8075</b>	

<b>AK-735003</b>	<b>F5-1046</b>	<b>F5-1072</b>	<b>F5-1075</b>	<b>F5-1134</b>	<b>F8-6759</b>	<b>F8-6992</b>
Ref.Nr.:	Ref.Nr.: 30667687	Ref.Nr.: 30667067	Ref.Nr.: 30667610	Ref.Nr.: 31285489	Ref.Nr.: 3507924	Ref.Nr.: 8624755
<b>F8-6993</b>	<b>F8-7607</b>	<b>F8-7680</b>	<b>F8-7838</b>	<b>F8-7877</b>	<b>F8-7878</b>	<b>F8-8069</b>
Ref.Nr.: 30645447	Ref.Nr.: 1510474	Ref.Nr.: 9157115	Ref.Nr.: 1305329	Ref.Nr.: 1865033	Ref.Nr.: 31 277 755	Ref.Nr.: 31387282
<b>F8-8074</b>	<b>F8-8075</b>	<b>F8-8148</b>	<b>F8-8156</b>	<b>MK-810160</b>		
Ref.Nr.: 7G9J-3A262-AB	Ref.Nr.: 1507181	Ref.Nr.: 8659000	Ref.Nr.: 30748811	Ref.Nr.: 3D0 498 201		

Article Description



Article Nr.

Fitting Position



### V90 Estate

11/1996 → 12/1998

Control Arm-/Trailing Arm Bush	2.9		F8-5106		H=27; d=18; D=51
Control Arm-/Trailing Arm Bush	2.9		F8-5140		d=14; L=67.5; D=47
Control Arm-/Trailing Arm Bush	2.9		F8-5242		H=65; d=12; D1=21; D2=40
Control Arm-/Trailing Arm Bush	2.9		F8-5245		
Suspension, panhard rod	All Models		F8-5735		H=40; d=20; D=40.5
Suspension, panhard rod	All Models		F8-5736		H=50; d=12; D=40
Top Strut Mounting	2.9		F8-5983		d=18
Top Strut Mounting	2.9		F8-5984		d=18
Anti-Friction Bearing	2.9		F8-6267		H=12; W=91
Mounting, automatic transmission	All Models		F8-6549		
Bearing Bush, stabiliser	2.9		F8-6769		H=53.8; d=20.8

### XC60

05/2008 → 06/2011

Alternator Freewheel Clutch	2.0 T, T5		F5-1134		
Anti-Friction Bearing	2.0 T, 2.4 D, 2.4 D AWD, 3.2 AWD, D3, D5 AWD, T5, T6 AWD		F8-7607		
Protective Cap/Bellow, shock absorber	2.0 T, 2.4 D, 2.4 D AWD, 3.2 AWD, D3, D4, D4 AWD, D5, D5 AWD, T5, T6, T6 AWD		F8-7838		H=250
Control Arm-/Trailing Arm Bush	2.0 T, 2.4 D, 2.4 D AWD, 3.2 AWD, D3, D5, D5 AWD, T5, T6 AWD		F8-7878		
Control Arm-/Trailing Arm Bush	2.0 T, 2.4 D, 2.4 D AWD, 3.2 AWD, D3, D5, D5 AWD, T5, T6 AWD		F8-8069		
Control Arm-/Trailing Arm Bush	2.0 T, 2.4 D, 2.4 D AWD, 3.2 AWD, D3, D5, D5 AWD, T5, T6 AWD		F8-8074		
Control Arm-/Trailing Arm Bush	2.0 T, 2.4 D, 2.4 D AWD, 3.2 AWD, D3, D5, D5 AWD, T5, T6 AWD		F8-8075		

### XC70 CROSS COUNTRY

11/1997 → 08/2007

Dust Cover Kit, shock absorber	2.4 D5 AWD, 2.4 D5 XC AWD, 2.4 T XC AWD, 2.5 T XC AWD		AK-735130		
Alternator Freewheel Clutch	2.4 D5 XC AWD, 2.5 T XC AWD		F5-1031		
Control Arm-/Trailing Arm Bush	2.4 T XC AWD		F8-5254		H=27; d=17; D=52
Top Strut Mounting	2.4 D5 XC AWD, 2.4 T XC AWD, 2.5 T XC AWD		F8-5570		
Top Strut Mounting	2.4 D5 XC AWD, 2.4 T XC AWD, 2.5 T XC AWD	ch. → 217262	F8-5915		
Rubber Buffer, suspension	2.4 T XC AWD		F8-5919		D=20; H=51
Top Strut Mounting	2.4 D5 AWD, 2.4 D5 XC AWD, 2.4 T XC AWD, 2.5 T XC AWD	ch. 21763 →	F8-6014		

<b>AK-735130</b>	<b>F5-1031</b>	<b>F5-1134</b>	<b>F8-5106</b>	<b>F8-5140</b>	<b>F8-5242</b>	<b>F8-5245</b>
Ref.Nr.: 8672087	Ref.Nr.: 021903119H	Ref.Nr.: 31285489	Ref.Nr.: 013595996	Ref.Nr.: 013296553	Ref.Nr.: 6819537	Ref.Nr.: 9191537
<b>F8-5254</b>	<b>F8-5570</b>	<b>F8-5735</b>	<b>F8-5736</b>	<b>F8-5915</b>	<b>F8-5919</b>	<b>F8-5983</b>
Ref.Nr.: 6819057	Ref.Nr.: 9461728	Ref.Nr.: 1330427	Ref.Nr.: 1229715	Ref.Nr.: 31200599	Ref.Nr.: 9140067	Ref.Nr.: 1387188
<b>F8-5984</b>	<b>F8-6014</b>	<b>F8-6166</b>	<b>F8-6267</b>	<b>F8-6549</b>	<b>F8-6769</b>	<b>F8-7607</b>
Ref.Nr.: 1273747	Ref.Nr.: 30714968	Ref.Nr.: 9173618	Ref.Nr.: 1273747	Ref.Nr.: 1328900	Ref.Nr.: 1359808	Ref.Nr.: 1510474

**Article Description****Article Nr.****Fitting Position****XC70 CROSS COUNTRY****11/1997 → 08/2007**

Control Arm-/Trailing Arm Bush	2.4 D5 XC AWD, 2.4 T XC AWD, 2.5 T XC AWD		<b>F8-6166</b>		L=123; D=48
Control Arm-/Trailing Arm Bush	2.4 D5 XC AWD, 2.5 T XC AWD		<b>F8-6167</b>		H1=29, 50; d=14; D=53
Mounting, axle beam	2.4 D5 AWD, 2.4 D5 XC AWD, 2.4 T XC AWD, 2.5 T XC AWD		<b>F8-6759</b>		
Engine Mounting	2.4 D5 AWD, 2.4 D5 XC AWD		<b>F8-6992</b>		
Engine Mounting	2.4 D5 XC AWD		<b>F8-6993</b>		
Rubber Buffer, suspension	2.4 D5 AWD, 2.4 D5 XC AWD, 2.5 T XC AWD	<b>ST</b>	<b>F8-7680</b>		H=68
Control Arm-/Trailing Arm Bush	2.4 D5 AWD, 2.4 D5 XC AWD, 2.4 T XC AWD, 2.5 T XC AWD		<b>F8-8094</b>		
Engine Mounting	2.4 D5 AWD, 2.4 D5 XC AWD, 2.4 T XC AWD, 2.5 T XC AWD		<b>F8-8148</b>		
Engine Mounting	2.4 D5 AWD, 2.4 D5 XC AWD, 2.4 T XC AWD, 2.5 T XC AWD		<b>F8-8156</b>		
Bellow Set, drive shaft	2.4 D5 XC AWD, 2.4 T XC AWD, 2.5 T XC AWD	with clamps;	<b>MK-810160</b>		L=116

**XC70 II****08/2007 →**

Anti-Friction Bearing	2.4 D, 2.4 D AWD, 3.2 AWD, D3, D3 AWD, D5 AWD, T6 AWD		<b>F8-7607</b>		
Protective Cap/Bellow, shock absorber	2.4 D, 2.4 D AWD, 3.2, 3.2 AWD, D3, D3 AWD, D4, D4 AWD, D5 AWD, T5, T6 AWD		<b>F8-7838</b>		H=250
Control Arm-/Trailing Arm Bush	2.4 D, 2.4 D AWD, 3.2, 3.2 AWD, D3, D3 AWD, D5 AWD, T6 AWD		<b>F8-7878</b>		
Control Arm-/Trailing Arm Bush	2.4 D, 2.4 D AWD, 3.2, 3.2 AWD, D3, D3 AWD, D5 AWD, T6 AWD		<b>F8-8069</b>		
Control Arm-/Trailing Arm Bush	2.4 D, 2.4 D AWD, 3.2, 3.2 AWD, D3, D3 AWD, D5 AWD, T6 AWD		<b>F8-8074</b>		
Control Arm-/Trailing Arm Bush	2.4 D, 2.4 D AWD, 3.2, 3.2 AWD, D3, D3 AWD, D5 AWD, T6 AWD		<b>F8-8075</b>		

**XC90 I****10/2002 →**

Dust Cover Kit, shock absorber	2.5 T, 3.2, D5, T6, V8		<b>AK-735312</b>		
Dust Cover Kit, shock absorber	2.5 T, 3.2, D5, T6, V8		<b>AK-735313</b>		
Top Strut Mounting	2.5 T, 3.2, D5, T6, V8		<b>F8-6014</b>		
Control Arm-/Trailing Arm Bush	2.5 T, 3.2, D5, T6, V8		<b>F8-6718</b>		
Mounting, axle beam	2.5 T, 3.2, D5, T6, V8		<b>F8-6759</b>		
Control Arm-/Trailing Arm Bush	2.5 T, 3.2, D5, T6, V8	for OE: 30645845, 30645846	<b>F8-6776</b>		
Engine Mounting	D5		<b>F8-6992</b>		
Engine Mounting	D5		<b>F8-6993</b>		
Top Strut Mounting	2.5 T, 3.2, D5, T6, V8		<b>F8-7947</b>		

<b>AK-735312</b>	<b>AK-735313</b>	<b>F8-6014</b>	<b>F8-6166</b>	<b>F8-6167</b>	<b>F8-6718</b>	<b>F8-6759</b>
Ref.Nr.: 30645371	Ref.Nr.: 8672488	Ref.Nr.: 30714968	Ref.Nr.: 9173618	Ref.Nr.: 8630604	Ref.Nr.: 30639368	Ref.Nr.: 3507924
<b>F8-6776</b>	<b>F8-6992</b>	<b>F8-6993</b>	<b>F8-7607</b>	<b>F8-7680</b>	<b>F8-7838</b>	<b>F8-7878</b>
Ref.Nr.: 31201003	Ref.Nr.: 8624755	Ref.Nr.: 30645447	Ref.Nr.: 1510474	Ref.Nr.: 9157115	Ref.Nr.: 1305329	Ref.Nr.: 31 277 755
<b>F8-7947</b>	<b>F8-8069</b>	<b>F8-8074</b>	<b>F8-8075</b>	<b>F8-8094</b>	<b>F8-8148</b>	<b>F8-8156</b>
Ref.Nr.: 30683637	Ref.Nr.: 31387282	Ref.Nr.: 7G9J-3A262-AB	Ref.Nr.: 1507181	Ref.Nr.: 9200154	Ref.Nr.: 8659000	Ref.Nr.: 30748811

Article Description

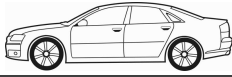











Article Nr.

Fitting Position



**XC90 I** **10/2002** →

Control Arm-/Trailing Arm Bush	2.5 T, 3.2, D5, T6, V8	ch.CH292342→	<b>F8-8094</b>	  	
Control Arm-/Trailing Arm Bush	D5		<b>F8-8094</b>	  	
Engine Mounting	2.5 T, 2.5 T AWD, D5		<b>F8-8148</b>		
Engine Mounting	2.5 T, 2.5 T AWD, D5		<b>F8-8156</b>		
Bellow Set, drive shaft	2.5 T, D5	with clamps; 	<b>MK-810160</b>		L=116

<b>F8-8094</b>	<b>F8-8148</b>	<b>F8-8156</b>	 <b>MK-810160</b>
Ref.Nr.: 9200154	Ref.Nr.: 8659000	Ref.Nr.: 30748811	Ref.Nr.: 3D0 498 201

**Article Description****Article Nr.****Fitting Position**

<b>AMAROK (2H_, S1B)</b>				<b>09/2010 →</b>	
Alternator Freewheel Clutch	2.0 BiTDI, 2.0 BiTDI 4motion, 2.0 TDI, 2.0 TDI 4motion		<b>F5-1085</b>		
Control Arm-/Trailing Arm Bush	All Models		<b>F8-5303</b>		H=60.3; d=14.1; D1=51.5; D2=40.3
Belt Pulley, crankshaft	2.0 BiTDI, 2.0 BiTDI 4motion, 2.0 TDI, 2.0 TDI 4motion	Number of Ribs: 5; Parameter: 6PK	<b>F8-6572</b>		
Belt Pulley, crankshaft	2.0 TSI	Number of Ribs: 5; Parameter: 6PK	<b>F8-7880</b>		D=143
Control Arm-/Trailing Arm Bush	All Models		<b>F8-7881</b>		H=60; d=10; D=40.5; D1=53; D2=47.5
Control Arm-/Trailing Arm Bush	All Models		<b>F8-7882</b>		H=64; H1=43.5; d=14.4; D=60.5
Control Arm-/Trailing Arm Bush	All Models		<b>F8-7883</b>		H=84; H1=69.7; d=14.3; D=46.5
Rubber Buffer, suspension	All Models		<b>F8-7898</b>		H=167
Bellow, steering	All Models	with clamps	<b>LM-10100S</b>		d1=15.5; d2=66; L [mm]=195
<b>NEW BEETLE Convertible (1Y7)</b>				<b>09/2002 → 10/2010</b>	
Dust Cover Kit, shock absorber	1.4, 1.6, 1.8 T, 1.9 TDI, 2.0		<b>AK-735095</b>		
Dust Cover Kit, shock absorber	All Models	<b>ST</b>	<b>AK-735410</b>		H=210
Alternator Freewheel Clutch	1.4, 1.6, 1.8 T, 1.9 TDI		<b>F5-1004</b>		
Alternator Freewheel Clutch	2.5		<b>F5-1076</b>		
Anti-Friction Bearing	All Models		<b>F8-3039</b>		H=14; d1=14; D=45
Top Strut Mounting	All Models		<b>F8-4067</b>		H=53; d=26; D=82
Stabiliser Mounting	1.4, 1.6, 1.8 T, 1.9 TDI	only in connection with: F8-6579; Stabi. Diam. [mm]= 19	<b>F8-5215</b>		d=17
Stabiliser Mounting	2.0	AZJ; only in connection with: F8-6579; Stabi. Diam. [mm]= 19	<b>F8-5215</b>		d=17
Top Strut Mounting	All Models	for OE: 1JC; →2005	<b>F8-5380</b>		
Rubber Buffer, suspension	1.4, 1.6, 1.8 T, 1.9 TDI, 2.0		<b>F8-5381</b>		H=37; D=76
Stabiliser Mounting	1.4, 1.6, 1.8 T, 1.9 TDI, 2.0		<b>F8-5382</b>		D=14
Engine Mounting	1.6		<b>F8-5384</b>		
Engine Mounting	2.0		<b>F8-5386</b>		
Engine Mounting	1.4		<b>F8-5388</b>		
Engine Mounting	1.6		<b>F8-5390</b>		
Spring Cap	All Models		<b>F8-5580</b>		D=92
Belt Pulley, crankshaft	1.8 T, 2.0		<b>F8-5650</b>		
Protective Cap/Bellow, shock absorber	All Models		<b>F8-5683</b>		H=210
Mounting, axle beam	All Models		<b>F8-5907</b>		H=31; d1=18; d2=19; D1=65; D2=56
Rubber Buffer, suspension	1.4, 1.6, 1.8 T, 1.9 TDI, 2.0, 2.5	for OE: G18, G59	<b>F8-5996</b>		H=63

<b>AK-735095</b>	<b>AK-735410</b>	<b>F5-1004</b>	<b>F5-1076</b>	<b>F5-1085</b>	<b>F8-3039</b>	<b>F8-4067</b>
Ref.Nr.: 1J0512131B	Ref.Nr.: 1J0412303	Ref.Nr.: 038903119T	Ref.Nr.: 07K903119C	Ref.Nr.: 045903119A	Ref.Nr.: 357412249A	Ref.Nr.: 1J0412331B
<b>F8-5215</b>	<b>F8-5303</b>	<b>F8-5380</b>	<b>F8-5381</b>	<b>F8-5382</b>	<b>F8-5384</b>	<b>F8-5386</b>
Ref.Nr.: 1J0411314B	Ref.Nr.: 7H0407183	Ref.Nr.: 1J0513353G	Ref.Nr.: 1J0512149B	Ref.Nr.: 1J0411327	Ref.Nr.: 1J0199555AL	Ref.Nr.: 1J0199555AJ
<b>F8-5388</b>	<b>F8-5390</b>	<b>F8-5580</b>	<b>F8-5650</b>	<b>F8-5683</b>	<b>F8-5907</b>	<b>F8-5996</b>
Ref.Nr.: 1J0199262BK	Ref.Nr.: 1J0199262BE	Ref.Nr.: 1J0412341	Ref.Nr.: 06A105243E	Ref.Nr.: 357413175A	Ref.Nr.: 1J0199429	Ref.Nr.: 1H0412303B

Article Description



Article Nr.

Fitting Position



**NEW BEETLE Convertible (1Y7)** 09/2002 → 10/2010

Rubber Buffer, suspension	1.4, 1.6, 1.8 T, 1.9 TDI, 2.0, 2.5	for OE: G50, G54;	<b>F8-5996</b>		H=63
Rubber Buffer, suspension	1.4, 1.6, 1.8 T, 1.9 TDI, 2.0, 2.5	for OE: G74; for vehicles with sports package	<b>F8-5996</b>		H=63
Rubber Buffer, suspension	1.4, 1.6, 1.8 T, 1.9 TDI, 2.0		<b>F8-6012</b>		H=143
Top Strut Mounting	1.4, 1.6, 1.8 T, 1.9 TDI, 2.0, 2.5	2006→	<b>F8-6040</b>		
Top Strut Mounting	1.4, 1.6, 1.8 T, 1.9 TDI, 2.0, 2.5	for OE: UB1, UB9, UC2, UC4; →2005	<b>F8-6040</b>		
Rubber Buffer, suspension	1.4, 1.6, 1.8 T, 1.9 TDI, 2.0, 2.5	for OE: G16, G49;	<b>F8-6041</b>		H=53
Rubber Buffer, suspension	1.4, 1.6, 1.8 T, 1.9 TDI, 2.0, 2.5	for OE: G73, G87;	<b>F8-6041</b>		H=53
Rubber Buffer, suspension	1.4, 1.6, 1.8 T, 1.9 TDI, 2.0, 2.5	for OE: G80	<b>F8-6041</b>		H=53
Protective Cap/Bellow, shock absorber	All Models	for OE: UB9, UC2, UC4	<b>F8-6044</b>		H=160
Mounting, axle beam	1.4, 1.6, 1.9 TDI, 2.0		<b>F8-6076</b>		d=12; L=90; D=69
Repair Set, axle beam	1.4, 1.6, 1.9 TDI		<b>F8-6077</b>		H=90; D=69
Repair Set, axle beam	2.0		<b>F8-6077</b>		H=90; D=69
Top Strut Mounting	All Models		<b>F8-6280</b>		H=53; d=26; D=82
Belt Pulley, crankshaft	1.9 TDI	Number of Ribs: 5; Parameter: 6PK	<b>F8-6392</b>		H=47; d=30; D=143
Bracket, stabilizer mounting	1.4, 1.6, 1.8 T, 1.9 TDI, 2.5		<b>F8-6579</b>		
Bracket, stabilizer mounting	2.0		<b>F8-6579</b>		
Top Strut Mounting	All Models	for OE: 1J0412319C	<b>F8-7133</b>		
Stabiliser Mounting	1.6, 1.8 T, 2.0		<b>F8-7936</b>		
Control Arm-/Trailing Arm Bush	1.4, 1.6, 1.8 T, 1.9 TDI		<b>F8-7978</b>		
Engine Mounting	1.4		<b>F8-8198</b>		

**BEETLE (5C1)** 04/2011 →

Alternator Freewheel Clutch	1.6 TDI, 2.0 TDI		<b>F5-1004</b>		
Alternator Freewheel Clutch	2.0 TSI		<b>F5-1044</b>		
Alternator Freewheel Clutch	1.2 TSI, 1.4 TSI		<b>F5-1064</b>		
Control Arm-/Trailing Arm Bush	1.2 TSI, 1.4 TSI, 1.6 TDI, 2.0 TDI, 2.0 TSI		<b>F8-5633</b>		
Rubber Buffer, suspension	1.2 TSI	for OE: G12;	<b>F8-6041</b>		H=53
Protective Cap/Bellow, shock absorber	1.2 TSI, 1.4 TSI, 1.6 TDI, 2.0 TDI, 2.0 TSI, 2.5	for OE: 1JA, UA1, UB4, UB8;	<b>F8-6044</b>		H=160
Protective Cap/Bellow, shock absorber	1.2 TSI, 1.4 TSI, 1.6 TDI, 2.0 TDI, 2.0 TSI, 2.5	for OE: UB1, UB2, UB5, UB9;	<b>F8-6044</b>		H=160
Top Strut Mounting	1.2 TSI, 1.4 TSI, 1.6 TDI, 2.0 TDI, 2.0 TSI, 2.5		<b>F8-6284</b>		
Top Strut Mounting	1.2 TSI, 1.4 TSI, 1.6 TDI, 2.0 TDI, 2.0 TSI, 2.5	for OE: 0N4	<b>F8-6348</b>		
Anti-Friction Bearing	1.2 TSI, 1.4 TSI, 1.6 TDI, 2.0 TDI, 2.0 TSI, 2.5		<b>F8-6569</b>		



**Article Description****Article Nr.****Fitting Position****BEETLE (5C1)** 04/2011 →

Top Strut Mounting	1.2 TSI, 1.4 TSI, 1.6 TDI, 2.0 TDI, 2.0 TSI, 2.5		<b>F8-6570</b>		
Belt Pulley, crankshaft	1.6 TDI	Number of Ribs: 5; Parameter: 6PK	<b>F8-6572</b>		
Rubber Buffer, suspension	1.2 TSI, 1.4 TSI, 1.6 TDI, 2.0 TDI, 2.0 TSI, 2.5	for OE: 2UA, 2UD, G17, G22, G42;	<b>F8-7131</b>		H=70
Protective Cap/Bellow, shock absorber	1.2 TSI, 1.4 TSI, 1.6 TDI, 2.0 TDI, 2.0 TSI, 2.5		<b>F8-7132</b>		H=190
Rubber Buffer, suspension	1.2 TSI, 1.4 TSI, 1.6 TDI, 2.0 TDI, 2.0 TSI, 2.5	for OE: 0N4, UB7, UC2;	<b>F8-7140</b>		H=133
Rubber Buffer, suspension	1.2 TSI, 1.4 TSI, 2.0 TDI, 2.0 TSI, 2.5	for OE: 0N4; Shape Round	<b>F8-7601</b>		H=118
Protective Cap/Bellow, shock absorber	1.2 TSI, 1.4 TSI, 1.6 TDI, 2.0 TDI, 2.0 TSI, 2.5		<b>F8-7640</b>		H=176
Rubber Buffer, suspension	1.2 TSI, 1.4 TSI, 1.6 TDI, 2.0 TDI, 2.0 TSI, 2.5	for OE: 2UC, G17, G22, G57;	<b>F8-7697</b>		H=55
Rubber Buffer, suspension	1.2 TSI, 1.4 TSI, 1.6 TDI, 2.0 TDI, 2.0 TSI, 2.5	for OE: 2UA, 2UC, G45	<b>F8-7809</b>		H=55
Control Arm-/Trailing Arm Bush	1.2 TSI, 1.4 TSI, 2.0 TDI, 2.0 TSI, 2.5	ch. 16-C-500001→	<b>F8-7856</b>		H=50; d=13.2; D=65
Control Arm-/Trailing Arm Bush	1.6 TDI, 2.0 TSI		<b>F8-7856</b>		H=50; d=13.2; D=65
Belt Pulley, crankshaft	2.0 TSI	Number of Ribs: 5; Parameter: 6PK	<b>F8-7880</b>		D=143
Control Arm-/Trailing Arm Bush	1.2 TSI, 1.4 TSI, 1.6 TDI, 2.0 TDI, 2.0 TSI		<b>F8-7909</b>		

**BEETLE Convertible (5C7)** 12/2011 →

Alternator Freewheel Clutch	2.0 TSI		<b>F5-1044</b>		
Alternator Freewheel Clutch	1.2 TSI, 1.4 TSI		<b>F5-1064</b>		
Protective Cap/Bellow, shock absorber	1.2 TSI, 1.4 TSI, 1.6 TDI, 2.0 TDI, 2.0 TSI	for OE: 1JA, UA1, UB4, UB8;	<b>F8-6044</b>		H=160
Protective Cap/Bellow, shock absorber	1.2 TSI, 1.4 TSI, 1.6 TDI, 2.0 TDI, 2.0 TSI	for OE: UB1, UB2, UB5;	<b>F8-6044</b>		H=160
Top Strut Mounting	1.2 TSI, 1.4 TSI, 1.6 TDI, 2.0 TDI, 2.0 TSI		<b>F8-6284</b>		
Top Strut Mounting	1.2 TSI, 1.4 TSI, 1.6 TDI, 2.0 TDI, 2.0 TSI	for OE: 0N4	<b>F8-6348</b>		
Anti-Friction Bearing	1.2 TSI, 1.4 TSI, 1.6 TDI, 2.0 TDI, 2.0 TSI		<b>F8-6569</b>		
Top Strut Mounting	1.2 TSI, 1.4 TSI, 1.6 TDI, 2.0 TDI, 2.0 TSI		<b>F8-6570</b>		
Rubber Buffer, suspension	1.2 TSI, 1.4 TSI, 1.6 TDI, 2.0 TDI, 2.0 TSI	for OE: 2UA, 2UD, G17, G22, G42, G49	<b>F8-7131</b>		H=70
Protective Cap/Bellow, shock absorber	1.2 TSI, 1.4 TSI, 1.6 TDI, 2.0 TDI, 2.0 TSI		<b>F8-7132</b>		H=190
Rubber Buffer, suspension	1.2 TSI, 1.4 TSI, 1.6 TDI, 2.0 TDI, 2.0 TSI	for OE: 0N4, UB7, UC2;	<b>F8-7140</b>		H=133
Protective Cap/Bellow, shock absorber	1.2 TSI, 1.4 TSI, 1.6 TDI, 2.0 TDI, 2.0 TSI		<b>F8-7640</b>		H=176
Rubber Buffer, suspension	1.2 TSI, 1.4 TSI, 1.6 TDI, 2.0 TDI, 2.0 TSI	for OE: 2UC+G22, G17, G49, G57;	<b>F8-7697</b>		H=55
Control Arm-/Trailing Arm Bush	1.2 TSI, 1.4 TSI, 1.6 TDI, 2.0 TDI, 2.0 TSI		<b>F8-7856</b>		H=50; d=13.2; D=65
Belt Pulley, crankshaft	2.0 TSI	Number of Ribs: 5; Parameter: 6PK	<b>F8-7880</b>		D=143

<b>F5-1044</b>	<b>F5-1064</b>	<b>F8-6044</b>	<b>F8-6284</b>	<b>F8-6348</b>	<b>F8-6569</b>	<b>F8-6570</b>
Ref.Nr.: 06B903119B	Ref.Nr.: 03C903119D	Ref.Nr.: 3C0513425	Ref.Nr.: 6N0412249C	Ref.Nr.: 1K0513353G	Ref.Nr.: 6N0412249C	Ref.Nr.: 1K0412331C
<b>F8-6572</b>	<b>F8-7131</b>	<b>F8-7132</b>	<b>F8-7140</b>	<b>F8-7601</b>	<b>F8-7640</b>	<b>F8-7697</b>
Ref.Nr.: 038105243L	Ref.Nr.: 1K0412303B	Ref.Nr.: 6N0413175A	Ref.Nr.: 3C0511359	Ref.Nr.: 1K0511353N	Ref.Nr.: 1K0513425A	Ref.Nr.: 1K0412303F
<b>F8-7809</b>	<b>F8-7856</b>	<b>F8-7880</b>	<b>F8-7909</b>			
Ref.Nr.: 1K0412303E	Ref.Nr.: 5C0407183A	Ref.Nr.: 06H105243F	Ref.Nr.: 1K0505553 A			

**Article Description**

**Article Nr.**
**Fitting Position**

<b>BORA (1J2)</b>		<b>10/1998 → 05/2005</b>	
Dust Cover Kit, shock absorber	1.4 16V, 1.6, 1.6 16V, 1.6 FSI, 1.8, 1.8 4motion, 1.8 T, 1.8 T 4motion, 1.9 SDI, 1.9 TDI, 1.9 TDI 4motion, 2.0, 2.0 4motion, 2.3 V5, 2.3 V5 4motion, 2.8 V6 4motion		AK-735039
Dust Cover Kit, shock absorber	1.4 16V, 1.6, 1.6 16V, 1.6 FSI, 1.8, 1.8 T, 1.9 SDI, 1.9 TDI, 2.0, 2.3 V5		AK-735095
Dust Cover Kit, shock absorber	1.6		AK-735095
Dust Cover Kit, shock absorber	All Models	ST	AK-735410
Alternator Freewheel Clutch	1.6, 1.8 T, 1.8 T 4motion, 1.9 SDI, 1.9 TDI, 1.9 TDI 4motion, 2.0, 2.0 4motion, 2.3 V5, 2.3 V5 4motion, 2.8 V6 4motion		F5-1004
Anti-Friction Bearing	All Models		F8-3039
Top Strut Mounting	All Models		F8-4067
Bellow Set, steering	1.4 16V, 1.6, 1.6 16V, 1.8, 1.8 4motion, 1.9 SDI, 1.9 TDI, 1.9 TDI 4motion, 2.0, 2.3 V5, 2.3 V5 4motion, 2.8 V6 4motion	for OE: 1J0422831	F8-4074
Stabiliser Mounting	1.4 16V, 1.6, 1.6 16V, 1.6 FSI, 1.8 T, 1.9 SDI, 1.9 TDI, 2.0, 2.3 V5	ch.→1J-X-999000; only in connection with: F8-6579; Stabi. Diam. [mm]= 19	F8-5215
Stabiliser Mounting	1.6	ch.→1J-X-999000;  AVU, BFQ; only in connection with: F8-6579; Stabi. Diam. [mm]= 19	F8-5215
Stabiliser Mounting	1.8	ch.→1J-X-999000;  AGN; only in connection with: F8-6579; Stabi. Diam. [mm]= 19	F8-5215
Stabiliser Mounting	1.8 T	ch.→1J-X-999000;  AGU, ARX, AUM; only in connection with: F8-6579; Stabi. Diam. [mm]= 19	F8-5215
Stabiliser Mounting	1.9 TDI 4motion, 2.3 V5 4motion	only in connection with: F8-6579; Stabi. Diam. [mm]= 19	F8-5215
Stabiliser Mounting	2.0 4motion	AZJ; only in connection with: F8-6579; Stabi. Diam. [mm]= 19	F8-5215
Stabiliser Mounting	2.8 V6 4motion	BDE; only in connection with: F8-6579; Stabi. Diam. [mm]= 19	F8-5215
Stabiliser Mounting	1.4 16V, 1.8 4motion, 1.9 TDI 4motion, 2.8 V6 4motion	ch.1J-Y-99000→; only in connection with: F8-6579; Stabi. Diam. [mm]= 23;	F8-5220
Stabiliser Mounting	1.6, 1.8, 1.9 SDI, 1.9 TDI, 2.0, 2.3 V5, 2.3 V5 4motion	ch.1J-Y-99000→; 01/1999 →; only in connection with: F8-6579; Stabi. Diam. [mm]= 23;	F8-5220
Stabiliser Mounting	1.4 16V, 1.6, 1.6 16V, 1.6 FSI, 1.8, 1.8 4motion, 1.8 T, 1.9 SDI, 1.9 TDI, 1.9 TDI 4motion, 2.0, 2.0 4motion, 2.3 V5, 2.3 V5 4motion, 2.8 V6 4motion	ch.→1J-Y-990000; only in connection with: F8-6579; Stabi. Diam. [mm]= 21	F8-5221
Mounting, axle beam	1.4 16V, 1.6, 1.6 16V, 1.6 FSI, 1.8, 1.8 4motion, 1.8 T, 1.9 SDI, 1.9 TDI, 1.9 TDI 4motion, 2.0, 2.0 4motion, 2.3 V5, 2.3 V5 4motion, 2.8 V6 4motion		F8-5340
Top Strut Mounting	1.4 16V, 1.6, 1.6 16V, 1.6 FSI, 1.8, 1.8 T, 1.9 SDI, 1.9 TDI, 2.0, 2.3 V5	ch.→1J-Y-530000	F8-5380





**Article Description****Article Nr.****Fitting Position**

<b>BORA (1J2)</b>		<b>10/1998 → 05/2005</b>	
Top Strut Mounting	1.6		<b>F8-5380</b>
Rubber Buffer, suspension	1.4 16V, 1.6, 1.6 16V, 1.6 FSI, 1.8, 1.8 T, 1.9 SDI, 1.9 TDI, 2.0, 2.3 V5		<b>F8-5381</b> H=37; D=76
Stabiliser Mounting	1.4 16V, 1.6, 1.6 16V, 1.6 FSI, 1.8, 1.8 4motion, 1.8 T, 1.9 SDI, 1.9 TDI, 1.9 TDI 4motion, 2.0, 2.0 4motion, 2.3 V5, 2.3 V5 4motion, 2.8 V6 4motion		<b>F8-5382</b> D=14
Engine Mounting	1.4 16V, 1.6, 1.6 16V, 1.8, 2.0, 2.3 V5		<b>F8-5383</b>
Engine Mounting	1.9 SDI, 1.9 TDI		<b>F8-5384</b>
Mounting, manual transmission	1.4 16V, 1.6		<b>F8-5385</b>
Mounting, manual transmission	1.6	AVU;	<b>F8-5385</b>
Mounting, manual transmission	1.6 16V		<b>F8-5385</b>
Engine Mounting	1.4 16V, 1.6, 1.6 16V		<b>F8-5386</b>
Engine Mounting	1.8 T		<b>F8-5386</b>
Engine Mounting	1.8, 1.9 TDI, 2.0		<b>F8-5386</b>
Mounting, automatic transmission	1.8	AGN;	<b>F8-5387</b>
Mounting, automatic transmission	1.8 4motion, 1.9 TDI 4motion, 2.0 4motion		<b>F8-5387</b>
Mounting, automatic transmission	1.8 T	01/2002 →;  AGU;  4-speed	<b>F8-5387</b>
Mounting, automatic transmission	1.9 TDI	4-speed	<b>F8-5387</b>
Mounting, automatic transmission	1.9 TDI	AHF;  4-speed	<b>F8-5387</b>
Mounting, automatic transmission	1.9 TDI	AJM;  5-speed	<b>F8-5387</b>
Mounting, automatic transmission	2.0	01/2002 →;  AQY;  4-speed	<b>F8-5387</b>
Mounting, automatic transmission	2.3 V5	5-speed	<b>F8-5387</b>
Engine Mounting	1.4 16V	05/2001 →;  AHW, AKQ, AXP, BCA;	<b>F8-5388</b>
Engine Mounting	1.6 16V, 1.6 FSI		<b>F8-5388</b>
Engine Mounting	1.4 16V	APE, AXP	<b>F8-5390</b>
Engine Mounting	1.6		<b>F8-5390</b>
Engine Mounting	1.6, 1.8, 1.8 T, 1.9 SDI, 1.9 TDI, 2.0		<b>F8-5404</b>
Spring Cap	All Models		<b>F8-5580</b> D=92
Belt Pulley, crankshaft	1.8 4motion, 1.8 T, 2.0, 2.0 4motion		<b>F8-5650</b>
Protective Cap/Bellow, shock absorber	All Models		<b>F8-5683</b> H=210

<b>F8-5380</b>	<b>F8-5381</b>	<b>F8-5382</b>	<b>F8-5383</b>	<b>F8-5384</b>	<b>F8-5385</b>	<b>F8-5386</b>
Ref.Nr.: 1J0513353G	Ref.Nr.: 1J0512149B	Ref.Nr.: 1J0411327	Ref.Nr.: 1J0199851AA	Ref.Nr.: 1J0199555AL	Ref.Nr.: 1J0199555AK	Ref.Nr.: 1J0199555AJ
<b>F8-5387</b>	<b>F8-5388</b>	<b>F8-5390</b>	<b>F8-5404</b>	<b>F8-5580</b>	<b>F8-5650</b>	<b>F8-5683</b>
Ref.Nr.: 1J0199555AH	Ref.Nr.: 1J0199262BK	Ref.Nr.: 1J0199262BE	Ref.Nr.: 1J0199262BF	Ref.Nr.: 1J0412341	Ref.Nr.: 06A105243E	Ref.Nr.: 357413175A
<b>F8-5907</b>						
Ref.Nr.: 1J0199429						

Article Description



Article Nr.

Fitting Position



<b>BORA (1J2)</b>		<b>10/1998 → 05/2005</b>	
Mounting, axle beam	All Models		<b>F8-5907</b>
Rubber Buffer, suspension	1.4 16V, 1.6, 1.6 16V, 1.8, 1.8 4motion, 1.8 T, 1.9 SDI, 1.9 TDI, 1.9 TDI 4motion, 2.0	<b>ST</b>	<b>F8-5996</b>
Rubber Buffer, suspension	1.4 16V, 1.6, 1.6 16V, 1.8, 1.8 T, 1.9 SDI, 1.9 TDI, 2.0, 2.3 V5, 2.8 V6 4motion	<b>SP</b>	<b>F8-6007</b>
Rubber Buffer, suspension	1.4 16V, 1.6, 1.6 16V, 1.6 FSI, 1.8, 1.8 T, 1.9 SDI, 1.9 TDI, 1.9 TDI 4motion, 2.0, 2.3 V5, 2.8 V6 4motion	<b>△</b>	<b>F8-6012</b>
Rubber Buffer, suspension	1.4 16V, 1.6, 1.6 16V, 1.8, 1.8 T, 1.9 SDI, 1.9 TDI, 2.0, 2.3 V5, 2.8 V6 4motion		<b>F8-6013</b>
Top Strut Mounting	1.4 16V, 1.6, 1.6 16V, 1.6 FSI, 1.8, 1.8 T, 1.9 SDI, 1.9 TDI, 2.0, 2.3 V5	ch.1JY530001→	<b>F8-6040</b>
Rubber Buffer, suspension	1.4 16V, 1.6, 1.6 16V, 1.6 FSI, 1.8, 1.8 T, 1.9 SDI, 1.9 TDI, 2.0, 2.3 V5	<b>SP</b>	<b>F8-6041</b>
Rubber Buffer, suspension	1.8 4motion, 1.9 TDI 4motion	for OE: 1GV, G75, G84; <b>SP</b>	<b>F8-6041</b>
Rubber Buffer, suspension	1.8 T 4motion	for OE: 1GV; <b>SP</b>	<b>F8-6041</b>
Rubber Buffer, suspension	1.9 TDI 4motion, 2.0 4motion	for OE: 1GD, G45, G46, G47, G72, G76, G81, G84, G88; <b>SP</b>	<b>F8-6041</b>
Rubber Buffer, suspension	1.9 TDI 4motion, 2.0 4motion, 2.3 V5 4motion, 2.8 V6 4motion	for OE: 1GD, G45, G46, G47, G58, G72, G75, G76, G81, G84, G88; <b>SP</b>	<b>F8-6041</b>
Rubber Buffer, suspension	2.3 V5 4motion	ch.1J-1-000001→; for OE: G46, G47	<b>F8-6041</b>
Rubber Buffer, suspension	2.3 V5 4motion	ch.1J-Y-360001→; ch.→1J-Y-800000; for OE: 1GU	<b>F8-6041</b>
Rubber Buffer, suspension	2.8 V6 4motion	ch.→1J-Y-800000; for OE: 1GT	<b>F8-6041</b>
Rubber Buffer, suspension	2.8 V6 4motion	ch.1J-1-000001→; for OE: G88	<b>F8-6041</b>
Rubber Buffer, suspension	2.8 V6 4motion	for OE: G88; <b>SP</b>	<b>F8-6041</b>
Protective Cap/Bellow, shock absorber	1.4 16V, 1.6, 1.6 16V, 1.6 FSI, 1.8, 1.8 T, 1.9 SDI, 1.9 TDI, 2.0, 2.3 V5	<b>△</b>	<b>F8-6044</b>
Protective Cap/Bellow, shock absorber	1.8 T	for OE: 1JB; <b>△</b>	<b>F8-6044</b>
Protective Cap/Bellow, shock absorber	1.4 16V, 1.6, 1.6 16V, 1.6 FSI, 1.8, 1.8 T, 1.9 SDI, 1.9 TDI, 2.0, 2.3 V5		<b>F8-6045</b>
Mounting, axle beam	1.4 16V, 1.6, 1.6 16V, 1.6 FSI, 1.8, 1.8 T, 1.9 SDI, 1.9 TDI, 2.0, 2.3 V5		<b>F8-6076</b>
Repair Set, axle beam	1.4 16V, 1.6, 1.6 16V, 1.6 FSI, 1.8 T, 1.9 SDI, 1.9 TDI, 2.3 V5		<b>F8-6077</b>
Repair Set, axle beam	1.6	BFQ	<b>F8-6077</b>
Repair Set, axle beam	1.8	AGN	<b>F8-6077</b>
Repair Set, axle beam	1.8 T	ARX	<b>F8-6077</b>
Repair Set, axle beam	2.0	AZJ	<b>F8-6077</b>
Top Strut Mounting	All Models		<b>F8-6280</b>

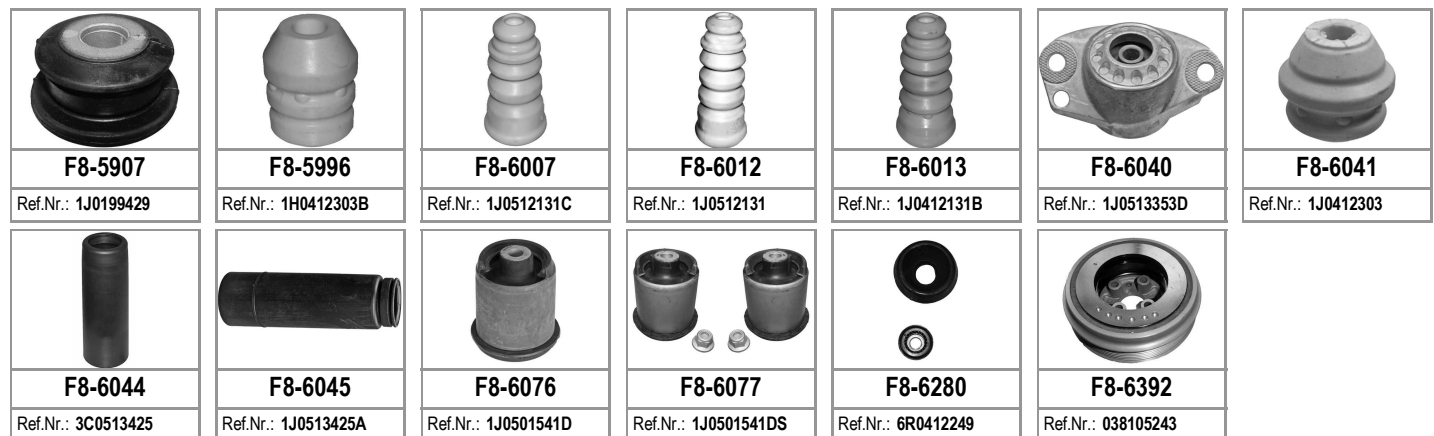

**Article Description****Article Nr.****Fitting Position****BORA (1J2) 10/1998 → 05/2005**

Belt Pulley, crankshaft	1.9 TDI, 1.9 TDI 4motion	05/2001 →; Engine →435000; Number of Ribs: 5; Parameter: 6PK	<b>F8-6392</b>		H=47; d=30; D=143
Belt Pulley, crankshaft	1.9 TDI, 1.9 TDI 4motion	Number of Ribs: 5; Parameter: 6PK	<b>F8-6392</b>		H=47; d=30; D=143
Belt Pulley, crankshaft	1.9 SDI	ch.1J-3D016001, 1J-3W350001→;  AQM; Number of Ribs: 5; Parameter: 6PK	<b>F8-6396</b>		H=41.6; d=30; Mounting points diam.[mm]=7, 8.6; D=139.7
Belt Pulley, crankshaft	1.9 TDI, 1.9 TDI 4motion	ch.1J-3D016001, 1J-3W350001→; Number of Ribs: 5; Parameter: 6PK	<b>F8-6396</b>		H=41.6; d=30; Mounting points diam.[mm]=7, 8.6; D=139.7
Bracket, stabilizer mounting	1.4 16V, 1.6, 1.6 16V, 1.6 FSI, 1.8 4motion, 1.8 T, 1.8 T 4motion, 1.9 SDI, 1.9 TDI, 1.9 TDI 4motion, 2.0, 2.0 4motion, 2.3 V5, 2.3 V5 4motion, 2.8 V6 4motion		<b>F8-6579</b>		
Bracket, stabilizer mounting	1.6	AVU, BFQ	<b>F8-6579</b>		
Bracket, stabilizer mounting	1.8	AGN	<b>F8-6579</b>		
Bracket, stabilizer mounting	1.8 T	AGU, ARX, AUM	<b>F8-6579</b>		
Engine Mounting	1.9 TDI, 1.9 TDI 4motion		<b>F8-6960</b>		
Mounting, axle bracket	1.8 4motion, 1.8 T 4motion, 1.9 TDI 4motion, 2.0 4motion, 2.3 V5 4motion, 2.8 V6 4motion		<b>F8-7046</b>		H=55; d=16; D=52
Top Strut Mounting	All Models	for OE: 1J0412319C	<b>F8-7133</b>		
Belt Pulley, crankshaft	1.9 SDI, 1.9 TDI, 1.9 TDI 4motion	ch.→1J-3D016000, 1J-3W350000	<b>F8-7864</b>		
Stabiliser Mounting	1.8 4motion, 1.9 TDI 4motion, 2.0 4motion, 2.3 V5 4motion, 2.8 V6 4motion	ch.1J-Y-000 001→; ch.→1J-4-220000; for OE: 0AR	<b>F8-7901</b>		
Stabiliser Mounting	1.8 4motion, 1.9 TDI 4motion, 2.0 4motion, 2.3 V5 4motion, 2.8 V6 4motion		<b>F8-7927</b>		d=18
Stabiliser Mounting	1.4 16V, 1.6, 1.8, 1.9 TDI, 2.0		<b>F8-7936</b>		
Control Arm-/Trailing Arm Bush	All Models		<b>F8-7978</b>		
Engine Mounting	1.4 16V		<b>F8-8198</b>		
Control Arm-/Trailing Arm Bush	1.4 16V, 1.6, 1.6 16V, 1.6 FSI, 1.8, 1.8 4motion, 1.8 T, 1.9 SDI, 1.9 TDI, 1.9 TDI 4motion, 2.0, 2.0 4motion, 2.3 V5, 2.3 V5 4motion, 2.8 V6 4motion		<b>G9-648</b>		H=54; d=12; D1=33; D2=36
Control Arm-/Trailing Arm Bush	1.4 16V, 1.6, 1.6 16V, 1.6 FSI, 1.8, 1.8 4motion, 1.8 T, 1.9 SDI, 1.9 TDI, 1.9 TDI 4motion, 2.0, 2.0 4motion, 2.3 V5, 2.3 V5 4motion, 2.8 V6 4motion		<b>G9-649</b>		H1=25; H2=41; d=13; D=60
Bellow, steering	All Models	with clamps;	<b>LM-10020S</b>		d1=16; d2=48; L [mm]=179
Bellow Set, drive shaft	1.9 TDI	ATD; with clamps;	<b>MK-810160</b>		L=116
Bellow Set, drive shaft	2.3 V5	with clamps;	<b>MK-810160</b>		L=116

**BORA Estate (1J6) 05/1999 → 05/2005**

Dust Cover Kit, shock absorber	1.4 16V, 1.6, 1.6 16V, 1.6 FSI, 1.8 4motion, 1.8 T, 1.9 TDI, 1.9 TDI 4motion, 2.0, 2.0 4motion, 2.3 V5, 2.3 V5 4motion, 2.8 V6 4motion		<b>AK-735039</b>		
Dust Cover Kit, shock absorber	1.4 16V, 1.6, 1.6 16V, 1.6 FSI, 1.8 T, 1.9 TDI, 2.0, 2.3 V5		<b>AK-735095</b>		

<b>AK-735039</b>	<b>AK-735095</b>	<b>AK-735410</b>	<b>F8-6392</b>	<b>F8-6396</b>	<b>F8-6579</b>	<b>F8-6960</b>
Ref.Nr.: 357413175A	Ref.Nr.: 1J0512131B	Ref.Nr.: 1J0412303	Ref.Nr.: 038105243	Ref.Nr.: 03G105243	Ref.Nr.: 1J0 411 336 C	Ref.Nr.: 1J0199262P
<b>F8-7046</b>	<b>F8-7133</b>	<b>F8-7864</b>	<b>F8-7901</b>	<b>F8-7927</b>	<b>F8-7936</b>	<b>F8-7978</b>
Ref.Nr.: 1J0505145B	Ref.Nr.: 1J0412319C	Ref.Nr.: 038 105 243	Ref.Nr.: 1J0411314P	Ref.Nr.: 1J0411314AC	Ref.Nr.: 1J0411327A	Ref.Nr.: 357407182F
<b>F8-8198</b>	<b>G9-648</b>	<b>G9-649</b>	<b>LM-10020S</b>	<b>MK-810160</b>		
Ref.Nr.: 1J0199555BD	Ref.Nr.: 357407182	Ref.Nr.: 1J0407181	Ref.Nr.: 1J0422831B	Ref.Nr.: 3D0 498 201		

Article Description



Article Nr.

Fitting Position



**BORA Estate (1J6)**

05/1999 → 05/2005

Dust Cover Kit, shock absorber	1.4 16V, 1.6, 1.6 16V, 1.6 FSI, 1.8 4motion, 1.8 T, 1.9 TDI, 1.9 TDI 4motion, 2.0, 2.0 4motion, 2.3 V5, 2.3 V5 4motion, 2.8 V6 4motion, 2.8 VR6	<b>ST</b>	<b>AK-735410</b>		H=210
Alternator Freewheel Clutch	1.6, 1.8 T, 1.9 TDI, 1.9 TDI 4motion, 2.0, 2.0 4motion, 2.3 V5, 2.3 V5 4motion, 2.8 V6 4motion, 2.8 VR6		<b>F5-1004</b>		
Anti-Friction Bearing	All Models		<b>F8-3039</b>		H=14; d1=14; D=45
Top Strut Mounting	1.4 16V, 1.6, 1.6 16V, 1.6 FSI, 1.8 4motion, 1.8 T, 1.9 TDI, 1.9 TDI 4motion, 2.0, 2.0 4motion, 2.3 V5, 2.3 V5 4motion, 2.8 V6 4motion		<b>F8-4067</b>		H=53; d=26; D=82
Bellow Set, steering	1.6, 1.6 16V, 1.8 4motion, 1.9 TDI, 1.9 TDI 4motion, 2.0, 2.3 V5, 2.3 V5 4motion, 2.8 V6 4motion	for OE: 1J0422831	<b>F8-4074</b>		H=125; D1=34; D2=39
Stabiliser Mounting	1.4 16V, 1.6 FSI, 1.8 T, 1.9 TDI, 1.9 TDI 4motion, 2.3 V5, 2.3 V5 4motion	only in connection with: F8-6579; Stabi. Diam. [mm]= 19	<b>F8-5215</b>		d=17
Stabiliser Mounting	1.6	AEH, AKL; only in connection with: F8-6579; Stabi. Diam. [mm]= 19	<b>F8-5215</b>		d=17
Stabiliser Mounting	1.6	BFC; only in connection with: F8-6579; Stabi. Diam. [mm]= 19	<b>F8-5215</b>		d=17
Stabiliser Mounting	1.6 16V	BCB; only in connection with: F8-6579; Stabi. Diam. [mm]= 19	<b>F8-5215</b>		d=17
Stabiliser Mounting	1.8 T	AGU, AUM; only in connection with: F8-6579; Stabi. Diam. [mm]= 19	<b>F8-5215</b>		d=17
Stabiliser Mounting	1.9 TDI	ASV; only in connection with: F8-6579; Stabi. Diam. [mm]= 19	<b>F8-5215</b>		d=17
Stabiliser Mounting	2.0, 2.0 4motion	AZJ; only in connection with: F8-6579; Stabi. Diam. [mm]= 19	<b>F8-5215</b>		d=17
Stabiliser Mounting	2.8 V6 4motion	BDE; only in connection with: F8-6579; Stabi. Diam. [mm]= 19	<b>F8-5215</b>		d=17
Stabiliser Mounting	1.9 TDI, 2.0	ch. 1J-Y-99000→; only in connection with: F8-6579; Stabi. Diam. [mm]= 23;	<b>F8-5220</b>		d=21
Stabiliser Mounting	1.6, 1.6 16V, 1.6 FSI, 1.8 4motion, 1.8 T, 1.9 TDI, 1.9 TDI 4motion, 2.0, 2.0 4motion, 2.3 V5, 2.3 V5 4motion, 2.8 V6 4motion	ch.→1J-Y-990000; only in connection with: F8-6579; Stabi. Diam. [mm]= 21	<b>F8-5221</b>		d=19; D=20.7
Mounting, axle beam	1.6, 1.6 16V, 1.6 FSI, 1.8 4motion, 1.8 T, 1.9 TDI, 1.9 TDI 4motion, 2.0, 2.0 4motion, 2.3 V5, 2.3 V5 4motion, 2.8 V6 4motion		<b>F8-5340</b>		H=90; d=12; D=72
Top Strut Mounting	1.4 16V, 1.6, 1.6 16V, 1.6 FSI, 1.8 T, 1.9 TDI, 2.0, 2.3 V5		<b>F8-5380</b>		
Rubber Buffer, suspension	1.4 16V, 1.6, 1.6 16V, 1.6 FSI, 1.8 T, 1.9 TDI, 2.0, 2.3 V5		<b>F8-5381</b>		H=37; D=76
Stabiliser Mounting	1.4 16V, 1.6, 1.6 16V, 1.6 FSI, 1.8 4motion, 1.8 T, 1.9 TDI, 1.9 TDI 4motion, 2.0, 2.0 4motion, 2.3 V5, 2.3 V5 4motion, 2.8 V6 4motion		<b>F8-5382</b>		D=14
Engine Mounting	1.6, 1.6 16V, 1.8 4motion, 2.0, 2.3 V5		<b>F8-5383</b>		
Engine Mounting	1.9 TDI		<b>F8-5384</b>		

<b>AK-735410</b>	<b>F5-1004</b>	<b>F8-3039</b>	<b>F8-4067</b>	<b>F8-4074</b>	<b>F8-5215</b>	<b>F8-5220</b>
Ref.Nr.: 1J0412303	Ref.Nr.: 038903119T	Ref.Nr.: 357412249A	Ref.Nr.: 1J0412331B	Ref.Nr.: 171419832A	Ref.Nr.: 1J0411314B	Ref.Nr.: 1J0411314G
<b>F8-5221</b>	<b>F8-5340</b>	<b>F8-5380</b>	<b>F8-5381</b>	<b>F8-5382</b>	<b>F8-5383</b>	<b>F8-5384</b>
Ref.Nr.: 1J0411314R	Ref.Nr.: 6R0501541A	Ref.Nr.: 1J0513353G	Ref.Nr.: 1J0512149B	Ref.Nr.: 1J0411327	Ref.Nr.: 1J0199851AA	Ref.Nr.: 1J0199555AL
<b>F8-5385</b>						
Ref.Nr.: 1J0199555AK						

**Article Description****Article Nr.****Fitting Position**

<b>BORA Estate (1J6)</b>			<b>05/1999 → 05/2005</b>		
Mounting, manual transmission	1.4 16V, 1.6 16V		<b>F8-5385</b>		
Mounting, manual transmission	1.6		<b>F8-5385</b>		
Mounting, manual transmission	1.6	AVU;	<b>F8-5385</b>		
Engine Mounting	1.6, 1.6 16V		<b>F8-5386</b>		
Engine Mounting	1.6, 1.8 T		<b>F8-5386</b>		
Engine Mounting	1.8 4motion, 1.9 TDI, 2.0		<b>F8-5386</b>		
Mounting, automatic transmission	1.8 4motion, 2.0 4motion		<b>F8-5387</b>		
Mounting, automatic transmission	1.8 T		<b>F8-5387</b>		
Mounting, automatic transmission	1.9 TDI	,  4-speed	<b>F8-5387</b>		
Mounting, automatic transmission	1.9 TDI	AHF; ,  4-speed	<b>F8-5387</b>		
Mounting, automatic transmission	1.9 TDI	AJM;  5-speed	<b>F8-5387</b>		
Mounting, automatic transmission	2.0	01/2002 →;  APK; ,  4-speed	<b>F8-5387</b>		
Mounting, automatic transmission	2.3 V5	5-speed	<b>F8-5387</b>		
Engine Mounting	1.4 16V, 1.6 16V, 1.6 FSI		<b>F8-5388</b>		
Engine Mounting	1.4 16V, 1.6		<b>F8-5390</b>		
Engine Mounting	1.6, 1.8 4motion, 1.8 T, 1.9 TDI, 1.9 TDI 4motion, 2.0		<b>F8-5404</b>		
Spring Cap	All Models		<b>F8-5580</b>		D=92
Belt Pulley, crankshaft	1.8 4motion, 1.8 T, 2.0, 2.0 4motion		<b>F8-5650</b>		
Protective Cap/Bellow, shock absorber	1.4 16V, 1.6, 1.6 16V, 1.6 FSI, 1.8 4motion, 1.8 T, 1.9 TDI, 1.9 TDI 4motion, 2.0, 2.0 4motion, 2.3 V5, 2.3 V5 4motion, 2.8 V6 4motion, 2.8 VR6		<b>F8-5683</b>		H=210
Mounting, axle beam	1.4 16V, 1.6, 1.6 16V, 1.6 FSI, 1.8 4motion, 1.8 T, 1.9 TDI, 1.9 TDI 4motion, 2.0, 2.0 4motion, 2.3 V5, 2.3 V5 4motion, 2.8 V6 4motion, 2.8 VR6		<b>F8-5907</b>		H=31; d1=18; d2=19; D1=65; D2=56
Rubber Buffer, suspension	1.4 16V, 1.6, 1.6 16V, 1.8 4motion, 1.8 T, 1.9 TDI, 1.9 TDI 4motion, 2.0		<b>F8-5996</b>		H=63
Rubber Buffer, suspension	1.6, 1.6 16V, 1.8 T, 1.9 TDI, 2.0, 2.3 V5, 2.8 V6 4motion		<b>F8-6007</b>		H=116
Rubber Buffer, suspension	1.4 16V, 1.6, 1.6 16V, 1.6 FSI, 1.8 T, 1.9 TDI, 2.0, 2.3 V5, 2.8 V6 4motion		<b>F8-6012</b>		H=143
Rubber Buffer, suspension	1.6, 1.6 16V, 1.8 T, 1.9 TDI, 2.0, 2.3 V5, 2.8 V6 4motion		<b>F8-6013</b>		H=128
Top Strut Mounting	1.4 16V, 1.6, 1.6 16V, 1.6 FSI, 1.8 T, 1.9 TDI, 2.0, 2.3 V5	ch.1JY530001→	<b>F8-6040</b>		

<b>F8-5385</b>	<b>F8-5386</b>	<b>F8-5387</b>	<b>F8-5388</b>	<b>F8-5390</b>	<b>F8-5404</b>	<b>F8-5580</b>
Ref.Nr.: 1J0199555AK	Ref.Nr.: 1J0199555AJ	Ref.Nr.: 1J0199555AH	Ref.Nr.: 1J0199262BK	Ref.Nr.: 1J0199262BE	Ref.Nr.: 1J0199262BF	Ref.Nr.: 1J041234I
<b>F8-5650</b>	<b>F8-5683</b>	<b>F8-5907</b>	<b>F8-5996</b>	<b>F8-6007</b>	<b>F8-6012</b>	<b>F8-6013</b>
Ref.Nr.: 06A105243E	Ref.Nr.: 357413175A	Ref.Nr.: 1J0199429	Ref.Nr.: 1H0412303B	Ref.Nr.: 1J0512131C	Ref.Nr.: 1J0512131	Ref.Nr.: 1J0412131B
<b>F8-6040</b>	<b>F8-6041</b>					
Ref.Nr.: 1J0513353D	Ref.Nr.: 1J0412303					

Article Description



Article Nr.

Fitting Position



**BORA Estate (1J6)**

05/1999 → 05/2005

Rubber Buffer, suspension	1.4 16V, 1.6, 1.6 16V, 1.6 FSI, 1.8 T, 1.9 TDI, 2.0, 2.3 V5	SP	F8-6041		H=53
Rubber Buffer, suspension	1.8 4motion, 1.9 TDI 4motion	for OE: 1GV, G75, G84; SP	F8-6041		H=53
Rubber Buffer, suspension	1.9 TDI 4motion, 2.0 4motion	for OE: 1GD, G45, G46, G47, G72, G76, G81, G84, G88; SP	F8-6041		H=53
Rubber Buffer, suspension	1.9 TDI 4motion, 2.0 4motion, 2.3 V5 4motion, 2.8 V6 4motion	for OE: 1GD, G45, G46, G47, G58, G72, G75, G76, G81, G84, G88; SP	F8-6041		H=53
Rubber Buffer, suspension	2.3 V5 4motion	ch.1J-1-000001→; for OE: G46, G47	F8-6041		H=53
Rubber Buffer, suspension	2.3 V5 4motion	ch.1J-Y-360001→; ch.→1J-Y-800000; for OE: 1GU	F8-6041		H=53
Rubber Buffer, suspension	2.8 V6 4motion	ch.→1J-Y-800000; for OE: 1GT	F8-6041		H=53
Rubber Buffer, suspension	2.8 V6 4motion	ch.1J-1-000001→; for OE: G88	F8-6041		H=53
Rubber Buffer, suspension	2.8 V6 4motion	for OE: G88; SP	F8-6041		H=53
Protective Cap/Bellow, shock absorber	1.4 16V, 1.6, 1.6 16V, 1.6 FSI, 1.8 T, 1.9 TDI, 2.0, 2.3 V5	Δ	F8-6044		H=160
Protective Cap/Bellow, shock absorber	1.8 T, 2.8 VR6	for OE: 1JG, 1JH; Δ, ST	F8-6044		H=160
Protective Cap/Bellow, shock absorber	1.4 16V, 1.6, 1.6 16V, 1.6 FSI, 1.8 T, 1.9 TDI, 2.0, 2.3 V5		F8-6045		
Mounting, axle beam	1.4 16V, 1.6, 1.6 16V, 1.6 FSI, 1.8 T, 1.9 TDI, 2.0, 2.3 V5		F8-6076		d=12; L=90; D=69
Repair Set, axle beam	1.4 16V, 1.6, 1.6 16V, 1.6 FSI, 1.8 T, 1.9 TDI, 2.0, 2.3 V5		F8-6077		H=90; D=69
Repair Set, axle beam	1.6	AKL	F8-6077		H=90; D=69
Top Strut Mounting	1.4 16V, 1.6, 1.6 16V, 1.6 FSI, 1.8 4motion, 1.8 T, 1.9 TDI, 1.9 TDI 4motion, 2.0, 2.0 4motion, 2.3 V5, 2.3 V5 4motion, 2.8 V6 4motion		F8-6280		H=53; d=26; D=82
Belt Pulley, crankshaft	1.9 TDI	01/2002 →; Number of Ribs: 5; Parameter: 6PK	F8-6392		H=47; d=30; D=143
Belt Pulley, crankshaft	1.9 TDI, 1.9 TDI 4motion	05/2001 →; Engine →435000; Number of Ribs: 5; Parameter: 6PK	F8-6392		H=47; d=30; D=143
Belt Pulley, crankshaft	1.9 TDI, 1.9 TDI 4motion	Number of Ribs: 5; Parameter: 6PK	F8-6392		H=47; d=30; D=143
Belt Pulley, crankshaft	1.9 TDI	ch.1J-3D016001, 1J-3W350001→; Number of Ribs: 5; Parameter: 6PK	F8-6396		H=41.6; d=30; Mounting points diam.[mm]=7, 8.6; D=139.7
Bracket, stabilizer mounting	1.4 16V, 1.6, 1.6 16V, 1.6 FSI, 1.8 4motion, 1.8 T, 1.9 TDI, 1.9 TDI 4motion, 2.0, 2.0 4motion, 2.3 V5, 2.3 V5 4motion, 2.8 V6 4motion, 2.8 VR6		F8-6579		
Bracket, stabilizer mounting	1.6	AEH, AKL	F8-6579		
Engine Mounting	1.9 TDI, 1.9 TDI 4motion		F8-6960		
Mounting, axle bracket	1.8 4motion, 1.9 TDI 4motion, 2.0 4motion, 2.3 V5 4motion, 2.8 V6 4motion		F8-7046		H=55; d=16; D=52

<b>F8-6041</b>	<b>F8-6044</b>	<b>F8-6045</b>	<b>F8-6076</b>	<b>F8-6077</b>	<b>F8-6280</b>	<b>F8-6392</b>
Ref.Nr.: 1J0412303	Ref.Nr.: 3C0513425	Ref.Nr.: 1J0513425A	Ref.Nr.: 1J0501541D	Ref.Nr.: 1J0501541DS	Ref.Nr.: 6R0412249	Ref.Nr.: 038105243
<b>F8-6396</b>	<b>F8-6579</b>	<b>F8-6960</b>	<b>F8-7046</b>	<b>F8-7133</b>		
Ref.Nr.: 03G105243	Ref.Nr.: 1J0 411 336 C	Ref.Nr.: 1J0199262P	Ref.Nr.: 1J0505145B	Ref.Nr.: 1J0412319C		

**Article Description****Article Nr.****Fitting Position****BORA Estate (1J6)****05/1999 → 05/2005**

Top Strut Mounting	1.4 16V, 1.6, 1.6 16V, 1.6 FSI, 1.8 4motion, 1.8 T, 1.9 TDI, 1.9 TDI 4motion, 2.0, 2.0 4motion, 2.3 V5, 2.3 V5 4motion, 2.8 V6 4motion	for OE: 1J0412319C	<b>F8-7133</b>		
Belt Pulley, crankshaft	1.9 TDI	ch.→1J-3D016000, 1J-3W350000	<b>F8-7864</b>		
Stabiliser Mounting	1.8 4motion, 1.9 TDI 4motion, 2.0 4motion, 2.3 V5 4motion, 2.8 V6 4motion	ch.1J-Y-000 001→; ch.→1J-4-220000; for OE: 0AR	<b>F8-7901</b>		
Stabiliser Mounting	1.8 4motion, 1.9 TDI 4motion, 2.0 4motion, 2.3 V5 4motion, 2.8 V6 4motion		<b>F8-7927</b>		d=18
Stabiliser Mounting	1.4 16V, 1.6, 1.8 T, 1.9 TDI, 2.0		<b>F8-7936</b>		
Control Arm-/Trailing Arm Bush	All Models		<b>F8-7978</b>		
Engine Mounting	1.4 16V		<b>F8-8198</b>		
Control Arm-/Trailing Arm Bush	1.6, 1.6 16V, 1.6 FSI, 1.8 4motion, 1.8 T, 1.9 TDI, 1.9 TDI 4motion, 2.0, 2.0 4motion, 2.3 V5, 2.3 V5 4motion, 2.8 V6 4motion		<b>G9-648</b>		H=54; d=12; D1=33; D2=36
Control Arm-/Trailing Arm Bush	1.6, 1.6 16V, 1.6 FSI, 1.8 4motion, 1.8 T, 1.9 TDI, 1.9 TDI 4motion, 2.0, 2.0 4motion, 2.3 V5, 2.3 V5 4motion, 2.8 V6 4motion		<b>G9-649</b>		H1=25; H2=41; d=13; D=60
Bellow, steering	All Models	with clamps;	<b>LM-10020S</b>		d1=16; d2=48; L [mm]=179
Bellow Set, drive shaft	1.9 TDI	ATD; with clamps;	<b>MK-810160</b>		L=116
Bellow Set, drive shaft	2.3 V5	with clamps;	<b>MK-810160</b>		L=116

**CADDY (14)****08/1982 → 07/1992**

Dust Cover Kit, shock absorber	1.5, 1.6, 1.6 D, 1.8		<b>AK-733023</b>		
Engine Mounting	1.6, 1.8	ch.→14-J-009000	<b>F8-1001</b>		H1=42; H2=61; d=11; D=74.5
Top Strut Mounting	1.5, 1.6, 1.6 D, 1.8	with slide bearing	<b>F8-1002</b>		
Anti-Friction Bearing	1.5, 1.6, 1.6 D, 1.8		<b>F8-3036</b>		
Flange, carburettor	1.6		<b>F8-3044</b>		H=21
Rubber Buffer, silencer	1.5, 1.6, 1.6 D		<b>F8-4026</b>		H=12; W=57, 60
Clamp, silencer	1.6, 1.6 D	01/1985 →	<b>F8-4027</b>		H=17; W=53, 61
Clamp, silencer	1.8		<b>F8-4027</b>		H=17; W=53, 61
Bellow, steering	1.5, 1.6, 1.6 D, 1.8		<b>F8-4069</b>		
Bellow Set, steering	1.5, 1.6, 1.6 D, 1.8		<b>F8-4074</b>		H=125; D1=34; D2=39
Protective Cap/Bellow, shock absorber	1.5, 1.6, 1.6 D, 1.8		<b>F8-5694</b>		
Rubber Buffer, suspension	All Models		<b>F8-5755</b>		
Bellow, driveshaft	All Models		<b>F8-7722</b>		d1=26; d2=78; L=110
Control Arm-/Trailing Arm Bush	1.5, 1.6, 1.6 D, 1.8		<b>G9-540</b>		H=55; d=16; D=38
Control Arm-/Trailing Arm Bush	1.5, 1.6, 1.6 D, 1.8		<b>G9-541</b>		H=62; d=12; D=34

<b>AK-733023</b>	<b>F8-1001</b>	<b>F8-1002</b>	<b>F8-3036</b>	<b>F8-3044</b>	<b>F8-4026</b>	<b>F8-4027</b>
Ref.Nr.: 191412303	Ref.Nr.: 171199214K	Ref.Nr.: 171412329A	Ref.Nr.: 377412335A	Ref.Nr.: 026129761A	Ref.Nr.: 817253147	Ref.Nr.: 171253147A
<b>F8-4069</b>	<b>F8-4074</b>	<b>F8-5694</b>	<b>F8-5755</b>	<b>F8-7133</b>	<b>F8-7722</b>	<b>F8-7864</b>
Ref.Nr.: 171419831B	Ref.Nr.: 171419832A	Ref.Nr.: 171412135	Ref.Nr.: 171412303C	Ref.Nr.: 1J0412319C	Ref.Nr.: 191407285F	Ref.Nr.: 038 105 243
<b>F8-7901</b>	<b>F8-7927</b>	<b>F8-7936</b>	<b>F8-7978</b>	<b>F8-8198</b>	<b>G9-540</b>	<b>G9-541</b>
Ref.Nr.: 1J0411314P	Ref.Nr.: 1J0411314AC	Ref.Nr.: 1J0411327A	Ref.Nr.: 357407182F	Ref.Nr.: 1J0199555BD	Ref.Nr.: 171407181A	Ref.Nr.: 171407182D

Article Description



Article Nr.

Fitting Position



<b>CADDY (14)</b>			<b>08/1982 → 07/1992</b>		
Bellow, steering	All Models	with clamps;	<b>LM-10024S</b>		d1=25; d2=41; L [mm]=120
Bellow, steering	All Models	with clamps;	<b>LM-10050S</b>		d1=25; d2=39; L [mm]=126
Bellow, steering	All Models	with clamps	<b>LM-10064S</b>		d1=25; d2=35; L [mm]=144
Bellow, driveshaft	All Models		<b>M-830220</b>		
Bellow Set, drive shaft	All Models		<b>MK-830220</b>		
Bellow Set, drive shaft	1.5, 1.6		<b>MK-830220S</b>		

<b>CADDY Mk II (9K9A)</b>			<b>11/1995 → 01/2004</b>		
Dust Cover Kit, shock absorber	1.4, 1.7 SDI, 1.9 D, 1.9 SDI, 1.9 TDI		<b>AK-733023</b>		
Alternator Freewheel Clutch	1.9 SDI, 1.9 TDI		<b>F5-1004</b>		
Alternator Freewheel Clutch	1.7 SDI, 1.9 SDI, 1.9 TDI		<b>F5-1007</b>		
Control Arm-/Trailing Arm Bush	1.9 D, 1.9 TDI, 75 1.6	without guide sleeve	<b>F8-1007</b>		H1=26; H2=41; d=17; D1=60; D2=68
Control Arm-/Trailing Arm Bush	1.9 SDI, 60 1.4, 75 1.6	01/1996 →; without guide sleeve	<b>F8-1007</b>		H1=26; H2=41; d=17; D1=60; D2=68
Control Arm-/Trailing Arm Bush	1.9 D, 1.9 SDI, 1.9 TDI, 60 1.4, 75 1.6	with guide sleeve	<b>F8-1007S</b>		H1=26; H2=41; d=17; D1=60; D2=68
Repair Kit, link	1.4, 1.7 SDI, 1.9 D, 1.9 TDI, 75 1.6	with guide sleeve	<b>F8-1008</b>		H1=24; H2=41; d=17; D=60
Repair Kit, link	1.9 SDI, 60 1.4, 75 1.6	01/1996 →; with guide sleeve	<b>F8-1008</b>		H1=24; H2=41; d=17; D=60
Engine Mounting	1.9 TDI, 75 1.6		<b>F8-1011</b>		H=133; D1=80; D2=108
Engine Mounting	1.7 SDI, 1.9 D, 1.9 SDI, 75 1.6		<b>F8-1015</b>		H=82; D1=55; D2=71
Top Strut Mounting	1.9 SDI, 1.9 TDI, 60 1.4, 75 1.6		<b>F8-1034</b>		H=50; d=27; D=98
Top Strut Mounting	1.9 SDI, 1.9 TDI, 60 1.4, 75 1.6		<b>F8-1034S</b>		H=51; d=14; D=96
Anti-Friction Bearing	All Models		<b>F8-3039</b>		H=14; d1=14; D=45
Stabiliser Mounting	All Models		<b>F8-3042</b>		H=33; d=17; W=35
Engine Mounting	1.7 SDI, 1.9 D, 1.9 SDI		<b>F8-3053</b>		H=135; D1=79; D2=93
Engine Mounting	1.9 D, 1.9 SDI		<b>F8-4016</b>		
Engine Mounting	60 1.4		<b>F8-4017</b>		
Mounting, steering gear	All Models		<b>F8-5394</b>		
Stabiliser Mounting	1.4, 1.7 SDI, 75 1.6	ch.9K-V-525701→; Stabi. Diam. [mm]=20	<b>F8-5395</b>		d=19
Stabiliser Mounting	1.9 D, 1.9 SDI, 1.9 TDI, 60 1.4, 75 1.6	ch.9K-V-525701→	<b>F8-5395</b>		d=19
Engine Mounting	1.9 TDI	AHU	<b>F8-5396</b>		
Engine Mounting	75 1.6		<b>F8-5397</b>		
Engine Mounting	60 1.4		<b>F8-5398</b>		
Engine Mounting	1.9 TDI	Box	<b>F8-5491</b>		
Engine Mounting	1.9 D, 60 1.4, 75 1.6		<b>F8-5554</b>		H=39.5; d1=16; d2=24; D=50

<b>AK-733023</b>	<b>F5-1004</b>	<b>F5-1007</b>	<b>F8-1007</b>	<b>F8-1007S</b>	<b>F8-1008</b>	<b>F8-1011</b>
Ref.Nr.: 191412303	Ref.Nr.: 038903119T	Ref.Nr.: 028903119AQ	Ref.Nr.: 191407181A	Ref.Nr.: 191407181A	Ref.Nr.: 191407181E	Ref.Nr.: 1H0199262F
<b>F8-1015</b>	<b>F8-1034</b>	<b>F8-1034S</b>	<b>F8-3039</b>	<b>F8-3042</b>	<b>F8-3053</b>	<b>F8-4016</b>
Ref.Nr.: 357199402	Ref.Nr.: 357412331A	Ref.Nr.: 7201848S1	Ref.Nr.: 357412249A	Ref.Nr.: 191411314	Ref.Nr.: 1H0199609B	Ref.Nr.: 1H0199262G
<b>F8-4017</b>	<b>F8-5394</b>	<b>F8-5395</b>	<b>F8-5396</b>	<b>F8-5397</b>	<b>F8-5398</b>	<b>F8-5491</b>
Ref.Nr.: 1H0199262E	Ref.Nr.: 1H0422884	Ref.Nr.: 1H0411314	Ref.Nr.: 1H0199609J	Ref.Nr.: 1H0199609F	Ref.Nr.: 1H0199609E	Ref.Nr.: 357199381



**Article Description****Article Nr.****Fitting Position****CADDY Mk II (9K9A) 11/1995 → 01/2004**

Belt Pulley, crankshaft	1.7 SDI, 1.9 D, 1.9 SDI, 1.9 TDI	Number of Ribs: 5; Parameter: 6PK	<b>F8-5649</b>		H=31.5; d=30.02; Mounting points diam.[mm]=8.5; D1=161.5; D2=160.5
Holder, engine mounting	1.7 SDI, 1.9 D, 1.9 SDI, 1.9 TDI		<b>F8-5672</b>		H=39.5; D=24
Belt Pulley, crankshaft	1.9 TDI	ALH; Engine 896340→; Number of Ribs: 5; Parameter: 6PK	<b>F8-6396</b>		H=41.6; d=30; Mounting points diam.[mm]=7, 8.6; D=139.7
Sleeve, control arm mounting	All Models		<b>F8-6699</b>		d=16; L=50; D=17
Engine Mounting	1.9 SDI	AYQ	<b>F8-6922</b>		H=65
Engine Mounting	60 1.4		<b>F8-6922</b>		H=65
Engine Mounting	75 1.6	AEE	<b>F8-6922</b>		H=65
Bellow, driveshaft	1.9 D, 75 1.6		<b>F8-7722</b>		d1=26; d2=78; L=110
Bellow, driveshaft	1.9 SDI	AEY	<b>F8-7722</b>		d1=26; d2=78; L=110
Bellow, driveshaft	60 1.4	AEX	<b>F8-7722</b>		d1=26; d2=78; L=110
Belt Pulley, crankshaft	1.9 TDI	ALH; Engine →896339	<b>F8-7864</b>		
Stabiliser Mounting	1.4		<b>F8-7936</b>		
Control Arm-/Trailing Arm Bush	All Models		<b>F8-7978</b>		
Control Arm-/Trailing Arm Bush	1.4, 1.7 SDI, 1.9 D, 1.9 SDI, 1.9 TDI, 60 1.4, 75 1.6		<b>G9-648</b>		H=54; d=12; D1=33; D2=36
Bellow, steering	All Models	with clamps;	<b>LM-10003S</b>		d1=9; d2=43; L [mm]=210
Bellow, steering	All Models	with clamps	<b>LM-10006S</b>		d1=10; d2=41; L [mm]=210
Bellow, driveshaft	1.9 D, 1.9 SDI, 60 1.4, 75 1.6		<b>M-830220</b>		
Bellow Set, drive shaft	1.9 D, 75 1.6		<b>MK-830220</b>		
Bellow Set, drive shaft	1.9 SDI	AEY	<b>MK-830220</b>		
Bellow Set, drive shaft	60 1.4	AEX	<b>MK-830220</b>		
Bellow Set, drive shaft	1.9 D, 75 1.6		<b>MK-830220S</b>		

**CADDY II Estate (9K9B) 11/1995 → 01/2004**

Alternator Freewheel Clutch	1.9 SDI, 1.9 TDI		<b>F5-1004</b>		
Alternator Freewheel Clutch	1.7 SDI, 1.9 SDI, 1.9 TDI		<b>F5-1007</b>		
Control Arm-/Trailing Arm Bush	1.4	without guide sleeve	<b>F8-1007</b>		H1=26; H2=41; d=17; D1=60; D2=68
Control Arm-/Trailing Arm Bush	1.4	with guide sleeve	<b>F8-1007S</b>		H1=26; H2=41; d=17; D1=60; D2=68
Repair Kit, link	1.4, 1.4 16V, 1.6, 1.9 D, 1.9 SDI, 1.9 TDI	with guide sleeve	<b>F8-1008</b>		H1=24; H2=41; d=17; D=60
Anti-Friction Bearing	All Models		<b>F8-3039</b>		H=14; d1=14; D=45
Stabiliser Mounting	All Models		<b>F8-3042</b>		H=33; d=17; W=35
Mounting, steering gear	1.4	AKV	<b>F8-5394</b>		

<b>F5-1004</b>	<b>F5-1007</b>	<b>F8-1007</b>	<b>F8-1007S</b>	<b>F8-1008</b>	<b>F8-3039</b>	<b>F8-3042</b>
Ref.Nr.: 038903119T	Ref.Nr.: 028903119AQ	Ref.Nr.: 191407181A	Ref.Nr.: 191407181A	Ref.Nr.: 191407181E	Ref.Nr.: 357412249A	Ref.Nr.: 191411314
<b>F8-5394</b>	<b>F8-5395</b>	<b>F8-5649</b>	<b>F8-5672</b>	<b>F8-6396</b>	<b>F8-6699</b>	<b>F8-6922</b>
Ref.Nr.: 1H0422884	Ref.Nr.: 1H0411314	Ref.Nr.: 028105243T	Ref.Nr.: 1H0199233A	Ref.Nr.: 03G105243	Ref.Nr.: 191407190A	Ref.Nr.: 191199381A
<b>F8-7722</b>	<b>F8-7864</b>	<b>F8-7936</b>	<b>F8-7978</b>	<b>G9-648</b>	<b>LM-10003S</b>	<b>LM-10006S</b>
Ref.Nr.: 191407285F	Ref.Nr.: 038 105 243	Ref.Nr.: 1J0411327A	Ref.Nr.: 357407182F	Ref.Nr.: 357407182	Ref.Nr.: 357422831A	Ref.Nr.: 1H0422831B

Article Description



Article Nr.

Fitting Position



<b>CADDY II Estate (9K9B)</b>			<b>11/1995 → 01/2004</b>		
Stabiliser Mounting	1.4, 1.4 16V, 1.6, 1.7 SDI, 1.9 D, 1.9 SDI	ch.9K-V-525701→; Stabi. Diam. [mm]=20	<b>F8-5395</b>		d=19
Stabiliser Mounting	1.9 TDI	ch.9K-V-525701→;  AHU; Stabi. Diam. [mm]=20	<b>F8-5395</b>		d=19
Belt Pulley, crankshaft	1.7 SDI, 1.9 D, 1.9 SDI, 1.9 TDI	Number of Ribs: 5; Parameter: 6PK	<b>F8-5649</b>		H=31.5; d=30.02; Mounting points diam.[mm]=8.5; D1=161.5; D2=160.5
Belt Pulley, crankshaft	1.9 TDI	ALH; Engine896340→; Number of Ribs: 5; Parameter: 6PK	<b>F8-6396</b>		H=41.6; d=30; Mounting points diam.[mm]=7, 8.6; D=139.7
Sleeve, control arm mounting	All Models		<b>F8-6699</b>		d=16; L=50; D=17
Belt Pulley, crankshaft	1.9 TDI	ALH; Engine →896339	<b>F8-7864</b>		
Stabiliser Mounting	1.4 16V		<b>F8-7936</b>		
Control Arm-/Trailing Arm Bush	All Models		<b>F8-7978</b>		
<b>CADDY Mk II (9U7)</b>			<b>06/1996 → 12/2000</b>		
Dust Cover Kit, shock absorber	All Models		<b>AK-733023</b>		
Alternator Freewheel Clutch	1.9 D		<b>F5-1010</b>		
Control Arm-/Trailing Arm Bush	All Models	without guide sleeve	<b>F8-1007</b>		H1=26; H2=41; d=17; D1=60; D2=68
Control Arm-/Trailing Arm Bush	All Models	with guide sleeve	<b>F8-1007S</b>		H1=26; H2=41; d=17; D1=60; D2=68
Repair Kit, link	All Models	with guide sleeve	<b>F8-1008</b>		H1=24; H2=41; d=17; D=60
Anti-Friction Bearing	All Models		<b>F8-3039</b>		H=14; d1=14; D=45
Stabiliser Mounting	All Models		<b>F8-3042</b>		H=33; d=17; W=35
Belt Pulley, crankshaft	1.9 D	Number of Ribs: 5	<b>F8-6398</b>		
Rubber Buffer, suspension	All Models		<b>F8-7674</b>		H=155
Control Arm-/Trailing Arm Bush	All Models		<b>G9-648</b>		H=54; d=12; D1=33; D2=36
<b>CADDY III Box (2KA, 2KH, 2CA, 2CH)</b>			<b>03/2004 → 08/2010</b>		
Dust Cover Kit, shock absorber	1.4, 1.4 16V, 1.6, 1.9 TDI, 2.0 EcoFuel, 2.0 SDI		<b>AK-733023</b>		
Alternator Freewheel Clutch	1.6, 1.6 BiFuel, 1.6 TDI, 1.9 TDI, 1.9 TDI 4motion, 2.0 EcoFuel, 2.0 SDI, 2.0 TDI, 2.0 TDI 16V, 2.0 TDI 16V 4motion, 2.0 TDI 4motion		<b>F5-1004</b>		
Alternator Freewheel Clutch	1.2 TSI		<b>F5-1064</b>		
Control Arm-/Trailing Arm Bush	All Models		<b>F8-5633</b>		
Belt Pulley, crankshaft	2.0 EcoFuel		<b>F8-5650</b>		
Top Strut Mounting	All Models		<b>F8-6284</b>		
Belt Pulley, crankshaft	1.9 TDI, 2.0 SDI	Number of Ribs: 5; Parameter: 6PK	<b>F8-6396</b>		H=41.6; d=30; Mounting points diam.[mm]=7, 8.6; D=139.7

<b>AK-733023</b>	<b>F5-1004</b>	<b>F5-1010</b>	<b>F5-1064</b>	<b>F8-1007</b>	<b>F8-1007S</b>	<b>F8-1008</b>
Ref.Nr.: 191412303	Ref.Nr.: 038903119T	Ref.Nr.: 028903119S	Ref.Nr.: 03C903119D	Ref.Nr.: 191407181A	Ref.Nr.: 191407181A	Ref.Nr.: 191407181E
<b>F8-3039</b>	<b>F8-3042</b>	<b>F8-5395</b>	<b>F8-5633</b>	<b>F8-5649</b>	<b>F8-5650</b>	<b>F8-6284</b>
Ref.Nr.: 357412249A	Ref.Nr.: 191411314	Ref.Nr.: 1H0411314	Ref.Nr.: 1K0407182A	Ref.Nr.: 028105243T	Ref.Nr.: 06A105243E	Ref.Nr.: 6N0412249C
<b>F8-6396</b>	<b>F8-6398</b>	<b>F8-6424</b>	<b>F8-6699</b>	<b>F8-7674</b>	<b>F8-7864</b>	<b>F8-7936</b>
Ref.Nr.: 03G105243	Ref.Nr.: 028 105 243AC	Ref.Nr.: 1K0199232G	Ref.Nr.: 191407190A	Ref.Nr.: 6U0512131C	Ref.Nr.: 038 105 243	Ref.Nr.: 1J0411327A

**Article Description****Article Nr.****Fitting Position****CADDY III Box (2KA, 2KH, 2CA, 2CH)****03/2004 → 08/2010**

Control Arm-/Trailing Arm Bush	1.4, 1.4 16V, 1.6, 1.9 TDI, 2.0 EcoFuel, 2.0 SDI, 2.0 TDI	Aluminium	<b>F8-6424</b>		
Control Arm-/Trailing Arm Bush	1.4, 1.4 16V, 1.6, 1.9 TDI, 2.0 EcoFuel, 2.0 SDI, 2.0 TDI	Aluminium	<b>F8-6425</b>		
Engine Mounting	2.0 TDI		<b>F8-6528</b>		
Anti-Friction Bearing	All Models		<b>F8-6569</b>		
Top Strut Mounting	All Models		<b>F8-6570</b>		
Belt Pulley, crankshaft	1.6 TDI, 2.0 TDI, 2.0 TDI 16V, 2.0 TDI 16V 4motion, 2.0 TDI 4motion	Number of Ribs: 5; Parameter: 6PK	<b>F8-6572</b>		
Engine Mounting	2.0 EcoFuel		<b>F8-6989</b>		
Engine Mounting	1.4		<b>F8-6991</b>		
Protective Cap/Bellow, shock absorber	1.2 TSI, 1.4, 1.4 16V, 1.6, 1.6 TDI, 1.9 TDI, 1.9 TDI 4motion, 2.0 EcoFuel, 2.0 SDI, 2.0 TDI, 2.0 TDI 16V, 2.0 TDI 16V 4motion, 2.0 TDI 4motion		<b>F8-7132</b>		H=190
Rubber Buffer, suspension	1.4, 1.4 16V, 1.6, 1.9 TDI, 2.0 EcoFuel, 2.0 SDI, 2.0 TDI	ch.→2K-5-100000; <b>HD</b>	<b>F8-7174</b>		H=80
Rubber Buffer, suspension	1.4, 1.4 16V, 1.6, 1.9 TDI, 2.0 SDI, 2.0 TDI	; ch.2K-5-063 464→	<b>F8-7679</b>		
Rubber Buffer, suspension	1.2 TSI, 1.6 BiFuel, 1.6 TDI, 2.0 TDI, 2.0 TDI 16V	for OE: 1BA, 1BJ, 1ZF, A8C, A8G, A8M; <b>△</b>	<b>F8-7703</b>		H=90; d=25
Rubber Buffer, suspension	1.4 16V, 1.9 TDI, 2.0 EcoFuel	for OE: 1BA, 1BJ, 1ZF, 1ZM, A9J; <b>△</b>	<b>F8-7703</b>		H=90; d=25
Rubber Buffer, suspension	1.4, 1.6, 1.9 TDI, 2.0 SDI, 2.0 TDI	ch.2K-5-065001→; for OE: 1BA, 1BJ, 1ZF, 1ZM, A9J; <b>△</b>	<b>F8-7703</b>		H=90; d=25
Stabiliser Mounting	1.2 TSI, 1.6 BiFuel, 1.6 TDI, 2.0 TDI, 2.0 TDI 16V	for OE: 0E1; Stabi. Diam. [mm]= 20;	<b>F8-7798</b>		d=19; $\tau$ [mm]=2682
Stabiliser Mounting	1.4 16V, 1.6, 1.9 TDI, 2.0 EcoFuel, 2.0 SDI	09/2007 →; for OE: 0E1; Stabi. Diam. [mm]= 20;	<b>F8-7798</b>		d=19; $\tau$ [mm]=2682
Stabiliser Mounting	1.4, 1.4 16V, 1.6, 1.9 TDI, 2.0 EcoFuel, 2.0 SDI, 2.0 TDI	Stabi. Diam. [mm]= 20	<b>F8-7798</b>		d=19
Rubber Buffer, suspension	1.4, 1.4 16V, 1.6, 1.9 TDI, 1.9 TDI 4motion, 2.0 EcoFuel, 2.0 SDI, 2.0 TDI	ch.2K-5-065001→; for OE: 1BA, 1BH, A9H, A9L, A9M; <b>ST</b>	<b>F8-7831</b>		H=90; $\tau$ [mm]=2682
Rubber Buffer, suspension	1.4, 1.4 16V, 1.6, 1.9 TDI, 1.9 TDI 4motion, 2.0 EcoFuel, 2.0 SDI, 2.0 TDI	ch.2K-5-065001→; for OE: 1ZF, 1ZM, 2MK; <b>ST</b>	<b>F8-7831</b>		H=90; $\tau$ [mm]=2682
Rubber Buffer, suspension	1.4, 1.4 16V, 1.6, 1.9 TDI, 2.0 EcoFuel, 2.0 SDI	ch.→2K-5-065000; for OE: 1BA, 1ZM; <b>ST</b>	<b>F8-7831</b>		H=90
Rubber Buffer, suspension	1.6, 1.6 BiFuel, 1.6 TDI, 2.0 TDI, 2.0 TDI 16V, 2.0 TDI 16V 4motion, 2.0 TDI 4motion	for OE: 1BA, 1BH, 1ZF, 2MK, A8B, A9H, A9L, A9M; <b>ST</b>	<b>F8-7831</b>		H=90; $\tau$ [mm]=2682
Rubber Buffer, suspension	1.2 TSI, 1.4 16V, 1.6, 1.6 BiFuel, 1.6 TDI, 1.9 TDI, 1.9 TDI 4motion, 2.0 EcoFuel, 2.0 SDI, 2.0 TDI, 2.0 TDI 16V, 2.0 TDI 16V 4motion, 2.0 TDI 4motion	for OE: 1LJ, 2MD, 2MH+1ZE; <b>ST</b>	<b>F8-7832</b>		H=85; $\tau$ [mm]=2682
Rubber Buffer, suspension	1.2 TSI, 1.6 BiFuel, 1.6 TDI, 2.0 TDI, 2.0 TDI 16V	for OE: 1BA, A8C, A8G, A8M; <b>ST</b>	<b>F8-7834</b>		H=90; $\tau$ [mm]=2682
Rubber Buffer, suspension	1.2 TSI, 1.6 BiFuel, 1.6 TDI, 2.0 TDI, 2.0 TDI 16V	for OE: 1BJ, 1ZA, 1ZE, 2MK; <b>HD</b>	<b>F8-7834</b>		H=90; $\tau$ [mm]=2682
Rubber Buffer, suspension	1.4	ch.2K-5-065001→; for OE: 1BA, 1LJ, 1ZE, A9J; <b>ST</b>	<b>F8-7834</b>		H=90; $\tau$ [mm]=2682

<b>F8-6424</b>	<b>F8-6425</b>	<b>F8-6528</b>	<b>F8-6569</b>	<b>F8-6570</b>	<b>F8-6572</b>	<b>F8-6989</b>
Ref.Nr.: 1K0199232G	Ref.Nr.: 1K0199231J	Ref.Nr.: 1K0 199 262 AT	Ref.Nr.: 6N0412249C	Ref.Nr.: 1K0412331C	Ref.Nr.: 038105243L	Ref.Nr.: 1K0199262AM
<b>F8-6991</b>	<b>F8-7132</b>	<b>F8-7174</b>	<b>F8-7679</b>	<b>F8-7703</b>	<b>F8-7798</b>	<b>F8-7831</b>
Ref.Nr.: 1K0199262AK	Ref.Nr.: 6N0413175A	Ref.Nr.: 1K0412303M	Ref.Nr.: 2K0511155	Ref.Nr.: 1K0412303G	Ref.Nr.: 2K0511413C	Ref.Nr.: 1K0412303S
<b>F8-7832</b>	<b>F8-7834</b>					
Ref.Nr.: 1K0412303P	Ref.Nr.: 1K0412303H					

Article Description



Article Nr.

Fitting Position



**CADDY III Box (2KA, 2KH, 2CA, 2CH)** 03/2004 → 08/2010

Rubber Buffer, suspension	1.4	for OE: 1BJ, 1LJ, 1ZE; <b>HD</b>	<b>F8-7834</b>		H=90; T [mm]=2682
Rubber Buffer, suspension	1.4 16V, 1.6, 1.6 TDI, 1.9 TDI, 2.0 EcoFuel, 2.0 SDI, 2.0 TDI	ch.2K-B-200001→; for OE: 1BJ, 1ZA, 1ZE, 2MK; <b>HD</b>	<b>F8-7834</b>		H=90; T [mm]=2682
Rubber Buffer, suspension	1.4 16V, 1.6, 1.9 TDI, 2.0 EcoFuel, 2.0 SDI	ch.2K-5-065001→; ch.→2K-B-005000; for OE: 1BA, 1LJ, 1ZE, A9J; <b>ST</b>	<b>F8-7834</b>		H=90; T [mm]=2682
Rubber Buffer, suspension	1.4 16V, 1.6, 1.9 TDI, 2.0 EcoFuel, 2.0 SDI, 2.0 TDI	ch.→2K-B-005000; for OE: 1BJ, 1LJ, 1ZE; <b>HD</b>	<b>F8-7834</b>		H=90; T [mm]=2682
Rubber Buffer, suspension	1.4 16V, 1.6, 1.9 TDI, 2.0 EcoFuel, 2.0 SDI, 2.0 TDI	ch.2K-B-200001→; for OE: 1BA, A8C, A8G, A8M; <b>ST</b>	<b>F8-7834</b>		H=90; T [mm]=2682
Rubber Buffer, suspension	2.0 TDI	ch.→2K-B-005000; for OE: 1BA, 1LJ, 1ZE, A9J; <b>ST</b>	<b>F8-7834</b>		H=90; T [mm]=2682
Control Arm-/Trailing Arm Bush	1.2 TSI, 1.6 BiFuel, 1.6 TDI, 1.9 TDI 4motion, 2.0 TDI, 2.0 TDI 16V, 2.0 TDI 16V 4motion, 2.0 TDI 4motion		<b>F8-7856</b>		H=50; d=13.2; D=65
Control Arm-/Trailing Arm Bush	1.4 16V, 1.6, 1.9 TDI, 2.0 EcoFuel, 2.0 SDI, 2.0 TDI	06/2010 →	<b>F8-7856</b>		H=50; d=13.2; D=65
Engine Mounting	1.2 TSI, 1.4, 1.4 16V, 1.6, 1.6 BiFuel		<b>F8-7960</b>		
Engine Mounting	1.9 TDI		<b>F8-7962</b>		
Engine Mounting	1.9 TDI	BLS;	<b>F8-7962</b>		
Engine Mounting	1.4, 1.4 16V, 1.6, 2.0 EcoFuel, 2.0 SDI		<b>F8-7965</b>		
Engine Mounting	1.9 TDI, 2.0 TDI		<b>F8-7966</b>		
Engine Mounting	All Models		<b>F8-7982</b>		
Engine Mounting	1.9 TDI 4motion		<b>F8-8152</b>		
Engine Mounting	2.0 TDI, 2.0 TDI 16V, 2.0 TDI 16V 4motion, 2.0 TDI 4motion	6-speed	<b>F8-8152</b>		

**CADDY III Estate (2KB, 2KJ, 2CB, 2CJ)** 03/2004 → 08/2010

Dust Cover Kit, shock absorber	1.4, 1.4 16V, 1.6, 1.9 TDI, 2.0 EcoFuel, 2.0 SDI		<b>AK-733023</b>		
Alternator Freewheel Clutch	1.6 BiFuel, 1.6 TDI, 1.9 TDI, 1.9 TDI 4motion, 2.0 EcoFuel, 2.0 SDI, 2.0 TDI, 2.0 TDI 16V, 2.0 TDI 16V 4motion, 2.0 TDI 4motion		<b>F5-1004</b>		
Alternator Freewheel Clutch	1.2 TSI		<b>F5-1064</b>		
Control Arm-/Trailing Arm Bush	All Models		<b>F8-5633</b>		
Belt Pulley, crankshaft	2.0 EcoFuel		<b>F8-5650</b>		
Top Strut Mounting	All Models		<b>F8-6284</b>		
Belt Pulley, crankshaft	1.9 TDI, 2.0 SDI	Number of Ribs: 5; Parameter: 6PK	<b>F8-6396</b>		H=41.6; d=30; Mounting points diam.[mm]=7, 8.6; D=139.7
Control Arm-/Trailing Arm Bush	1.4, 1.4 16V, 1.6, 1.9 TDI, 1.9 TDI 4motion, 2.0 EcoFuel, 2.0 SDI, 2.0 TDI	Aluminium	<b>F8-6424</b>		
Control Arm-/Trailing Arm Bush	1.4, 1.4 16V, 1.6, 1.9 TDI, 1.9 TDI 4motion, 2.0 EcoFuel, 2.0 SDI, 2.0 TDI	Aluminium	<b>F8-6425</b>		
Engine Mounting	2.0 TDI		<b>F8-6528</b>		



**Article Description****Article Nr.****Fitting Position**

<b>CADDY III Estate (2KB, 2KJ, 2CB, 2CJ)</b>			<b>03/2004 → 08/2010</b>		
Anti-Friction Bearing	All Models		<b>F8-6569</b>		
Top Strut Mounting	All Models		<b>F8-6570</b>		
Belt Pulley, crankshaft	1.6 TDI, 2.0 TDI, 2.0 TDI 16V, 2.0 TDI 16V 4motion, 2.0 TDI 4motion	Number of Ribs: 5; Parameter: 6PK	<b>F8-6572</b>		
Engine Mounting	1.6		<b>F8-6988</b>		
Engine Mounting	2.0 EcoFuel		<b>F8-6989</b>		
Engine Mounting	1.4		<b>F8-6991</b>		
Protective Cap/Bellow, shock absorber	1.2 TSI, 1.4, 1.4 16V, 1.6, 1.6 TDI, 1.9 TDI, 1.9 TDI 4motion, 2.0 EcoFuel, 2.0 SDI, 2.0 TDI, 2.0 TDI 16V, 2.0 TDI 16V 4motion, 2.0 TDI 4motion		<b>F8-7132</b>		H=190
Rubber Buffer, suspension	1.4, 1.4 16V, 1.6, 1.9 TDI, 1.9 TDI 4motion, 2.0 EcoFuel, 2.0 SDI, 2.0 TDI	ch.→2K-5-100000; <b>HD</b>	<b>F8-7174</b>		H=80
Rubber Buffer, suspension	1.4, 1.4 16V, 1.6, 1.9 TDI, 2.0 SDI, 2.0 TDI	; ch.2K-5-063 464→	<b>F8-7679</b>		
Rubber Buffer, suspension	1.2 TSI, 1.6 BiFuel, 1.6 TDI, 2.0 TDI, 2.0 TDI 16V	for OE: 1BA, 1BJ, 1ZF, A8C, A8G, A8M; <b>Δ</b>	<b>F8-7703</b>		H=90; d=25
Rubber Buffer, suspension	1.4 16V, 1.9 TDI	for OE: 1BA, 1BJ, 1ZF, 1ZM, A9J; <b>Δ</b>	<b>F8-7703</b>		H=90; d=25
Rubber Buffer, suspension	1.4, 1.6, 1.9 TDI, 2.0 SDI, 2.0 TDI	ch.2K-5-065001→; for OE: 1BA, 1BJ, 1ZF, 1ZM, A9J; <b>Δ</b>	<b>F8-7703</b>		H=90; d=25
Rubber Buffer, suspension	2.0 EcoFuel	ch.→2K-8-035369; for OE: 1BA, 1BJ, 1ZF, 1ZM, A9J; <b>Δ</b>	<b>F8-7703</b>		H=90; d=25
Stabiliser Mounting	1.2 TSI, 1.6 BiFuel, 1.6 TDI, 2.0 TDI, 2.0 TDI 16V	for OE: 0E1; Stabi. Diam. [mm]= 20;	<b>F8-7798</b>		d=19; $\tau$ [mm]=2682
Stabiliser Mounting	1.4 16V, 1.6, 1.9 TDI, 2.0 EcoFuel, 2.0 SDI	09/2007 →; for OE: 0E1; Stabi. Diam. [mm]= 20;	<b>F8-7798</b>		d=19; $\tau$ [mm]=2682
Stabiliser Mounting	1.4, 1.4 16V, 1.6, 1.9 TDI, 2.0 EcoFuel, 2.0 SDI, 2.0 TDI	Stabi. Diam. [mm]= 20	<b>F8-7798</b>		d=19
Rubber Buffer, suspension	1.2 TSI, 1.6, 1.6 BiFuel, 1.6 TDI, 2.0 TDI, 2.0 TDI 16V, 2.0 TDI 16V 4motion, 2.0 TDI 4motion	for OE: 1BA, 1BH, 1ZF, 2MK, A8B, A9H, A9L, A9M; <b>ST</b>	<b>F8-7831</b>		H=90; $\tau$ [mm]=2682
Rubber Buffer, suspension	1.4, 1.4 16V, 1.6, 1.9 TDI, 1.9 TDI 4motion, 2.0 EcoFuel, 2.0 SDI, 2.0 TDI	ch.2K-5-065001→; for OE: 1BA, 1BH, A9H, A9L, A9M; <b>ST</b>	<b>F8-7831</b>		H=90; $\tau$ [mm]=2682
Rubber Buffer, suspension	1.4, 1.4 16V, 1.6, 1.9 TDI, 1.9 TDI 4motion, 2.0 EcoFuel, 2.0 SDI, 2.0 TDI	ch.2K-5-065001→; for OE: 1ZF, 1ZM, 2MK; <b>ST</b>	<b>F8-7831</b>		H=90; $\tau$ [mm]=2682
Rubber Buffer, suspension	1.4, 1.4 16V, 1.6, 1.9 TDI, 2.0 EcoFuel, 2.0 SDI	ch.→2K-5-065000; for OE: 1BA, 1ZM; <b>ST</b>	<b>F8-7831</b>		H=90
Rubber Buffer, suspension	1.2 TSI, 1.4 16V, 1.6, 1.6 BiFuel, 1.6 TDI, 1.9 TDI, 1.9 TDI 4motion, 2.0 EcoFuel, 2.0 SDI, 2.0 TDI, 2.0 TDI 16V, 2.0 TDI 16V 4motion, 2.0 TDI 4motion	for OE: 1LJ, 2MD, 2MH+1ZE; <b>Q1</b>	<b>F8-7832</b>		H=85; $\tau$ [mm]=2682
Rubber Buffer, suspension	1.2 TSI, 1.6 BiFuel, 1.6 TDI, 2.0 TDI, 2.0 TDI 16V	for OE: 1BA, A8C, A8G, A8M; <b>ST</b>	<b>F8-7834</b>		H=90; $\tau$ [mm]=2682
Rubber Buffer, suspension	1.2 TSI, 1.6 BiFuel, 1.6 TDI, 2.0 TDI, 2.0 TDI 16V	for OE: 1BJ, 1ZA, 1ZE, 2MK; <b>HD</b>	<b>F8-7834</b>		H=90; $\tau$ [mm]=2682
Rubber Buffer, suspension	1.4	ch.2K-5-065001→; for OE: 1BA, 1LJ, 1ZE, A9J; <b>ST</b>	<b>F8-7834</b>		H=90; $\tau$ [mm]=2682
Rubber Buffer, suspension	1.4	for OE: 1BJ, 1LJ, 1ZE; <b>HD</b>	<b>F8-7834</b>		H=90; $\tau$ [mm]=2682

<b>F8-6569</b>	<b>F8-6570</b>	<b>F8-6572</b>	<b>F8-6988</b>	<b>F8-6989</b>	<b>F8-6991</b>	<b>F8-7132</b>
Ref.Nr.: 6N0412249C	Ref.Nr.: 1K0412331C	Ref.Nr.: 038105243L	Ref.Nr.: 1K0199262AL	Ref.Nr.: 1K0199262AM	Ref.Nr.: 1K0199262AK	Ref.Nr.: 6N0413175A
<b>F8-7174</b>	<b>F8-7679</b>	<b>F8-7703</b>	<b>F8-7798</b>	<b>F8-7831</b>	<b>F8-7832</b>	<b>F8-7834</b>
Ref.Nr.: 1K0412303M	Ref.Nr.: 2K0511155	Ref.Nr.: 1K0412303G	Ref.Nr.: 2K0511413C	Ref.Nr.: 1K0412303S	Ref.Nr.: 1K0412303P	Ref.Nr.: 1K0412303H

**Article Description**

**Article Nr.**
**Fitting Position**

<b>CADDY III Estate (2KB, 2KJ, 2CB, 2CJ)</b>			<b>03/2004 → 08/2010</b>		
Rubber Buffer, suspension	1.4 16V, 1.6, 1.9 TDI, 2.0 EcoFuel, 2.0 SDI	ch.2K-5-065001→; ch.→2K-B-005000; for OE: 1BA, 1LJ, 1ZE, A9J; <b>ST</b>	<b>F8-7834</b>		H=90; τ [mm]=2682
Rubber Buffer, suspension	1.4 16V, 1.6, 1.9 TDI, 2.0 EcoFuel, 2.0 SDI, 2.0 TDI	ch.2K-B-200001→; for OE: 1BA, A8C, A8G, A8M; <b>ST</b>	<b>F8-7834</b>		H=90; τ [mm]=2682
Rubber Buffer, suspension	1.4 16V, 1.6, 1.9 TDI, 2.0 EcoFuel, 2.0 SDI, 2.0 TDI	ch.2K-B-200001→; for OE: 1BJ, 1ZA, 1ZE, 2MK; <b>HD</b>	<b>F8-7834</b>		H=90; τ [mm]=2682
Rubber Buffer, suspension	1.4 16V, 1.6, 1.9 TDI, 2.0 EcoFuel, 2.0 TDI	ch.→2K-B-005000; for OE: 1BJ, 1LJ, 1ZE; <b>HD</b>	<b>F8-7834</b>		H=90; τ [mm]=2682
Rubber Buffer, suspension	2.0 SDI	ch.2K-B-200001→; ch.→2K-B-005000; for OE: 1BJ, 1LJ, 1ZE; <b>HD</b>	<b>F8-7834</b>		H=90; τ [mm]=2682
Rubber Buffer, suspension	2.0 TDI	ch.→2K-B-005000; for OE: 1BA, 1LJ, 1ZE, A9J; <b>ST</b>	<b>F8-7834</b>		H=90; τ [mm]=2682
Control Arm-/Trailing Arm Bush	1.2 TSI, 1.6 BiFuel, 1.6 TDI, 2.0 TDI, 2.0 TDI 16V		<b>F8-7856</b>		H=50; d=13.2; D=65
Control Arm-/Trailing Arm Bush	1.4 16V, 1.6, 1.9 TDI, 1.9 TDI 4motion, 2.0 EcoFuel, 2.0 SDI, 2.0 TDI	06/2010 →	<b>F8-7856</b>		H=50; d=13.2; D=65
Control Arm-/Trailing Arm Bush	2.0 TDI 16V 4motion, 2.0 TDI 4motion	for OE: E01; not for PR: E02; not for  [mm]: 3002; ;	<b>F8-7856</b>		H=50; d=13.2; D=65; τ [mm]=2682
Engine Mounting	1.2 TSI, 1.4, 1.4 16V, 1.6, 1.6 BiFuel		<b>F8-7960</b>		
Engine Mounting	1.9 TDI		<b>F8-7962</b>		
Engine Mounting	1.9 TDI	BLS;	<b>F8-7962</b>		
Engine Mounting	1.4, 1.4 16V, 1.6, 2.0 EcoFuel, 2.0 SDI		<b>F8-7965</b>		
Engine Mounting	1.9 TDI, 1.9 TDI 4motion, 2.0 TDI		<b>F8-7966</b>		
Engine Mounting	1.2 TSI, 1.4, 1.4 16V, 1.6, 1.6 BiFuel, 1.6 TDI, 1.9 TDI, 1.9 TDI 4motion, 2.0 EcoFuel, 2.0 SDI, 2.0 TDI, 2.0 TDI 16V, 2.0 TDI 16V 4motion, 2.0 TDI 4motion		<b>F8-7982</b>		
Engine Mounting	1.9 TDI 4motion		<b>F8-8152</b>		
Engine Mounting	2.0 TDI, 2.0 TDI 16V, 2.0 TDI 16V 4motion, 2.0 TDI 4motion	6-speed	<b>F8-8152</b>		
<b>CC (358)</b>			<b>11/2011 →</b>		
Alternator Freewheel Clutch	2.0 TDI		<b>F5-1004</b>		
Alternator Freewheel Clutch	1.8 TSI, 2.0 TSI		<b>F5-1044</b>		
Alternator Freewheel Clutch	1.4 TSI		<b>F5-1064</b>		
Alternator Freewheel Clutch	3.6 FSI 4motion		<b>F5-1085</b>		
Control Arm-/Trailing Arm Bush	1.4 TSI, 1.8 TSI, 2.0 TDI, 2.0 TDI 4motion, 2.0 TSI, 3.6 FSI 4motion		<b>F8-5633</b>		
Protective Cap/Bellow, shock absorber	1.4 TSI, 1.8 TSI, 2.0 TDI, 2.0 TDI 4motion, 2.0 TSI, 3.6 FSI 4motion		<b>F8-6044</b>		H=160
Top Strut Mounting	1.4 TSI, 1.8 TSI, 2.0 TDI, 2.0 TDI 4motion, 2.0 TSI, 3.6 FSI 4motion		<b>F8-6284</b>		
Anti-Friction Bearing	1.4 TSI, 1.8 TSI, 2.0 TDI, 2.0 TDI 4motion, 2.0 TSI, 3.6 FSI 4motion		<b>F8-6569</b>		

<b>F5-1004</b>	<b>F5-1044</b>	<b>F5-1064</b>	<b>F5-1085</b>	<b>F8-5633</b>	<b>F8-6044</b>	<b>F8-6284</b>
Ref.Nr.: 038903119T	Ref.Nr.: 06B903119B	Ref.Nr.: 03C903119D	Ref.Nr.: 045903119A	Ref.Nr.: 1K0407182A	Ref.Nr.: 3C0513425	Ref.Nr.: 6N0412249C
<b>F8-6569</b>	<b>F8-6570</b>	<b>F8-7834</b>	<b>F8-7856</b>	<b>F8-7960</b>	<b>F8-7962</b>	<b>F8-7965</b>
Ref.Nr.: 6N0412249C	Ref.Nr.: 1K0412331C	Ref.Nr.: 1K0412303H	Ref.Nr.: 5C0407183A	Ref.Nr.: 1K0199555L	Ref.Nr.: 1K0199555Q	Ref.Nr.: 1K0199855BA
<b>F8-7966</b>	<b>F8-7982</b>	<b>F8-8152</b>				
Ref.Nr.: 1K0199855BB	Ref.Nr.: 1K0199868Q	Ref.Nr.: 1K0199555T				

**Article Description****Article Nr.****Fitting Position**

<b>CC (358)</b>				<b>11/2011 →</b>	
Top Strut Mounting	1.4 TSI, 1.8 TSI, 2.0 TDI, 2.0 TDI 4motion, 2.0 TSI, 3.6 FSI 4motion		<b>F8-6570</b>		
Engine Mounting	1.8 TSI, 2.0 TSI		<b>F8-6989</b>		
Protective Cap/Bellow, shock absorber	1.4 TSI, 1.8 TSI, 2.0 TDI, 2.0 TDI 4motion, 2.0 TSI, 3.6 FSI 4motion		<b>F8-7132</b>		H=190
Top Strut Mounting	1.4 TSI, 1.8 TSI, 2.0 TDI, 2.0 TDI 4motion, 2.0 TSI, 3.6 FSI 4motion		<b>F8-7603</b>		
Engine Mounting	1.8 TSI, 2.0 TDI, 2.0 TDI 4motion, 2.0 TSI	Aluminium	<b>F8-7851</b>		
Control Arm-/Trailing Arm Bush	3.6 FSI 4motion		<b>F8-7909</b>		
Engine Mounting	1.4 TSI, 1.8 TSI, 2.0 TDI, 2.0 TDI 4motion, 2.0 TSI		<b>F8-7982</b>		
<b>CORRADO (53i)</b>				<b>09/1988 → 12/1995</b>	
Dust Cover Kit, shock absorber	All Models		<b>AK-732516</b>		
Dust Cover Kit, shock absorber	All Models		<b>AK-733023</b>		
Dust Cover Kit, shock absorber	All Models		<b>AK-735014</b>		
Control Arm-/Trailing Arm Bush	All Models	without guide sleeve	<b>F8-1007</b>		H1=26; H2=41; d=17; D1=60; D2=68
Control Arm-/Trailing Arm Bush	All Models	with guide sleeve	<b>F8-1007S</b>		H1=26; H2=41; d=17; D1=60; D2=68
Repair Kit, link	All Models	with guide sleeve	<b>F8-1008</b>		H1=24; H2=41; d=17; D=60
Top Strut Mounting	1.8 16V, 1.8 G60, 2.0 i, 2.0 i 16V		<b>F8-1009C</b>		H1=39; H2=55; d=14; D=127
Mounting, axle beam	1.8 16V, 1.8 G60, 2.0 i, 2.0 i 16V		<b>F8-1010</b>		H=90; d=12; D1=22; D2=44
Repair Set, axle beam	1.8 16V, 1.8 G60, 2.0 i, 2.0 i 16V		<b>F8-1010S</b>		
Engine Mounting	1.8 16V, 1.8 G60, 2.0 i, 2.0 i 16V		<b>F8-1025</b>		H=128; D=100; W=180
Top Strut Mounting	2.9 VR6		<b>F8-1034</b>		H=50; d=27; D=98
Top Strut Mounting	2.9 VR6		<b>F8-1034S</b>		H=51; d=14; D=96
Anti-Friction Bearing	1.8 16V, 1.8 G60, 2.0 i, 2.0 i 16V		<b>F8-3036</b>		
Anti-Friction Bearing	2.9 VR6		<b>F8-3039</b>		H=14; d1=14; D=45
Engine Mounting	1.8 16V, 1.8 G60, 2.0 i, 2.0 i 16V		<b>F8-3040</b>		H=116; D=111
Engine Mounting	2.9 VR6		<b>F8-3041</b>		H=85; D1=69; D2=71; T [mm]=106
Stabiliser Mounting	All Models		<b>F8-3042</b>		H=33; d=17; W=35
Repair Set, axle beam	2.9 VR6	with fastening material	<b>F8-4008S</b>		H1=54; H2=90; d=12; D=56
Clamp, silencer	1.8 16V, 1.8 G60, 2.0 i 16V, 2.9 VR6		<b>F8-4027</b>		H=17; W=53, 61
Rubber Buffer, suspension	1.8 16V, 1.8 G60, 2.0 i, 2.0 i 16V		<b>F8-4063</b>		H=83; d1=18; d2=25; D1=48; D2=60
Bellow, steering	All Models		<b>F8-4069</b>		
Bellow, steering	1.8 16V, 1.8 G60, 2.0 i, 2.0 i 16V		<b>F8-4075</b>		H=200; d=10; D=48
Spring Cap	1.8 16V, 1.8 G60, 2.0 i, 2.0 i 16V	ch.→50-S-000051	<b>F8-5360</b>		

<b>AK-732516</b>	<b>AK-733023</b>	<b>AK-735014</b>	<b>F8-1007</b>	<b>F8-1007S</b>	<b>F8-1008</b>	<b>F8-1009C</b>
Ref.Nr.:	Ref.Nr.: 191412303	Ref.Nr.:	Ref.Nr.: 191407181A	Ref.Nr.: 191407181A	Ref.Nr.: 191407181E	Ref.Nr.: 357412329
<b>F8-1010</b>	<b>F8-1010S</b>	<b>F8-1025</b>	<b>F8-1034</b>	<b>F8-1034S</b>	<b>F8-3036</b>	<b>F8-3039</b>
Ref.Nr.: 191501541	Ref.Nr.: 191501541	Ref.Nr.: 191199262C	Ref.Nr.: 357412331A	Ref.Nr.: 7201848S1	Ref.Nr.: 377412335A	Ref.Nr.: 357412249A
<b>F8-3040</b>	<b>F8-3041</b>	<b>F8-3042</b>	<b>F8-4008S</b>	<b>F8-4027</b>	<b>F8-4063</b>	<b>F8-4069</b>
Ref.Nr.: 357199279	Ref.Nr.: 357199402A	Ref.Nr.: 191411314	Ref.Nr.: 1H0501541	Ref.Nr.: 171253147A	Ref.Nr.: 191412303A	Ref.Nr.: 171419831B

**Article Description**

**Article Nr.**
**Fitting Position**

**CORRADO (53I)**
**09/1988 → 12/1995**

Spring Mounting	All Models		F8-5393		
Engine Mounting	2.9 VR6		F8-5400		
Top Strut Mounting	All Models		F8-5402		
Top Strut Mounting	All Models		F8-5403		
Engine Mounting	1.8 16V, 1.8 G60, 2.0 i, 2.0 i 16V		F8-5491		
Engine Mounting	All Models		F8-5554		H=39.5; d1=16; d2=24; D=50
Spring Cap	2.0 i, 2.0 i 16V, 2.9 VR6	ch.50-S-000052→	F8-5580		D=92
Rubber Buffer, suspension	1.8 16V, 1.8 G60, 2.0 i, 2.0 i 16V		F8-5594		H=146; d=10.5; D=55.6
Protective Cap/Bellow, shock absorber	All Models		F8-5747		H=90
Repair Kit, suspension strut	All Models		F8-6382		
Sleeve, control arm mounting	All Models		F8-6699		d=16; L=50; D=17
Engine Mounting	2.9 VR6		F8-6717		
Control Arm-/Trailing Arm Bush	All Models		F8-7978		
Control Arm-/Trailing Arm Bush	All Models		G9-648		H=54; d=12; D1=33; D2=36
Bellow, steering	1.8 16V	with clamps;	LM-10003S		d1=9; d2=43; L [mm]=210
Bellow, steering	1.8 G60, 2.0 i, 2.0 i 16V, 2.9 VR6	ch.50-K-000001→; with clamps;	LM-10003S		d1=9; d2=43; L [mm]=210
Bellow, steering	All Models	with clamps	LM-10006S		d1=10; d2=41; L [mm]=210

**CRAFTER 30-35 Bus (2E\_)**
**04/2006 → 07/2011**

Alternator Freewheel Clutch	2.5 TDI		F5-1004		
Alternator Freewheel Clutch	2.0 TDI, 2.0 TDI 4motion		F5-1085		
Stabiliser Mounting	2.5 TDI		F8-5752		H=26; d=12; D=26
Control Arm-/Trailing Arm Bush	2.0 TDI, 2.0 TDI 4motion, 2.5 TDI		F8-7161		
Control Arm-/Trailing Arm Bush	2.0 TDI, 2.0 TDI 4motion, 2.5 TDI		F8-7162		
Stabiliser Mounting	2.0 TDI, 2.5 TDI	for OE: 0AB; with holder	F8-8105		d=20
Stabiliser Mounting	2.0 TDI, 2.5 TDI	for OE: 0AC; with holder	F8-8106		d=23

**CRAFTER 30-50 Box (2E\_)**
**04/2006 → 07/2011**

Alternator Freewheel Clutch	2.5 TDI		F5-1004		
Alternator Freewheel Clutch	2.0 TDI, 2.0 TDI 4motion		F5-1085		
Stabiliser Mounting	2.5 TDI		F8-5752		H=26; d=12; D=26
Control Arm-/Trailing Arm Bush	2.0 TDI, 2.0 TDI 4motion, 2.5 TDI		F8-7161		
Control Arm-/Trailing Arm Bush	2.0 TDI, 2.0 TDI 4motion, 2.5 TDI		F8-7162		

<b>F5-1004</b>	<b>F5-1085</b>	<b>F8-5393</b>	<b>F8-5400</b>	<b>F8-5402</b>	<b>F8-5403</b>	<b>F8-5491</b>
Ref.Nr.: 038903119T	Ref.Nr.: 045903119A	Ref.Nr.: 1H0512149	Ref.Nr.: 1H0199262D	Ref.Nr.: 191512335	Ref.Nr.: 191512333	Ref.Nr.: 357199381
<b>F8-5554</b>	<b>F8-5580</b>	<b>F8-5594</b>	<b>F8-5747</b>	<b>F8-5752</b>	<b>F8-6382</b>	<b>F8-6699</b>
Ref.Nr.: 191199233	Ref.Nr.: 1J0412341	Ref.Nr.: 191512131B	Ref.Nr.: 191513425	Ref.Nr.: 5103955AB	Ref.Nr.: 191512333S	Ref.Nr.: 191407190A
<b>F8-6717</b>	<b>F8-7161</b>	<b>F8-7162</b>	<b>F8-7978</b>	<b>F8-8105</b>	<b>F8-8106</b>	<b>G9-648</b>
Ref.Nr.: 1H0199609D	Ref.Nr.: 2E0407523	Ref.Nr.: 2E0407523A	Ref.Nr.: 357407182F	Ref.Nr.: A9063230040	Ref.Nr.: 9063233685	Ref.Nr.: 357407182



**Article Description****Article Nr.****Fitting Position**

<b>CRAFTER 30-50 Box (2E_)</b>				<b>04/2006 → 07/2011</b>	
Stabiliser Mounting	2.0 TDI, 2.5 TDI	for OE: 0AB; with holder	<b>F8-8105</b>		d=20
Stabiliser Mounting	2.0 TDI, 2.5 TDI	for OE: 0AC; with holder	<b>F8-8106</b>		d=23
<b>CRAFTER 30-50 Platform/Chassis (2F_)</b>				<b>04/2006 → 07/2011</b>	
Alternator Freewheel Clutch	2.5 TDI		<b>F5-1004</b>		
Alternator Freewheel Clutch	2.0 TDI, 2.0 TDI 4motion		<b>F5-1085</b>		
Stabiliser Mounting	2.5 TDI		<b>F8-5752</b>		H=26; d=12; D=26
Control Arm-/Trailing Arm Bush	2.0 TDI, 2.0 TDI 4motion, 2.5 TDI		<b>F8-7161</b>		
Control Arm-/Trailing Arm Bush	2.0 TDI, 2.0 TDI 4motion, 2.5 TDI		<b>F8-7162</b>		
Stabiliser Mounting	2.0 TDI, 2.5 TDI	for OE: 0AB; with holder	<b>F8-8105</b>		d=20
Stabiliser Mounting	2.0 TDI, 2.5 TDI	for OE: 0AC; with holder	<b>F8-8106</b>		d=23
<b>DERBY (86)</b>				<b>02/1977 → 09/1981</b>	
Dust Cover Kit, shock absorber	All Models		<b>AK-735014</b>		
Dust Cover Kit, shock absorber	All Models		<b>AK-735025</b>		
Dust Cover Kit, shock absorber	0.9, 1.1, 1.3		<b>AK-735027</b>		
Flange, carburettor	0.9, 1.1, 1.3		<b>F8-4013</b>		H1=84; H2=95; d=36; T [mm]=68
Control Arm-/Trailing Arm Bush	0.9, 1.1, 1.3	ch.869-2523523→	<b>F8-4042</b>		H=44; d=10; D1=38; D2=42
Bellow, driveshaft	0.9, 1.1, 1.3		<b>F8-4080</b>		H=95; D1=29; D2=96
Bellow, steering	0.9, 1.1, 1.3	01/1980 →	<b>F8-5044</b>		
Stabiliser Mounting	0.9, 1.1, 1.3		<b>F8-5132</b>		
Stabiliser Mounting	0.9, 1.1, 1.3		<b>F8-5148</b>		d=16.5; D=125.24
Top Strut Mounting	All Models		<b>F8-5738</b>		
Mounting, axle beam	All Models		<b>F8-6232</b>		H=54; d=10; D=44
<b>DERBY (86C, 80)</b>				<b>08/1981 → 12/1984</b>	
Dust Cover Kit, shock absorber	1.0, 1.1, 1.3		<b>AK-735014</b>		
Dust Cover Kit, shock absorber	All Models		<b>AK-735025</b>		
Dust Cover Kit, shock absorber	1.0, 1.1, 1.3		<b>AK-735027</b>		
Control Arm-/Trailing Arm Bush	1.0, 1.1, 1.3		<b>F8-4042</b>		H=44; d=10; D1=38; D2=42
Bellow, steering	1.0, 1.3		<b>F8-5044</b>		
Stabiliser Mounting	1.0, 1.1, 1.3		<b>F8-5132</b>		
Stabiliser Mounting	1.0, 1.3		<b>F8-5148</b>		d=16.5; D=125.24
Top Strut Mounting	All Models		<b>F8-5738</b>		
Mounting, axle beam	1.0, 1.1, 1.3		<b>F8-6232</b>		H=54; d=10; D=44

<b>AK-735014</b>	<b>AK-735025</b>	<b>AK-735027</b>	<b>F5-1004</b>	<b>F5-1085</b>	<b>F8-4013</b>	<b>F8-4042</b>
Ref.Nr.:	Ref.Nr.:	Ref.Nr.:	Ref.Nr.: 038903119T	Ref.Nr.: 045903119A	Ref.Nr.: 052129765A	Ref.Nr.: 823407181
<b>F8-4080</b>	<b>F8-5044</b>	<b>F8-5132</b>	<b>F8-5148</b>	<b>F8-5738</b>	<b>F8-5752</b>	<b>F8-6232</b>
Ref.Nr.: 113501149	Ref.Nr.: 861419831B	Ref.Nr.: 861407183	Ref.Nr.: 861411313E	Ref.Nr.: 871412323A	Ref.Nr.: 5103955AB	Ref.Nr.: 861511271
<b>F8-7161</b>	<b>F8-7162</b>	<b>F8-7744</b>	<b>F8-8105</b>	<b>F8-8106</b>		
Ref.Nr.: 2E0407523	Ref.Nr.: 2E0407523A	Ref.Nr.: 030129765	Ref.Nr.: A9063230040	Ref.Nr.: 9063233685		

Article Description



Article Nr.

Fitting Position



DERBY (86C, 80)		08/1981 → 12/1984	
Flange, carburettor	1.0		F8-7744
EOS (1F7, 1F8)		03/2006 → 11/2010	
Dust Cover Kit, shock absorber	1.4 TSI, 2.0 TDI, 2.0 TDI 16V, 2.0 TSI, 3.6 V6	ST	AK-735095
Dust Cover Kit, shock absorber	1.6 FSI, 2.0 FSI, 2.0 TDI, 2.0 TFSI, 3.2 V6		AK-735095
Dust Cover Kit, shock absorber	1.6 FSI, 2.0 FSI, 2.0 TDI, 2.0 TFSI, 3.2 V6		AK-735175
Alternator Freewheel Clutch	2.0 FSI, 2.0 TDI, 2.0 TDI 16V, 2.0 TFSI, 3.2 V6		F5-1004
Alternator Freewheel Clutch	1.4 TSI, 2.0 TFSI, 2.0 TSI		F5-1044
Alternator Freewheel Clutch	1.4 TSI		F5-1064
Alternator Freewheel Clutch	2.0 FSI, 2.0 TFSI, 3.2 V6, 3.6 V6		F5-1085
Control Arm-/Trailing Arm Bush	1.4 TSI, 1.6 FSI, 2.0 FSI, 2.0 TDI, 2.0 TDI 16V, 2.0 TFSI, 2.0 TSI, 3.2 V6, 3.6 V6		F8-5633
Belt Pulley, crankshaft	2.0 FSI		F8-5650
Protective Cap/Bellow, shock absorber	1.4 TSI, 2.0 TDI, 2.0 TDI 16V, 2.0 TFSI, 2.0 TSI, 3.2 V6, 3.6 V6	⚙️	F8-6044
Top Strut Mounting	1.4 TSI, 1.6 FSI, 2.0 FSI, 2.0 TDI, 2.0 TDI 16V, 2.0 TFSI, 2.0 TSI, 3.2 V6, 3.6 V6	⚙️	F8-6284
Belt Pulley, crankshaft	2.0 TDI	Number of Ribs: 5; Parameter: 6PK	F8-6396
Control Arm-/Trailing Arm Bush	1.4 TSI, 1.6 FSI, 2.0 FSI, 2.0 TDI, 2.0 TFSI, 2.0 TSI, 3.2 V6, 3.6 V6	Aluminium	F8-6424
Control Arm-/Trailing Arm Bush	1.4 TSI, 1.6 FSI, 2.0 FSI, 2.0 TDI, 2.0 TFSI, 2.0 TSI, 3.2 V6, 3.6 V6	Aluminium	F8-6425
Control Arm-/Trailing Arm Bush	1.4 TSI, 1.6 FSI, 2.0 FSI, 2.0 TDI, 2.0 TFSI, 2.0 TSI, 3.2 V6, 3.6 V6		F8-6463
Engine Mounting	2.0 TDI		F8-6528
Anti-Friction Bearing	1.4 TSI, 1.6 FSI, 2.0 FSI, 2.0 TDI, 2.0 TDI 16V, 2.0 TFSI, 2.0 TSI, 3.2 V6, 3.6 V6		F8-6569
Top Strut Mounting	1.4 TSI, 1.6 FSI, 2.0 FSI, 2.0 TDI, 2.0 TDI 16V, 2.0 TFSI, 2.0 TSI, 3.2 V6, 3.6 V6	⚙️	F8-6570
Belt Pulley, crankshaft	2.0 TDI	Number of Ribs: 5; Parameter: 6PK	F8-6572
Belt Pulley, crankshaft	2.0 TDI 16V	⚙️ CFFB; Number of Ribs: 5; Parameter: 6PK	F8-6572
Control Arm-/Trailing Arm Bush	1.4 TSI, 1.6 FSI, 2.0 FSI, 2.0 TDI, 2.0 TFSI, 2.0 TSI, 3.2 V6, 3.6 V6		F8-6736
Engine Mounting	2.0 FSI, 2.0 TFSI, 2.0 TSI		F8-6989
Engine Mounting	1.6 FSI		F8-6991
Engine Mounting	3.2 V6		F8-7008
Rubber Buffer, suspension	1.4 TSI, 1.6 FSI, 2.0 FSI, 2.0 TFSI, 2.0 TSI, 3.2 V6, 3.6 V6	for OE: 2UA, 2UE; ⚙️, ST	F8-7131
Rubber Buffer, suspension	2.0 TDI 16V	for OE: 2UA, 2UE; ST	F8-7131

<b>AK-735095</b>	<b>AK-735175</b>	<b>F5-1004</b>	<b>F5-1044</b>	<b>F5-1064</b>	<b>F5-1085</b>	<b>F8-5633</b>
Ref.Nr.: 1J0512131B	Ref.Nr.: 1K0412303B	Ref.Nr.: 038903119T	Ref.Nr.: 06B903119B	Ref.Nr.: 03C903119D	Ref.Nr.: 045903119A	Ref.Nr.: 1K0407182A
<b>F8-5650</b>	<b>F8-6044</b>	<b>F8-6284</b>	<b>F8-6396</b>	<b>F8-6424</b>	<b>F8-6425</b>	<b>F8-6463</b>
Ref.Nr.: 06A105243E	Ref.Nr.: 3C0513425	Ref.Nr.: 6N0412249C	Ref.Nr.: 03G105243	Ref.Nr.: 1K0199232G	Ref.Nr.: 1K0199231J	Ref.Nr.: 1K0505541B
<b>F8-6528</b>	<b>F8-6569</b>	<b>F8-6570</b>	<b>F8-6572</b>	<b>F8-6736</b>	<b>F8-6989</b>	<b>F8-6991</b>
Ref.Nr.: 1K0 199 262 AT	Ref.Nr.: 6N0412249C	Ref.Nr.: 1K0412331C	Ref.Nr.: 038105243L	Ref.Nr.: 1K0407183A	Ref.Nr.: 1K0199262AM	Ref.Nr.: 1K0199262AK

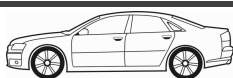
**Article Description****Article Nr.****Fitting Position****EOS (1F7, 1F8) 03/2006 → 11/2010**

Rubber Buffer, suspension	2.0 TDI, 2.0 TDI 16V	for OE: 2UA; <b>ST</b>	<b>F8-7131</b>		H=70
Protective Cap/Bellow, shock absorber	1.4 TSI, 1.6 FSI, 2.0 FSI, 2.0 TDI, 2.0 TDI 16V, 2.0 TFSI, 2.0 TSI, 3.2 V6, 3.6 V6		<b>F8-7132</b>		H=190
Rubber Buffer, suspension	1.4 TSI, 1.6 FSI, 2.0 FSI, 2.0 TDI, 2.0 TDI 16V, 2.0 TFSI, 2.0 TSI, 3.2 V6, 3.6 V6	for OE: 1JA, 1JR; <b>ST</b>	<b>F8-7576</b>		H=133
Rubber Buffer, suspension	1.4 TSI, 1.6 FSI, 2.0 FSI, 2.0 TDI, 2.0 TDI 16V, 2.0 TFSI, 2.0 TSI, 3.2 V6, 3.6 V6	for OE: 1JC, 1JK; Shape Round; <b>SP</b>	<b>F8-7601</b>		H=118
Protective Cap/Bellow, shock absorber	All Models	for OE: 1JT; <b>SP</b>	<b>F8-7627</b>		H=178
Protective Cap/Bellow, shock absorber	1.4 TSI, 1.6 FSI, 2.0 FSI, 2.0 TDI, 2.0 TDI 16V, 2.0 TFSI, 2.0 TSI, 3.2 V6, 3.6 V6	for OE: 1JA, 1JC, 1JK, 1JR, 1JS; <b>SP, ST</b>	<b>F8-7640</b>		H=176
Rubber Buffer, suspension	1.4 TSI, 1.6 FSI, 2.0 FSI, 2.0 TDI, 2.0 TDI 16V, 2.0 TFSI, 2.0 TSI, 3.2 V6, 3.6 V6	for OE: 2UC, G07; <b>SP</b>	<b>F8-7697</b>		H=55
Rubber Buffer, suspension	1.4 TSI, 1.6 FSI, 2.0 FSI, 2.0 TDI, 2.0 TDI 16V, 2.0 TFSI, 2.0 TSI, 3.2 V6, 3.6 V6		<b>F8-7809</b>		H=55
Belt Pulley, crankshaft	2.0 TDI, 2.0 TDI 16V, 2.0 TFSI, 2.0 TSI	Number of Ribs: 5; Parameter: 6PK	<b>F8-7880</b>		D=143
Control Arm-/Trailing Arm Bush	1.4 TSI, 1.6 FSI, 2.0 FSI, 2.0 TDI, 2.0 TDI 16V, 2.0 TFSI, 2.0 TSI, 3.2 V6, 3.6 V6		<b>F8-7902</b>		H=60; d=12; D=42
Control Arm-/Trailing Arm Bush	1.4 TSI, 1.6 FSI, 2.0 FSI, 2.0 TDI, 2.0 TDI 16V, 2.0 TFSI, 2.0 TSI, 3.2 V6, 3.6 V6		<b>F8-7907</b>		H=45; d=14; D=38
Control Arm-/Trailing Arm Bush	1.4 TSI, 1.6 FSI, 2.0 FSI, 2.0 TDI, 2.0 TDI 16V, 2.0 TFSI, 2.0 TSI, 3.2 V6, 3.6 V6		<b>F8-7908</b>		H=45; d=12; D=38
Engine Mounting	1.4 TSI, 1.6 FSI		<b>F8-7960</b>		
Engine Mounting	2.0 FSI, 2.0 TDI, 2.0 TFSI		<b>F8-7966</b>		
Engine Mounting	1.6 FSI, 2.0 FSI		<b>F8-7981</b>		
Engine Mounting	2.0 TDI	ch.→1F-8-045000	<b>F8-7981</b>		
Engine Mounting	2.0 TFSI	BPY, BWA	<b>F8-7981</b>		
Engine Mounting	1.4 TSI, 1.6 FSI, 2.0 TDI, 2.0 TDI 16V, 2.0 TFSI, 2.0 TSI		<b>F8-7982</b>		
Engine Mounting	2.0 FSI	BVZ	<b>F8-7982</b>		

**FOX (5Z1, 5Z3) 10/2003 →**

Dust Cover Kit, shock absorber	All Models	<b>ST</b>	<b>AK-735410</b>		H=210
Alternator Freewheel Clutch	1.2		<b>F5-1000</b>		
Alternator Freewheel Clutch	1.4 TDI		<b>F5-1004</b>		
Alternator Freewheel Clutch	1.4 TDI		<b>F5-1085</b>		
Anti-Friction Bearing	All Models	for OE: G25, G26	<b>F8-3039</b>		H=14; d1=14; D=45
Top Strut Mounting	All Models		<b>F8-5380</b>		
Rubber Buffer, suspension	All Models		<b>F8-5381</b>		H=37; D=76
Engine Mounting	1.4		<b>F8-5534</b>		

<b>AK-735410</b>	<b>F5-1000</b>	<b>F5-1004</b>	<b>F5-1085</b>	<b>F8-3039</b>	<b>F8-5380</b>	<b>F8-5381</b>
Ref.Nr.: 1J0412303	Ref.Nr.: 03D903119A	Ref.Nr.: 038903119T	Ref.Nr.: 045903119A	Ref.Nr.: 357412249A	Ref.Nr.: 1J0513353G	Ref.Nr.: 1J0512149B
<b>F8-5534</b>	<b>F8-5683</b>	<b>F8-7131</b>	<b>F8-7132</b>	<b>F8-7576</b>	<b>F8-7601</b>	<b>F8-7627</b>
Ref.Nr.: 6Q0199851AB	Ref.Nr.: 357413175A	Ref.Nr.: 1K0412303B	Ref.Nr.: 6N0413175A	Ref.Nr.: 1K0 511 353 M	Ref.Nr.: 1K0511353N	Ref.Nr.: 1K0513425D
<b>F8-7640</b>	<b>F8-7697</b>	<b>F8-7809</b>	<b>F8-7880</b>	<b>F8-7902</b>	<b>F8-7907</b>	<b>F8-7908</b>
Ref.Nr.: 1K0513425A	Ref.Nr.: 1K0412303F	Ref.Nr.: 1K0412303E	Ref.Nr.: 06H105243F	Ref.Nr.: 1K0505171C	Ref.Nr.: 1K0505203A	Ref.Nr.: 1K0505279A

Article Description



Article Nr.

Fitting Position



**FOX (5Z1, 5Z3)**

10/2003 →

Protective Cap/Bellow, shock absorber	All Models		<b>F8-5683</b>		H=210
Rubber Buffer, suspension	All Models	for OE: G25	<b>F8-5996</b>		H=63
Rubber Buffer, suspension	All Models	for OE: G26	<b>F8-6041</b>		H=53
Protective Cap/Bellow, shock absorber	All Models		<b>F8-6044</b>		H=160
Stabiliser Mounting	1.2, 1.4, 1.4 TDI		<b>F8-6461</b>		d=17
Stabiliser Mounting	1.2, 1.4, 1.4 TDI	Stabi. Diam. [mm]= 18	<b>F8-6462</b>		d=16
Engine Mounting	1.2		<b>F8-6532</b>		
Engine Mounting	1.4 TDI		<b>F8-6533</b>		
Anti-Friction Bearing	All Models	for OE: G09, G10	<b>F8-6569</b>		
Rubber Buffer, suspension	All Models		<b>F8-6723</b>		H=124
Control Arm-/Trailing Arm Bush	1.2, 1.4, 1.4 TDI		<b>F8-6736</b>		
Engine Mounting	1.4		<b>F8-6986</b>		
Protective Cap/Bellow, shock absorber	All Models		<b>F8-7132</b>		H=190
Rubber Buffer, suspension	1.2, 1.4, 1.4 TDI	for OE: G09, G18, G26	<b>F8-7675</b>		H=84
Control Arm-/Trailing Arm Bush	All Models		<b>F8-7873</b>		
Engine Mounting	1.4		<b>F8-7949</b>		
Engine Mounting	1.4 TDI		<b>F8-7950</b>		
Engine Mounting	1.2		<b>F8-7951</b>		
Engine Mounting	1.4 TDI		<b>F8-7952</b>		
Engine Mounting	1.2		<b>F8-7955</b>		
Belt Pulley, crankshaft	1.4 TDI	Number of Ribs: 5; Parameter: 6PK	<b>F8-8038</b>		
Engine Mounting	1.4, 1.4 TDI, 1.6, 1.6 Total Flex		<b>F8-8164</b>		

**GOL II**

04/1998 → 05/2002

Alternator Freewheel Clutch	1.9 D		<b>F5-1024</b>		
-----------------------------	-------	--	----------------	--	--

**GOLF (17)**

04/1974 → 07/1985

Dust Cover Kit, shock absorber	1.1, 1.3, 1.5, 1.5 D, 1.6, 1.6 D, 1.6 GTI, 1.6 TD, 1.8 GTI		<b>AK-733023</b>		
Dust Cover Kit, shock absorber	1.1, 1.3, 1.5, 1.5 D, 1.6, 1.6 D, 1.6 GTI, 1.6 TD, 1.8 GTI		<b>AK-735006</b>		
Dust Cover Kit, shock absorber	1.6		<b>AK-735014</b>		
Engine Mounting	1.5 D	Engine001001→	<b>F8-1001</b>		H1=42; H2=61; d=11; D=74.5
Engine Mounting	1.5, 1.6 GTI		<b>F8-1001</b>		H1=42; H2=61; d=11; D=74.5
Engine Mounting	1.6 D, 1.6 TD		<b>F8-1001</b>		H1=42; H2=61; d=11; D=74.5
Top Strut Mounting	1.1, 1.3, 1.5, 1.6 D, 1.6 TD, 1.8 GTI	ch.1773551889→; with slide bearing	<b>F8-1002</b>		

<b>AK-733023</b>	<b>AK-735006</b>	<b>AK-735014</b>	<b>F5-1024</b>	<b>F8-1001</b>	<b>F8-1002</b>	<b>F8-5683</b>
Ref.Nr.: 191412303	Ref.Nr.:	Ref.Nr.:	Ref.Nr.: 028903119AJ	Ref.Nr.: 171199214K	Ref.Nr.: 171412329A	Ref.Nr.: 357413175A
<b>F8-5996</b>	<b>F8-6041</b>	<b>F8-6044</b>	<b>F8-6461</b>	<b>F8-6462</b>	<b>F8-6532</b>	<b>F8-6533</b>
Ref.Nr.: 1H0412303B	Ref.Nr.: 1J0412303	Ref.Nr.: 3C0513425	Ref.Nr.: 6Q0 411 314 M	Ref.Nr.: 6Q0411314L	Ref.Nr.: 6Q0 199 167 BC	Ref.Nr.: 6Q0 199 167 CA
<b>F8-6569</b>	<b>F8-6723</b>	<b>F8-6736</b>	<b>F8-6986</b>	<b>F8-7132</b>	<b>F8-7675</b>	<b>F8-7873</b>
Ref.Nr.: 6N0412249C	Ref.Nr.: 6Q0512131B	Ref.Nr.: 1K0407183A	Ref.Nr.: 6Q0199167J	Ref.Nr.: 6N0413175A	Ref.Nr.: 6Q0412301	Ref.Nr.: 6Q0407182A

**Article Description****Article Nr.****Fitting Position**

<b>GOLF (17)</b>			<b>04/1974 → 07/1985</b>	
Top Strut Mounting	1.1, 1.5	with slide bearing	<b>F8-1002</b>	
Top Strut Mounting	1.1, 1.5 D, 1.6, 1.6 GTI	ch.1773551889→; 01/1977 →; with slide bearing	<b>F8-1002</b>	
Anti-Friction Bearing	1.1, 1.3, 1.5, 1.5 D, 1.6, 1.6 D, 1.6 GTI, 1.6 TD, 1.8 GTI		<b>F8-3036</b>	
Flange, carburettor	1.3		<b>F8-4013</b>	
Rubber Buffer, silencer	1.3, 1.5 D, 1.6 D, 1.6 GTI, 1.6 TD, 1.8 GTI		<b>F8-4026</b>	
Clamp, silencer	1.1, 1.3, 1.5, 1.5 D, 1.6, 1.6 D, 1.6 GTI, 1.6 TD, 1.8 GTI		<b>F8-4027</b>	
Protective Cap/Bellow, shock absorber	1.1, 1.3, 1.5, 1.6 D, 1.6 TD, 1.8 GTI	ch.1773551889→	<b>F8-4064</b>	
Protective Cap/Bellow, shock absorber	1.1, 1.5 D, 1.6, 1.6 GTI	ch.1773551889→; 01/1977 →	<b>F8-4064</b>	
Bellow Set, steering	1.1, 1.3, 1.5, 1.5 D, 1.6, 1.6 D, 1.6 GTI, 1.6 TD, 1.8 GTI	for OE: 171419832A	<b>F8-4074</b>	
Bellow, steering	1.8 GTI		<b>F8-4075</b>	
Bellow, driveshaft	1.5, 1.5 D, 1.6, 1.6 D, 1.6 GTI, 1.6 TD, 1.8 GTI		<b>F8-4080</b>	
Stabiliser Mounting	1.6 GTI, 1.8 GTI		<b>F8-5146</b>	
Stabiliser Mounting	1.6 GTI, 1.8 GTI		<b>F8-5147</b>	
Rubber Buffer, suspension	1.1, 1.3, 1.5, 1.5 D, 1.6, 1.6 D, 1.6 GTI, 1.6 TD, 1.8 GTI		<b>F8-5755</b>	
Bellow, driveshaft	1.1, 1.6 GTI	ch.17A0360001→; 01/1980 →	<b>F8-7722</b>	
Bellow, driveshaft	1.3, 1.5, 1.6 D, 1.6 TD, 1.8 GTI		<b>F8-7722</b>	
Bellow, driveshaft	1.5 D	ch.17A0116213→; 01/1980 →	<b>F8-7722</b>	
Bellow, driveshaft	1.6	01/1980 →;  EM	<b>F8-7722</b>	
Bellow, driveshaft	1.6	01/1980 →;  FN	<b>F8-7722</b>	
Bellow, driveshaft	1.6	HN	<b>F8-7722</b>	
Control Arm-/Trailing Arm Bush	1.1, 1.3, 1.5, 1.5 D, 1.6, 1.6 D, 1.6 GTI, 1.6 TD, 1.8 GTI		<b>G9-540</b>	
Control Arm-/Trailing Arm Bush	1.1, 1.3, 1.5, 1.5 D, 1.6, 1.6 D, 1.6 GTI, 1.6 TD, 1.8 GTI		<b>G9-541</b>	
Bellow, steering	1.1, 1.3, 1.5, 1.5 D, 1.6, 1.6 D, 1.6 GTI, 1.6 TD, 1.8 GTI	with clamps;	<b>LM-10003S</b>	
Bellow, steering	1.1, 1.3, 1.5, 1.5 D, 1.6, 1.6 D, 1.6 GTI, 1.6 TD, 1.8 GTI	with clamps;	<b>LM-10003S</b>	
Bellow, steering	1.1, 1.3, 1.5, 1.5 D, 1.6, 1.6 D, 1.6 GTI, 1.6 TD, 1.8 GTI	with clamps	<b>LM-10006S</b>	
Bellow, steering	1.1, 1.3, 1.5, 1.5 D, 1.6, 1.6 D, 1.6 GTI, 1.6 TD, 1.8 GTI	with clamps;	<b>LM-10024S</b>	
Bellow, steering	1.1, 1.3, 1.5, 1.5 D, 1.6, 1.6 D, 1.6 GTI, 1.6 TD, 1.8 GTI	with clamps;	<b>LM-10050S</b>	
Bellow, steering	1.1, 1.3, 1.5, 1.5 D, 1.6, 1.6 D, 1.6 GTI, 1.6 TD, 1.8 GTI	with clamps	<b>LM-10064S</b>	
Bellow, steering	1.6	HN; with clamps	<b>LM-10064S</b>	
Bellow, driveshaft	1.1, 1.3, 1.5, 1.5 D, 1.6, 1.6 D, 1.6 GTI, 1.6 TD, 1.8 GTI		<b>M-830220</b>	
Bellow Set, drive shaft	1.1, 1.6 GTI	ch.17A0360001→	<b>MK-830220</b>	
Bellow Set, drive shaft	1.3, 1.5, 1.6 D, 1.6 TD, 1.8 GTI		<b>MK-830220</b>	



Article Description



Article Nr.

Fitting Position



<b>GOLF (17)</b>			<b>04/1974 → 07/1985</b>		
Bellow Set, drive shaft	1.5 D	ch.17A0116213→	<b>MK-830220</b>		
Bellow Set, drive shaft	1.6	EM, FN	<b>MK-830220</b>		
Bellow Set, drive shaft	1.6	HN	<b>MK-830220</b>		
Bellow Set, drive shaft	1.3, 1.5, 1.6 TD		<b>MK-830220S</b>		
<b>GOLF Convertible (155)</b>			<b>01/1979 → 04/1993</b>		
Dust Cover Kit, shock absorber	1.5, 1.6, 1.8		<b>AK-733023</b>	⊕ ⊕ ⊕	
Dust Cover Kit, shock absorber	1.5, 1.6, 1.8		<b>AK-735006</b>	⊕ ⊕ ⊕	
Engine Mounting	1.5, 1.6	ch.15A0800001→	<b>F8-1001</b>		H1=42; H2=61; d=11; D=74.5
Engine Mounting	1.6, 1.8	ch.→15-J-027000	<b>F8-1001</b>		H1=42; H2=61; d=11; D=74.5
Top Strut Mounting	1.5, 1.6, 1.8	with slide bearing	<b>F8-1002</b>	⊕ ⊕ ⊕	
Top Strut Mounting	1.8	DX; with slide bearing	<b>F8-1002</b>	⊕ ⊕ ⊕	
Anti-Friction Bearing	1.5, 1.6, 1.8		<b>F8-3036</b>	⊕ ⊕ ⊕	
Flange, carburettor	1.6		<b>F8-3044</b>		H=21
Flange, carburettor	1.6, 1.8	01/1984 →	<b>F8-3044</b>		H=21
Rubber Buffer, silencer	1.6, 1.8		<b>F8-4026</b>		H=12; W=57, 60
Clamp, silencer	1.5, 1.6, 1.8		<b>F8-4027</b>		H=17; W=53, 61
Protective Cap/Bellow, shock absorber	1.5, 1.6, 1.8		<b>F8-4064</b>		H=90; d1=50; d2=71; D1=66; D2=77
Bellow Set, steering	1.5, 1.6, 1.8		<b>F8-4074</b>	⊕	H=125; D1=34; D2=39
Bellow, steering	1.6, 1.8		<b>F8-4075</b>	⊕ ⊕ ⊕	H=200; d=10; D=48
Stabiliser Mounting	1.5, 1.6, 1.8		<b>F8-5146</b>	⊕ ⊕ ⊕	D=15
Stabiliser Mounting	1.5, 1.6, 1.8		<b>F8-5147</b>		D=15
Rubber Buffer, suspension	1.3, 1.5, 1.6, 1.8		<b>F8-5755</b>	⊕ ⊕ ⊕	
Bellow, driveshaft	1.3	ch.→15-G-035000	<b>F8-7722</b>	⊕ ⊕ ⊕	d1=26; d2=78; L=110
Bellow, driveshaft	1.5, 1.6	ch.15A0807001→	<b>F8-7722</b>	⊕ ⊕ ⊕	d1=26; d2=78; L=110
Bellow, driveshaft	1.6	ch.15A0807001→;	<b>F8-7722</b>	⊕ ⊕ ⊕	d1=26; d2=78; L=110
Bellow, driveshaft	1.6	ch.15-E-006507→;	<b>F8-7722</b>	⊕ ⊕ ⊕	d1=26; d2=78; L=110
Bellow, driveshaft	1.6		<b>F8-7722</b>	⊕ ⊕ ⊕	d1=26; d2=78; L=110
Bellow, driveshaft	1.8	ch.→15-E-035000;	<b>F8-7722</b>	⊕ ⊕ ⊕	d1=26; d2=78; L=110
Bellow, driveshaft	1.8	ch.→15-E-035000;  DX;	<b>F8-7722</b>	⊕ ⊕ ⊕	d1=26; d2=78; L=110
Bellow, driveshaft	1.8	ch.→15-J-001799;	<b>F8-7722</b>	⊕ ⊕ ⊕	d1=26; d2=78; L=110
Bellow, driveshaft	1.8	ch.15-E-006507→; ch.→15-K-035000;	<b>F8-7722</b>	⊕ ⊕ ⊕	d1=26; d2=78; L=110
Control Arm-/Trailing Arm Bush	1.5, 1.6, 1.8		<b>G9-540</b>	⊕ ⊕ ⊕	H=55; d=16; D=38

<b>AK-733023</b>	<b>AK-735006</b>	<b>F8-1001</b>	<b>F8-1002</b>	<b>F8-3036</b>	<b>F8-3044</b>	<b>F8-4026</b>
Ref.Nr.: 191412303	Ref.Nr.:	Ref.Nr.: 171199214K	Ref.Nr.: 171412329A	Ref.Nr.: 377412335A	Ref.Nr.: 026129761A	Ref.Nr.: 817253147
<b>F8-4027</b>	<b>F8-4064</b>	<b>F8-4074</b>	<b>F8-4075</b>	<b>F8-5146</b>	<b>F8-5147</b>	<b>F8-5755</b>
Ref.Nr.: 171253147A	Ref.Nr.: 191412135	Ref.Nr.: 171419832A	Ref.Nr.: 357422831	Ref.Nr.: 171411314A	Ref.Nr.: 171411313	Ref.Nr.: 171412303C
<b>F8-7722</b>	<b>G9-540</b>	<b>G9-541</b>	<b>MK-830220</b>	<b>MK-830220S</b>		
Ref.Nr.: 191407285F	Ref.Nr.: 171407181A	Ref.Nr.: 171407182D	Ref.Nr.: 171498203	Ref.Nr.:		

**Article Description****Article Nr.****Fitting Position****GOLF Convertible (155) 01/1979 → 04/1993**

Control Arm-/Trailing Arm Bush	1.5, 1.6, 1.8		<b>G9-541</b>		H=62; d=12; D=34
Bellow, steering	1.5, 1.6, 1.8	with clamps;	<b>LM-10003S</b>		d1=9; d2=43; L [mm]=210
Bellow, steering	1.6	ch.→19-E-300001→; ch.→19-G-990000; with clamps;	<b>LM-10003S</b>		d1=9; d2=43; L [mm]=210
Bellow, steering	1.6, 1.8	ch.→1G-K-990000; with clamps;	<b>LM-10003S</b>		d1=9; d2=43; L [mm]=210
Bellow, steering	1.8	ch.19-E-300001→; ch.→1G-K-990000; with clamps;	<b>LM-10003S</b>		d1=9; d2=43; L [mm]=210
Bellow, steering	1.5, 1.6, 1.8	with clamps	<b>LM-10006S</b>		d1=10; d2=41; L [mm]=210
Bellow, steering	1.5, 1.6, 1.8	with clamps;	<b>LM-10024S</b>		d1=25; d2=41; L [mm]=120
Bellow, steering	1.5, 1.6, 1.8	with clamps;	<b>LM-10050S</b>		d1=25; d2=39; L [mm]=126
Bellow, steering	1.3, 1.5, 1.6, 1.8	with clamps	<b>LM-10064S</b>		d1=25; d2=35; L [mm]=144
Bellow, steering	1.8	DX; with clamps	<b>LM-10064S</b>		d1=25; d2=35; L [mm]=144
Bellow, driveshaft	1.5, 1.6, 1.8		<b>M-830220</b>		
Bellow Set, drive shaft	1.5, 1.6	ch.15A0807001→	<b>MK-830220</b>		
Bellow Set, drive shaft	1.6	ch.15-E-006507→;	<b>MK-830220</b>		
Bellow Set, drive shaft	1.8	ch.→15-E-035000;  DX;	<b>MK-830220</b>		
Bellow Set, drive shaft	1.8	ch.15-E-006507→; ch.→15-E-035000;	<b>MK-830220</b>		
Bellow Set, drive shaft	1.8	ch.15-E-006507→; ch.→15-J-001799;	<b>MK-830220</b>		

**GOLF Mk II (19E, 1G1) 08/1983 → 12/1992**

Dust Cover Kit, shock absorber	1.0, 1.3, 1.3 CAT, 1.6, 1.6 D, 1.6 TD, 1.8, 1.8 GTI, 1.8 GTI 16V, 1.8 GTI CAT, 1.8 GTI G60, 1.8 GTI G60 Syncro, 1.8 i CAT, 1.8 i Syncro CAT, 1.8 Syncro		<b>AK-732516</b>		
Dust Cover Kit, shock absorber	1.0, 1.3, 1.3 CAT, 1.6, 1.6 D, 1.6 TD, 1.8, 1.8 GTI, 1.8 GTI 16V, 1.8 GTI CAT, 1.8 GTI G60, 1.8 GTI G60 Syncro, 1.8 i CAT, 1.8 i Syncro CAT, 1.8 Syncro		<b>AK-733023</b>		
Engine Mounting	1.0, 1.3, 1.3 CAT, 1.6, 1.6 D, 1.6 TD, 1.8, 1.8 GTI, 1.8 GTI CAT, 1.8 i CAT, 1.8 Syncro		<b>F8-1003</b>		H=120; d=11; D=106; Thick. [mm]=62, 76
Engine Mounting	1.8 GTI 16V	ch.→16-JB125000, 16-JW400000, 19-JB125000, 19-JW400000	<b>F8-1003</b>		H=120; d=11; D=106; Thick. [mm]=62, 76
Engine Mounting	1.0, 1.3, 1.6 D, 1.6 TD, 1.8 GTI G60 Syncro, 1.8 i Syncro CAT, 1.8 Syncro		<b>F8-1004</b>		H=114; D=106
Engine Mounting	1.8 GTI	ch.→19-H-990000;  EV	<b>F8-1004</b>		H=114; D=106
Engine Mounting	1.8, 1.8 GTI, 1.8 GTI 16V	ch.→19-H-990000	<b>F8-1004</b>		H=114; D=106
Engine Mounting	1.0, 1.3, 1.3 CAT, 1.8 Syncro		<b>F8-1005</b>		H=109; d1=6; d2=12; D=116
Engine Mounting	1.6, 1.8, 1.8 GTI CAT, 1.8 i CAT		<b>F8-1005</b>		H=109; d1=6; d2=12; D=116
Engine Mounting	1.8 GTI	01/1987 →	<b>F8-1005</b>		H=109; d1=6; d2=12; D=116
Engine Mounting	1.8 GTI 16V	01/1988 →	<b>F8-1005</b>		H=109; d1=6; d2=12; D=116

<b>AK-732516</b>	<b>AK-733023</b>	<b>F8-1003</b>	<b>F8-1004</b>	<b>F8-1005</b>	<b>F8-1006</b>	<b>G9-541</b>
Ref.Nr.:	Ref.Nr.: 191412303	Ref.Nr.: 191199262A	Ref.Nr.: 357199279C	Ref.Nr.: 191199279E	Ref.Nr.: 191199402B	Ref.Nr.: 171407182D
<b>LM-10003S</b>	<b>LM-10006S</b>	<b>LM-10024S</b>	<b>LM-10050S</b>	<b>LM-10064S</b>	<b>M-830220</b>	<b>MK-830220</b>
Ref.Nr.: 357422831A	Ref.Nr.: 1H0422831B	Ref.Nr.: 171419831B	Ref.Nr.: 171419831C	Ref.Nr.: 171419832C	Ref.Nr.: 191498203C	Ref.Nr.: 171498203

Article Description



Article Nr.

Fitting Position



<b>GOLF Mk II (19E, 1G1)</b>		<b>08/1983 → 12/1992</b>		
Engine Mounting	1.6, 1.6 D, 1.6 TD, 1.8, 1.8 GTI, 1.8 GTI 16V, 1.8 GTI CAT, 1.8 i CAT	ch.16-E-300001, 19-E-300001→	<b>F8-1006</b>	H=86; D1=45; D2=71; T [mm]=105
Control Arm-/Trailing Arm Bush	1.0, 1.3, 1.3 CAT, 1.6, 1.6 D, 1.6 TD, 1.8, 1.8 GTI, 1.8 GTI 16V, 1.8 GTI CAT, 1.8 GTI G60, 1.8 GTI G60 Syncro, 1.8 i CAT, 1.8 Syncro	without guide sleeve	<b>F8-1007</b>	H1=26; H2=41; d=17; D1=60; D2=68
Control Arm-/Trailing Arm Bush	1.0, 1.3, 1.3 CAT, 1.6, 1.6 D, 1.6 TD, 1.8, 1.8 GTI, 1.8 GTI 16V, 1.8 GTI CAT, 1.8 GTI G60, 1.8 GTI G60 Syncro, 1.8 i CAT, 1.8 Syncro	with guide sleeve	<b>F8-1007S</b>	H1=26; H2=41; d=17; D1=60; D2=68
Repair Kit, link	1.0, 1.3, 1.3 CAT, 1.6, 1.6 D, 1.6 TD, 1.8, 1.8 GTI, 1.8 GTI 16V, 1.8 GTI CAT, 1.8 GTI G60, 1.8 GTI G60 Syncro, 1.8 i CAT, 1.8 i Syncro CAT, 1.8 Syncro	with guide sleeve	<b>F8-1008</b>	H1=24; H2=41; d=17; D=60
Top Strut Mounting	1.0, 1.3, 1.3 CAT, 1.6, 1.6 D, 1.6 TD, 1.8, 1.8 GTI, 1.8 GTI 16V, 1.8 GTI CAT, 1.8 i CAT, 1.8 Syncro		<b>F8-1009B</b>	d=14; D=132
Top Strut Mounting	1.8 GTI G60, 1.8 GTI G60 Syncro	ch.→1G-N-300000	<b>F8-1009C</b>	H1=39; H2=55; d=14; D=127
Top Strut Mounting	1.8 Syncro	ch.1G-LB025601, 1G-LW150001→	<b>F8-1009C</b>	H1=39; H2=55; d=14; D=127
Mounting, axle beam	1.0, 1.3, 1.3 CAT, 1.6, 1.6 D, 1.6 TD, 1.8, 1.8 GTI, 1.8 GTI 16V, 1.8 GTI CAT, 1.8 GTI G60, 1.8 GTI G60 Syncro, 1.8 i CAT, 1.8 i Syncro CAT, 1.8 Syncro		<b>F8-1010</b>	H=90; d=12; D1=22; D2=44
Repair Set, axle beam	1.0, 1.3, 1.3 CAT, 1.6, 1.6 D, 1.6 TD, 1.8, 1.8 GTI, 1.8 GTI 16V, 1.8 GTI CAT, 1.8 GTI G60, 1.8 GTI G60 Syncro, 1.8 i CAT, 1.8 i Syncro CAT, 1.8 Syncro		<b>F8-1010S</b>	
Engine Mounting	1.8 GTI 16V, 1.8 GTI G60		<b>F8-1025</b>	H=128; D=100; W=180
Anti-Friction Bearing	1.0, 1.3, 1.3 CAT, 1.6, 1.6 D, 1.6 TD, 1.8, 1.8 GTI, 1.8 GTI 16V, 1.8 GTI CAT, 1.8 GTI G60, 1.8 GTI G60 Syncro, 1.8 i CAT, 1.8 i Syncro CAT, 1.8 Syncro		<b>F8-3036</b>	
Engine Mounting	1.8 GTI 16V, 1.8 GTI G60		<b>F8-3040</b>	H=116; D=111
Stabiliser Mounting	1.0, 1.3, 1.3 CAT, 1.6, 1.6 D, 1.6 TD, 1.8, 1.8 GTI, 1.8 GTI 16V, 1.8 GTI CAT, 1.8 GTI G60, 1.8 GTI G60 Syncro, 1.8 i CAT, 1.8 Syncro		<b>F8-3042</b>	H=33; d=17; W=35
Flange, carburettor	1.6, 1.8, 1.8 Syncro		<b>F8-3044</b>	H=21
Flange, carburettor	1.6, 1.8		<b>F8-3045</b>	H=21
Flange, carburettor	1.6	01/1987 →	<b>F8-3047</b>	H=24
Flange, carburettor	1.6, 1.8		<b>F8-3047</b>	H=24
Flange, carburettor	1.8 i CAT		<b>F8-3048</b>	H=27; d=40
Bracket, engine mounting	1.8 Syncro		<b>F8-3049</b>	
Clamp, silencer	1.0, 1.3, 1.3 CAT, 1.6, 1.6 D, 1.6 TD, 1.8, 1.8 GTI, 1.8 GTI 16V, 1.8 GTI CAT, 1.8 GTI G60, 1.8 i CAT		<b>F8-4027</b>	H=17; W=53, 61
Mounting, stabilizer coupling rod	1.0, 1.3, 1.3 CAT, 1.6, 1.6 D, 1.6 TD, 1.8, 1.8 GTI, 1.8 GTI 16V, 1.8 GTI CAT, 1.8 i CAT, 1.8 Syncro	Coupling Rod	<b>F8-4060</b>	H=14; d=12; D=38
Rubber Buffer, suspension	1.0, 1.3, 1.3 CAT, 1.6, 1.6 D, 1.6 TD, 1.8, 1.8 GTI, 1.8 GTI 16V, 1.8 GTI CAT, 1.8 GTI G60, 1.8 i CAT, 1.8 i Syncro CAT, 1.8 Syncro		<b>F8-4063</b>	H=83; d1=18; d2=25; D1=48; D2=60

<b>F8-1006</b>	<b>F8-1007</b>	<b>F8-1007S</b>	<b>F8-1008</b>	<b>F8-1009B</b>	<b>F8-1009C</b>	<b>F8-1010</b>
Ref.Nr.: 191199402B	Ref.Nr.: 191407181A	Ref.Nr.: 191407181A	Ref.Nr.: 191407181E	Ref.Nr.: 176412329	Ref.Nr.: 357412329	Ref.Nr.: 191501541
<b>F8-1010S</b>	<b>F8-1025</b>	<b>F8-3036</b>	<b>F8-3040</b>	<b>F8-3042</b>	<b>F8-3044</b>	<b>F8-3045</b>
Ref.Nr.: 191501541	Ref.Nr.: 191199262C	Ref.Nr.: 377412335A	Ref.Nr.: 357199279	Ref.Nr.: 191411314	Ref.Nr.: 026129761A	Ref.Nr.: 027129761
<b>F8-3047</b>	<b>F8-3048</b>	<b>F8-3049</b>	<b>F8-4027</b>	<b>F8-4060</b>	<b>F8-4063</b>	
Ref.Nr.: 050129761C	Ref.Nr.: 050129761B	Ref.Nr.: 191199273C	Ref.Nr.: 171253147A	Ref.Nr.: 191411329	Ref.Nr.: 191412303A	



**Article Description****Article Nr.****Fitting Position**

<b>GOLF Mk II (19E, 1G1)</b>		<b>08/1983 → 12/1992</b>	
Rubber Buffer, suspension	1.8 GTI G60 Syncro		<b>F8-4063</b>
Protective Cap/Bellow, shock absorber	1.0, 1.3, 1.3 CAT, 1.6, 1.6 D, 1.6 TD, 1.8, 1.8 GTI, 1.8 GTI 16V, 1.8 GTI CAT, 1.8 i CAT, 1.8 Syncro		<b>F8-4064</b>
Bellow, steering	1.0, 1.3, 1.3 CAT, 1.6, 1.6 D, 1.6 TD, 1.8, 1.8 GTI, 1.8 GTI 16V, 1.8 GTI CAT, 1.8 GTI G60, 1.8 GTI G60 Syncro, 1.8 i CAT, 1.8 Syncro		<b>F8-4069</b>
Bellow, steering	1.0, 1.3, 1.3 CAT, 1.6, 1.6 D, 1.6 TD, 1.8, 1.8 GTI, 1.8 GTI 16V, 1.8 GTI CAT, 1.8 GTI G60, 1.8 GTI G60 Syncro, 1.8 i CAT, 1.8 Syncro		<b>F8-4075</b>
Bellow, steering	1.0, 1.3 CAT, 1.6, 1.6 D, 1.6 TD, 1.8, 1.8 GTI, 1.8 GTI 16V, 1.8 i CAT	ch.1G-L-000001→; 08/1989 →;	<b>F8-4076</b>
Bellow, steering	1.6 TD, 1.8 GTI G60		<b>F8-4076</b>
Bellow, steering	1.8 GTI CAT	ch.1G-L-000001→;	<b>F8-4076</b>
Bellow, driveshaft	1.3, 1.6	09/1983 →	<b>F8-4080</b>
Bellow, driveshaft	1.3, 1.6, 1.8, 1.8 i CAT		<b>F8-4080</b>
Mounting, steering gear	1.0, 1.3, 1.3 CAT, 1.6, 1.6 D, 1.6 TD, 1.8, 1.8 GTI, 1.8 GTI 16V, 1.8 GTI CAT, 1.8 GTI G60, 1.8 GTI G60 Syncro, 1.8 i CAT, 1.8 Syncro		<b>F8-5145</b>
Spring Cap	1.8 GTI G60, 1.8 GTI G60 Syncro		<b>F8-5360</b>
Spring Cap	1.0, 1.3, 1.3 CAT, 1.6, 1.6 D, 1.8, 1.8 GTI, 1.8 GTI 16V, 1.8 GTI CAT, 1.8 GTI G60, 1.8 GTI G60 Syncro, 1.8 i CAT, 1.8 i Syncro CAT, 1.8 Syncro		<b>F8-5362</b>
Spring Cap	1.3, 1.6, 1.6 D, 1.6 TD, 1.8 GTI	09/1983 →	<b>F8-5362</b>
Spring Mounting	1.0, 1.3, 1.3 CAT, 1.6, 1.6 D, 1.6 TD, 1.8, 1.8 GTI, 1.8 GTI 16V, 1.8 GTI CAT, 1.8 GTI G60, 1.8 GTI G60 Syncro, 1.8 i CAT, 1.8 i Syncro CAT, 1.8 Syncro		<b>F8-5393</b>
Stabiliser Mounting	1.0, 1.3, 1.6, 1.6 D, 1.6 TD, 1.8, 1.8 GTI, 1.8 GTI 16V, 1.8 GTI CAT, 1.8 GTI G60, 1.8 GTI G60 Syncro, 1.8 i CAT, 1.8 Syncro	Stabi. Diam. [mm]= 21.5	<b>F8-5395</b>
Stabiliser Mounting	1.3 CAT	NZ; Stabi. Diam. [mm]= 21.5	<b>F8-5395</b>
Stabiliser Mounting	1.8 GTI	PB; Stabi. Diam. [mm]= 21.5	<b>F8-5395</b>
Engine Mounting	1.0, 1.3, 1.3 CAT, 1.6, 1.6 D, 1.6 TD, 1.8, 1.8 GTI, 1.8 GTI 16V, 1.8 GTI CAT, 1.8 GTI G60, 1.8 GTI G60 Syncro, 1.8 i CAT, 1.8 i Syncro CAT, 1.8 Syncro		<b>F8-5401</b>
Top Strut Mounting	1.0, 1.3, 1.3 CAT, 1.6, 1.6 D, 1.6 TD, 1.8, 1.8 GTI, 1.8 GTI 16V, 1.8 GTI CAT, 1.8 GTI G60, 1.8 GTI G60 Syncro, 1.8 i CAT, 1.8 Syncro		<b>F8-5402</b>
Top Strut Mounting	1.0, 1.3, 1.3 CAT, 1.6, 1.6 D, 1.6 TD, 1.8, 1.8 GTI, 1.8 GTI 16V, 1.8 GTI CAT, 1.8 GTI G60, 1.8 GTI G60 Syncro, 1.8 i CAT, 1.8 Syncro		<b>F8-5403</b>
Engine Mounting	1.8 GTI G60, 1.8 GTI G60 Syncro		<b>F8-5491</b>

<b>F8-4063</b>	<b>F8-4064</b>	<b>F8-4069</b>	<b>F8-4075</b>	<b>F8-4076</b>	<b>F8-4080</b>	<b>F8-5145</b>
Ref.Nr.: 191412303A	Ref.Nr.: 191412135	Ref.Nr.: 171419831B	Ref.Nr.: 357422831	Ref.Nr.: 357422831B	Ref.Nr.: 113501149	Ref.Nr.: 191419883
<b>F8-5360</b>	<b>F8-5362</b>	<b>F8-5393</b>	<b>F8-5395</b>	<b>F8-5401</b>	<b>F8-5402</b>	<b>F8-5403</b>
Ref.Nr.: 191412341	Ref.Nr.: 191512113	Ref.Nr.: 1H0512149	Ref.Nr.: 1H0411314	Ref.Nr.: 191199292B	Ref.Nr.: 191512335	Ref.Nr.: 191512333
<b>F8-5491</b>	<b>F8-5554</b>					
Ref.Nr.: 357199381	Ref.Nr.: 191199233					

Article Description



Article Nr.

Fitting Position



<b>GOLF Mk II (19E, 1G1)</b>		<b>08/1983 → 12/1992</b>		
Engine Mounting	1.0, 1.3, 1.3 CAT, 1.6, 1.6 D, 1.6 TD, 1.8, 1.8 GTI, 1.8 GTI 16V, 1.8 GTI CAT, 1.8 GTI G60, 1.8 GTI G60 Syncro, 1.8 i CAT, 1.8 i Syncro CAT, 1.8 Syncro		<b>F8-5554</b>	H=39.5; d1=16; d2=24; D=50
Engine Mounting	1.3	01/1984 →	<b>F8-5554</b>	H=39.5; d1=16; d2=24; D=50
Rubber Buffer, suspension	1.0, 1.3, 1.6, 1.6 D, 1.6 TD, 1.8, 1.8 GTI, 1.8 GTI 16V, 1.8 GTI CAT, 1.8 GTI G60, 1.8 GTI G60 Syncro, 1.8 i CAT		<b>F8-5594</b>	H=146; d=10.5; D=55.6
Rubber Buffer, suspension	1.3 CAT	2G	<b>F8-5594</b>	H=146; d=10.5; D=55.6
Rubber Buffer, suspension	1.8 GTI	GZ	<b>F8-5594</b>	H=146; d=10.5; D=55.6
Rubber Buffer, suspension	1.8 Syncro	ch.→1G-L-085400;	<b>F8-5594</b>	H=146; d=10.5; D=55.6
Protective Cap/Bellow, shock absorber	1.0, 1.3, 1.6, 1.6 D, 1.6 TD, 1.8, 1.8 GTI, 1.8 GTI 16V, 1.8 GTI CAT, 1.8 GTI G60, 1.8 i CAT		<b>F8-5747</b>	H=90
Protective Cap/Bellow, shock absorber	1.3 CAT	2G, NZ	<b>F8-5747</b>	H=90
Protective Cap/Bellow, shock absorber	1.8 GTI	EV, GZ, PB	<b>F8-5747</b>	H=90
Protective Cap/Bellow, shock absorber	1.8 GTI G60 Syncro, 1.8 Syncro	ch.→1G-L-085400;	<b>F8-5747</b>	H=90; Overall Height [mm]=20
Repair Kit, suspension strut	1.0, 1.3, 1.3 CAT, 1.6, 1.6 D, 1.6 TD, 1.8, 1.8 GTI, 1.8 GTI 16V, 1.8 GTI CAT, 1.8 GTI G60, 1.8 GTI G60 Syncro, 1.8 i CAT, 1.8 i Syncro CAT, 1.8 Syncro	ch.19-E-300001→	<b>F8-6382</b>	
Sleeve, control arm mounting	1.0, 1.3, 1.3 CAT, 1.6, 1.6 D, 1.6 TD, 1.8, 1.8 GTI, 1.8 GTI 16V, 1.8 GTI CAT, 1.8 GTI G60, 1.8 GTI G60 Syncro, 1.8 i CAT, 1.8 i Syncro CAT, 1.8 Syncro, 2.0		<b>F8-6699</b>	d=16; L=50; D=17
Engine Mounting	1.0, 1.3	ch.19-E-300001→	<b>F8-6922</b>	H=65
Engine Mounting	1.0, 1.3 CAT	ch.→1G-N-300000	<b>F8-6922</b>	H=65
Engine Mounting	1.3		<b>F8-6922</b>	H=65
Engine Mounting	1.8 GTI 16V	ch.1G-MB015001, 1G-MW080001→; ch.→1G-N-300000	<b>F8-6922</b>	H=65
Bellow, driveshaft	1.0, 1.3, 1.6, 1.6 D, 1.6 TD, 1.8, 1.8 i CAT, 1.8 Syncro		<b>F8-7722</b>	d1=26; d2=78; L=110
Bellow, driveshaft	1.3 CAT	2G, NZ	<b>F8-7722</b>	d1=26; d2=78; L=110
Flange, carburettor	1.0	EngineHZ004801→	<b>F8-7744</b>	
Control Arm-/Trailing Arm Bush	1.0, 1.3, 1.3 CAT, 1.6, 1.6 D, 1.6 TD, 1.8, 1.8 GTI, 1.8 GTI 16V, 1.8 GTI CAT, 1.8 GTI G60, 1.8 GTI G60 Syncro, 1.8 i CAT, 1.8 i Syncro CAT, 1.8 Syncro, 2.0		<b>F8-7978</b>	
Control Arm-/Trailing Arm Bush	1.0, 1.3, 1.3 CAT, 1.6, 1.6 D, 1.6 TD, 1.8, 1.8 GTI, 1.8 GTI 16V, 1.8 GTI CAT, 1.8 GTI G60, 1.8 GTI G60 Syncro, 1.8 i CAT, 1.8 i Syncro CAT, 1.8 Syncro		<b>G9-648</b>	H=54; d=12; D1=33; D2=36
Bellow, steering	1.0, 1.3, 1.3 CAT, 1.6 D, 1.6 TD, 1.8, 1.8 GTI, 1.8 GTI G60, 1.8 GTI G60 Syncro, 1.8 i Syncro CAT, 1.8 Syncro	with clamps;	<b>LM-10003S</b>	d1=9; d2=43; L [mm]=210
Bellow, steering	1.3, 1.6, 1.6 D, 1.6 TD, 1.8 i CAT	ch.19-E-300001→; ch.→1G-K-990000; with clamps;	<b>LM-10003S</b>	d1=9; d2=43; L [mm]=210

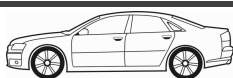

**Article Description****Article Nr.****Fitting Position**

<b>GOLF Mk II (19E, 1G1)</b>		<b>08/1983 → 12/1992</b>	
Bellow, steering	1.6, 1.8, 1.8 GTI, 1.8 GTI 16V, 1.8 GTI CAT, 1.8 Syncro	ch.→1G-K-990000; with clamps;	<b>LM-10003S</b>
Bellow, steering	1.0, 1.3, 1.3 CAT, 1.6, 1.6 D, 1.6 TD, 1.8, 1.8 GTI, 1.8 GTI 16V, 1.8 GTI CAT, 1.8 GTI G60, 1.8 GTI G60 Syncro, 1.8 i CAT, 1.8 i Syncro CAT, 1.8 Syncro	with clamps	<b>LM-10006S</b>
Bellow, steering	1.0, 1.3, 1.3 CAT, 1.6, 1.6 D, 1.6 TD, 1.8, 1.8 GTI, 1.8 GTI 16V, 1.8 GTI CAT, 1.8 GTI G60, 1.8 GTI G60 Syncro, 1.8 i CAT, 1.8 i Syncro CAT, 1.8 Syncro, 2.0	with clamps;	<b>LM-10024S</b>
Bellow, steering	1.0, 1.3, 1.3 CAT, 1.6, 1.6 D, 1.6 TD, 1.8, 1.8 GTI, 1.8 GTI 16V, 1.8 GTI CAT, 1.8 i CAT, 2.0	ch.1G-L-000001→; with clamps	<b>LM-10029S</b>
Bellow, steering	1.6 TD, 1.8 GTI G60	with clamps	<b>LM-10029S</b>
Bellow, steering	1.0, 1.3, 1.3 CAT, 1.6, 1.6 D, 1.6 TD, 1.8, 1.8 GTI, 1.8 GTI 16V, 1.8 GTI CAT, 1.8 GTI G60, 1.8 GTI G60 Syncro, 1.8 i CAT, 1.8 i Syncro CAT, 1.8 Syncro, 2.0	with clamps;	<b>LM-10050S</b>
Bellow, driveshaft	1.0, 1.3, 1.3 CAT, 1.6, 1.6 D, 1.6 TD, 1.8, 1.8 GTI G60 Syncro, 1.8 i CAT, 1.8 Syncro		<b>M-830220</b>
Bellow Set, drive shaft	1.0, 1.3, 1.6, 1.6 D, 1.6 TD, 1.8, 1.8 GTI G60 Syncro, 1.8 i CAT, 1.8 Syncro		<b>MK-830220</b>
Bellow Set, drive shaft	1.0, 1.3, 1.6, 1.6 D, 1.6 TD, 1.8, 1.8 GTI G60 Syncro, 1.8 i CAT, 1.8 Syncro		<b>MK-830220</b>
Bellow Set, drive shaft	1.3 CAT	2G, NZ	<b>MK-830220</b>
Bellow Set, drive shaft	1.3, 1.6 TD, 1.8 Syncro		<b>MK-830220S</b>
<b>GOLF Mk III (1H1)</b>		<b>08/1991 → 09/1997</b>	
Dust Cover Kit, shock absorber	1.4, 1.6, 1.8, 1.8 Syncro , 1.9 D, 1.9 SDI, 1.9 TD,GTD, 1.9 TDI, 2.0, 2.0 GTI 16V, 2.8 VR6		<b>AK-732516</b>
Dust Cover Kit, shock absorber	1.4, 1.6, 1.8, 1.8 Syncro , 1.9 D, 1.9 SDI, 1.9 TD,GTD, 1.9 TDI, 1.9 TDI Syncro , 2.0, 2.0 GTI 16V, 2.0 Syncro , 2.8 VR6, 2.9 VR6 Syncro		<b>AK-733023</b>
Dust Cover Kit, shock absorber	1.4, 1.6, 1.8, 1.9 D, 1.9 SDI, 1.9 TD,GTD, 1.9 TDI, 2.0		<b>AK-735032</b>
Dust Cover Kit, shock absorber	All Models	<b>ST</b>	<b>AK-735410</b> H=210
Alternator Freewheel Clutch	1.9 D, 1.9 TD,GTD, 1.9 TDI, 1.9 TDI Syncro		<b>F5-1007</b>
Control Arm-/Trailing Arm Bush	1.4, 1.6, 1.8, 1.8 Syncro , 1.9 D, 1.9 SDI, 1.9 TD,GTD, 1.9 TDI, 1.9 TDI Syncro , 2.0, 2.0 GTI 16V, 2.0 Syncro , 2.8 VR6, 2.9 VR6 Syncro , Citystromer	without guide sleeve	<b>F8-1007</b>
Control Arm-/Trailing Arm Bush	1.4, 1.6, 1.8, 1.8 Syncro , 1.9 D, 1.9 SDI, 1.9 TD,GTD, 1.9 TDI, 1.9 TDI Syncro , 2.0, 2.0 GTI 16V, 2.0 Syncro , 2.8 VR6, 2.9 VR6 Syncro , Citystromer	with guide sleeve	<b>F8-1007S</b>
Repair Kit, link	1.4, 1.6, 1.8, 1.8 Syncro , 1.9 D, 1.9 SDI, 1.9 TD,GTD, 1.9 TDI, 1.9 TDI Syncro , 2.0, 2.0 GTI 16V, 2.0 Syncro , 2.8 VR6, 2.9 VR6 Syncro , Citystromer	with guide sleeve	<b>F8-1008</b>
Top Strut Mounting	1.4	ch.→1H-SB019475, 1H-SW062538	<b>F8-1009B</b>
Top Strut Mounting	1.4, 1.6, 1.8, 1.9 D, 1.9 TD,GTD, 1.9 TDI, 2.0, 2.8 VR6		<b>F8-1009B</b>

<b>AK-732516</b>	<b>AK-733023</b>	<b>AK-735032</b>	<b>AK-735410</b>	<b>F5-1007</b>	<b>F8-1007</b>	<b>F8-1007S</b>
Ref.Nr.:	Ref.Nr.: 191412303	Ref.Nr.:	Ref.Nr.: 1J0412303	Ref.Nr.: 028903119AQ	Ref.Nr.: 191407181A	Ref.Nr.: 191407181A
<b>F8-1008</b>	<b>F8-1009B</b>	<b>LM-10003S</b>	<b>LM-10006S</b>	<b>LM-10024S</b>	<b>LM-10029S</b>	<b>LM-10050S</b>
Ref.Nr.: 191407181E	Ref.Nr.: 176412329	Ref.Nr.: 357422831A	Ref.Nr.: 1H0422831B	Ref.Nr.: 171419831B	Ref.Nr.: 1H0422831A	Ref.Nr.: 171419831C
<b>M-830220</b>	<b>MK-830220</b>	<b>MK-830220S</b>				
Ref.Nr.: 191498203C	Ref.Nr.: 171498203	Ref.Nr.:				

Article Description



Article Nr.

Fitting Position



GOLF Mk III (1H1)			08/1991 → 09/1997		
Top Strut Mounting	1.6	ch.→1H-SB019475, 1H-SW062538;  AEK	<b>F8-1009B</b>		d=14; D=132
Top Strut Mounting	1.4, 1.6, 1.8, 1.9 D, 1.9 TD,GTD, 1.9 TDI	ch.1H-N-000001→	<b>F8-1009C</b>		H1=39; H2=55; d=14; D=127
Top Strut Mounting	1.6, 1.9 TDI, 2.0 GTI 16V		<b>F8-1009C</b>		H1=39; H2=55; d=14; D=127
Top Strut Mounting	1.8 Syncro , 1.9 TDI Syncro , 2.0 Syncro , 2.9 VR6 Syncro	ch.→1H-S-062538	<b>F8-1009C</b>		H1=39; H2=55; d=14; D=127
Top Strut Mounting	2.0	ch.1H-N-000001→;	<b>F8-1009C</b>		H1=39; H2=55; d=14; D=127
Engine Mounting	1.6, 1.9 TD,GTD, 2.0		<b>F8-1011</b>		H=133; D1=80; D2=108
Engine Mounting	1.8, 1.8 Syncro		<b>F8-1011</b>		H=133; D1=80; D2=108
Engine Mounting	1.4	01/1995 →	<b>F8-1015</b>		H=82; D1=55; D2=71
Engine Mounting	1.4, 1.6, 1.8, 1.8 Syncro , 1.9 D, 1.9 SDI, 1.9 TD,GTD, 2.0, 2.0 GL, 2.0 Syncro		<b>F8-1015</b>		H=82; D1=55; D2=71
Top Strut Mounting	1.4, 1.6, 1.8, 1.9 D, 1.9 TD,GTD, 1.9 TDI, 2.0, 2.0 GTI 16V, 2.8 VR6	01/1995 →;	<b>F8-1034</b>		H=50; d=27; D=98
Top Strut Mounting	1.6, 1.9 TDI, 2.8 VR6, 2.9 VR6 Syncro		<b>F8-1034</b>		H=50; d=27; D=98
Top Strut Mounting	1.8 Syncro	ch.1H-S-062539→; 01/1995 →;	<b>F8-1034</b>		H=50; d=27; D=98
Top Strut Mounting	1.9 SDI	04/1997 →;	<b>F8-1034</b>		H=50; d=27; D=98
Top Strut Mounting	1.9 TDI Syncro , 2.0 Syncro	ch.1H-S-062539→;	<b>F8-1034</b>		H=50; d=27; D=98
Top Strut Mounting	1.4, 1.6, 1.8, 1.9 D, 1.9 TD,GTD, 1.9 TDI, 2.0, 2.0 GTI 16V, 2.8 VR6	01/1995 →;	<b>F8-1034S</b>		H=51; d=14; D=96
Top Strut Mounting	1.6, 1.9 TDI, 2.8 VR6, 2.9 VR6 Syncro		<b>F8-1034S</b>		H=51; d=14; D=96
Top Strut Mounting	1.8 Syncro , 1.9 TDI Syncro , 2.0 Syncro	ch.1H-S-062539→; ;	<b>F8-1034S</b>		H=51; d=14; D=96
Top Strut Mounting	1.9 SDI	04/1997 →;	<b>F8-1034S</b>		H=51; d=14; D=96
Anti-Friction Bearing	1.4, 1.6, 1.8, 1.9 D, 1.9 TD,GTD, 1.9 TDI, 2.0		<b>F8-3036</b>		
Anti-Friction Bearing	1.8 Syncro	ABS	<b>F8-3036</b>		
Anti-Friction Bearing	1.4, 1.6, 1.8, 1.9 D, 1.9 TD,GTD, 1.9 TDI, 2.0	08/1994 →	<b>F8-3039</b>		H=14; d1=14; D=45
Anti-Friction Bearing	1.6, 1.9 SDI, 1.9 TDI, 1.9 TDI Syncro , 2.0 GL, 2.0 GTI 16V, 2.0 Syncro , 2.8 VR6, 2.9 VR6 Syncro , Citystromer		<b>F8-3039</b>		H=14; d1=14; D=45
Anti-Friction Bearing	1.8 Syncro	ADZ	<b>F8-3039</b>		H=14; d1=14; D=45
Engine Mounting	1.9 TDI, 1.9 TDI Syncro , 2.0 GTI 16V, 2.8 VR6, 2.9 VR6 Syncro		<b>F8-3041</b>		H=85; D1=69; D2=71; T [mm]=106
Stabiliser Mounting	1.4, 1.6, 1.8, 1.8 Syncro , 1.9 D, 1.9 SDI, 1.9 TD,GTD, 1.9 TDI, 1.9 TDI Syncro , 2.0, 2.0 GL, 2.0 GTI 16V, 2.0 Syncro , 2.8 VR6, 2.9 VR6 Syncro		<b>F8-3042</b>		H=33; d=17; W=35
Flange, carburettor	1.8, 1.8 Syncro		<b>F8-3048</b>		H=27; d=40
Engine Mounting	1.8	01/1996 →;	<b>F8-3053</b>		H=135; D1=79; D2=93
Engine Mounting	1.9 D, 1.9 SDI, 1.9 TD,GTD		<b>F8-3053</b>		H=135; D1=79; D2=93



**Article Description****Article Nr.****Fitting Position**

<b>GOLF Mk III (1H1)</b>			<b>08/1991 → 09/1997</b>		
Mounting, axle beam	1.4, 1.6, 1.8, 1.9 D, 1.9 SDI, 1.9 TD,GTD, 1.9 TDI, 2.0, 2.0 GTI 16V, 2.8 VR6		<b>F8-4008</b>		H1=54; H2=90; d=12; D=56
Repair Set, axle beam	1.4, 1.6, 1.8, 1.9 D, 1.9 SDI, 1.9 TD,GTD, 1.9 TDI, 2.0, 2.0 GTI 16V, 2.8 VR6, Citystromer	with fastening material	<b>F8-4008S</b>		H1=54; H2=90; d=12; D=56
Engine Mounting	1.6, 2.0	01/1996 →;	<b>F8-4016</b>		
Engine Mounting	1.9 TD,GTD		<b>F8-4016</b>		
Engine Mounting	2.0 GTI 16V	01/1996 →	<b>F8-4016</b>		
Engine Mounting	2.0 Syncro		<b>F8-4016</b>		
Engine Mounting	1.4, 1.6		<b>F8-4017</b>		
Holder, exhaust system	1.4, 1.6, 1.8, 1.8 Syncro , 1.9 D, 1.9 SDI, 1.9 TD,GTD, 1.9 TDI, 1.9 TDI Syncro , 2.0, 2.0 GTI 16V, 2.0 Syncro , 2.8 VR6, 2.9 VR6 Syncro		<b>F8-4025</b>		H=65; $\uparrow$ [mm]=86; W=35
Clamp, silencer	1.8 Syncro , 1.9 TDI Syncro , 2.0 Syncro , 2.9 VR6 Syncro		<b>F8-4027</b>		H=17; W=53, 61
Rubber Buffer, suspension	1.4, 1.6, 1.8, 1.9 D, 1.9 TD,GTD, 1.9 TDI, 2.0, 2.0 GTI 16V		<b>F8-4063</b>		H=83; d1=18; d2=25; D1=48; D2=60
Bellow, steering	1.4, 1.6, 1.8, 1.9 D, 1.9 SDI, 1.9 TD,GTD, 1.9 TDI, 2.0, 2.0 GTI 16V, 2.8 VR6		<b>F8-4069</b>		
Bellow, steering	1.4, 1.6, 1.8, 1.9 D, 1.9 SDI, 1.9 TD,GTD, 1.9 TDI, 2.0, 2.0 GTI 16V, 2.8 VR6		<b>F8-4075</b>		H=200; d=10; D=48
Bellow, steering	1.4, 1.6, 1.8, 1.8 Syncro , 1.9 D, 1.9 SDI, 1.9 TD,GTD, 1.9 TDI, 1.9 TDI Syncro , 2.0, 2.0 GL, 2.0 GTI 16V, 2.0 Syncro , 2.8 VR6, Citystromer		<b>F8-4076</b>		H=151; D1=20; D2=55
Bellow, driveshaft	1.4, 1.6, 1.9 D, 1.9 SDI, 1.9 TD,GTD, 1.9 TDI, 1.9 TDI Syncro		<b>F8-4080</b>		H=95; D1=29; D2=96
Mounting, steering gear	1.4, 1.6, 1.8, 1.9 D, 1.9 SDI, 1.9 TD,GTD, 1.9 TDI, 2.0, 2.0 GTI 16V, 2.8 VR6		<b>F8-5145</b>		d1=50.7; d2=48.3
Engine Mounting	1.6	Brown;  AEK, AFT	<b>F8-5346</b>		
Engine Mounting	2.0	Brown;  2E, ADY, AGG	<b>F8-5346</b>		
Engine Mounting	2.0 GL, 2.0 Syncro	Brown	<b>F8-5346</b>		
Engine Mounting	2.0 GTI 16V	ch. → 1H-RB060000, 1H-RW240000; Brown	<b>F8-5346</b>		
Spring Cap	1.4, 1.6, 1.8, 1.8 Syncro , 1.9 D, 1.9 SDI, 1.9 TD,GTD, 1.9 TDI, 1.9 TDI Syncro , 2.0, 2.0 GL, 2.0 GTI 16V, 2.0 Syncro , 2.8 VR6, 2.9 VR6 Syncro , Citystromer		<b>F8-5362</b>		
Spring Mounting	1.4, 1.6, 1.8, 1.8 Syncro , 1.9 D, 1.9 SDI, 1.9 TD,GTD, 1.9 TDI, 1.9 TDI Syncro , 2.0, 2.0 GTI 16V, 2.8 VR6, Citystromer		<b>F8-5393</b>		
Mounting, steering gear	1.4, 1.6, 1.8, 1.8 Syncro , 1.9 D, 1.9 SDI, 1.9 TD,GTD, 1.9 TDI, 1.9 TDI Syncro , 2.0, 2.0 GL, 2.0 GTI 16V, 2.0 Syncro , 2.8 VR6, 2.9 VR6 Syncro		<b>F8-5394</b>		
Stabiliser Mounting	1.4	ABD; Stabi. Diam. [mm]= 21.5	<b>F8-5395</b>		d=19

<b>F8-4008</b>	<b>F8-4008S</b>	<b>F8-4016</b>	<b>F8-4017</b>	<b>F8-4025</b>	<b>F8-4027</b>	<b>F8-4063</b>
Ref.Nr.: 1H0501541A	Ref.Nr.: 1H0501541	Ref.Nr.: 1H0199262G	Ref.Nr.: 1H0199262E	Ref.Nr.: 1H0253144	Ref.Nr.: 171253147A	Ref.Nr.: 191412303A
<b>F8-4069</b>	<b>F8-4075</b>	<b>F8-4076</b>	<b>F8-4080</b>	<b>F8-5145</b>	<b>F8-5346</b>	<b>F8-5362</b>
Ref.Nr.: 171419831B	Ref.Nr.: 357422831	Ref.Nr.: 357422831B	Ref.Nr.: 113501149	Ref.Nr.: 191419883	Ref.Nr.: 1H0199609G	Ref.Nr.: 191512113
<b>F8-5393</b>	<b>F8-5394</b>	<b>F8-5395</b>				
Ref.Nr.: 1H0512149	Ref.Nr.: 1H0422884	Ref.Nr.: 1H0411314				

Article Description



Article Nr.

Fitting Position



<b>GOLF Mk III (1H1)</b>				<b>08/1991 → 09/1997</b>	
Stabiliser Mounting	1.4, 1.6, 1.8, 1.8 Syncro , 1.9 D, 1.9 SDI, 1.9 TD,GTD, 1.9 TDI, 1.9 TDI Syncro , 2.0, 2.0 GL, 2.0 GTI 16V, 2.0 Syncro , 2.8 VR6, 2.9 VR6 Syncro , Citystromer	Stabi. Diam. [mm]= 21.5	<b>F8-5395</b>		d=19
Engine Mounting	1.9 TDI		<b>F8-5396</b>		
Engine Mounting	1.9 TDI, 1.9 TDI Syncro	1Z, AHU	<b>F8-5396</b>		
Engine Mounting	2.0 GTI 16V	ch.1H-RB060001, 1H-RW240001→; 01/1994 →	<b>F8-5396</b>		
Engine Mounting	1.6, 1.8, 1.8 Syncro		<b>F8-5397</b>		
Engine Mounting	1.4		<b>F8-5398</b>		
Engine Mounting	1.4	ch.1H-N-000001→	<b>F8-5398</b>		
Engine Mounting	1.6	ch.1H-N-000001→;  ABU	<b>F8-5398</b>		
Engine Mounting	1.9 SDI, 1.9 TDI, 1.9 TDI Syncro		<b>F8-5399</b>		
Engine Mounting	2.8 VR6, 2.9 VR6 Syncro		<b>F8-5400</b>		
Top Strut Mounting	1.4, 1.6, 1.8, 1.8 Syncro , 1.9 D, 1.9 SDI, 1.9 TD,GTD, 1.9 TDI, 1.9 TDI Syncro , 2.0 GTI 16V, 2.0 Syncro , 2.8 VR6		<b>F8-5402</b>		
Top Strut Mounting	2.0		<b>F8-5402</b>		
Top Strut Mounting	1.4, 1.6, 1.8, 1.8 Syncro , 1.9 D, 1.9 SDI, 1.9 TD,GTD, 1.9 TDI, 1.9 TDI Syncro , 2.0, 2.0 GTI 16V, 2.0 Syncro , 2.8 VR6, 2.9 VR6 Syncro		<b>F8-5403</b>		
Engine Mounting	1.4, 1.6, 1.8, 1.9 D, 1.9 TD,GTD, 1.9 TDI, 2.0, 2.0 GTI 16V, 2.8 VR6	ch.→1H-PB010000, 1H-PW-080000	<b>F8-5554</b>		H=39.5; d1=16; d2=24; D=50
Spring Cap	1.4, 1.6, 1.8, 1.8 Syncro , 1.9 D, 1.9 TD,GTD, 2.0, 2.0 GTI 16V, 2.8 VR6	01/1994 →	<b>F8-5580</b>		D=92
Spring Cap	1.6, 1.9 SDI, 1.9 TDI, 1.9 TDI Syncro , 2.0 Syncro , 2.9 VR6 Syncro , Citystromer		<b>F8-5580</b>		D=92
Rubber Buffer, suspension	1.4	ABD	<b>F8-5594</b>		H=146; d=10.5; D=55.6
Rubber Buffer, suspension	1.4, 1.6, 1.8, 1.8 Syncro , 1.9 D, 1.9 SDI, 1.9 TD,GTD, 1.9 TDI, 2.0 GL		<b>F8-5594</b>		H=146; d=10.5; D=55.6
Rubber Buffer, suspension	1.6	AEK	<b>F8-5594</b>		H=146; d=10.5; D=55.6
Rubber Buffer, suspension	1.9 TDI	AHU	<b>F8-5594</b>		H=146; d=10.5; D=55.6
Rubber Buffer, suspension	2.0	01/1996 →;  ADY;	<b>F8-5594</b>		H=146; d=10.5; D=55.6
Belt Pulley, crankshaft	1.9 D, 1.9 TD,GTD, 1.9 TDI	ch.1H-N-000001→; Number of Ribs: 5; Parameter: 6PK	<b>F8-5649</b>		H=31.5; d=30.02; Mounting points diam.[mm]=8.5; D1=161.5; D2=160.5
Belt Pulley, crankshaft	1.9 SDI, 1.9 TDI, 1.9 TDI Syncro	Number of Ribs: 5; Parameter: 6PK	<b>F8-5649</b>		H=31.5; d=30.02; Mounting points diam.[mm]=8.5; D1=161.5; D2=160.5
Holder, engine mounting	1.4, 1.6, 1.8, 1.8 Syncro , 1.9 D, 1.9 SDI, 1.9 TD,GTD, 1.9 TDI, 1.9 TDI Syncro , 2.0, 2.0 GTI 16V, 2.0 Syncro , 2.8 VR6, 2.9 VR6 Syncro , Citystromer		<b>F8-5672</b>		H=39.5; D=24
Holder, engine mounting	2.0 GL, 2.8 VR6	ch.1H-PB010001, 1H-PW080001→	<b>F8-5672</b>		H=39.5; D=24

<b>F8-5395</b>	<b>F8-5396</b>	<b>F8-5397</b>	<b>F8-5398</b>	<b>F8-5399</b>	<b>F8-5400</b>	<b>F8-5402</b>
Ref.Nr.: 1H0411314	Ref.Nr.: 1H0199609J	Ref.Nr.: 1H0199609F	Ref.Nr.: 1H0199609E	Ref.Nr.: 1H0199262L	Ref.Nr.: 1H0199262D	Ref.Nr.: 191512335
<b>F8-5403</b>	<b>F8-5554</b>	<b>F8-5580</b>	<b>F8-5594</b>	<b>F8-5649</b>	<b>F8-5672</b>	<b>F8-5683</b>
Ref.Nr.: 191512333	Ref.Nr.: 191199233	Ref.Nr.: 1J0412341	Ref.Nr.: 191512131B	Ref.Nr.: 028105243T	Ref.Nr.: 1H0199233A	Ref.Nr.: 357413175A

**Article Description****Article Nr.****Fitting Position****GOLF Mk III (1H1)****08/1991 → 09/1997**

Protective Cap/Bellow, shock absorber	All Models		<b>F8-5683</b>		H=210
Protective Cap/Bellow, shock absorber	1.4	ABD	<b>F8-5747</b>		H=90
Protective Cap/Bellow, shock absorber	1.4, 1.6, 1.8, 1.8 Syncro , 1.9 D, 1.9 SDI, 1.9 TD,GTD, 1.9 TDI, 1.9 TDI Syncro , 2.0, 2.0 GL, 2.0 GTI 16V, 2.0 Syncro , 2.8 VR6, 2.9 VR6 Syncro		<b>F8-5747</b>		H=90
Rubber Buffer, suspension	1.4, 1.6, 1.8, 1.8 Syncro , 1.9 D, 1.9 TD,GTD, 1.9 TDI, 2.0, 2.0 GTI 16V	09/1994 →	<b>F8-5993</b>		H=83
Rubber Buffer, suspension	1.6, 1.9 TDI Syncro , 2.0 Syncro , 2.8 VR6, 2.9 VR6 Syncro , Citystromer		<b>F8-5993</b>		H=83
Repair Kit, suspension strut	1.4, 1.6, 1.8, 1.8 Syncro , 1.9 D, 1.9 SDI, 1.9 TD,GTD, 1.9 TDI, 1.9 TDI Syncro , 2.0, 2.0 GTI 16V, 2.0 Syncro , 2.8 VR6, 2.9 VR6 Syncro		<b>F8-6382</b>		
Sleeve, control arm mounting	All Models		<b>F8-6699</b>		d=16; L=50; D=17
Engine Mounting	2.8 VR6, 2.9 VR6 Syncro		<b>F8-6717</b>		
Engine Mounting	1.4	ch.1H-N-000001→;  ABD	<b>F8-6922</b>		H=65
Engine Mounting	1.6		<b>F8-6922</b>		H=65
Bellow, driveshaft	1.4	ABD	<b>F8-7722</b>		d1=26; d2=78; L=110
Bellow, driveshaft	1.4, 1.6, 1.9 D, 1.9 SDI		<b>F8-7722</b>		d1=26; d2=78; L=110
Bellow, driveshaft	1.6	AEK;	<b>F8-7722</b>		d1=26; d2=78; L=110
Bellow, driveshaft	1.6	AFT;	<b>F8-7722</b>		d1=26; d2=78; L=110
Control Arm-/Trailing Arm Bush	1.3, 1.4, 1.6, 1.8, 1.8 Syncro , 1.9 D, 1.9 SDI, 1.9 TD,GTD, 1.9 TDI, 1.9 TDI Syncro , 2.0, 2.0 GTI 16V, 2.0 Syncro , 2.8 VR6, 2.9 VR6 Syncro , Citystromer		<b>F8-7978</b>		
Control Arm-/Trailing Arm Bush	1.4, 1.6, 1.8, 1.8 Syncro , 1.9 D, 1.9 SDI, 1.9 TD,GTD, 1.9 TDI, 1.9 TDI Syncro , 2.0 Syncro , 2.9 VR6 Syncro , Citystromer		<b>G9-648</b>		H=54; d=12; D1=33; D2=36
Control Arm-/Trailing Arm Bush	1.9 TDI, 2.0 GTI 16V, 2.8 VR6	ch.1H-N-000001, 1H-W-500000→	<b>G9-648</b>		H=54; d=12; D1=33; D2=36
Control Arm-/Trailing Arm Bush	2.0	ch.1H-N-000001→; ch.→1H-W-500000;	<b>G9-648</b>		H=54; d=12; D1=33; D2=36
Bellow, steering	All Models	for steering gear manufacturer: TRW; with clamps;	<b>LM-10003S</b>		d1=9; d2=43; L [mm]=210
Bellow, steering	All Models	with clamps	<b>LM-10006S</b>		d1=10; d2=41; L [mm]=210
Bellow, steering	1.3, 1.4, 1.6, 1.8, 1.8 Syncro , 1.9 D, 1.9 TD,GTD, 1.9 TDI, 2.0, 2.0 GL, 2.0 GTI 16V, 2.8 VR6, Citystromer	ch.→1H-TW500000; with clamps;	<b>LM-10024S</b>		d1=25; d2=41; L [mm]=120
Bellow, steering	All Models	for steering gear manufacturer: ZF; with clamps;	<b>LM-10029S</b>		d1=13; d2=45; L [mm]=138
Bellow, steering	1.3, 1.4, 1.6, 1.8, 1.8 Syncro , 1.9 D, 1.9 TD,GTD, 1.9 TDI, 2.0, 2.0 GL, 2.0 GTI 16V, 2.8 VR6, Citystromer	ch.→1H-TW500000; with clamps;	<b>LM-10050S</b>		d1=25; d2=39; L [mm]=126
Bellow, driveshaft	1.4, 1.6, 1.8 Syncro , 1.9 D, 1.9 SDI, 1.9 TDI Syncro , 2.0 Syncro , 2.9 VR6 Syncro		<b>M-830220</b>		

<b>F8-5683</b>	<b>F8-5747</b>	<b>F8-5993</b>	<b>F8-6382</b>	<b>F8-6699</b>	<b>F8-6717</b>	<b>F8-6922</b>
Ref.Nr.: 357413175A	Ref.Nr.: 191513425	Ref.Nr.: 357412303F	Ref.Nr.: 191512333S	Ref.Nr.: 191407190A	Ref.Nr.: 1H0199609D	Ref.Nr.: 191199381A
<b>F8-7722</b>	<b>F8-7978</b>	<b>G9-648</b>	<b>LM-10003S</b>	<b>LM-10006S</b>	<b>LM-10024S</b>	<b>LM-10029S</b>
Ref.Nr.: 191407285F	Ref.Nr.: 357407182F	Ref.Nr.: 357407182	Ref.Nr.: 357422831A	Ref.Nr.: 1H0422831B	Ref.Nr.: 171419831B	Ref.Nr.: 1H0422831A
<b>LM-10050S</b>	<b>M-830220</b>	<b>MK-830220</b>				
Ref.Nr.: 171419831C	Ref.Nr.: 191498203C	Ref.Nr.: 171498203				

Article Description



Article Nr.

Fitting Position



<b>GOLF Mk III (1H1)</b>			<b>08/1991 → 09/1997</b>		
Bellow Set, drive shaft	1.4	ABD	<b>MK-830220</b>		
Bellow Set, drive shaft	1.4, 1.6, 1.8 Syncro , 1.9 D, 1.9 SDI, 1.9 TDI Syncro , 2.0 Syncro , 2.9 VR6 Syncro		<b>MK-830220</b>		
Bellow Set, drive shaft	1.4, 1.6, 1.8 Syncro , 1.9 D, 1.9 SDI, 1.9 TDI Syncro , 2.0 Syncro , 2.9 VR6 Syncro		<b>MK-830220</b>		
Bellow Set, drive shaft	1.6	AEK, AFT;	<b>MK-830220</b>		
Bellow Set, drive shaft	1.9 D, 1.9 SDI		<b>MK-830220S</b>		
<b>GOLF Mk III Convertible (1E7)</b>			<b>07/1993 → 05/1998</b>		
Dust Cover Kit, shock absorber	All Models		<b>AK-732516</b>		
Dust Cover Kit, shock absorber	All Models		<b>AK-733023</b>		
Dust Cover Kit, shock absorber	All Models	<b>ST</b>	<b>AK-735410</b>		H=210
Alternator Freewheel Clutch	1.9 TDI		<b>F5-1007</b>		
Control Arm-/Trailing Arm Bush	All Models	without guide sleeve	<b>F8-1007</b>		H1=26; H2=41; d=17; D1=60; D2=68
Control Arm-/Trailing Arm Bush	All Models	with guide sleeve	<b>F8-1007S</b>		H1=26; H2=41; d=17; D1=60; D2=68
Repair Kit, link	All Models	with guide sleeve	<b>F8-1008</b>		H1=24; H2=41; d=17; D=60
Engine Mounting	1.6, 2.0		<b>F8-1011</b>		H=133; D1=80; D2=108
Engine Mounting	1.8		<b>F8-1011</b>		H=133; D1=80; D2=108
Top Strut Mounting	All Models		<b>F8-1034</b>		H=50; d=27; D=98
Top Strut Mounting	All Models		<b>F8-1034S</b>		H=51; d=14; D=96
Anti-Friction Bearing	All Models		<b>F8-3039</b>		H=14; d1=14; D=45
Flange, carburettor	1.8		<b>F8-3048</b>		H=27; d=40
Engine Mounting	1.8		<b>F8-3053</b>		H=135; D1=79; D2=93
Repair Set, axle beam	All Models	with fastening material	<b>F8-4008S</b>		H1=54; H2=90; d=12; D=56
Engine Mounting	1.6, 2.0	01/1995 →;	<b>F8-4016</b>		
Holder, exhaust system	All Models		<b>F8-4025</b>		H=65; $\tau$ [mm]=86; W=35
Bellow, steering	All Models		<b>F8-4075</b>		H=200; d=10; D=48
Bellow, steering	1.6, 1.9 TDI		<b>F8-4076</b>		H=151; D1=20; D2=55
Bellow, steering	1.8, 2.0	ch. → 1E-R-030000;	<b>F8-4076</b>		H=151; D1=20; D2=55
Engine Mounting	1.6	Brown;  AEK, AFT	<b>F8-5346</b>		
Engine Mounting	2.0	Brown;  ADY, AGG	<b>F8-5346</b>		
Spring Cap	All Models		<b>F8-5362</b>		
Spring Mounting	All Models		<b>F8-5393</b>		
Mounting, steering gear	All Models		<b>F8-5394</b>		
Engine Mounting	1.9 TDI		<b>F8-5396</b>		

<b>AK-732516</b>	<b>AK-733023</b>	<b>AK-735410</b>	<b>F5-1007</b>	<b>F8-1007</b>	<b>F8-1007S</b>	<b>F8-1008</b>
Ref.Nr.:	Ref.Nr.: 191412303	Ref.Nr.: 1J0412303	Ref.Nr.: 028903119AQ	Ref.Nr.: 191407181A	Ref.Nr.: 191407181A	Ref.Nr.: 191407181E
<b>F8-1011</b>	<b>F8-1034</b>	<b>F8-1034S</b>	<b>F8-3039</b>	<b>F8-3048</b>	<b>F8-3053</b>	<b>F8-4008S</b>
Ref.Nr.: 1H0199262F	Ref.Nr.: 357412331A	Ref.Nr.: 7201848S1	Ref.Nr.: 357412249A	Ref.Nr.: 050129761B	Ref.Nr.: 1H0199609B	Ref.Nr.: 1H0501541
<b>F8-4016</b>	<b>F8-4025</b>	<b>F8-4075</b>	<b>F8-4076</b>	<b>F8-5346</b>	<b>F8-5362</b>	<b>F8-5393</b>
Ref.Nr.: 1H0199262G	Ref.Nr.: 1H0253144	Ref.Nr.: 357422831	Ref.Nr.: 357422831B	Ref.Nr.: 1H0199609G	Ref.Nr.: 191512113	Ref.Nr.: 1H0512149

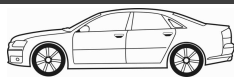

**Article Description****Article Nr.****Fitting Position**

<b>GOLF Mk III Convertible (1E7)</b>				<b>07/1993 → 05/1998</b>	
Engine Mounting	1.8		<b>F8-5397</b>		
Engine Mounting	1.9 TDI		<b>F8-5399</b>		
Top Strut Mounting	All Models		<b>F8-5402</b>		
Top Strut Mounting	1.6, 1.9 TDI		<b>F8-5403</b>		
Top Strut Mounting	1.8, 2.0	01/1994 →	<b>F8-5403</b>		
Engine Mounting	1.9 TDI		<b>F8-5491</b>		
Rubber Buffer, suspension	1.6, 1.8, 1.9 TDI		<b>F8-5594</b>		H=146; d=10.5; D=55.6
Rubber Buffer, suspension	1.9 TDI	1Z	<b>F8-5594</b>		H=146; d=10.5; D=55.6
Rubber Buffer, suspension	2.0	AKR	<b>F8-5594</b>		H=146; d=10.5; D=55.6
Belt Pulley, crankshaft	1.9 TDI	Number of Ribs: 5; Parameter: 6PK	<b>F8-5649</b>		H=31.5; d=30.02; Mounting points diam. [mm]=8.5; D1=161.5; D2=160.5
Holder, engine mounting	All Models		<b>F8-5672</b>		H=39.5; D=24
Protective Cap/Bellow, shock absorber	All Models		<b>F8-5683</b>		H=210
Protective Cap/Bellow, shock absorber	1.6, 1.8, 1.9 TDI		<b>F8-5747</b>		H=90
Protective Cap/Bellow, shock absorber	2.0	ADY, AGG, AKR	<b>F8-5747</b>		H=90
Rubber Buffer, suspension	All Models		<b>F8-5993</b>		H=83
Repair Kit, suspension strut	All Models		<b>F8-6382</b>		
Sleeve, control arm mounting	All Models		<b>F8-6699</b>		d=16; L=50; D=17
Engine Mounting	1.6, 1.8, 2.0	ch.→1E-2-015000	<b>F8-6922</b>		H=65
Engine Mounting	1.8		<b>F8-6922</b>		H=65
Bellow, driveshaft	1.6	AEK, AFT	<b>F8-7722</b>		d1=26; d2=78; L=110
Bellow, driveshaft	1.9 TDI	AHU	<b>F8-7722</b>		d1=26; d2=78; L=110
Control Arm-/Trailing Arm Bush	All Models		<b>F8-7978</b>		
Control Arm-/Trailing Arm Bush	All Models		<b>G9-648</b>		H=54; d=12; D1=33; D2=36
Bellow, steering	1.6, 1.8, 2.0	for steering gear manufacturer: TRW; with clamps;	<b>LM-10003S</b>		d1=9; d2=43; L [mm]=210
Bellow, steering	1.9 TDI	with clamps;	<b>LM-10003S</b>		d1=9; d2=43; L [mm]=210
Bellow, steering	All Models	with clamps	<b>LM-10006S</b>		d1=10; d2=41; L [mm]=210
Bellow, steering	1.6, 1.8, 2.0	Manufacturer Restriction: ZF; with clamps;	<b>LM-10029S</b>		d1=13; d2=45; L [mm]=138
Bellow, driveshaft	1.6, 1.9 TDI		<b>M-830220</b>		
Bellow Set, drive shaft	1.6	AEK, AFT	<b>MK-830220</b>		
Bellow Set, drive shaft	1.9 TDI	AHU	<b>MK-830220</b>		



Article Description



Article Nr.

Fitting Position



**GOLF Mk III Estate (1H5)**

07/1993 → 04/1999

Dust Cover Kit, shock absorber	1.4, 1.6, 1.8, 1.8 Syncro, 1.9 D, 1.9 SDI, 1.9 TD, 1.9 TDI, 1.9 TDI Syncro, 2.0, 2.0 Syncro, 2.9 VR6 Syncro		AK-733023		
Rubber Buffer, suspension	1.4, 1.6, 1.8, 1.8 Syncro, 1.9 D, 1.9 SDI, 1.9 TD, 1.9 TDI, 1.9 TDI Syncro, 2.0, 2.0 Syncro, 2.9 VR6 Syncro		AK-735026		
Dust Cover Kit, shock absorber	1.4, 1.6, 1.8, 1.9 D, 1.9 TD, 1.9 TDI, 2.0		AK-735032		
Dust Cover Kit, shock absorber	All Models	Universal	AK-735145		
Dust Cover Kit, shock absorber	All Models	ST	AK-735410		H=210
Alternator Freewheel Clutch	1.9 D, 1.9 TD, 1.9 TDI, 1.9 TDI Syncro		F5-1007		
Control Arm-/Trailing Arm Bush	1.4, 1.6, 1.8, 1.8 Syncro, 1.9 D, 1.9 SDI, 1.9 TD, 1.9 TDI, 1.9 TDI Syncro, 2.0, 2.0 Syncro, 2.9 VR6 Syncro	without guide sleeve	F8-1007		H1=26; H2=41; d=17; D1=60; D2=68
Control Arm-/Trailing Arm Bush	1.4, 1.6, 1.8, 1.8 Syncro, 1.9 D, 1.9 SDI, 1.9 TD, 1.9 TDI, 1.9 TDI Syncro, 2.0, 2.0 Syncro, 2.9 VR6 Syncro	with guide sleeve	F8-1007S		H1=26; H2=41; d=17; D1=60; D2=68
Repair Kit, link	1.4, 1.6, 1.8, 1.8 Syncro, 1.9 D, 1.9 SDI, 1.9 TD, 1.9 TDI, 1.9 TDI Syncro, 2.0, 2.0 Syncro, 2.9 VR6 Syncro	with guide sleeve	F8-1008		H1=24; H2=41; d=17; D=60
Top Strut Mounting	1.4, 1.8, 1.8 Syncro		F8-1009B		d=14; D=132
Top Strut Mounting	1.4, 1.6, 1.8, 1.8 Syncro, 1.9 D, 1.9 TD, 1.9 TDI, 1.9 TDI Syncro, 2.0 Syncro, 2.9 VR6 Syncro	ch.→1H-S-062538	F8-1009C		H1=39; H2=55; d=14; D=127
Top Strut Mounting	1.4, 1.9 TDI		F8-1009C		H1=39; H2=55; d=14; D=127
Top Strut Mounting	2.0	ch.→1H-SB019475, 1H-SW062538;  ADY	F8-1009C		H1=39; H2=55; d=14; D=127
Engine Mounting	1.6, 1.9 TD, 2.0		F8-1011		H=133; D1=80; D2=108
Engine Mounting	1.8		F8-1011		H=133; D1=80; D2=108
Engine Mounting	1.4	01/1995 →	F8-1015		H=82; D1=55; D2=71
Engine Mounting	1.4, 1.6, 1.8, 1.9 D, 1.9 SDI, 1.9 TD, 2.0		F8-1015		H=82; D1=55; D2=71
Top Strut Mounting	1.4, 1.6, 1.8, 1.9 D, 1.9 TD, 1.9 TDI, 2.0	01/1995 →;	F8-1034		H=50; d=27; D=98
Top Strut Mounting	1.8 Syncro	ch.1H-S-062539→; 01/1995 →;	F8-1034		H=50; d=27; D=98
Top Strut Mounting	1.9 SDI	04/1997 →;	F8-1034		H=50; d=27; D=98
Top Strut Mounting	1.9 TDI Syncro, 2.0 Syncro	ch.1H-S-062539→;	F8-1034		H=50; d=27; D=98
Top Strut Mounting	1.9 TDI, 2.9 VR6 Syncro		F8-1034		H=50; d=27; D=98
Top Strut Mounting	1.4, 1.6, 1.8, 1.9 D, 1.9 TD, 1.9 TDI, 2.0	01/1995 →;	F8-1034S		H=51; d=14; D=96
Top Strut Mounting	1.8 Syncro, 1.9 TDI Syncro, 2.0 Syncro	ch.1H-S-062539→; ;	F8-1034S		H=51; d=14; D=96
Top Strut Mounting	1.9 SDI	04/1997 →;	F8-1034S		H=51; d=14; D=96
Top Strut Mounting	1.9 TDI, 2.9 VR6 Syncro		F8-1034S		H=51; d=14; D=96
Anti-Friction Bearing	1.4, 1.8, 1.9 D, 1.9 TD		F8-3036		
Anti-Friction Bearing	1.4, 1.8, 1.9 D, 1.9 TD	08/1994 →	F8-3039		H=14; d1=14; D=45
Anti-Friction Bearing	1.6, 1.8 Syncro, 1.9 SDI, 1.9 TDI, 1.9 TDI Syncro, 2.0, 2.0 Syncro, 2.9 VR6 Syncro		F8-3039		H=14; d1=14; D=45
Engine Mounting	1.9 TDI, 1.9 TDI Syncro, 2.9 VR6 Syncro		F8-3041		H=85; D1=69; D2=71; T [mm]=106

<b>AK-733023</b>	<b>AK-735026</b>	<b>AK-735032</b>	<b>AK-735145</b>	<b>AK-735410</b>	<b>F5-1007</b>	<b>F8-1007</b>
Ref.Nr.: 191412303	Ref.Nr.: 1H9512131	Ref.Nr.:	Ref.Nr.:	Ref.Nr.: 1J0412303	Ref.Nr.: 028903119AQ	Ref.Nr.: 191407181A
<b>F8-1007S</b>	<b>F8-1008</b>	<b>F8-1009B</b>	<b>F8-1009C</b>	<b>F8-1011</b>	<b>F8-1015</b>	<b>F8-1034</b>
Ref.Nr.: 191407181A	Ref.Nr.: 191407181E	Ref.Nr.: 176412329	Ref.Nr.: 357412329	Ref.Nr.: 1H0199262F	Ref.Nr.: 357199402	Ref.Nr.: 357412331A
<b>F8-1034S</b>	<b>F8-3036</b>	<b>F8-3039</b>	<b>F8-3041</b>	<b>F8-3042</b>		
Ref.Nr.: 7201848S1	Ref.Nr.: 377412335A	Ref.Nr.: 357412249A	Ref.Nr.: 357199402A	Ref.Nr.: 191411314		

**Article Description****Article Nr.****Fitting Position**

<b>GOLF Mk III Estate (1H5)</b>			<b>07/1993 → 04/1999</b>		
Stabiliser Mounting	All Models		<b>F8-3042</b>		H=33; d=17; W=35
Flange, carburettor	1.8		<b>F8-3048</b>		H=27; d=40
Engine Mounting	1.8	01/1996 →;	<b>F8-3053</b>		H=135; D1=79; D2=93
Engine Mounting	1.9 D, 1.9 SDI, 1.9 TD		<b>F8-3053</b>		H=135; D1=79; D2=93
Engine Mounting	1.6, 2.0	01/1996 →;	<b>F8-4016</b>		
Engine Mounting	1.9 TD		<b>F8-4016</b>		
Engine Mounting	1.4		<b>F8-4017</b>		
Holder, exhaust system	1.4, 1.6, 1.8, 1.8 Syncro, 1.9 D, 1.9 SDI, 1.9 TD, 1.9 TDI, 1.9 TDI Syncro, 2.0, 2.0 Syncro, 2.9 VR6 Syncro		<b>F8-4025</b>		H=65; $\tau$ [mm]=86; W=35
Clamp, silencer	1.8 Syncro, 1.9 TDI Syncro, 2.0 Syncro, 2.9 VR6 Syncro		<b>F8-4027</b>		H=17; W=53, 61
Rubber Buffer, suspension	1.4, 1.8, 1.9 D, 1.9 TD, 1.9 TDI, 2.0		<b>F8-4063</b>		H=83; d1=18; d2=25; D1=48; D2=60
Rubber Buffer, suspension	1.6	ch. → 1H-SB019475, 1H-SW062538;  AEK, AFT	<b>F8-4063</b>		H=83; d1=18; d2=25; D1=48; D2=60
Bellow, steering	1.4, 1.6, 1.8, 1.9 D, 1.9 SDI, 1.9 TD, 1.9 TDI, 2.0		<b>F8-4069</b>		
Bellow, steering	1.4, 1.6, 1.8, 1.8 Syncro, 1.9 D, 1.9 SDI, 1.9 TD, 1.9 TDI, 1.9 TDI Syncro, 2.0, 2.0 Syncro, 2.9 VR6 Syncro		<b>F8-4075</b>		H=200; d=10; D=48
Bellow, steering	All Models		<b>F8-4076</b>		H=151; D1=20; D2=55
Bellow, driveshaft	1.4, 1.6, 1.8, 1.8 Syncro, 1.9 D, 1.9 SDI, 1.9 TD, 1.9 TDI, 1.9 TDI Syncro		<b>F8-4080</b>		H=95; D1=29; D2=96
Engine Mounting	1.6	Brown;  AEK, AFT	<b>F8-5346</b>		
Engine Mounting	2.0	Brown;  2E, ADY, AGG	<b>F8-5346</b>		
Engine Mounting	2.0 Syncro	ch. 1H-N-000001 →; Brown	<b>F8-5346</b>		
Spring Cap	All Models		<b>F8-5362</b>		
Mounting, axle beam	1.4, 1.6, 1.8, 1.8 Syncro, 1.9 D, 1.9 SDI, 1.9 TD, 1.9 TDI, 1.9 TDI Syncro, 2.0, 2.0 Syncro, 2.9 VR6 Syncro		<b>F8-5392</b>		H=50; d=12
Repair Set, axle beam	1.4, 1.6, 1.8, 1.9 D, 1.9 SDI, 1.9 TD, 1.9 TDI, 2.0	with fastening material	<b>F8-5392S</b>		
Mounting, steering gear	All Models		<b>F8-5394</b>		
Stabiliser Mounting	1.4, 1.6, 1.8, 1.8 Syncro, 1.9 D, 1.9 SDI, 1.9 TD, 1.9 TDI, 2.0, 2.0 Syncro, 2.9 VR6 Syncro	Stabi. Diam. [mm]= 21.5	<b>F8-5395</b>		d=19
Stabiliser Mounting	1.9 TDI	AHU; Stabi. Diam. [mm]= 21.5	<b>F8-5395</b>		d=19
Stabiliser Mounting	1.9 TDI Syncro	1Z; Stabi. Diam. [mm]= 21.5	<b>F8-5395</b>		d=19
Engine Mounting	1.9 TDI		<b>F8-5396</b>		
Engine Mounting	1.9 TDI	1Z, AHU	<b>F8-5396</b>		
Engine Mounting	1.8, 1.8 Syncro		<b>F8-5397</b>		
Engine Mounting	1.4		<b>F8-5398</b>		
Engine Mounting	1.9 SDI, 1.9 TDI, 1.9 TDI Syncro		<b>F8-5399</b>		

<b>F8-3042</b>	<b>F8-3048</b>	<b>F8-3053</b>	<b>F8-4016</b>	<b>F8-4017</b>	<b>F8-4025</b>	<b>F8-4027</b>
Ref.Nr.: 191411314	Ref.Nr.: 050129761B	Ref.Nr.: 1H0199609B	Ref.Nr.: 1H0199262G	Ref.Nr.: 1H0199262E	Ref.Nr.: 1H0253144	Ref.Nr.: 171253147A
<b>F8-4063</b>	<b>F8-4069</b>	<b>F8-4075</b>	<b>F8-4076</b>	<b>F8-4080</b>	<b>F8-5346</b>	<b>F8-5362</b>
Ref.Nr.: 191412303A	Ref.Nr.: 171419831B	Ref.Nr.: 357422831	Ref.Nr.: 357422831B	Ref.Nr.: 113501149	Ref.Nr.: 1H0199609G	Ref.Nr.: 191512113
<b>F8-5392</b>	<b>F8-5392S</b>	<b>F8-5394</b>	<b>F8-5395</b>	<b>F8-5396</b>	<b>F8-5397</b>	<b>F8-5398</b>
Ref.Nr.: 1H9501541	Ref.Nr.: 1H9501541	Ref.Nr.: 1H0422884	Ref.Nr.: 1H0411314	Ref.Nr.: 1H0199609J	Ref.Nr.: 1H0199609F	Ref.Nr.: 1H0199609E

Article Description



Article Nr.

Fitting Position



**GOLF Mk III Estate (1H5)**

07/1993 → 04/1999

Engine Mounting	2.9 VR6 Syncro		F8-5400		
Top Strut Mounting	1.4, 1.6, 1.8, 1.9 D, 1.9 SDI, 1.9 TD, 1.9 TDI, 2.0		F8-5402		
Top Strut Mounting	1.4, 1.6, 1.8, 1.9 D, 1.9 SDI, 1.9 TD, 1.9 TDI, 2.0		F8-5403		
Engine Mounting	1.4, 1.8, 1.9 D, 1.9 TD, 2.0	ch.→1H-PW-080000	F8-5554		H=39.5; d1=16; d2=24; D=50
Spring Cap	1.4, 1.8, 1.9 D, 1.9 TD, 2.0	01/1994 →	F8-5580		D=92
Spring Cap	1.6, 1.8 Syncro, 1.9 SDI, 1.9 TDI, 1.9 TDI Syncro, 2.0 Syncro, 2.9 VR6 Syncro		F8-5580		D=92
Belt Pulley, crankshaft	1.9 D, 1.9 SDI, 1.9 TD, 1.9 TDI, 1.9 TDI Syncro	Number of Ribs: 5; Parameter: 6PK	F8-5649		H=31.5; d=30.02; Mounting points diam.[mm]=8.5; D1=161.5; D2=160.5
Holder, engine mounting	1.4, 1.6, 1.8, 1.9 D, 1.9 SDI, 1.9 TD, 1.9 TDI, 2.0		F8-5672		H=39.5; D=24
Holder, engine mounting	2.0	ch.1H-PB010001, 1H-PW080001→	F8-5672		H=39.5; D=24
Protective Cap/Bellow, shock absorber	All Models		F8-5683		H=210
Rubber Buffer, suspension	1.4, 1.6, 1.8, 1.9 D, 1.9 TD, 1.9 TDI, 2.0	09/1994 →	F8-5993		H=83
Rubber Buffer, suspension	1.8 Syncro, 1.9 TDI, 1.9 TDI Syncro, 2.0 Syncro, 2.9 VR6 Syncro		F8-5993		H=83
Repair Kit, suspension strut	1.4, 1.6, 1.8, 1.8 Syncro, 1.9 D, 1.9 SDI, 1.9 TD, 1.9 TDI, 1.9 TDI Syncro, 2.0, 2.0 Syncro, 2.9 VR6 Syncro		F8-6382		
Sleeve, control arm mounting	1.4, 1.6, 1.8, 1.8 Syncro, 1.9 D, 1.9 SDI, 1.9 TD, 1.9 TDI, 1.9 TDI Syncro, 2.0, 2.0 Syncro, 2.9 VR6 Syncro		F8-6699		d=16; L=50; D=17
Engine Mounting	2.9 VR6 Syncro		F8-6717		
Engine Mounting	1.4	ABD	F8-6922		H=65
Bellow, driveshaft	1.4	ABD, AEX	F8-7722		d1=26; d2=78; L=110
Bellow, driveshaft	1.4, 1.9 D, 1.9 SDI		F8-7722		d1=26; d2=78; L=110
Bellow, driveshaft	1.6	AEK;	F8-7722		d1=26; d2=78; L=110
Bellow, driveshaft	1.6	AFT;	F8-7722		d1=26; d2=78; L=110
Control Arm-/Trailing Arm Bush	All Models		F8-7978		
Control Arm-/Trailing Arm Bush	1.4, 1.6, 1.8, 1.8 Syncro, 1.9 D, 1.9 SDI, 1.9 TD, 1.9 TDI, 1.9 TDI Syncro, 2.0, 2.0 Syncro, 2.9 VR6 Syncro		G9-648		H=54; d=12; D1=33; D2=36
Bellow, steering	1.4, 1.6, 1.8, 1.8 Syncro, 1.9 D, 1.9 SDI, 1.9 TD, 1.9 TDI, 1.9 TDI Syncro, 2.0, 2.0 Syncro, 2.9 VR6 Syncro	for steering gear manufacturer: TRW; with clamps;	LM-10003S		d1=9; d2=43; L [mm]=210
Bellow, steering	1.9 TDI	with clamps;	LM-10003S		d1=9; d2=43; L [mm]=210
Bellow, steering	All Models	with clamps	LM-10006S		d1=10; d2=41; L [mm]=210
Bellow, steering	1.4, 1.6, 1.8, 1.9 D, 1.9 TD, 1.9 TDI, 2.0	ch.→1H-TW500000; with clamps;	LM-10024S		d1=25; d2=41; L [mm]=120
Bellow, steering	1.4, 1.6, 1.8, 1.8 Syncro, 1.9 D, 1.9 SDI, 1.9 TD, 1.9 TDI, 1.9 TDI Syncro, 2.0, 2.0 Syncro	Manufacturer Restriction: ZF; with clamps;	LM-10029S		d1=13; d2=45; L [mm]=138
Bellow, steering	1.4, 1.6, 1.8, 1.9 D, 1.9 TD, 1.9 TDI, 2.0	ch.→1H-TW500000; with clamps;	LM-10050S		d1=25; d2=39; L [mm]=126
Bellow, driveshaft	1.4, 1.6, 1.9 D, 1.9 SDI		M-830220		



**Article Description****Article Nr.****Fitting Position**

<b>GOLF Mk III Estate (1H5)</b>				<b>07/1993 → 04/1999</b>	
Bellow Set, drive shaft	1.4	ABD, AEX	<b>MK-830220</b>		
Bellow Set, drive shaft	1.4, 1.9 D, 1.9 SDI		<b>MK-830220</b>		
Bellow Set, drive shaft	1.6	AEK, AFT;	<b>MK-830220</b>		
Bellow Set, drive shaft	1.4, 1.9 D, 1.9 SDI		<b>MK-830220S</b>		
<b>GOLF Mk IV (1J1)</b>				<b>08/1997 → 06/2005</b>	
Dust Cover Kit, shock absorber	1.4 16V, 1.6, 1.6 16V, 1.6 FSI, 1.8, 1.8 T, 1.8 T GTI, 1.9 SDI, 1.9 TDI, 1.9 TDI 4motion, 2.0, 2.0 4motion, 2.3 V5, 2.3 V5 4motion, 2.8 V6 4motion, 3.2 R32 4motion		<b>AK-735039</b>		
Dust Cover Kit, shock absorber	1.4 16V, 1.6, 1.6 16V, 1.6 FSI, 1.8, 1.8 T, 1.8 T GTI, 1.9 SDI, 1.9 TDI, 2.0, 2.3 V5		<b>AK-735095</b>		
Dust Cover Kit, shock absorber	1.4 16V, 1.6, 1.6 16V, 1.6 FSI, 1.8, 1.8 4motion, 1.8 T, 1.8 T GTI, 1.9 SDI, 1.9 TDI, 1.9 TDI 4motion, 2.0, 2.0 4motion, 2.3 V5, 2.3 V5 4motion, 2.8 V6 4motion, 3.2 R32 4motion	<b>ST</b>	<b>AK-735410</b>		H=210
Alternator Freewheel Clutch	1.6, 1.8 T GTI, 1.9 SDI, 1.9 TDI, 1.9 TDI 4motion, 2.3 V5, 2.3 V5 4motion, 2.8 V6 4motion		<b>F5-1004</b>		
Alternator Freewheel Clutch	1.9 TD		<b>F5-1007</b>		
Alternator Freewheel Clutch	1.9 SDI, 1.9 TDI, 1.9 TDI 4motion, 2.3 V5, 2.3 V5 4motion		<b>F5-1009</b>		
Anti-Friction Bearing	All Models		<b>F8-3039</b>		H=14; d1=14; D=45
Top Strut Mounting	All Models		<b>F8-4067</b>		H=53; d=26; D=82
Bellow Set, steering	1.4 16V, 1.6, 1.6 16V, 1.8, 1.8 4motion, 1.8 T, 1.9 SDI, 1.9 TDI, 1.9 TDI 4motion, 2.0, 2.3 V5, 2.3 V5 4motion, 2.8 V6 4motion	for OE: 1J0422831; for steering manufacturer: ZF	<b>F8-4074</b>		H=125; D1=34; D2=39
Bellow Set, steering	1.9 TDI 4motion	04/1998 →; for OE: 1J0422831; for steering manufacturer: ZF	<b>F8-4074</b>		H=125; D1=34; D2=39
Stabiliser Mounting	1.4 16V	ch.→1J-Y-900000;  AHW, AKQ, APE; only in connection with: F8-6579; Stabi. Diam. [mm]= 19	<b>F8-5215</b>		d=17
Stabiliser Mounting	1.6 16V	ch.→1J-Y-900000;  ATN, AUS; only in connection with: F8-6579; Stabi. Diam. [mm]= 19	<b>F8-5215</b>		d=17
Stabiliser Mounting	1.6, 1.9 SDI, 1.9 TDI, 2.3 V5	ch.→1J-Y-900000; only in connection with: F8-6579; Stabi. Diam. [mm]= 19	<b>F8-5215</b>		d=17
Stabiliser Mounting	1.8	ch.→1J-Y-900000;  AGN; only in connection with: F8-6579; Stabi. Diam. [mm]= 19	<b>F8-5215</b>		d=17
Stabiliser Mounting	1.8 T	ch.→1J-Y-900000;  AGU, ARZ; only in connection with: F8-6579; Stabi. Diam. [mm]= 19	<b>F8-5215</b>		d=17

<b>AK-735039</b>	<b>AK-735095</b>	<b>AK-735410</b>	<b>F5-1004</b>	<b>F5-1007</b>	<b>F5-1009</b>	<b>F8-3039</b>
Ref.Nr.: 357413175A	Ref.Nr.: 1J0512131B	Ref.Nr.: 1J0412303	Ref.Nr.: 038903119T	Ref.Nr.: 028903119AQ	Ref.Nr.: 038903119	Ref.Nr.: 357412249A
<b>F8-4067</b>	<b>F8-4074</b>	<b>F8-5215</b>	<b>MK-830220</b>	<b>MK-830220S</b>		
Ref.Nr.: 1J0412331B	Ref.Nr.: 171419832A	Ref.Nr.: 1J0411314B	Ref.Nr.: 171498203	Ref.Nr.:		

Article Description



Article Nr.

Fitting Position



GOLF Mk IV (1J1)			08/1997 → 06/2005		
Stabiliser Mounting	1.9 TDI	ch.→1J-Y-900000;  AHF; only in connection with: F8-6579; Stabi. Diam. [mm]= 19	F8-5215		d=17
Stabiliser Mounting	1.9 TDI	ch.→1J-Y-900000;  AJM; only in connection with: F8-6579; Stabi. Diam. [mm]= 19	F8-5215		d=17
Stabiliser Mounting	1.9 TDI	ch.→1J-Y-900000;  ATD; only in connection with: F8-6579; Stabi. Diam. [mm]= 19	F8-5215		d=17
Stabiliser Mounting	2.0	ch.→1J-Y-900000;  APK, AQY; only in connection with: F8-6579; Stabi. Diam. [mm]= 19	F8-5215		d=17
Stabiliser Mounting	3.2 R32 4motion	only in connection with: F8-6579; Stabi. Diam. [mm]= 19	F8-5215		d=17
Stabiliser Mounting	1.4 16V, 1.6, 1.8, 1.8 T, 1.9 SDI, 1.9 TDI, 2.3 V5	01/1998 →; only in connection with: F8-6579; Stabi. Diam. [mm]= 23;	F8-5220		d=21
Stabiliser Mounting	1.8 4motion, 2.0, 2.8 V6 4motion	only in connection with: F8-6579; Stabi. Diam. [mm]= 23;	F8-5220		d=21
Stabiliser Mounting	1.9 TDI 4motion	04/1998 →; only in connection with: F8-6579; Stabi. Diam. [mm]= 23;	F8-5220		d=21
Stabiliser Mounting	1.4 16V, 1.6, 1.6 16V, 1.6 FSI, 1.8, 1.8 4motion, 1.8 T, 1.8 T GTI, 1.9 SDI, 1.9 TDI, 1.9 TDI 4motion, 2.0, 2.0 4motion, 2.3 V5, 2.3 V5 4motion, 2.8 V6 4motion	only in connection with: F8-6579; Stabi. Diam. [mm]= 21	F8-5221		d=19; D=20.7
Mounting, axle beam	1.4 16V, 1.6, 1.6 16V, 1.6 FSI, 1.8, 1.8 4motion, 1.8 T, 1.8 T GTI, 1.9 SDI, 1.9 TDI, 1.9 TDI 4motion, 2.0, 2.0 4motion, 2.3 V5, 2.3 V5 4motion, 2.8 V6 4motion		F8-5340		H=90; d=12; D=72
Top Strut Mounting	1.4 16V, 1.6, 1.6 16V, 1.6 FSI, 1.8, 1.8 T, 1.8 T GTI, 1.9 SDI, 1.9 TDI, 2.0, 2.3 V5	ch.→1J-Y-500000	F8-5380		
Rubber Buffer, suspension	1.4 16V, 1.6, 1.6 16V, 1.6 FSI, 1.8, 1.8 T, 1.8 T GTI, 1.9 SDI, 1.9 TDI, 2.0, 2.3 V5		F8-5381		H=37; D=76
Stabiliser Mounting	1.4 16V, 1.6, 1.6 16V, 1.6 FSI, 1.8, 1.8 4motion, 1.8 T, 1.8 T GTI, 1.9 SDI, 1.9 TDI, 1.9 TDI 4motion, 2.0, 2.0 4motion, 2.3 V5, 2.3 V5 4motion, 2.8 V6 4motion, 3.2 R32 4motion		F8-5382		D=14
Engine Mounting	1.4 16V, 1.6, 1.6 16V, 1.8, 2.0, 2.3 V5		F8-5383		
Engine Mounting	1.9 SDI, 1.9 TDI		F8-5384		
Mounting, manual transmission	1.4 16V, 1.6		F8-5385		
Mounting, manual transmission	1.6	AVU;	F8-5385		
Mounting, manual transmission	1.6 16V		F8-5385		
Engine Mounting	1.4 16V, 1.6, 1.6 16V		F8-5386		
Engine Mounting	1.6	01/1998 →;	F8-5386		
Engine Mounting	1.8, 1.8 T, 1.9 TDI, 2.0		F8-5386		
Mounting, automatic transmission	1.8 4motion, 1.9 TDI 4motion, 2.0 4motion		F8-5387		

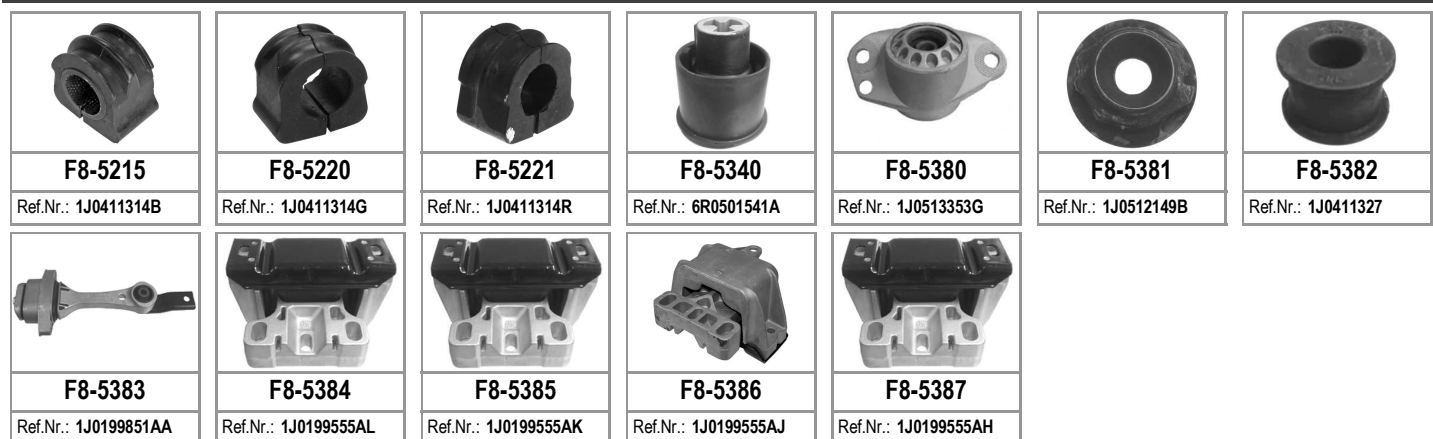



Article Description



Article Nr.

Fitting Position



GOLF Mk IV (1J1)		08/1997 → 06/2005			
Mounting, automatic transmission	1.8, 1.8 T, 1.9 TDI, 2.0		F8-5387		
Mounting, automatic transmission	1.9 TDI	AJM;  5-speed	F8-5387		
Mounting, automatic transmission	2.3 V5	5-speed	F8-5387		
Engine Mounting	1.4 16V, 1.6 16V, 1.6 FSI		F8-5388		
Engine Mounting	1.4 16V, 1.6		F8-5390		
Engine Mounting	1.6, 1.8, 1.8 T, 1.8 T GTI, 1.9 SDI, 1.9 TDI, 2.0		F8-5404		
Spring Cap	All Models		F8-5580		D=92
Belt Pulley, crankshaft	1.8, 1.8 4motion, 1.8 T, 1.8 T GTI, 2.0, 2.0 4motion		F8-5650		
Protective Cap/Bellow, shock absorber	1.4 16V, 1.6, 1.6 16V, 1.6 FSI, 1.8, 1.8 4motion, 1.8 T, 1.8 T GTI, 1.9 SDI, 1.9 TDI, 1.9 TDI 4motion, 2.0, 2.0 4motion, 2.3 V5, 2.3 V5 4motion, 2.8 V6 4motion, 3.2 R32 4motion		F8-5683		H=210
Mounting, axle beam	1.4 16V, 1.6, 1.6 16V, 1.6 FSI, 1.8, 1.8 4motion, 1.8 T, 1.8 T GTI, 1.9 SDI, 1.9 TDI, 1.9 TDI 4motion, 2.0, 2.0 4motion, 2.3 V5, 2.3 V5 4motion, 2.8 V6 4motion, 3.2 R32 4motion		F8-5907		H=31; d1=18; d2=19; D1=65; D2=56
Rubber Buffer, suspension	1.4 16V, 1.6, 1.6 16V, 1.8, 1.8 4motion, 1.8 T, 1.9 SDI, 1.9 TDI, 1.9 TDI 4motion, 2.0		F8-5996		H=63
Rubber Buffer, suspension	1.4 16V, 1.6, 1.6 16V, 1.6 FSI, 1.8, 1.8 T, 1.8 T GTI, 1.9 SDI, 1.9 TDI, 2.0, 2.3 V5, 2.8 V6 4motion		F8-6007		H=116
Rubber Buffer, suspension	1.4 16V, 1.6, 1.6 16V, 1.6 FSI, 1.8, 1.8 T, 1.8 T GTI, 1.9 SDI, 1.9 TDI, 2.0, 2.3 V5		F8-6012		H=143
Rubber Buffer, suspension	1.4 16V, 1.6, 1.6 16V, 1.8, 1.8 T, 1.9 SDI, 1.9 TDI, 2.0, 2.3 V5, 2.8 V6 4motion		F8-6013		H=128
Top Strut Mounting	1.4 16V, 1.6, 1.6 16V, 1.6 FSI, 1.8, 1.8 T, 1.8 T GTI, 1.9 SDI, 1.9 TDI, 2.0, 2.3 V5	ch.1JY500001→	F8-6040		
Rubber Buffer, suspension	1.4 16V, 1.6, 1.6 16V, 1.6 FSI, 1.8, 1.8 T, 1.8 T GTI, 1.9 SDI, 1.9 TDI, 2.0, 2.3 V5		F8-6041		H=53
Rubber Buffer, suspension	1.8 4motion, 1.9 TDI 4motion, 2.0 4motion	for OE: 1GD, 1GV, G46, G47, G75, G84, G88;	F8-6041		H=53
Rubber Buffer, suspension	2.3 V5 4motion	ch.1J-Y-360001→; for OE: 1GJ, 1GU	F8-6041		H=53
Rubber Buffer, suspension	2.3 V5 4motion, 2.8 V6 4motion	for OE: G46, G47, G75, G84, G88	F8-6041		H=53
Rubber Buffer, suspension	2.8 V6 4motion	for OE: 1GT;	F8-6041		H=53
Protective Cap/Bellow, shock absorber	1.4 16V, 1.6, 1.6 16V, 1.6 FSI, 1.8, 1.8 T, 1.8 T GTI, 1.9 SDI, 1.9 TDI, 2.0, 2.3 V5		F8-6044		H=160
Protective Cap/Bellow, shock absorber	1.4 16V, 1.6, 1.6 16V, 1.6 FSI, 1.8, 1.8 T, 1.8 T GTI, 1.9 SDI, 1.9 TDI, 2.0, 2.3 V5		F8-6045		
Mounting, axle beam	1.4 16V, 1.6, 1.6 16V, 1.6 FSI, 1.8, 1.8 T, 1.8 T GTI, 1.9 SDI, 1.9 TDI, 2.0, 2.3 V5, 2.8 V6 4motion		F8-6076		d=12; L=90; D=69

<b>F8-5387</b>	<b>F8-5388</b>	<b>F8-5390</b>	<b>F8-5404</b>	<b>F8-5580</b>	<b>F8-5650</b>	<b>F8-5683</b>
Ref.Nr.: 1J0199555AH	Ref.Nr.: 1J0199262BK	Ref.Nr.: 1J0199262BE	Ref.Nr.: 1J0199262BF	Ref.Nr.: 1J0412341	Ref.Nr.: 06A105243E	Ref.Nr.: 357413175A
<b>F8-5907</b>	<b>F8-5996</b>	<b>F8-6007</b>	<b>F8-6012</b>	<b>F8-6013</b>	<b>F8-6040</b>	<b>F8-6041</b>
Ref.Nr.: 1J0199429	Ref.Nr.: 1H0412303B	Ref.Nr.: 1J0512131C	Ref.Nr.: 1J0512131	Ref.Nr.: 1J0412131B	Ref.Nr.: 1J0513353D	Ref.Nr.: 1J0412303
<b>F8-6044</b>	<b>F8-6045</b>	<b>F8-6076</b>	<b>F8-6077</b>			
Ref.Nr.: 3C0513425	Ref.Nr.: 1J0513425A	Ref.Nr.: 1J0501541D	Ref.Nr.: 1J0501541DS			

Article Description



Article Nr.

Fitting Position



**GOLF Mk IV (1J1)**

08/1997 → 06/2005

Repair Set, axle beam	1.4 16V, 1.6, 1.6 16V, 1.6 FSI, 1.8 T GTI, 1.9 SDI, 1.9 TDI, 2.0, 2.3 V5		<b>F8-6077</b>		H=90; D=69
Repair Set, axle beam	1.6	BFQ	<b>F8-6077</b>		H=90; D=69
Repair Set, axle beam	1.8	AGN	<b>F8-6077</b>		H=90; D=69
Repair Set, axle beam	1.8 T	ARZ	<b>F8-6077</b>		H=90; D=69
Top Strut Mounting	All Models		<b>F8-6280</b>		H=53; d=26; D=82
Belt Pulley, crankshaft	1.9 TDI, 1.9 TDI 4motion	ch.→1J-4D008311, 1J-4U001138, 1J-4W040231; Number of Ribs: 5; Parameter: 6PK	<b>F8-6392</b>		H=47; d=30; D=143
Belt Pulley, crankshaft	1.9 TDI, 1.9 TDI 4motion	ch.→1J-6-005000; Number of Ribs: 5; Parameter: 6PK	<b>F8-6392</b>		H=47; d=30; D=143
Belt Pulley, crankshaft	1.9 TDI, 1.9 TDI 4motion	Number of Ribs: 5; Parameter: 6PK	<b>F8-6392</b>		H=47; d=30; D=143
Belt Pulley, crankshaft	1.9 SDI	ch.1J-3B075001, 1J-3B350001, 1J-3D016001, 1J-3P066001, 1J-3U205001→;  AQM; Number of Ribs: 5; Parameter: 6PK	<b>F8-6396</b>		H=41.6; d=30; Mounting points diam.[mm]=7, 8.6; D=139.7
Belt Pulley, crankshaft	1.9 TDI, 1.9 TDI 4motion	ch.1J-3B075001, 1J-3B350001, 1J-3D016001, 1J-3P066001, 1J-3U205001→; Number of Ribs: 5; Parameter: 6PK	<b>F8-6396</b>		H=41.6; d=30; Mounting points diam.[mm]=7, 8.6; D=139.7
Belt Pulley, crankshaft	1.9 TDI, 1.9 TDI 4motion	ch.1J-4D008312, 1J-4U001139, 1J-4W040232→; Number of Ribs: 5; Parameter: 6PK	<b>F8-6396</b>		H=41.6; d=30; Mounting points diam.[mm]=7, 8.6; D=139.7
Belt Pulley, crankshaft	1.9 TDI, 1.9 TDI 4motion	ch.1J-6-005001→; Number of Ribs: 5; Parameter: 6PK	<b>F8-6396</b>		H=41.6; d=30; Mounting points diam.[mm]=7, 8.6; D=139.7
Control Arm-/Trailing Arm Bush	3.2 R32 4motion		<b>F8-6464</b>		H=41; d=13,5; W=60
Bracket, stabilizer mounting	1.4 16V, 1.6, 1.6 16V, 1.6 FSI, 1.8 4motion, 1.8 T, 1.8 T GTI, 1.9 SDI, 1.9 TDI, 1.9 TDI 4motion, 2.0, 2.0 4motion, 2.3 V5, 2.3 V5 4motion, 2.8 V6 4motion		<b>F8-6579</b>		
Bracket, stabilizer mounting	1.6	AVU, BFQ	<b>F8-6579</b>		
Bracket, stabilizer mounting	1.8	AGN	<b>F8-6579</b>		
Bracket, stabilizer mounting	3.2 R32 4motion	BFH	<b>F8-6579</b>		
Control Arm-/Trailing Arm Bush	3.2 R32 4motion	BFH	<b>F8-6775</b>		H=54; d=12; D=45
Engine Mounting	1.9 TDI, 1.9 TDI 4motion		<b>F8-6960</b>		
Mounting, axle bracket	1.8 4motion, 1.9 TDI 4motion, 2.0 4motion, 2.3 V5 4motion, 2.8 V6 4motion, 3.2 R32 4motion	ch.→1J-4-00001	<b>F8-7046</b>		H=55; d=16; D=52
Mounting, axle bracket	1.9 TDI 4motion, 2.3 V5 4motion		<b>F8-7046</b>		H=55; d=16; D=52
Top Strut Mounting	All Models	for OE: 1J0412319C	<b>F8-7133</b>		
Belt Pulley, crankshaft	1.9 SDI, 1.9 TDI, 1.9 TDI 4motion	ch.→1J-3B075000, 1J-3D016000, 1J-3P066000, 1J-3U205000, 1J-3W350000	<b>F8-7864</b>		
Stabiliser Mounting	1.8 4motion, 1.9 TDI 4motion, 2.3 V5 4motion	ch.1J-Y-000 001→; for OE: 0AR	<b>F8-7901</b>		





**Article Description****Article Nr.****Fitting Position****GOLF Mk IV (1J1) 08/1997 → 06/2005**

Stabiliser Mounting	1.9 TDI 4motion	ch.1J-Y-000 001→; ch.→1J-4-220000; <small>AGR</small> AGR; for OE: 0AR	<b>F8-7901</b>		
Stabiliser Mounting	1.9 TDI 4motion, 2.0 4motion, 2.3 V5 4motion, 2.8 V6 4motion	ch.1J-Y-000 001→; ch.→1J-4-220000; for OE: 0AR	<b>F8-7901</b>		
Stabiliser Mounting	1.8 4motion, 1.9 TDI 4motion, 2.0 4motion, 2.3 V5 4motion, 2.8 V6 4motion		<b>F8-7927</b>		d=18
Stabiliser Mounting	1.4 16V, 1.6, 1.8, 1.9 TDI, 2.0		<b>F8-7936</b>		
Control Arm-/Trailing Arm Bush	1.0, 1.4 16V, 1.6, 1.6 16V, 1.6 D, 1.6 FSI, 1.8, 1.8 4motion, 1.8 T, 1.8 T GTI, 1.9 SDI, 1.9 TD, 1.9 TDI, 1.9 TDI 4motion, 2.0, 2.0 4motion, 2.3 V5, 2.3 V5 4motion, 2.8 V6 4motion		<b>F8-7978</b>		
Engine Mounting	1.4 16V		<b>F8-8198</b>		
Control Arm-/Trailing Arm Bush	1.4 16V, 1.6, 1.6 16V, 1.6 FSI, 1.8, 1.8 4motion, 1.8 T, 1.8 T GTI, 1.9 SDI, 1.9 TDI, 1.9 TDI 4motion, 2.0, 2.0 4motion, 2.3 V5, 2.3 V5 4motion, 2.8 V6 4motion		<b>G9-648</b>		H=54; d=12; D1=33; D2=36
Control Arm-/Trailing Arm Bush	1.4 16V, 1.6, 1.6 16V, 1.6 FSI, 1.8, 1.8 4motion, 1.8 T, 1.8 T GTI, 1.9 SDI, 1.9 TDI, 1.9 TDI 4motion, 2.0, 2.0 4motion, 2.3 V5, 2.3 V5 4motion, 2.8 V6 4motion		<b>G9-649</b>		H1=25; H2=41; d=13; D=60
Bellow, steering	All Models	with clamps;	<b>LM-10020S</b>		d1=16; d2=48; L [mm]=179
Bellow Set, drive shaft	1.8 T	09/2000 →;  AUM; with clamps;	<b>MK-810160</b>		L=116
Bellow Set, drive shaft	1.9 TDI, 2.3 V5, 2.3 V5 4motion	with clamps;	<b>MK-810160</b>		L=116

**GOLF Mk III Convertible (1E7) 06/1998 → 06/2002**

Dust Cover Kit, shock absorber	All Models	△	<b>AK-732516</b>		
Dust Cover Kit, shock absorber	All Models		<b>AK-733023</b>		
Dust Cover Kit, shock absorber	All Models	<b>ST</b>	<b>AK-735410</b>		H=210
Alternator Freewheel Clutch	1.9 TDI		<b>F5-1007</b>		
Control Arm-/Trailing Arm Bush	All Models	without guide sleeve	<b>F8-1007</b>		H1=26; H2=41; d=17; D1=60; D2=68
Control Arm-/Trailing Arm Bush	All Models	with guide sleeve	<b>F8-1007S</b>		H1=26; H2=41; d=17; D1=60; D2=68
Repair Kit, link	1.6, 1.8, 1.9 TDI, 2.0	with guide sleeve	<b>F8-1008</b>		H1=24; H2=41; d=17; D=60
Top Strut Mounting	All Models		<b>F8-1034</b>		H=50; d=27; D=98
Top Strut Mounting	All Models		<b>F8-1034S</b>		H=51; d=14; D=96
Anti-Friction Bearing	All Models		<b>F8-3039</b>		H=14; d1=14; D=45
Stabiliser Mounting	1.8		<b>F8-3042</b>		H=33; d=17; W=35
Repair Set, axle beam	All Models	with fastening material	<b>F8-4008S</b>		H1=54; H2=90; d=12; D=56
Holder, exhaust system	1.6, 1.9 TDI, 2.0		<b>F8-4025</b>		H=65; T [mm]=86; W=35
Bellow, steering	All Models		<b>F8-4076</b>		H=151; D1=20; D2=55
Engine Mounting	1.6	Brown;  AFT	<b>F8-5346</b>		
Engine Mounting	2.0	Brown;  AGG	<b>F8-5346</b>		

<b>AK-732516</b>	<b>AK-733023</b>	<b>AK-735410</b>	<b>F5-1007</b>	<b>F8-1007</b>	<b>F8-1007S</b>	<b>F8-1008</b>
Ref.Nr.:	Ref.Nr.: 191412303	Ref.Nr.: 1J0412303	Ref.Nr.: 028903119AQ	Ref.Nr.: 191407181A	Ref.Nr.: 191407181A	Ref.Nr.: 191407181E
<b>F8-1034</b>	<b>F8-1034S</b>	<b>F8-3039</b>	<b>F8-3042</b>	<b>F8-4008S</b>	<b>F8-4025</b>	<b>F8-4076</b>
Ref.Nr.: 357412331A	Ref.Nr.: 7201848S1	Ref.Nr.: 357412249A	Ref.Nr.: 191411314	Ref.Nr.: 1H0501541	Ref.Nr.: 1H0253144	Ref.Nr.: 357422831B
<b>F8-5346</b>	<b>F8-5362</b>	<b>F8-7901</b>	<b>F8-7927</b>	<b>F8-7936</b>	<b>F8-7978</b>	<b>F8-8198</b>
Ref.Nr.: 1H0199609G	Ref.Nr.: 191512113	Ref.Nr.: 1J0411314P	Ref.Nr.: 1J0411314AC	Ref.Nr.: 1J0411327A	Ref.Nr.: 357407182F	Ref.Nr.: 1J0199555BD

Article Description



Article Nr.

Fitting Position



GOLF Mk III Convertible (1E7)			06/1998 → 06/2002	
Spring Cap	All Models		F8-5362	
Stabiliser Mounting	All Models		F8-5382	D=14
Spring Mounting	All Models		F8-5393	
Mounting, steering gear	All Models		F8-5394	
Stabiliser Mounting	1.8	ADZ; Stabi. Diam. [mm]= 21.5	F8-5395	d=19
Engine Mounting	1.9 TDI	AHU	F8-5396	
Engine Mounting	1.8	AAM;	F8-5397	
Engine Mounting	1.8	ADZ;	F8-5397	
Engine Mounting	1.8		F8-5398	
Engine Mounting	1.9 TDI		F8-5399	
Top Strut Mounting	All Models		F8-5402	
Top Strut Mounting	All Models		F8-5403	
Engine Mounting	1.9 TDI		F8-5491	
Engine Mounting	1.9 TDI	AFN	F8-5491	
Rubber Buffer, suspension	All Models		F8-5594	H=146; d=10.5; D=55.6
Belt Pulley, crankshaft	1.9 TDI	Number of Ribs: 5; Parameter: 6PK	F8-5649	H=31.5; d=30.02; Mounting points diam.[mm]=8.5; D1=161.5; D2=160.5
Holder, engine mounting	All Models		F8-5672	H=39.5; D=24
Protective Cap/Bellow, shock absorber	All Models		F8-5683	H=210
Protective Cap/Bellow, shock absorber	All Models		F8-5747	H=90
Rubber Buffer, suspension	All Models		F8-5993	H=83
Repair Kit, suspension strut	All Models		F8-6382	
Sleeve, control arm mounting	1.6, 1.9 TDI, 2.0		F8-6699	d=16; L=50; D=17
Engine Mounting	1.8	ch.→1E-2-015000;  ANN	F8-6922	H=65
Engine Mounting	1.8	ch.→1E-2-015000;  ANP	F8-6922	H=65
Engine Mounting	2.0	ch.1E-2-800001→; ch.→1E-2-015000;  AGG, AKR, ATU, AWF, AWG	F8-6922	H=65
Bellow, driveshaft	1.6	AFT	F8-7722	d1=26; d2=78; L=110
Bellow, driveshaft	1.8	ADZ	F8-7722	d1=26; d2=78; L=110
Bellow, driveshaft	1.9 TDI	AHU	F8-7722	d1=26; d2=78; L=110
Stabiliser Mounting	1.6, 1.9 TDI, 2.0		F8-7936	
Control Arm-/Trailing Arm Bush	1.6, 1.8, 1.9 TDI		F8-7978	
Control Arm-/Trailing Arm Bush	All Models		G9-648	H=54; d=12; D1=33; D2=36



**Article Description****Article Nr.****Fitting Position**

<b>GOLF Mk III Convertible (1E7)</b>			<b>06/1998 → 06/2002</b>		
Bellow, driveshaft	1.6, 1.9 TDI		<b>M-830220</b>		
Bellow Set, drive shaft	1.6	AFT	<b>MK-830220</b>		
Bellow Set, drive shaft	1.8	ADZ	<b>MK-830220</b>		
Bellow Set, drive shaft	1.9 TDI	AHU	<b>MK-830220</b>		
<b>GOLF Mk IV Estate (1J5)</b>			<b>05/1999 → 06/2006</b>		
Dust Cover Kit, shock absorber	1.4 16V, 1.6, 1.6 16V, 1.6 FSI, 1.8 4motion, 1.8 T, 1.9 SDI, 1.9 TDI, 1.9 TDI 4motion, 2.0, 2.0 4motion, 2.0 Bi-Fuel, 2.3 V5, 2.3 V5 4motion, 2.8 V6 4motion		<b>AK-735039</b>		
Dust Cover Kit, shock absorber	1.4 16V, 1.6, 1.6 16V, 1.6 FSI, 1.8 T, 1.9 SDI, 1.9 TDI, 2.0, 2.0 Bi-Fuel, 2.3 V5		<b>AK-735095</b>		
Dust Cover Kit, shock absorber	1.4 16V, 1.6, 1.6 16V, 1.6 FSI, 1.8 4motion, 1.8 T, 1.9 SDI, 1.9 TDI, 1.9 TDI 4motion, 2.0, 2.0 4motion, 2.0 Bi-Fuel, 2.3 V5, 2.3 V5 4motion, 2.8 V6 4motion	ST	<b>AK-735410</b>		H=210
Alternator Freewheel Clutch	1.6, 1.9 SDI, 1.9 TDI, 1.9 TDI 4motion, 2.0 Bi-Fuel, 2.3 V5, 2.3 V5 4motion, 2.8 V6 4motion		<b>F5-1004</b>		
Alternator Freewheel Clutch	1.9 SDI, 1.9 TDI, 1.9 TDI 4motion, 2.3 V5, 2.3 V5 4motion		<b>F5-1009</b>		
Anti-Friction Bearing	1.4 16V, 1.6, 1.6 16V, 1.6 FSI, 1.8 4motion, 1.8 T, 1.9 SDI, 1.9 TDI, 1.9 TDI 4motion, 2.0, 2.0 4motion, 2.0 Bi-Fuel, 2.3 V5, 2.3 V5 4motion, 2.8 V6 4motion		<b>F8-3039</b>		H=14; d1=14; D=45
Top Strut Mounting	1.4 16V, 1.6, 1.6 16V, 1.6 FSI, 1.8 4motion, 1.8 T, 1.9 SDI, 1.9 TDI, 1.9 TDI 4motion, 2.0, 2.0 4motion, 2.0 Bi-Fuel, 2.3 V5, 2.3 V5 4motion, 2.8 V6 4motion		<b>F8-4067</b>		H=53; d=26; D=82
Bellow Set, steering	1.4 16V, 1.6, 1.6 16V, 1.8 4motion, 1.9 SDI, 1.9 TDI, 1.9 TDI 4motion, 2.0, 2.3 V5, 2.3 V5 4motion, 2.8 V6 4motion	for OE: 1J0422831; for steering manufacturer: ZF	<b>F8-4074</b>		H=125; D1=34; D2=39
Stabiliser Mounting	1.4 16V	01/2001 →;  AXP, BCA; only in connection with: F8-6579; Stabi. Diam. [mm]= 19	<b>F8-5215</b>		d=17
Stabiliser Mounting	1.6	AEH, AKL; only in connection with: F8-6579; Stabi. Diam. [mm]= 19	<b>F8-5215</b>		d=17
Stabiliser Mounting	1.6 16V	01/2001 →;  AUS, BCB; only in connection with: F8-6579; Stabi. Diam. [mm]= 19	<b>F8-5215</b>		d=17
Stabiliser Mounting	1.6 FSI, 1.8 T, 1.9 TDI, 2.3 V5	only in connection with: F8-6579; Stabi. Diam. [mm]= 19	<b>F8-5215</b>		d=17
Stabiliser Mounting	1.9 SDI	AQM; only in connection with: F8-6579; Stabi. Diam. [mm]= 19	<b>F8-5215</b>		d=17
Stabiliser Mounting	1.9 TDI	01/2001 →; only in connection with: F8-6579; Stabi. Diam. [mm]= 19	<b>F8-5215</b>		d=17
Stabiliser Mounting	1.9 TDI	AUJ; only in connection with: F8-6579; Stabi. Diam. [mm]= 19	<b>F8-5215</b>		d=17
Stabiliser Mounting	2.0	01/2001 →;  AQY, AZJ; only in connection with: F8-6579; Stabi. Diam. [mm]= 19	<b>F8-5215</b>		d=17



Article Description



Article Nr.

Fitting Position



<b>GOLF Mk IV Estate (1J5)</b>			<b>05/1999 → 06/2006</b>		
Stabiliser Mounting	1.4 16V, 1.6, 1.9 SDI, 1.9 TDI, 2.0, 2.3 V5	only in connection with: F8-6579; Stabi. Diam. [mm]= 23;	<b>F8-5220</b>		d=21
Stabiliser Mounting	1.4 16V, 1.6, 1.6 16V, 1.6 FSI, 1.9 SDI, 1.9 TDI, 2.0, 2.3 V5	only in connection with: F8-6579; Stabi. Diam. [mm]= 21	<b>F8-5221</b>		d=19; D=20.7
Mounting, axle beam	1.4 16V, 1.6, 1.6 16V, 1.6 FSI, 1.8 4motion, 1.9 SDI, 1.9 TDI, 1.9 TDI 4motion, 2.0, 2.0 4motion, 2.3 V5, 2.8 V6 4motion		<b>F8-5340</b>		H=90; d=12; D=72
Top Strut Mounting	1.4 16V, 1.6, 1.6 16V, 1.8 T, 1.9 SDI, 1.9 TDI, 2.0, 2.3 V5		<b>F8-5380</b>		
Rubber Buffer, suspension	1.4 16V, 1.6, 1.6 16V, 1.6 FSI, 1.8 T, 1.9 SDI, 1.9 TDI, 2.0, 2.0 Bi-Fuel, 2.3 V5		<b>F8-5381</b>		H=37; D=76
Stabiliser Mounting	1.4 16V, 1.6, 1.6 16V, 1.6 FSI, 1.8 4motion, 1.8 T, 1.9 SDI, 1.9 TDI, 1.9 TDI 4motion, 2.0, 2.0 4motion, 2.0 Bi-Fuel, 2.3 V5, 2.3 V5 4motion, 2.8 V6 4motion		<b>F8-5382</b>		D=14
Engine Mounting	1.4 16V, 1.6, 1.6 16V, 1.8 4motion, 2.0, 2.3 V5		<b>F8-5383</b>		
Engine Mounting	1.9 SDI, 1.9 TDI		<b>F8-5384</b>		
Mounting, manual transmission	1.4 16V, 1.6		<b>F8-5385</b>		
Mounting, manual transmission	1.6, 1.6 16V		<b>F8-5385</b>		
Engine Mounting	1.4 16V, 1.6, 1.6 16V		<b>F8-5386</b>		
Engine Mounting	1.8 4motion, 1.9 TDI, 1.9 TDI 4motion, 2.0		<b>F8-5386</b>		
Mounting, automatic transmission	1.8 4motion, 1.9 TDI 4motion, 2.0 4motion		<b>F8-5387</b>		
Mounting, automatic transmission	1.8 T	01/2002 →;  AGU;  4-speed	<b>F8-5387</b>		
Mounting, automatic transmission	1.9 TDI	AJM;  5-speed	<b>F8-5387</b>		
Mounting, automatic transmission	1.9 TDI, 2.0		<b>F8-5387</b>		
Mounting, automatic transmission	2.3 V5	5-speed	<b>F8-5387</b>		
Engine Mounting	1.4 16V, 1.6 16V, 1.6 FSI		<b>F8-5388</b>		
Engine Mounting	1.4 16V, 1.6		<b>F8-5390</b>		
Engine Mounting	1.6, 1.8 4motion, 1.8 T, 1.9 SDI, 1.9 TDI, 1.9 TDI 4motion, 2.0		<b>F8-5404</b>		
Spring Cap	1.4 16V, 1.6, 1.6 16V, 1.6 FSI, 1.8 4motion, 1.8 T, 1.9 SDI, 1.9 TDI, 1.9 TDI 4motion, 2.0, 2.0 4motion, 2.0 Bi-Fuel, 2.3 V5, 2.3 V5 4motion, 2.8 V6 4motion		<b>F8-5580</b>		D=92
Belt Pulley, crankshaft	1.8 4motion, 1.8 T, 2.0, 2.0 4motion, 2.0 Bi-Fuel		<b>F8-5650</b>		
Protective Cap/Bellow, shock absorber	1.4 16V, 1.6, 1.6 16V, 1.6 FSI, 1.8 4motion, 1.8 T, 1.9 SDI, 1.9 TDI, 1.9 TDI 4motion, 2.0, 2.0 4motion, 2.0 Bi-Fuel, 2.3 V5, 2.3 V5 4motion, 2.8 V6 4motion		<b>F8-5683</b>		H=210

<b>F8-5220</b>	<b>F8-5221</b>	<b>F8-5340</b>	<b>F8-5380</b>	<b>F8-5381</b>	<b>F8-5382</b>	<b>F8-5383</b>
Ref.Nr.: 1J0411314G	Ref.Nr.: 1J0411314R	Ref.Nr.: 6R0501541A	Ref.Nr.: 1J0513353G	Ref.Nr.: 1J0512149B	Ref.Nr.: 1J0411327	Ref.Nr.: 1J0199851AA
<b>F8-5384</b>	<b>F8-5385</b>	<b>F8-5386</b>	<b>F8-5387</b>	<b>F8-5388</b>	<b>F8-5390</b>	<b>F8-5404</b>
Ref.Nr.: 1J0199555AL	Ref.Nr.: 1J0199555AK	Ref.Nr.: 1J0199555AJ	Ref.Nr.: 1J0199555AH	Ref.Nr.: 1J0199262BK	Ref.Nr.: 1J0199262BE	Ref.Nr.: 1J0199262BF
<b>F8-5580</b>	<b>F8-5650</b>	<b>F8-5683</b>	<b>F8-5907</b>			
Ref.Nr.: 1J0412341	Ref.Nr.: 06A105243E	Ref.Nr.: 357413175A	Ref.Nr.: 1J0199429			

**Article Description****Article Nr.****Fitting Position**

<b>GOLF Mk IV Estate (1J5)</b>			<b>05/1999 → 06/2006</b>		
Mounting, axle beam	1.4 16V, 1.6, 1.6 16V, 1.6 FSI, 1.8 4motion, 1.8 T, 1.9 SDI, 1.9 TDI, 1.9 TDI 4motion, 2.0, 2.0 4motion, 2.0 Bi-Fuel, 2.3 V5, 2.3 V5 4motion, 2.8 V6 4motion		<b>F8-5907</b>		H=31; d1=18; d2=19; D1=65; D2=56
Rubber Buffer, suspension	1.4 16V, 1.6, 1.6 16V, 1.8 4motion, 1.8 T, 1.9 SDI, 1.9 TDI, 1.9 TDI 4motion, 2.0	<b>ST</b>	<b>F8-5996</b>		H=63
Rubber Buffer, suspension	1.4 16V, 1.6, 1.6 16V, 1.6 FSI, 1.8 T, 1.9 SDI, 1.9 TDI, 2.0, 2.0 Bi-Fuel, 2.3 V5, 2.8 V6 4motion	<b>SP</b>	<b>F8-6007</b>		H=116
Rubber Buffer, suspension	1.4 16V, 1.6, 1.6 16V, 1.6 FSI, 1.8 T, 1.9 SDI, 1.9 TDI, 2.0, 2.3 V5, 2.8 V6 4motion	<b>Δ</b>	<b>F8-6012</b>		H=143
Top Strut Mounting	1.4 16V, 1.6, 1.6 16V, 1.6 FSI, 1.8 T, 1.9 SDI, 1.9 TDI, 2.0, 2.3 V5	ch.1JY500001→	<b>F8-6040</b>		
Rubber Buffer, suspension	1.4 16V, 1.6, 1.6 16V, 1.6 FSI, 1.8 T, 1.9 SDI, 1.9 TDI, 2.0, 2.3 V5	<b>SP</b>	<b>F8-6041</b>		H=53
Rubber Buffer, suspension	1.8 4motion, 1.9 TDI 4motion, 2.0 4motion	for OE: 1GD, 1GV, G46, G47, G75, G84, G88; <b>SP</b>	<b>F8-6041</b>		H=53
Rubber Buffer, suspension	2.3 V5 4motion	ch.1J-Y-360001→; for OE: 1GJ, 1GU	<b>F8-6041</b>		H=53
Rubber Buffer, suspension	2.3 V5 4motion, 2.8 V6 4motion	for OE: G46, G47, G75, G84, G88	<b>F8-6041</b>		H=53
Rubber Buffer, suspension	2.8 V6 4motion	for OE: 1GT; <b>SP</b>	<b>F8-6041</b>		H=53
Protective Cap/Bellow, shock absorber	1.4 16V, 1.6, 1.6 16V, 1.6 FSI, 1.8 T, 1.9 SDI, 1.9 TDI, 2.0, 2.3 V5	<b>Δ</b>	<b>F8-6044</b>		H=160
Protective Cap/Bellow, shock absorber	2.0 Bi-Fuel	for OE: 1JG, 1JH; <b>Δ</b> , <b>ST</b>	<b>F8-6044</b>		H=160
Protective Cap/Bellow, shock absorber	1.4 16V, 1.6, 1.6 16V, 1.6 FSI, 1.8 T, 1.9 SDI, 1.9 TDI, 2.0, 2.3 V5		<b>F8-6045</b>		
Mounting, axle beam	1.4 16V, 1.6, 1.6 16V, 1.6 FSI, 1.8 T, 1.9 SDI, 1.9 TDI, 2.0, 2.0 Bi-Fuel, 2.3 V5		<b>F8-6076</b>		d=12; L=90; D=69
Repair Set, axle beam	1.4 16V, 1.6, 1.6 16V, 1.6 FSI, 1.9 SDI, 1.9 TDI, 2.0, 2.0 Bi-Fuel, 2.3 V5		<b>F8-6077</b>		H=90; D=69
Repair Set, axle beam	1.8 T	AGU	<b>F8-6077</b>		H=90; D=69
Top Strut Mounting	1.4 16V, 1.6, 1.6 16V, 1.6 FSI, 1.8 4motion, 1.8 T, 1.9 SDI, 1.9 TDI, 1.9 TDI 4motion, 2.0, 2.0 4motion, 2.0 Bi-Fuel, 2.3 V5, 2.3 V5 4motion, 2.8 V6 4motion		<b>F8-6280</b>		H=53; d=26; D=82
Belt Pulley, crankshaft	1.9 TDI, 1.9 TDI 4motion	ch.→1J-4D008311, 1J-4U001138, 1J-4W040231; Number of Ribs: 5; Parameter: 6PK	<b>F8-6392</b>		H=47; d=30; D=143
Belt Pulley, crankshaft	1.9 TDI, 1.9 TDI 4motion	ch.→1J-6-005000; Number of Ribs: 5; Parameter: 6PK	<b>F8-6392</b>		H=47; d=30; D=143
Belt Pulley, crankshaft	1.9 TDI, 1.9 TDI 4motion	Number of Ribs: 5; Parameter: 6PK	<b>F8-6392</b>		H=47; d=30; D=143
Belt Pulley, crankshaft	1.9 SDI	ch.1J-3B075001, 1J-3B350001, 1J-3D016001, 1J-3P066001, 1J-3U205001→;  AQM; Number of Ribs: 5; Parameter: 6PK	<b>F8-6396</b>		H=41.6; d=30; Mounting points diam.[mm]=7, 8.6; D=139.7

<b>F8-5907</b>	<b>F8-5996</b>	<b>F8-6007</b>	<b>F8-6012</b>	<b>F8-6040</b>	<b>F8-6041</b>	<b>F8-6044</b>
Ref.Nr.: 1J0199429	Ref.Nr.: 1H0412303B	Ref.Nr.: 1J0512131C	Ref.Nr.: 1J0512131	Ref.Nr.: 1J0513353D	Ref.Nr.: 1J0412303	Ref.Nr.: 3C0513425
<b>F8-6045</b>	<b>F8-6076</b>	<b>F8-6077</b>	<b>F8-6280</b>	<b>F8-6392</b>	<b>F8-6396</b>	
Ref.Nr.: 1J0513425A	Ref.Nr.: 1J0501541D	Ref.Nr.: 1J0501541DS	Ref.Nr.: 6R0412249	Ref.Nr.: 038105243	Ref.Nr.: 03G105243	

Article Description



Article Nr.

Fitting Position



**GOLF Mk IV Estate (1J5)**

05/1999 → 06/2006

Belt Pulley, crankshaft	1.9 TDI, 1.9 TDI 4motion	ch.1J-3B075001, 1J-3B350001, 1J-3D016001, 1J-3P066001, 1J-3U205001→; Number of Ribs: 5; Parameter: 6PK	<b>F8-6396</b>		H=41.6; d=30; Mounting points diam.[mm]=7, 8.6; D=139.7
Belt Pulley, crankshaft	1.9 TDI, 1.9 TDI 4motion	ch.1J-4D008312, 1J-4U001139, 1J-4W040232→; Number of Ribs: 5; Parameter: 6PK	<b>F8-6396</b>		H=41.6; d=30; Mounting points diam.[mm]=7, 8.6; D=139.7
Belt Pulley, crankshaft	1.9 TDI, 1.9 TDI 4motion	ch.1J-6-005001→; Number of Ribs: 5; Parameter: 6PK	<b>F8-6396</b>		H=41.6; d=30; Mounting points diam.[mm]=7, 8.6; D=139.7
Bracket, stabilizer mounting	1.4 16V, 1.6, 1.6 16V, 1.6 FSI, 1.8 4motion, 1.8 T, 1.9 SDI, 1.9 TDI, 1.9 TDI 4motion, 2.0, 2.0 4motion, 2.0 Bi-Fuel, 2.3 V5, 2.3 V5 4motion, 2.8 V6 4motion		<b>F8-6579</b>		
Engine Mounting	1.9 TDI, 1.9 TDI 4motion		<b>F8-6960</b>		
Mounting, axle bracket	1.8 4motion, 1.9 TDI 4motion, 2.0 4motion, 2.3 V5 4motion, 2.8 V6 4motion	ch.→1J-4-000001	<b>F8-7046</b>		H=55; d=16; D=52
Mounting, axle bracket	1.9 TDI 4motion		<b>F8-7046</b>		H=55; d=16; D=52
Top Strut Mounting	1.4 16V, 1.6, 1.6 16V, 1.6 FSI, 1.8 4motion, 1.8 T, 1.9 SDI, 1.9 TDI, 1.9 TDI 4motion, 2.0, 2.0 4motion, 2.0 Bi-Fuel, 2.3 V5, 2.3 V5 4motion, 2.8 V6 4motion	for OE: 1J0412319C	<b>F8-7133</b>		
Belt Pulley, crankshaft	1.9 SDI, 1.9 TDI, 1.9 TDI 4motion	ch.→1J-3B075000, 1J-3D016000, 1J-3P066000, 1J-3U205000, 1J-3W350000	<b>F8-7864</b>		
Stabiliser Mounting	1.8 4motion, 1.9 TDI 4motion, 2.3 V5 4motion	ch.1J-Y-000 001→; for OE: 0AR	<b>F8-7901</b>		
Stabiliser Mounting	1.9 TDI 4motion	ch.1J-Y-000 001→; ch.→1J-4-220000;  AGR; for OE: 0AR	<b>F8-7901</b>		
Stabiliser Mounting	1.9 TDI 4motion, 2.0 4motion, 2.3 V5 4motion, 2.8 V6 4motion	ch.1J-Y-000 001→; ch.→1J-4-220000; for OE: 0AR	<b>F8-7901</b>		
Stabiliser Mounting	1.8 4motion, 1.9 TDI 4motion, 2.0 4motion, 2.3 V5 4motion, 2.8 V6 4motion		<b>F8-7927</b>		d=18
Stabiliser Mounting	1.4 16V, 1.6, 1.9 TDI, 2.0		<b>F8-7936</b>		
Control Arm-/Trailing Arm Bush	1.4 16V, 1.6, 1.6 16V, 1.6 FSI, 1.8 4motion, 1.8 T, 1.9 SDI, 1.9 TDI, 1.9 TDI 4motion, 2.0, 2.0 4motion, 2.0 Bi-Fuel, 2.3 V5, 2.3 V5 4motion, 2.8 V6 4motion		<b>F8-7978</b>		
Engine Mounting	1.4 16V		<b>F8-8198</b>		
Control Arm-/Trailing Arm Bush	1.4 16V, 1.6, 1.6 16V, 1.6 FSI, 1.8 4motion, 1.9 SDI, 1.9 TDI, 1.9 TDI 4motion, 2.0, 2.0 4motion, 2.0 Bi-Fuel, 2.3 V5, 2.3 V5 4motion, 2.8 V6 4motion		<b>G9-648</b>		H=54; d=12; D1=33; D2=36
Control Arm-/Trailing Arm Bush	1.4 16V, 1.6, 1.6 16V, 1.8 4motion, 1.9 SDI, 1.9 TDI, 1.9 TDI 4motion, 2.0, 2.0 4motion, 2.3 V5, 2.3 V5 4motion, 2.8 V6 4motion		<b>G9-649</b>		H1=25; H2=41; d=13; D=60
Bellow, steering	1.4 16V, 1.6, 1.6 16V, 1.6 FSI, 1.8 4motion, 1.8 T, 1.9 SDI, 1.9 TDI, 1.9 TDI 4motion, 2.0, 2.0 4motion, 2.0 Bi-Fuel, 2.3 V5, 2.3 V5 4motion, 2.8 V6 4motion	with clamps;	<b>LM-10020S</b>		d1=16; d2=48; L [mm]=179
Bellow Set, drive shaft	1.8 T	09/2000 →;  AUM; with clamps;	<b>MK-810160</b>		L=116
Bellow Set, drive shaft	1.9 TDI, 2.3 V5, 2.3 V5 4motion	with clamps;	<b>MK-810160</b>		L=116

<b>F8-6396</b>	<b>F8-6579</b>	<b>F8-6960</b>	<b>F8-7046</b>	<b>F8-7133</b>	<b>F8-7864</b>	<b>F8-7901</b>
Ref.Nr.: 03G105243	Ref.Nr.: 1J0 411 336 C	Ref.Nr.: 1J0199262P	Ref.Nr.: 1J0505145B	Ref.Nr.: 1J0412319C	Ref.Nr.: 038 105 243	Ref.Nr.: 1J0411314P
<b>F8-7927</b>	<b>F8-7936</b>	<b>F8-7978</b>	<b>F8-8198</b>	<b>G9-648</b>	<b>G9-649</b>	<b>LM-10020S</b>
Ref.Nr.: 1J0411314AC	Ref.Nr.: 1J0411327A	Ref.Nr.: 357407182F	Ref.Nr.: 1J0199555BD	Ref.Nr.: 357407182	Ref.Nr.: 1J0407181	Ref.Nr.: 1J0422831B
<b>MK-810160</b>						
Ref.Nr.: 3D0 498 201						

**Article Description****Article Nr.****Fitting Position**

<b>GOLF V (1K1)</b>		<b>10/2003 → 02/2009</b>	
Dust Cover Kit, shock absorber	1.4 16V, 1.4 FSI, 1.4 TSI, 1.6, 1.6 FSI, 1.9 TDI, 1.9 TDI 4motion, 2.0 FSI, 2.0 FSI 4motion, 2.0 GTI, 2.0 SDI, 2.0 TDI, 2.0 TDI 16V, 2.0 TDI 16V 4motion, 2.0 TDI 4motion, 3.2 R32 4motion		AK-735095
Dust Cover Kit, shock absorber	1.6, 1.8, 1.8 Hybrid, 1.9 SDI, 2.0	ch.→1K6020000; $\Delta$	AK-735095
Dust Cover Kit, shock absorber	1.6, 1.8, 1.8 Hybrid, 1.9 SDI, 2.0	ST	AK-735095
Dust Cover Kit, shock absorber	1.4 16V, 1.4 FSI, 1.4 TSI, 1.6, 1.6 FSI, 1.9 TDI, 1.9 TDI 4motion, 2.0 FSI, 2.0 FSI 4motion, 2.0 SDI, 2.0 TDI, 2.0 TDI 16V, 2.0 TDI 16V 4motion, 2.0 TDI 4motion	$\Delta$	AK-735172
Dust Cover Kit, shock absorber	1.4 16V, 1.4 FSI, 1.4 TSI, 1.6, 1.6 FSI, 1.9 TDI, 1.9 TDI 4motion, 2.0 FSI, 2.0 FSI 4motion, 2.0 SDI, 2.0 TDI, 2.0 TDI 16V, 2.0 TDI 16V 4motion, 2.0 TDI 4motion		AK-735175
Alternator Freewheel Clutch	1.6, 1.6 MultiFuel, 1.9 TDI, 1.9 TDI 4motion, 2.0, 2.0 FSI, 2.0 FSI 4motion, 2.0 GTI, 2.0 SDI, 2.0 TDI, 2.0 TDI 16V, 2.0 TDI 16V 4motion, 2.0 TDI 4motion, 3.2, 3.2 R32 4motion		F5-1004
Alternator Freewheel Clutch	1.4 TSI		F5-1064
Alternator Freewheel Clutch	3.2, 3.2 R32 4motion		F5-1085
Control Arm-/Trailing Arm Bush	All Models		F8-5633
Belt Pulley, crankshaft	2.0 FSI, 2.0 FSI 4motion		F8-5650
Top Strut Mounting	All Models		F8-6284
Top Strut Mounting	1.4 16V, 1.4 FSI, 1.4 TSI, 1.6, 1.6 FSI, 1.8, 1.8 GTI, 1.8 Hybrid, 1.9 SDI, 1.9 TDI, 2.0, 2.0 FSI, 2.0 GTI, 2.0 SDI, 2.0 TDI, 2.0 TDI 16V, 3.2	ch.→1K-6-020000; $\Delta$	F8-6348
Top Strut Mounting	1.4 16V, 1.4 FSI, 1.4 TSI, 1.6, 1.6 FSI, 1.8, 1.8 GTI, 1.8 Hybrid, 1.9 SDI, 1.9 TDI, 2.0, 2.0 FSI, 2.0 GTI, 2.0 SDI, 2.0 TDI, 2.0 TDI 16V, 3.2	ST	F8-6348
Top Strut Mounting	1.4 16V, 1.4 FSI, 1.4 TSI, 1.6, 1.6 FSI, 1.8, 1.8 GTI, 1.8 Hybrid, 1.9 SDI, 1.9 TDI, 2.0, 2.0 FSI, 2.0 GTI, 2.0 SDI, 2.0 TDI, 2.0 TDI 16V, 3.2	SP	F8-6348
Top Strut Mounting	1.4 16V, 1.4 FSI, 1.4 TSI, 1.6, 1.6 FSI, 1.8, 1.8 GTI, 1.8 Hybrid, 1.9 SDI, 1.9 TDI, 2.0, 2.0 FSI, 2.0 GTI, 2.0 SDI, 2.0 TDI, 2.0 TDI 16V, 3.2	ch.1K-6-020001→; $\Delta$	F8-6349
Top Strut Mounting	1.9 TDI 4motion, 2.0 FSI 4motion, 2.0 TDI 16V 4motion, 2.0 TDI 4motion, 3.2 R32 4motion		F8-6349
Belt Pulley, crankshaft	1.9 TDI, 1.9 TDI 4motion, 2.0 SDI, 2.0 TDI, 2.0 TDI 16V, 2.0 TDI 16V 4motion, 2.0 TDI 4motion	Number of Ribs: 5; Parameter: 6PK	F8-6396
Control Arm-/Trailing Arm Bush	1.4 16V, 1.4 FSI, 1.4 TSI, 1.6, 1.6 FSI, 1.9 TDI, 1.9 TDI 4motion, 2.0, 2.0 FSI, 2.0 FSI 4motion, 2.0 GTI, 2.0 SDI, 2.0 TDI, 2.0 TDI 16V, 2.0 TDI 16V 4motion, 2.0 TDI 4motion, 3.2, 3.2 R32 4motion	Aluminium	F8-6424

<b>AK-735095</b>	<b>AK-735172</b>	<b>AK-735175</b>	<b>F5-1004</b>	<b>F5-1064</b>	<b>F5-1085</b>	<b>F8-5633</b>
Ref.Nr.: 1J0512131B	Ref.Nr.: 1K0511353M	Ref.Nr.: 1K0412303B	Ref.Nr.: 038903119T	Ref.Nr.: 03C903119D	Ref.Nr.: 045903119A	Ref.Nr.: 1K0407182A
<b>F8-5650</b>	<b>F8-6284</b>	<b>F8-6348</b>	<b>F8-6349</b>	<b>F8-6396</b>	<b>F8-6424</b>	<b>F8-6425</b>
Ref.Nr.: 06A105243E	Ref.Nr.: 6N0412249C	Ref.Nr.: 1K0513353G	Ref.Nr.: 1K0513353H	Ref.Nr.: 03G105243	Ref.Nr.: 1K0199232G	Ref.Nr.: 1K0199231J

### Article Description



### Article Nr.

### Fitting Position



<b>GOLF V (1K1)</b>		<b>10/2003 → 02/2009</b>	
Control Arm-/Trailing Arm Bush	1.4 16V, 1.4 FSI, 1.4 TSI, 1.6, 1.6 FSI, 1.9 TDI, 1.9 TDI 4motion, 2.0, 2.0 FSI, 2.0 FSI 4motion, 2.0 GTI, 2.0 SDI, 2.0 TDI, 2.0 TDI 16V, 2.0 TDI 16V 4motion, 2.0 TDI 4motion, 3.2, 3.2 R32 4motion	Aluminium	<b>F8-6425</b>
Control Arm-/Trailing Arm Bush	1.4 16V, 1.4 FSI, 1.4 TSI, 1.6, 1.6 FSI, 1.8, 1.8 GTI, 1.8 Hybrid, 1.9 SDI, 1.9 TDI, 1.9 TDI 4motion, 2.0, 2.0 FSI, 2.0 FSI 4motion, 2.0 GTI, 2.0 SDI, 2.0 TDI, 2.0 TDI 16V, 2.0 TDI 16V 4motion, 2.0 TDI 4motion, 3.2, 3.2 R32 4motion		<b>F8-6463</b> H=64; d=12; D=60
Engine Mounting	2.0 TDI, 2.0 TDI 16V, 2.0 TDI 16V 4motion, 2.0 TDI 4motion		<b>F8-6528</b>
Engine Mounting	1.4 16V, 1.4 FSI, 1.6 FSI		<b>F8-6531</b> H=117.7; L=165; W=149
Anti-Friction Bearing	All Models		<b>F8-6569</b>
Top Strut Mounting	All Models		<b>F8-6570</b>
Engine Mounting	1.6		<b>F8-6988</b>
Engine Mounting	2.0, 2.0 FSI, 2.0 FSI 4motion, 2.0 GTI		<b>F8-6989</b>
Engine Mounting	1.4 TSI		<b>F8-6991</b>
Engine Mounting	1.6 FSI		<b>F8-6991</b>
Engine Mounting	3.2 R32 4motion	BUB	<b>F8-7008</b>
Rubber Buffer, suspension	1.4 16V, 1.4 FSI, 1.4 TSI, 1.6, 1.6 FSI, 1.6 MultiFuel, 1.9 TDI, 1.9 TDI 4motion, 2.0, 2.0 FSI, 2.0 FSI 4motion, 2.0 GTI, 2.0 SDI, 2.0 TDI, 2.0 TDI 16V, 2.0 TDI 16V 4motion, 2.0 TDI 4motion	for OE: 2UA, G02, G07; <b>ST</b>	<b>F8-7131</b> H=70
Rubber Buffer, suspension	2.0 GTI	for OE: 2UA, G02, G07, G11; <b>SP</b>	<b>F8-7131</b> H=70
Rubber Buffer, suspension	2.0 GTI	for OE: G11; <b>SP</b>	<b>F8-7131</b> H=70
Rubber Buffer, suspension	3.2, 3.2 R32 4motion	ch.1K-6-150001→	<b>F8-7131</b> H=70
Protective Cap/Bellow, shock absorber	All Models		<b>F8-7132</b> H=190
Rubber Buffer, suspension	1.4 16V, 1.4 FSI, 1.4 TSI, 1.6, 1.6 FSI, 1.6 MultiFuel, 1.8, 1.8 Hybrid, 1.9 SDI, 1.9 TDI, 2.0, 2.0 FSI, 2.0 SDI, 2.0 TDI, 2.0 TDI 16V, 3.2	for OE: 1JA; <b>ST</b>	<b>F8-7576</b> H=133
Rubber Buffer, suspension	1.4 16V, 1.4 FSI, 1.4 TSI, 1.6, 1.6 FSI, 1.8, 1.8 Hybrid, 1.9 SDI, 1.9 TDI, 2.0, 2.0 FSI, 2.0 SDI, 2.0 TDI, 2.0 TDI 16V	ch.→1K-6-020500; for OE: 1JB; <b>Δ</b>	<b>F8-7576</b> H=133
Rubber Buffer, suspension	1.8 GTI, 2.0 GTI	for OE: 1JH	<b>F8-7576</b> H=133
Rubber Buffer, suspension	1.4 16V, 1.4 FSI, 1.4 TSI, 1.6, 1.6 FSI, 1.8, 1.8 Hybrid, 1.9 SDI, 1.9 TDI, 2.0, 2.0 FSI, 2.0 SDI, 2.0 TDI, 2.0 TDI 16V	ch.1K-6-020501→; <b>Δ</b>	<b>F8-7600</b> H=133
Rubber Buffer, suspension	1.4 TSI, 1.6 MultiFuel	<b>Δ</b>	<b>F8-7600</b> H=133
Rubber Buffer, suspension	1.9 TDI 4motion, 2.0 FSI 4motion, 2.0 TDI 16V 4motion, 2.0 TDI 4motion	<b>Δ, ST</b>	<b>F8-7600</b> H=133

<b>F8-6425</b>	<b>F8-6463</b>	<b>F8-6528</b>	<b>F8-6531</b>	<b>F8-6569</b>	<b>F8-6570</b>	<b>F8-6988</b>
Ref.Nr.: 1K0199231J	Ref.Nr.: 1K0505541B	Ref.Nr.: 1K0 199 262 AT	Ref.Nr.: 1K0199262T	Ref.Nr.: 6N0412249C	Ref.Nr.: 1K0412331C	Ref.Nr.: 1K0199262AL
<b>F8-6989</b>	<b>F8-6991</b>	<b>F8-7008</b>	<b>F8-7131</b>	<b>F8-7132</b>	<b>F8-7576</b>	<b>F8-7600</b>
Ref.Nr.: 1K0199262AM	Ref.Nr.: 1K0199262AK	Ref.Nr.: 1K0199262Q	Ref.Nr.: 1K0412303B	Ref.Nr.: 6N0413175A	Ref.Nr.: 1K0 511 353 M	Ref.Nr.: 1K0 511 353 P
<b>F8-7601</b>						
Ref.Nr.: 1K0511353N						



**Article Description****Article Nr.****Fitting Position**

<b>GOLF V (1K1)</b>			<b>10/2003 → 02/2009</b>		
Rubber Buffer, suspension	1.4 16V, 1.4 FSI, 1.4 TSI, 1.6, 1.6 FSI, 1.6 MultiFuel, 1.8, 1.8 Hybrid, 1.9 SDI, 1.9 TDI, 2.0, 2.0 FSI, 2.0 SDI, 2.0 TDI, 2.0 TDI 16V	for OE: 1JC, 1JK; Shape Round; <b>SP</b>	<b>F8-7601</b>		H=118
Rubber Buffer, suspension	1.8 GTI, 2.0 GTI	for OE: 1JE; Shape Round	<b>F8-7601</b>		H=118
Protective Cap/Bellow, shock absorber	1.4 16V, 1.4 FSI, 1.4 TSI, 1.6, 1.6 FSI, 1.6 MultiFuel, 1.8, 1.8 GTI, 1.8 Hybrid, 1.9 SDI, 1.9 TDI, 2.0, 2.0 FSI, 2.0 GTI, 2.0 SDI, 2.0 TDI, 2.0 TDI 16V, 3.2	for OE: 1JA, 1JC, 1JK; <b>SP</b> , <b>ST</b>	<b>F8-7640</b>		H=176
Rubber Buffer, suspension	1.4 16V, 1.4 FSI, 1.4 TSI, 1.6, 1.6 FSI, 1.6 MultiFuel, 1.9 TDI, 1.9 TDI 4motion, 2.0, 2.0 FSI, 2.0 FSI 4motion, 2.0 GTI, 2.0 SDI, 2.0 TDI, 2.0 TDI 16V, 2.0 TDI 16V 4motion, 2.0 TDI 4motion, 3.2, 3.2 R32 4motion	for OE: 2UC, G07; <b>SP</b>	<b>F8-7697</b>		H=55
Rubber Buffer, suspension	2.0 GTI	for OE: G08; <b>SP</b>	<b>F8-7697</b>		H=55
Rubber Buffer, suspension	1.4 16V, 1.4 FSI, 1.4 TSI, 1.6, 1.6 FSI, 1.6 MultiFuel, 1.9 TDI, 1.9 TDI 4motion, 2.0, 2.0 FSI, 2.0 FSI 4motion, 2.0 GTI, 2.0 SDI, 2.0 TDI, 2.0 TDI 16V, 2.0 TDI 16V 4motion, 2.0 TDI 4motion, 3.2, 3.2 R32 4motion	for OE: 2UB, G02; <b>Δ</b>	<b>F8-7703</b>		H=90; d=25
Rubber Buffer, suspension	1.4 16V, 1.4 FSI, 1.4 TSI, 1.6, 1.6 FSI, 1.6 MultiFuel, 1.9 TDI, 2.0, 2.0 FSI, 2.0 GTI, 2.0 SDI, 2.0 TDI, 2.0 TDI 16V, 3.2	for OE: 2UC, G02; <b>SP</b>	<b>F8-7809</b>		H=55
Rubber Buffer, suspension	1.9 TDI 4motion, 2.0 FSI 4motion, 2.0 TDI 16V 4motion, 2.0 TDI 4motion, 3.2 R32 4motion	for OE: 2UC, G02	<b>F8-7809</b>		H=55
Rubber Buffer, suspension	All Models	for OE: 2UB, G07, G57; <b>Δ</b>	<b>F8-7834</b>		H=90
Belt Pulley, crankshaft	2.0 GTI	Number of Ribs: 5; Parameter: 6PK	<b>F8-7880</b>		D=143
Rubber Buffer, suspension	1.9 TDI 4motion, 2.0 FSI 4motion, 2.0 TDI 16V 4motion, 2.0 TDI 4motion	for OE: 1JC, 1JK; Shape Oval; <b>SP</b>	<b>F8-7897</b>		H=118
Rubber Buffer, suspension	3.2 R32 4motion	Shape Oval	<b>F8-7897</b>		H=118
Control Arm-/Trailing Arm Bush	All Models		<b>F8-7902</b>		H=60; d=12; D=42
Control Arm-/Trailing Arm Bush	All Models		<b>F8-7907</b>		H=45; d=14; D=38
Control Arm-/Trailing Arm Bush	All Models		<b>F8-7908</b>		H=45; d=12; D=38
Control Arm-/Trailing Arm Bush	All Models		<b>F8-7909</b>		
Stabiliser Mounting	1.4 16V, 1.4 FSI, 1.4 TSI, 1.6, 1.6 FSI, 1.9 TDI, 1.9 TDI 4motion, 2.0 FSI, 2.0 FSI 4motion, 2.0 GTI, 2.0 SDI, 2.0 TDI, 2.0 TDI 16V, 2.0 TDI 16V 4motion, 2.0 TDI 4motion, 3.2 R32 4motion		<b>F8-7923</b>		d=20,7
Stabiliser Mounting	1.4 16V, 1.4 FSI, 1.4 TSI, 1.6, 1.6 FSI, 1.9 TDI, 1.9 TDI 4motion, 2.0 FSI, 2.0 FSI 4motion, 2.0 GTI, 2.0 SDI, 2.0 TDI, 2.0 TDI 16V, 2.0 TDI 16V 4motion, 3.2 R32 4motion		<b>F8-7930</b>		d=18,5
Engine Mounting	1.9 TDI, 1.9 TDI 4motion, 2.0 SDI		<b>F8-7958</b>		

<b>F8-7601</b>	<b>F8-7640</b>	<b>F8-7697</b>	<b>F8-7703</b>	<b>F8-7809</b>	<b>F8-7834</b>	<b>F8-7880</b>
Ref.Nr.: 1K0511353N	Ref.Nr.: 1K0513425A	Ref.Nr.: 1K0412303F	Ref.Nr.: 1K0412303G	Ref.Nr.: 1K0412303E	Ref.Nr.: 1K0412303H	Ref.Nr.: 06H105243F
<b>F8-7897</b>	<b>F8-7902</b>	<b>F8-7907</b>	<b>F8-7908</b>	<b>F8-7909</b>	<b>F8-7923</b>	<b>F8-7930</b>
Ref.Nr.: 1K0511353F	Ref.Nr.: 1K0505171C	Ref.Nr.: 1K0505203A	Ref.Nr.: 1K0505279A	Ref.Nr.: 1K0505553 A	Ref.Nr.: 1K0511327AR	Ref.Nr.: 1K0511327AP
<b>F8-7958</b>	<b>F8-7959</b>					
Ref.Nr.: 1K0199262AS	Ref.Nr.: 1K0199262CG					

Article Description



Article Nr.

Fitting Position



**GOLF V (1K1)** 10/2003 → 02/2009

Engine Mounting	1.4 TSI		<b>F8-7959</b>	⊕	
Engine Mounting	1.4 TSI	ch.→1K-9-200000; 05/2007 →	<b>F8-7959</b>	⊕	
Engine Mounting	1.4 16V, 1.4 FSI, 1.4 TSI, 1.6, 1.6 FSI		<b>F8-7960</b>	⊕	
Engine Mounting	1.6, 1.6 FSI, 2.0 FSI	6-speed	<b>F8-7961</b>	⊕	
Engine Mounting	1.9 TDI	6-speed	<b>F8-7961</b>	⊕	
Engine Mounting	1.9 TDI	BLS	<b>F8-7961</b>	⊕	
Engine Mounting	2.0 FSI 4motion	BLX;  6-speed	<b>F8-7961</b>	⊕	
Engine Mounting	1.9 TDI, 2.0 TDI, 2.0 TDI 16V	Transmission Type: DSG	<b>F8-7962</b>	⊕	
Engine Mounting	2.0 GTI	6-speed	<b>F8-7962</b>	⊕	
Engine Mounting	1.4 16V, 1.4 FSI, 1.4 TSI, 2.0 SDI		<b>F8-7965</b>		
Engine Mounting	1.6, 1.6 FSI		<b>F8-7965</b>		
Engine Mounting	1.6	ch.→1K-9-200000;  6-speed	<b>F8-7966</b>		
Engine Mounting	1.6 FSI	ch.→1K-9-200000;  BLF;  6-speed	<b>F8-7966</b>		
Engine Mounting	1.9 TDI, 1.9 TDI 4motion, 2.0 FSI, 2.0 FSI 4motion, 2.0 GTI, 2.0 TDI, 2.0 TDI 16V, 2.0 TDI 16V 4motion, 2.0 TDI 4motion		<b>F8-7966</b>		
Engine Mounting	1.4 16V, 1.4 FSI, 1.4 TSI, 1.6, 1.6 FSI, 1.6 MultiFuel, 1.9 TDI, 2.0 FSI 4motion, 2.0 GTI, 2.0 SDI, 2.0 TDI, 2.0 TDI 16V		<b>F8-7982</b>	↑	
Engine Mounting	1.9 TDI 4motion, 2.0 TDI 16V 4motion, 2.0 TDI 4motion	ch.→1K-8-120000	<b>F8-7982</b>	↑	
Engine Mounting	2.0 FSI	AXW, BLR, BLX, BLY, BVX, BVZ	<b>F8-7982</b>	↑	
Engine Mounting	3.2	ch.→1K-8-400000	<b>F8-7982</b>	↑	
Engine Mounting	3.2 R32 4motion	ch.→1K-8-400000;  BUB	<b>F8-7982</b>	↑	
Engine Mounting	1.9 TDI 4motion, 2.0 TDI, 2.0 TDI 16V, 2.0 TDI 16V 4motion, 2.0 TDI 4motion	6-speed	<b>F8-8152</b>	⊕	
Engine Mounting	2.0 TDI	AVZ;  6-speed	<b>F8-8152</b>	⊕	

**GOLF V Variant (1K5)** 06/2007 → 07/2009

Alternator Freewheel Clutch	1.6, 1.6 MultiFuel, 1.9 TDI, 1.9 TDI 4motion, 2.0, 2.0 TDI, 2.0 TDI 16V, 2.0 TDI 4motion		<b>F5-1004</b>		
Alternator Freewheel Clutch	2.0		<b>F5-1044</b>		
Alternator Freewheel Clutch	1.4 TSI		<b>F5-1064</b>		
Control Arm-/Trailing Arm Bush	All Models		<b>F8-5633</b>		
Top Strut Mounting	All Models		<b>F8-6284</b>		
Top Strut Mounting	1.4, 1.4 TSI, 1.6, 1.9 TDI, 2.0, 2.0 TDI, 2.0 TDI 16V		<b>F8-6349</b>		
Top Strut Mounting	1.9 TDI 4motion, 2.0 TDI 4motion		<b>F8-6349</b>		
Belt Pulley, crankshaft	1.9 TDI, 2.0 TDI, 2.0 TDI 16V	Number of Ribs: 5; Parameter: 6PK	<b>F8-6396</b>		H=41.6; d=30; Mounting points diam.[mm]=7, 8.6; D=139.7

<b>F5-1004</b>	<b>F5-1044</b>	<b>F5-1064</b>	<b>F8-5633</b>	<b>F8-6284</b>	<b>F8-6349</b>	<b>F8-6396</b>
Ref.Nr.: 038903119T	Ref.Nr.: 06B903119B	Ref.Nr.: 03C903119D	Ref.Nr.: 1K0407182A	Ref.Nr.: 6N0412249C	Ref.Nr.: 1K0513353H	Ref.Nr.: 03G105243
<b>F8-6424</b>	<b>F8-7959</b>	<b>F8-7960</b>	<b>F8-7961</b>	<b>F8-7962</b>	<b>F8-7965</b>	<b>F8-7966</b>
Ref.Nr.: 1K0199232G	Ref.Nr.: 1K0199262CG	Ref.Nr.: 1K0199555L	Ref.Nr.: 1K0199555N	Ref.Nr.: 1K0199555Q	Ref.Nr.: 1K0199855BA	Ref.Nr.: 1K0199855BB
<b>F8-7982</b>	<b>F8-8152</b>					
Ref.Nr.: 1K0199868Q	Ref.Nr.: 1K0199555T					

**Article Description****Article Nr.****Fitting Position**

<b>GOLF V Variant (1K5)</b>			<b>06/2007 → 07/2009</b>		
Control Arm-/Trailing Arm Bush	1.4, 1.4 TSI, 1.6, 1.9 TDI, 1.9 TDI 4motion, 2.0, 2.0 TDI, 2.0 TDI 16V, 2.0 TDI 4motion	Aluminium	<b>F8-6424</b>		
Control Arm-/Trailing Arm Bush	1.4, 1.4 TSI, 1.6, 1.9 TDI, 1.9 TDI 4motion, 2.0, 2.0 TDI, 2.0 TDI 16V, 2.0 TDI 4motion	Aluminium	<b>F8-6425</b>		
Control Arm-/Trailing Arm Bush	1.4, 1.4 TSI, 1.6, 1.9 TDI, 1.9 TDI 4motion, 2.0, 2.0 TDI, 2.0 TDI 16V		<b>F8-6463</b>		H=64; d=12; D=60
Engine Mounting	2.0 TDI 16V	BKD	<b>F8-6528</b>		
Engine Mounting	2.0 TDI, 2.0 TDI 4motion		<b>F8-6528</b>		
Engine Mounting	1.4		<b>F8-6531</b>		H=117.7; L=165; W=149
Anti-Friction Bearing	All Models		<b>F8-6569</b>		
Top Strut Mounting	All Models		<b>F8-6570</b>		
Engine Mounting	2.0	BWA	<b>F8-6989</b>		
Protective Cap/Bellow, shock absorber	All Models		<b>F8-7132</b>		H=190
Rubber Buffer, suspension	1.9 TDI 4motion, 2.0 TDI 4motion	for OE: 1JA;	<b>F8-7140</b>		H=133
Rubber Buffer, suspension	1.4, 1.4 TSI, 1.6, 1.9 TDI, 2.0, 2.0 TDI, 2.0 TDI 16V	for OE: 1JA, 4P1;	<b>F8-7576</b>		H=133
Rubber Buffer, suspension	1.4, 1.4 TSI, 1.6, 1.6 MultiFuel, 1.9 TDI, 2.0, 2.0 TDI, 2.0 TDI 16V		<b>F8-7600</b>		H=133
Rubber Buffer, suspension	1.9 TDI 4motion, 2.0 TDI 4motion		<b>F8-7600</b>		H=133
Rubber Buffer, suspension	1.4, 1.4 TSI, 1.6, 1.6 MultiFuel, 1.9 TDI, 2.0, 2.0 TDI, 2.0 TDI 16V	for OE: 1JC, 1JK; Shape Round;	<b>F8-7601</b>		H=118
Top Strut Mounting	1.9 TDI 4motion, 2.0 TDI 4motion		<b>F8-7603</b>		
Protective Cap/Bellow, shock absorber	1.4, 1.4 TSI, 1.6, 1.6 MultiFuel, 1.9 TDI, 2.0, 2.0 TDI, 2.0 TDI 16V	for OE: 1JA, 1JC, 1JK;	<b>F8-7640</b>		H=176
Rubber Buffer, suspension	All Models	for OE: 2UC, G57, G68;	<b>F8-7697</b>		H=55
Rubber Buffer, suspension	All Models	for OE: 2UB, G02, G56;	<b>F8-7703</b>		H=90; d=25
Rubber Buffer, suspension	1.9 TDI 4motion, 2.0 TDI 4motion	for OE: 1JC, 1JK;	<b>F8-7714</b>		H=118
Rubber Buffer, suspension	All Models	for OE: 2UC, G56	<b>F8-7809</b>		H=55
Rubber Buffer, suspension	All Models	for OE: 2UB, G07, G57;	<b>F8-7834</b>		H=90
Belt Pulley, crankshaft	2.0	Number of Ribs: 5; Parameter: 6PK	<b>F8-7880</b>		D=143
Rubber Buffer, suspension	1.4, 1.4 TSI, 1.6, 1.6 MultiFuel, 1.9 TDI, 2.0, 2.0 TDI, 2.0 TDI 16V	for OE: 1JC+4P3; Shape Oval;	<b>F8-7897</b>		H=118
Control Arm-/Trailing Arm Bush	All Models		<b>F8-7902</b>		H=60; d=12; D=42
Control Arm-/Trailing Arm Bush	All Models		<b>F8-7907</b>		H=45; d=14; D=38
Control Arm-/Trailing Arm Bush	All Models		<b>F8-7908</b>		H=45; d=12; D=38
Control Arm-/Trailing Arm Bush	All Models		<b>F8-7909</b>		

<b>F8-6424</b>	<b>F8-6425</b>	<b>F8-6463</b>	<b>F8-6528</b>	<b>F8-6531</b>	<b>F8-6569</b>	<b>F8-6570</b>
Ref.Nr.: 1K0199232G	Ref.Nr.: 1K0199231J	Ref.Nr.: 1K0505541B	Ref.Nr.: 1K0 199 262 AT	Ref.Nr.: 1K0199262T	Ref.Nr.: 6N0412249C	Ref.Nr.: 1K0412331C
<b>F8-6989</b>	<b>F8-7132</b>	<b>F8-7140</b>	<b>F8-7576</b>	<b>F8-7600</b>	<b>F8-7601</b>	<b>F8-7603</b>
Ref.Nr.: 1K0199262AM	Ref.Nr.: 6N0413175A	Ref.Nr.: 3C0511359	Ref.Nr.: 1K0 511 353 M	Ref.Nr.: 1K0 511 353 P	Ref.Nr.: 1K0511353N	Ref.Nr.: 3C0513353
<b>F8-7640</b>	<b>F8-7697</b>	<b>F8-7703</b>	<b>F8-7714</b>	<b>F8-7809</b>	<b>F8-7834</b>	<b>F8-7880</b>
Ref.Nr.: 1K0513425A	Ref.Nr.: 1K0412303F	Ref.Nr.: 1K0412303G	Ref.Nr.: 3C0511359B	Ref.Nr.: 1K0412303E	Ref.Nr.: 1K0412303H	Ref.Nr.: 06H105243F

Article Description



Article Nr.

Fitting Position



**GOLF V Variant (1K5)** 06/2007 → 07/2009

Engine Mounting	1.4 TSI		F8-7959	↻	
Engine Mounting	1.4 TSI	ch. 1K-8-300 001→	F8-7959	↻	
Engine Mounting	1.4, 1.4 TSI, 1.6		F8-7960	↻	
Engine Mounting	1.6	6-speed	F8-7961	↻	
Engine Mounting	1.9 TDI	BLS, BXE;  6-speed	F8-7961	↻	
Engine Mounting	1.9 TDI	BLS, BXE;  7-speed	F8-7961	↻	
Engine Mounting	2.0 TDI 16V	BKD;  7-speed	F8-7961	↻	
Engine Mounting	2.0 TDI, 2.0 TDI 4motion	7-speed	F8-7961	↻	
Engine Mounting	1.9 TDI, 2.0 TDI, 2.0 TDI 16V	Transmission Type: DSG	F8-7962	↻	
Engine Mounting	1.9 TDI, 2.0 TDI, 2.0 TDI 16V	6-speed	F8-7962	↻	
Engine Mounting	2.0	6-speed	F8-7962	↻	
Engine Mounting	1.4, 1.4 TSI, 1.6		F8-7965		
Engine Mounting	1.4, 1.4 TSI, 1.6 MultiFuel, 1.9 TDI, 2.0 TDI, 2.0 TDI 16V, 2.0 TDI 4motion		F8-7982	↑	
Engine Mounting	1.6	BSE, BSF, CCSA	F8-7982	↑	
Engine Mounting	1.9 TDI 4motion		F8-7982	↑	
Engine Mounting	2.0	BWA, CCTA	F8-7982	↑	
Engine Mounting	1.9 TDI 4motion, 2.0 TDI, 2.0 TDI 16V	6-speed	F8-8152	↻	
Engine Mounting	2.0 TDI 16V	CBDA, CBDB;  6-speed	F8-8152	↻	

**GOLF PLUS (5M1, 521)** 01/2005 → 12/2013

Dust Cover Kit, shock absorber	1.2 TSI, 1.4 16V, 1.4 FSI, 1.4 TSI, 1.6, 1.6 BiFuel, 1.6 FSI, 1.6 MultiFuel, 1.6 TDI, 1.9 TDI, 2.0 FSI, 2.0 TDI, 2.0 TDI 16V	ch.→1K6505000;	AK-735095	↻ ↻	
Dust Cover Kit, shock absorber	1.2 TSI, 1.4 16V, 1.4 FSI, 1.4 TSI, 1.6, 1.6 BiFuel, 1.6 FSI, 1.6 MultiFuel, 1.6 TDI, 1.9 TDI, 2.0 FSI, 2.0 TDI, 2.0 TDI 16V		AK-735095	↻ ↻	
Dust Cover Kit, shock absorber	1.4 16V, 1.4 FSI, 1.4 TSI, 1.6, 1.6 FSI, 1.9 TDI, 2.0 FSI, 2.0 TDI, 2.0 TDI 16V		AK-735172	↻ ↻	
Dust Cover Kit, shock absorber	1.4 16V, 1.4 FSI, 1.4 TSI, 1.6, 1.6 FSI, 1.9 TDI, 2.0 FSI, 2.0 TDI, 2.0 TDI 16V		AK-735175	↻ ↻	
Alternator Freewheel Clutch	1.6, 1.6 BiFuel, 1.6 MultiFuel, 1.6 TDI, 1.9 TDI, 2.0 FSI, 2.0 TDI, 2.0 TDI 16V		F5-1004		
Alternator Freewheel Clutch	1.2 TSI, 1.4 TSI		F5-1064		
Control Arm-/Trailing Arm Bush	All Models		F8-5633	↻ ↻	
Belt Pulley, crankshaft	2.0 FSI		F8-5650		
Rubber Buffer, suspension	1.2 TSI	for OE: G12;	F8-6041	↻ ↻	H=53

<b>AK-735095</b>	<b>AK-735172</b>	<b>AK-735175</b>	<b>F5-1004</b>	<b>F5-1064</b>	<b>F8-5633</b>	<b>F8-5650</b>
Ref.Nr.: 1J0512131B	Ref.Nr.: 1K0511353M	Ref.Nr.: 1K0412303B	Ref.Nr.: 038903119T	Ref.Nr.: 03C903119D	Ref.Nr.: 1K0407182A	Ref.Nr.: 06A105243E
<b>F8-6041</b>	<b>F8-6284</b>	<b>F8-7959</b>	<b>F8-7960</b>	<b>F8-7961</b>	<b>F8-7962</b>	<b>F8-7965</b>
Ref.Nr.: 1J0412303	Ref.Nr.: 6N0412249C	Ref.Nr.: 1K0199262CG	Ref.Nr.: 1K0199555L	Ref.Nr.: 1K0199555N	Ref.Nr.: 1K0199555Q	Ref.Nr.: 1K0199855BA
<b>F8-7982</b>	<b>F8-8152</b>					
Ref.Nr.: 1K0199868Q	Ref.Nr.: 1K0199555T					

**Article Description****Article Nr.****Fitting Position****GOLF PLUS (5M1, 521)****01/2005 → 12/2013**

Top Strut Mounting	1.2 TSI, 1.4 16V, 1.4 FSI, 1.4 TSI, 1.6, 1.6 BiFuel, 1.6 FSI, 1.6 MultiFuel, 1.6 TDI, 1.9 TDI, 2.0 FSI, 2.0 TDI, 2.0 TDI 16V		<b>F8-6284</b>		
Top Strut Mounting	1.2 TSI, 1.4 16V, 1.4 FSI, 1.4 TSI, 1.6, 1.6 BiFuel, 1.6 FSI, 1.6 MultiFuel, 1.6 TDI, 1.9 TDI, 2.0 FSI, 2.0 TDI, 2.0 TDI 16V		<b>F8-6348</b>		
Top Strut Mounting	1.2 TSI, 1.4 16V, 1.4 FSI, 1.4 TSI, 1.6, 1.6 BiFuel, 1.6 FSI, 1.6 MultiFuel, 1.6 TDI, 1.9 TDI, 2.0 FSI, 2.0 TDI, 2.0 TDI 16V		<b>F8-6348</b>		
Top Strut Mounting	1.4 16V, 1.4 FSI, 1.4 TSI, 1.6, 1.6 FSI, 1.9 TDI, 2.0 FSI, 2.0 TDI, 2.0 TDI 16V	ch.→1K-6-505000;	<b>F8-6348</b>		
Top Strut Mounting	1.2 TSI, 1.6 BiFuel, 1.6 MultiFuel, 1.6 TDI, 2.0 TDI	Shape Oval;	<b>F8-6349</b>		
Top Strut Mounting	1.4 16V, 1.4 FSI, 1.4 TSI, 1.6, 1.6 FSI, 1.9 TDI, 2.0 FSI, 2.0 TDI, 2.0 TDI 16V	ch.1K-6-505001→; Shape Oval;	<b>F8-6349</b>		
Top Strut Mounting	1.4 TSI	ch.1K-6-020001→; Shape Oval;	<b>F8-6349</b>		
Belt Pulley, crankshaft	1.9 TDI, 2.0 TDI, 2.0 TDI 16V	Number of Ribs: 5; Parameter: 6PK	<b>F8-6396</b>		H=41.6; d=30; Mounting points diam.[mm]=7, 8.6; D=139.7
Control Arm-/Trailing Arm Bush	1.2 TSI, 1.4 16V, 1.4 FSI, 1.4 TSI, 1.6, 1.6 FSI, 1.9 TDI, 2.0 FSI, 2.0 TDI, 2.0 TDI 16V	Aluminium	<b>F8-6424</b>		
Control Arm-/Trailing Arm Bush	1.2 TSI, 1.4 16V, 1.4 FSI, 1.4 TSI, 1.6, 1.6 FSI, 1.9 TDI, 2.0 FSI, 2.0 TDI, 2.0 TDI 16V	Aluminium	<b>F8-6425</b>		
Control Arm-/Trailing Arm Bush	1.4 16V, 1.4 FSI, 1.4 TSI, 1.6, 1.6 FSI, 1.6 MultiFuel, 1.6 TDI, 1.8, 1.8 Hybrid, 1.9 SDI, 1.9 TDI, 2.0 FSI, 2.0 TDI, 2.0 TDI 16V		<b>F8-6463</b>		H=64; d=12; D=60
Engine Mounting	2.0 TDI		<b>F8-6528</b>		
Engine Mounting	2.0 TDI 16V	BKD	<b>F8-6528</b>		
Engine Mounting	1.4 16V, 1.4 FSI, 1.6 FSI		<b>F8-6531</b>		H=117.7; L=165; W=149
Anti-Friction Bearing	1.2 TSI, 1.4 16V, 1.4 FSI, 1.4 TSI, 1.6, 1.6 BiFuel, 1.6 FSI, 1.6 MultiFuel, 1.6 TDI, 1.9 TDI, 2.0 FSI, 2.0 TDI, 2.0 TDI 16V		<b>F8-6569</b>		
Top Strut Mounting	1.2 TSI, 1.4 16V, 1.4 FSI, 1.4 TSI, 1.6, 1.6 BiFuel, 1.6 FSI, 1.6 MultiFuel, 1.6 TDI, 1.9 TDI, 2.0 FSI, 2.0 TDI, 2.0 TDI 16V		<b>F8-6570</b>		
Belt Pulley, crankshaft	1.6 TDI	Number of Ribs: 5; Parameter: 6PK	<b>F8-6572</b>		
Belt Pulley, crankshaft	2.0 TDI	CFHB; Number of Ribs: 5; Parameter: 6PK	<b>F8-6572</b>		
Belt Pulley, crankshaft	2.0 TDI	CLCA; Number of Ribs: 5; Parameter: 6PK	<b>F8-6572</b>		
Engine Mounting	1.6		<b>F8-6988</b>		
Engine Mounting	2.0 FSI		<b>F8-6989</b>		
Rubber Buffer, suspension	1.2 TSI, 1.4 16V, 1.4 TSI, 1.6 BiFuel, 1.6 MultiFuel, 1.6 TDI, 2.0 TDI	for OE: 2UA, G02, G07, G72, G73;	<b>F8-7131</b>		H=70
Rubber Buffer, suspension	1.4 16V, 1.4 FSI, 1.4 TSI, 1.6, 1.6 FSI, 1.9 TDI, 2.0 FSI, 2.0 TDI, 2.0 TDI 16V	for OE: 2UA, G02, G07;	<b>F8-7131</b>		H=70

<b>F8-6284</b>	<b>F8-6348</b>	<b>F8-6349</b>	<b>F8-6396</b>	<b>F8-6424</b>	<b>F8-6425</b>	<b>F8-6463</b>
Ref.Nr.: 6N0412249C	Ref.Nr.: 1K0513353G	Ref.Nr.: 1K0513353H	Ref.Nr.: 03G105243	Ref.Nr.: 1K0199232G	Ref.Nr.: 1K0199231J	Ref.Nr.: 1K0505541B
<b>F8-6528</b>	<b>F8-6531</b>	<b>F8-6569</b>	<b>F8-6570</b>	<b>F8-6572</b>	<b>F8-6988</b>	<b>F8-6989</b>
Ref.Nr.: 1K0 199 262 AT	Ref.Nr.: 1K0199262T	Ref.Nr.: 6N0412249C	Ref.Nr.: 1K0412331C	Ref.Nr.: 038105243L	Ref.Nr.: 1K0199262AL	Ref.Nr.: 1K0199262AM
<b>F8-7131</b>	<b>F8-7132</b>					
Ref.Nr.: 1K0412303B	Ref.Nr.: 6N0413175A					

**Article Description**

**Article Nr.**
**Fitting Position**

<b>GOLF PLUS (5M1, 521)</b>			<b>01/2005 → 12/2013</b>		
Protective Cap/Bellow, shock absorber	All Models		<b>F8-7132</b>		H=190
Rubber Buffer, suspension	1.2 TSI, 1.4 16V, 1.4 FSI, 1.6 BiFuel	for OE: 1JB;	<b>F8-7140</b>		H=133
Rubber Buffer, suspension	1.4 16V, 1.4 TSI, 1.6, 1.6 MultiFuel, 1.6 TDI, 1.8, 1.8 Hybrid, 1.9 SDI, 2.0 TDI, 2.0 TDI 16V	05/2009 →; for OE: 1JB;	<b>F8-7140</b>		H=133
Rubber Buffer, suspension	1.2 TSI, 1.4 16V, 1.4 FSI, 1.4 TSI, 1.6, 1.6 BiFuel, 1.6 FSI, 1.6 MultiFuel, 1.6 TDI, 1.8, 1.8 Hybrid, 1.9 SDI, 1.9 TDI, 2.0 FSI, 2.0 TDI, 2.0 TDI 16V	for OE: 1JA;	<b>F8-7576</b>		H=133
Rubber Buffer, suspension	1.4 16V, 1.4 FSI, 1.4 TSI, 1.6, 1.6 FSI, 1.8, 1.8 Hybrid, 1.9 SDI, 1.9 TDI, 2.0 FSI, 2.0 TDI, 2.0 TDI 16V	ch.→1K-6-505000;	<b>F8-7576</b>		H=133
Rubber Buffer, suspension	1.4 16V, 1.4 FSI, 1.4 TSI, 1.6, 1.6 FSI, 1.8, 1.8 Hybrid, 1.9 SDI, 1.9 TDI, 2.0 FSI, 2.0 TDI, 2.0 TDI 16V	ch.1K-6-505001→;	<b>F8-7600</b>		H=133
Rubber Buffer, suspension	1.4 TSI, 1.6 TDI, 2.0 TDI		<b>F8-7600</b>		H=133
Rubber Buffer, suspension	All Models	for OE: 1JC, 1JK; Shape Round;	<b>F8-7601</b>		H=118
Top Strut Mounting	1.2 TSI, 1.6 BiFuel, 1.6 MultiFuel, 1.6 TDI, 2.0 TDI	Shape Round;	<b>F8-7603</b>		
Top Strut Mounting	1.4 16V, 1.4 FSI, 1.4 TSI, 1.6, 1.6 FSI, 1.9 TDI, 2.0 FSI, 2.0 TDI, 2.0 TDI 16V	ch.1K-6-505001→; Shape Round;	<b>F8-7603</b>		
Top Strut Mounting	1.4 TSI	ch.1K-6-020001→; Shape Round;	<b>F8-7603</b>		
Protective Cap/Bellow, shock absorber	1.2 TSI, 1.4 16V, 1.4 FSI, 1.4 TSI, 1.6, 1.6 BiFuel, 1.6 FSI, 1.6 MultiFuel, 1.6 TDI, 1.8, 1.8 Hybrid, 1.9 SDI, 1.9 TDI, 2.0 FSI, 2.0 TDI, 2.0 TDI 16V	ch.→1K-6-505000; for OE: 1JB;	<b>F8-7640</b>		H=176
Protective Cap/Bellow, shock absorber	1.2 TSI, 1.4 16V, 1.4 FSI, 1.4 TSI, 1.6, 1.6 BiFuel, 1.6 FSI, 1.6 MultiFuel, 1.6 TDI, 1.8, 1.8 Hybrid, 1.9 SDI, 1.9 TDI, 2.0 FSI, 2.0 TDI, 2.0 TDI 16V	for OE: 1JA, 1JC, 1JK; ,	<b>F8-7640</b>		H=176
Rubber Buffer, suspension	1.2 TSI, 1.4 16V, 1.4 FSI, 1.4 TSI, 1.6, 1.6 BiFuel, 1.6 FSI, 1.6 MultiFuel, 1.6 TDI, 1.9 TDI, 2.0 FSI, 2.0 TDI, 2.0 TDI 16V	for OE: 2UC, G07;	<b>F8-7697</b>		H=55
Rubber Buffer, suspension	1.2 TSI, 1.4 16V, 1.4 FSI, 1.4 TSI, 1.6, 1.6 BiFuel, 1.6 FSI, 1.6 MultiFuel, 1.6 TDI, 1.9 TDI, 2.0 FSI, 2.0 TDI, 2.0 TDI 16V	for OE: 2UB, G02;	<b>F8-7703</b>		H=90; d=25
Rubber Buffer, suspension	1.2 TSI, 1.4 16V, 1.4 FSI, 1.4 TSI, 1.6, 1.6 BiFuel, 1.6 FSI, 1.6 MultiFuel, 1.6 TDI, 1.9 TDI, 2.0 FSI, 2.0 TDI, 2.0 TDI 16V	for OE: 2UC, G02	<b>F8-7809</b>		H=55
Rubber Buffer, suspension	All Models	for OE: 2UB, G07;	<b>F8-7834</b>		H=90
Control Arm-/Trailing Arm Bush	All Models		<b>F8-7902</b>		H=60; d=12; D=42
Control Arm-/Trailing Arm Bush	All Models		<b>F8-7907</b>		H=45; d=14; D=38
Control Arm-/Trailing Arm Bush	All Models		<b>F8-7908</b>		H=45; d=12; D=38
Control Arm-/Trailing Arm Bush	All Models		<b>F8-7909</b>		
Stabiliser Mounting	1.4 16V, 1.4 FSI, 1.4 TSI, 1.6, 1.6 FSI, 1.9 TDI, 2.0 FSI, 2.0 TDI, 2.0 TDI 16V		<b>F8-7923</b>		d=20,7



**Article Description****Article Nr.****Fitting Position**

<b>GOLF PLUS (5M1, 521)</b>			<b>01/2005 → 12/2013</b>		
Stabiliser Mounting	1.4 16V, 1.4 TSI, 1.6, 1.6 FSI, 1.9 TDI, 2.0 FSI, 2.0 TDI, 2.0 TDI 16V		<b>F8-7930</b>		d=18,5
Engine Mounting	1.9 TDI		<b>F8-7958</b>		
Engine Mounting	1.4 TSI		<b>F8-7959</b>		
Engine Mounting	1.4 TSI	05/2007 →	<b>F8-7959</b>		
Engine Mounting	1.4 16V, 1.4 FSI, 1.6, 1.6 BiFuel, 1.6 FSI, 1.6 MultiFuel		<b>F8-7960</b>		
Engine Mounting	1.4 TSI	6-speed	<b>F8-7960</b>		
Engine Mounting	1.6	ch.→1K-9-899999;  BSE, BSF;  6-speed	<b>F8-7961</b>		
Engine Mounting	1.6	ch.1K-9-900 001→;  BSE, BSF	<b>F8-7961</b>		
Engine Mounting	1.6 FSI, 2.0 FSI	6-speed	<b>F8-7961</b>		
Engine Mounting	1.9 TDI, 2.0 TDI, 2.0 TDI 16V	Transmission Type: DSG	<b>F8-7962</b>		
Engine Mounting	1.2 TSI, 1.4 16V, 1.4 FSI, 1.4 TSI, 1.6 FSI, 1.6 MultiFuel		<b>F8-7965</b>		
Engine Mounting	1.6		<b>F8-7965</b>		
Engine Mounting	1.6	ch.→1K-9-899999;  BSE, BSF	<b>F8-7966</b>		
Engine Mounting	1.9 TDI, 2.0 FSI, 2.0 TDI, 2.0 TDI 16V		<b>F8-7966</b>		
Engine Mounting	1.2 TSI, 1.4 16V, 1.4 FSI, 1.4 TSI, 1.6 BiFuel, 1.6 FSI, 1.6 TDI, 1.9 TDI, 2.0 TDI		<b>F8-7982</b>		
Engine Mounting	1.6	BSE, BSF, CCSA	<b>F8-7982</b>		
Engine Mounting	1.6 MultiFuel	CCSA	<b>F8-7982</b>		
Engine Mounting	2.0 FSI	BLR, BLY, BVZ	<b>F8-7982</b>		
Engine Mounting	2.0 TDI 16V	BKD	<b>F8-7982</b>		
Engine Mounting	2.0 TDI, 2.0 TDI 16V	6-speed	<b>F8-8152</b>		
<b>GOLF VI (5K1)</b>			<b>10/2008 → 11/2013</b>		
Dust Cover Kit, shock absorber	1.2 TSI, 1.4, 1.4 TSI, 1.6, 1.6 BiFuel, 1.6 MultiFuel, 1.6 TDI, 1.8 TSI, 2.0 GTi, 2.0 TDI	<b>ST</b>	<b>AK-735095</b>		
Alternator Freewheel Clutch	1.6, 1.6 BiFuel, 1.6 MultiFuel, 1.6 TDI, 2.0 GTi, 2.0 R 4motion, 2.0 TDI, 2.0 TDI 4motion		<b>F5-1004</b>		
Alternator Freewheel Clutch	1.8 TSI, 2.0 GTi		<b>F5-1044</b>		
Alternator Freewheel Clutch	1.2 TSI, 1.4 TSI		<b>F5-1064</b>		
Control Arm-/Trailing Arm Bush	1.2 TSI, 1.4, 1.4 TSI, 1.6, 1.6 BiFuel, 1.6 MultiFuel, 1.6 TDI, 1.8 TSI, 2.0 GTi, 2.0 R 4motion, 2.0 TDI, 2.0 TDI 4motion		<b>F8-5633</b>		
Rubber Buffer, suspension	1.2 TSI	for OE: G12; <b>SP</b>	<b>F8-6041</b>		H=53
Protective Cap/Bellow, shock absorber	1.2 TSI, 1.4, 1.4 TSI, 1.6, 1.6 BiFuel, 1.6 MultiFuel, 1.6 TDI, 1.8 TSI, 2.0 GTi, 2.0 R 4motion, 2.0 TDI, 2.0 TDI 4motion		<b>F8-6044</b>		H=160

<b>AK-735095</b>	<b>F5-1004</b>	<b>F5-1044</b>	<b>F5-1064</b>	<b>F8-5633</b>	<b>F8-6041</b>	<b>F8-6044</b>
Ref.Nr.: 1J0512131B	Ref.Nr.: 038903119T	Ref.Nr.: 06B903119B	Ref.Nr.: 03C903119D	Ref.Nr.: 1K0407182A	Ref.Nr.: 1J0412303	Ref.Nr.: 3C0513425
<b>F8-6284</b>	<b>F8-7930</b>	<b>F8-7958</b>	<b>F8-7959</b>	<b>F8-7960</b>	<b>F8-7961</b>	<b>F8-7962</b>
Ref.Nr.: 6N0412249C	Ref.Nr.: 1K0511327AP	Ref.Nr.: 1K0199262AS	Ref.Nr.: 1K0199262CG	Ref.Nr.: 1K0199555L	Ref.Nr.: 1K0199555N	Ref.Nr.: 1K0199555Q
<b>F8-7965</b>	<b>F8-7966</b>	<b>F8-7982</b>	<b>F8-8152</b>			
Ref.Nr.: 1K0199855BA	Ref.Nr.: 1K0199855BB	Ref.Nr.: 1K0199868Q	Ref.Nr.: 1K0199555T			

Article Description



Article Nr.

Fitting Position



GOLF VI (5K1)		10/2008 → 11/2013	
Top Strut Mounting	1.2 TSI, 1.4, 1.4 TSI, 1.6, 1.6 BiFuel, 1.6 MultiFuel, 1.6 TDI, 1.8 TSI, 2.0 GTI, 2.0 R 4motion, 2.0 TDI, 2.0 TDI 4motion		F8-6284
Top Strut Mounting	1.2 TSI, 1.4, 1.4 TSI, 1.6, 1.6 BiFuel, 1.6 TDI, 2.0 GTI, 2.0 TDI, 2.0 TDI 4motion	ST	F8-6348
Top Strut Mounting	1.2 TSI, 1.4, 1.4 TSI, 1.6, 1.6 BiFuel, 1.6 TDI, 2.0 GTI, 2.0 TDI, 2.0 TDI 4motion	SP	F8-6348
Top Strut Mounting	1.2 TSI, 1.4, 1.4 TSI, 1.6, 1.6 BiFuel, 1.6 TDI, 2.0 GTI, 2.0 TDI, 2.0 TDI 4motion	ch.→1K-9-587500;	F8-6349
Top Strut Mounting	2.0 TDI 4motion	ch.→1K-9-587500; ST	F8-6349
Top Strut Mounting	2.0 TDI 4motion	ch.→1K-9-587500; SP	F8-6349
Control Arm-/Trailing Arm Bush	1.2 TSI, 1.4, 1.4 TSI, 1.6, 1.6 BiFuel, 1.6 TDI, 2.0 GTI, 2.0 R 4motion, 2.0 TDI, 2.0 TDI 4motion	Aluminium	F8-6424
Control Arm-/Trailing Arm Bush	1.2 TSI, 1.4, 1.4 TSI, 1.6, 1.6 BiFuel, 1.6 TDI, 2.0 GTI, 2.0 R 4motion, 2.0 TDI, 2.0 TDI 4motion	Aluminium	F8-6425
Control Arm-/Trailing Arm Bush	1.2 TSI, 1.4, 1.4 TSI, 1.6, 1.6 BiFuel, 1.6 TDI, 2.0 GTI, 2.0 TDI, 2.0 TDI 4motion		F8-6463   H=64; d=12; D=60
Engine Mounting	1.4		F8-6531  H=117.7; L=165; W=149
Anti-Friction Bearing	1.2 TSI, 1.4, 1.4 TSI, 1.6, 1.6 BiFuel, 1.6 MultiFuel, 1.6 TDI, 1.8 TSI, 2.0 GTI, 2.0 R 4motion, 2.0 TDI, 2.0 TDI 4motion		F8-6569
Top Strut Mounting	1.2 TSI, 1.4, 1.4 TSI, 1.6, 1.6 BiFuel, 1.6 MultiFuel, 1.6 TDI, 1.8 TSI, 2.0 GTI, 2.0 R 4motion, 2.0 TDI, 2.0 TDI 4motion		F8-6570
Belt Pulley, crankshaft	1.6 TDI	Number of Ribs: 5; Parameter: 6PK	F8-6572
Belt Pulley, crankshaft	2.0 TDI	CFFA; Number of Ribs: 5; Parameter: 6PK	F8-6572
Belt Pulley, crankshaft	2.0 TDI	CFGB; Number of Ribs: 5; Parameter: 6PK	F8-6572
Belt Pulley, crankshaft	2.0 TDI	CLCA; Number of Ribs: 5; Parameter: 6PK	F8-6572
Belt Pulley, crankshaft	2.0 TDI, 2.0 TDI 4motion	CFFB; Number of Ribs: 5; Parameter: 6PK	F8-6572
Engine Mounting	1.8 TSI, 2.0 GTI		F8-6989
Rubber Buffer, suspension	1.2 TSI, 1.4, 1.4 TSI, 1.6, 1.6 BiFuel, 1.6 MultiFuel, 1.6 TDI, 1.8 TSI, 2.0 R 4motion, 2.0 TDI, 2.0 TDI 4motion	for OE: 2UA, G02, G07; ST	F8-7131   H=70
Rubber Buffer, suspension	2.0 GTI	for OE: G05, G11	F8-7131   H=70
Rubber Buffer, suspension	2.0 GTI, 2.0 R 4motion	for OE: G72, G73	F8-7131   H=70
Protective Cap/Bellow, shock absorber	1.2 TSI, 1.4, 1.4 TSI, 1.6, 1.6 BiFuel, 1.6 TDI, 1.8 TSI, 2.0 GTI, 2.0 R 4motion, 2.0 TDI, 2.0 TDI 4motion		F8-7132   H=190
Rubber Buffer, suspension	1.2 TSI, 1.8 TSI, 2.0 TDI	for OE: 1JB;	F8-7140   H=133
Rubber Buffer, suspension	1.4, 1.4 TSI, 1.6, 1.6 BiFuel, 1.6 MultiFuel, 1.6 TDI, 2.0 TDI	04/2009 →; for OE: 1JB;	F8-7140   H=133

<b>F8-6284</b>	<b>F8-6348</b>	<b>F8-6349</b>	<b>F8-6424</b>	<b>F8-6425</b>	<b>F8-6463</b>	<b>F8-6531</b>
Ref.Nr.: 6N0412249C	Ref.Nr.: 1K0513353G	Ref.Nr.: 1K0513353H	Ref.Nr.: 1K0199232G	Ref.Nr.: 1K0199231J	Ref.Nr.: 1K0505541B	Ref.Nr.: 1K0199262T
<b>F8-6569</b>	<b>F8-6570</b>	<b>F8-6572</b>	<b>F8-6989</b>	<b>F8-7131</b>	<b>F8-7132</b>	<b>F8-7140</b>
Ref.Nr.: 6N0412249C	Ref.Nr.: 1K0412331C	Ref.Nr.: 038105243L	Ref.Nr.: 1K0199262AM	Ref.Nr.: 1K0412303B	Ref.Nr.: 6N0413175A	Ref.Nr.: 3C0511359



**Article Description****Article Nr.****Fitting Position**

<b>GOLF VI (5K1)</b>			<b>10/2008 → 11/2013</b>		
Rubber Buffer, suspension	2.0 R 4motion, 2.0 TDI 4motion	for OE: 1JA, 1JB; $\Delta$ , <b>ST</b>	<b>F8-7140</b>		H=133
Rubber Buffer, suspension	1.2 TSI, 1.4, 1.4 TSI, 1.6, 1.6 BiFuel, 1.6 TDI, 1.8 TSI, 2.0 R 4motion, 2.0 TDI	for OE: 1JA, 1JM; $\Delta$ , <b>ST</b>	<b>F8-7576</b>		H=133
Rubber Buffer, suspension	2.0 GTi	for OE: 1JH, 1JM; $\Delta$ , <b>ST</b>	<b>F8-7576</b>		H=133
Rubber Buffer, suspension	1.2 TSI, 1.4, 1.4 TSI, 1.6, 1.6 BiFuel, 1.6 MultiFuel, 1.6 TDI, 1.8 TSI, 2.0 TDI	for OE: 1JC, 1JK; Shape Round; <b>SP</b>	<b>F8-7601</b>		H=118
Rubber Buffer, suspension	2.0 GTi	for OE: 1JE; Shape Round; <b>SP</b>	<b>F8-7601</b>		H=118
Top Strut Mounting	1.2 TSI, 1.4, 1.4 TSI, 1.6, 1.6 BiFuel, 1.6 MultiFuel, 1.6 TDI, 1.8 TSI, 2.0 TDI, 2.0 TDI 4motion	ch.1K-9-587501→; $\Delta$	<b>F8-7603</b>		
Top Strut Mounting	1.2 TSI, 1.4, 1.4 TSI, 1.6, 1.6 BiFuel, 1.6 MultiFuel, 1.6 TDI, 1.8 TSI, 2.0 TDI, 2.0 TDI 4motion	$\uparrow$	<b>F8-7603</b>		
Top Strut Mounting	2.0 TDI 4motion	ch.1K-9-587501→; <b>ST</b>	<b>F8-7603</b>		
Top Strut Mounting	2.0 TDI 4motion	ch.1K-9-587501→; <b>SP</b>	<b>F8-7603</b>		
Protective Cap/Bellow, shock absorber	1.2 TSI, 1.4, 1.4 TSI, 1.6, 1.6 BiFuel, 1.6 MultiFuel, 1.6 TDI, 1.8 TSI, 2.0 GTi, 2.0 TDI	for OE: 1JA, 1JC, 1JK; <b>SP</b> , <b>ST</b>	<b>F8-7640</b>		H=176
Rubber Buffer, suspension	1.2 TSI, 1.4, 1.4 TSI, 1.6, 1.6 BiFuel, 1.6 TDI, 1.8 TSI, 2.0 R 4motion, 2.0 TDI, 2.0 TDI 4motion	for OE: 2UC, G07; <b>SP</b>	<b>F8-7697</b>		H=55
Rubber Buffer, suspension	2.0 GTi	for OE: G08; <b>SP</b>	<b>F8-7697</b>		H=55
Rubber Buffer, suspension	1.2 TSI, 1.4, 1.4 TSI, 1.6, 1.6 BiFuel, 1.6 MultiFuel, 1.6 TDI, 1.8 TSI, 2.0 GTi, 2.0 R 4motion, 2.0 TDI, 2.0 TDI 4motion	for OE: 2UB, G02; $\Delta$	<b>F8-7703</b>		H=90; d=25
Rubber Buffer, suspension	2.0 R 4motion, 2.0 TDI 4motion	for OE: 1JC, 1JK; <b>SP</b>	<b>F8-7714</b>		H=118
Rubber Buffer, suspension	1.2 TSI, 1.4, 1.4 TSI, 1.6, 1.6 BiFuel, 1.8 TSI, 2.0 R 4motion, 2.0 TDI 4motion	for OE: 2UC, G02	<b>F8-7809</b>		H=55
Rubber Buffer, suspension	1.2 TSI, 1.4, 1.4 TSI, 1.6, 1.6 BiFuel, 1.8 TSI, 2.0 R 4motion, 2.0 TDI 4motion	for OE: G01, G03, G58; $\uparrow$	<b>F8-7809</b>		H=55
Rubber Buffer, suspension	1.2 TSI, 1.4, 1.4 TSI, 1.6, 1.6 BiFuel, 1.6 MultiFuel, 1.6 TDI, 1.8 TSI, 2.0 GTi, 2.0 R 4motion, 2.0 TDI, 2.0 TDI 4motion	for OE: 2UB, G07, G57; $\Delta$	<b>F8-7834</b>		H=90
Belt Pulley, crankshaft	1.8 TSI, 2.0 GTi	Number of Ribs: 5; Parameter: 6PK	<b>F8-7880</b>		D=143
Control Arm-/Trailing Arm Bush	1.2 TSI, 1.4, 1.4 TSI, 1.6, 1.6 BiFuel, 1.6 MultiFuel, 1.6 TDI, 1.8 TSI, 2.0 GTi, 2.0 R 4motion, 2.0 TDI, 2.0 TDI 4motion		<b>F8-7902</b>		H=60; d=12; D=42
Control Arm-/Trailing Arm Bush	1.2 TSI, 1.4, 1.4 TSI, 1.6, 1.6 BiFuel, 1.6 MultiFuel, 1.6 TDI, 1.8 TSI, 2.0 GTi, 2.0 R 4motion, 2.0 TDI, 2.0 TDI 4motion		<b>F8-7907</b>		H=45; d=14; D=38
Control Arm-/Trailing Arm Bush	1.2 TSI, 1.4, 1.4 TSI, 1.6, 1.6 BiFuel, 1.6 MultiFuel, 1.6 TDI, 1.8 TSI, 2.0 GTi, 2.0 R 4motion, 2.0 TDI, 2.0 TDI 4motion		<b>F8-7908</b>		H=45; d=12; D=38
Control Arm-/Trailing Arm Bush	1.2 TSI, 1.4, 1.4 TSI, 1.6, 1.6 BiFuel, 1.6 MultiFuel, 1.6 TDI, 1.8 TSI, 2.0 GTi, 2.0 R 4motion, 2.0 TDI, 2.0 TDI 4motion		<b>F8-7909</b>		
Stabiliser Mounting	1.2 TSI, 1.4, 1.4 TSI, 1.6, 1.6 BiFuel, 1.6 TDI, 2.0 GTi, 2.0 TDI, 2.0 TDI 4motion		<b>F8-7923</b>		d=20,7



Article Description



Article Nr.

Fitting Position



<b>GOLF VI (5K1)</b>			10/2008 → 11/2013	
Engine Mounting	1.4, 1.4 TSI, 1.6, 1.6 BiFuel, 1.6 MultiFuel		<b>F8-7960</b>	
Engine Mounting	1.6	BSE, BSF	<b>F8-7961</b>	
Engine Mounting	1.6 TDI		<b>F8-7961</b>	
Engine Mounting	1.2 TSI, 1.4, 1.4 TSI, 1.6, 1.6 BiFuel		<b>F8-7965</b>	
Engine Mounting	1.4		<b>F8-7981</b>	
Engine Mounting	1.6	Transmission Type: Dual-clutch transmission	<b>F8-7981</b>	
Engine Mounting	1.2 TSI, 1.4, 1.4 TSI, 1.6, 1.6 BiFuel, 1.6 TDI, 1.8 TSI, 2.0 GTi, 2.0 R 4motion, 2.0 TDI, 2.0 TDI 4motion		<b>F8-7982</b>	
Engine Mounting	1.6 MultiFuel	CMXA	<b>F8-7982</b>	
Engine Mounting	2.0 GTi	CBFA, CCTA	<b>F8-7982</b>	
Engine Mounting	2.0 TDI, 2.0 TDI 4motion		<b>F8-8152</b>	
<b>GOLF VI Convertible (517)</b>			03/2011 →	
Dust Cover Kit, shock absorber	1.2 TSI, 1.2 TSI 16V, 1.4 TSI, 1.6 TDI, 2.0 R, 2.0 TDI, 2.0 TSI	ST	<b>AK-735095</b>	
Alternator Freewheel Clutch	1.6 TDI, 2.0 R, 2.0 TDI		<b>F5-1004</b>	
Alternator Freewheel Clutch	2.0 TSI		<b>F5-1044</b>	
Alternator Freewheel Clutch	1.2 TSI, 1.4 TSI		<b>F5-1064</b>	
Control Arm-/Trailing Arm Bush	1.2 TSI, 1.4 TSI, 1.6 TDI, 2.0 TDI, 2.0 TSI		<b>F8-5633</b>	
Rubber Buffer, suspension	1.2 TSI	for OE: G12; SP	<b>F8-6041</b>	H=53
Protective Cap/Bellow, shock absorber	1.2 TSI, 1.4 TSI, 1.6 TDI, 2.0 TDI, 2.0 TSI		<b>F8-6044</b>	H=160
Top Strut Mounting	1.2 TSI, 1.4 TSI, 1.6 TDI, 2.0 TDI, 2.0 TSI		<b>F8-6284</b>	
Anti-Friction Bearing	1.2 TSI, 1.4 TSI, 1.6 TDI, 2.0 TDI, 2.0 TSI		<b>F8-6569</b>	
Top Strut Mounting	1.2 TSI, 1.4 TSI, 1.6 TDI, 2.0 TDI, 2.0 TSI	for OE: G09, G25, G26;	<b>F8-6570</b>	
Belt Pulley, crankshaft	1.6 TDI, 2.0 TDI	Number of Ribs: 5; Parameter: 6PK	<b>F8-6572</b>	
Engine Mounting	2.0 TSI		<b>F8-6989</b>	
Rubber Buffer, suspension	1.2 TSI, 1.4 TSI, 1.6 TDI, 2.0 TDI, 2.0 TSI	for OE: 2UA, G24; ☆	<b>F8-7131</b>	H=70
Protective Cap/Bellow, shock absorber	1.2 TSI, 1.4 TSI, 1.6 TDI, 2.0 TDI, 2.0 TSI		<b>F8-7132</b>	H=190
Rubber Buffer, suspension	1.2 TSI, 1.4 TSI, 1.6 TDI, 2.0 TDI, 2.0 TSI	for OE: 1JA; , ST	<b>F8-7576</b>	H=133
Rubber Buffer, suspension	1.2 TSI, 1.4 TSI, 1.6 TDI, 2.0 TDI, 2.0 TSI	for OE: 1JC, 1JK; Shape Round; SP	<b>F8-7601</b>	H=118
Top Strut Mounting	1.2 TSI, 1.4 TSI, 1.6 TDI, 2.0 R, 2.0 TDI, 2.0 TSI	for OE: 1JP;	<b>F8-7603</b>	
Top Strut Mounting	2.0 R	for OE: 1JR; SP	<b>F8-7603</b>	
Protective Cap/Bellow, shock absorber	2.0 R	for OE: 1JR; SP	<b>F8-7627</b>	H=178

<b>AK-735095</b>	<b>F5-1004</b>	<b>F5-1044</b>	<b>F5-1064</b>	<b>F8-5633</b>	<b>F8-6041</b>	<b>F8-6044</b>
Ref.Nr.: 1J0512131B	Ref.Nr.: 038903119T	Ref.Nr.: 06B903119B	Ref.Nr.: 03C903119D	Ref.Nr.: 1K0407182A	Ref.Nr.: 1J0412303	Ref.Nr.: 3C0513425
<b>F8-6284</b>	<b>F8-6569</b>	<b>F8-6570</b>	<b>F8-6572</b>	<b>F8-6989</b>	<b>F8-7131</b>	<b>F8-7132</b>
Ref.Nr.: 6N0412249C	Ref.Nr.: 6N0412249C	Ref.Nr.: 1K0412331C	Ref.Nr.: 038105243L	Ref.Nr.: 1K0199262AM	Ref.Nr.: 1K0412303B	Ref.Nr.: 6N0413175A
<b>F8-7576</b>	<b>F8-7601</b>	<b>F8-7603</b>	<b>F8-7627</b>	<b>F8-7640</b>	<b>F8-7960</b>	<b>F8-7961</b>
Ref.Nr.: 1K0 511 353 M	Ref.Nr.: 1K0511353N	Ref.Nr.: 3C0513353	Ref.Nr.: 1K0513425D	Ref.Nr.: 1K0513425A	Ref.Nr.: 1K0199555L	Ref.Nr.: 1K0199555N



Article Description



Article Nr.

Fitting Position



<b>GOLF VI Convertible (517)</b>				<b>03/2011 →</b>	
Protective Cap/Bellow, shock absorber	1.2 TSI, 1.4 TSI, 1.6 TDI, 2.0 TDI	for OE: 1JA, 1JC, 1JK; <b>SP, ST</b>	<b>F8-7640</b>		H=176
Protective Cap/Bellow, shock absorber	2.0 TSI	for OE: 1JE, 1JF, 1JH; <b>SP</b>	<b>F8-7640</b>		H=176
Rubber Buffer, suspension	1.2 TSI, 1.4 TSI, 1.6 TDI, 2.0 TDI, 2.0 TSI	for OE: 2UC, G07, G25; <b>SP</b>	<b>F8-7697</b>		H=55
Rubber Buffer, suspension	1.2 TSI, 1.4 TSI, 1.6 TDI, 2.0 TDI, 2.0 TSI	for OE: G01, G58; <b>ST</b>	<b>F8-7809</b>		H=55
Belt Pulley, crankshaft	2.0 TSI	Number of Ribs: 5; Parameter: 6PK	<b>F8-7880</b>		D=143
Engine Mounting	1.4 TSI	6-speed	<b>F8-7960</b>		
Engine Mounting	1.2 TSI, 1.4 TSI, 1.6 TDI, 2.0 R, 2.0 TDI, 2.0 TSI		<b>F8-7982</b>		
<b>GOLF VI Variant (AJ5)</b>				<b>07/2009 → 07/2013</b>	
Alternator Freewheel Clutch	1.6, 1.6 MultiFuel, 1.6 TDI, 1.6 TDI 4motion, 2.0 TDI, 2.0 TDI 16V		<b>F5-1004</b>		
Alternator Freewheel Clutch	1.2 TSI, 1.4 TSI		<b>F5-1064</b>		
Control Arm-/Trailing Arm Bush	1.2 TSI, 1.4, 1.4 TSI, 1.6, 1.6 MultiFuel, 1.6 TDI, 1.6 TDI 4motion, 2.0 TDI, 2.0 TDI 16V		<b>F8-5633</b>		
Rubber Buffer, suspension	1.2 TSI	for OE: G12; <b>SP</b>	<b>F8-6041</b>		H=53
Protective Cap/Bellow, shock absorber	All Models		<b>F8-6044</b>		H=160
Top Strut Mounting	All Models		<b>F8-6284</b>		
Top Strut Mounting	1.2 TSI, 1.4, 1.4 TSI, 1.6, 1.6 TDI, 1.6 TDI 4motion, 2.0 TDI 16V	for OE: 1K0513353H; Shape Oval	<b>F8-6349</b>		
Control Arm-/Trailing Arm Bush	1.2 TSI, 1.4, 1.4 TSI, 1.6, 1.6 TDI, 1.6 TDI 4motion, 2.0 TDI 16V	Aluminium	<b>F8-6424</b>		
Control Arm-/Trailing Arm Bush	1.2 TSI, 1.4, 1.4 TSI, 1.6, 1.6 TDI, 1.6 TDI 4motion, 2.0 TDI 16V	Aluminium	<b>F8-6425</b>		
Engine Mounting	1.4, 1.6		<b>F8-6531</b>		H=117.7; L=165; W=149
Anti-Friction Bearing	All Models		<b>F8-6569</b>		
Top Strut Mounting	All Models		<b>F8-6570</b>		
Belt Pulley, crankshaft	1.6 TDI, 1.6 TDI 4motion, 2.0 TDI	Number of Ribs: 5; Parameter: 6PK	<b>F8-6572</b>		
Belt Pulley, crankshaft	2.0 TDI	CFHB; Number of Ribs: 5; Parameter: 6PK	<b>F8-6572</b>		
Belt Pulley, crankshaft	2.0 TDI 16V	CFHC; Number of Ribs: 5; Parameter: 6PK	<b>F8-6572</b>		
Protective Cap/Bellow, shock absorber	1.2 TSI, 1.4, 1.4 TSI, 1.6, 1.6 TDI, 1.6 TDI 4motion, 2.0 TDI, 2.0 TDI 16V		<b>F8-7132</b>		H=190
Rubber Buffer, suspension	1.2 TSI, 1.4, 1.4 TSI, 1.6, 1.6 MultiFuel, 1.6 TDI, 2.0, 2.0 TDI, 2.0 TDI 16V	02/2012 →; for OE: 1JA, 1JB; <b>ST</b>	<b>F8-7140</b>		H=133
Rubber Buffer, suspension	1.2 TSI, 1.4, 1.4 TSI, 1.6, 1.6 MultiFuel, 1.6 TDI, 2.0, 2.0 TDI, 2.0 TDI 16V	for OE: 1JM, UA1; <b>ST</b>	<b>F8-7140</b>		H=133
Rubber Buffer, suspension	1.6 TDI 4motion	02/2012 →; for OE: 1JB; <b>ST</b>	<b>F8-7140</b>		H=133
Rubber Buffer, suspension	1.6 TDI 4motion	for OE: 1JA; <b>ST</b>	<b>F8-7140</b>		H=133

<b>F5-1004</b>	<b>F5-1064</b>	<b>F8-5633</b>	<b>F8-6041</b>	<b>F8-6044</b>	<b>F8-6284</b>	<b>F8-6349</b>
Ref.Nr.: 038903119T	Ref.Nr.: 03C903119D	Ref.Nr.: 1K0407182A	Ref.Nr.: 1J0412303	Ref.Nr.: 3C0513425	Ref.Nr.: 6N0412249C	Ref.Nr.: 1K0513353H
<b>F8-6424</b>	<b>F8-6425</b>	<b>F8-6531</b>	<b>F8-6569</b>	<b>F8-6570</b>	<b>F8-6572</b>	<b>F8-7132</b>
Ref.Nr.: 1K0199232G	Ref.Nr.: 1K0199231J	Ref.Nr.: 1K0199262T	Ref.Nr.: 6N0412249C	Ref.Nr.: 1K0412331C	Ref.Nr.: 038105243L	Ref.Nr.: 6N0413175A
<b>F8-7140</b>	<b>F8-7576</b>	<b>F8-7640</b>	<b>F8-7697</b>	<b>F8-7809</b>	<b>F8-7880</b>	<b>F8-7960</b>
Ref.Nr.: 3C0511359	Ref.Nr.: 1K0 511 353 M	Ref.Nr.: 1K0513425A	Ref.Nr.: 1K0412303F	Ref.Nr.: 1K0412303E	Ref.Nr.: 06H105243F	Ref.Nr.: 1K0199555L

**Article Description**

**Article Nr.**
**Fitting Position**

<b>GOLF VI Variant (AJ5)</b>				<b>07/2009 → 07/2013</b>	
Rubber Buffer, suspension	1.2 TSI, 1.4, 1.4 TSI, 1.6, 1.6 TDI, 2.0 TDI, 2.0 TDI 16V	for OE: 1JA, 4P1;	<b>F8-7576</b>		H=133
Top Strut Mounting	All Models	for OE: 1K0513353R, 3C0513353C; Shape Round	<b>F8-7603</b>		
Protective Cap/Bellow, shock absorber	1.2 TSI, 1.4, 1.4 TSI, 1.6, 1.6 MultiFuel, 1.6 TDI, 2.0 TDI, 2.0 TDI 16V	for OE: 1JA, 1JC, 1JK;	<b>F8-7640</b>		H=176
Rubber Buffer, suspension	1.2 TSI, 1.4, 1.4 TSI, 1.6, 1.6 TDI, 1.6 TDI 4motion, 2.0 TDI, 2.0 TDI 16V	for OE: 2UC, G57, G68;	<b>F8-7697</b>		H=55
Rubber Buffer, suspension	1.2 TSI, 1.4, 1.4 TSI, 1.6, 1.6 MultiFuel, 1.6 TDI, 1.6 TDI 4motion, 2.0 TDI, 2.0 TDI 16V	for OE: 2UB, G02, G56;	<b>F8-7703</b>		H=90; d=25
Rubber Buffer, suspension	1.2 TSI, 1.4, 1.4 TSI, 1.6, 1.6 MultiFuel, 1.6 TDI, 2.0 TDI, 2.0 TDI 16V	02/2012 →; for OE: 1JC, 1JK;	<b>F8-7714</b>		H=118
Rubber Buffer, suspension	1.6 TDI 4motion	for OE: 1JC, 1JK;	<b>F8-7714</b>		H=118
Rubber Buffer, suspension	1.2 TSI, 1.4, 1.4 TSI, 1.6, 1.6 TDI, 1.6 TDI 4motion, 2.0 TDI, 2.0 TDI 16V	for OE: 2UC, G56	<b>F8-7809</b>		H=55
Rubber Buffer, suspension	All Models	for OE: 2UB, G07, G57;	<b>F8-7834</b>		H=90
Engine Mounting	2.0	Aluminium	<b>F8-7851</b>		
Belt Pulley, crankshaft	2.0	Number of Ribs: 5; Parameter: 6PK	<b>F8-7880</b>		D=143
Rubber Buffer, suspension	1.2 TSI, 1.4, 1.4 TSI, 1.6, 1.6 MultiFuel, 1.6 TDI, 2.0, 2.0 TDI, 2.0 TDI 16V	for OE: 1JC, 1JK; Shape Oval;	<b>F8-7897</b>		H=118
Control Arm-/Trailing Arm Bush	1.2 TSI, 1.4, 1.4 TSI, 1.6, 1.6 MultiFuel, 1.6 TDI, 1.6 TDI 4motion, 2.0 TDI, 2.0 TDI 16V		<b>F8-7902</b>		H=60; d=12; D=42
Control Arm-/Trailing Arm Bush	1.2 TSI, 1.4, 1.4 TSI, 1.6, 1.6 MultiFuel, 1.6 TDI, 1.6 TDI 4motion, 2.0 TDI, 2.0 TDI 16V		<b>F8-7907</b>		H=45; d=14; D=38
Control Arm-/Trailing Arm Bush	1.2 TSI, 1.4, 1.4 TSI, 1.6, 1.6 MultiFuel, 1.6 TDI, 1.6 TDI 4motion, 2.0 TDI, 2.0 TDI 16V		<b>F8-7908</b>		H=45; d=12; D=38
Control Arm-/Trailing Arm Bush	1.2 TSI, 1.4, 1.4 TSI, 1.6, 1.6 MultiFuel, 1.6 TDI, 1.6 TDI 4motion, 2.0 TDI, 2.0 TDI 16V		<b>F8-7909</b>		
Engine Mounting	1.4 TSI	6-speed	<b>F8-7960</b>		
Engine Mounting	1.4, 1.6 MultiFuel		<b>F8-7960</b>		
Engine Mounting	1.6	5-speed	<b>F8-7960</b>		
Engine Mounting	1.4, 1.4 TSI, 1.6, 1.6 MultiFuel, 2.0 TDI		<b>F8-7981</b>		
Engine Mounting	1.2 TSI, 1.4, 1.6, 1.6 MultiFuel, 1.6 TDI, 1.6 TDI 4motion, 2.0, 2.0 TDI		<b>F8-7982</b>		
Engine Mounting	2.0 TDI 16V	CBDB, CFHC	<b>F8-7982</b>		
Engine Mounting	1.6 TDI 4motion, 2.0 TDI	Transmission Type: MQ350	<b>F8-8152</b>		
Engine Mounting	2.0 TDI	CBDA;  6-speed	<b>F8-8152</b>		
Engine Mounting	2.0 TDI	CFHB; Transmission Type: MQ350	<b>F8-8152</b>		
Engine Mounting	2.0 TDI 16V	CBDB;  6-speed	<b>F8-8152</b>		
Engine Mounting	2.0 TDI 16V	CFHC; Transmission Type: MQ350	<b>F8-8152</b>		

<b>F5-1085</b>	<b>F8-7576</b>	<b>F8-7603</b>	<b>F8-7640</b>	<b>F8-7697</b>	<b>F8-7703</b>	<b>F8-7714</b>
Ref.Nr.: 045903119A	Ref.Nr.: 1K0 511 353 M	Ref.Nr.: 3C0513353	Ref.Nr.: 1K0513425A	Ref.Nr.: 1K0412303F	Ref.Nr.: 1K0412303G	Ref.Nr.: 3C0511359B
<b>F8-7809</b>	<b>F8-7834</b>	<b>F8-7851</b>	<b>F8-7880</b>	<b>F8-7897</b>	<b>F8-7902</b>	<b>F8-7907</b>
Ref.Nr.: 1K0412303E	Ref.Nr.: 1K0412303H	Ref.Nr.: 3C0199855A	Ref.Nr.: 06H105243F	Ref.Nr.: 1K0511353F	Ref.Nr.: 1K0505171C	Ref.Nr.: 1K0505203A
<b>F8-7908</b>	<b>F8-7909</b>	<b>F8-7960</b>	<b>F8-7981</b>	<b>F8-7982</b>	<b>F8-8152</b>	
Ref.Nr.: 1K0505279A	Ref.Nr.: 1K0505553 A	Ref.Nr.: 1K0199555L	Ref.Nr.: 1K0199867Q	Ref.Nr.: 1K0199868Q	Ref.Nr.: 1K0199555T	

**Article Description****Article Nr.****Fitting Position**

<b>GOLF VII (5G1, BE1)</b>			<b>08/2012 →</b>		
Alternator Freewheel Clutch	2.0 GTD, 2.0 TDI		<b>F5-1085</b>		
Rubber Buffer, suspension	1.2 TSI, 1.4 TSI, 1.4 TSI E85-100, 1.6 TDI, 1.6 TDI 4motion, 2.0 TDI, 2.0 TDI 4motion	for OE: 2UA, G01, G02; <b>ST</b>	<b>F8-7131</b>		H=70
Rubber Buffer, suspension	2.0 GTI	<b>CD</b> , <b>RD</b> ; for OE: 2UN, G06	<b>F8-7131</b>		H=70
Rubber Buffer, suspension	1.2 TSI, 1.4 TSI, 1.4 TSI E85-100, 1.6 TDI, 1.6 TDI 4motion, 2.0 TDI, 2.0 TDI 4motion	for OE: G02+2UC; <b>SP</b>	<b>F8-7697</b>		H=55
Rubber Buffer, suspension	2.0 GTI	for OE: G06; <b>SP</b>	<b>F8-7697</b>		H=55
Rubber Buffer, suspension	1.2 TSI, 1.4 TSI, 1.4 TSI E85-100, 1.6 TDI, 1.6 TDI 4motion, 2.0 TDI, 2.0 TDI 4motion	BlueMotion; for OE: 2UP, G01; <b>ST</b>	<b>F8-7809</b>		H=55
Rubber Buffer, suspension	1.2 TSI, 1.4 TSI, 1.4 TSI E85-100, 1.6 TDI, 1.6 TDI 4motion, 2.0 TDI, 2.0 TDI 4motion	for OE: 2UC, G01; <b>SP</b>	<b>F8-7809</b>		H=55
Rubber Buffer, suspension	1.2 TSI, 1.4 TSI, 1.4 TSI E85-100, 1.6 TDI, 1.6 TDI 4motion, 2.0 TDI, 2.0 TDI 4motion	$\uparrow$	<b>F8-7809</b>		H=55
Rubber Buffer, suspension	2.0 GTD	for OE: G05; $\uparrow$	<b>F8-7809</b>		H=55
<b>GOLF VII Estate (BA5)</b>			<b>04/2013 →</b>		
Alternator Freewheel Clutch	1.6 TDI, 1.6 TDI 4motion, 2.0 TDI, 2.0 TDI 4motion		<b>F5-1085</b>		
<b>ILTIS (183)</b>			<b>03/1979 → 12/1988</b>		
Mounting, radiator	All Models		<b>F8-4009</b>		H1=15; H2=37; D=39; Outer Thread [mm]=M8 x 1,50
<b>JETTA (16)</b>			<b>08/1978 → 02/1984</b>		
Dust Cover Kit, shock absorber	1.3, 1.6, 1.6 TD	08/1983 →; $\Delta$	<b>AK-732516</b>		
Dust Cover Kit, shock absorber	1.1, 1.3, 1.5, 1.5 D, 1.6, 1.6 D, 1.6 GLI, 1.6 TD, 1.8		<b>AK-733023</b>		
Dust Cover Kit, shock absorber	1.1, 1.3, 1.5, 1.5 D, 1.6, 1.6 D, 1.6 GLI, 1.6 TD, 1.8		<b>AK-735006</b>		
Engine Mounting	1.5, 1.6 GLI		<b>F8-1001</b>		H1=42; H2=61; d=11; D=74.5
Engine Mounting	1.6	Engine028657→	<b>F8-1001</b>		H1=42; H2=61; d=11; D=74.5
Engine Mounting	1.6 D, 1.6 TD		<b>F8-1001</b>		H1=42; H2=61; d=11; D=74.5
Top Strut Mounting	1.1, 1.3, 1.5, 1.5 D, 1.6, 1.6 D, 1.6 GLI, 1.6 TD	with slide bearing	<b>F8-1002</b>		
Top Strut Mounting	1.8	DX; with slide bearing	<b>F8-1002</b>		
Anti-Friction Bearing	1.1, 1.3, 1.5, 1.5 D, 1.6, 1.6 D, 1.6 GLI, 1.6 TD, 1.8		<b>F8-3036</b>		
Flange, carburettor	1.6	Engine028658→	<b>F8-3046</b>		H=23
Flange, carburettor	1.1, 1.3		<b>F8-4013</b>		H1=84; H2=95; d=36; $\tau$ [mm]=68
Rubber Buffer, silencer	1.1		<b>F8-4026</b>		H=12; W=57, 60
Clamp, silencer	1.1, 1.3, 1.5, 1.6, 1.6 D, 1.6 GLI, 1.6 TD, 1.8		<b>F8-4027</b>		H=17; W=53, 61
Protective Cap/Bellow, shock absorber	1.1, 1.3, 1.5, 1.6, 1.6 D, 1.6 GLI, 1.6 TD, 1.8		<b>F8-4064</b>		H=90; d1=50; d2=71; D1=66; D2=77
Bellow Set, steering	1.1, 1.3, 1.5, 1.5 D, 1.6, 1.6 D, 1.6 GLI, 1.6 TD, 1.8	for OE: 171419832A	<b>F8-4074</b>		H=125; D1=34; D2=39
Bellow, driveshaft	1.5, 1.5 D, 1.6, 1.6 D, 1.6 TD, 1.8		<b>F8-4080</b>		H=95; D1=29; D2=96

<b>AK-732516</b>	<b>AK-733023</b>	<b>AK-735006</b>	<b>F5-1085</b>	<b>F8-1001</b>	<b>F8-1002</b>	<b>F8-3036</b>
Ref.Nr.:	Ref.Nr.: 191412303	Ref.Nr.:	Ref.Nr.: 045903119A	Ref.Nr.: 171199214K	Ref.Nr.: 171412329A	Ref.Nr.: 377412335A
<b>F8-3046</b>	<b>F8-4009</b>	<b>F8-4013</b>	<b>F8-4026</b>	<b>F8-4027</b>	<b>F8-4064</b>	<b>F8-4074</b>
Ref.Nr.: 049129761	Ref.Nr.: 431121273	Ref.Nr.: 052129765A	Ref.Nr.: 817253147	Ref.Nr.: 171253147A	Ref.Nr.: 191412135	Ref.Nr.: 171419832A
<b>F8-4080</b>	<b>F8-5146</b>	<b>F8-7131</b>	<b>F8-7697</b>	<b>F8-7809</b>		
Ref.Nr.: 113501149	Ref.Nr.: 171411314A	Ref.Nr.: 1K0412303B	Ref.Nr.: 1K0412303F	Ref.Nr.: 1K0412303E		

**Article Description**

**Article Nr.**
**Fitting Position**

<b>JETTA (16)</b>			<b>08/1978 → 02/1984</b>		
Stabiliser Mounting	1.6 GLI, 1.8		<b>F8-5146</b>		D=15
Stabiliser Mounting	1.6 GLI, 1.8		<b>F8-5147</b>		D=15
Rubber Buffer, suspension	1.1, 1.3, 1.5, 1.6, 1.6 D, 1.6 GLI, 1.6 TD, 1.8		<b>F8-5755</b>		
Bellow, driveshaft	1.1, 1.3, 1.5, 1.6, 1.6 D, 1.6 TD, 1.8		<b>F8-7722</b>		d1=26; d2=78; L=110
Bellow, driveshaft	1.6, 1.6 GLI	ch.16A0360001→	<b>F8-7722</b>		d1=26; d2=78; L=110
Control Arm-/Trailing Arm Bush	1.1, 1.3, 1.5, 1.5 D, 1.6, 1.6 D, 1.6 GLI, 1.6 TD, 1.8		<b>G9-540</b>		H=55; d=16; D=38
Control Arm-/Trailing Arm Bush	1.1, 1.3, 1.5, 1.5 D, 1.6, 1.6 D, 1.6 GLI, 1.6 TD, 1.8		<b>G9-541</b>		H=62; d=12; D=34
Bellow, steering	1.1, 1.3, 1.5, 1.6, 1.6 D, 1.6 GLI, 1.6 TD	ch.16-E-431736→; ch.→16-F-990000; with clamps;	<b>LM-10003S</b>		d1=9; d2=43; L [mm]=210
Bellow, steering	1.3, 1.5 D, 1.8	with clamps;	<b>LM-10003S</b>		d1=9; d2=43; L [mm]=210
Bellow, steering	1.3, 1.5 D, 1.8	with clamps;	<b>LM-10003S</b>		d1=9; d2=43; L [mm]=210
Bellow, steering	1.1, 1.3, 1.5, 1.5 D, 1.6, 1.6 D, 1.6 GLI, 1.6 TD, 1.8	with clamps	<b>LM-10006S</b>		d1=10; d2=41; L [mm]=210
Bellow, steering	1.1, 1.3, 1.5, 1.5 D, 1.6, 1.6 D, 1.6 GLI, 1.6 TD, 1.8	with clamps;	<b>LM-10024S</b>		d1=25; d2=41; L [mm]=120
Bellow, steering	1.1, 1.3, 1.5, 1.5 D, 1.6, 1.6 D, 1.6 GLI, 1.6 TD, 1.8	with clamps;	<b>LM-10050S</b>		d1=25; d2=39; L [mm]=126
Bellow, steering	1.1	GG; with clamps	<b>LM-10064S</b>		d1=25; d2=35; L [mm]=144
Bellow, steering	1.3, 1.5, 1.6, 1.6 D, 1.6 GLI, 1.6 TD, 1.8	with clamps	<b>LM-10064S</b>		d1=25; d2=35; L [mm]=144
Bellow, driveshaft	1.1, 1.3, 1.5, 1.6, 1.6 D, 1.6 GLI, 1.6 TD, 1.8		<b>M-830220</b>		
Bellow Set, drive shaft	1.1, 1.3, 1.5, 1.6, 1.6 D, 1.6 TD, 1.8		<b>MK-830220</b>		
Bellow Set, drive shaft	1.6, 1.6 GLI	ch.16A0360001→	<b>MK-830220</b>		
Bellow Set, drive shaft	1.3, 1.5, 1.6, 1.6 TD		<b>MK-830220S</b>		
<b>JETTA Mk II (19E, 1G2, 165)</b>			<b>01/1984 → 07/1992</b>		
Dust Cover Kit, shock absorber	1.3, 1.3 CAT, 1.6, 1.6 D, 1.6 TD, 1.8, 1.8 16V, 1.8 CAT, 1.8 Syncro		<b>AK-732516</b>		
Dust Cover Kit, shock absorber	1.3, 1.3 CAT, 1.6, 1.6 D, 1.6 TD, 1.8, 1.8 16V, 1.8 CAT, 1.8 Syncro		<b>AK-733023</b>		
Engine Mounting	1.3, 1.3 CAT, 1.6, 1.6 D, 1.6 TD, 1.8, 1.8 CAT, 1.8 Syncro		<b>F8-1003</b>		H=120; d=11; D=106; Thick [mm]=62, 76
Engine Mounting	1.8 16V	ch.→16-JB125000, 16-JW400000, 19-JB125000, 19-JW400000	<b>F8-1003</b>		H=120; d=11; D=106; Thick [mm]=62, 76
Engine Mounting	1.3, 1.6 D, 1.6 TD, 1.8 Syncro		<b>F8-1004</b>		H=114; D=106
Engine Mounting	1.6, 1.8, 1.8 16V, 1.8 CAT	ch.→19-H-990000	<b>F8-1004</b>		H=114; D=106
Engine Mounting	1.8	ch.→19-H-990000;  EV	<b>F8-1004</b>		H=114; D=106
Engine Mounting	1.3, 1.3 CAT, 1.8 Syncro		<b>F8-1005</b>		H=109; d1=6; d2=12; D=116
Engine Mounting	1.6, 1.8, 1.8 CAT		<b>F8-1005</b>		H=109; d1=6; d2=12; D=116
Engine Mounting	1.8	01/1987 →	<b>F8-1005</b>		H=109; d1=6; d2=12; D=116

<b>AK-732516</b>	<b>AK-733023</b>	<b>F8-1003</b>	<b>F8-1004</b>	<b>F8-1005</b>	<b>F8-5146</b>	<b>F8-5147</b>
Ref.Nr.:	Ref.Nr.: 191412303	Ref.Nr.: 191199262A	Ref.Nr.: 357199279C	Ref.Nr.: 191199279E	Ref.Nr.: 171411314A	Ref.Nr.: 171411313
<b>F8-5755</b>	<b>F8-7722</b>	<b>G9-540</b>	<b>G9-541</b>	<b>LM-10003S</b>	<b>LM-10006S</b>	<b>LM-10024S</b>
Ref.Nr.: 171412303C	Ref.Nr.: 191407285F	Ref.Nr.: 171407181A	Ref.Nr.: 171407182D	Ref.Nr.: 357422831A	Ref.Nr.: 1H0422831B	Ref.Nr.: 171419831B
<b>LM-10050S</b>	<b>LM-10064S</b>	<b>M-830220</b>	<b>MK-830220</b>	<b>MK-830220S</b>		
Ref.Nr.: 171419831C	Ref.Nr.: 171419832C	Ref.Nr.: 191498203C	Ref.Nr.: 171498203	Ref.Nr.:		

**Article Description****Article Nr.****Fitting Position**

<b>JETTA Mk II (19E, 1G2, 165)</b>			<b>01/1984 → 07/1992</b>		
Engine Mounting	1.8 16V	01/1988 →	<b>F8-1005</b>		H=109; d1=6; d2=12; D=116
Engine Mounting	1.6, 1.6 D, 1.6 TD, 1.8, 1.8 16V, 1.8 CAT	ch.16-E-300001, 19-E-300001→	<b>F8-1006</b>		H=86; D1=45; D2=71; T [mm]=105
Control Arm-/Trailing Arm Bush	1.3, 1.3 CAT, 1.6, 1.6 D, 1.6 TD, 1.8, 1.8 16V, 1.8 CAT, 1.8 Syncro	without guide sleeve	<b>F8-1007</b>		H1=26; H2=41; d=17; D1=60; D2=68
Control Arm-/Trailing Arm Bush	1.3, 1.3 CAT, 1.6, 1.6 D, 1.6 TD, 1.8, 1.8 16V, 1.8 CAT, 1.8 Syncro	with guide sleeve	<b>F8-1007S</b>		H1=26; H2=41; d=17; D1=60; D2=68
Repair Kit, link	1.3, 1.3 CAT, 1.6, 1.6 D, 1.6 TD, 1.8, 1.8 16V, 1.8 CAT, 1.8 Syncro	with guide sleeve	<b>F8-1008</b>		H1=24; H2=41; d=17; D=60
Top Strut Mounting	1.3, 1.3 CAT, 1.6, 1.6 D, 1.6 TD, 1.8, 1.8 CAT, 1.8 Syncro		<b>F8-1009B</b>		d=14; D=132
Top Strut Mounting	1.8 16V		<b>F8-1009C</b>		H1=39; H2=55; d=14; D=127
Mounting, axle beam	1.3, 1.3 CAT, 1.6, 1.6 D, 1.6 TD, 1.8, 1.8 16V, 1.8 CAT, 1.8 Syncro		<b>F8-1010</b>		H=90; d=12; D1=22; D2=44
Repair Set, axle beam	1.3, 1.3 CAT, 1.6, 1.6 D, 1.6 TD, 1.8, 1.8 16V, 1.8 CAT, 1.8 Syncro		<b>F8-1010S</b>		
Engine Mounting	1.8 16V		<b>F8-1025</b>		H=128; D=100; W=180
Anti-Friction Bearing	1.3, 1.3 CAT, 1.6, 1.6 D, 1.6 TD, 1.8, 1.8 16V, 1.8 CAT, 1.8 Syncro		<b>F8-3036</b>		
Engine Mounting	1.8 16V		<b>F8-3040</b>		H=116; D=111
Stabiliser Mounting	1.3, 1.3 CAT, 1.6, 1.6 D, 1.6 TD, 1.8, 1.8 16V, 1.8 CAT, 1.8 Syncro		<b>F8-3042</b>		H=33; d=17; W=35
Flange, carburettor	1.6, 1.8		<b>F8-3044</b>		H=21
Flange, carburettor	1.6		<b>F8-3045</b>		H=21
Flange, carburettor	1.6	01/1987 →	<b>F8-3047</b>		H=24
Flange, carburettor	1.6, 1.8		<b>F8-3047</b>		H=24
Flange, carburettor	1.8 CAT		<b>F8-3048</b>		H=27; d=40
Bracket, engine mounting	1.8 Syncro		<b>F8-3049</b>		
Clamp, silencer	1.3, 1.3 CAT, 1.6, 1.6 D, 1.6 TD, 1.8, 1.8 16V, 1.8 CAT		<b>F8-4027</b>		H=17; W=53, 61
Mounting, stabilizer coupling rod	1.3, 1.3 CAT, 1.6, 1.6 D, 1.6 TD, 1.8, 1.8 16V, 1.8 CAT, 1.8 Syncro	Coupling Rod	<b>F8-4060</b>		H=14; d=12; D=38
Rubber Buffer, suspension	1.3, 1.3 CAT, 1.6, 1.6 D, 1.6 TD, 1.8, 1.8 16V, 1.8 CAT, 1.8 Syncro		<b>F8-4063</b>		H=83; d1=18; d2=25; D1=48; D2=60
Protective Cap/Bellow, shock absorber	1.3, 1.3 CAT, 1.6, 1.6 D, 1.6 TD, 1.8, 1.8 16V, 1.8 CAT, 1.8 Syncro		<b>F8-4064</b>		H=90; d1=50; d2=71; D1=66; D2=77
Bellow, steering	1.3, 1.3 CAT, 1.6, 1.6 D, 1.6 TD, 1.8, 1.8 16V, 1.8 CAT, 1.8 Syncro		<b>F8-4069</b>		
Bellow, steering	1.3, 1.3 CAT, 1.6, 1.6 D, 1.6 TD, 1.8, 1.8 16V, 1.8 CAT, 1.8 Syncro		<b>F8-4075</b>		H=200; d=10; D=48
Bellow, steering	1.3 CAT, 1.6, 1.6 D, 1.6 TD, 1.8, 1.8 16V, 1.8 CAT	ch.1G-L-000001→; for steering manufacturer: ZF;	<b>F8-4076</b>		H=151; D1=20; D2=55
Bellow, steering	1.6 TD	for steering manufacturer: ZF;	<b>F8-4076</b>		H=151; D1=20; D2=55

<b>F8-1005</b>	<b>F8-1006</b>	<b>F8-1007</b>	<b>F8-1007S</b>	<b>F8-1008</b>	<b>F8-1009B</b>	<b>F8-1009C</b>
Ref.Nr.: 191199279E	Ref.Nr.: 191199402B	Ref.Nr.: 191407181A	Ref.Nr.: 191407181A	Ref.Nr.: 191407181E	Ref.Nr.: 176412329	Ref.Nr.: 357412329
<b>F8-1010</b>	<b>F8-1010S</b>	<b>F8-1025</b>	<b>F8-3036</b>	<b>F8-3040</b>	<b>F8-3042</b>	<b>F8-3044</b>
Ref.Nr.: 191501541	Ref.Nr.: 191501541	Ref.Nr.: 191199262C	Ref.Nr.: 377412335A	Ref.Nr.: 357199279	Ref.Nr.: 191411314	Ref.Nr.: 026129761A
<b>F8-3045</b>	<b>F8-3047</b>	<b>F8-3048</b>	<b>F8-3049</b>	<b>F8-4027</b>	<b>F8-4060</b>	<b>F8-4063</b>
Ref.Nr.: 027129761	Ref.Nr.: 050129761C	Ref.Nr.: 050129761B	Ref.Nr.: 191199273C	Ref.Nr.: 171253147A	Ref.Nr.: 191411329	Ref.Nr.: 191412303A

Article Description



Article Nr.

Fitting Position



**JETTA Mk II (19E, 1G2, 165)**

01/1984 → 07/1992

Bellow, driveshaft	1.3, 1.6, 1.8, 1.8 16V, 1.8 CAT, 1.8 Syncro		<b>F8-4080</b>		H=95; D1=29; D2=96
Mounting, steering gear	1.3, 1.3 CAT, 1.6, 1.6 D, 1.6 TD, 1.8, 1.8 16V, 1.8 CAT, 1.8 Syncro		<b>F8-5145</b>		d1=50.7; d2=48.3
Spring Cap	1.3, 1.3 CAT, 1.6, 1.6 D, 1.6 TD, 1.8, 1.8 16V, 1.8 CAT, 1.8 Syncro		<b>F8-5362</b>		
Spring Mounting	1.3, 1.3 CAT, 1.6, 1.6 D, 1.6 TD, 1.8, 1.8 16V, 1.8 CAT, 1.8 Syncro		<b>F8-5393</b>		
Stabiliser Mounting	1.3, 1.3 CAT, 1.6, 1.6 D, 1.6 TD, 1.8, 1.8 16V, 1.8 CAT, 1.8 Syncro	Stabi. Diam. [mm]= 21.5	<b>F8-5395</b>		d=19
Stabiliser Mounting	1.8	GX; Stabi. Diam. [mm]= 21.5	<b>F8-5395</b>		d=19
Stabiliser Mounting	1.8 CAT	RP; Stabi. Diam. [mm]= 21.5	<b>F8-5395</b>		d=19
Top Strut Mounting	1.3, 1.3 CAT, 1.6, 1.6 D, 1.6 TD, 1.8, 1.8 16V, 1.8 CAT, 1.8 Syncro		<b>F8-5402</b>		
Top Strut Mounting	1.3, 1.3 CAT, 1.6, 1.6 D, 1.6 TD, 1.8, 1.8 16V, 1.8 CAT, 1.8 Syncro		<b>F8-5403</b>		
Engine Mounting	1.3, 1.3 CAT, 1.6, 1.6 D, 1.6 TD, 1.8, 1.8 16V, 1.8 CAT, 1.8 Syncro		<b>F8-5554</b>		H=39.5; d1=16; d2=24; D=50
Rubber Buffer, suspension	1.3, 1.3 CAT, 1.6, 1.6 D, 1.6 TD, 1.8, 1.8 16V, 1.8 CAT		<b>F8-5594</b>		H=146; d=10.5; D=55.6
Rubber Buffer, suspension	1.8	GU	<b>F8-5594</b>		H=146; d=10.5; D=55.6
Rubber Buffer, suspension	1.8 CAT	RP	<b>F8-5594</b>		H=146; d=10.5; D=55.6
Rubber Buffer, suspension	1.8 Syncro	ch.→1G-L-085400;	<b>F8-5594</b>		H=146; d=10.5; D=55.6
Protective Cap/Bellow, shock absorber	1.3, 1.3 CAT, 1.6, 1.6 D, 1.6 TD, 1.8, 1.8 16V, 1.8 CAT		<b>F8-5747</b>		H=90
Protective Cap/Bellow, shock absorber	1.8	GU, GX	<b>F8-5747</b>		H=90
Protective Cap/Bellow, shock absorber	1.8 CAT	RP	<b>F8-5747</b>		H=90
Protective Cap/Bellow, shock absorber	1.8 Syncro	ch.→1G-L-085400;	<b>F8-5747</b>		H=90; Overall Height [mm]=20
Repair Kit, suspension strut	1.3, 1.3 CAT, 1.6, 1.6 D, 1.6 TD, 1.8, 1.8 16V, 1.8 CAT, 1.8 Syncro		<b>F8-6382</b>		
Sleeve, control arm mounting	All Models		<b>F8-6699</b>		d=16; L=50; D=17
Engine Mounting	1.3	ch.16-E-300001, 19-E-300001→	<b>F8-6922</b>		H=65
Engine Mounting	1.3 CAT		<b>F8-6922</b>		H=65
Bellow, driveshaft	1.3, 1.3 CAT, 1.6, 1.6 D, 1.6 TD, 1.8		<b>F8-7722</b>		d1=26; d2=78; L=110
Bellow, driveshaft	1.8	GU, GX	<b>F8-7722</b>		d1=26; d2=78; L=110
Bellow, driveshaft	1.8 CAT	RP	<b>F8-7722</b>		d1=26; d2=78; L=110
Control Arm-/Trailing Arm Bush	1.3, 1.3 CAT, 1.6, 1.6 D, 1.6 TD, 1.8, 1.8 16V, 1.8 CAT, 1.8 Syncro		<b>F8-7978</b>		
Control Arm-/Trailing Arm Bush	1.3, 1.3 CAT, 1.6, 1.6 D, 1.6 TD, 1.8, 1.8 16V, 1.8 CAT, 1.8 Syncro		<b>G9-648</b>		H=54; d=12; D1=33; D2=36

<b>F8-4080</b>	<b>F8-5145</b>	<b>F8-5362</b>	<b>F8-5393</b>	<b>F8-5395</b>	<b>F8-5402</b>	<b>F8-5403</b>
Ref.Nr.: 113501149	Ref.Nr.: 191419883	Ref.Nr.: 191512113	Ref.Nr.: 1H0512149	Ref.Nr.: 1H0411314	Ref.Nr.: 191512335	Ref.Nr.: 191512333
<b>F8-5554</b>	<b>F8-5594</b>	<b>F8-5747</b>	<b>F8-6382</b>	<b>F8-6699</b>	<b>F8-6922</b>	<b>F8-7722</b>
Ref.Nr.: 191199233	Ref.Nr.: 191512131B	Ref.Nr.: 191513425	Ref.Nr.: 191512333S	Ref.Nr.: 191407190A	Ref.Nr.: 191199381A	Ref.Nr.: 191407285F
<b>F8-7978</b>	<b>G9-648</b>	<b>LM-10003S</b>				
Ref.Nr.: 357407182F	Ref.Nr.: 357407182	Ref.Nr.: 357422831A				



**Article Description****Article Nr.****Fitting Position****JETTA Mk II (19E, 1G2, 165) 01/1984 → 07/1992**

Bellow, steering	All Models	for steering gear manufacturer: TRW; with clamps;	<b>LM-10003S</b>		d1=9; d2=43; L [mm]=210
Bellow, steering	All Models	with clamps	<b>LM-10006S</b>		d1=10; d2=41; L [mm]=210
Bellow, steering	All Models	with clamps;	<b>LM-10024S</b>		d1=25; d2=41; L [mm]=120
Bellow, steering	1.3 CAT, 1.6, 1.6 D, 1.6 TD, 1.8, 1.8 16V, 1.8 CAT	ch.1G-L-000001→; Manufacturer Restriction: ZF; with clamps;	<b>LM-10029S</b>		d1=13; d2=45; L [mm]=138
Bellow, steering	1.6 TD	Manufacturer Restriction: ZF; with clamps;	<b>LM-10029S</b>		d1=13; d2=45; L [mm]=138
Bellow, steering	All Models	with clamps;	<b>LM-10050S</b>		d1=25; d2=39; L [mm]=126
Bellow, driveshaft	1.3, 1.3 CAT, 1.6, 1.6 D, 1.6 TD, 1.8, 1.8 CAT, 1.8 Syncro		<b>M-830220</b>		
Bellow Set, drive shaft	1.3, 1.3 CAT, 1.6, 1.6 D, 1.6 TD, 1.8, 1.8 Syncro		<b>MK-830220</b>		
Bellow Set, drive shaft	1.3, 1.3 CAT, 1.6, 1.6 D, 1.6 TD, 1.8, 1.8 Syncro		<b>MK-830220</b>		
Bellow Set, drive shaft	1.8	GU, GX	<b>MK-830220</b>		
Bellow Set, drive shaft	1.8 CAT	RP	<b>MK-830220</b>		
Bellow Set, drive shaft	1.3, 1.6 TD, 1.8		<b>MK-830220S</b>		

**JETTA III (1K2) 08/2005 → 10/2010**

Dust Cover Kit, shock absorber	1.4 TSI, 1.6, 1.6 FSI, 1.6 MultiFuel, 1.6 TDI, 1.9 TDI, 2.0 FSI, 2.0 TDI, 2.0 TDI 16V, 2.0 TFSI, 2.5 FSI	ch.1K-7-027309→;	<b>AK-735095</b>		
Dust Cover Kit, shock absorber	1.4 TSI, 1.6, 1.6 FSI, 1.9 TDI, 2.0 FSI, 2.0 TDI, 2.0 TDI 16V, 2.0 TFSI		<b>AK-735184</b>		
Alternator Freewheel Clutch	1.6, 1.6 MultiFuel, 1.6 TDI, 2.0 FSI, 2.0 TDI, 2.0 TDI 16V, 2.0 TFSI		<b>F5-1004</b>		
Alternator Freewheel Clutch	1.4 TSI		<b>F5-1064</b>		
Alternator Freewheel Clutch	2.5 FSI		<b>F5-1076</b>		
Control Arm-/Trailing Arm Bush	1.4 TSI, 1.6, 1.6 FSI, 1.6 MultiFuel, 1.6 TDI, 1.9 TDI, 2.0 FSI, 2.0 TDI, 2.0 TDI 16V, 2.0 TFSI, 2.5 FSI		<b>F8-5633</b>		
Belt Pulley, crankshaft	2.0 FSI, 2.0 TFSI		<b>F8-5650</b>		
Top Strut Mounting	1.4 TSI, 1.6, 1.6 FSI, 1.6 MultiFuel, 1.6 TDI, 1.9 TDI, 2.0 FSI, 2.0 TDI, 2.0 TDI 16V, 2.0 TFSI, 2.5 FSI		<b>F8-6284</b>		
Top Strut Mounting	1.4 TSI, 1.6, 1.6 FSI, 1.9 TDI, 2.0 FSI, 2.0 TDI, 2.0 TDI 16V, 2.0 TFSI, 2.5 FSI	ch.1K-7-027309→	<b>F8-6348</b>		
Top Strut Mounting	1.4 TSI, 1.6, 1.6 FSI, 1.9 TDI, 2.0 FSI, 2.0 TDI, 2.0 TDI 16V, 2.0 TFSI, 2.5 FSI	ch.→1K-7-027308	<b>F8-6349</b>		
Belt Pulley, crankshaft	1.9 TDI, 2.0 TDI, 2.0 TDI 16V	Number of Ribs: 5; Parameter: 6PK	<b>F8-6396</b>		H=41.6; d=30; Mounting points diam.[mm]=7, 8.6; D=139.7
Control Arm-/Trailing Arm Bush	1.4 TSI, 1.6, 1.6 FSI, 1.6 TDI, 1.9 TDI, 2.0 FSI, 2.0 TDI, 2.0 TDI 16V, 2.0 TFSI, 2.5 FSI	Aluminium	<b>F8-6424</b>		
Control Arm-/Trailing Arm Bush	1.4 TSI, 1.6, 1.6 FSI, 1.6 TDI, 1.9 TDI, 2.0 FSI, 2.0 TDI, 2.0 TDI 16V, 2.0 TFSI, 2.5 FSI	Aluminium	<b>F8-6425</b>		

<b>AK-735095</b>	<b>AK-735184</b>	<b>F5-1004</b>	<b>F5-1064</b>	<b>F5-1076</b>	<b>F8-5633</b>	<b>F8-5650</b>
Ref.Nr.: 1J0512131B	Ref.Nr.: 3C0412303A	Ref.Nr.: 038903119T	Ref.Nr.: 03C903119D	Ref.Nr.: 07K903119C	Ref.Nr.: 1K0407182A	Ref.Nr.: 06A105243E
<b>F8-6284</b>	<b>F8-6348</b>	<b>F8-6349</b>	<b>F8-6396</b>	<b>F8-6424</b>	<b>F8-6425</b>	<b>F8-6463</b>
Ref.Nr.: 6N0412249C	Ref.Nr.: 1K0513353G	Ref.Nr.: 1K0513353H	Ref.Nr.: 03G105243	Ref.Nr.: 1K0199232G	Ref.Nr.: 1K0199231J	Ref.Nr.: 1K0505541B
<b>LM-10003S</b>	<b>LM-10006S</b>	<b>LM-10024S</b>	<b>LM-10029S</b>	<b>LM-10050S</b>	<b>M-830220</b>	<b>MK-830220</b>
Ref.Nr.: 357422831A	Ref.Nr.: 1H0422831B	Ref.Nr.: 171419831B	Ref.Nr.: 1H0422831A	Ref.Nr.: 171419831C	Ref.Nr.: 191498203C	Ref.Nr.: 171498203

Article Description



Article Nr.

Fitting Position



## JETTA III (1K2)

08/2005 → 10/2010

Control Arm-/Trailing Arm Bush	1.4 TSI, 1.6, 1.6 FSI, 1.9 TDI, 2.0 FSI, 2.0 TDI, 2.0 TDI 16V, 2.0 TFSI, 2.5 FSI		<b>F8-6463</b>		H=64; d=12; D=60
Engine Mounting	2.0 TDI	AZV	<b>F8-6528</b>		
Engine Mounting	2.0 TDI, 2.0 TDI 16V		<b>F8-6528</b>		
Engine Mounting	1.6 FSI		<b>F8-6531</b>		H=117.7; L=165; W=149
Anti-Friction Bearing	1.4 TSI, 1.6, 1.6 FSI, 1.6 MultiFuel, 1.6 TDI, 1.9 TDI, 2.0 FSI, 2.0 TDI, 2.0 TDI 16V, 2.0 TFSI, 2.5 FSI		<b>F8-6569</b>		
Top Strut Mounting	1.4 TSI, 1.6, 1.6 FSI, 1.6 MultiFuel, 1.6 TDI, 1.9 TDI, 2.0 FSI, 2.0 TDI, 2.0 TDI 16V, 2.0 TFSI, 2.5 FSI		<b>F8-6570</b>		
Belt Pulley, crankshaft	1.6 TDI	Number of Ribs: 5; Parameter: 6PK	<b>F8-6572</b>		
Engine Mounting	1.6		<b>F8-6988</b>		
Engine Mounting	2.0 FSI		<b>F8-6989</b>		
Engine Mounting	2.0 TFSI	BPY, BWA	<b>F8-6989</b>		
Rubber Buffer, suspension	1.4 TSI, 1.6, 1.6 FSI, 1.6 MultiFuel, 1.6 TDI, 1.9 TDI, 2.0 FSI, 2.0 TDI, 2.0 TDI 16V, 2.0 TFSI, 2.5 FSI	for OE: 2UA, 2UC, G56, G57;	<b>F8-7131</b>		H=70
Protective Cap/Bellow, shock absorber	1.4 TSI, 1.6, 1.6 FSI, 1.6 MultiFuel, 1.6 TDI, 1.9 TDI, 2.0 FSI, 2.0 TDI, 2.0 TDI 16V, 2.0 TFSI, 2.5 FSI		<b>F8-7132</b>		H=190
Rubber Buffer, suspension	1.4 TSI, 1.6, 1.6 FSI, 1.6 MultiFuel, 1.6 TDI, 1.9 TDI, 2.0 FSI, 2.0 TDI, 2.0 TDI 16V, 2.0 TFSI, 2.5 FSI	; for OE: 1JA, 1JB, 1JJ;	<b>F8-7140</b>		H=133
Rubber Buffer, suspension	1.4 TSI, 1.6, 1.6 FSI, 1.6 TDI, 1.9 TDI, 2.0 FSI, 2.0 TDI, 2.0 TDI 16V, 2.0 TFSI, 2.5 FSI	ch.1K-8-000001-→;	<b>F8-7576</b>		H=133
Rubber Buffer, suspension	1.4 TSI, 1.6, 1.6 FSI, 1.9 TDI, 2.0 FSI, 2.0 TDI, 2.0 TDI 16V, 2.0 TFSI, 2.5 FSI	ch.→1K-7-299-000;	<b>F8-7600</b>		H=133
Rubber Buffer, suspension	1.4 TSI, 1.6, 1.6 FSI, 1.6 MultiFuel, 1.6 TDI, 1.9 TDI, 2.0 FSI, 2.0 TDI, 2.0 TDI 16V, 2.0 TFSI, 2.5 FSI	ch.1K-8-020817-→; Shape Round;	<b>F8-7601</b>		H=118
Protective Cap/Bellow, shock absorber	1.4 TSI, 1.6, 1.6 FSI, 1.6 MultiFuel, 1.6 TDI, 1.9 TDI, 2.0 FSI, 2.0 TDI, 2.0 TDI 16V, 2.0 TFSI, 2.5 FSI	Shape Round	<b>F8-7640</b>		H=176
Rubber Buffer, suspension	1.4 TSI, 1.6, 1.6 FSI, 1.6 MultiFuel, 1.6 TDI, 1.9 TDI, 2.0 FSI, 2.0 TDI, 2.0 TDI 16V, 2.0 TFSI, 2.5 FSI	for OE: 2UC, G57, G68;	<b>F8-7697</b>		H=55
Rubber Buffer, suspension	1.4 TSI, 1.6, 1.6 FSI, 1.6 MultiFuel, 1.6 TDI, 1.9 TDI, 2.0 FSI, 2.0 TDI, 2.0 TDI 16V, 2.0 TFSI, 2.5 FSI	for OE: 2UB, G56;	<b>F8-7703</b>		H=90; d=25
Rubber Buffer, suspension	1.4 TSI, 1.6, 1.6 FSI, 1.6 MultiFuel, 1.6 TDI, 1.9 TDI, 2.0 FSI, 2.0 TDI, 2.0 TDI 16V, 2.0 TFSI, 2.5 FSI		<b>F8-7714</b>		H=118
Rubber Buffer, suspension	1.4 TSI, 1.6, 1.6 FSI, 1.6 MultiFuel, 1.6 TDI, 1.9 TDI, 2.0 FSI, 2.0 TDI, 2.0 TDI 16V, 2.0 TFSI, 2.5 FSI	for OE: 2UC, G56, G67	<b>F8-7809</b>		H=55
Rubber Buffer, suspension	All Models		<b>F8-7834</b>		H=90
Belt Pulley, crankshaft	2.0 TFSI	Number of Ribs: 5; Parameter: 6PK	<b>F8-7880</b>		D=143
Rubber Buffer, suspension	1.4 TSI, 1.6, 1.6 FSI, 1.6 MultiFuel, 1.9 TDI, 2.0 FSI, 2.0 TDI, 2.0 TDI 16V, 2.0 TFSI, 2.5 FSI	ch.→1K-8-020 816; Shape Oval;	<b>F8-7897</b>		H=118
Control Arm-/Trailing Arm Bush	1.4 TSI, 1.6, 1.6 FSI, 1.6 MultiFuel, 1.6 TDI, 1.9 TDI, 2.0 FSI, 2.0 TDI, 2.0 TDI 16V, 2.0 TFSI, 2.5 FSI		<b>F8-7902</b>		H=60; d=12; D=42
Control Arm-/Trailing Arm Bush	1.4 TSI, 1.6, 1.6 FSI, 1.6 MultiFuel, 1.6 TDI, 1.9 TDI, 2.0 FSI, 2.0 TDI, 2.0 TDI 16V, 2.0 TFSI, 2.5 FSI		<b>F8-7907</b>		H=45; d=14; D=38

<b>F8-6463</b>	<b>F8-6528</b>	<b>F8-6531</b>	<b>F8-6569</b>	<b>F8-6570</b>	<b>F8-6572</b>	<b>F8-6988</b>
Ref.Nr.: 1K0505541B	Ref.Nr.: 1K0 199 262 AT	Ref.Nr.: 1K0199262T	Ref.Nr.: 6N0412249C	Ref.Nr.: 1K0412331C	Ref.Nr.: 038105243L	Ref.Nr.: 1K0199262AL
<b>F8-6989</b>	<b>F8-7131</b>	<b>F8-7132</b>	<b>F8-7140</b>	<b>F8-7576</b>	<b>F8-7600</b>	<b>F8-7601</b>
Ref.Nr.: 1K0199262AM	Ref.Nr.: 1K0412303B	Ref.Nr.: 6N0413175A	Ref.Nr.: 3C0511359	Ref.Nr.: 1K0 511 353 M	Ref.Nr.: 1K0 511 353 P	Ref.Nr.: 1K0511353N
<b>F8-7640</b>	<b>F8-7697</b>	<b>F8-7703</b>	<b>F8-7714</b>	<b>F8-7809</b>	<b>F8-7834</b>	<b>F8-7880</b>
Ref.Nr.: 1K0513425A	Ref.Nr.: 1K0412303F	Ref.Nr.: 1K0412303G	Ref.Nr.: 3C0511359B	Ref.Nr.: 1K0412303E	Ref.Nr.: 1K0412303H	Ref.Nr.: 06H105243F

**Article Description****Article Nr.****Fitting Position****JETTA III (1K2) 08/2005 → 10/2010**

Control Arm-/Trailing Arm Bush	1.4 TSI, 1.6, 1.6 FSI, 1.6 MultiFuel, 1.6 TDI, 1.9 TDI, 2.0 FSI, 2.0 TDI, 2.0 TDI 16V, 2.0 TFSI, 2.5 FSI		<b>F8-7908</b>		H=45; d=12; D=38
Engine Mounting	1.9 TDI		<b>F8-7958</b>		
Engine Mounting	1.4 TSI		<b>F8-7959</b>		
Engine Mounting	1.4 TSI	ch.1K-8-000 001→	<b>F8-7959</b>		
Engine Mounting	1.4 TSI, 1.6 MultiFuel		<b>F8-7960</b>		
Engine Mounting	1.6, 1.6 FSI		<b>F8-7960</b>		
Engine Mounting	1.6	BSE, BSF;  6-speed	<b>F8-7961</b>		
Engine Mounting	1.6 FSI, 2.0 FSI	6-speed	<b>F8-7961</b>		
Engine Mounting	1.9 TDI	6-speed	<b>F8-7961</b>		
Engine Mounting	2.5 FSI	5-speed	<b>F8-7961</b>		
Engine Mounting	1.9 TDI, 2.0 TDI, 2.0 TDI 16V	6-speed	<b>F8-7962</b>		
Engine Mounting	2.0 TFSI	BWA;  6-speed	<b>F8-7962</b>		
Engine Mounting	1.4 TSI, 1.6, 1.6 FSI		<b>F8-7965</b>		
Engine Mounting	1.4 TSI		<b>F8-7981</b>		
Engine Mounting	1.4 TSI, 1.9 TDI, 2.0 TDI, 2.0 TDI 16V	ch.→1K-8-116824	<b>F8-7981</b>		
Engine Mounting	2.0 FSI		<b>F8-7981</b>		
Engine Mounting	2.0 TFSI	ch.→1K-8-116824;  BPY, BWA	<b>F8-7981</b>		
Engine Mounting	1.4 TSI, 1.6 FSI, 1.6 MultiFuel, 1.6 TDI, 1.9 TDI, 2.0 TDI		<b>F8-7982</b>		
Engine Mounting	1.6	BSE, BSF, CCSA	<b>F8-7982</b>		
Engine Mounting	2.0 FSI	BLR, BLY, BVY, BVZ	<b>F8-7982</b>		
Engine Mounting	2.0 TDI	CEGA	<b>F8-7982</b>		
Engine Mounting	2.0 TDI 16V	BKD, CBDB	<b>F8-7982</b>		
Engine Mounting	2.0 TFSI	BPY, BWA	<b>F8-7982</b>		
Engine Mounting	2.5 FSI	BGP, BTK	<b>F8-7982</b>		
Engine Mounting	2.5 FSI	CCCA	<b>F8-7982</b>		
Engine Mounting	1.6 TDI	4 Motion	<b>F8-8152</b>		
Engine Mounting	2.0 TDI		<b>F8-8152</b>		
Engine Mounting	2.0 TDI, 2.0 TDI 16V	6-speed	<b>F8-8152</b>		

**JETTA IV (162, 163) 04/2010 → 07/2014**

Dust Cover Kit, shock absorber	1.2 TSI, 1.4 TSI, 1.4 TSI Hybrid, 1.6, 1.6 TDI, 2.0, 2.0 TDI, 2.0 TSI, 2.5 FSI	<b>ST</b>	<b>AK-735095</b>		
Alternator Freewheel Clutch	1.4 TSI, 1.6 TDI, 2.0, 2.0 TDI, 2.0 TSI		<b>F5-1004</b>		
Alternator Freewheel Clutch	1.4 TSI, 2.0 TSI		<b>F5-1044</b>		
Alternator Freewheel Clutch	1.2 TSI, 1.4 TSI, 1.6		<b>F5-1064</b>		

<b>AK-735095</b>	<b>F5-1004</b>	<b>F5-1044</b>	<b>F5-1064</b>	<b>F5-1076</b>	<b>F8-7908</b>	<b>F8-7958</b>
Ref.Nr.: 1J0512131B	Ref.Nr.: 038903119T	Ref.Nr.: 06B903119B	Ref.Nr.: 03C903119D	Ref.Nr.: 07K903119C	Ref.Nr.: 1K0505279A	Ref.Nr.: 1K0199262AS
<b>F8-7959</b>	<b>F8-7960</b>	<b>F8-7961</b>	<b>F8-7962</b>	<b>F8-7965</b>	<b>F8-7981</b>	<b>F8-7982</b>
Ref.Nr.: 1K0199262CG	Ref.Nr.: 1K0199555L	Ref.Nr.: 1K0199555N	Ref.Nr.: 1K0199555Q	Ref.Nr.: 1K0199855BA	Ref.Nr.: 1K0199867Q	Ref.Nr.: 1K0199868Q
<b>F8-8152</b>						
Ref.Nr.: 1K0199555T						

Article Description



Article Nr.

Fitting Position



**JETTA IV (162, 163)**

04/2010 → 07/2014

Alternator Freewheel Clutch	2.5 FSI		<b>F5-1076</b>		
Control Arm-/Trailing Arm Bush	1.2 TSI, 1.4 TSI, 1.6 TDI, 2.0, 2.0 TDI, 2.0 TSI, 2.5 FSI		<b>F8-5633</b>		
Rubber Buffer, suspension	1.2 TSI	for OE: G12; <b>SP</b>	<b>F8-6041</b>		H=53
Top Strut Mounting	1.2 TSI, 1.4 TSI, 1.4 TSI Hybrid, 1.6, 1.6 TDI, 2.0, 2.0 TDI, 2.0 TSI, 2.5 FSI		<b>F8-6284</b>		
Top Strut Mounting	1.2 TSI, 1.4 TSI, 1.4 TSI Hybrid, 1.6, 1.6 TDI, 2.0, 2.0 TDI, 2.0 TSI, 2.5 FSI	for OE: 1JA, 1JD, 1JL, 1JN; <b>ST</b>	<b>F8-6348</b>		
Top Strut Mounting	1.2 TSI, 1.4 TSI, 1.4 TSI Hybrid, 1.6, 1.6 TDI, 2.0, 2.0 TDI, 2.0 TSI, 2.5 FSI	for OE: 1JC, 1JE, 1JF, 1JK, 1JS, UB2; <b>SP</b>	<b>F8-6348</b>		
Anti-Friction Bearing	1.2 TSI, 1.4 TSI, 1.4 TSI Hybrid, 1.6, 1.6 TDI, 2.0, 2.0 TDI, 2.0 TSI, 2.5 FSI		<b>F8-6569</b>		
Top Strut Mounting	1.2 TSI, 1.4 TSI, 1.4 TSI Hybrid, 1.6, 1.6 TDI, 2.0, 2.0 TDI, 2.0 TSI, 2.5 FSI		<b>F8-6570</b>		
Belt Pulley, crankshaft	1.6 TDI, 2.0 TDI	Number of Ribs: 5; Parameter: 6PK	<b>F8-6572</b>		
Belt Pulley, crankshaft	2.0 TDI	CFFB, CFHC, CLCB; Number of Ribs: 5; Parameter: 6PK	<b>F8-6572</b>		
Rubber Buffer, suspension	1.2 TSI, 1.4 TSI, 1.6, 1.6 TDI, 2.0, 2.0 TDI, 2.0 TSI, 2.5 FSI	for OE: 2UA, 2UC, 2UD, G14, G30	<b>F8-7131</b>		H=70
Protective Cap/Bellow, shock absorber	1.2 TSI, 1.4 TSI, 1.6 TDI, 2.0, 2.0 TDI, 2.5 FSI		<b>F8-7132</b>		H=190
Rubber Buffer, suspension	1.2 TSI, 1.4 TSI, 1.6, 1.6 TDI, 2.0, 2.0 TDI, 2.0 TSI, 2.5 FSI	for OE: 0N4	<b>F8-7140</b>		H=133
Rubber Buffer, suspension	1.2 TSI, 1.4 TSI, 1.4 TSI Hybrid, 1.6, 1.6 TDI, 2.0, 2.0 TDI, 2.0 TSI, 2.5 FSI	for OE: 0N4; <b>SP</b>	<b>F8-7576</b>		H=133
Rubber Buffer, suspension	1.2 TSI, 1.4 TSI, 1.4 TSI Hybrid, 1.6, 1.6 TDI, 2.0, 2.0 TDI, 2.0 TSI, 2.5 FSI	for OE: 0N4; Shape Round	<b>F8-7601</b>		H=118
Top Strut Mounting	1.2 TSI, 1.4 TSI, 1.4 TSI Hybrid, 1.6, 1.6 TDI, 2.0, 2.0 TDI, 2.0 TSI, 2.5 FSI	for OE: 1JB; <b>Δ</b>	<b>F8-7603</b>		
Top Strut Mounting	1.2 TSI, 1.4 TSI, 1.4 TSI Hybrid, 1.6, 1.6 TDI, 2.0, 2.0 TDI, 2.0 TSI, 2.5 FSI	for OE: 1JJ; <b>ST</b>	<b>F8-7603</b>		
Top Strut Mounting	1.2 TSI, 1.4 TSI, 1.4 TSI Hybrid, 1.6, 1.6 TDI, 2.0, 2.0 TDI, 2.0 TSI, 2.5 FSI	for OE: 1JT; <b>SP</b>	<b>F8-7603</b>		
Protective Cap/Bellow, shock absorber	1.2 TSI, 1.4 TSI, 1.4 TSI Hybrid, 1.6 TDI, 2.0, 2.0 TDI, 2.0 TSI, 2.5 FSI	Shape Round	<b>F8-7640</b>		H=176
Rubber Buffer, suspension	1.2 TSI, 1.4 TSI, 1.6 TDI, 2.0, 2.0 TDI, 2.0 TSI, 2.5 FSI	for OE: 2UC, G18, G24, G57; <b>SP</b>	<b>F8-7697</b>		H=55
Rubber Buffer, suspension	1.2 TSI, 1.4 TSI, 1.6 TDI, 2.0, 2.0 TDI, 2.0 TSI, 2.5 FSI	for OE: 2UB, G47, G56; <b>Δ</b>	<b>F8-7703</b>		H=90; d=25
Rubber Buffer, suspension	1.2 TSI, 1.4 TSI, 1.6 TDI, 2.0, 2.0 TDI, 2.0 TSI, 2.5 FSI	for OE: 2UC, G47, G56	<b>F8-7809</b>		H=55
Rubber Buffer, suspension	1.2 TSI, 1.4 TSI, 1.4 TSI Hybrid, 1.6, 1.6 TDI, 2.0, 2.0 TDI, 2.0 TSI, 2.5 FSI		<b>F8-7834</b>		H=90
Rubber Buffer, suspension	1.2 TSI, 1.4 TSI, 1.6, 1.6 TDI, 2.0, 2.0 TDI, 2.0 TSI, 2.5 FSI		<b>F8-7836</b>		H=143
Control Arm-/Trailing Arm Bush	1.2 TSI, 1.4 TSI, 1.4 TSI Hybrid, 1.6, 1.6 TDI, 2.0, 2.0 TDI, 2.0 TSI, 2.5 FSI		<b>F8-7856</b>		H=50; d=13.2; D=65

<b>F5-1076</b>	<b>F8-5633</b>	<b>F8-6041</b>	<b>F8-6284</b>	<b>F8-6348</b>	<b>F8-6569</b>	<b>F8-6570</b>
Ref.Nr.: 07K903119C	Ref.Nr.: 1K0407182A	Ref.Nr.: 1J0412303	Ref.Nr.: 6N0412249C	Ref.Nr.: 1K0513353G	Ref.Nr.: 6N0412249C	Ref.Nr.: 1K0412331C
<b>F8-6572</b>	<b>F8-7131</b>	<b>F8-7132</b>	<b>F8-7140</b>	<b>F8-7576</b>	<b>F8-7601</b>	<b>F8-7603</b>
Ref.Nr.: 038105243L	Ref.Nr.: 1K0412303B	Ref.Nr.: 6N0413175A	Ref.Nr.: 3C0511359	Ref.Nr.: 1K0 511 353 M	Ref.Nr.: 1K0511353N	Ref.Nr.: 3C0513353
<b>F8-7640</b>	<b>F8-7697</b>	<b>F8-7703</b>	<b>F8-7809</b>	<b>F8-7834</b>	<b>F8-7836</b>	<b>F8-7856</b>
Ref.Nr.: 1K0513425A	Ref.Nr.: 1K0412303F	Ref.Nr.: 1K0412303G	Ref.Nr.: 1K0412303E	Ref.Nr.: 1K0412303H	Ref.Nr.: 1T0511359	Ref.Nr.: 5C0407183A

**Article Description****Article Nr.****Fitting Position**

<b>JETTA IV (162, 163)</b>				<b>04/2010 → 07/2014</b>	
Belt Pulley, crankshaft	2.0 TSI	Number of Ribs: 5; Parameter: 6PK	<b>F8-7880</b>		D=143
Engine Mounting	1.4 TSI		<b>F8-7960</b>	⊕	
Engine Mounting	2.0	CBPA	<b>F8-7960</b>	⊕	
Engine Mounting	2.0 TDI		<b>F8-8152</b>	⊕	
Engine Mounting	2.0 TDI	CFHC, CLCB	<b>F8-8152</b>	⊕	
Engine Mounting	2.0 TDI	CJAA;  6-speed	<b>F8-8152</b>	⊕	
<b>NEW BEETLE (9C1, 1C1)</b>				<b>01/1998 → 09/2010</b>	
Dust Cover Kit, shock absorber	1.9 TDI, 2.0		<b>AK-735039</b>	⊕ ⊕ ⊕	
Dust Cover Kit, shock absorber	1.4, 1.6, 1.8 T, 1.9 TDI, 2.0, 2.3 V5, RSI 3.2 4motion		<b>AK-735095</b>	⊕ ⊕ ⊕	
Dust Cover Kit, shock absorber	All Models	<b>ST</b>	<b>AK-735410</b>	⊕ ⊕ ⊕	H=210
Alternator Freewheel Clutch	1.6, 1.8 T, 1.9 TDI, 2.3 V5, RSI 3.2 4motion		<b>F5-1004</b>		
Alternator Freewheel Clutch	1.9 TDI		<b>F5-1009</b>		
Alternator Freewheel Clutch	2.5		<b>F5-1076</b>		
Anti-Friction Bearing	All Models		<b>F8-3039</b>	⊕ ⊕ ⊕	H=14; d1=14; D=45
Top Strut Mounting	All Models		<b>F8-4067</b>	⊕ ⊕ ⊕	H=53; d=26; D=82
Bellow Set, steering	1.6, 1.8 T, 1.9 TDI, 2.0, RSI 3.2 4motion	for OE: 1J0422831	<b>F8-4074</b>	⊕ ⊕ ⊕	H=125; D1=34; D2=39
Stabiliser Mounting	1.4	BCA; only in connection with: F8-6579; Stabi. Diam. [mm]= 19	<b>F8-5215</b>		d=17
Stabiliser Mounting	1.6, 1.8 T, 1.9 TDI, 2.3 V5, RSI 3.2 4motion	only in connection with: F8-6579; Stabi. Diam. [mm]= 19	<b>F8-5215</b>		d=17
Stabiliser Mounting	2.0	AEG, AQY, AZG; only in connection with: F8-6579; Stabi. Diam. [mm]= 19	<b>F8-5215</b>		d=17
Stabiliser Mounting	1.8 T, 1.9 TDI, 2.0	ch.1C-X-499000, 9C-X-499000→; only in connection with: F8-6579; Stabi. Diam. [mm]= 23;	<b>F8-5220</b>		d=21
Stabiliser Mounting	1.6, 1.8 T, 1.9 TDI, 2.0, 2.3 V5	ch.→1C-X-499000, 9C-X-499000; only in connection with: F8-6579; Stabi. Diam. [mm]= 21	<b>F8-5221</b>	⊕ ⊕ ⊕	d=19; D=20.7
Top Strut Mounting	1.6, 1.8 T, 1.9 TDI, 2.0, 2.3 V5	ch.→1C-1-405000, 9C-1-603000	<b>F8-5380</b>	⊕ ⊕ ⊕	
Rubber Buffer, suspension	1.4, 1.6, 1.8 T, 1.9 TDI, 2.0, 2.3 V5		<b>F8-5381</b>	⊕ ⊕ ⊕ ↑	H=37; D=76
Stabiliser Mounting	1.4, 1.6, 1.8 T, 1.9 TDI, 2.0, 2.3 V5, RSI 3.2 4motion		<b>F8-5382</b>	⊕ ⊕ ⊕	D=14
Engine Mounting	1.6	BFS	<b>F8-5384</b>	⊕	
Mounting, manual transmission	1.6		<b>F8-5385</b>	⊕	
Mounting, manual transmission	1.6	AYD	<b>F8-5385</b>	⊕	
Engine Mounting	1.8 T, 1.9 TDI, 2.0		<b>F8-5386</b>		
Mounting, automatic transmission	1.4	BCA	<b>F8-5387</b>	⊕	
Mounting, automatic transmission	1.6	AYD	<b>F8-5387</b>	⊕	

<b>AK-735039</b>	<b>AK-735095</b>	<b>AK-735410</b>	<b>F5-1004</b>	<b>F5-1009</b>	<b>F5-1076</b>	<b>F8-3039</b>
Ref.Nr.: 357413175A	Ref.Nr.: 1J0512131B	Ref.Nr.: 1J0412303	Ref.Nr.: 038903119T	Ref.Nr.: 038903119	Ref.Nr.: 07K903119C	Ref.Nr.: 357412249A
<b>F8-4067</b>	<b>F8-4074</b>	<b>F8-5215</b>	<b>F8-5220</b>	<b>F8-5221</b>	<b>F8-5380</b>	<b>F8-5381</b>
Ref.Nr.: 1J0412331B	Ref.Nr.: 171419832A	Ref.Nr.: 1J0411314B	Ref.Nr.: 1J0411314G	Ref.Nr.: 1J0411314R	Ref.Nr.: 1J0513353G	Ref.Nr.: 1J0512149B
<b>F8-5382</b>	<b>F8-5384</b>	<b>F8-5385</b>	<b>F8-5386</b>	<b>F8-5387</b>	<b>F8-7880</b>	<b>F8-7960</b>
Ref.Nr.: 1J0411327	Ref.Nr.: 1J0199555AL	Ref.Nr.: 1J0199555AK	Ref.Nr.: 1J0199555AJ	Ref.Nr.: 1J0199555AH	Ref.Nr.: 06H105243F	Ref.Nr.: 1K0199555L

Article Description



Article Nr.

Fitting Position



**NEW BEETLE (9C1, 1C1)**

01/1998 → 09/2010

Mounting, automatic transmission	1.6, 1.9 TDI, 2.3 V5		<b>F8-5387</b>	⊕	
Mounting, automatic transmission	1.8 T	AWW	<b>F8-5387</b>	⊕	
Mounting, automatic transmission	1.9 TDI	ATD	<b>F8-5387</b>	⊕	
Mounting, automatic transmission	2.0	AEG	<b>F8-5387</b>	⊕	
Engine Mounting	1.4	5-speed	<b>F8-5388</b>	⊕ ⊕	
Engine Mounting	1.6		<b>F8-5390</b>	⊕	
Engine Mounting	1.8 T, 1.9 TDI, 2.0		<b>F8-5404</b>	⊕ ⊕	
Spring Cap	All Models		<b>F8-5580</b>	⊕ ⊕ ⊕ ↑	D=92
Belt Pulley, crankshaft	1.8 T, 2.0		<b>F8-5650</b>		
Protective Cap/Bellow, shock absorber	All Models		<b>F8-5683</b>	⊕ ⊕	H=210
Mounting, axle beam	1.4, 1.6, 1.8 T, 1.9 TDI, 2.0, 2.3 V5, 2.5		<b>F8-5907</b>	⊕ ⊕ ⊕	H=31; d1=18; d2=19; D1=65; D2=56
Rubber Buffer, suspension	1.4, 1.6, 1.8 T, 1.9 TDI, 2.0, 2.3 V5, 2.5	for OE: G18, G59	<b>F8-5996</b>	⊕ ⊕ ⊕	H=63
Rubber Buffer, suspension	1.4, 1.6, 1.8 T, 1.9 TDI, 2.0, 2.3 V5, 2.5	for OE: G50, G54;   ST	<b>F8-5996</b>	⊕ ⊕ ⊕	H=63
Rubber Buffer, suspension	1.4, 1.6, 1.8 T, 1.9 TDI, 2.0, 2.3 V5, 2.5	for OE: G74; for vehicles with sports package	<b>F8-5996</b>	⊕ ⊕ ⊕	H=63
Rubber Buffer, suspension	1.6, 1.8 T, 1.9 TDI, 2.0, 2.3 V5	SP	<b>F8-6007</b>	⊕ ⊕ ⊕	H=116
Rubber Buffer, suspension	1.4, 1.6, 1.8 T, 1.9 TDI, 2.0, 2.3 V5, RSI 3.2 4motion	Δ	<b>F8-6012</b>	⊕ ⊕ ⊕	H=143
Rubber Buffer, suspension	1.8 T, 2.0		<b>F8-6013</b>	⊕ ⊕ ⊕	H=128
Top Strut Mounting	1.4, 1.8 T, 1.9 TDI, 2.5		<b>F8-6040</b>	⊕ ⊕ ⊕	
Top Strut Mounting	1.6, 1.8 T, 1.9 TDI, 2.0, 2.3 V5	ch.1C-1-405001, 9C-1-603001→	<b>F8-6040</b>	⊕ ⊕ ⊕	
Rubber Buffer, suspension	1.4, 1.6, 1.8 T, 1.9 TDI, 2.0, 2.3 V5, 2.5	for OE: G16, G49;  ST	<b>F8-6041</b>	⊕ ⊕ ⊕	H=53
Rubber Buffer, suspension	1.4, 1.6, 1.8 T, 1.9 TDI, 2.0, 2.3 V5, 2.5	for OE: G73, G87;  SP	<b>F8-6041</b>	⊕ ⊕ ⊕	H=53
Rubber Buffer, suspension	1.4, 1.6, 1.8 T, 1.9 TDI, 2.0, 2.3 V5, 2.5	for OE: G80	<b>F8-6041</b>	⊕ ⊕ ⊕	H=53
Rubber Buffer, suspension	RSI 3.2 4motion		<b>F8-6041</b>	⊕ ⊕ ⊕	H=53
Protective Cap/Bellow, shock absorber	1.4, 1.6, 1.8 T, 1.9 TDI, 2.0, 2.3 V5, 2.5	for OE: UA8;  Δ	<b>F8-6044</b>	⊕ ⊕ ⊕	H=160
Protective Cap/Bellow, shock absorber	1.4, 1.6, 1.8 T, 1.9 TDI, 2.0, 2.3 V5		<b>F8-6045</b>	⊕ ⊕ ⊕	
Mounting, axle beam	1.4, 1.6, 1.8 T, 1.9 TDI, 2.0, 2.3 V5		<b>F8-6076</b>	⊕ ⊕ ⊕	d=12; L=90; D=69
Repair Set, axle beam	1.4	BCA	<b>F8-6077</b>	⊕ ⊕ ⊕	H=90; D=69
Repair Set, axle beam	1.6	AYD	<b>F8-6077</b>	⊕ ⊕ ⊕	H=90; D=69
Repair Set, axle beam	1.6, 1.9 TDI, 2.3 V5		<b>F8-6077</b>	⊕ ⊕ ⊕	H=90; D=69
Repair Set, axle beam	1.8 T	AWW	<b>F8-6077</b>	⊕ ⊕ ⊕	H=90; D=69



**Article Description****Article Nr.****Fitting Position****NEW BEETLE (9C1, 1C1) 01/1998 → 09/2010**

Repair Set, axle beam	1.9 TDI	ATD	<b>F8-6077</b>		H=90; D=69
Repair Set, axle beam	2.0	AEG	<b>F8-6077</b>		H=90; D=69
Top Strut Mounting	All Models		<b>F8-6280</b>		H=53; d=26; D=82
Belt Pulley, crankshaft	1.9 TDI	Number of Ribs: 5; Parameter: 6PK	<b>F8-6392</b>		H=47; d=30; D=143
Belt Pulley, crankshaft	1.9 TDI	ch.1C-3-432287→; Number of Ribs: 5; Parameter: 6PK	<b>F8-6396</b>		H=41.6; d=30; Mounting points diam.[mm]=7, 8.6; D=139.7
Control Arm-/Trailing Arm Bush	RSI 3.2 4motion		<b>F8-6464</b>		H=41; d=13,5; W=60
Bracket, stabilizer mounting	1.4, 1.6, 1.8 T, 1.9 TDI, 2.3 V5, 2.5, RSI 3.2 4motion		<b>F8-6579</b>		
Bracket, stabilizer mounting	1.9 TDI	ATD, BEW	<b>F8-6579</b>		
Bracket, stabilizer mounting	2.0	AEG, AQY, AZG	<b>F8-6579</b>		
Control Arm-/Trailing Arm Bush	RSI 3.2 4motion		<b>F8-6775</b>		H=54; d=12; D=45
Mounting, axle bracket	RSI 3.2 4motion		<b>F8-7046</b>		H=55; d=16; D=52
Top Strut Mounting	All Models	for OE: 1J0412319C	<b>F8-7133</b>		
Bellow, driveshaft	1.4		<b>F8-7722</b>		d1=26; d2=78; L=110
Belt Pulley, crankshaft	1.9 TDI	ch.→1C-3-432286	<b>F8-7864</b>		
Stabiliser Mounting	1.6, 1.8 T, 1.9 TDI, 2.0		<b>F8-7936</b>		
Control Arm-/Trailing Arm Bush	1.4, 1.6, 1.8 T, 1.9 TDI, 2.3 V5		<b>F8-7978</b>		
Engine Mounting	1.4		<b>F8-8198</b>		
Control Arm-/Trailing Arm Bush	1.4, 1.6, 1.8 T, 1.9 TDI, 2.0, 2.3 V5, RSI 3.2 4motion		<b>G9-648</b>		H=54; d=12; D1=33; D2=36
Control Arm-/Trailing Arm Bush	1.4, 1.6, 1.8 T, 1.9 TDI, 2.0, 2.3 V5, RSI 3.2 4motion		<b>G9-649</b>		H1=25; H2=41; d=13; D=60
Bellow, steering	All Models	with clamps;	<b>LM-10020S</b>		d1=16; d2=48; L [mm]=179

**BEETLE Convertible (15) 07/1970 → 06/1979**

Protective Cap/Bellow, shock absorber	1302,1303 1.6		<b>F8-4065</b>		H=97; d1=46; d2=76
---------------------------------------	---------------	--	----------------	--	--------------------

**LT28-50 Bus (281-363) 04/1975 → 06/1996**

Control Arm-/Trailing Arm Bush	2.0, 2.4, 2.4 D, 2.4 i, 2.4 TD		<b>F8-1013</b>		H1=19; H2=60; d=20; D1=38; D2=63
Control Arm-/Trailing Arm Bush	2.4 TD		<b>F8-1013</b>		H1=19; H2=60; d=20; D1=38; D2=63
Clamp, silencer	All Models		<b>F8-4027</b>		H=17; W=53, 61
Control Arm-/Trailing Arm Bush	All Models		<b>F8-4035</b>		H=40; d=28; D=66
Control Arm-/Trailing Arm Bush	All Models		<b>F8-4036</b>		H=33; d=28; D=66

<b>F8-1013</b>	<b>F8-4027</b>	<b>F8-4035</b>	<b>F8-4036</b>	<b>F8-4052</b>	<b>F8-4065</b>	<b>F8-6077</b>
Ref.Nr.: 281407077	Ref.Nr.: 171253147A	Ref.Nr.: 281407179	Ref.Nr.: 281407180	Ref.Nr.: 281411041	Ref.Nr.: 811412135A	Ref.Nr.: 1J0501541DS
<b>F8-6280</b>	<b>F8-6392</b>	<b>F8-6396</b>	<b>F8-6464</b>	<b>F8-6579</b>	<b>F8-6775</b>	<b>F8-7046</b>
Ref.Nr.: 6R0412249	Ref.Nr.: 038105243	Ref.Nr.: 03G105243	Ref.Nr.: 8N0407181B	Ref.Nr.: 1J0 411 336 C	Ref.Nr.: 8N0407182A	Ref.Nr.: 1J0501545B
<b>F8-7133</b>	<b>F8-7722</b>	<b>F8-7864</b>	<b>F8-7936</b>	<b>F8-7978</b>	<b>F8-8198</b>	<b>G9-648</b>
Ref.Nr.: 1J0412319C	Ref.Nr.: 191407285F	Ref.Nr.: 038 105 243	Ref.Nr.: 1J0411327A	Ref.Nr.: 357407182F	Ref.Nr.: 1J0199555BD	Ref.Nr.: 357407182

Article Description



Article Nr.

Fitting Position



<b>LT28-50 Bus (281-363)</b>			<b>04/1975 → 06/1996</b>		
Stabiliser Mounting	All Models		<b>F8-4052</b>		H=47; d=21; D1=34; D2=42
Stabiliser Mounting	2.0, 2.4, 2.4 D, 2.4 TD	; ch.28-D-007274 →; 01/1983 →	<b>F8-5100</b>	⊕ ⊕	H=40; d=12; D=37.5
Stabiliser Mounting	2.4 D, 2.4 i, 2.4 TD	; ch.28-D-007274 →	<b>F8-5100</b>	⊕ ⊕	H=40; d=12; D=37.5
Mounting, leaf spring	2.0, 2.4, 2.4 D, 2.4 i, 2.4 TD		<b>F8-5206</b>		d=12; L=75; D=49
Mounting, leaf spring	All Models		<b>F8-5207</b>		d=14; L=75; D=52
Bump Stop, stub axle	All Models		<b>F8-5808</b>	⊕ ⊕ ↓	H=80; L=120; D=13; W=68
Supporting Ring, suspension strut bearing	All Models		<b>F8-6261</b>		
<b>LT28-50 Box (281-363)</b>			<b>04/1975 → 06/1996</b>		
Control Arm-/Trailing Arm Bush	2.0, 2.4, 2.4 D, 2.4 i, 2.4 TD, 2.7 D		<b>F8-1013</b>	⊕ ⊕ ↑	H1=19; H2=60; d=20; D1=38; D2=63
Clamp, silencer	2.0, 2.4, 2.4 D, 2.4 i, 2.4 TD, 2.7 D		<b>F8-4027</b>		H=17; W=53, 61
Control Arm-/Trailing Arm Bush	2.0, 2.4, 2.4 D, 2.4 i, 2.4 TD, 2.7 D		<b>F8-4035</b>	⊕ ⊕	H=40; d=28; D=66
Control Arm-/Trailing Arm Bush	2.0, 2.4, 2.4 D, 2.4 i, 2.4 TD, 2.7 D		<b>F8-4036</b>	⊕ ⊕	H=33; d=28; D=66
Stabiliser Mounting	2.0, 2.4, 2.4 D, 2.4 i, 2.4 TD, 2.7 D		<b>F8-4052</b>		H=47; d=21; D1=34; D2=42
Stabiliser Mounting	2.0, 2.4, 2.4 D	; ch.28-D-007274 →; 01/1983 →	<b>F8-5100</b>	⊕ ⊕	H=40; d=12; D=37.5
Stabiliser Mounting	2.4 D, 2.4 i, 2.4 TD	; ch.28-D-007274 →	<b>F8-5100</b>	⊕ ⊕	H=40; d=12; D=37.5
Mounting, leaf spring	2.0, 2.4, 2.4 D, 2.4 i, 2.4 TD, 2.7 D		<b>F8-5206</b>		d=12; L=75; D=49
Mounting, leaf spring	2.0, 2.4, 2.4 D, 2.4 i, 2.4 TD, 2.7 D		<b>F8-5207</b>		d=14; L=75; D=52
Bump Stop, stub axle	2.0, 2.4, 2.4 D, 2.4 i, 2.4 TD, 2.7 D		<b>F8-5808</b>	⊕ ⊕ ↓	H=80; L=120; D=13; W=68
Supporting Ring, suspension strut bearing	All Models		<b>F8-6261</b>		
<b>LT28-50 Platform/Chassis (281-363)</b>			<b>04/1975 → 06/1996</b>		
Control Arm-/Trailing Arm Bush	2.0, 2.4, 2.4 D, 2.4 i, 2.4 TD, 2.7 D		<b>F8-1013</b>	⊕ ⊕ ↑	H1=19; H2=60; d=20; D1=38; D2=63
Clamp, silencer	2.0, 2.4, 2.4 D, 2.4 i, 2.4 TD, 2.7 D		<b>F8-4027</b>		H=17; W=53, 61
Control Arm-/Trailing Arm Bush	2.0, 2.4, 2.4 D, 2.4 i, 2.4 TD, 2.7 D		<b>F8-4035</b>	⊕ ⊕	H=40; d=28; D=66
Control Arm-/Trailing Arm Bush	2.0, 2.4, 2.4 D, 2.4 i, 2.4 TD, 2.7 D		<b>F8-4036</b>	⊕ ⊕	H=33; d=28; D=66
Stabiliser Mounting	2.0, 2.4, 2.4 D, 2.4 i, 2.4 TD, 2.7 D		<b>F8-4052</b>		H=47; d=21; D1=34; D2=42
Stabiliser Mounting	2.0, 2.4, 2.4 D, 2.4 TD	; ch.28-D-007274 →; 01/1983 →	<b>F8-5100</b>	⊕ ⊕	H=40; d=12; D=37.5
Stabiliser Mounting	2.4 D, 2.4 i, 2.4 TD	; ch.28-D-007274 →	<b>F8-5100</b>	⊕ ⊕	H=40; d=12; D=37.5
Mounting, leaf spring	2.0, 2.4, 2.4 D, 2.4 i, 2.4 TD, 2.7 D		<b>F8-5206</b>		d=12; L=75; D=49
Mounting, leaf spring	2.0, 2.4, 2.4 D, 2.4 i, 2.4 TD, 2.7 D		<b>F8-5207</b>		d=14; L=75; D=52
Bump Stop, stub axle	2.0, 2.4, 2.4 D, 2.4 i, 2.4 TD, 2.7 D		<b>F8-5808</b>	⊕ ⊕ ↓	H=80; L=120; D=13; W=68





**Article Description****Article Nr.****Fitting Position****LT28-50 Platform/Chassis (281-363)****04/1975 → 06/1996**

Supporting Ring, suspension strut bearing	All Models		<b>F8-6261</b>		
<b>LT Mk II Bus (2DB, 2DE, 2DK)</b>			<b>05/1996 → 07/2006</b>		
Dust Cover Kit, shock absorber	All Models		<b>AK-735418</b>		H=200
Alternator Freewheel Clutch	2.8 TDi		<b>F5-1031</b>		
Bush, leaf spring	2.3, 2.5 SDI, 2.5 TDI		<b>F8-5019</b>		H=80; d=12; D1=24; D2=39
Bearing Bush, stabiliser	2.3, 2.5 SDI, 2.5 TDI		<b>F8-5261</b>		d=13,5
Stabiliser Mounting	2.3, 2.5 SDI, 2.5 TDI, 2.8 TDi		<b>F8-5378</b>		d=25; W=30
Stabiliser Mounting	2.3, 2.5 SDI, 2.5 TDI		<b>F8-5453</b>		
Stabiliser Mounting	2.3, 2.5 SDI, 2.5 TDI		<b>F8-5752</b>		H=26; d=12; D=26
Mounting, leaf spring	All Models		<b>F8-5788</b>		H=80; d=12.2; D=50
Stabiliser Mounting	2.3, 2.5 SDI, 2.5 TDI		<b>F8-5846</b>		H=39; d=23; D=35
Bush, leaf spring	All Models		<b>F8-5979</b>		d=12; L=134
Mounting, propshaft	All Models		<b>F8-6240</b>		
Control Arm-/Trailing Arm Bush	All Models		<b>F8-6529</b>		
Top Strut Mounting	All Models		<b>F8-6700</b>		
Top Strut Mounting	All Models		<b>F8-6704</b>		
Protective Cap/Bellow, shock absorber	All Models		<b>F8-7160</b>		H=200
Mounting, automatic transmission	2.3, 2.5 SDI, 2.5 TDI		<b>F8-8144</b>		
Engine Mounting	2.5 SDI, 2.5 TDI		<b>F8-8147</b>		

**LT Mk II Box (2DA, 2DD, 2DH)****05/1996 → 07/2006**

Dust Cover Kit, shock absorber	All Models		<b>AK-735418</b>		H=200
Alternator Freewheel Clutch	2.8 TDI		<b>F5-1031</b>		
Bush, leaf spring	2.3, 2.5 SDI, 2.5 TDI, 2.8 TDI		<b>F8-5019</b>		H=80; d=12; D1=24; D2=39
Bearing Bush, stabiliser	All Models		<b>F8-5261</b>		d=13,5
Stabiliser Mounting	All Models		<b>F8-5378</b>		d=25; W=30
Stabiliser Mounting	All Models		<b>F8-5453</b>		
Mounting, leaf spring	All Models		<b>F8-5788</b>		H=80; d=12.2; D=50
Stabiliser Mounting	All Models		<b>F8-5846</b>		H=39; d=23; D=35
Bush, leaf spring	All Models		<b>F8-5979</b>		d=12; L=134
Mounting, propshaft	All Models		<b>F8-6240</b>		
Control Arm-/Trailing Arm Bush	All Models		<b>F8-6529</b>		
Top Strut Mounting	All Models		<b>F8-6700</b>		

<b>AK-735418</b>	<b>F5-1031</b>	<b>F8-5019</b>	<b>F8-5261</b>	<b>F8-5378</b>	<b>F8-5453</b>	<b>F8-5752</b>
Ref.Nr.: 2D0412135	Ref.Nr.: 021903119H	Ref.Nr.: 2D0511171	Ref.Nr.: 2D0411041A	Ref.Nr.: 9043230085	Ref.Nr.: 2D0511413B	Ref.Nr.: 5103955AB
<b>F8-5788</b>	<b>F8-5846</b>	<b>F8-5979</b>	<b>F8-6240</b>	<b>F8-6261</b>	<b>F8-6529</b>	<b>F8-6700</b>
Ref.Nr.: 2D0511171B	Ref.Nr.: 2D0511413A	Ref.Nr.: 2D0511181	Ref.Nr.: 2D0 598 351	Ref.Nr.: 411513121	Ref.Nr.: 2D0 407 140	Ref.Nr.: 2D0407183
<b>F8-6704</b>	<b>F8-7160</b>	<b>F8-8144</b>	<b>F8-8147</b>			
Ref.Nr.: 2D0407183A	Ref.Nr.: 2D0412135	Ref.Nr.: 2D0199379B	Ref.Nr.: 2D0199379A			

<b>Article Description</b>			<b>Article Nr.</b>	<b>Fitting Position</b>	
----------------------------	--	--	--------------------	-------------------------	--

**LT Mk II Box (2DA, 2DD, 2DH)** 05/1996 → 07/2006

Top Strut Mounting	All Models		<b>F8-6704</b>		
Protective Cap/Bellow, shock absorber	All Models		<b>F8-7160</b>		H=200
Mounting, automatic transmission	2.3, 2.5 SDI, 2.5 TDI		<b>F8-8144</b>		
Engine Mounting	2.5 SDI, 2.5 TDI		<b>F8-8147</b>		

**LT Mk II Platform/Chassis (2DC, 2DF, 2DG, 2DL, 2DM)** 06/1996 → 07/2006

Dust Cover Kit, shock absorber	All Models		<b>AK-735418</b>		H=200
Alternator Freewheel Clutch	2.8 TDI		<b>F5-1031</b>		
Bush, leaf spring	2.3, 2.5 SDI, 2.5 TDI, 2.8 TDI		<b>F8-5019</b>		H=80; d=12; D1=24; D2=39
Bearing Bush, stabiliser	All Models		<b>F8-5261</b>		d=13,5
Stabiliser Mounting	All Models		<b>F8-5378</b>		d=25; W=30
Stabiliser Mounting	All Models		<b>F8-5453</b>		
Mounting, leaf spring	All Models		<b>F8-5788</b>		H=80; d=12.2; D=50
Stabiliser Mounting	All Models		<b>F8-5846</b>		H=39; d=23; D=35
Bush, leaf spring	All Models		<b>F8-5979</b>		d=12; L=134
Mounting, propshaft	All Models		<b>F8-6240</b>		
Control Arm-/Trailing Arm Bush	All Models		<b>F8-6529</b>		
Top Strut Mounting	All Models		<b>F8-6700</b>		
Top Strut Mounting	All Models		<b>F8-6704</b>		
Protective Cap/Bellow, shock absorber	All Models		<b>F8-7160</b>		H=200
Mounting, automatic transmission	2.3, 2.5 SDI, 2.5 TDI		<b>F8-8144</b>		
Engine Mounting	2.5 SDI, 2.5 TDI		<b>F8-8147</b>		

**LT 40-55 I Box (291-512)** 04/1975 → 06/1996

Control Arm-/Trailing Arm Bush	2.0, 2.4, 2.4 4WD, 2.4 D, 2.4 D 4WD, 2.4 i, 2.4 TD, 2.4 TD 4WD		<b>F8-1013</b>		H1=19; H2=60; d=20; D1=38; D2=63
Mounting, leaf spring	2.4 TD		<b>F8-5206</b>		d=12; L=75; D=49
Supporting Ring, suspension strut bearing	All Models		<b>F8-6261</b>		

**LT 40-55 I Platform/Chassis (293-909)** 04/1975 → 06/1996

Control Arm-/Trailing Arm Bush	2.0, 2.4 D, 2.4 i, 2.4 TD		<b>F8-1013</b>		H1=19; H2=60; d=20; D1=38; D2=63
Mounting, leaf spring	2.0, 2.4 D, 2.4 i, 2.4 TD		<b>F8-5206</b>		d=12; L=75; D=49
Supporting Ring, suspension strut bearing	All Models		<b>F8-6261</b>		

<b>AK-735418</b>	<b>F5-1031</b>	<b>F8-1013</b>	<b>F8-5019</b>	<b>F8-5206</b>	<b>F8-5261</b>	<b>F8-5378</b>
Ref.Nr.: 2D0412135	Ref.Nr.: 021903119H	Ref.Nr.: 281407077	Ref.Nr.: 2D0511171	Ref.Nr.: 291511181	Ref.Nr.: 2D0411041A	Ref.Nr.: 9043230085
<b>F8-5453</b>	<b>F8-5788</b>	<b>F8-5846</b>	<b>F8-5979</b>	<b>F8-6240</b>	<b>F8-6261</b>	<b>F8-6529</b>
Ref.Nr.: 2D0511413B	Ref.Nr.: 2D0511171B	Ref.Nr.: 2D0511413A	Ref.Nr.: 2D0511181	Ref.Nr.: 2D0 598 351	Ref.Nr.: 411513121	Ref.Nr.: 2D0 407 140
<b>F8-6700</b>	<b>F8-6704</b>	<b>F8-7160</b>	<b>F8-8144</b>	<b>F8-8147</b>		
Ref.Nr.: 2D0407183	Ref.Nr.: 2D0407183A	Ref.Nr.: 2D0412135	Ref.Nr.: 2D0199379B	Ref.Nr.: 2D0199379A		

**Article Description****Article Nr.****Fitting Position**

<b>LUPO (6X1, 6E1)</b>			<b>09/1998 → 07/2005</b>	
Dust Cover Kit, shock absorber	1.0, 1.2 TDI 3L, 1.4, 1.4 16V, 1.4 FSI, 1.4 TDI, 1.6 GTI, 1.7 SDI		<b>AK-735031</b>	
Dust Cover Kit, shock absorber	1.0, 1.2 TDI 3L, 1.4, 1.4 16V, 1.4 TDI, 1.7 SDI		<b>AK-735409</b>	
Dust Cover Kit, shock absorber	All Models	<b>ST</b>	<b>AK-735410</b>	H=210
Alternator Freewheel Clutch	1.2 TDI 3L, 1.4 TDI		<b>F5-1004</b>	
Alternator Freewheel Clutch	1.7 SDI		<b>F5-1011</b>	
Anti-Friction Bearing	All Models		<b>F8-3039</b>	H=14; d=14; D=45
Bellow, steering	1.0, 1.4 16V, 1.7 SDI		<b>F8-5061</b>	
Control Arm-/Trailing Arm Bush	1.0, 1.2 TDI 3L, 1.4, 1.4 16V, 1.4 TDI, 1.7 SDI		<b>F8-5104</b>	H=47; d=10; D=28
Control Arm-/Trailing Arm Bush	1.0, 1.2 TDI 3L, 1.4, 1.4 16V, 1.4 TDI, 1.7 SDI		<b>F8-5105</b>	H=46; d=17; D=61
Mounting, axle beam	1.0, 1.4, 1.4 16V, 1.4 FSI, 1.4 TDI, 1.6 GTI, 1.7 SDI		<b>F8-5341</b>	H=58; d=10; D=58
Repair Set, axle beam	1.0, 1.4, 1.4 16V, 1.4 FSI, 1.4 TDI, 1.6 GTI, 1.7 SDI		<b>F8-5341S</b>	d=10; D=58
Engine Mounting	1.4 16V	04/1998 →;	<b>F8-5386</b>	
Top Strut Mounting	All Models		<b>F8-5494</b>	d=26; D=83
Top Strut Mounting	1.0, 1.2 TDI 3L, 1.4, 1.4 16V, 1.4 FSI, 1.4 TDI, 1.6 GTI, 1.7 SDI		<b>F8-5523</b>	
Top Strut Mounting	1.0, 1.2 TDI 3L, 1.4, 1.4 16V, 1.4 FSI, 1.4 TDI, 1.6 GTI, 1.7 SDI		<b>F8-5537</b>	
Engine Mounting	1.0, 1.4, 1.4 16V		<b>F8-5540</b>	
Spring Cap	1.0, 1.2 TDI 3L, 1.4, 1.4 16V, 1.4 FSI, 1.4 TDI, 1.6 GTI, 1.7 SDI		<b>F8-5580</b>	D=92
Protective Cap/Bellow, shock absorber	All Models		<b>F8-5683</b>	H=210
Rubber Buffer, suspension	1.0, 1.2 TDI 3L, 1.4, 1.4 16V, 1.4 FSI, 1.4 TDI, 1.6 GTI, 1.7 SDI	<b>ST</b>	<b>F8-5996</b>	H=63
Rubber Buffer, suspension	1.0, 1.2 TDI 3L, 1.4, 1.4 16V, 1.4 TDI, 1.7 SDI		<b>F8-6002</b>	H=120
Protective Cap/Bellow, shock absorber	All Models		<b>F8-6044</b>	H=160
Stabiliser Mounting	1.0, 1.2 TDI 3L, 1.4, 1.4 16V, 1.4 FSI, 1.4 TDI, 1.6 GTI, 1.7 SDI	Stabi. Diam. [mm]= 18	<b>F8-6190</b>	d=16
Stabiliser Mounting	1.0, 1.2 TDI 3L, 1.4, 1.4 16V, 1.4 FSI, 1.4 TDI, 1.6 GTI, 1.7 SDI	for OE: 0AD / 0AH; Stabi. Diam. [mm]= 20, 22	<b>F8-6191</b>	d=18
Belt Pulley, crankshaft	1.7 SDI	Number of Ribs: 5	<b>F8-6398</b>	
Engine Mounting	1.0	ch.→6X-Y-070000;  AER, ALD, ALL, ANV	<b>F8-6501</b>	
Engine Mounting	1.4	ch.→6X-Y-070000	<b>F8-6501</b>	
Engine Mounting	1.0	AER, ALD, ALL, ANV, AUC;	<b>F8-6923</b>	
Engine Mounting	1.4 16V	AFK, AQQ, AUB;	<b>F8-6923</b>	

<b>AK-735031</b>	<b>AK-735409</b>	<b>AK-735410</b>	<b>F5-1004</b>	<b>F5-1011</b>	<b>F8-3039</b>	<b>F8-5061</b>
Ref.Nr.:	Ref.Nr.: 1J0513425	Ref.Nr.: 1J0412303	Ref.Nr.: 038903119T	Ref.Nr.: 038903119Q	Ref.Nr.: 357412249A	Ref.Nr.: 6N0419831
<b>F8-5104</b>	<b>F8-5105</b>	<b>F8-5341</b>	<b>F8-5341S</b>	<b>F8-5386</b>	<b>F8-5494</b>	<b>F8-5523</b>
Ref.Nr.: 6N0407182	Ref.Nr.: 6N0407181	Ref.Nr.: 6N0501541D	Ref.Nr.: 6N0501541D	Ref.Nr.: 1J0199555AJ	Ref.Nr.: 6N0412331	Ref.Nr.: 6N0412331A
<b>F8-5537</b>	<b>F8-5540</b>	<b>F8-5580</b>	<b>F8-5683</b>	<b>F8-5996</b>	<b>F8-6002</b>	<b>F8-6044</b>
Ref.Nr.: 6N0412331E	Ref.Nr.: 6N0199262L	Ref.Nr.: 1J0412341	Ref.Nr.: 357413175A	Ref.Nr.: 1H0412303B	Ref.Nr.: 6X0512131A	Ref.Nr.: 3C0513425

Article Description



Article Nr.

Fitting Position



### LUPO (6X1, 6E1)

09/1998 → 07/2005

Engine Mounting	1.4 FSI		F8-6923	⊕	
Engine Mounting	1.4, 1.4 16V		F8-6923	⊕	
Bellow, driveshaft	1.0, 1.4, 1.4 16V, 1.7 SDI		F8-7722	⊕ ⊕	d1=26; d2=78; L=110
Bellow, driveshaft	1.4 16V, 1.4 FSI	/ optional	F8-7722	⊕ ⊕	d1=26; d2=78; L=110
Engine Mounting	1.0, 1.4 16V, 1.4 FSI		F8-7948	⊕	
Engine Mounting	1.4 16V	AHW, AKQ, APE, AUA	F8-7948	⊕	
Engine Mounting	1.4 16V	BBY;	F8-7954		
Belt Pulley, crankshaft	1.4 TDI	Number of Ribs: 5; Parameter: 6PK	F8-8038		
Engine Mounting	1.7 SDI		F8-8189	⊕	
Bellow, steering	All Models	with clamps	LM-10063S		d1=11; d2=42; L [mm]=208
Bellow, steering	All Models	with clamps;	LM-10088S		d1=25; d2=40; L [mm]=143

### PASSAT (32)

05/1973 → 07/1980

Dust Cover Kit, shock absorber	1.3, 1.5, 1.5 D, 1.6		AK-733023	⊕ ⊕	
Engine Mounting	1.3, 1.5, 1.5 D, 1.6		F8-1031	⊕ ⊕	H=47; d=10; D1=36; D2=52
Engine Mounting	1.3	01/1978 →	F8-3000	⊕	H=60; Thick. [mm]=66; W=89
Engine Mounting	1.3		F8-3000	⊕	H=60; Thick. [mm]=66; W=89
Engine Mounting	1.5 D	;	F8-3000	⊕ ⊕	H=60; Thick. [mm]=66; W=89
Engine Mounting	1.6		F8-3000	⊕ ⊕	H=60; Thick. [mm]=66; W=89
Anti-Friction Bearing	1.3, 1.5, 1.5 D, 1.6		F8-3036	⊕ ⊕	
Flange, carburettor	1.6	ch.3292000001 →; 01/1979 →	F8-3046		H=23
Mounting, radiator	1.3, 1.5, 1.5 D, 1.6		F8-4011		H1=16; H2=38; D=30; Outer Thread [mm]=M8 x 1,25
Rubber Buffer, silencer	1.3, 1.5, 1.5 D		F8-4026		H=12; W=57, 60
Stabiliser Mounting	1.3, 1.5, 1.5 D, 1.6		F8-5225	⊕ ⊕	d=19
Engine Mounting	1.3, 1.5, 1.5 D, 1.6		F8-5685	⊕ ⊕	H=36; d=10; D=40.5
Mounting, axle beam	1.3, 1.5, 1.5 D, 1.6		F8-5686	⊕ ⊕	H=38; d=10; D=36.3

### PASSAT Variant (33)

05/1973 → 07/1980

Dust Cover Kit, shock absorber	1.3, 1.5, 1.5 D, 1.6, 1.6 i		AK-733023	⊕ ⊕	
Engine Mounting	1.3, 1.5, 1.5 D, 1.6, 1.6 i		F8-1031	⊕ ⊕	H=47; d=10; D1=36; D2=52
Engine Mounting	1.3	01/1978 →	F8-3000	⊕	H=60; Thick. [mm]=66; W=89
Engine Mounting	1.3		F8-3000	⊕ ⊕	H=60; Thick. [mm]=66; W=89
Engine Mounting	1.5 D	;	F8-3000	⊕ ⊕	H=60; Thick. [mm]=66; W=89
Engine Mounting	1.6		F8-3000	⊕ ⊕	H=60; Thick. [mm]=66; W=89
Anti-Friction Bearing	1.3, 1.5, 1.5 D, 1.6, 1.6 D, 1.6 i		F8-3036	⊕ ⊕	
Flange, carburettor	1.6	ch.3292000001 →; 01/1979 →	F8-3046		H=23

<b>AK-733023</b>	<b>F8-1031</b>	<b>F8-3000</b>	<b>F8-3036</b>	<b>F8-3046</b>	<b>F8-4011</b>	<b>F8-4026</b>
Ref.Nr.: 191412303	Ref.Nr.: 811199415A	Ref.Nr.: 823199381B	Ref.Nr.: 377412335A	Ref.Nr.: 049129761	Ref.Nr.: 803121273	Ref.Nr.: 817253147
<b>F8-5225</b>	<b>F8-5685</b>	<b>F8-5686</b>	<b>F8-6923</b>	<b>F8-7722</b>	<b>F8-7948</b>	<b>F8-7954</b>
Ref.Nr.: 823411327B	Ref.Nr.: 811199419A	Ref.Nr.: 823511247A	Ref.Nr.: 6N0199555AA	Ref.Nr.: 191407285F	Ref.Nr.: 6N0199262G	Ref.Nr.: 6Q0199851AL
<b>F8-8038</b>	<b>F8-8189</b>	<b>LM-10063S</b>	<b>LM-10088S</b>			
Ref.Nr.: 045105243C	Ref.Nr.: 6N0199555H	Ref.Nr.: 6N0422831	Ref.Nr.: 6N0419831			

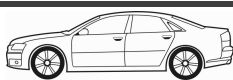
**Article Description****Article Nr.****Fitting Position**

<b>PASSAT Variant (33)</b>			<b>05/1973 → 07/1980</b>	
Mounting, radiator	1.3, 1.5, 1.5 D, 1.6, 1.6 D, 1.6 i		<b>F8-4011</b>	H1=16; H2=38; D=30; Outer Thread [mm]=M8 x 1,25
Rubber Buffer, silencer	1.3, 1.5, 1.5 D, 1.6, 1.6 D		<b>F8-4026</b>	H=12; W=57, 60
Stabiliser Mounting	1.3, 1.5, 1.5 D, 1.6, 1.6 i		<b>F8-5225</b>	d=19
Engine Mounting	1.3, 1.5, 1.5 D, 1.6, 1.6 i		<b>F8-5685</b>	H=36; d=10; D=40.5
Mounting, axle beam	1.3, 1.5, 1.5 D, 1.6, 1.6 i		<b>F8-5686</b>	H=38; d=10; D=36.3
<b>PASSAT (32B)</b>			<b>08/1980 → 03/1988</b>	
Dust Cover Kit, shock absorber	1.3, 1.6, 1.6 D, 1.6 TD, 1.8, 2.0, 2.2	△	<b>AK-732516</b>	
Dust Cover Kit, shock absorber	1.9	04/1983 →; △	<b>AK-732516</b>	
Dust Cover Kit, shock absorber	1.3, 1.6, 1.6 D, 1.6 TD, 1.8, 1.9, 2.0, 2.2		<b>AK-733023</b>	
Control Arm-/Trailing Arm Bush	1.6	without guide sleeve	<b>F8-1007</b>	H1=26; H2=41; d=17; D1=60; D2=68
Control Arm-/Trailing Arm Bush	1.6	with guide sleeve	<b>F8-1007S</b>	H1=26; H2=41; d=17; D1=60; D2=68
Mounting, axle beam	1.3, 1.6, 1.6 D, 1.6 TD, 1.8, 1.9, 2.0, 2.2		<b>F8-1014</b>	H1=32; H2=40; d=12; D1=44; D2=70
Engine Mounting	2.0, 2.2	ch.32F332884 →	<b>F8-1020</b>	H=97; D=114; τ [mm]=145
Engine Mounting	2.0, 2.2	ch.32H175001 →; ⚙	<b>F8-1020</b>	H=97; D=114; τ [mm]=145
Engine Mounting	2.0	01/1985 →; ⚙	<b>F8-1021</b>	H=97; D=114; τ [mm]=143
Engine Mounting	2.2	⚙	<b>F8-1021</b>	H=97; D=114; τ [mm]=143
Control Arm-/Trailing Arm Bush	1.3, 1.6, 1.6 D, 1.6 TD, 1.8, 1.9, 2.0, 2.2	⊕	<b>F8-1026</b>	H=44; d=10; D1=38; D2=48
Top Strut Mounting	1.3, 1.6, 1.6 D, 1.6 TD, 1.8, 1.9, 2.0, 2.2	⊗	<b>F8-1027</b>	H=37; d1=14; d2=20; D=76
Stabiliser Mounting	1.3, 1.6, 1.6 D, 1.6 TD, 1.8, 1.9, 2.0, 2.2	⊗	<b>F8-1029</b>	H=42; Thick. [mm]=25; W=38
Stabiliser Mounting	1.8	01/1985 →	<b>F8-1029</b>	H=42; Thick. [mm]=25; W=38
Engine Mounting	1.3, 1.6, 1.6 D, 1.6 TD, 1.8		<b>F8-1031</b>	H=47; d=10; D1=36; D2=52
Engine Mounting	1.3, 1.6, 1.6 D, 1.6 TD, 1.8, 2.0, 2.2		<b>F8-1032</b>	D=10; H=42; D1=38; D2=46
Engine Mounting	1.3		<b>F8-3000</b>	H=60; Thick. [mm]=66; W=89
Engine Mounting	1.6	01/1982 →; ⚙	<b>F8-3000</b>	H=60; Thick. [mm]=66; W=89
Engine Mounting	1.6, 1.6 D, 1.6 TD, 1.8	⚙	<b>F8-3000</b>	H=60; Thick. [mm]=66; W=89
Anti-Friction Bearing	All Models		<b>F8-3036</b>	
Flange, carburettor	1.6	01/1983 →	<b>F8-3044</b>	H=21
Flange, carburettor	1.6, 1.8		<b>F8-3044</b>	H=21
Flange, carburettor	1.3	01/1982 →	<b>F8-3045</b>	H=21
Flange, carburettor	1.3, 1.6, 1.6 D, 1.6 TD, 1.8, 1.9, 2.0, 2.1, 2.2		<b>F8-3045</b>	H=21
Flange, carburettor	1.6		<b>F8-3046</b>	H=23
Flange, carburettor	1.6, 1.8		<b>F8-3047</b>	H=24

<b>AK-732516</b>	<b>AK-733023</b>	<b>F8-1007</b>	<b>F8-1007S</b>	<b>F8-1014</b>	<b>F8-1020</b>	<b>F8-1021</b>
Ref.Nr.:	Ref.Nr.: 191412303	Ref.Nr.: 191407181A	Ref.Nr.: 191407181A	Ref.Nr.: 321501541	Ref.Nr.: 443199379	Ref.Nr.: 443199382
<b>F8-1026</b>	<b>F8-1027</b>	<b>F8-1029</b>	<b>F8-1031</b>	<b>F8-1032</b>	<b>F8-3000</b>	<b>F8-3036</b>
Ref.Nr.: 811407181A	Ref.Nr.: 811412323D	Ref.Nr.: 823411313A	Ref.Nr.: 811199415A	Ref.Nr.: 811199419B	Ref.Nr.: 823199381B	Ref.Nr.: 377412335A
<b>F8-3044</b>	<b>F8-3045</b>	<b>F8-3046</b>	<b>F8-3047</b>	<b>F8-4009</b>	<b>F8-4011</b>	<b>F8-4026</b>
Ref.Nr.: 026129761A	Ref.Nr.: 027129761	Ref.Nr.: 049129761	Ref.Nr.: 050129761C	Ref.Nr.: 431121273	Ref.Nr.: 803121273	Ref.Nr.: 817253147

Article Description



Article Nr.

Fitting Position



**PASSAT (32B)**

08/1980 → 03/1988

Mounting, radiator	1.9, 2.1, 2.2		<b>F8-4009</b>		H1=15; H2=37; D=39; Outer Thread [mm]=M8 x 1,50
Mounting, radiator	2.0	JS	<b>F8-4009</b>		H1=15; H2=37; D=39; Outer Thread [mm]=M8 x 1,50
Rubber Buffer, silencer	1.6		<b>F8-4026</b>		H=12; W=57, 60
Mounting, automatic transmission	1.3, 1.6, 1.8, 2.0		<b>F8-4028</b>		H=42; D=11; D1=50; D2=80; T [mm]=94
Mounting, automatic transmission	1.6, 1.6 D, 1.6 TD, 1.8, 2.2		<b>F8-4028</b>		H=42; D=11; D1=50; D2=80; T [mm]=94
Mounting, manual transmission	1.3, 1.6, 1.6 D, 1.6 TD, 1.8		<b>F8-4030</b>	⊕	H=50; d=14; D=84
Control Arm-/Trailing Arm Bush	1.3, 1.6, 1.6 D, 1.6 TD, 1.8	ch.32-E-150001→; 01/1984 →	<b>F8-4043</b>	⊕ ⊕	H=44; d=10; D1=37; D2=54
Control Arm-/Trailing Arm Bush	1.6, 1.8, 2.2		<b>F8-4043</b>	⊕ ⊕	H=44; d=10; D1=37; D2=54
Control Arm-/Trailing Arm Bush	1.9	ch.32-D-099298→; 01/1983 →	<b>F8-4043</b>	⊕ ⊕	H=44; d=10; D1=37; D2=54
Control Arm-/Trailing Arm Bush	2.0	01/1985 →	<b>F8-4043</b>	⊕ ⊕	H=44; d=10; D1=37; D2=54
Rubber Buffer, suspension	1.3, 1.6, 1.6 D, 1.6 TD, 1.8, 1.9, 2.0, 2.2		<b>F8-4062</b>		H=67; d1=20; d2=24; D=52
Protective Cap/Bellow, shock absorber	1.3, 1.6, 1.6 D, 1.6 TD, 1.8, 1.9, 2.0, 2.2		<b>F8-4065</b>		H=97; d1=46; d2=76
Bellow, steering	1.3, 1.6, 1.6 D, 1.6 TD, 1.8, 1.9, 2.0, 2.2		<b>F8-4073</b>	⊕ ⊕	H=147; D=48
Bellow, driveshaft	1.3, 1.6, 1.6 D, 1.6 TD, 1.8		<b>F8-4080</b>	⊕ ⊕	H=95; D1=29; D2=96
Stabiliser Mounting	1.3, 1.6, 1.6 D, 1.6 TD, 1.8, 2.0, 2.2	ch.32-F-390001→; ch.→32-J-290000	<b>F8-5081</b>		d=20
Stabiliser Mounting	1.3, 1.6, 1.6 D, 1.6 TD, 1.8, 1.9, 2.0, 2.1, 2.2		<b>F8-5225</b>	⊕ ⊕	d=19
Rubber Buffer, suspension	1.3	EP	<b>F8-5673</b>	⊕ ⊕	Thick. [mm]=160
Rubber Buffer, suspension	1.3, 1.6, 1.6 D, 1.6 TD, 1.8, 1.9, 2.0, 2.1, 2.2		<b>F8-5673</b>	⊕ ⊕	Thick. [mm]=160
Engine Mounting	1.6, 1.6 D, 1.8, 1.9, 2.0, 2.1, 2.2		<b>F8-5685</b>	⊕ ⊕	H=36; d=10; D=40.5
Mounting, axle beam	1.6		<b>F8-5686</b>	⊕ ⊕	H=38; d=10; D=36.3
Engine Mounting	1.6, 1.6 D, 1.6 TD, 1.8		<b>F8-6834</b>	⊕	
Engine Mounting	1.9, 2.1		<b>F8-6925</b>	⊕ ⊕	
Engine Mounting	2.0	ch.32-F-000001→; ch.→32-E-300000;	<b>F8-6925</b>	⊕ ⊕	
Engine Mounting	2.2	ch.→32-F-332883, 32-H-175000;	<b>F8-6925</b>	⊕ ⊕	
Bellow, driveshaft	1.3	ch.→31-L-400000;  EP	<b>F8-7722</b>	⊕ ⊕	d1=26; d2=78; L=110
Bellow, driveshaft	1.3, 1.6, 1.6 D, 1.6 TD, 1.8	ch.→31-L-400000	<b>F8-7722</b>	⊕ ⊕	d1=26; d2=78; L=110
Bellow, driveshaft	1.9, 2.1	ch.→32-D-099297	<b>F8-7722</b>	⊕ ⊕	d1=26; d2=78; L=110
Bellow, driveshaft	2.0	ch.→32-D-099297;  JS	<b>F8-7722</b>	⊕ ⊕	d1=26; d2=78; L=110
Bellow, steering	All Models	with clamps	<b>LM-10026S</b>		d1=27; d2=45; L [mm]=150

<b>F8-4009</b>	<b>F8-4026</b>	<b>F8-4028</b>	<b>F8-4030</b>	<b>F8-4043</b>	<b>F8-4062</b>	<b>F8-4065</b>
Ref.Nr.: 431121273	Ref.Nr.: 817253147	Ref.Nr.: 431399151D	Ref.Nr.: 811399151B	Ref.Nr.: 8A0407181	Ref.Nr.: 811412131A	Ref.Nr.: 811412135A
<b>F8-4073</b>	<b>F8-4080</b>	<b>F8-5081</b>	<b>F8-5225</b>	<b>F8-5673</b>	<b>F8-5685</b>	<b>F8-5686</b>
Ref.Nr.: 811419831B	Ref.Nr.: 113501149	Ref.Nr.: 811411327A	Ref.Nr.: 823411327B	Ref.Nr.: 321512131B	Ref.Nr.: 811199419A	Ref.Nr.: 823511247A
<b>F8-6834</b>	<b>F8-6925</b>	<b>F8-7722</b>	<b>LM-10026S</b>	<b>M-830220</b>		
Ref.Nr.: 823199381C	Ref.Nr.: 443199381J	Ref.Nr.: 191407285F	Ref.Nr.: 811419831B	Ref.Nr.: 191498203C		

**Article Description****Article Nr.****Fitting Position**

<b>PASSAT (32B)</b>			<b>08/1980 → 03/1988</b>	
Bellow, driveshaft	1.3, 1.6, 1.6 D, 1.6 TD, 1.8, 1.9, 2.0, 2.1		<b>M-830220</b>	
Bellow Set, drive shaft	1.3	ch.→31-L-400000;  EP	<b>MK-830220</b>	
Bellow Set, drive shaft	1.3, 1.6, 1.6 D, 1.8	ch.→31-L-400000	<b>MK-830220</b>	
Bellow Set, drive shaft	1.6	ch.→31-L-400000, 33-H-086636	<b>MK-830220</b>	
Bellow Set, drive shaft	1.6 TD, 1.8, 2.2	ch.→33-H-086636	<b>MK-830220</b>	
Bellow Set, drive shaft	1.9, 2.1	ch.→32-D-099297	<b>MK-830220</b>	
Bellow Set, drive shaft	2.0	ch.→32-D-099297;  JS	<b>MK-830220</b>	
<b>PASSAT Variant (32B)</b>			<b>08/1980 → 07/1988</b>	
Dust Cover Kit, shock absorber	1.3, 1.6, 1.6 D, 1.6 TD, 1.8, 1.9, 2.0, 2.2		<b>AK-732516</b>	
Dust Cover Kit, shock absorber	1.3, 1.6, 1.6 D, 1.6 TD, 1.8, 1.8 Syncro, 1.9, 2.0, 2.0 Syncro, 2.2, 2.2 Syncro		<b>AK-733023</b>	
Mounting, axle beam	1.6 D		<b>F8-1014</b>	
Engine Mounting	2.0, 2.2	ch.32F332884→	<b>F8-1020</b>	
Engine Mounting	2.0, 2.2	ch.32H175001→;	<b>F8-1020</b>	
Control Arm-/Trailing Arm Bush	1.6 D		<b>F8-1026</b>	
Top Strut Mounting	1.3, 1.6, 1.6 D, 1.9		<b>F8-1027</b>	
Top Strut Mounting	1.6, 1.6 TD, 1.8, 1.8 Syncro, 2.0, 2.2, 2.2 Syncro	ch.→32-J-299999;	<b>F8-1027</b>	
Stabiliser Mounting	1.6 D		<b>F8-1029</b>	
Engine Mounting	1.6 D		<b>F8-1031</b>	
Engine Mounting	1.6 D		<b>F8-1032</b>	
Engine Mounting	1.6 D		<b>F8-3000</b>	
Anti-Friction Bearing	1.3, 1.6, 1.6 D, 1.6 TD, 1.8, 1.8 Syncro, 1.9, 2.0, 2.0 Syncro, 2.1, 2.2, 2.2 Syncro		<b>F8-3036</b>	
Flange, carburettor	1.3, 1.6, 1.6 D, 1.6 TD, 1.8, 1.9, 2.0, 2.1, 2.2		<b>F8-3045</b>	
Flange, carburettor	1.6, 1.8		<b>F8-3047</b>	
Mounting, radiator	1.9, 2.0 Syncro, 2.1, 2.2, 2.2 Syncro		<b>F8-4009</b>	
Mounting, radiator	2.0	JS	<b>F8-4009</b>	
Mounting, manual transmission	1.6 D		<b>F8-4030</b>	
Control Arm-/Trailing Arm Bush	1.6 D	ch.32-E-150001→; 01/1984 →	<b>F8-4043</b>	
Rubber Buffer, suspension	1.6 D		<b>F8-4062</b>	
Protective Cap/Bellow, shock absorber	1.3, 1.6, 1.6 D, 1.6 TD, 1.8, 1.9, 2.0, 2.2		<b>F8-4065</b>	
Bellow, steering	1.3, 1.6, 1.6 D, 1.6 TD, 1.8, 1.8 Syncro, 1.9, 2.0, 2.0 Syncro, 2.2, 2.2 Syncro		<b>F8-4073</b>	



Article Description



Article Nr.

Fitting Position



### PASSAT Variant (32B)

08/1980 → 07/1988

Bellow, driveshaft	1.3, 1.6, 1.6 D, 1.6 TD, 1.8		<b>F8-4080</b>		H=95; D1=29; D2=96
Stabiliser Mounting	1.6 D	ch.32-F-390001→; ch.→32-J-290000	<b>F8-5081</b>		d=20
Stabiliser Mounting	1.3, 1.6, 1.6 D, 1.6 TD, 1.8, 1.8 Syncro, 1.9, 2.0, 2.0 Syncro, 2.1, 2.2, 2.2 Syncro		<b>F8-5225</b>		d=19
Rubber Buffer, suspension	1.3	EP	<b>F8-5673</b>		Thick. [mm]=160
Rubber Buffer, suspension	1.3, 1.6, 1.6 D, 1.6 TD, 1.8, 1.8 Syncro, 1.9, 2.0, 2.0 Syncro, 2.1, 2.2, 2.2 Syncro		<b>F8-5673</b>		Thick. [mm]=160
Engine Mounting	1.6, 1.6 D, 1.8, 1.9, 2.0, 2.1, 2.2		<b>F8-5685</b>		H=36; d=10; D=40.5
Engine Mounting	1.6, 1.6 D, 1.6 TD, 1.8		<b>F8-6834</b>		
Engine Mounting	1.9, 2.0 Syncro, 2.1, 2.2 Syncro		<b>F8-6925</b>		
Engine Mounting	2.0	ch.32-F-000001→; ch.→32-E-300000; 	<b>F8-6925</b>		
Engine Mounting	2.2	ch.→32-F-332883, 32-H-175000;	<b>F8-6925</b>		
Bellow, driveshaft	1.3	ch.→31-L-400000;  EP	<b>F8-7722</b>		d1=26; d2=78; L=110
Bellow, driveshaft	1.3, 1.6, 1.6 D, 1.6 TD, 1.8	ch.→31-L-400000	<b>F8-7722</b>		d1=26; d2=78; L=110
Bellow, driveshaft	1.9, 2.1	ch.→32-D-099297	<b>F8-7722</b>		d1=26; d2=78; L=110
Bellow, driveshaft	2.0	ch.→32-D-099297;  JS	<b>F8-7722</b>		d1=26; d2=78; L=110
Bellow, steering	All Models	with clamps	<b>LM-10026S</b>		d1=27; d2=45; L [mm]=150
Bellow, driveshaft	1.3, 1.6, 1.6 D, 1.6 TD, 1.8, 1.8 Syncro, 1.9, 2.0, 2.0 Syncro, 2.1, 2.2 Syncro		<b>M-830220</b>		
Bellow Set, drive shaft	1.3	ch.→31-L-400000;  EP	<b>MK-830220</b>		
Bellow Set, drive shaft	1.3, 1.6, 1.6 D, 1.6 TD, 1.8	ch.→31-L-400000	<b>MK-830220</b>		
Bellow Set, drive shaft	1.8 Syncro, 2.0 Syncro, 2.2 Syncro	ch.→33-H-086636	<b>MK-830220</b>		
Bellow Set, drive shaft	1.9, 2.1	ch.→32-D-099297	<b>MK-830220</b>		
Bellow Set, drive shaft	2.0	ch.→32-D-099297;  JS	<b>MK-830220</b>		

### PASSAT Saloon (32B)

08/1984 → 03/1988

Dust Cover Kit, shock absorber	1.6, 1.6 TD, 1.8, 2.2		<b>AK-732516</b>		
Dust Cover Kit, shock absorber	1.6, 1.6 TD, 1.8, 2.2		<b>AK-733023</b>		
Control Arm-/Trailing Arm Bush	1.6	without guide sleeve	<b>F8-1007</b>		H1=26; H2=41; d=17; D1=60; D2=68
Control Arm-/Trailing Arm Bush	1.6	with guide sleeve	<b>F8-1007S</b>		H1=26; H2=41; d=17; D1=60; D2=68
Mounting, axle beam	1.6, 1.6 TD, 1.8, 2.2		<b>F8-1014</b>		H1=32; H2=40; d=12; D1=44; D2=70
Engine Mounting	2.0, 2.2	ch.32F332884→	<b>F8-1020</b>		H=97; D=114; T [mm]=145
Engine Mounting	2.0, 2.2	ch.32H175001→;	<b>F8-1020</b>		H=97; D=114; T [mm]=145
Engine Mounting	2.2		<b>F8-1021</b>		H=97; D=114; T [mm]=143

<b>AK-732516</b>	<b>AK-733023</b>	<b>F8-1007</b>	<b>F8-1007S</b>	<b>F8-1014</b>	<b>F8-1020</b>	<b>F8-1021</b>
Ref.Nr.:	Ref.Nr.: 191412303	Ref.Nr.: 191407181A	Ref.Nr.: 191407181A	Ref.Nr.: 321501541	Ref.Nr.: 443199379	Ref.Nr.: 443199382
<b>F8-1026</b>	<b>F8-4080</b>	<b>F8-5081</b>	<b>F8-5225</b>	<b>F8-5673</b>	<b>F8-5685</b>	<b>F8-6834</b>
Ref.Nr.: 811407181A	Ref.Nr.: 113501149	Ref.Nr.: 811411327A	Ref.Nr.: 823411327B	Ref.Nr.: 321512131B	Ref.Nr.: 811199419A	Ref.Nr.: 823199381C
<b>F8-6925</b>	<b>F8-7722</b>	<b>LM-10026S</b>	<b>M-830220</b>	<b>MK-830220</b>		
Ref.Nr.: 443199381J	Ref.Nr.: 191407285F	Ref.Nr.: 811419831B	Ref.Nr.: 191498203C	Ref.Nr.: 171498203		

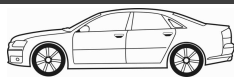

**Article Description****Article Nr.****Fitting Position**

<b>PASSAT Saloon (32B)</b>			<b>08/1984 → 03/1988</b>		
Control Arm-/Trailing Arm Bush	1.6, 1.6 TD, 1.8, 2.2		<b>F8-1026</b>		H=44; d=10; D1=38; D2=48
Top Strut Mounting	1.6, 1.6 TD, 1.8, 2.2		<b>F8-1027</b>		H=37; d1=14; d2=20; D=76
Stabiliser Mounting	1.6, 1.6 TD, 1.8, 2.2		<b>F8-1029</b>		H=42; Thick. [mm]=25; W=38
Stabiliser Mounting	1.8		<b>F8-1029</b>		H=42; Thick. [mm]=25; W=38
Engine Mounting	1.6, 1.6 TD, 1.8		<b>F8-1031</b>		H=47; d=10; D1=38; D2=52
Engine Mounting	1.6, 1.6 TD, 1.8, 2.2		<b>F8-1032</b>		D=10; H=42; D1=38; D2=46
Engine Mounting	1.6, 1.6 TD, 1.8		<b>F8-3000</b>		H=60; Thick. [mm]=66; W=89
Anti-Friction Bearing	1.6, 1.6 TD, 1.8, 2.2		<b>F8-3036</b>		
Flange, carburettor	1.6, 1.8		<b>F8-3044</b>		H=21
Flange, carburettor	1.6, 1.6 TD, 1.8, 2.0, 2.2		<b>F8-3045</b>		H=21
Flange, carburettor	1.6, 1.8		<b>F8-3047</b>		H=24
Mounting, radiator	2.0, 2.2		<b>F8-4009</b>		H1=15; H2=37; D=39; Outer Thread [mm]=M8 x 1,50
Rubber Buffer, silencer	1.8		<b>F8-4026</b>		H=12; W=57, 60
Mounting, manual transmission	1.6, 1.6 TD, 1.8		<b>F8-4030</b>		H=50; d=14; D=84
Control Arm-/Trailing Arm Bush	1.6, 1.6 TD, 1.8	ch.32-E-150001→	<b>F8-4043</b>		H=44; d=10; D1=37; D2=54
Control Arm-/Trailing Arm Bush	1.6, 1.8, 2.2		<b>F8-4043</b>		H=44; d=10; D1=37; D2=54
Rubber Buffer, suspension	1.6, 1.6 TD, 1.8, 2.2		<b>F8-4062</b>		H=67; d1=20; d2=24; D=52
Protective Cap/Bellow, shock absorber	1.6, 1.6 TD, 1.8, 2.2		<b>F8-4065</b>		H=97; d1=46; d2=76
Bellow, steering	1.6, 1.6 TD, 1.8, 2.2		<b>F8-4073</b>		H=147; D=48
Rubber Buffer, suspension	1.6, 1.6 TD, 1.8, 2.2		<b>F8-5673</b>		Thick. [mm]=160
Rubber Buffer, suspension	2.0	HP	<b>F8-5673</b>		Thick. [mm]=160
Engine Mounting	1.6, 1.8		<b>F8-5685</b>		H=36; d=10; D=40.5
Engine Mounting	1.6, 1.6 TD, 1.8		<b>F8-6834</b>		
Bellow, driveshaft	1.6, 1.6 TD, 1.8	ch.→31-L-400000	<b>F8-7722</b>		d1=26; d2=78; L=110
Bellow, driveshaft	2.0	ch.→32-D-099297	<b>F8-7722</b>		d1=26; d2=78; L=110
Bellow, steering	1.6, 1.6 TD, 1.8, 2.0, 2.2	with clamps	<b>LM-10026S</b>		d1=27; d2=45; L [mm]=150
Bellow, driveshaft	1.6, 1.6 TD, 1.8		<b>M-830220</b>		
Bellow Set, drive shaft	1.6, 1.6 TD, 1.8	ch.→31-L-400000	<b>MK-830220</b>		
Bellow Set, drive shaft	1.6, 2.2	ch.→33-H-086636	<b>MK-830220</b>		
Bellow Set, drive shaft	2.0	ch.→32-D-099297;  HP	<b>MK-830220</b>		

<b>AK-732516</b>	<b>F8-1026</b>	<b>F8-1027</b>	<b>F8-1029</b>	<b>F8-1031</b>	<b>F8-1032</b>	<b>F8-3000</b>
Ref.Nr.:	Ref.Nr.: 811407181A	Ref.Nr.: 811412323D	Ref.Nr.: 823411313A	Ref.Nr.: 811199415A	Ref.Nr.: 811199419B	Ref.Nr.: 823199381B
<b>F8-3036</b>	<b>F8-3044</b>	<b>F8-3045</b>	<b>F8-3047</b>	<b>F8-4009</b>	<b>F8-4026</b>	<b>F8-4030</b>
Ref.Nr.: 377412335A	Ref.Nr.: 026129761A	Ref.Nr.: 027129761	Ref.Nr.: 050129761C	Ref.Nr.: 431121273	Ref.Nr.: 817253147	Ref.Nr.: 811399151B
<b>F8-4043</b>	<b>F8-4062</b>	<b>F8-4065</b>	<b>F8-4073</b>	<b>F8-5673</b>	<b>F8-5685</b>	<b>F8-6834</b>
Ref.Nr.: 8A0407181	Ref.Nr.: 811412131A	Ref.Nr.: 811412135A	Ref.Nr.: 811419831B	Ref.Nr.: 321512131B	Ref.Nr.: 811199419A	Ref.Nr.: 823199381C

Article Description



Article Nr.

Fitting Position



**PASSAT (3A2, 35I)**

02/1988 → 08/1996

Dust Cover Kit, shock absorber	1.6, 1.6 TD, 1.8, 1.9 D, 1.9 TD, 1.9 TDI, 2.0, 2.0 16V, 2.8 VR6	ch.→31-P-259865;	<b>AK-732516</b>		
Dust Cover Kit, shock absorber	1.6, 1.8, 1.8 16V		<b>AK-732516</b>		
Dust Cover Kit, shock absorber	1.6, 1.6 TD, 1.8, 1.8 16V, 1.8 G60 Syncro, 1.9 D, 1.9 TD, 1.9 TDI, 2.0, 2.0 16V, 2.0 Syncro, 2.8 VR6		<b>AK-733023</b>		
Dust Cover Kit, shock absorber	1.6, 1.6 TD, 1.8, 1.9 D, 1.9 TD, 1.9 TDI, 2.0, 2.0 16V, 2.8 VR6	ch.3A-R-000001→;	<b>AK-735014</b>		
Dust Cover Kit, shock absorber	1.8 G60 Syncro, 2.0 Syncro		<b>AK-735032</b>		
Dust Cover Kit, shock absorber	2.8 VR6	ch.31M320489→	<b>AK-735032</b>		
Dust Cover Kit, shock absorber	1.8 G60 Syncro, 2.0 Syncro		<b>AK-735118</b>		
Dust Cover Kit, shock absorber	All Models	ch.31-P-026436→;	<b>AK-735410</b>		H=210
Alternator Freewheel Clutch	1.9 D, 1.9 TD, 1.9 TDI		<b>F5-1007</b>		
Engine Mounting	1.6, 1.6 TD, 1.8, 1.9 D, 1.9 TD		<b>F8-1003</b>		H=120; d=11; D=106; Thick [mm]=62, 76
Engine Mounting	1.8 16V, 2.0, 2.0 16V, 2.8 VR6		<b>F8-1003</b>		H=120; d=11; D=106; Thick [mm]=62, 76
Engine Mounting	1.6 TD, 1.9 D, 1.9 TD		<b>F8-1004</b>		H=114; D=106
Engine Mounting	1.6, 1.8, 1.8 16V		<b>F8-1004</b>		H=114; D=106
Engine Mounting	2.0	ch.→31N500000;  2E;	<b>F8-1004</b>		H=114; D=106
Engine Mounting	2.0 16V	ch.→31N500000;	<b>F8-1004</b>		H=114; D=106
Engine Mounting	1.6, 1.8		<b>F8-1005</b>		H=109; d1=6; d2=12; D=116
Control Arm-/Trailing Arm Bush	1.6, 1.6 TD, 1.8, 1.8 16V, 1.8 G60 Syncro, 1.9 D, 1.9 TD, 1.9 TDI, 2.0, 2.0 16V, 2.0 Syncro, 2.8 VR6	without guide sleeve	<b>F8-1007</b>		H1=26; H2=41; d=17; D1=60; D2=68
Control Arm-/Trailing Arm Bush	1.6, 1.6 TD, 1.8, 1.8 16V, 1.8 G60 Syncro, 1.9 D, 1.9 TD, 1.9 TDI, 2.0, 2.0 16V, 2.0 Syncro, 2.8 VR6	with guide sleeve	<b>F8-1007S</b>		H1=26; H2=41; d=17; D1=60; D2=68
Repair Kit, link	1.6, 1.6 TD, 1.8, 1.8 16V, 1.8 G60 Syncro, 1.9 D, 1.9 TD, 1.9 TDI, 2.0, 2.0 16V, 2.0 Syncro, 2.8 VR6	with guide sleeve	<b>F8-1008</b>		H1=24; H2=41; d=17; D=60
Top Strut Mounting	1.6, 1.6 TD, 1.8, 1.8 16V, 1.8 G60 Syncro, 1.9 D, 1.9 TD, 2.0, 2.0 16V, 2.0 Syncro	ch.→31-P-026435	<b>F8-1009C</b>		H1=39; H2=55; d=14; D=127
Top Strut Mounting	2.8 VR6	ch.31-M-320488→; ch.→31-M-400000	<b>F8-1009C</b>		H1=39; H2=55; d=14; D=127
Engine Mounting	1.6, 1.6 TD, 1.8, 1.9 TD		<b>F8-1015</b>		H=82; D1=55; D2=71
Mounting, axle beam	1.6, 1.6 TD, 1.8, 1.8 16V, 1.9 D, 1.9 TD, 1.9 TDI, 2.0, 2.0 16V, 2.8 VR6		<b>F8-1016</b>		H=49; d1=12; d2=17; D=56; W=95
Mounting, axle beam	1.6, 1.6 TD, 1.8, 1.8 16V, 1.9 D, 1.9 TD, 1.9 TDI, 2.0, 2.0 16V, 2.8 VR6	with add-on material	<b>F8-1016S</b>		H=49; d1=12; d2=17; D=56; W=95
Engine Mounting	1.8 16V, 2.0, 2.0 16V		<b>F8-1025</b>		H=128; D=100; W=180
Top Strut Mounting	1.6 TD, 1.8, 1.8 G60 Syncro, 1.9 D, 1.9 TD, 2.0, 2.0 16V, 2.0 Syncro	ch.31-P-026436→; 01/1993 →;	<b>F8-1034</b>		H=50; d=27; D=98
Top Strut Mounting	1.6, 1.9 TDI, 2.0, 2.0 16V, 2.8 VR6		<b>F8-1034</b>		H=50; d=27; D=98
Top Strut Mounting	1.9 TDI	ch.31-P-026436→;	<b>F8-1034</b>		H=50; d=27; D=98

<b>AK-732516</b>	<b>AK-733023</b>	<b>AK-735014</b>	<b>AK-735032</b>	<b>AK-735118</b>	<b>AK-735410</b>	<b>F5-1007</b>
Ref.Nr.:	Ref.Nr.: 191412303	Ref.Nr.:	Ref.Nr.:	Ref.Nr.:	Ref.Nr.: 1J0412303	Ref.Nr.: 028903119AQ
<b>F8-1003</b>	<b>F8-1004</b>	<b>F8-1005</b>	<b>F8-1007</b>	<b>F8-1007S</b>	<b>F8-1008</b>	<b>F8-1009C</b>
Ref.Nr.: 191199262A	Ref.Nr.: 357199279C	Ref.Nr.: 191199279E	Ref.Nr.: 191407181A	Ref.Nr.: 191407181A	Ref.Nr.: 191407181E	Ref.Nr.: 357412329
<b>F8-1015</b>	<b>F8-1016</b>	<b>F8-1016S</b>	<b>F8-1025</b>	<b>F8-1034</b>	<b>F8-1034S</b>	
Ref.Nr.: 357199402	Ref.Nr.: 333501541	Ref.Nr.: 357501541AS	Ref.Nr.: 191199262C	Ref.Nr.: 357412331A	Ref.Nr.: 7201848S1	

**Article Description****Article Nr.****Fitting Position**

<b>PASSAT (3A2, 35I)</b>			<b>02/1988 → 08/1996</b>		
Top Strut Mounting	1.6 TD, 1.8, 1.8 G60 Syncro, 1.9 D, 2.0 16V, 2.0 Syncro	ch.31-P-026436→; 01/1993 →; ☼	<b>F8-1034S</b>		H=51; d=14; D=96
Top Strut Mounting	1.6, 1.8, 1.9 TD, 1.9 TDI, 2.0, 2.0 16V, 2.8 VR6	☼	<b>F8-1034S</b>		H=51; d=14; D=96
Anti-Friction Bearing	1.6, 1.6 TD, 1.8, 1.8 16V, 1.8 G60 Syncro, 1.9 D, 1.9 TD, 2.0, 2.0 16V, 2.0 Syncro		<b>F8-3036</b>		
Anti-Friction Bearing	1.6 TD, 1.8, 1.8 G60 Syncro, 1.9 D, 1.9 TD, 2.0, 2.0 16V, 2.0 Syncro	10/1992 →	<b>F8-3039</b>		H=14; d1=14; D=45
Anti-Friction Bearing	1.6, 1.9 TDI, 2.0, 2.0 16V, 2.8 VR6		<b>F8-3039</b>		H=14; d1=14; D=45
Engine Mounting	1.8 16V, 2.0, 2.0 16V		<b>F8-3040</b>		H=116; D=111
Engine Mounting	1.8 G60 Syncro	01/1990 →	<b>F8-3040</b>		H=116; D=111
Engine Mounting	2.0 Syncro		<b>F8-3040</b>		H=116; D=111
Engine Mounting	2.0, 2.0 16V	01/1992 →;	<b>F8-3040</b>		H=116; D=111
Engine Mounting	1.6 TD, 1.8, 1.9 D, 1.9 TD	01/1992 →;	<b>F8-3041</b>		H=85; D1=69; D2=71; T [mm]=106
Engine Mounting	1.6, 1.9 TDI, 2.0		<b>F8-3041</b>		H=85; D1=69; D2=71; T [mm]=106
Engine Mounting	2.0 16V, 2.8 VR6		<b>F8-3041</b>		H=85; D1=69; D2=71; T [mm]=106
Flange, carburettor	1.6, 1.8		<b>F8-3048</b>		H=27; d=40
Engine Mounting	2.0		<b>F8-3053</b>		H=135; D1=79; D2=93
Engine Mounting	1.6		<b>F8-4016</b>		
Engine Mounting	1.9 TDI, 2.0 16V		<b>F8-4018</b>		
Clamp, silencer	1.8 G60 Syncro, 2.0 Syncro		<b>F8-4027</b>		H=17; W=53, 61
Stabiliser Mounting	1.6, 1.8, 1.8 16V, 1.8 G60 Syncro, 1.9 TD, 1.9 TDI, 2.0, 2.0 16V, 2.0 Syncro, 2.8 VR6		<b>F8-4057</b>		H=34; d=21; L=46
Stabiliser Mounting	1.6, 1.8, 1.8 16V, 1.8 G60 Syncro, 1.9 TD, 1.9 TDI, 2.0, 2.0 16V, 2.0 Syncro, 2.8 VR6		<b>F8-4058</b>		H=34; d=21; L=46
Rubber Buffer, suspension	1.6, 1.6 TD, 1.8, 1.8 16V, 1.9 D, 1.9 TD, 2.0, 2.0 16V, 2.0 Syncro		<b>F8-4063</b>		H=83; d1=18; d2=25; D1=48; D2=60
Rubber Buffer, suspension	1.8 G60 Syncro	ch.→31-P-026435	<b>F8-4063</b>		H=83; d1=18; d2=25; D1=48; D2=60
Protective Cap/Bellow, shock absorber	1.6, 1.6 TD, 1.8, 1.8 16V, 1.9 D, 1.9 TD, 1.9 TDI, 2.0, 2.0 16V	ch.→31-P-026435	<b>F8-4064</b>		H=90; d1=50; d2=71; D1=66; D2=77
Bellow, steering	1.6, 1.6 TD, 1.8, 1.8 16V, 1.9 D, 1.9 TD, 1.9 TDI, 2.0, 2.0 16V, 2.8 VR6		<b>F8-4069</b>		
Bellow, steering	1.6, 1.6 TD, 1.8, 1.8 16V, 1.8 G60 Syncro, 1.9 D, 1.9 TD, 1.9 TDI, 2.0, 2.0 16V, 2.0 Syncro, 2.8 VR6		<b>F8-4075</b>		H=200; d=10; D=48
Bellow, steering	1.6, 1.9 TDI, 2.0	for steering manufacturer: ZF;	<b>F8-4076</b>		H=151; D1=20; D2=55
Bellow, steering	1.8, 1.9 TD, 1.9 TDI, 2.0 16V, 2.0 Syncro, 2.8 VR6		<b>F8-4076</b>		H=151; D1=20; D2=55
Mounting, steering gear	1.6, 1.6 TD, 1.8, 1.8 16V, 1.9 D, 1.9 TD, 2.0, 2.0 16V, 2.8 VR6	ch.→31-N-080000;	<b>F8-5145</b>		d1=50.7; d2=48.3
Stabiliser Mounting	1.6, 1.6 TD, 1.8, 1.9 D, 1.9 TD	Saloon	<b>F8-5224</b>		d=21
Stabiliser Mounting	1.6, 1.6 TD, 1.8, 1.9 D, 1.9 TD	Saloon	<b>F8-5235</b>		d=21

<b>F8-1034S</b>	<b>F8-3036</b>	<b>F8-3039</b>	<b>F8-3040</b>	<b>F8-3041</b>	<b>F8-3048</b>	<b>F8-3053</b>
Ref.Nr.: 7201848S1	Ref.Nr.: 377412335A	Ref.Nr.: 357412249A	Ref.Nr.: 357199279	Ref.Nr.: 357199402A	Ref.Nr.: 050129761B	Ref.Nr.: 1H0199609B
<b>F8-4016</b>	<b>F8-4018</b>	<b>F8-4027</b>	<b>F8-4057</b>	<b>F8-4058</b>	<b>F8-4063</b>	<b>F8-4064</b>
Ref.Nr.: 1H0199262G	Ref.Nr.: 357199262D	Ref.Nr.: 171253147A	Ref.Nr.: 357411313A	Ref.Nr.: 357411314A	Ref.Nr.: 191412303A	Ref.Nr.: 191412135
<b>F8-4069</b>	<b>F8-4075</b>	<b>F8-4076</b>	<b>F8-5145</b>	<b>F8-5224</b>	<b>F8-5235</b>	<b>F8-5346</b>
Ref.Nr.: 171419831B	Ref.Nr.: 357422831	Ref.Nr.: 357422831B	Ref.Nr.: 191419883	Ref.Nr.: 357411314	Ref.Nr.: 357411313	Ref.Nr.: 1H0199609G

Article Description



Article Nr.

Fitting Position



**PASSAT (3A2, 35I)**

02/1988 → 08/1996

Engine Mounting	1.6	Brown	<b>F8-5346</b>		
Spring Cap	1.6, 1.6 TD, 1.8, 1.8 16V, 1.9 TD, 2.0, 2.0 16V, 2.0 Syncro		<b>F8-5360</b>		
Engine Mounting	1.9 TD		<b>F8-5377</b>		
Engine Mounting	2.0		<b>F8-5377</b>		
Engine Mounting	1.9 TDI, 2.0 16V		<b>F8-5396</b>		
Engine Mounting	1.6	1F;	<b>F8-5491</b>		
Engine Mounting	1.6, 1.6 TD, 1.8, 1.8 G60 Syncro, 1.9 TDI, 2.0, 2.0 Syncro, 2.4, 2.8 VR6		<b>F8-5491</b>		
Engine Mounting	1.8	01/1994 →;  ABS, ADZ;	<b>F8-5491</b>		
Engine Mounting	1.8 16V	ch.31-J-000001→	<b>F8-5491</b>		
Engine Mounting	1.8, 1.9 TD	01/1994 →;	<b>F8-5491</b>		
Engine Mounting	1.9 D, 2.0 16V		<b>F8-5491</b>		
Engine Mounting	2.0	2E, ADY, AGG;	<b>F8-5491</b>		
Engine Mounting	1.6	ch.31-J-000001→; ch.→3A-V-300000	<b>F8-5554</b>		H=39.5; d1=16; d2=24; D=50
Engine Mounting	1.6, 1.6 TD, 1.8, 1.8 16V, 1.8 G60 Syncro, 1.9 D, 1.9 TD, 1.9 TDI, 2.0, 2.0 16V, 2.0 Syncro, 2.8 VR6		<b>F8-5554</b>		H=39.5; d1=16; d2=24; D=50
Belt Pulley, crankshaft	1.9 TD, 1.9 TDI	ch.31-J-000001→; ch.→3A-V-300000; Number of Ribs: 5; Parameter: 6PK	<b>F8-5649</b>		H=31.5; d=30.02; Mounting points diam.[mm]=8.5; D1=161.5; D2=160.5
Protective Cap/Bellow, shock absorber	All Models	ch.31-P-026436→	<b>F8-5683</b>		H=210
Protective Cap/Bellow, shock absorber	1.6, 1.6 TD, 1.8, 1.8 16V, 1.8 G60 Syncro, 1.9 D, 1.9 TD, 1.9 TDI, 2.0, 2.0 16V, 2.4, 2.8 VR6		<b>F8-5765</b>		H=170
Rubber Buffer, suspension	1.6, 1.9 TDI, 2.0, 2.0 16V, 2.8 VR6		<b>F8-5993</b>		H=83
Rubber Buffer, suspension	1.8, 1.9 TD, 2.0, 2.0 Syncro	10/1993 →	<b>F8-5993</b>		H=83
Sleeve, control arm mounting	1.6, 1.6 TD, 1.8, 1.8 16V, 1.8 G60 Syncro, 1.9 D, 1.9 TD, 1.9 TDI, 2.0, 2.0 16V, 2.0 Syncro, 2.8 VR6		<b>F8-6699</b>		d=16; L=50; D=17
Engine Mounting	2.8 VR6		<b>F8-6717</b>		
Rubber Buffer, suspension	1.6, 1.6 TD, 1.8, 1.8 16V, 1.9 D, 1.9 TD, 2.0, 2.0 16V, 2.4, 2.8 VR6	;	<b>F8-7701</b>		H=155
Bellow, driveshaft	1.6	ch.→31-L-400000;  1F	<b>F8-7722</b>		d1=26; d2=78; L=110
Bellow, driveshaft	1.6	ch.→31-L-400000;  EZ	<b>F8-7722</b>		d1=26; d2=78; L=110
Bellow, driveshaft	1.6 TD	ch.→31-L-400000	<b>F8-7722</b>		d1=26; d2=78; L=110
Flange, carburettor	1.6		<b>F8-7743</b>		
Flange, carburettor	1.6	EZ; not for  1F	<b>F8-7743</b>		
Control Arm-/Trailing Arm Bush	1.6, 1.6 TD, 1.8, 1.8 16V, 1.8 G60 Syncro, 1.8 GL, 1.9 D, 1.9 TD, 1.9 TDI, 2.0, 2.0 16V, 2.0 Syncro, 2.4		<b>F8-7978</b>		
Control Arm-/Trailing Arm Bush	1.6, 1.6 TD, 1.8, 1.8 16V, 1.8 G60 Syncro, 1.9 D, 1.9 TD, 1.9 TDI, 2.0, 2.0 16V, 2.0 Syncro, 2.8 VR6		<b>G9-648</b>		H=54; d=12; D1=33; D2=36



**Article Description****Article Nr.****Fitting Position**

<b>PASSAT (3A2, 35I)</b>			<b>02/1988 → 08/1996</b>	
Bellow, steering	All Models	Manufacturer Restriction: TRW; with clamps;	<b>LM-10003S</b>	d1=9; d2=43; L [mm]=210
Bellow, steering	All Models	with clamps	<b>LM-10006S</b>	d1=10; d2=41; L [mm]=210
Bellow, steering	1.6, 1.6 TD, 1.8, 1.8 16V, 1.9 D, 1.9 TD, 2.0, 2.0 16V	ch.→31-N-080000; with clamps;	<b>LM-10024S</b>	d1=25; d2=41; L [mm]=120
Bellow, steering	1.6 TD, 1.8, 1.8 G60 Syncro, 1.8 GL, 1.9 D, 1.9 TD, 1.9 TDI, 2.0, 2.0 Syncro	ch.→3A-R-099264; Manufacturer Restriction: ZF; with clamps;	<b>LM-10029S</b>	d1=13; d2=45; L [mm]=138
Bellow, steering	1.6, 1.8, 1.8 16V, 1.9 TDI, 2.0, 2.0 16V, 2.0 Syncro, 2.4, 2.8 VR6	Manufacturer Restriction: ZF; with clamps;	<b>LM-10029S</b>	d1=13; d2=45; L [mm]=138
Bellow, steering	1.6, 1.6 TD, 1.8, 1.8 16V, 1.9 D, 1.9 TD, 2.0, 2.0 16V	ch.→31-N-080000; with clamps;	<b>LM-10050S</b>	d1=25; d2=39; L [mm]=126
Bellow, driveshaft	1.6, 1.6 TD, 2.0 Syncro		<b>M-830220</b>	
Bellow Set, drive shaft	1.6	ch.→31-L-400000;  1F	<b>MK-830220</b>	
Bellow Set, drive shaft	1.6, 1.6 TD	ch.→31-L-400000	<b>MK-830220</b>	
Bellow Set, drive shaft	1.6, 1.8, 1.9 TD, 1.9 TDI, 2.0, 2.0 16V, 2.8 VR6		<b>MK-830220</b>	
Bellow Set, drive shaft	2.0 Syncro	2E, ADY, AGG	<b>MK-830220</b>	
<b>PASSAT Variant (3A5, 35I)</b>			<b>02/1988 → 05/1997</b>	
Dust Cover Kit, shock absorber	1.6, 1.6 TD, 1.8, 1.8 16V, 1.8 G60 Syncro, 1.9 D, 1.9 TD, 1.9 TDI, 2.0, 2.0 16V, 2.0 Syncro, 2.8 VR6		<b>AK-733023</b>	
Dust Cover Kit, shock absorber	1.6, 1.6 TD, 1.8, 1.8 16V, 1.9 D, 1.9 TD, 1.9 TDI, 2.0, 2.0 16V, 2.8 VR6		<b>AK-735014</b>	
Dust Cover Kit, shock absorber	1.8 G60 Syncro, 2.0 Syncro, 2.9 VR6 Syncro		<b>AK-735032</b>	
Dust Cover Kit, shock absorber	2.8 VR6	ch.31-P-026436→	<b>AK-735032</b>	
Dust Cover Kit, shock absorber	1.8 G60 Syncro, 2.0 Syncro, 2.9 VR6 Syncro		<b>AK-735118</b>	
Dust Cover Kit, shock absorber	All Models	ch.31-P-026436→; <b>ST</b>	<b>AK-735410</b>	H=210
Alternator Freewheel Clutch	1.9 D, 1.9 TD, 1.9 TDI		<b>F5-1007</b>	
Engine Mounting	1.6, 1.6 TD, 1.8, 1.9 D, 1.9 TD		<b>F8-1003</b>	H=120; d=11; D=106; Thick. [mm]=62, 76
Engine Mounting	1.8 16V, 2.0, 2.0 16V, 2.8 VR6		<b>F8-1003</b>	H=120; d=11; D=106; Thick. [mm]=62, 76
Engine Mounting	1.6 TD, 1.9 D, 1.9 TD		<b>F8-1004</b>	H=114; D=106
Engine Mounting	1.6, 1.8, 1.8 16V		<b>F8-1004</b>	H=114; D=106
Engine Mounting	2.0	ch.→31N500000;  2E;	<b>F8-1004</b>	H=114; D=106
Engine Mounting	2.0 16V	ch.→31N500000;	<b>F8-1004</b>	H=114; D=106
Engine Mounting	1.6, 1.8		<b>F8-1005</b>	H=109; d1=6; d2=12; D=116
Control Arm-/Trailing Arm Bush	1.6, 1.6 TD, 1.8, 1.8 16V, 1.9 D, 1.9 TD, 1.9 TDI, 2.0, 2.0 16V, 2.8 VR6	without guide sleeve	<b>F8-1007</b>	H1=26; H2=41; d=17; D1=60; D2=68
Control Arm-/Trailing Arm Bush	1.8 G60 Syncro, 2.0 Syncro, 2.9 VR6 Syncro	ch.→3A-V-300000; without guide sleeve	<b>F8-1007</b>	H1=26; H2=41; d=17; D1=60; D2=68
Control Arm-/Trailing Arm Bush	1.6, 1.6 TD, 1.8, 1.8 16V, 1.9 D, 1.9 TD, 1.9 TDI, 2.0, 2.0 16V, 2.8 VR6	with guide sleeve	<b>F8-1007S</b>	H1=26; H2=41; d=17; D1=60; D2=68



Article Description



Article Nr.

Fitting Position



**PASSAT Variant (3A5, 35I)**

02/1988 → 05/1997

Control Arm-/Trailing Arm Bush	1.8 G60 Syncro, 2.0 Syncro, 2.9 VR6 Syncro	ch.→3A-V-300000; with guide sleeve	<b>F8-1007S</b>		H1=26; H2=41; d=17; D1=60; D2=68
Repair Kit, link	1.6, 1.6 TD, 1.8, 1.8 16V, 1.8 G60 Syncro, 1.9 D, 1.9 TD, 1.9 TDI, 2.0, 2.0 16V, 2.0 Syncro, 2.8 VR6, 2.9 VR6 Syncro	with guide sleeve	<b>F8-1008</b>		H1=24; H2=41; d=17; D=60
Top Strut Mounting	1.6, 1.6 TD, 1.8, 1.8 16V, 1.8 G60 Syncro, 1.9 D, 1.9 TD, 2.0, 2.0 16V, 2.0 Syncro	ch.→31-P-026435	<b>F8-1009C</b>		H1=39; H2=55; d=14; D=127
Top Strut Mounting	2.8 VR6	ch.31-M-320488→; ch.→31-M-400000	<b>F8-1009C</b>		H1=39; H2=55; d=14; D=127
Engine Mounting	1.6, 1.6 TD, 1.8, 1.9 TD		<b>F8-1015</b>		H=82; D1=55; D2=71
Mounting, axle beam	1.6, 1.6 TD, 1.8, 1.8 16V, 1.9 D, 1.9 TD, 1.9 TDI, 2.0, 2.0 16V, 2.8 VR6		<b>F8-1016</b>		H=49; d1=12; d2=17; D=56; W=95
Mounting, axle beam	1.6, 1.6 TD, 1.8, 1.8 16V, 1.9 D, 1.9 TD, 1.9 TDI, 2.0, 2.0 16V, 2.8 VR6	with add-on material	<b>F8-1016S</b>		H=49; d1=12; d2=17; D=56; W=95
Engine Mounting	1.8 16V, 2.0, 2.0 16V		<b>F8-1025</b>		H=128; D=100; W=180
Top Strut Mounting	1.6 TD, 1.8, 1.8 G60 Syncro, 1.9 D, 1.9 TD, 2.0, 2.0 16V, 2.0 Syncro	ch.31-P-026436→; 01/1993 →;	<b>F8-1034</b>		H=50; d=27; D=98
Top Strut Mounting	1.6, 1.9 TDI, 2.0, 2.0 16V, 2.8 VR6, 2.9 VR6 Syncro		<b>F8-1034</b>		H=50; d=27; D=98
Top Strut Mounting	1.9 TDI	ch.31-P-026436→;	<b>F8-1034</b>		H=50; d=27; D=98
Top Strut Mounting	1.6 TD, 1.8 G60 Syncro, 1.9 D, 2.0 16V	ch.31-P-026436→; 01/1993 →;	<b>F8-1034S</b>		H=51; d=14; D=96
Top Strut Mounting	1.6, 1.8, 1.9 TD, 1.9 TDI, 2.0, 2.0 16V, 2.0 Syncro, 2.8 VR6, 2.9 VR6 Syncro		<b>F8-1034S</b>		H=51; d=14; D=96
Anti-Friction Bearing	1.6, 1.6 TD, 1.8, 1.8 16V, 1.8 G60 Syncro, 1.9 D, 1.9 TD, 2.0, 2.0 16V, 2.0 Syncro		<b>F8-3036</b>		
Anti-Friction Bearing	1.6 TD, 1.8, 1.8 G60 Syncro, 1.9 D, 1.9 TD, 2.0, 2.0 Syncro	10/1992 →	<b>F8-3039</b>		H=14; d1=14; D=45
Anti-Friction Bearing	1.6, 1.9 TDI, 2.0, 2.0 16V, 2.8 VR6, 2.9 VR6 Syncro		<b>F8-3039</b>		H=14; d1=14; D=45
Engine Mounting	1.8 16V, 2.0, 2.0 16V		<b>F8-3040</b>		H=116; D=111
Engine Mounting	1.8 G60 Syncro	01/1990 →	<b>F8-3040</b>		H=116; D=111
Engine Mounting	2.0 Syncro		<b>F8-3040</b>		H=116; D=111
Engine Mounting	2.0, 2.0 16V	01/1992 →;	<b>F8-3040</b>		H=116; D=111
Engine Mounting	1.6 TD, 1.8, 1.9 D, 1.9 TD	01/1992 →;	<b>F8-3041</b>		H=85; D1=69; D2=71; T [mm]=106
Engine Mounting	1.6, 1.9 TDI, 2.0		<b>F8-3041</b>		H=85; D1=69; D2=71; T [mm]=106
Engine Mounting	2.0 16V, 2.0 Syncro, 2.8 VR6, 2.9 VR6 Syncro		<b>F8-3041</b>		H=85; D1=69; D2=71; T [mm]=106
Flange, carburettor	1.6, 1.8		<b>F8-3048</b>		H=27; d=40
Engine Mounting	2.0, 2.0 Syncro		<b>F8-3053</b>		H=135; D1=79; D2=93
Engine Mounting	1.6		<b>F8-4016</b>		
Engine Mounting	1.9 TDI, 2.0 16V, 2.0 Syncro		<b>F8-4018</b>		
Clamp, silencer	1.8 G60 Syncro, 2.0 Syncro, 2.9 VR6 Syncro		<b>F8-4027</b>		H=17; W=53, 61



**Article Description****Article Nr.****Fitting Position**

<b>PASSAT Variant (3A5, 35I)</b>			<b>02/1988 → 05/1997</b>		
Stabiliser Mounting	1.6, 1.6 TD, 1.8, 1.8 16V, 1.8 G60 Syncro, 1.9 D, 1.9 TD, 1.9 TDI, 2.0, 2.0 16V, 2.0 Syncro, 2.8 VR6, 2.9 VR6 Syncro		<b>F8-4057</b>		H=34; d=21; L=46
Stabiliser Mounting	1.6, 1.6 TD, 1.8, 1.8 16V, 1.8 G60 Syncro, 1.9 D, 1.9 TD, 1.9 TDI, 2.0, 2.0 16V, 2.0 Syncro, 2.8 VR6, 2.9 VR6 Syncro		<b>F8-4058</b>		H=34; d=21; L=46
Rubber Buffer, suspension	1.6, 1.6 TD, 1.8, 1.8 16V, 1.8 G60 Syncro, 1.9 D, 2.0, 2.0 16V		<b>F8-4063</b>		H=83; d1=18; d2=25; D1=48; D2=60
Rubber Buffer, suspension	1.6, 1.9 TD	ch.→31-P-026435	<b>F8-4063</b>		H=83; d1=18; d2=25; D1=48; D2=60
Rubber Buffer, suspension	2.0 Syncro	ch.→31-P-026435;	<b>F8-4063</b>		H=83; d1=18; d2=25; D1=48; D2=60
Protective Cap/Bellow, shock absorber	1.6, 1.6 TD, 1.8, 1.8 16V, 1.9 D, 1.9 TD, 1.9 TDI, 2.0, 2.0 16V	ch.→31-P-026435	<b>F8-4064</b>		H=90; d1=50; d2=71; D1=66; D2=77
Bellow, steering	1.6, 1.6 TD, 1.8, 1.8 16V, 1.9 D, 1.9 TD, 1.9 TDI, 2.0, 2.0 16V, 2.8 VR6		<b>F8-4069</b>		
Bellow, steering	1.6, 1.6 TD, 1.8, 1.8 16V, 1.8 G60 Syncro, 1.9 D, 1.9 TD, 1.9 TDI, 2.0, 2.0 16V, 2.0 Syncro, 2.8 VR6, 2.9 VR6 Syncro		<b>F8-4075</b>		H=200; d=10; D=48
Bellow, steering	1.6, 2.0, 2.9 VR6 Syncro	for steering manufacturer: ZF;	<b>F8-4076</b>		H=151; D1=20; D2=55
Bellow, steering	1.8, 1.9 TDI, 2.0 16V		<b>F8-4076</b>		H=151; D1=20; D2=55
Bellow, steering	2.8 VR6	ch.→3A-R-099264; for steering manufacturer: TRW;	<b>F8-4076</b>		H=151; D1=20; D2=55
Mounting, steering gear	1.6, 1.6 TD, 1.8, 1.8 16V, 1.9 D, 1.9 TD, 2.0, 2.0 16V, 2.8 VR6	ch.→31-N-080000;	<b>F8-5145</b>		d1=50.7; d2=48.3
Stabiliser Mounting	1.6, 1.6 TD, 1.8, 1.9 TD	Saloon	<b>F8-5224</b>		d=21
Stabiliser Mounting	1.6, 1.6 TD, 1.8, 1.9 TD	Saloon	<b>F8-5235</b>		d=21
Engine Mounting	1.6	Brown	<b>F8-5346</b>		
Spring Cap	1.6, 1.6 TD, 1.8, 1.8 16V, 1.9 TD, 2.0, 2.0 16V, 2.0 Syncro		<b>F8-5360</b>		
Engine Mounting	1.9 TD		<b>F8-5377</b>		
Engine Mounting	2.0		<b>F8-5377</b>		
Engine Mounting	1.9 TDI		<b>F8-5396</b>		
Engine Mounting	1.9 TDI, 2.0 16V		<b>F8-5396</b>		
Engine Mounting	1.6, 1.6 TD, 1.8, 1.8 G60 Syncro, 1.9 D, 1.9 TD, 1.9 TDI, 2.0, 2.0 Syncro, 2.8 VR6		<b>F8-5491</b>		
Engine Mounting	1.6, 2.0 16V		<b>F8-5491</b>		
Engine Mounting	1.8 16V	ch.31-J-000001→	<b>F8-5491</b>		
Engine Mounting	1.6, 1.6 TD, 1.8, 1.8 16V, 1.8 G60 Syncro, 1.9 TD, 1.9 TDI, 2.0, 2.0 16V, 2.0 Syncro, 2.8 VR6, 2.9 VR6 Syncro		<b>F8-5554</b>		H=39.5; d1=16; d2=24; D=50
Engine Mounting	1.9 D	ch.31-J-000001→; ch.→3A-V-300000	<b>F8-5554</b>		H=39.5; d1=16; d2=24; D=50

<b>F8-4057</b>	<b>F8-4058</b>	<b>F8-4063</b>	<b>F8-4064</b>	<b>F8-4069</b>	<b>F8-4075</b>	<b>F8-4076</b>
Ref.Nr.: 357411313A	Ref.Nr.: 357411314A	Ref.Nr.: 191412303A	Ref.Nr.: 191412135	Ref.Nr.: 171419831B	Ref.Nr.: 357422831	Ref.Nr.: 357422831B
<b>F8-5145</b>	<b>F8-5224</b>	<b>F8-5235</b>	<b>F8-5346</b>	<b>F8-5360</b>	<b>F8-5377</b>	<b>F8-5396</b>
Ref.Nr.: 191419883	Ref.Nr.: 357411314	Ref.Nr.: 357411313	Ref.Nr.: 1H0199609G	Ref.Nr.: 191412341	Ref.Nr.: 357199262A	Ref.Nr.: 1H0199609J
<b>F8-5491</b>	<b>F8-5554</b>	<b>F8-5649</b>				
Ref.Nr.: 357199381	Ref.Nr.: 191199233	Ref.Nr.: 028105243T				

Article Description



Article Nr.

Fitting Position



**PASSAT Variant (3A5, 35I)**

02/1988 → 05/1997

Belt Pulley, crankshaft	1.9 D	Number of Ribs: 5; Parameter: 6PK	<b>F8-5649</b>		H=31.5; d=30.02; Mounting points diam.[mm]=8.5; D1=161.5; D2=160.5
Belt Pulley, crankshaft	1.9 TD, 1.9 TDI	ch.31-J-000001 →; ch.→3A-V-300000; Number of Ribs: 5; Parameter: 6PK	<b>F8-5649</b>		H=31.5; d=30.02; Mounting points diam.[mm]=8.5; D1=161.5; D2=160.5
Protective Cap/Bellow, shock absorber	All Models	ch.31-P-026436 →	<b>F8-5683</b>		H=210
Protective Cap/Bellow, shock absorber	1.6, 1.6 TD, 1.8, 1.8 16V, 1.8 G60 Syncro, 1.9 D, 1.9 TD, 1.9 TDI, 2.0, 2.0 16V, 2.0 Syncro, 2.8 VR6, 2.9 VR6 Syncro		<b>F8-5765</b>		H=170
Rubber Buffer, suspension	1.6, 1.9 TDI, 2.0, 2.0 16V		<b>F8-5993</b>		H=83
Rubber Buffer, suspension	1.8, 1.8 G60 Syncro, 1.9 TD, 2.0	10/1993 →	<b>F8-5993</b>		H=83
Sleeve, control arm mounting	1.6, 1.6 TD, 1.8, 1.8 16V, 1.8 G60 Syncro, 1.9 TD, 1.9 TDI, 2.0, 2.0 16V, 2.0 Syncro, 2.8 VR6, 2.9 VR6 Syncro		<b>F8-6699</b>		d=16; L=50; D=17
Engine Mounting	2.8 VR6, 2.9 VR6 Syncro		<b>F8-6717</b>		
Bellow, driveshaft	1.6	ch.→31-L-400000;  1F	<b>F8-7722</b>		d1=26; d2=78; L=110
Bellow, driveshaft	1.6, 1.6 TD	ch.→31-L-400000	<b>F8-7722</b>		d1=26; d2=78; L=110
Flange, carburettor	1.6		<b>F8-7743</b>		
Flange, carburettor	1.6	EZ; not for  1F	<b>F8-7743</b>		
Control Arm-/Trailing Arm Bush	1.6, 1.6 TD, 1.8, 1.8 16V, 1.8 G60 Syncro, 1.9 D, 1.9 TD, 1.9 TDI, 2.0, 2.0 16V, 2.0 Syncro, 2.8 VR6, 2.9 VR6 Syncro		<b>G9-648</b>		H=54; d=12; D1=33; D2=36
Bellow, steering	All Models	Manufacturer Restriction: TRW; with clamps;	<b>LM-10003S</b>		d1=9; d2=43; L [mm]=210
Bellow, steering	All Models	with clamps	<b>LM-10006S</b>		d1=10; d2=41; L [mm]=210
Bellow, steering	1.6, 1.6 TD, 1.8, 1.8 16V, 1.9 D, 2.0, 2.0 16V	ch.→31-N-080000; with clamps;	<b>LM-10024S</b>		d1=25; d2=41; L [mm]=120
Bellow, steering	1.6, 1.8, 1.8 16V, 1.9 TDI, 2.0, 2.0 16V, 2.0 Syncro, 2.8 VR6, 2.9 VR6 Syncro	Manufacturer Restriction: ZF; with clamps;	<b>LM-10029S</b>		d1=13; d2=45; L [mm]=138
Bellow, steering	1.8, 1.8 G60 Syncro, 1.9 TD, 1.9 TDI, 2.0, 2.0 Syncro	ch.→3A-R-099264; Manufacturer Restriction: ZF; with clamps;	<b>LM-10029S</b>		d1=13; d2=45; L [mm]=138
Bellow, steering	1.6, 1.6 TD, 1.8, 1.8 16V, 1.9 D, 2.0, 2.0 16V	ch.→31-N-080000; with clamps;	<b>LM-10050S</b>		d1=25; d2=39; L [mm]=126
Bellow, driveshaft	1.6, 1.6 TD, 2.0 Syncro, 2.9 VR6 Syncro		<b>M-830220</b>		
Bellow Set, drive shaft	1.6	ch.→31-L-400000;  1F	<b>MK-830220</b>		
Bellow Set, drive shaft	1.6, 1.6 TD	ch.→31-L-400000	<b>MK-830220</b>		
Bellow Set, drive shaft	2.0 Syncro	2E, ADY, AGG	<b>MK-830220</b>		
Bellow Set, drive shaft	2.9 VR6 Syncro		<b>MK-830220</b>		

**PASSAT (3B2)**

08/1996 → 11/2000

Dust Cover Kit, shock absorber	1.6, 1.8, 1.8 T, 1.9 TDI, 2.0, 2.3 VR5, 2.8 V6	ch.→3B-YE121221	<b>AK-735101</b>		
--------------------------------	--	-----------------	------------------	--	--

<b>AK-735101</b>	<b>AK-735127</b>	<b>F8-5649</b>	<b>F8-5683</b>	<b>F8-5765</b>	<b>F8-5993</b>	<b>F8-6699</b>
Ref.Nr.: 4D0412137C	Ref.Nr.:	Ref.Nr.: 028105243T	Ref.Nr.: 357413175A	Ref.Nr.: 333513425	Ref.Nr.: 357412303F	Ref.Nr.: 191407190A
<b>F8-6717</b>	<b>F8-7722</b>	<b>F8-7743</b>	<b>G9-648</b>	<b>LM-10003S</b>	<b>LM-10006S</b>	<b>LM-10024S</b>
Ref.Nr.: 1H0199609D	Ref.Nr.: 191407285F	Ref.Nr.: 037129761	Ref.Nr.: 357407182	Ref.Nr.: 357422831A	Ref.Nr.: 1H0422831B	Ref.Nr.: 171419831B
<b>LM-10029S</b>	<b>LM-10050S</b>	<b>M-830220</b>	<b>MK-830220</b>			
Ref.Nr.: 1H0422831A	Ref.Nr.: 171419831C	Ref.Nr.: 191498203C	Ref.Nr.: 171498203			



**Article Description****Article Nr.****Fitting Position**

<b>PASSAT (3B2)</b>		<b>08/1996 → 11/2000</b>	
Dust Cover Kit, shock absorber	1.6, 1.8, 1.8 T, 1.9 TDI, 2.0, 2.3 VR5, 2.5 TDI, 2.8 V6		<b>AK-735127</b>
Alternator Freewheel Clutch	1.6, 1.8, 1.8 Syncro/4motion, 1.8 T Syncro		<b>F5-1002</b>
Alternator Freewheel Clutch	1.9 TDI, 1.9 TDI 4motion		<b>F5-1004</b>
Alternator Freewheel Clutch	1.6, 1.8, 1.8 Syncro/4motion, 1.8 T Syncro, 1.9 TDI, 1.9 TDI 4motion, 1.9 TDI Syncro/4motion		<b>F5-1006</b>
Alternator Freewheel Clutch	1.9 TDI, 1.9 TDI Syncro/4motion		<b>F5-1007</b>
Alternator Freewheel Clutch	1.9 TDI, 1.9 TDI Syncro/4motion		<b>F5-1008</b>
Alternator Freewheel Clutch	2.3 VR5, 2.3 VR5 Syncro/4motion		<b>F5-1013</b>
Alternator Freewheel Clutch	2.3 VR5, 2.3 VR5 Syncro/4motion		<b>F5-1016</b>
Top Strut Mounting	1.6, 1.8, 1.8 Syncro/4motion, 1.8 T, 1.9 TDI, 1.9 TDI Syncro/4motion, 2.3 VR5, 2.8 V6, 2.8 V6 Syncro/4motion	ch.3B-V-000001→; 01/1997 →	<b>F8-3050</b>
Top Strut Mounting	1.8, 1.8 T Syncro, 1.9 TDI, 1.9 TDI 4motion, 2.0, 2.0 4motion, 2.5 TDI Syncro/4motion, 2.8 Syncro, 2.8 V6		<b>F8-3050</b>
Top Strut Mounting	1.9 TDI, 2.3 VR5 Syncro/4motion, 2.5 TDI	ch.3B-V-000001→	<b>F8-3050</b>
Engine Mounting	1.6, 1.8, 1.8 Syncro/4motion, 1.8 T, 1.9 TDI, 2.3 VR5, 2.3 VR5 Syncro/4motion, 2.8 V6, 2.8 V6 Syncro/4motion		<b>F8-4019</b>
Engine Mounting	1.9 TDI, 1.9 TDI Syncro/4motion		<b>F8-4019</b>
Control Arm-/Trailing Arm Bush	1.6, 1.8, 1.8 Syncro/4motion, 1.8 T, 1.9 TDI, 1.9 TDI Syncro/4motion, 2.3 VR5, 2.8 V6, 2.8 V6 Syncro/4motion	01/1997 →	<b>F8-4044</b>
Control Arm-/Trailing Arm Bush	1.9 TDI 4motion, 2.5 TDI Syncro/4motion	for OE: 4D0407151E	<b>F8-4044</b>
Control Arm-/Trailing Arm Bush	1.9 TDI, 2.3 VR5 Syncro/4motion, 2.5 TDI		<b>F8-4044</b>
Control Arm-/Trailing Arm Bush	1.6, 1.8, 1.8 Syncro/4motion, 1.8 T, 1.9 TDI, 1.9 TDI Syncro/4motion, 2.3 VR5, 2.8 V6, 2.8 V6 Syncro/4motion	01/1997 →	<b>F8-4045</b>
Control Arm-/Trailing Arm Bush	1.8, 1.8 T Syncro, 1.9 TDI, 2.0, 2.0 4motion, 2.3 VR5 Syncro/4motion, 2.5 TDI, 2.8 Syncro, 2.8 V6		<b>F8-4045</b>
Control Arm-/Trailing Arm Bush	1.9 TDI 4motion, 2.5 TDI Syncro/4motion	for OE: 4D0407151E	<b>F8-4045</b>
Stabiliser Mounting	1.6, 1.8, 1.8 T, 1.9 TDI, 2.3 VR5, 2.8 V6		<b>F8-5063</b>
Stabiliser Mounting	1.8 Syncro/4motion, 1.9 TDI Syncro/4motion, 2.3 VR5 Syncro/4motion, 2.8 V6 Syncro/4motion		<b>F8-5064</b>
Engine Mounting	1.8, 1.8 Syncro/4motion, 1.8 T		<b>F8-5538</b>
Control Arm-/Trailing Arm Bush	1.6, 1.8, 1.8 Syncro/4motion, 1.8 T, 1.9 TDI, 1.9 TDI Syncro/4motion, 2.3 VR5, 2.8 V6, 2.8 V6 Syncro/4motion	ch.3B-XE113735→; 07/1998 →	<b>F8-5542</b>
Control Arm-/Trailing Arm Bush	1.9 TDI, 1.9 TDI 4motion, 2.0, 2.0 4motion, 2.3 VR5 Syncro/4motion, 2.5 TDI, 2.5 TDI Syncro/4motion, 2.8 V6		<b>F8-5542</b>

<b>AK-735127</b>	<b>F5-1002</b>	<b>F5-1004</b>	<b>F5-1006</b>	<b>F5-1007</b>	<b>F5-1008</b>	<b>F5-1013</b>
Ref.Nr.:	Ref.Nr.: 038903119P	Ref.Nr.: 038903119T	Ref.Nr.: 038903119M	Ref.Nr.: 028903119AQ	Ref.Nr.: 028903119AN	Ref.Nr.: 038903119L
<b>F5-1016</b>	<b>F8-3050</b>	<b>F8-4019</b>	<b>F8-4044</b>	<b>F8-4045</b>	<b>F8-5063</b>	<b>F8-5064</b>
Ref.Nr.: 038903119L	Ref.Nr.: 4D0412377D	Ref.Nr.: 893199339	Ref.Nr.: 4D0407181H	Ref.Nr.: 4D0407182E	Ref.Nr.: 4D0411327G	Ref.Nr.: 4D0411327F
<b>F8-5538</b>	<b>F8-5542</b>	<b>F8-5565</b>				
Ref.Nr.: 8D0199382L	Ref.Nr.: 4B0407515	Ref.Nr.: 8D0199379S				

**Article Description**

**Article Nr.**
**Fitting Position**

**PASSAT (3B2)**
**08/1996 → 11/2000**

Engine Mounting	1.6, 1.8, 1.8 Syncro/4motion, 1.8 T, 1.9 TDI, 1.9 TDI Syncro/4motion, 2.3 VR5, 2.3 VR5 Syncro/4motion		<b>F8-5565</b>	⊕	
Engine Mounting	2.8 V6, 2.8 V6 Syncro/4motion		<b>F8-5567</b>	⊕ ⊕ ⊕	
Top Strut Mounting	1.6, 1.8, 1.8 T, 1.8 T Syncro, 1.9 TDI, 2.0, 2.3 VR5, 2.5 TDI, 2.8 V6		<b>F8-5572</b>	⊕ ⊕ ⊕	
Mounting, automatic transmission	1.6, 1.8, 1.8 Syncro/4motion, 1.8 T	ch.3B-X-700001→	<b>F8-5574</b>		
Mounting, automatic transmission	2.0		<b>F8-5574</b>		
Mounting, automatic transmission	1.6, 1.8	ch.8D-W-080001→; ch.→8D-X-199999	<b>F8-5575</b>	⊕ ⊕ ⊕	H=72; D=71
Mounting, automatic transmission	1.8 T, 2.3 VR5, 2.8 V6		<b>F8-5575</b>	⊕ ⊕ ⊕	H=72; D=71
Mounting, automatic transmission	1.9 TDI	ch.4B-W-056741→; ch.→4B-W-056740;  AJM	<b>F8-5575</b>	⊕ ⊕ ⊕	H=72; D=71
Mounting, automatic transmission	2.3 VR5 Syncro/4motion	ch.4B-W-056741→; ch.→4B-W-056740; Transmission Type: CVT (Stepless)	<b>F8-5575</b>	⊕ ⊕ ⊕	H=72; D=71
Mounting, automatic transmission	2.5 TDI, 2.5 TDI Syncro/4motion, 2.8 V6 Syncro/4motion	Transmission Type: CVT (Stepless)	<b>F8-5575</b>	⊕ ⊕ ⊕	H=72; D=71
Mounting, automatic transmission	2.8 V6	ACK, APR, BAU, BDH	<b>F8-5575</b>	⊕ ⊕ ⊕	H=72; D=71
Mounting, automatic transmission	2.3 VR5, 2.8 V6		<b>F8-5576</b>	⊕ ⊕	
Mounting, automatic transmission	2.5 TDI Syncro/4motion, 2.8 V6, 2.8 V6 Syncro/4motion		<b>F8-5576</b>	⊕ ⊕	
Mounting, automatic transmission	1.9 TDI		<b>F8-5577</b>	⊕	
Mounting, automatic transmission	1.9 TDI		<b>F8-5577</b>		
Mounting, automatic transmission	1.9 TDI, 1.9 TDI 4motion	Number of Gears: 5 Speed	<b>F8-5577</b>	⊕ ⊕ ↓	
Mounting, automatic transmission	1.9 TDI, 1.9 TDI Syncro/4motion		<b>F8-5577</b>	⊕	
Mounting, automatic transmission	1.9 TDI, 1.9 TDI Syncro/4motion		<b>F8-5577</b>		
Mounting, automatic transmission	2.3 VR5, 2.3 VR5 Syncro/4motion, 2.8 Syncro, 2.8 V6, 2.8 V6 Syncro/4motion		<b>F8-5577</b>	⊕ ⊕ ↓	
Mounting, automatic transmission	2.3 VR5, 2.3 VR5 Syncro/4motion, 2.8 Syncro, 2.8 V6, 2.8 V6 Syncro/4motion		<b>F8-5577</b>	⊕	
Mounting, manual transmission	1.6, 1.8, 1.8 Syncro/4motion, 1.8 T, 1.9 TDI, 1.9 TDI Syncro/4motion, 2.3 VR5, 2.3 VR5 Syncro/4motion		<b>F8-5578</b>	⊕	
Engine Mounting	1.6, 1.9 TDI, 1.9 TDI Syncro/4motion, 2.3 VR5, 2.3 VR5 Syncro/4motion		<b>F8-5579</b>	⊕	
Belt Pulley, crankshaft	1.9 TDI	ch.3B-V-000001→	<b>F8-5654</b>		
Belt Pulley, crankshaft	1.9 TDI Syncro/4motion		<b>F8-5654</b>		

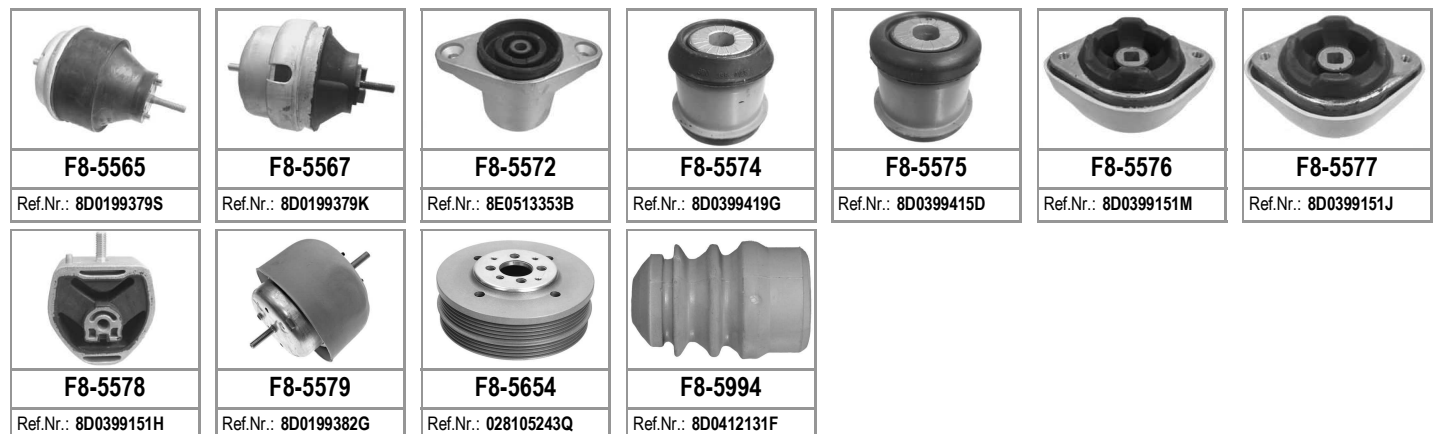

**Article Description****Article Nr.****Fitting Position**

<b>PASSAT (3B2)</b>			<b>08/1996 → 11/2000</b>		
Rubber Buffer, suspension	1.6, 1.8, 1.8 Syncro/4motion, 1.8 T, 1.8 T Syncro, 1.9 TDI, 1.9 TDI 4motion, 1.9 TDI Syncro/4motion, 2.0, 2.0 4motion, 2.3 VR5, 2.3 VR5 Syncro/4motion, 2.5 TDI, 2.5 TDI Syncro/4motion, 2.8 V6, 2.8 V6 Syncro/4motion		<b>F8-5994</b>	⊕ ⊕	H=85
Rubber Buffer, suspension	1.6, 1.8, 1.8 T, 1.9 TDI, 2.3 VR5, 2.5 TDI, 2.8 V6		<b>F8-6001</b>	⊕ ⊕	H=134
Rubber Buffer, suspension	1.6, 1.8, 1.8 Syncro/4motion, 1.8 T, 1.8 T Syncro, 1.9 TDI, 1.9 TDI 4motion, 2.0, 2.0 4motion, 2.3 VR5, 2.3 VR5 Syncro/4motion, 2.5 TDI, 2.8 V6, 2.8 V6 Syncro/4motion	<b>SP</b>	<b>F8-6003</b>	⊕ ⊕	H=103.5
Rubber Buffer, suspension	1.9 TDI Syncro/4motion	AFN; <b>SP</b>	<b>F8-6003</b>	⊕ ⊕	H=103.5
Rubber Buffer, suspension	2.5 TDI Syncro/4motion	AFB; <b>SP</b>	<b>F8-6003</b>	⊕ ⊕	H=103.5
Rubber Buffer, suspension	1.6, 1.8, 1.8 Syncro/4motion, 1.8 T, 1.8 T Syncro, 1.9 TDI, 1.9 TDI 4motion, 1.9 TDI Syncro/4motion, 2.0, 2.0 4motion, 2.3 VR5, 2.3 VR5 Syncro/4motion, 2.5 TDI, 2.5 TDI Syncro/4motion, 2.8 V6, 2.8 V6 Syncro/4motion	ch.→3BY450000;	<b>F8-6005</b>	⊕ ⊕	H=134
Rubber Buffer, suspension	1.8 Syncro/4motion, 1.9 TDI 4motion, 2.5 TDI Syncro/4motion, 2.8 V6, 2.8 V6 Syncro/4motion	<b>SP</b>	<b>F8-6039</b>	⊕ ⊕	H=77
Spring Cap	1.6, 1.8, 1.8 Syncro/4motion, 1.8 T, 1.9 TDI, 1.9 TDI 4motion, 1.9 TDI Syncro/4motion, 2.3 VR5, 2.3 VR5 Syncro/4motion, 2.5 TDI, 2.5 TDI Syncro/4motion, 2.8 V6, 2.8 V6 Syncro/4motion	ch.→3B-YE018431	<b>F8-6282</b>		
Spring Cap	1.6, 1.8, 1.8 Syncro/4motion, 1.8 T, 1.9 TDI, 1.9 TDI 4motion, 1.9 TDI Syncro/4motion, 2.0, 2.0 4motion, 2.3 VR5, 2.3 VR5 Syncro/4motion, 2.5 TDI, 2.5 TDI Syncro/4motion, 2.8 V6, 2.8 V6 Syncro/4motion	ch.3B-YE018432→	<b>F8-6283</b>		
Repair Kit, suspension strut	1.6, 1.8, 1.8 T, 1.9 TDI, 2.0, 2.3 VR5, 2.5 TDI, 2.8 V6		<b>F8-6344</b>		
Belt Pulley, crankshaft	1.9 TDI	ch.3B-V-000001→; Number of Ribs: 7	<b>F8-6391</b>		
Belt Pulley, crankshaft	1.9 TDI 4motion	ch.3B-V-000001→; Number of Ribs: 7; Type: ATJ	<b>F8-6391</b>		
Mounting, axle beam	1.6	AHL, ANA, ARM; Paired article nr: F8-6431	<b>F8-6430</b>	⊕	
Mounting, axle beam	1.8, 1.8 T, 1.9 TDI, 2.3 VR5, 2.5 TDI, 2.8 V6	Paired article nr: F8-6431	<b>F8-6430</b>	⊕	
Mounting, axle beam	2.8 V6	ACK, APR; Paired article nr: F8-6431	<b>F8-6430</b>	⊕	
Mounting, axle beam	2.8 V6	ATX; Paired article nr: F8-6431	<b>F8-6430</b>	⊕	
Mounting, axle beam	1.6	AHL, ANA, ARM; Paired article nr: F8-6430	<b>F8-6431</b>	⊕	
Mounting, axle beam	1.8, 1.8 T, 1.9 TDI, 2.3 VR5, 2.5 TDI, 2.8 V6	Paired article nr: F8-6430	<b>F8-6431</b>	⊕	
Mounting, axle beam	2.8 V6	ACK, APR; Paired article nr: F8-6430	<b>F8-6431</b>	⊕	
Mounting, axle beam	2.8 V6	ATX; Paired article nr: F8-6430	<b>F8-6431</b>	⊕	
Engine Mounting	2.5 TDI, 2.5 TDI Syncro/4motion		<b>F8-6530</b>	⊕ ⊕	

<b>F8-5994</b>	<b>F8-6001</b>	<b>F8-6003</b>	<b>F8-6005</b>	<b>F8-6039</b>	<b>F8-6282</b>	<b>F8-6283</b>
Ref.Nr.: 8D0412131F	Ref.Nr.: 3B0512131H	Ref.Nr.: 4B0512131B	Ref.Nr.: 4B0512131N	Ref.Nr.: 8D0412131E	Ref.Nr.: 8D0412065	Ref.Nr.: 8D0412065E
<b>F8-6344</b>	<b>F8-6391</b>	<b>F8-6430</b>	<b>F8-6431</b>	<b>F8-6530</b>	<b>F8-6758</b>	
Ref.Nr.: 8E0513353B	Ref.Nr.: 038105243F	Ref.Nr.: 4B0501522E	Ref.Nr.: 4B0501521D	Ref.Nr.: 4B0 199 379 E	Ref.Nr.: 8D0199339E	

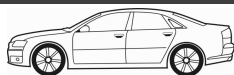
**Article Description**

**Article Nr.**
**Fitting Position**

<b>PASSAT (3B2)</b>				<b>08/1996 → 11/2000</b>	
Rubber Buffer, engine mounting	2.5 TDI, 2.5 TDI Syncro/4motion		<b>F8-6758</b>		
Repair Kit, suspension strut	1.6, 1.8, 1.8 Syncro/4motion, 1.8 T, 1.9 TDI, 1.9 TDI Syncro/4motion, 2.3 VR5, 2.3 VR5 Syncro/4motion, 2.5 TDI, 2.5 TDI Syncro/4motion, 2.8 V6, 2.8 V6 Syncro/4motion	ch.→3B-YE018431	<b>F8-7096</b>		
Repair Kit, suspension strut	1.6, 1.8, 1.8 Syncro/4motion, 1.8 T, 1.9 TDI, 1.9 TDI 4motion, 1.9 TDI Syncro/4motion, 2.0, 2.0 4motion, 2.3 VR5, 2.3 VR5 Syncro/4motion, 2.5 TDI, 2.5 TDI Syncro/4motion, 2.8 V6, 2.8 V6 Syncro/4motion	ch.3B-YE018432→	<b>F8-7097</b>		
Bellow, steering	1.6, 1.8, 1.8 Syncro/4motion, 1.8 T, 1.9 TDI, 1.9 TDI 4motion, 1.9 TDI Syncro/4motion, 2.0, 2.0 4motion, 2.3 VR5, 2.3 VR5 Syncro/4motion, 2.5 TDI, 2.5 TDI Syncro/4motion, 2.8 V6, 2.8 V6 Syncro/4motion	for vehicles with steering damper	<b>F8-7148</b>		H=141; d1=65; d2=65
Protective Cap/Bellow, shock absorber	1.6, 1.8, 1.8 Syncro/4motion, 1.8 T, 1.8 T Syncro, 1.9 TDI, 1.9 TDI 4motion, 1.9 TDI Syncro/4motion, 2.0, 2.3 VR5, 2.3 VR5 Syncro/4motion, 2.5 TDI, 2.5 TDI Syncro/4motion, 2.8 Syncro, 2.8 V6, 2.8 V6 Syncro/4motion		<b>F8-7687</b>		H=80
Protective Cap/Bellow, shock absorber	1.6, 1.8, 1.8 Syncro/4motion, 1.8 T, 1.9 TDI, 1.9 TDI Syncro/4motion, 2.0, 2.3 VR5, 2.3 VR5 Syncro/4motion, 2.5 TDI, 2.5 TDI Syncro/4motion, 2.8 V6	ch.3B-Y-450001→; for OE: 1BB, 1BF;	<b>F8-7802</b>		H=156
Mounting, automatic transmission	1.6	4-speed	<b>F8-8012</b>		H=66; D=71
Mounting, automatic transmission	1.9 TDI	AFN;  5-speed	<b>F8-8012</b>		H=66; D=71
Mounting, automatic transmission	1.9 TDI	AHU;  5-speed	<b>F8-8012</b>		H=66; D=71
Mounting, automatic transmission	2.8 V6, 2.8 V6 Syncro/4motion		<b>F8-8179</b>		
Suspension Kit	1.6, 1.8, 1.8 Syncro/4motion, 1.8 T, 1.9 TDI, 1.9 TDI 4motion, 1.9 TDI Syncro/4motion, 2.3 VR5, 2.3 VR5 Syncro/4motion, 2.5 TDI, 2.5 TDI Syncro/4motion, 2.8 V6, 2.8 V6 Syncro/4motion	ch.3B-VE083009, 3B-VP102593→	<b>G8-529</b>		
Control Arm-/Trailing Arm Bush	1.6, 1.8, 1.8 Syncro/4motion, 1.8 T, 1.9 TDI, 1.9 TDI Syncro/4motion, 2.3 VR5, 2.8 V6, 2.8 V6 Syncro/4motion	01/1997 →	<b>G9-615</b>		H1=66; H2=80; d=12; D=65
Control Arm-/Trailing Arm Bush	1.9 TDI, 2.3 VR5 Syncro/4motion, 2.5 TDI		<b>G9-615</b>		H1=66; H2=80; d=12; D=65
Control Arm-/Trailing Arm Bush	1.6, 1.8, 1.8 Syncro/4motion, 1.8 T, 1.9 TDI, 1.9 TDI Syncro/4motion, 2.3 VR5, 2.8 V6, 2.8 V6 Syncro/4motion	01/1997 →	<b>G9-616</b>		H1=26; H2=40; d=10; D1=24; D2=46
Control Arm-/Trailing Arm Bush	1.9 TDI 4motion	ch.→3B-VP-102593	<b>G9-616</b>		H1=26; H2=40; d=10; D1=24; D2=46
Control Arm-/Trailing Arm Bush	1.9 TDI, 2.3 VR5 Syncro/4motion, 2.5 TDI		<b>G9-616</b>		H1=26; H2=40; d=10; D1=24; D2=46

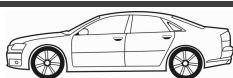
<b>F8-6758</b>	<b>F8-7096</b>	<b>F8-7097</b>	<b>F8-7148</b>	<b>F8-7687</b>	<b>F8-7802</b>	<b>F8-8012</b>
Ref.Nr.: 8D0199339E	Ref.Nr.: 8D0412065	Ref.Nr.: 8D0412065D	Ref.Nr.: 4D0419831A	Ref.Nr.: 4D0412137B	Ref.Nr.: 4B0512137B	Ref.Nr.: 8D0399415E
<b>F8-8179</b>	<b>G8-529</b>	<b>G9-615</b>	<b>G9-616</b>			
Ref.Nr.: 8D0399151R	Ref.Nr.: 8D0498998	Ref.Nr.: 4D0407183N	Ref.Nr.: 4D0407515			

**Article Description****Article Nr.****Fitting Position****PASSAT (3B2) 08/1996 → 11/2000**

Control Arm-/Trailing Arm Bush	2.5 TDI Syncro/4motion	for OE: 8D0407505B	<b>G9-616</b>		H1=26; H2=40; d=10; D1=24; D2=46
Control Arm-/Trailing Arm Bush	1.6, 1.8, 1.8 Syncro/4motion, 1.8 T, 1.9 TDI, 1.9 TDI 4motion, 1.9 TDI Syncro/4motion, 2.0, 2.0 4motion, 2.3 VR5, 2.3 VR5 Syncro/4motion, 2.5 TDI, 2.5 TDI Syncro/4motion, 2.8 V6, 2.8 V6 Syncro/4motion		<b>G9-648</b>		H=54; d=12; D1=33; D2=36
Bellow, steering	1.6, 1.8, 1.8 Syncro/4motion, 1.8 T, 1.9 TDI, 1.9 TDI Syncro/4motion, 2.3 VR5, 2.3 VR5 Syncro/4motion, 2.5 TDI, 2.5 TDI Syncro/4motion, 2.8 V6, 2.8 V6 Syncro/4motion	ch.→3B-XE376641, 3B-XP319680; with clamps;	<b>LM-10005S</b>		d1=18; d2=54; L [mm]=200
Bellow, steering	1.6, 1.8, 1.8 Syncro/4motion, 1.8 T, 1.9 TDI, 1.9 TDI Syncro/4motion, 2.3 VR5, 2.3 VR5 Syncro/4motion, 2.5 TDI, 2.5 TDI Syncro/4motion, 2.8 V6, 2.8 V6 Syncro/4motion	ch.→3B-XE376641, 3B-XP319680; with clamps;	<b>LM-10005S</b>		d1=18; d2=54; L [mm]=200
Bellow, steering	1.8 T Syncro	ch.→3B-XE376641, 3B-XP319680, 8D-X-053000; ; with clamps;	<b>LM-10005S</b>		d1=18; d2=54; L [mm]=200
Bellow, steering	2.8 Syncro	ch.→3B-XE376641, 3B-XP319680, 8D-X-053000; ; with clamps;	<b>LM-10005S</b>		d1=18; d2=54; L [mm]=200
Bellow, steering	1.6, 1.8, 1.8 Syncro/4motion, 1.8 T, 1.8 T Syncro, 1.9 TDI, 1.9 TDI Syncro/4motion	02/1999 →; ; with clamps;	<b>LM-10021S</b>		d1=20; d2=63; L [mm]=254
Bellow, steering	1.6, 1.8, 1.8 Syncro/4motion, 1.8 T, 1.8 T Syncro, 1.9 TDI, 1.9 TDI Syncro/4motion	02/1999 →; ; with clamps;	<b>LM-10021S</b>		d1=20; d2=63; L [mm]=254
Bellow, steering	1.9 TDI, 1.9 TDI 4motion, 2.0, 2.0 4motion, 2.8 V6	; with clamps;	<b>LM-10021S</b>		d1=20; d2=63; L [mm]=254
Bellow, steering	1.9 TDI, 1.9 TDI 4motion, 2.0, 2.0 4motion, 2.8 V6	; with clamps;	<b>LM-10021S</b>		d1=20; d2=63; L [mm]=254
Bellow, steering	2.3 VR5, 2.3 VR5 Syncro/4motion, 2.5 TDI, 2.5 TDI Syncro/4motion, 2.8 Syncro, 2.8 V6, 2.8 V6 Syncro/4motion	07/1999 →; ; with clamps;	<b>LM-10021S</b>		d1=20; d2=63; L [mm]=254
Bellow, steering	2.3 VR5, 2.3 VR5 Syncro/4motion, 2.5 TDI, 2.5 TDI Syncro/4motion, 2.8 Syncro, 2.8 V6, 2.8 V6 Syncro/4motion	07/1999 →; ; with clamps;	<b>LM-10021S</b>		d1=20; d2=63; L [mm]=254

**PASSAT Variant (3B5) 05/1997 → 11/2000**

Dust Cover Kit, shock absorber	1.6, 1.8, 1.8 Syncro/4motion, 1.8 T, 1.9 TDI, 1.9 TDI 4motion, 1.9 TDI Syncro/4motion, 2.0, 2.0 4motion, 2.3 VR5, 2.3 VR5 Syncro/4motion, 2.5 TDI, 2.5 TDI Syncro/4motion, 2.8 V6, 2.8 V6 Syncro/4motion		<b>AK-735101</b>		
Dust Cover Kit, shock absorber	1.6, 1.8, 1.8 T, 1.9 TDI, 2.0, 2.3 VR5, 2.5 TDI, 2.8 V6		<b>AK-735127</b>		
Alternator Freewheel Clutch	1.6, 1.8, 1.8 Syncro/4motion, 1.8 T		<b>F5-1002</b>		
Alternator Freewheel Clutch	1.9 TDI		<b>F5-1004</b>		
Alternator Freewheel Clutch	1.6, 1.8, 1.8 Syncro/4motion, 1.8 T, 1.9 TDI, 1.9 TDI 4motion, 1.9 TDI Syncro/4motion		<b>F5-1006</b>		
Alternator Freewheel Clutch	1.9 TDI, 1.9 TDI Syncro/4motion		<b>F5-1008</b>		
Alternator Freewheel Clutch	2.3 VR5, 2.3 VR5 Syncro/4motion		<b>F5-1013</b>		
Alternator Freewheel Clutch	2.3 VR5, 2.3 VR5 Syncro/4motion		<b>F5-1016</b>		

<b>AK-735101</b>	<b>AK-735127</b>	<b>F5-1002</b>	<b>F5-1004</b>	<b>F5-1006</b>	<b>F5-1008</b>	<b>F5-1013</b>
Ref.Nr.: 4D0412137C	Ref.Nr.:	Ref.Nr.: 038903119P	Ref.Nr.: 038903119T	Ref.Nr.: 038903119M	Ref.Nr.: 028903119AN	Ref.Nr.: 038903119L
<b>F5-1016</b>	<b>F8-3050</b>	<b>G9-616</b>	<b>G9-648</b>	<b>LM-10005S</b>	<b>LM-10021S</b>	
Ref.Nr.: 038903119L	Ref.Nr.: 4D0412377D	Ref.Nr.: 4D0407515	Ref.Nr.: 357407182	Ref.Nr.: 4D0419831B	Ref.Nr.: 8D0419831K	

Article Description

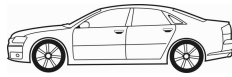

Article Nr.

Fitting Position



**PASSAT Variant (3B5)**

05/1997 → 11/2000

Top Strut Mounting	1.6, 1.8, 1.8 Syncro/4motion, 1.8 T, 1.9 TDI, 1.9 TDI Syncro/4motion, 2.3 VR5, 2.3 VR5 Syncro/4motion, 2.5 TDI, 2.8 V6, 2.8 V6 Syncro/4motion	ch.3B-V-000001→	<b>F8-3050</b>		H=37; d=12; D1=72; D2=86
Top Strut Mounting	1.8, 1.9 TDI, 1.9 TDI 4motion, 2.0, 2.0 4motion, 2.5 TDI Syncro/4motion, 2.8 Syncro, 2.8 V6		<b>F8-3050</b>		H=37; d=12; D1=72; D2=86
Engine Mounting	1.6, 1.8, 1.8 Syncro/4motion, 1.8 T, 1.9 TDI, 2.3 VR5, 2.3 VR5 Syncro/4motion, 2.8 V6, 2.8 V6 Syncro/4motion		<b>F8-4019</b>		H=47; d=26; D1=48; D2=67
Engine Mounting	1.9 TDI, 1.9 TDI Syncro/4motion		<b>F8-4019</b>		H=47; d=26; D1=48; D2=67
Control Arm-/Trailing Arm Bush	1.6, 1.8, 1.8 Syncro/4motion, 1.8 T, 1.9 TDI, 1.9 TDI Syncro/4motion, 2.3 VR5, 2.3 VR5 Syncro/4motion, 2.5 TDI, 2.8 V6, 2.8 V6 Syncro/4motion		<b>F8-4044</b>		H1=42; H2=50; d=12; D1=22; D2=40
Control Arm-/Trailing Arm Bush	1.9 TDI 4motion, 2.5 TDI Syncro/4motion	for OE: 4D0407151E	<b>F8-4044</b>		H1=42; H2=50; d=12; D1=22; D2=40
Control Arm-/Trailing Arm Bush	1.6, 1.8, 1.8 Syncro/4motion, 1.8 T, 1.9 TDI, 1.9 TDI Syncro/4motion, 2.0, 2.0 4motion, 2.3 VR5, 2.3 VR5 Syncro/4motion, 2.5 TDI, 2.8 Syncro, 2.8 V6, 2.8 V6 Syncro/4motion		<b>F8-4045</b>		H1=31; H2=60; d=12; D=50
Control Arm-/Trailing Arm Bush	1.9 TDI 4motion, 2.5 TDI Syncro/4motion	for OE: 4D0407151E	<b>F8-4045</b>		H1=31; H2=60; d=12; D=50
Stabiliser Mounting	1.6, 1.8, 1.8 Syncro/4motion, 1.8 T, 1.9 TDI, 1.9 TDI Syncro/4motion, 2.3 VR5, 2.3 VR5 Syncro/4motion, 2.8 V6, 2.8 V6 Syncro/4motion		<b>F8-5064</b>		H=44; d=27
Engine Mounting	1.8, 1.8 Syncro/4motion, 1.8 T		<b>F8-5538</b>		
Control Arm-/Trailing Arm Bush	1.6, 1.8, 1.8 Syncro/4motion, 1.8 T, 1.9 TDI, 1.9 TDI 4motion, 1.9 TDI Syncro/4motion, 2.0, 2.0 4motion, 2.3 VR5, 2.3 VR5 Syncro/4motion, 2.5 TDI, 2.5 TDI Syncro/4motion, 2.8 V6, 2.8 V6 Syncro/4motion		<b>F8-5542</b>		H=40; d=10; D=46
Engine Mounting	1.6, 1.8, 1.8 Syncro/4motion, 1.8 T, 1.9 TDI, 1.9 TDI Syncro/4motion, 2.3 VR5, 2.3 VR5 Syncro/4motion		<b>F8-5565</b>		
Engine Mounting	2.8 Syncro, 2.8 V6, 2.8 V6 Syncro/4motion		<b>F8-5567</b>		
Top Strut Mounting	1.6, 1.8, 1.8 T, 1.9 TDI, 2.0, 2.3 VR5, 2.5 TDI, 2.8 V6		<b>F8-5572</b>		
Mounting, automatic transmission	1.6, 1.8, 1.8 Syncro/4motion, 1.8 T	ch.3B-X-700001→	<b>F8-5574</b>		
Mounting, automatic transmission	2.0		<b>F8-5574</b>		
Mounting, automatic transmission	1.6, 1.8, 1.8 T, 2.5 TDI Syncro/4motion, 2.8 V6, 2.8 V6 Syncro/4motion		<b>F8-5575</b>		H=72; D=71
Mounting, automatic transmission	1.9 TDI	ch.4B-W-056741→; ch.→4B-W-056740;  AJM; Transmission Type: CVT (Stepless)	<b>F8-5575</b>		H=72; D=71
Mounting, automatic transmission	2.3 VR5	BAU, BDH	<b>F8-5575</b>		H=72; D=71
Mounting, automatic transmission	2.3 VR5 Syncro/4motion	5-speed,  5-speed	<b>F8-5575</b>		H=72; D=71



**Article Description****Article Nr.****Fitting Position**

<b>PASSAT Variant (3B5)</b>			<b>05/1997 → 11/2000</b>		
Mounting, automatic transmission	2.5 TDI	ch.→4B-W-056740	<b>F8-5575</b>	⊕ ⊕ ⊕	H=72; D=71
Mounting, automatic transmission	2.5 TDI	ch.4B-W-056741→	<b>F8-5575</b>	⊕ ⊕ ⊕	H=72; D=71
Mounting, automatic transmission	2.8 V6	ACK, APR	<b>F8-5575</b>	⊕ ⊕ ⊕	H=72; D=71
Mounting, automatic transmission	2.3 VR5, 2.8 V6		<b>F8-5576</b>	⊕ ⊕	
Mounting, automatic transmission	2.5 TDI Syncro/4motion, 2.8 V6, 2.8 V6 Syncro/4motion		<b>F8-5576</b>	⊕ ⊕	
Mounting, automatic transmission	1.9 TDI	Number of Gears: 5 Speed	<b>F8-5577</b>	⊕ ⊕ ↓	
Mounting, automatic transmission	1.9 TDI		<b>F8-5577</b>		
Mounting, automatic transmission	1.9 TDI, 1.9 TDI Syncro/4motion		<b>F8-5577</b>	⊕	
Mounting, automatic transmission	2.3 VR5, 2.3 VR5 Syncro/4motion, 2.8 V6, 2.8 V6 Syncro/4motion		<b>F8-5577</b>	⊕ ⊕ ↓	
Mounting, automatic transmission	2.3 VR5, 2.3 VR5 Syncro/4motion, 2.8 V6, 2.8 V6 Syncro/4motion		<b>F8-5577</b>	⊕	
Mounting, automatic transmission	2.8 Syncro	ch.→4BX100001	<b>F8-5577</b>	⊕ ⊕ ↓	
Mounting, manual transmission	1.6, 1.8, 1.8 Syncro/4motion, 1.8 T, 1.9 TDI, 1.9 TDI Syncro/4motion, 2.3 VR5, 2.3 VR5 Syncro/4motion		<b>F8-5578</b>	⊕	
Engine Mounting	1.6, 1.9 TDI, 1.9 TDI Syncro/4motion, 2.3 VR5, 2.3 VR5 Syncro/4motion		<b>F8-5579</b>	⊕	
Belt Pulley, crankshaft	1.9 TDI	ch.3B-V-000001→	<b>F8-5654</b>		
Belt Pulley, crankshaft	1.9 TDI Syncro/4motion		<b>F8-5654</b>		
Rubber Buffer, suspension	1.6, 1.8, 1.8 Syncro/4motion, 1.8 T, 1.9 TDI, 1.9 TDI 4motion, 1.9 TDI Syncro/4motion, 2.0, 2.0 4motion, 2.3 VR5, 2.3 VR5 Syncro/4motion, 2.5 TDI, 2.5 TDI Syncro/4motion, 2.8 Syncro, 2.8 V6, 2.8 V6 Syncro/4motion		<b>F8-5994</b>	⊕ ⊕ ⊕	H=85
Rubber Buffer, suspension	1.6, 1.8, 1.8 T, 1.9 TDI, 2.3 VR5, 2.5 TDI, 2.8 Syncro, 2.8 V6		<b>F8-6001</b>	⊕ ⊕ ⊕	H=134
Rubber Buffer, suspension	1.6, 1.8, 1.8 Syncro/4motion, 1.8 T, 1.9 TDI, 1.9 TDI 4motion, 1.9 TDI Syncro/4motion, 2.3 VR5, 2.3 VR5 Syncro/4motion, 2.5 TDI, 2.8 Syncro, 2.8 V6, 2.8 V6 Syncro/4motion	<b>SP</b>	<b>F8-6003</b>	⊕ ⊕ ⊕	H=103.5
Rubber Buffer, suspension	2.0, 2.0 4motion	ASU; <b>SP</b>	<b>F8-6003</b>	⊕ ⊕ ⊕	H=103.5
Rubber Buffer, suspension	2.5 TDI Syncro/4motion	AFB; <b>SP</b>	<b>F8-6003</b>	⊕ ⊕ ⊕	H=103.5

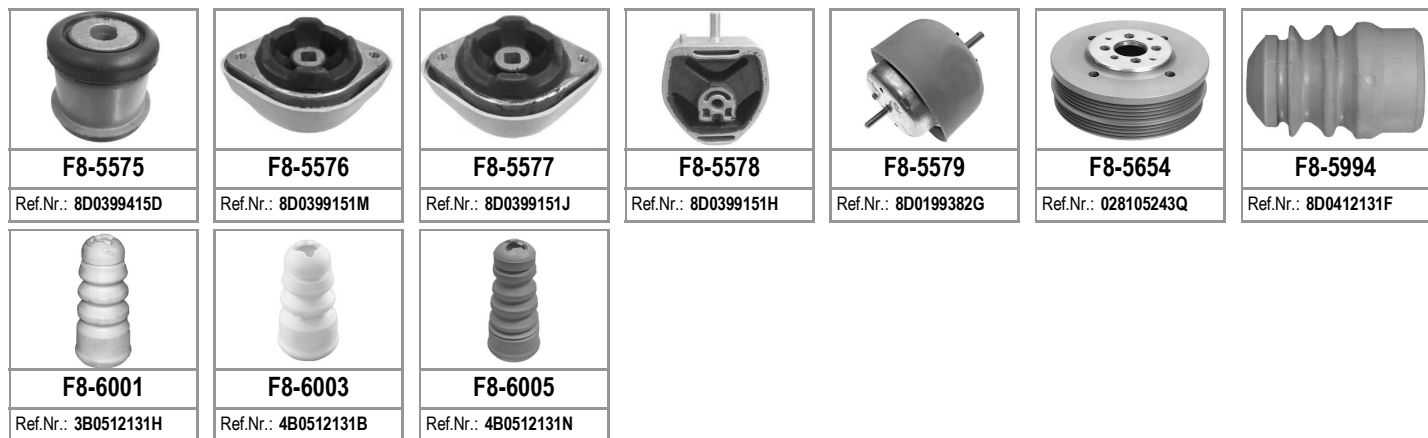

Article Description



Article Nr.

Fitting Position



<b>PASSAT Variant (3B5)</b>		<b>05/1997 → 11/2000</b>	
Rubber Buffer, suspension	1.6, 1.8, 1.8 Syncro/4motion, 1.8 T, 1.9 TDI, 1.9 TDI 4motion, 1.9 TDI Syncro/4motion, 2.0, 2.0 4motion, 2.3 VR5, 2.3 VR5 Syncro/4motion, 2.5 TDI, 2.5 TDI Syncro/4motion, 2.8 Syncro, 2.8 V6, 2.8 V6 Syncro/4motion	ch.→3BY450000; ▲	F8-6005  ⊕ ⊕ H=134
Rubber Buffer, suspension	1.9 TDI 4motion, 2.3 VR5 Syncro/4motion, 2.5 TDI Syncro/4motion, 2.8 V6 Syncro/4motion	SP	F8-6039  ⊕ ⊕ H=77
Spring Cap	1.6, 1.8, 1.8 Syncro/4motion, 1.8 T, 1.9 TDI, 1.9 TDI 4motion, 1.9 TDI Syncro/4motion, 2.3 VR5, 2.3 VR5 Syncro/4motion, 2.5 TDI, 2.5 TDI Syncro/4motion, 2.8 V6, 2.8 V6 Syncro/4motion	ch.→3B-YE018431	F8-6282
Spring Cap	1.6, 1.8, 1.8 Syncro/4motion, 1.8 T, 1.9 TDI, 1.9 TDI 4motion, 1.9 TDI Syncro/4motion, 2.0, 2.0 4motion, 2.3 VR5, 2.3 VR5 Syncro/4motion, 2.5 TDI, 2.5 TDI Syncro/4motion, 2.8 V6, 2.8 V6 Syncro/4motion	ch.3B-YE018432→	F8-6283
Repair Kit, suspension strut	1.6, 1.8, 1.8 T, 1.9 TDI, 2.0, 2.3 VR5, 2.5 TDI, 2.8 V6		F8-6344
Belt Pulley, crankshaft	1.9 TDI, 1.9 TDI 4motion	ch.3B-V-000001→; Number of Ribs: 7	F8-6391
Mounting, axle beam	1.6	AHL, ANA, ARM; Paired article nr: F8-6431	F8-6430  ⊕
Mounting, axle beam	1.8, 1.8 T, 1.9 TDI, 2.3 VR5, 2.5 TDI, 2.8 V6	Paired article nr: F8-6431	F8-6430  ⊕
Mounting, axle beam	2.8 V6	ACK, APR; Paired article nr: F8-6431	F8-6430  ⊕
Mounting, axle beam	1.6	AHL, ANA, ARM; Paired article nr: F8-6430	F8-6431  ⊕
Mounting, axle beam	1.8, 1.8 T, 1.9 TDI, 2.3 VR5, 2.5 TDI, 2.8 V6	Paired article nr: F8-6430	F8-6431  ⊕
Mounting, axle beam	2.8 V6	ACK, APR; Paired article nr: F8-6430	F8-6431  ⊕
Engine Mounting	2.5 TDI, 2.5 TDI Syncro/4motion		F8-6530  ⊕ ⊕
Rubber Buffer, engine mounting	2.5 TDI, 2.5 TDI Syncro/4motion		F8-6758
Repair Kit, suspension strut	1.6, 1.8, 1.8 Syncro/4motion, 1.8 T, 1.9 TDI, 1.9 TDI Syncro/4motion, 2.3 VR5, 2.3 VR5 Syncro/4motion, 2.5 TDI, 2.5 TDI Syncro/4motion, 2.8 V6, 2.8 V6 Syncro/4motion	ch.→3B-YE018431	F8-7096
Repair Kit, suspension strut	1.6, 1.8, 1.8 Syncro/4motion, 1.8 T, 1.9 TDI, 1.9 TDI 4motion, 1.9 TDI Syncro/4motion, 2.0, 2.0 4motion, 2.3 VR5, 2.3 VR5 Syncro/4motion, 2.5 TDI, 2.5 TDI Syncro/4motion, 2.8 V6, 2.8 V6 Syncro/4motion	ch.3B-YE018432→	F8-7097
Bellow, steering	1.6, 1.8, 1.8 Syncro/4motion, 1.8 T, 1.9 TDI, 1.9 TDI 4motion, 1.9 TDI Syncro/4motion, 2.0, 2.0 4motion, 2.3 VR5, 2.3 VR5 Syncro/4motion, 2.5 TDI, 2.5 TDI Syncro/4motion, 2.8 V6, 2.8 V6 Syncro/4motion	for vehicles with steering damper	F8-7148  ⊕ H=141; d1=65; d2=65
Protective Cap/Bellow, shock absorber	1.6, 1.8, 1.8 Syncro/4motion, 1.8 T, 1.9 TDI, 1.9 TDI Syncro/4motion, 2.0, 2.3 VR5, 2.3 VR5 Syncro/4motion, 2.5 TDI, 2.5 TDI Syncro/4motion, 2.8 Syncro, 2.8 V6, 2.8 V6 Syncro/4motion		F8-7687  H=80

<b>F8-6005</b>	<b>F8-6039</b>	<b>F8-6282</b>	<b>F8-6283</b>	<b>F8-6344</b>	<b>F8-6391</b>	<b>F8-6430</b>
Ref.Nr.: 4B0512131N	Ref.Nr.: 8D0412131E	Ref.Nr.: 8D0412065	Ref.Nr.: 8D0412065E	Ref.Nr.: 8E0513353B	Ref.Nr.: 038105243F	Ref.Nr.: 4B0501522E
<b>F8-6431</b>	<b>F8-6530</b>	<b>F8-6758</b>	<b>F8-7096</b>	<b>F8-7097</b>	<b>F8-7148</b>	<b>F8-7687</b>
Ref.Nr.: 4B0501521D	Ref.Nr.: 4B0 199 379 E	Ref.Nr.: 8D0199339E	Ref.Nr.: 8D0412065	Ref.Nr.: 8D0412065D	Ref.Nr.: 4D0419831A	Ref.Nr.: 4D0412137B
<b>F8-7802</b>						
Ref.Nr.: 4B0512137B						



**Article Description****Article Nr.****Fitting Position**

<b>PASSAT Variant (3B5)</b>			<b>05/1997 → 11/2000</b>		
Protective Cap/Bellow, shock absorber	1.6, 1.8, 1.8 Syncro/4motion, 1.8 T, 1.9 TDI, 1.9 TDI Syncro/4motion, 2.0, 2.3 VR5, 2.3 VR5 Syncro/4motion, 2.5 TDI, 2.5 TDI Syncro/4motion, 2.8 V6, 2.8 V6 Syncro/4motion	ch.3B-Y-450001→; for OE: 1BB, 1BF;	<b>F8-7802</b>		H=156
Mounting, automatic transmission	1.6	4-speed	<b>F8-8012</b>		H=66; D=71
Mounting, automatic transmission	1.8 T	5-speed	<b>F8-8012</b>		H=66; D=71
Mounting, automatic transmission	2.0	ASU;  4-speed	<b>F8-8012</b>		H=66; D=71
Mounting, automatic transmission	2.8 V6, 2.8 V6 Syncro/4motion		<b>F8-8179</b>		
Suspension Kit	1.6, 1.8, 1.8 Syncro/4motion, 1.8 T, 1.9 TDI, 1.9 TDI 4motion, 1.9 TDI Syncro/4motion, 2.3 VR5, 2.3 VR5 Syncro/4motion, 2.5 TDI, 2.5 TDI Syncro/4motion, 2.8 V6, 2.8 V6 Syncro/4motion	ch.3B-VE083009, 3B-VP102593→	<b>G8-529</b>		
Control Arm-/Trailing Arm Bush	1.6, 1.8, 1.8 Syncro/4motion, 1.8 T, 1.9 TDI, 1.9 TDI Syncro/4motion, 2.3 VR5, 2.3 VR5 Syncro/4motion, 2.5 TDI, 2.8 V6, 2.8 V6 Syncro/4motion		<b>G9-615</b>		H1=66; H2=80; d=12; D=65
Control Arm-/Trailing Arm Bush	1.6, 1.8, 1.8 Syncro/4motion, 1.8 T, 1.9 TDI, 1.9 TDI Syncro/4motion, 2.3 VR5, 2.3 VR5 Syncro/4motion, 2.5 TDI, 2.8 V6, 2.8 V6 Syncro/4motion		<b>G9-616</b>		H1=26; H2=40; d=10; D1=24; D2=46
Control Arm-/Trailing Arm Bush	1.9 TDI 4motion, 2.5 TDI Syncro/4motion	for OE: 8D0407505B	<b>G9-616</b>		H1=26; H2=40; d=10; D1=24; D2=46
Control Arm-/Trailing Arm Bush	1.6, 1.8, 1.8 Syncro/4motion, 1.8 T, 1.9 TDI, 1.9 TDI 4motion, 1.9 TDI Syncro/4motion, 2.0, 2.0 4motion, 2.3 VR5, 2.3 VR5 Syncro/4motion, 2.5 TDI, 2.5 TDI Syncro/4motion, 2.8 V6, 2.8 V6 Syncro/4motion		<b>G9-648</b>		H=54; d=12; D1=33; D2=36
Bellow, steering	1.6, 1.8, 1.8 Syncro/4motion, 1.8 T, 1.9 TDI, 1.9 TDI Syncro/4motion, 2.3 VR5, 2.3 VR5 Syncro/4motion, 2.5 TDI, 2.5 TDI Syncro/4motion, 2.8 V6, 2.8 V6 Syncro/4motion	ch.→3B-XE376641, 3B-XP319680; with clamps;	<b>LM-10005S</b>		d1=18; d2=54; L [mm]=200
Bellow, steering	1.6, 1.8, 1.8 Syncro/4motion, 1.8 T, 1.9 TDI, 1.9 TDI Syncro/4motion, 2.3 VR5, 2.3 VR5 Syncro/4motion, 2.5 TDI, 2.5 TDI Syncro/4motion, 2.8 V6, 2.8 V6 Syncro/4motion	ch.→3B-XE376641, 3B-XP319680; with clamps;	<b>LM-10005S</b>		d1=18; d2=54; L [mm]=200
Bellow, steering	2.8 Syncro	ch.→3B-XE376641, 3B-XP319680, 8D-X-053000; ; with clamps;	<b>LM-10005S</b>		d1=18; d2=54; L [mm]=200
Bellow, steering	1.6, 1.8, 1.8 Syncro/4motion, 1.8 T, 1.9 TDI, 1.9 TDI Syncro/4motion	02/1999 →; ; with clamps;	<b>LM-10021S</b>		d1=20; d2=63; L [mm]=254
Bellow, steering	1.6, 1.8, 1.8 Syncro/4motion, 1.8 T, 1.9 TDI, 1.9 TDI Syncro/4motion	02/1999 →; ; with clamps;	<b>LM-10021S</b>		d1=20; d2=63; L [mm]=254
Bellow, steering	1.9 TDI, 1.9 TDI 4motion, 2.0, 2.0 4motion, 2.8 V6	; with clamps;	<b>LM-10021S</b>		d1=20; d2=63; L [mm]=254
Bellow, steering	1.9 TDI, 1.9 TDI 4motion, 2.0, 2.0 4motion, 2.8 V6	; with clamps;	<b>LM-10021S</b>		d1=20; d2=63; L [mm]=254
Bellow, steering	2.3 VR5, 2.3 VR5 Syncro/4motion, 2.5 TDI, 2.5 TDI Syncro/4motion, 2.8 V6, 2.8 V6 Syncro/4motion	07/1999 →; ; with clamps;	<b>LM-10021S</b>		d1=20; d2=63; L [mm]=254

**F8-7802**

Ref.Nr.: 4B0512137B

**F8-8012**

Ref.Nr.: 8D0399415E

**F8-8179**

Ref.Nr.: 8D0399151R

**G8-529**

Ref.Nr.: 8D0498998

**G9-615**

Ref.Nr.: 4D0407183N

**G9-616**

Ref.Nr.: 4D0407515

**G9-648**

Ref.Nr.: 357407182

**LM-10005S**

Ref.Nr.: 4D0419831B

**LM-10021S**

Ref.Nr.: 8D0419831K

Article Description



Article Nr.

Fitting Position



<b>PASSAT Variant (3B5)</b>				<b>05/1997 → 11/2000</b>	
Bellow, steering	2.3 VR5, 2.3 VR5 Syncro/4motion, 2.5 TDI, 2.5 TDI Syncro/4motion, 2.8 V6, 2.8 V6 Syncro/4motion	07/1999 →; ; with clamps;	<b>LM-10021S</b>		d1=20; d2=63; L [mm]=254
<b>PASSAT (3B3)</b>				<b>11/2000 → 05/2005</b>	
Dust Cover Kit, shock absorber	1.6, 1.8 T, 1.8 T 20V, 1.9 TDI, 1.9 TDI 4motion, 2.0, 2.0 4motion, 2.0 TDI, 2.3 V5, 2.3 V5 4motion, 2.5 TDI, 2.5 TDI 4motion, 2.8 4motion, 4.0 W8 4motion		<b>AK-735101</b>		
Dust Cover Kit, shock absorber	1.6, 1.8 T, 1.8 T 20V, 1.9 TDI, 2.0, 2.0 TDI, 2.3 V5, 2.5 TDI		<b>AK-735127</b>		
Alternator Freewheel Clutch	1.6, 2.0, 2.0 4motion		<b>F5-1002</b>		
Alternator Freewheel Clutch	1.6, 1.8 T 20V, 1.8 T 4motion, 1.9 TDI, 1.9 TDI 4motion, 2.0, 2.0 4motion, 2.0 TDI		<b>F5-1006</b>		
Alternator Freewheel Clutch	2.3 V5, 2.3 V5 4motion		<b>F5-1013</b>		
Top Strut Mounting	1.6, 1.8 T, 1.8 T 20V, 1.8 T 4motion, 1.9 TDI, 1.9 TDI 4motion, 2.0, 2.0 4motion, 2.3 V5, 2.3 V5 4motion, 2.5 TDI, 2.5 TDI 4motion, 2.8 4motion, 4.0 W8 4motion	ch.→3B-1-300000	<b>F8-3050</b>		H=37; d=12; D1=72; D2=86
Control Arm-/Trailing Arm Bush	1.6, 1.9 TDI, 2.0, 2.3 V5	for OE: 4D0407151E	<b>F8-4044</b>		H1=42; H2=50; d=12; D1=22; D2=40
Control Arm-/Trailing Arm Bush	1.6, 1.9 TDI, 2.0, 2.3 V5	for OE: 4D0407151E	<b>F8-4045</b>		H1=31; H2=60; d=12; D=50
Control Arm-/Trailing Arm Bush	1.8, 1.8 T, 1.8 T 20V, 1.8 T 4motion, 1.9 TDI 4motion, 2.0, 2.0 4motion, 2.0 TDI, 2.3 V5 4motion, 2.5 TDI, 2.5 TDI 4motion, 2.8 4motion, 4.0 W8 4motion		<b>F8-4045</b>		H1=31; H2=60; d=12; D=50
Engine Mounting	1.8 T, 1.8 T 20V, 2.0, 2.0 4motion		<b>F8-5538</b>		
Control Arm-/Trailing Arm Bush	1.6, 1.8 T, 1.8 T 20V, 1.9 TDI, 1.9 TDI 4motion, 2.0, 2.0 4motion, 2.3 V5, 2.3 V5 4motion, 2.5 TDI, 2.5 TDI 4motion, 2.8 4motion, 4.0 W8 4motion		<b>F8-5542</b>		H=40; d=10; D=46
Engine Mounting	2.8 4motion		<b>F8-5567</b>		
Top Strut Mounting	1.6, 1.8 T, 1.8 T 20V, 1.9 TDI, 2.0, 2.3 V5, 2.5 TDI	ch.→3B-1-300000	<b>F8-5572</b>		
Mounting, automatic transmission	1.6, 1.8 T 20V	AWT	<b>F8-5574</b>		
Mounting, automatic transmission	2.0	AWT, AZM	<b>F8-5574</b>		
Mounting, automatic transmission	2.0 4motion, 2.8 4motion		<b>F8-5574</b>		
Mounting, automatic transmission	1.6, 1.8 T 20V, 2.0, 2.0 4motion, 2.3 V5, 2.3 V5 4motion, 2.5 TDI		<b>F8-5575</b>		H=72; D=71
Mounting, automatic transmission	2.5 TDI 4motion	BDH	<b>F8-5575</b>		H=72; D=71
Mounting, automatic transmission	2.5 TDI, 2.5 TDI 4motion	AKN	<b>F8-5575</b>		H=72; D=71
Mounting, automatic transmission	2.8 4motion	AMX	<b>F8-5575</b>		H=72; D=71
Mounting, automatic transmission	4.0 W8 4motion	BDN	<b>F8-5575</b>		H=72; D=71



**Article Description****Article Nr.****Fitting Position**

<b>PASSAT (3B3)</b>			<b>11/2000 → 05/2005</b>		
Mounting, automatic transmission	1.9 TDI, 1.9 TDI 4motion, 2.5 TDI	Number of Gears: 5 Speed	<b>F8-5577</b>	⊕ ⊕ ↓	
Mounting, automatic transmission	2.3 V5, 2.3 V5 4motion, 2.8 4motion, 4.0 W8 4motion		<b>F8-5577</b>	⊕ ⊕ ↓	
Mounting, automatic transmission	2.3 V5, 2.3 V5 4motion, 2.8 4motion, 4.0 W8 4motion		<b>F8-5577</b>	⊕	
Mounting, automatic transmission	2.5 TDI 4motion	Transmission Type: FTF, GGK	<b>F8-5577</b>	⊕ ⊕ ↓	
Rubber Buffer, suspension	1.6, 1.8 T, 1.8 T 20V, 1.8 T 4motion, 1.9 TDI, 1.9 TDI 4motion, 2.0, 2.0 4motion, 2.0 TDI, 2.3 V5, 2.3 V5 4motion, 2.5 TDI, 2.5 TDI 4motion, 2.8 4motion, 4.0 W8 4motion		<b>F8-5994</b>	⊕ ⊕	H=85
Rubber Buffer, suspension	1.6, 1.8 T 20V, 1.9 TDI, 2.0, 2.3 V5, 2.5 TDI		<b>F8-6001</b>	⊕ ⊕	H=134
Rubber Buffer, suspension	1.6, 1.8 T, 1.8 T 4motion, 1.9 TDI, 1.9 TDI 4motion, 2.0, 2.0 4motion, 2.3 V5, 2.3 V5 4motion, 2.5 TDI, 2.5 TDI 4motion, 2.8 4motion	<b>SP</b>	<b>F8-6003</b>	⊕ ⊕	H=103.5
Rubber Buffer, suspension	1.8 T 20V	AWT; <b>SP</b>	<b>F8-6003</b>	⊕ ⊕	H=103.5
Rubber Buffer, suspension	2.0	AZM; <b>SP</b>	<b>F8-6003</b>	⊕ ⊕	H=103.5
Rubber Buffer, suspension	2.0 TDI	BGW; <b>SP</b>	<b>F8-6003</b>	⊕ ⊕	H=103.5
Rubber Buffer, suspension	2.5 TDI, 2.5 TDI 4motion	AKN; <b>SP</b>	<b>F8-6003</b>	⊕ ⊕	H=103.5
Rubber Buffer, suspension	4.0 W8 4motion	BDN; <b>SP</b>	<b>F8-6003</b>	⊕ ⊕	H=103.5
Rubber Buffer, suspension	1.9 TDI 4motion, 2.0 4motion, 2.3 V5 4motion, 2.5 TDI 4motion, 2.8 4motion, 4.0 W8 4motion	<b>SP</b>	<b>F8-6039</b>	⊕ ⊕	H=77
Spring Cap	All Models		<b>F8-6283</b>		
Repair Kit, suspension strut	1.6, 1.8 T, 1.8 T 20V, 1.9 TDI, 2.0, 2.3 V5, 2.5 TDI	ch.→3B-1-300000	<b>F8-6344</b>		
Top Strut Mounting	1.6, 1.8 T, 1.8 T 20V, 1.9 TDI, 2.0, 2.0 TDI, 2.3 V5, 2.5 TDI	ch.3B-1-300001→	<b>F8-6351</b>		
Belt Pulley, crankshaft	1.9 TDI	ch.→3B5100000, 3B-5E170000; 01/2001 →; Number of Ribs: 7	<b>F8-6391</b>		
Belt Pulley, crankshaft	1.9 TDI, 1.9 TDI 4motion	ch.→3B5100000, 3B-5E170000; Number of Ribs: 7	<b>F8-6391</b>		
Mounting, axle beam	1.6, 1.8 T, 1.9 TDI, 2.0, 2.0 TDI, 2.3 V5, 2.5 TDI	Paired article nr: F8-6431	<b>F8-6430</b>	⊕	
Mounting, axle beam	1.8 T 20V	AWT; Paired article nr: F8-6431	<b>F8-6430</b>	⊕	
Mounting, axle beam	2.0	AZM; Paired article nr: F8-6431	<b>F8-6430</b>	⊕	
Mounting, axle beam	2.5 TDI	AKN; Paired article nr: F8-6431	<b>F8-6430</b>	⊕	
Mounting, axle beam	1.6, 1.8 T, 1.9 TDI, 2.0, 2.0 TDI, 2.3 V5, 2.5 TDI	Paired article nr: F8-6430	<b>F8-6431</b>	⊕	
Mounting, axle beam	1.8 T 20V	AWT; Paired article nr: F8-6430	<b>F8-6431</b>	⊕	
Mounting, axle beam	2.0	AZM; Paired article nr: F8-6430	<b>F8-6431</b>	⊕	
Mounting, axle beam	2.5 TDI	AKN; Paired article nr: F8-6430	<b>F8-6431</b>	⊕	
Engine Mounting	2.5 TDI, 2.5 TDI 4motion		<b>F8-6530</b>	⊕ ⊕	

<b>F8-5577</b>	<b>F8-5994</b>	<b>F8-6001</b>	<b>F8-6003</b>	<b>F8-6039</b>	<b>F8-6283</b>	<b>F8-6344</b>
Ref.Nr.: 8D0399151J	Ref.Nr.: 8D0412131F	Ref.Nr.: 3B0512131H	Ref.Nr.: 4B0512131B	Ref.Nr.: 8D0412131E	Ref.Nr.: 8D0412065E	Ref.Nr.: 8E0513353B
<b>F8-6351</b>	<b>F8-6391</b>	<b>F8-6430</b>	<b>F8-6431</b>	<b>F8-6530</b>	<b>F8-6573</b>	
Ref.Nr.: 3B0513353	Ref.Nr.: 038105243F	Ref.Nr.: 4B0501522E	Ref.Nr.: 4B0501521D	Ref.Nr.: 4B0 199 379 E	Ref.Nr.: 03G 105 243B	

Article Description			Article Nr.	Fitting Position	
---------------------	--	--	-------------	------------------	--

**PASSAT (3B3)** 11/2000 → 05/2005

Belt Pulley, crankshaft	1.9 TDI, 1.9 TDI 4motion, 2.0 TDI		<b>F8-6573</b>		
Bracket, stabilizer mounting	1.6, 1.8, 1.8 T, 1.8 T 4motion, 1.9 TDI, 1.9 TDI 4motion, 2.0, 2.0 4motion, 2.0 TDI, 2.3 V5, 2.3 V5 4motion, 2.5 TDI, 2.5 TDI 4motion, 2.8 4motion		<b>F8-6579</b>		
Bracket, stabilizer mounting	1.8 T 20V	AWT	<b>F8-6579</b>		
Bracket, stabilizer mounting	2.0	AZM	<b>F8-6579</b>		
Bracket, stabilizer mounting	2.5 TDI, 2.5 TDI 4motion	AKN	<b>F8-6579</b>		
Bracket, stabilizer mounting	4.0 W8 4motion	BDN	<b>F8-6579</b>		
Rubber Buffer, engine mounting	2.5 TDI, 2.5 TDI 4motion		<b>F8-6758</b>		
Engine Mounting	2.5 TDI, 2.5 TDI 4motion, 4.0 W8 4motion		<b>F8-6949</b>		
Mounting, manual transmission	2.5 TDI	6-speed	<b>F8-7048</b>		
Mounting, manual transmission	2.5 TDI 4motion	BDH;  6-speed	<b>F8-7048</b>		
Repair Kit, suspension strut	1.6, 1.8 T, 1.8 T 20V, 1.9 TDI, 1.9 TDI 4motion, 2.0, 2.0 4motion, 2.3 V5, 2.3 V5 4motion, 2.5 TDI, 2.5 TDI 4motion, 2.8 4motion	ch.→3B-1-300000	<b>F8-7097</b>		
Top Strut Mounting	1.6, 1.8 T, 1.8 T 20V, 1.8 T 4motion, 1.9 TDI, 1.9 TDI 4motion, 2.0, 2.0 4motion, 2.3 V5, 2.3 V5 4motion, 2.5 TDI, 2.5 TDI 4motion, 2.8 4motion, 4.0 W8 4motion	ch.3B-1-300001→	<b>F8-7471</b>		
Top Strut Mounting	1.8, 2.0 TDI, 2.5 TDI, 2.5 TDI 4motion		<b>F8-7471</b>		
Protective Cap/Bellow, shock absorber	1.6, 1.8 T, 1.8 T 20V, 1.8 T 4motion, 1.9 TDI, 1.9 TDI 4motion, 2.0, 2.0 4motion, 2.0 TDI, 2.3 V5, 2.3 V5 4motion, 2.5 TDI, 2.5 TDI 4motion, 2.8 4motion, 4.0 W8 4motion		<b>F8-7687</b>		H=80
Protective Cap/Bellow, shock absorber	1.6, 1.8 T 20V, 1.9 TDI, 2.0, 2.0 TDI, 2.3 V5, 2.5 TDI	for OE: 1BB, 1BF;	<b>F8-7802</b>		H=156
Mounting, manual transmission	2.5 TDI, 2.5 TDI 4motion, 4.0 W8 4motion	5-speed	<b>F8-7971</b>		
Mounting, automatic transmission	1.9 TDI	AWX;  5-speed	<b>F8-8012</b>		H=66; D=71
Mounting, automatic transmission	2.0	AZM;  5-speed	<b>F8-8012</b>		H=66; D=71
Mounting, automatic transmission	2.0 4motion	5-speed	<b>F8-8012</b>		H=66; D=71
Control Arm-/Trailing Arm Bush	1.6, 1.9 TDI, 2.0, 2.3 V5	for OE: 8D0407505B	<b>G9-616</b>		H1=26; H2=40; d=10; D1=24; D2=46
Bellow Set, drive shaft	2.0	with clamps; Transmission Type: FJP	<b>MK-810160</b>		L=116

**PASSAT Variant (3B6)** 11/2000 → 08/2005

Dust Cover Kit, shock absorber	1.6, 1.8 T 20V, 1.9 TDI, 1.9 TDI 4motion, 2.0, 2.0 4motion, 2.0 TDI, 2.3 VR5, 2.3 VR5 4motion, 2.5 TDI, 2.5 TDI 4motion, 2.8 4motion, 4.0 W8 4motion		<b>AK-735101</b>		
Dust Cover Kit, shock absorber	1.6, 1.8 T 20V, 1.9 TDI, 2.0, 2.0 TDI, 2.3 VR5, 2.5 TDI		<b>AK-735127</b>		
Alternator Freewheel Clutch	1.6, 2.0, 2.0 4motion		<b>F5-1002</b>		

<b>AK-735101</b>	<b>AK-735127</b>	<b>F5-1002</b>	<b>F5-1006</b>	<b>F8-6573</b>	<b>F8-6579</b>	<b>F8-6758</b>
Ref.Nr.: 4D0412137C	Ref.Nr.:	Ref.Nr.: 038903119P	Ref.Nr.: 038903119M	Ref.Nr.: 03G 105 243B	Ref.Nr.: 1J0 411 336 C	Ref.Nr.: 8D0199339E
<b>F8-6949</b>	<b>F8-7048</b>	<b>F8-7097</b>	<b>F8-7471</b>	<b>F8-7687</b>	<b>F8-7802</b>	<b>F8-7971</b>
Ref.Nr.: 3B7199379A	Ref.Nr.: 3B0399151	Ref.Nr.: 8D0412065D	Ref.Nr.: 3B7412377A	Ref.Nr.: 4D0412137B	Ref.Nr.: 4B0512137B	Ref.Nr.: 4B0399151M
<b>F8-8012</b>	<b>G9-616</b>	<b>MK-810160</b>				
Ref.Nr.: 8D0399415E	Ref.Nr.: 4D0407515	Ref.Nr.: 3D0 498 201				

**Article Description****Article Nr.****Fitting Position**

<b>PASSAT Variant (3B6)</b>			<b>11/2000 → 08/2005</b>		
Alternator Freewheel Clutch	1.6, 1.8 4motion, 1.8 T, 1.8 T 20V, 1.9 TDI, 1.9 TDI 4motion, 2.0, 2.0 4motion, 2.0 TDI		<b>F5-1006</b>		
Alternator Freewheel Clutch	2.3 VR5, 2.3 VR5 4motion		<b>F5-1013</b>		
Control Arm-/Trailing Arm Bush	1.6, 1.9 TDI, 2.0, 2.3 VR5	for OE: 4D0407151E	<b>F8-4044</b>		H1=42; H2=50; d=12; D1=22; D2=40
Control Arm-/Trailing Arm Bush	1.6, 1.9 TDI, 2.0, 2.3 VR5	for OE: 4D0407151E	<b>F8-4045</b>		H1=31; H2=60; d=12; D=50
Control Arm-/Trailing Arm Bush	1.8 4motion, 1.8 T, 1.8 T 20V, 1.9 TDI 4motion, 2.0, 2.0 4motion, 2.0 TDI, 2.3 VR5 4motion, 2.5 TDI, 2.5 TDI 4motion, 2.8 4motion, 4.0 W8 4motion		<b>F8-4045</b>		H1=31; H2=60; d=12; D=50
Engine Mounting	1.8 T 20V, 2.0, 2.0 4motion		<b>F8-5538</b>		
Control Arm-/Trailing Arm Bush	1.6, 1.8 T 20V, 1.9 TDI, 1.9 TDI 4motion, 2.0, 2.0 4motion, 2.3 VR5, 2.3 VR5 4motion, 2.5 TDI, 2.5 TDI 4motion, 2.8 4motion, 4.0 W8 4motion		<b>F8-5542</b>		H=40; d=10; D=46
Engine Mounting	2.8 4motion		<b>F8-5567</b>		
Mounting, automatic transmission	1.6, 1.8 T 20V, 2.0, 2.8 4motion		<b>F8-5574</b>		
Mounting, automatic transmission	2.0 4motion	ch.8D-X-200001→	<b>F8-5574</b>		
Mounting, automatic transmission	1.6, 1.8 T 20V, 2.0, 2.0 4motion, 2.3 VR5, 2.3 VR5 4motion, 2.5 TDI		<b>F8-5575</b>		H=72; D=71
Mounting, automatic transmission	2.5 TDI	AKN	<b>F8-5575</b>		H=72; D=71
Mounting, automatic transmission	2.5 TDI 4motion	AGA, AKN	<b>F8-5575</b>		H=72; D=71
Mounting, automatic transmission	2.5 TDI 4motion	BDH	<b>F8-5575</b>		H=72; D=71
Mounting, automatic transmission	2.8 4motion	AMX	<b>F8-5575</b>		H=72; D=71
Mounting, automatic transmission	4.0 W8 4motion	BDN	<b>F8-5575</b>		H=72; D=71
Mounting, automatic transmission	1.9 TDI	Number of Gears: 5 Speed	<b>F8-5577</b>		
Mounting, automatic transmission	1.9 TDI, 1.9 TDI 4motion, 2.0 TDI, 2.3 VR5, 2.5 TDI, 2.5 TDI 4motion, 2.8 4motion, 4.0 W8 4motion		<b>F8-5577</b>		
Mounting, automatic transmission	1.9 TDI, 1.9 TDI 4motion, 2.0 TDI, 2.3 VR5, 2.5 TDI, 2.5 TDI 4motion, 2.8 4motion, 4.0 W8 4motion		<b>F8-5577</b>		
Rubber Buffer, suspension	All Models		<b>F8-5994</b>		H=85
Rubber Buffer, suspension	1.6, 1.8 T 20V, 1.9 TDI, 2.0, 2.3 VR5, 2.5 TDI		<b>F8-6001</b>		H=134
Rubber Buffer, suspension	1.6, 1.8 4motion, 1.8 T, 1.8 T 20V, 1.9 TDI, 1.9 TDI 4motion, 2.0, 2.0 4motion, 2.3 VR5, 2.3 VR5 4motion, 2.5 TDI, 2.5 TDI 4motion, 2.8 4motion, 4.0 W8 4motion	SP	<b>F8-6003</b>		H=103.5



Article Description



Article Nr.

Fitting Position



**PASSAT Variant (3B6)**

11/2000 → 08/2005

Rubber Buffer, suspension	2.0 TDI	BGW; <b>SP</b>	<b>F8-6003</b>		H=103.5
Rubber Buffer, suspension	2.5 TDI, 2.5 TDI 4motion	AKN; <b>SP</b>	<b>F8-6003</b>		H=103.5
Rubber Buffer, suspension	1.9 TDI 4motion, 2.0 4motion, 2.3 VR5 4motion, 2.5 TDI 4motion, 2.8 4motion, 4.0 W8 4motion	<b>SP</b>	<b>F8-6039</b>		H=77
Spring Cap	All Models		<b>F8-6283</b>		
Top Strut Mounting	1.6, 1.8 T, 1.8 T 20V, 1.9 TDI, 2.0, 2.0 TDI, 2.3 VR5, 2.5 TDI		<b>F8-6351</b>		
Belt Pulley, crankshaft	1.9 TDI	ch.→3B5100000, 3B-5E170000; 01/2001 →; Number of Ribs: 7	<b>F8-6391</b>		
Belt Pulley, crankshaft	1.9 TDI, 1.9 TDI 4motion	ch.→3B5100000, 3B-5E170000; Number of Ribs: 7	<b>F8-6391</b>		
Mounting, axle beam	1.6, 1.8 T, 1.8 T 20V, 1.9 TDI, 2.0, 2.0 TDI, 2.3 VR5, 2.5 TDI	Paired article nr: F8-6431	<b>F8-6430</b>		
Mounting, axle beam	2.5 TDI	AKN; Paired article nr: F8-6431	<b>F8-6430</b>		
Mounting, axle beam	1.6, 1.8 T, 1.8 T 20V, 1.9 TDI, 2.0, 2.0 TDI, 2.3 VR5, 2.5 TDI	Paired article nr: F8-6430	<b>F8-6431</b>		
Mounting, axle beam	2.5 TDI	AKN; Paired article nr: F8-6430	<b>F8-6431</b>		
Engine Mounting	2.5 TDI, 2.5 TDI 4motion		<b>F8-6530</b>		
Belt Pulley, crankshaft	1.9 TDI, 1.9 TDI 4motion, 2.0 TDI		<b>F8-6573</b>		
Bracket, stabilizer mounting	1.6, 1.8 T, 1.8 T 20V, 1.9 TDI, 1.9 TDI 4motion, 2.0, 2.0 4motion, 2.0 TDI, 2.3 VR5, 2.3 VR5 4motion, 2.5 TDI, 2.5 TDI 4motion, 2.8 4motion, 4.0 W8 4motion		<b>F8-6579</b>		
Bracket, stabilizer mounting	2.5 TDI, 2.5 TDI 4motion	AKN	<b>F8-6579</b>		
Rubber Buffer, engine mounting	2.5 TDI, 2.5 TDI 4motion		<b>F8-6758</b>		
Engine Mounting	2.5 TDI, 2.5 TDI 4motion, 4.0 W8 4motion		<b>F8-6949</b>		
Mounting, manual transmission	2.5 TDI	6-speed	<b>F8-7048</b>		
Mounting, manual transmission	2.5 TDI 4motion	BDH;  6-speed	<b>F8-7048</b>		
Top Strut Mounting	All Models		<b>F8-7471</b>		
Protective Cap/Bellow, shock absorber	All Models		<b>F8-7687</b>		H=80
Protective Cap/Bellow, shock absorber	1.6, 1.8 T 20V, 1.9 TDI, 2.0, 2.0 TDI, 2.3 VR5, 2.5 TDI	for OE: 1BB, 1BF;	<b>F8-7802</b>		H=156
Mounting, manual transmission	2.5 TDI, 2.5 TDI 4motion, 4.0 W8 4motion	5-speed	<b>F8-7971</b>		
Mounting, automatic transmission	1.9 TDI	AWX;  5-speed	<b>F8-8012</b>		H=66; D=71
Mounting, automatic transmission	2.0, 2.0 4motion	5-speed	<b>F8-8012</b>		H=66; D=71
Control Arm/Trailing Arm Bush	1.6, 1.9 TDI, 2.0, 2.3 VR5	for OE: 8D0407505B	<b>G9-616</b>		H1=26; H2=40; d=10; D1=24; D2=46
Bellow Set, drive shaft	2.0	with clamps; Transmission Type: FJP	<b>MK-810160</b>		L=116

						
<b>F8-6003</b>	<b>F8-6039</b>	<b>F8-6283</b>	<b>F8-6351</b>	<b>F8-6391</b>	<b>F8-6430</b>	<b>F8-6431</b>
Ref.Nr.: 4B0512131B	Ref.Nr.: 8D0412131E	Ref.Nr.: 8D0412065E	Ref.Nr.: 3B0513353	Ref.Nr.: 038105243F	Ref.Nr.: 4B0501522E	Ref.Nr.: 4B0501521D
						
<b>F8-6530</b>	<b>F8-6573</b>	<b>F8-6579</b>	<b>F8-6758</b>	<b>F8-6949</b>	<b>F8-7048</b>	<b>F8-7471</b>
Ref.Nr.: 4B0 199 379 E	Ref.Nr.: 03G 105 243B	Ref.Nr.: 1J0 411 336 C	Ref.Nr.: 8D0199339E	Ref.Nr.: 3B7199379A	Ref.Nr.: 3B0399151	Ref.Nr.: 3B7412377A
						
<b>F8-7687</b>	<b>F8-7802</b>	<b>F8-7971</b>	<b>F8-8012</b>	<b>G9-616</b>	<b>MK-810160</b>	
Ref.Nr.: 4D0412137B	Ref.Nr.: 4B0512137B	Ref.Nr.: 4B0399151M	Ref.Nr.: 8D0399415E	Ref.Nr.: 4D0407515	Ref.Nr.: 3D0 498 201	

**Article Description****Article Nr.****Fitting Position****PASSAT (3C2)**

03/2005 → 11/2010

Dust Cover Kit, shock absorber	1.6, 1.6 FSI, 1.9 TDI, 2.0 FSI, 2.0 FSI 4motion, 2.0 TDI, 2.0 TDI 16V, 2.0 TDI 16V 4motion, 2.0 TDI 4motion, 3.2 FSI 4motion, 3.6 R36 4motion		<b>AK-735184</b>				
Dust Cover Kit, shock absorber	1.6, 1.6 FSI, 1.9 TDI, 2.0 FSI, 2.0 FSI 4motion, 2.0 TDI, 2.0 TDI 16V, 2.0 TDI 16V 4motion, 2.0 TDI 4motion, 3.2 FSI 4motion, 3.6 R36 4motion		<b>AK-735185</b>				
Dust Cover Kit, shock absorber	1.6, 1.6 FSI, 1.9 TDI, 2.0 FSI, 2.0 FSI 4motion, 2.0 TDI, 2.0 TDI 16V, 2.0 TDI 16V 4motion, 2.0 TDI 4motion, 3.2 FSI 4motion, 3.6 R36 4motion	<b>SP</b>	<b>AK-735186</b>				
Dust Cover Kit, shock absorber	1.6, 1.6 FSI, 1.9 TDI, 2.0 FSI, 2.0 FSI 4motion, 2.0 TDI, 2.0 TDI 16V, 2.0 TDI 16V 4motion, 2.0 TDI 4motion, 3.2 FSI 4motion, 3.6 R36 4motion	<b>SP</b>	<b>AK-735187</b>				
Alternator Freewheel Clutch	1.6, 1.6 TDI, 1.9 TDI, 2.0 BlueTDI, 2.0 FSI, 2.0 FSI 4motion, 2.0 TDI, 2.0 TDI 16V, 2.0 TDI 16V 4motion, 2.0 TDI 4motion, 3.2 FSI 4motion		<b>F5-1004</b>				
Alternator Freewheel Clutch	1.8 TSI, 2.0 FSI		<b>F5-1044</b>				
Alternator Freewheel Clutch	1.4 TSI, 1.4 TSI EcoFuel, 1.6 FSI		<b>F5-1064</b>				
Alternator Freewheel Clutch	3.2 FSI 4motion, 3.6 R36 4motion		<b>F5-1085</b>				
Control Arm-/Trailing Arm Bush	All Models		<b>F8-5633</b>				
Belt Pulley, crankshaft	2.0 FSI, 2.0 FSI 4motion		<b>F8-5650</b>				
Protective Cap/Bellow, shock absorber	1.4 TSI, 1.4 TSI EcoFuel, 1.6, 1.6 FSI, 1.6 TDI, 1.8 TSI, 1.9 TDI, 2.0 BlueTDI, 2.0 FSI, 2.0 FSI 4motion, 2.0 TDI, 2.0 TDI 16V, 2.0 TDI 16V 4motion, 2.0 TDI 4motion, 3.2 FSI 4motion	for OE: 1JA, 1JB, 1JC, 1JG, 1JK, 1JL, 1JR, UA0, UA5; <b>HD</b> , <b>A</b> , <b>SP</b> , <b>ST</b>	<b>F8-6044</b>				H=160
Protective Cap/Bellow, shock absorber	1.4 TSI, 1.4 TSI EcoFuel, 1.6, 1.6 FSI, 1.6 TDI, 1.8 TSI, 1.9 TDI, 2.0 BlueTDI, 2.0 FSI, 2.0 FSI 4motion, 2.0 TDI, 2.0 TDI 16V, 2.0 TDI 16V 4motion, 2.0 TDI 4motion, 3.2 FSI 4motion, 3.6 R36 4motion		<b>F8-6044</b>				H=160
Top Strut Mounting	All Models		<b>F8-6284</b>				
Belt Pulley, crankshaft	1.9 TDI, 2.0 TDI, 2.0 TDI 16V	Number of Ribs: 5; Parameter: 6PK	<b>F8-6396</b>				H=41.6; d=30; Mounting points diam.[mm]=7, 8.6; D=139.7
Control Arm-/Trailing Arm Bush	1.4 TSI, 1.6, 1.6 FSI, 1.8 TSI, 1.9 TDI, 2.0 FSI, 2.0 FSI 4motion, 2.0 TDI, 2.0 TDI 16V, 2.0 TDI 16V 4motion, 2.0 TDI 4motion, 3.2 FSI 4motion, 3.6 R36 4motion		<b>F8-6463</b>				H=64; d=12; D=60
Anti-Friction Bearing	All Models		<b>F8-6569</b>				
Top Strut Mounting	All Models		<b>F8-6570</b>				
Belt Pulley, crankshaft	1.6 TDI	Number of Ribs: 5; Parameter: 6PK	<b>F8-6572</b>				
Control Arm-/Trailing Arm Bush	1.4 TSI, 1.4 TSI EcoFuel, 1.6, 1.6 FSI, 1.6 TDI, 1.8 TSI, 1.9 TDI, 2.0 BlueTDI, 2.0 FSI, 2.0 FSI 4motion, 2.0 TDI, 2.0 TDI 16V, 2.0 TDI 16V 4motion, 2.0 TDI 4motion, 3.2 FSI 4motion, 3.6 R36 4motion	ch.→3C-B-050000; Aluminium	<b>F8-6701</b>				

<b>AK-735184</b>	<b>AK-735185</b>	<b>AK-735186</b>	<b>AK-735187</b>	<b>F5-1004</b>	<b>F5-1044</b>	<b>F5-1064</b>
Ref.Nr.: 3C0412303A	Ref.Nr.: 3C0511359	Ref.Nr.: 1K0412303F	Ref.Nr.: 3C0513425	Ref.Nr.: 038903119T	Ref.Nr.: 06B903119B	Ref.Nr.: 03C903119D
<b>F5-1085</b>	<b>F8-5633</b>	<b>F8-5650</b>	<b>F8-6044</b>	<b>F8-6284</b>	<b>F8-6396</b>	<b>F8-6463</b>
Ref.Nr.: 045903119A	Ref.Nr.: 1K0407182A	Ref.Nr.: 06A105243E	Ref.Nr.: 3C0513425	Ref.Nr.: 6N0412249C	Ref.Nr.: 03G105243	Ref.Nr.: 1K0505541B
<b>F8-6569</b>	<b>F8-6570</b>	<b>F8-6572</b>	<b>F8-6701</b>			
Ref.Nr.: 6N0412249C	Ref.Nr.: 1K0412331C	Ref.Nr.: 038105243L	Ref.Nr.: 3C0199231A			

Article Description

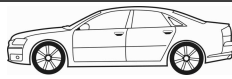

Article Nr.

Fitting Position



PASSAT (3C2)		03/2005 → 11/2010	
Control Arm-/Trailing Arm Bush	1.4 TSI, 1.4 TSI EcoFuel, 1.6, 1.6 FSI, 1.6 TDI, 1.8 TSI, 1.9 TDI, 2.0 BlueTDI, 2.0 FSI, 2.0 FSI 4motion, 2.0 TDI, 2.0 TDI 16V, 2.0 TDI 16V 4motion, 2.0 TDI 4motion, 3.2 FSI 4motion, 3.6 R36 4motion	ch.3C-B-200001→; for OE: F0A, F4F, F4G, F4J, F4Q, F5G, F6B, F6K, F6M; Aluminium; for fire brigade vehicles, for government vehicles, for police vehicles,  for vehicles for the physically handicapped, not for special purpose vehicles	<b>F8-6701</b>
Control Arm-/Trailing Arm Bush	2.0 TDI	Aluminium	<b>F8-6701</b>
Control Arm-/Trailing Arm Bush	1.4 TSI, 1.4 TSI EcoFuel, 1.6, 1.6 FSI, 1.6 TDI, 1.8 TSI, 1.9 TDI, 2.0 BlueTDI, 2.0 FSI, 2.0 FSI 4motion, 2.0 TDI, 2.0 TDI 16V, 2.0 TDI 16V 4motion, 2.0 TDI 4motion, 3.2 FSI 4motion, 3.6 R36 4motion	ch.→3C-B-050000	<b>F8-6736</b>
Control Arm-/Trailing Arm Bush	1.4 TSI, 1.4 TSI EcoFuel, 1.6, 1.6 FSI, 1.6 TDI, 1.8 TSI, 1.9 TDI, 2.0 BlueTDI, 2.0 FSI, 2.0 FSI 4motion, 2.0 TDI, 2.0 TDI 16V, 2.0 TDI 16V 4motion, 2.0 TDI 4motion, 3.2 FSI 4motion, 3.6 R36 4motion	ch.3C-B-200001→; for OE: F0A, F4F, F4G, F4J, F4Q, F5G, F6B, F6K, F6M; for fire brigade vehicles, for government vehicles, for police vehicles,  for vehicles for the physically handicapped, not for special purpose vehicles	<b>F8-6736</b>
Control Arm-/Trailing Arm Bush	2.0 TDI		<b>F8-6736</b>
Engine Mounting	1.8 TSI, 1.9 TDI, 2.0 FSI, 2.0 FSI 4motion		<b>F8-6989</b>
Engine Mounting	2.0 FSI	not for  CBFA	<b>F8-6989</b>
Engine Mounting	2.0 TDI, 2.0 TDI 16V		<b>F8-6990</b>
Engine Mounting	1.6 FSI		<b>F8-6991</b>
Engine Mounting	3.2 FSI 4motion		<b>F8-7008</b>
Rubber Buffer, suspension	1.4 TSI, 1.4 TSI EcoFuel, 1.6, 1.6 FSI, 1.8 TSI, 2.0 FSI, 2.0 FSI 4motion, 3.6 R36 4motion	for OE: G02, G05, G07, G10, G15, G16, G19; , ,	<b>F8-7131</b> H=70
Rubber Buffer, suspension	1.6 TDI, 1.9 TDI, 2.0 BlueTDI, 2.0 TDI, 2.0 TDI 16V	for OE: G07, G10, G15, G16, G19, G37; , ,	<b>F8-7131</b> H=70
Rubber Buffer, suspension	2.0 TDI	for OE: G07, G10, G15, G16; , ,	<b>F8-7131</b> H=70
Rubber Buffer, suspension	2.0 TDI 16V 4motion, 2.0 TDI 4motion	for OE: G07, G10, G15, G16, G19; , ,	<b>F8-7131</b> H=70
Rubber Buffer, suspension	3.2 FSI 4motion	for OE: G02, G05, G15, G16; , ,	<b>F8-7131</b> H=70
Protective Cap/Bellow, shock absorber	All Models		<b>F8-7132</b> H=190
Rubber Buffer, suspension	1.4 TSI, 1.4 TSI EcoFuel, 1.6, 1.6 FSI, 1.6 TDI, 1.8 TSI, 1.9 TDI, 2.0 BlueTDI, 2.0 FSI, 2.0 TDI, 2.0 TDI 16V	for OE: 1JA, 1JB, 1JG, 1JL, UA0; ,	<b>F8-7140</b> H=133
Rubber Buffer, suspension	2.0 FSI 4motion, 2.0 TDI 16V 4motion, 2.0 TDI 4motion, 3.2 FSI 4motion	for OE: 1JA, 1JB, 1JG, 1JL; ,	<b>F8-7140</b> H=133
Rubber Buffer, suspension	All Models	BlueMotion; for OE: 1K0412303M	<b>F8-7174</b> H=80

<b>F8-6701</b>	<b>F8-6736</b>	<b>F8-6989</b>	<b>F8-6990</b>	<b>F8-6991</b>	<b>F8-7008</b>	<b>F8-7131</b>
Ref.Nr.: 3C0199231A	Ref.Nr.: 1K0407183A	Ref.Nr.: 1K0199262AM	Ref.Nr.: 1K0199262P	Ref.Nr.: 1K0199262AK	Ref.Nr.: 1K0199262Q	Ref.Nr.: 1K0412303B
<b>F8-7132</b>	<b>F8-7140</b>	<b>F8-7174</b>	<b>F8-7603</b>			
Ref.Nr.: 6N0413175A	Ref.Nr.: 3C0511359	Ref.Nr.: 1K0412303M	Ref.Nr.: 3C0513353			



**Article Description****Article Nr.****Fitting Position**

<b>PASSAT (3C2)</b>		<b>03/2005 → 11/2010</b>	
Top Strut Mounting	1.4 TSI, 1.4 TSI EcoFuel, 1.6, 1.6 FSI, 1.6 TDI, 1.8 TSI, 1.9 TDI, 2.0 BlueTDI, 2.0 FSI, 2.0 FSI 4motion, 2.0 TDI, 2.0 TDI 16V, 2.0 TDI 16V 4motion, 2.0 TDI 4motion, 3.2 FSI 4motion	for OE: 1JA; <b>ST</b>	<b>F8-7603</b>
Top Strut Mounting	1.4 TSI, 1.4 TSI EcoFuel, 1.6, 1.6 FSI, 1.6 TDI, 1.8 TSI, 1.9 TDI, 2.0 BlueTDI, 2.0 FSI, 2.0 FSI 4motion, 2.0 TDI, 2.0 TDI 16V, 2.0 TDI 16V 4motion, 2.0 TDI 4motion, 3.2 FSI 4motion	for OE: 1JB, 1JL; <b>Δ</b>	<b>F8-7603</b>
Top Strut Mounting	1.4 TSI, 1.4 TSI EcoFuel, 1.6, 1.6 FSI, 1.6 TDI, 1.8 TSI, 1.9 TDI, 2.0 BlueTDI, 2.0 FSI, 2.0 FSI 4motion, 2.0 TDI, 2.0 TDI 16V, 2.0 TDI 16V 4motion, 2.0 TDI 4motion, 3.2 FSI 4motion	for OE: 1JC, 1JK; <b>SP</b>	<b>F8-7603</b>
Top Strut Mounting	1.4 TSI, 1.4 TSI EcoFuel, 1.6, 1.6 FSI, 1.6 TDI, 1.8 TSI, 1.9 TDI, 2.0 BlueTDI, 2.0 FSI, 2.0 FSI 4motion, 2.0 TDI, 2.0 TDI 16V, 2.0 TDI 16V 4motion, 2.0 TDI 4motion, 3.2 FSI 4motion	for OE: 1JR; <b>HD</b>	<b>F8-7603</b>
Top Strut Mounting	1.4 TSI, 1.4 TSI EcoFuel, 1.6, 1.6 FSI, 1.8 TSI, 1.9 TDI, 2.0 BlueTDI, 2.0 FSI, 2.0 FSI 4motion, 2.0 TDI, 2.0 TDI 16V, 2.0 TDI 16V 4motion, 2.0 TDI 4motion, 3.2 FSI 4motion, 3.6 R36 4motion		<b>F8-7603</b>
Top Strut Mounting	1.4 TSI, 1.6, 1.6 FSI, 1.6 TDI, 1.8 TSI, 1.9 TDI, 2.0 FSI, 2.0 FSI 4motion, 2.0 TDI, 2.0 TDI 16V, 2.0 TDI 16V 4motion, 2.0 TDI 4motion, 3.2 FSI 4motion	for OE: UA5; <b>■</b>	<b>F8-7603</b>
Top Strut Mounting	1.4 TSI, 1.6, 1.6 FSI, 1.6 TDI, 1.8 TSI, 1.9 TDI, 2.0 FSI, 2.0 TDI, 2.0 TDI 16V	BlueMotion; for OE: UA0	<b>F8-7603</b>
Rubber Buffer, suspension	1.4 TSI, 1.4 TSI EcoFuel, 1.6, 1.6 FSI, 1.6 TDI, 1.8 TSI, 1.9 TDI, 2.0 BlueTDI, 2.0 FSI, 2.0 FSI 4motion, 2.0 TDI, 2.0 TDI 16V, 3.2 FSI 4motion	for OE: G03, G08; <b>SP</b>	<b>F8-7697</b> H=55
Rubber Buffer, suspension	1.9 TDI, 2.0 TDI, 2.0 TDI 16V 4motion, 2.0 TDI 4motion	for OE: G08; <b>SP</b>	<b>F8-7697</b> H=55
Rubber Buffer, suspension	1.4 TSI, 1.4 TSI EcoFuel, 1.6, 1.6 FSI, 1.6 TDI, 1.8 TSI, 1.9 TDI, 2.0 BlueTDI, 2.0 FSI, 2.0 FSI 4motion, 2.0 TDI, 2.0 TDI 16V, 2.0 TDI 16V 4motion, 2.0 TDI 4motion, 3.2 FSI 4motion	for OE: 1JC; <b>SP</b>	<b>F8-7714</b> H=118
Rubber Buffer, suspension	All Models		<b>F8-7809</b> H=55
Rubber Buffer, suspension	All Models	for OE: G04, G09; <b>Δ</b>	<b>F8-7834</b> H=90
Rubber Buffer, suspension	1.4 TSI, 1.4 TSI EcoFuel, 1.6, 1.6 FSI, 1.6 TDI, 1.8 TSI, 1.9 TDI, 2.0 BlueTDI, 2.0 FSI, 2.0 FSI 4motion, 2.0 TDI, 2.0 TDI 16V, 2.0 TDI 16V 4motion, 2.0 TDI 4motion, 3.2 FSI 4motion	for OE: 1JR, UA5; <b>HD</b>	<b>F8-7836</b> H=143
Engine Mounting	1.6 TDI, 1.8 TSI, 1.9 TDI, 2.0 BlueTDI, 2.0 FSI, 2.0 FSI 4motion, 2.0 TDI, 2.0 TDI 16V, 2.0 TDI 16V 4motion, 2.0 TDI 4motion	Aluminium	<b>F8-7851</b>
Belt Pulley, crankshaft	1.8 TSI, 2.0 FSI	Number of Ribs: 5; Parameter: 6PK	<b>F8-7880</b> D=143
Control Arm-/Trailing Arm Bush	All Models		<b>F8-7902</b> H=60; d=12; D=42

<b>F8-7603</b>	<b>F8-7697</b>	<b>F8-7714</b>	<b>F8-7809</b>	<b>F8-7834</b>	<b>F8-7836</b>	<b>F8-7851</b>
Ref.Nr.: 3C0513353	Ref.Nr.: 1K0412303F	Ref.Nr.: 3C0511359B	Ref.Nr.: 1K0412303E	Ref.Nr.: 1K0412303H	Ref.Nr.: 1T0511359	Ref.Nr.: 3C0199855A
<b>F8-7880</b>	<b>F8-7902</b>	<b>F8-7907</b>				
Ref.Nr.: 06H105243F	Ref.Nr.: 1K0505171C	Ref.Nr.: 1K0505203A				

Article Description



Article Nr.

Fitting Position



<b>PASSAT (3C2)</b>		<b>03/2005 → 11/2010</b>	
Control Arm-/Trailing Arm Bush	All Models	<b>F8-7907</b>	↑
Control Arm-/Trailing Arm Bush	All Models	<b>F8-7908</b>	↑
Control Arm-/Trailing Arm Bush	All Models	<b>F8-7909</b>	↓
Stabiliser Mounting	1.6, 1.6 FSI, 2.0 FSI, 2.0 FSI 4motion	<b>F8-7923</b>	⊕ ⊕
Engine Mounting	1.4 TSI	<b>F8-7959</b>	⊕
Engine Mounting	1.6 FSI, 1.6 TDI, 1.9 TDI, 2.0 TDI	<b>F8-7963</b>	⊕
Engine Mounting	1.8 TSI	ch. → 3C-B-050000;  BZB	<b>F8-7963</b>
Engine Mounting	1.8 TSI	CDA	<b>F8-7963</b>
Engine Mounting	2.0 FSI, 2.0 FSI 4motion, 2.0 TDI	ch. → 3C-B-050000	<b>F8-7963</b>
Engine Mounting	1.6 FSI, 1.8 TSI, 2.0 FSI, 2.0 FSI 4motion	6-speed	<b>F8-7964</b>
Engine Mounting	1.8 TSI	Transmission Type: DSG	<b>F8-7964</b>
Engine Mounting	1.4 TSI EcoFuel, 1.6, 1.6 TDI, 1.8 TSI, 2.0 BlueTDI, 2.0 FSI, 2.0 FSI 4motion, 2.0 TDI, 2.0 TDI 16V, 3.2 FSI 4motion		<b>F8-7982</b>
Engine Mounting	2.0 FSI	AXX,  BPY,  BWA,  CAWB,  CCTA,  CCZA	<b>F8-7982</b>
Engine Mounting	2.0 FSI	BLR,  BLY,  BVZ	<b>F8-7982</b>
Engine Mounting	2.0 TDI	BVE	<b>F8-7982</b>
Engine Mounting	2.0 TDI	CBBB	<b>F8-7982</b>
Engine Mounting	2.0 TDI 16V 4motion, 2.0 TDI 4motion	ch. → 3C-8-055000	<b>F8-7982</b>
<b>PASSAT Variant (3C5)</b>		<b>08/2005 → 10/2011</b>	
Dust Cover Kit, shock absorber	1.6, 1.6 FSI, 1.9 TDI, 2.0 FSI, 2.0 FSI 4motion, 2.0 TDI, 2.0 TDI 16V, 2.0 TDI 16V 4motion, 2.0 TDI 4motion, 3.2 FSI 4motion, 3.6 R36 4motion	<b>AK-735184</b>	⊕ ⊕
Dust Cover Kit, shock absorber	1.6, 1.6 FSI, 1.9 TDI, 2.0 FSI, 2.0 FSI 4motion, 2.0 TDI, 2.0 TDI 16V, 2.0 TDI 16V 4motion, 2.0 TDI 4motion, 3.2 FSI 4motion, 3.6 R36 4motion	<b>AK-735185</b>	⊕ ⊕
Dust Cover Kit, shock absorber	1.6, 1.6 FSI, 1.9 TDI, 2.0 FSI, 2.0 FSI 4motion, 2.0 TDI, 2.0 TDI 16V, 2.0 TDI 16V 4motion, 2.0 TDI 4motion, 3.2 FSI 4motion, 3.6 R36 4motion	<b>AK-735186</b>	⊕ ⊕
Dust Cover Kit, shock absorber	1.6, 1.6 FSI, 1.9 TDI, 2.0 FSI, 2.0 FSI 4motion, 2.0 TDI, 2.0 TDI 16V, 2.0 TDI 16V 4motion, 2.0 TDI 4motion, 3.2 FSI 4motion, 3.6 R36 4motion	<b>AK-735187</b>	⊕ ⊕
Alternator Freewheel Clutch	1.6, 1.6 TDI, 1.9 TDI, 2.0 BlueTDI, 2.0 FSI, 2.0 FSI 4motion, 2.0 TDI, 2.0 TDI 16V, 2.0 TDI 16V 4motion, 2.0 TDI 4motion, 3.2 FSI 4motion	<b>F5-1004</b>	
Alternator Freewheel Clutch	1.8 TSI, 2.0 FSI	<b>F5-1044</b>	
Alternator Freewheel Clutch	1.4 TSI, 1.4 TSI EcoFuel, 1.6 FSI	<b>F5-1064</b>	

<b>AK-735184</b>	<b>AK-735185</b>	<b>AK-735186</b>	<b>AK-735187</b>	<b>F5-1004</b>	<b>F5-1044</b>	<b>F5-1064</b>
Ref.Nr.: 3C0412303A	Ref.Nr.: 3C0511359	Ref.Nr.: 1K0412303F	Ref.Nr.: 3C0513425	Ref.Nr.: 038903119T	Ref.Nr.: 06B903119B	Ref.Nr.: 03C903119D
<b>F5-1085</b>	<b>F8-7907</b>	<b>F8-7908</b>	<b>F8-7909</b>	<b>F8-7923</b>	<b>F8-7959</b>	<b>F8-7963</b>
Ref.Nr.: 045903119A	Ref.Nr.: 1K0505203A	Ref.Nr.: 1K0505279A	Ref.Nr.: 1K0505553 A	Ref.Nr.: 1K0511327AR	Ref.Nr.: 1K0199262CG	Ref.Nr.: 3C0199555P
<b>F8-7964</b>	<b>F8-7982</b>					
Ref.Nr.: 3C0199555Q	Ref.Nr.: 1K0199868Q					

**Article Description****Article Nr.****Fitting Position**

<b>PASSAT Variant (3C5)</b>		<b>08/2005 → 10/2011</b>	
Alternator Freewheel Clutch	3.2 FSI 4motion, 3.6 R36 4motion		<b>F5-1085</b>
Control Arm-/Trailing Arm Bush	All Models		<b>F8-5633</b>
Belt Pulley, crankshaft	2.0 FSI, 2.0 FSI 4motion		<b>F8-5650</b>
Protective Cap/Bellow, shock absorber	1.4 TSI, 1.4 TSI EcoFuel, 1.6, 1.6 FSI, 1.6 TDI, 1.8 TSI, 1.9 TDI, 2.0 BlueTDI, 2.0 FSI, 2.0 FSI 4motion, 2.0 TDI, 2.0 TDI 16V, 2.0 TDI 16V 4motion, 2.0 TDI 4motion, 3.2 FSI 4motion	for OE: 1JA, 1JB, 1JC, 1JG, 1JK, 1JL, 1JR, UA0, UA1, UA5, UA6; ☆, HD, Δ, SD, ST	<b>F8-6044</b> H=160
Protective Cap/Bellow, shock absorber	1.4 TSI, 1.4 TSI EcoFuel, 1.6, 1.6 FSI, 1.6 TDI, 1.8 TSI, 1.9 TDI, 2.0 BlueTDI, 2.0 FSI, 2.0 FSI 4motion, 2.0 TDI, 2.0 TDI 16V, 2.0 TDI 16V 4motion, 2.0 TDI 4motion, 3.2 FSI 4motion, 3.6 R36 4motion	†	<b>F8-6044</b> H=160
Top Strut Mounting	All Models		<b>F8-6284</b>
Belt Pulley, crankshaft	1.9 TDI, 2.0 TDI, 2.0 TDI 16V	Number of Ribs: 5; Parameter: 6PK	<b>F8-6396</b> H=41.6; d=30; Mounting points diam.[mm]=7, 8.6; D=139.7
Control Arm-/Trailing Arm Bush	1.4 TSI, 1.6, 1.6 FSI, 1.8 TSI, 1.9 TDI, 2.0 FSI, 2.0 FSI 4motion, 2.0 TDI, 2.0 TDI 16V, 2.0 TDI 16V 4motion, 2.0 TDI 4motion, 3.2 FSI 4motion, 3.6 R36 4motion		<b>F8-6463</b> H=64; d=12; D=60
Anti-Friction Bearing	All Models		<b>F8-6569</b>
Top Strut Mounting	All Models		<b>F8-6570</b>
Belt Pulley, crankshaft	1.6 TDI	Number of Ribs: 5; Parameter: 6PK	<b>F8-6572</b>
Control Arm-/Trailing Arm Bush	1.4 TSI, 1.4 TSI EcoFuel, 1.6, 1.6 FSI, 1.6 TDI, 1.8 TSI, 1.9 TDI, 2.0 BlueTDI, 2.0 FSI, 2.0 FSI 4motion, 2.0 TDI, 2.0 TDI 16V, 2.0 TDI 16V 4motion, 2.0 TDI 4motion, 3.2 FSI 4motion, 3.6 R36 4motion	ch.→3C-B-050000; Aluminium	<b>F8-6701</b>
Control Arm-/Trailing Arm Bush	1.4 TSI, 1.4 TSI EcoFuel, 1.6, 1.6 FSI, 1.6 TDI, 1.8 TSI, 1.9 TDI, 2.0 BlueTDI, 2.0 FSI, 2.0 FSI 4motion, 2.0 TDI, 2.0 TDI 16V, 2.0 TDI 16V 4motion, 2.0 TDI 4motion, 3.2 FSI 4motion, 3.6 R36 4motion	ch.3C-B-200001→; for OE: F0A, F4F, F4G, F4J, F4Q, F5G, F6B, F6K, F6M; Aluminium; for fire brigade vehicles, for government vehicles, for police vehicles, , for vehicles for the physically handicapped, not for special purpose vehicles	<b>F8-6701</b>
Control Arm-/Trailing Arm Bush	1.4 TSI, 1.4 TSI EcoFuel, 1.6, 1.6 FSI, 1.6 TDI, 1.8 TSI, 1.9 TDI, 2.0 BlueTDI, 2.0 FSI, 2.0 FSI 4motion, 2.0 TDI, 2.0 TDI 16V, 2.0 TDI 16V 4motion, 2.0 TDI 4motion, 3.2 FSI 4motion, 3.6 R36 4motion	ch.→3C-B-050000	<b>F8-6736</b>
Control Arm-/Trailing Arm Bush	1.4 TSI, 1.4 TSI EcoFuel, 1.6, 1.6 FSI, 1.6 TDI, 1.8 TSI, 1.9 TDI, 2.0 BlueTDI, 2.0 FSI, 2.0 FSI 4motion, 2.0 TDI, 2.0 TDI 16V, 2.0 TDI 16V 4motion, 2.0 TDI 4motion, 3.2 FSI 4motion, 3.6 R36 4motion	ch.3C-B-200001→; for OE: F0A, F4F, F4G, F4J, F4Q, F5G, F6B, F6K, F6M; for fire brigade vehicles, for government vehicles, for police vehicles, , for vehicles for the physically handicapped, not for special purpose vehicles	<b>F8-6736</b>
Engine Mounting	1.6		<b>F8-6988</b>
Engine Mounting	1.8 TSI, 1.9 TDI, 2.0 FSI, 2.0 FSI 4motion		<b>F8-6989</b>
Engine Mounting	2.0 FSI	not for  CBFA	<b>F8-6989</b>

<b>F5-1085</b>	<b>F8-5633</b>	<b>F8-5650</b>	<b>F8-6044</b>	<b>F8-6284</b>	<b>F8-6396</b>	<b>F8-6463</b>
Ref.Nr.: 045903119A	Ref.Nr.: 1K0407182A	Ref.Nr.: 06A105243E	Ref.Nr.: 3C0513425	Ref.Nr.: 6N0412249C	Ref.Nr.: 03G105243	Ref.Nr.: 1K0505541B
<b>F8-6569</b>	<b>F8-6570</b>	<b>F8-6572</b>	<b>F8-6701</b>	<b>F8-6736</b>	<b>F8-6988</b>	<b>F8-6989</b>
Ref.Nr.: 6N0412249C	Ref.Nr.: 1K0412331C	Ref.Nr.: 038105243L	Ref.Nr.: 3C0199231A	Ref.Nr.: 1K0407183A	Ref.Nr.: 1K0199262AL	Ref.Nr.: 1K0199262AM
<b>F8-6990</b>						
Ref.Nr.: 1K0199262P						

Article Description



Article Nr.

Fitting Position



PASSAT Variant (3C5)			08/2005 → 10/2011		
Engine Mounting	2.0 TDI, 2.0 TDI 16V		<b>F8-6990</b>		
Engine Mounting	1.6 FSI		<b>F8-6991</b>		
Engine Mounting	3.2 FSI 4motion		<b>F8-7008</b>		
Rubber Buffer, suspension	1.4 TSI, 1.4 TSI EcoFuel, 1.6, 1.6 FSI, 1.8 TSI, 2.0 FSI, 3.6 R36 4motion	for OE: G02, G05, G07, G10, G15, G16, G19; ☆, ▲, <b>ST</b>	<b>F8-7131</b>		H=70
Rubber Buffer, suspension	1.6 TDI, 1.9 TDI, 2.0 BlueTDI, 2.0 TDI, 2.0 TDI 16V	for OE: G07, G10, G15, G19, G37; ☆, ▲, <b>ST</b>	<b>F8-7131</b>		H=70
Rubber Buffer, suspension	2.0 FSI, 2.0 FSI 4motion	for OE: G02, G05, G07, G10, G15, G16, G37; ☆, ▲, <b>ST</b>	<b>F8-7131</b>		H=70
Rubber Buffer, suspension	2.0 TDI	for OE: G07, G10, G15, G16; ☆, ▲, <b>ST</b>	<b>F8-7131</b>		H=70
Rubber Buffer, suspension	2.0 TDI 16V 4motion, 2.0 TDI 4motion	for OE: G07, G10, G15, G16, G19; ☆, ▲, <b>ST</b>	<b>F8-7131</b>		H=70
Rubber Buffer, suspension	3.2 FSI 4motion	for OE: G02, G05, G15, G16; ☆, ▲, <b>ST</b>	<b>F8-7131</b>		H=70
Protective Cap/Bellow, shock absorber	All Models		<b>F8-7132</b>		H=190
Rubber Buffer, suspension	1.4 TSI, 1.4 TSI EcoFuel, 1.6, 1.6 FSI, 1.6 TDI, 1.8 TSI, 1.9 TDI, 2.0 BlueTDI, 2.0 FSI, 2.0 TDI, 2.0 TDI 16V	for OE: 1JA, 1JB, 1JG, 1JL, UA6; ▲, <b>ST</b>	<b>F8-7140</b>		H=133
Rubber Buffer, suspension	2.0 FSI 4motion, 2.0 TDI 16V 4motion, 2.0 TDI 4motion, 3.2 FSI 4motion	for OE: 1JA, 1JB, 1JG, 1JL; ▲, <b>ST</b>	<b>F8-7140</b>		H=133
Rubber Buffer, suspension	1.4 TSI, 1.4 TSI EcoFuel, 1.6, 1.6 FSI, 1.6 TDI, 1.8 TSI, 1.9 TDI, 2.0 BlueTDI, 2.0 FSI, 2.0 FSI 4motion, 2.0 TDI, 2.0 TDI 16V, 2.0 TDI 16V 4motion, 2.0 TDI 4motion, 3.2 FSI 4motion, 3.6 R36 4motion	BlueMotion; for OE: 1K0412303M	<b>F8-7174</b>		H=80
Top Strut Mounting	1.4 TSI, 1.4 TSI EcoFuel, 1.6, 1.6 FSI, 1.6 TDI, 1.8 TSI, 1.9 TDI, 2.0 BlueTDI, 2.0 FSI, 2.0 FSI 4motion, 2.0 TDI, 2.0 TDI 16V, 2.0 TDI 16V 4motion, 2.0 TDI 4motion, 3.2 FSI 4motion	for OE: 1JA; <b>ST</b>	<b>F8-7603</b>		
Top Strut Mounting	1.4 TSI, 1.4 TSI EcoFuel, 1.6, 1.6 FSI, 1.6 TDI, 1.8 TSI, 1.9 TDI, 2.0 BlueTDI, 2.0 FSI, 2.0 FSI 4motion, 2.0 TDI, 2.0 TDI 16V, 2.0 TDI 16V 4motion, 2.0 TDI 4motion, 3.2 FSI 4motion	for OE: 1JB, 1JL; ▲	<b>F8-7603</b>		
Top Strut Mounting	1.4 TSI, 1.4 TSI EcoFuel, 1.6, 1.6 FSI, 1.6 TDI, 1.8 TSI, 1.9 TDI, 2.0 BlueTDI, 2.0 FSI, 2.0 FSI 4motion, 2.0 TDI, 2.0 TDI 16V, 2.0 TDI 16V 4motion, 2.0 TDI 4motion, 3.2 FSI 4motion	for OE: 1JC, 1JK; <b>SP</b>	<b>F8-7603</b>		
Top Strut Mounting	1.4 TSI, 1.4 TSI EcoFuel, 1.6, 1.6 FSI, 1.6 TDI, 1.8 TSI, 1.9 TDI, 2.0 BlueTDI, 2.0 FSI, 2.0 FSI 4motion, 2.0 TDI, 2.0 TDI 16V, 2.0 TDI 16V 4motion, 2.0 TDI 4motion, 3.2 FSI 4motion	for OE: 1JR, UA1; <b>HD</b>	<b>F8-7603</b>		
Top Strut Mounting	1.4 TSI, 1.4 TSI EcoFuel, 1.6, 1.6 FSI, 1.8 TSI, 1.9 TDI, 2.0 BlueTDI, 2.0 FSI, 2.0 FSI 4motion, 2.0 TDI, 2.0 TDI 16V, 2.0 TDI 16V 4motion, 2.0 TDI 4motion, 3.2 FSI 4motion, 3.6 R36 4motion	☆	<b>F8-7603</b>		

<b>F8-6990</b>	<b>F8-6991</b>	<b>F8-7008</b>	<b>F8-7131</b>	<b>F8-7132</b>	<b>F8-7140</b>	<b>F8-7174</b>
Ref.Nr.: 1K0199262P	Ref.Nr.: 1K0199262AK	Ref.Nr.: 1K0199262Q	Ref.Nr.: 1K0412303B	Ref.Nr.: 6N0413175A	Ref.Nr.: 3C0511359	Ref.Nr.: 1K0412303M
<b>F8-7603</b>						
Ref.Nr.: 3C0513353						

**Article Description****Article Nr.****Fitting Position**

<b>PASSAT Variant (3C5)</b>			<b>08/2005 → 10/2011</b>	
Top Strut Mounting	1.4 TSI, 1.6, 1.6 FSI, 1.6 TDI, 1.8 TSI, 1.9 TDI, 2.0 FSI, 2.0 FSI 4motion, 2.0 TDI, 2.0 TDI 16V, 2.0 TDI 16V 4motion, 2.0 TDI 4motion, 3.2 FSI 4motion	for OE: UA5;	<b>F8-7603</b>	
Top Strut Mounting	1.4 TSI, 1.6, 1.6 FSI, 1.6 TDI, 1.8 TSI, 1.9 TDI, 2.0 FSI, 2.0 TDI, 2.0 TDI 16V	BlueMotion; for OE: UA6	<b>F8-7603</b>	
Rubber Buffer, suspension	1.4 TSI, 1.4 TSI EcoFuel, 1.6, 1.6 FSI, 1.6 TDI, 1.8 TSI, 1.9 TDI, 2.0 BlueTDI, 2.0 FSI, 2.0 FSI 4motion, 2.0 TDI, 2.0 TDI 16V, 3.2 FSI 4motion	for OE: G03, G08;	<b>F8-7697</b>	H=55
Rubber Buffer, suspension	1.9 TDI, 2.0 TDI, 2.0 TDI 16V 4motion, 2.0 TDI 4motion	for OE: G08;	<b>F8-7697</b>	H=55
Rubber Buffer, suspension	All Models	for OE: 1JC;	<b>F8-7714</b>	H=118
Rubber Buffer, suspension	All Models		<b>F8-7809</b>	H=55
Rubber Buffer, suspension	All Models	for OE: G04, G09;	<b>F8-7834</b>	H=90
Rubber Buffer, suspension	1.4 TSI, 1.4 TSI EcoFuel, 1.6, 1.6 FSI, 1.6 TDI, 1.8 TSI, 1.9 TDI, 2.0 BlueTDI, 2.0 FSI, 2.0 FSI 4motion, 2.0 TDI, 2.0 TDI 16V, 2.0 TDI 16V 4motion, 2.0 TDI 4motion, 3.2 FSI 4motion	for OE: 1JR, UA1, UA5;	<b>F8-7836</b>	H=143
Engine Mounting	1.6 TDI, 1.8 TSI, 1.9 TDI, 2.0 BlueTDI, 2.0 FSI, 2.0 FSI 4motion, 2.0 TDI, 2.0 TDI 16V, 2.0 TDI 16V 4motion, 2.0 TDI 4motion	Aluminium	<b>F8-7851</b>	
Belt Pulley, crankshaft	1.8 TSI, 2.0 FSI	Number of Ribs: 5; Parameter: 6PK	<b>F8-7880</b>	D=143
Control Arm-/Trailing Arm Bush	All Models		<b>F8-7902</b>	H=60; d=12; D=42
Control Arm-/Trailing Arm Bush	All Models		<b>F8-7907</b>	H=45; d=14; D=38
Control Arm-/Trailing Arm Bush	All Models		<b>F8-7908</b>	H=45; d=12; D=38
Control Arm-/Trailing Arm Bush	All Models		<b>F8-7909</b>	
Stabiliser Mounting	1.6, 1.6 FSI, 2.0 FSI, 2.0 FSI 4motion		<b>F8-7923</b>	d=20,7
Engine Mounting	1.4 TSI		<b>F8-7959</b>	
Engine Mounting	1.6 FSI, 1.9 TDI, 2.0 FSI, 2.0 FSI 4motion, 2.0 TDI	ch.→3C-B-050000	<b>F8-7963</b>	
Engine Mounting	1.6 TDI		<b>F8-7963</b>	
Engine Mounting	1.8 TSI	ch.→3C-B-050000;  BZB	<b>F8-7963</b>	
Engine Mounting	1.8 TSI	ch.→3C-B-050000;  CGYA	<b>F8-7963</b>	
Engine Mounting	1.8 TSI	CDAA	<b>F8-7963</b>	
Engine Mounting	1.8 TSI	CDAB	<b>F8-7963</b>	
Engine Mounting	1.6 FSI, 1.8 TSI, 2.0 FSI, 2.0 FSI 4motion	6-speed	<b>F8-7964</b>	
Engine Mounting	1.8 TSI	Transmission Type: DSG	<b>F8-7964</b>	
Engine Mounting	1.4 TSI EcoFuel, 1.6, 1.6 TDI, 1.8 TSI, 2.0 BlueTDI, 2.0 FSI, 2.0 FSI 4motion, 2.0 TDI, 2.0 TDI 16V, 3.2 FSI 4motion		<b>F8-7982</b>	

<b>F8-7603</b>	<b>F8-7697</b>	<b>F8-7714</b>	<b>F8-7809</b>	<b>F8-7834</b>	<b>F8-7836</b>	<b>F8-7851</b>
Ref.Nr.: 3C0513353	Ref.Nr.: 1K0412303F	Ref.Nr.: 3C0511359B	Ref.Nr.: 1K0412303E	Ref.Nr.: 1K0412303H	Ref.Nr.: 1T0511359	Ref.Nr.: 3C0199855A
<b>F8-7880</b>	<b>F8-7902</b>	<b>F8-7907</b>	<b>F8-7908</b>	<b>F8-7909</b>	<b>F8-7923</b>	<b>F8-7959</b>
Ref.Nr.: 06H105243F	Ref.Nr.: 1K0505171C	Ref.Nr.: 1K0505203A	Ref.Nr.: 1K0505279A	Ref.Nr.: 1K0505553 A	Ref.Nr.: 1K0511327AR	Ref.Nr.: 1K0199262CG
<b>F8-7963</b>	<b>F8-7964</b>	<b>F8-7982</b>				
Ref.Nr.: 3C0199555P	Ref.Nr.: 3C0199555Q	Ref.Nr.: 1K0199868Q				

Article Description



Article Nr.

Fitting Position



<b>PASSAT Variant (3C5)</b>			<b>08/2005 → 10/2011</b>	
Engine Mounting	2.0 FSI	AXZ, BPY, BWA, CAWB, CCTA, CCZA	<b>F8-7982</b>	
Engine Mounting	2.0 FSI	BLR, BLY, BVZ	<b>F8-7982</b>	
Engine Mounting	2.0 TDI	CBBB	<b>F8-7982</b>	
Engine Mounting	2.0 TDI 16V 4motion, 2.0 TDI 4motion	ch.→3C-8-055000	<b>F8-7982</b>	
<b>PASSAT CC (357)</b>			<b>05/2008 → 01/2012</b>	
Alternator Freewheel Clutch	2.0 BlueTDI, 2.0 TDI, 2.0 TDI 4motion		<b>F5-1004</b>	
Alternator Freewheel Clutch	1.8 TSI, 2.0 TSI		<b>F5-1044</b>	
Alternator Freewheel Clutch	1.4 TSI MultiFuel		<b>F5-1064</b>	
Alternator Freewheel Clutch	3.6 FSI 4motion		<b>F5-1085</b>	
Control Arm-/Trailing Arm Bush	All Models		<b>F8-5633</b>	
Protective Cap/Bellow, shock absorber	All Models		<b>F8-6044</b>	H=160
Top Strut Mounting	All Models		<b>F8-6284</b>	
Belt Pulley, crankshaft	2.0 TDI	Number of Ribs: 5; Parameter: 6PK	<b>F8-6396</b>	H=41.6; d=30; Mounting points diam.[mm]=7, 8.6; D=139.7
Anti-Friction Bearing	All Models		<b>F8-6569</b>	
Top Strut Mounting	All Models		<b>F8-6570</b>	
Belt Pulley, crankshaft	2.0 TDI	CFFA; Number of Ribs: 5; Parameter: 6PK	<b>F8-6572</b>	
Belt Pulley, crankshaft	2.0 TDI	CFGB, CLLA; Number of Ribs: 5; Parameter: 6PK	<b>F8-6572</b>	
Belt Pulley, crankshaft	2.0 TDI 4motion	CFGB; Number of Ribs: 5; Parameter: 6PK	<b>F8-6572</b>	
Belt Pulley, crankshaft	2.0 TDI, 2.0 TDI 4motion	CFFB; Number of Ribs: 5; Parameter: 6PK	<b>F8-6572</b>	
Control Arm-/Trailing Arm Bush	All Models	Aluminium	<b>F8-6701</b>	
Control Arm-/Trailing Arm Bush	All Models		<b>F8-6736</b>	
Engine Mounting	1.8 TSI, 2.0 TSI		<b>F8-6989</b>	
Protective Cap/Bellow, shock absorber	All Models		<b>F8-7132</b>	H=190
Top Strut Mounting	1.4 TSI MultiFuel, 1.8 TSI, 2.0 BlueTDI, 2.0 TDI, 2.0 TDI 4motion, 2.0 TSI, 3.6 FSI 4motion	<b>ST</b>	<b>F8-7603</b>	
Top Strut Mounting	1.8 TSI, 2.0 TDI, 2.0 TSI, 3.6 FSI 4motion	ch.→3C-9-575000;	<b>F8-7603</b>	
Top Strut Mounting	2.0 TDI		<b>F8-7603</b>	
Rubber Buffer, suspension	All Models	<b>SP</b>	<b>F8-7697</b>	H=55
Rubber Buffer, suspension	All Models	for OE: UA4, UC1; <b>ST</b>	<b>F8-7714</b>	H=118



**Article Description****Article Nr.****Fitting Position**

<b>PASSAT CC (357)</b>				<b>05/2008 → 01/2012</b>	
Rubber Buffer, suspension	All Models		<b>F8-7809</b>		H=55
Engine Mounting	1.8 TSI, 2.0 BlueTDI, 2.0 TDI, 2.0 TDI 4motion, 2.0 TSI	Aluminium	<b>F8-7851</b>		
Belt Pulley, crankshaft	1.8 TSI, 2.0 TSI	Number of Ribs: 5; Parameter: 6PK	<b>F8-7880</b>		D=143
Control Arm-/Trailing Arm Bush	1.8 TSI, 2.0 BlueTDI, 2.0 TDI, 2.0 TDI 4motion, 2.0 TSI, 3.6 FSI 4motion		<b>F8-7909</b>		
Engine Mounting	1.8 TSI	ch.->3C-B-050000	<b>F8-7963</b>		
Engine Mounting	1.8 TSI	Transmission Type: DSG	<b>F8-7964</b>		
Engine Mounting	1.8 TSI, 2.0 TSI	6-speed	<b>F8-7964</b>		
Engine Mounting	1.4 TSI MultiFuel, 1.8 TSI, 2.0 BlueTDI, 2.0 TDI, 2.0 TSI		<b>F8-7982</b>		
Engine Mounting	2.0 TDI 4motion	CFGB	<b>F8-7982</b>		
Engine Mounting	2.0 TSI	CAWB, CBFA, CCTA, CCZA	<b>F8-7982</b>		
<b>PASSAT (362)</b>				<b>08/2010 → 12/2014</b>	
Alternator Freewheel Clutch	1.6 TDI, 2.0 TDI, 2.0 TDI 4motion		<b>F5-1004</b>		
Alternator Freewheel Clutch	1.8 TSI, 2.0 TSI		<b>F5-1044</b>		
Alternator Freewheel Clutch	1.4 TSI, 1.4 TSI EcoFuel, 1.4 TSI MultiFuel		<b>F5-1064</b>		
Alternator Freewheel Clutch	3.6 FSI 4motion		<b>F5-1085</b>		
Control Arm-/Trailing Arm Bush	1.4 TSI, 1.4 TSI EcoFuel, 1.4 TSI MultiFuel, 1.6 TDI, 1.8 TSI, 2.0 TDI, 2.0 TDI 4motion, 2.0 TSI, 3.6 FSI 4motion		<b>F8-5633</b>		
Protective Cap/Bellow, shock absorber	1.4 TSI, 1.4 TSI EcoFuel, 1.4 TSI MultiFuel, 1.6 TDI, 1.8 TSI, 2.0 TDI, 2.0 TDI 4motion, 2.0 TSI, 3.6 FSI 4motion		<b>F8-6044</b>		
Protective Cap/Bellow, shock absorber	1.4 TSI, 1.4 TSI EcoFuel, 1.4 TSI MultiFuel, 1.6 TDI, 1.8 TSI, 2.0 TDI, 2.0 TSI	for OE: 1JA, 1JB, 1JC, 1JG, 1JK, 1JL, UAO, UA1, UA5, UC7; , , , ,	<b>F8-6044</b>		
Protective Cap/Bellow, shock absorber	2.0 TDI 4motion, 3.6 FSI 4motion	for OE: 1JA, 1JB, 1JC, 1JK, 1JL, UC7; , , , ,	<b>F8-6044</b>		
Top Strut Mounting	1.4 TSI, 1.4 TSI EcoFuel, 1.4 TSI MultiFuel, 1.6 TDI, 1.8 TSI, 2.0 TDI, 2.0 TDI 4motion, 2.0 TSI, 3.6 FSI 4motion		<b>F8-6284</b>		
Anti-Friction Bearing	1.4 TSI, 1.4 TSI EcoFuel, 1.4 TSI MultiFuel, 1.6 TDI, 1.8 TSI, 2.0 TDI, 2.0 TDI 4motion, 2.0 TSI, 3.6 FSI 4motion		<b>F8-6569</b>		
Top Strut Mounting	1.4 TSI, 1.4 TSI EcoFuel, 1.4 TSI MultiFuel, 1.6 TDI, 1.8 TSI, 2.0 TDI, 2.0 TDI 4motion, 2.0 TSI, 3.6 FSI 4motion		<b>F8-6570</b>		
Belt Pulley, crankshaft	1.6 TDI, 2.0 TDI, 2.0 TDI 4motion	Number of Ribs: 5; Parameter: 6PK	<b>F8-6572</b>		
Belt Pulley, crankshaft	2.0 TDI 4motion	CFGB; Number of Ribs: 5; Parameter: 6PK	<b>F8-6572</b>		
Engine Mounting	1.8 TSI, 2.0 TSI		<b>F8-6989</b>		

<b>F5-1004</b>	<b>F5-1044</b>	<b>F5-1064</b>	<b>F5-1085</b>	<b>F8-5633</b>	<b>F8-6044</b>	<b>F8-6284</b>
Ref.Nr.: 038903119T	Ref.Nr.: 06B903119B	Ref.Nr.: 03C903119D	Ref.Nr.: 045903119A	Ref.Nr.: 1K0407182A	Ref.Nr.: 3C0513425	Ref.Nr.: 6N0412249C
<b>F8-6569</b>	<b>F8-6570</b>	<b>F8-6572</b>	<b>F8-6989</b>	<b>F8-7131</b>	<b>F8-7809</b>	<b>F8-7851</b>
Ref.Nr.: 6N0412249C	Ref.Nr.: 1K0412331C	Ref.Nr.: 038105243L	Ref.Nr.: 1K0199262AM	Ref.Nr.: 1K0412303B	Ref.Nr.: 1K0412303E	Ref.Nr.: 3C0199855A
<b>F8-7880</b>	<b>F8-7909</b>	<b>F8-7963</b>	<b>F8-7964</b>	<b>F8-7982</b>		
Ref.Nr.: 06H105243F	Ref.Nr.: 1K0505553 A	Ref.Nr.: 3C0199555P	Ref.Nr.: 3C0199555Q	Ref.Nr.: 1K0199868Q		

Article Description



Article Nr.

Fitting Position



PASSAT (362)			08/2010 → 12/2014		
Rubber Buffer, suspension	1.4 TSI, 1.4 TSI EcoFuel, 1.4 TSI MultiFuel, 1.8 TSI, 2.0 TSI	for OE: G02, G07, G10, G19; ☆, △, <b>ST</b>	<b>F8-7131</b>	⊕ ⊕	H=70
Rubber Buffer, suspension	1.6 TDI, 2.0 TDI	for OE: G05, G07, G10, G15, G16, G19, G37; ☆, △, <b>ST</b>	<b>F8-7131</b>	⊕ ⊕	H=70
Rubber Buffer, suspension	2.0 TDI 4motion	for OE: G07, G10, G15, G16, G19; ☆, △, <b>ST</b>	<b>F8-7131</b>	⊕ ⊕	H=70
Rubber Buffer, suspension	2.0 TDI 4motion	CFGB; for OE: G07, G10, G15, G16, G19; ☆, △, <b>ST</b>	<b>F8-7131</b>	⊕ ⊕	H=70
Rubber Buffer, suspension	3.6 FSI 4motion	for OE: G15, G16; ☆, △, <b>ST</b>	<b>F8-7131</b>	⊕ ⊕	H=70
Protective Cap/Bellow, shock absorber	1.4 TSI, 1.4 TSI EcoFuel, 1.4 TSI MultiFuel, 1.6 TDI, 1.8 TSI, 2.0 TDI, 2.0 TDI 4motion, 2.0 TSI, 3.6 FSI 4motion		<b>F8-7132</b>	⊕ ⊕	H=190
Rubber Buffer, suspension	1.4 TSI, 1.4 TSI EcoFuel, 1.4 TSI MultiFuel, 1.6 TDI, 1.8 TSI, 2.0 TDI, 2.0 TSI	for OE: 1JA, 1JB, 1JG, 1JL, UA0, UC5, UC7; ☆, □, △, <b>ST</b>	<b>F8-7140</b>	⊕ ⊕	H=133
Rubber Buffer, suspension	2.0 TDI 4motion, 3.6 FSI 4motion	for OE: 1JA, 1JB, 1JL, UC7; ☆, □, △, <b>ST</b>	<b>F8-7140</b>	⊕ ⊕	H=133
Top Strut Mounting	1.4 TSI, 1.4 TSI EcoFuel, 1.4 TSI MultiFuel, 1.6 TDI, 1.8 TSI, 2.0 TDI, 2.0 TDI 4motion, 2.0 TSI, 3.6 FSI 4motion	for OE: 1JA; <b>ST</b>	<b>F8-7603</b>	⊕ ⊕	
Top Strut Mounting	1.4 TSI, 1.4 TSI EcoFuel, 1.4 TSI MultiFuel, 1.6 TDI, 1.8 TSI, 2.0 TDI, 2.0 TDI 4motion, 2.0 TSI, 3.6 FSI 4motion	for OE: 1JB, 1JL; △	<b>F8-7603</b>	⊕ ⊕	
Top Strut Mounting	1.4 TSI, 1.4 TSI EcoFuel, 1.4 TSI MultiFuel, 1.6 TDI, 1.8 TSI, 2.0 TDI, 2.0 TDI 4motion, 2.0 TSI, 3.6 FSI 4motion	for OE: 1JC, 1JK; <b>SP</b>	<b>F8-7603</b>	⊕ ⊕	
Top Strut Mounting	1.4 TSI, 1.4 TSI EcoFuel, 1.4 TSI MultiFuel, 1.6 TDI, 1.8 TSI, 2.0 TDI, 2.0 TDI 4motion, 2.0 TSI, 3.6 FSI 4motion	for OE: 1JR, UA1; <b>HD</b>	<b>F8-7603</b>	⊕ ⊕	
Top Strut Mounting	1.4 TSI, 1.4 TSI EcoFuel, 1.4 TSI MultiFuel, 1.6 TDI, 1.8 TSI, 2.0 TDI, 2.0 TSI	for OE: UC7; □	<b>F8-7603</b>	⊕ ⊕	
Top Strut Mounting	1.4 TSI, 1.6 TDI, 1.8 TSI, 2.0 TDI, 2.0 TSI	BlueMotion; for OE: UA0, UA6	<b>F8-7603</b>	⊕ ⊕	
Top Strut Mounting	1.4 TSI, 1.6 TDI, 1.8 TSI, 2.0 TDI, 2.0 TSI	for OE: UA5;	<b>F8-7603</b>	⊕ ⊕	
Rubber Buffer, suspension	1.4 TSI, 1.4 TSI EcoFuel, 1.4 TSI MultiFuel, 1.8 TSI, 2.0 TSI	for OE: G03; <b>SP</b>	<b>F8-7697</b>		H=55
Rubber Buffer, suspension	1.6 TDI, 2.0 TDI	for OE: G03, G08; <b>SP</b>	<b>F8-7697</b>		H=55
Rubber Buffer, suspension	2.0 TDI 4motion	for OE: G08; <b>SP</b>	<b>F8-7697</b>		H=55
Rubber Buffer, suspension	1.4 TSI, 1.4 TSI EcoFuel, 1.4 TSI MultiFuel, 1.6 TDI, 1.8 TSI, 2.0 TDI, 2.0 TDI 4motion, 2.0 TSI, 3.6 FSI 4motion	for OE: 1JC; <b>SP</b>	<b>F8-7714</b>		H=118
Rubber Buffer, suspension	1.4 TSI, 1.4 TSI EcoFuel, 1.4 TSI MultiFuel, 1.6 TDI, 1.8 TSI, 2.0 TDI, 2.0 TDI 4motion, 2.0 TSI	for OE: G41;	<b>F8-7809</b>		H=55
Rubber Buffer, suspension	All Models	for OE: G04, G09; △	<b>F8-7834</b>	⊕ ⊕	H=90
Rubber Buffer, suspension	1.4 TSI, 1.4 TSI EcoFuel, 1.4 TSI MultiFuel, 1.6 TDI, 1.8 TSI, 2.0 TDI, 2.0 TSI	for OE: UA1, UA5, UC8; <b>HD</b>	<b>F8-7836</b>	⊕ ⊕	H=143

<b>F8-7131</b>	<b>F8-7132</b>	<b>F8-7140</b>	<b>F8-7603</b>	<b>F8-7697</b>	<b>F8-7714</b>	<b>F8-7809</b>
Ref.Nr.: 1K0412303B	Ref.Nr.: 6N0413175A	Ref.Nr.: 3C0511359	Ref.Nr.: 3C0513353	Ref.Nr.: 1K0412303F	Ref.Nr.: 3C0511359B	Ref.Nr.: 1K0412303E
<b>F8-7834</b>	<b>F8-7836</b>	<b>F8-7851</b>				
Ref.Nr.: 1K0412303H	Ref.Nr.: 1T0511359	Ref.Nr.: 3C0199855A				



**Article Description****Article Nr.****Fitting Position****PASSAT (362) 08/2010 → 12/2014**

Engine Mounting	1.6 TDI, 1.8 TSI, 2.0 TDI, 2.0 TDI 4motion, 2.0 TSI	Aluminium	<b>F8-7851</b>	
Belt Pulley, crankshaft	1.8 TSI, 2.0 TSI	Number of Ribs: 5; Parameter: 6PK	<b>F8-7880</b>	D=143
Control Arm-/Trailing Arm Bush	1.4 TSI, 1.4 TSI EcoFuel, 1.4 TSI MultiFuel, 1.6 TDI, 1.8 TSI, 2.0 TDI, 2.0 TSI		<b>F8-7902</b>	H=60; d=12; D=42
Control Arm-/Trailing Arm Bush	1.4 TSI, 1.4 TSI EcoFuel, 1.4 TSI MultiFuel, 1.6 TDI, 1.8 TSI, 2.0 TDI, 2.0 TSI		<b>F8-7907</b>	H=45; d=14; D=38
Control Arm-/Trailing Arm Bush	1.4 TSI, 1.4 TSI EcoFuel, 1.4 TSI MultiFuel, 1.6 TDI, 1.8 TSI, 2.0 TDI, 2.0 TSI		<b>F8-7908</b>	H=45; d=12; D=38
Control Arm-/Trailing Arm Bush	1.4 TSI, 1.4 TSI EcoFuel, 1.4 TSI MultiFuel, 1.6 TDI, 1.8 TSI, 2.0 TDI, 2.0 TSI		<b>F8-7909</b>	
Stabiliser Mounting	1.4 TSI, 1.4 TSI EcoFuel, 1.4 TSI MultiFuel, 1.6 TDI, 1.8 TSI, 2.0 TDI, 2.0 TDI 4motion, 2.0 TSI, 3.6 FSI 4motion	<b>ST</b>	<b>F8-7923</b>	d=20,7
Engine Mounting	1.4 TSI, 1.4 TSI EcoFuel, 1.4 TSI MultiFuel, 1.6 TDI, 1.8 TSI, 2.0 TDI, 2.0 TDI 4motion, 2.0 TSI		<b>F8-7982</b>	

**PASSAT Variant (365) 08/2010 → 12/2014**

Alternator Freewheel Clutch	1.6 TDI, 2.0 TDI, 2.0 TDI 4motion		<b>F5-1004</b>	
Alternator Freewheel Clutch	1.8 TSI, 2.0 TSI		<b>F5-1044</b>	
Alternator Freewheel Clutch	1.4 TSI, 1.4 TSI EcoFuel, 1.4 TSI MultiFuel		<b>F5-1064</b>	
Alternator Freewheel Clutch	3.6 FSI 4motion		<b>F5-1085</b>	
Control Arm-/Trailing Arm Bush	1.4 TSI, 1.4 TSI EcoFuel, 1.4 TSI MultiFuel, 1.6 TDI, 1.8 TSI, 2.0 TDI, 2.0 TDI 4motion, 2.0 TSI, 3.6 FSI 4motion		<b>F8-5633</b>	
Protective Cap/Bellow, shock absorber	1.4 TSI, 1.4 TSI EcoFuel, 1.4 TSI MultiFuel, 1.6 TDI, 1.8 TSI, 2.0 TDI, 2.0 TDI 4motion, 2.0 TSI, 3.6 FSI 4motion		<b>F8-6044</b>	H=160
Protective Cap/Bellow, shock absorber	1.4 TSI, 1.4 TSI EcoFuel, 1.4 TSI MultiFuel, 1.6 TDI, 1.8 TSI, 2.0 TDI, 2.0 TSI	for OE: 1JA, 1JB, 1JC, 1JG, 1JK, 1JL, 1JR, UA0, UA1, UA5, UA6, UC7; <b>HD</b> , <b>OI</b> , <b>Δ</b> , <b>SP</b> , <b>ST</b>	<b>F8-6044</b>	H=160
Protective Cap/Bellow, shock absorber	2.0 TDI 4motion, 3.6 FSI 4motion	for OE: 1JA, 1JB, 1JC, 1JK, 1JL, 1JR, UA6, UC7; <b>HD</b> , <b>OI</b> , <b>Δ</b> , <b>SP</b> , <b>ST</b>	<b>F8-6044</b>	H=160
Top Strut Mounting	1.4 TSI, 1.4 TSI EcoFuel, 1.4 TSI MultiFuel, 1.6 TDI, 1.8 TSI, 2.0 TDI, 2.0 TDI 4motion, 2.0 TSI, 3.6 FSI 4motion		<b>F8-6284</b>	
Anti-Friction Bearing	1.4 TSI, 1.4 TSI EcoFuel, 1.4 TSI MultiFuel, 1.6 TDI, 1.8 TSI, 2.0 TDI, 2.0 TDI 4motion, 2.0 TSI, 3.6 FSI 4motion		<b>F8-6569</b>	
Top Strut Mounting	1.4 TSI, 1.4 TSI EcoFuel, 1.4 TSI MultiFuel, 1.6 TDI, 1.8 TSI, 2.0 TDI, 2.0 TDI 4motion, 2.0 TSI, 3.6 FSI 4motion		<b>F8-6570</b>	
Belt Pulley, crankshaft	1.6 TDI, 2.0 TDI, 2.0 TDI 4motion	Number of Ribs: 5; Parameter: 6PK	<b>F8-6572</b>	
Belt Pulley, crankshaft	2.0 TDI 4motion	CFGB; Number of Ribs: 5; Parameter: 6PK	<b>F8-6572</b>	

<b>F5-1004</b>	<b>F5-1044</b>	<b>F5-1064</b>	<b>F5-1085</b>	<b>F8-5633</b>	<b>F8-6044</b>	<b>F8-6284</b>
Ref.Nr.: 038903119T	Ref.Nr.: 06B903119B	Ref.Nr.: 03C903119D	Ref.Nr.: 045903119A	Ref.Nr.: 1K0407182A	Ref.Nr.: 3C0513425	Ref.Nr.: 6N0412249C
<b>F8-6569</b>	<b>F8-6570</b>	<b>F8-6572</b>	<b>F8-6989</b>	<b>F8-7851</b>	<b>F8-7880</b>	<b>F8-7902</b>
Ref.Nr.: 6N0412249C	Ref.Nr.: 1K0412331C	Ref.Nr.: 038105243L	Ref.Nr.: 1K0199262AM	Ref.Nr.: 3C0199855A	Ref.Nr.: 06H105243F	Ref.Nr.: 1K0505171C
<b>F8-7907</b>	<b>F8-7908</b>	<b>F8-7909</b>	<b>F8-7923</b>	<b>F8-7982</b>		
Ref.Nr.: 1K0505203A	Ref.Nr.: 1K0505279A	Ref.Nr.: 1K0505553 A	Ref.Nr.: 1K0511327AR	Ref.Nr.: 1K0199868Q		

Article Description



Article Nr.

Fitting Position



**PASSAT Variant (365)**

08/2010 → 12/2014

Article Description	Engine Mounting	for OE:	Article Nr.	Fitting Position	H=
Engine Mounting	1.8 TSI, 2.0 TSI		<b>F8-6989</b>		
Rubber Buffer, suspension	1.4 TSI, 1.4 TSI EcoFuel, 1.4 TSI MultiFuel, 1.8 TSI, 2.0 TSI	for OE: G02, G07, G10, G19; ☆, △, <b>ST</b>	<b>F8-7131</b>		H=70
Rubber Buffer, suspension	1.6 TDI, 2.0 TDI	for OE: G05, G07, G10, G15, G16, G19, G37; ☆, △, <b>ST</b>	<b>F8-7131</b>		H=70
Rubber Buffer, suspension	2.0 TDI 4motion	for OE: G07, G10, G15, G16, G19; ☆, △, <b>ST</b>	<b>F8-7131</b>		H=70
Rubber Buffer, suspension	2.0 TDI 4motion	CFGB; for OE: G07, G10, G15, G16, G19; ☆, △, <b>ST</b>	<b>F8-7131</b>		H=70
Rubber Buffer, suspension	3.6 FSI 4motion	for OE: G02, G07, G10, G15, G16, G19; ☆, △, <b>ST</b>	<b>F8-7131</b>		H=70
Protective Cap/Bellow, shock absorber	1.4 TSI, 1.4 TSI EcoFuel, 1.4 TSI MultiFuel, 1.6 TDI, 1.8 TSI, 2.0 TDI, 2.0 TDI 4motion, 2.0 TSI, 3.6 FSI 4motion		<b>F8-7132</b>		H=190
Rubber Buffer, suspension	1.4 TSI, 1.4 TSI EcoFuel, 1.4 TSI MultiFuel, 1.6 TDI, 1.8 TSI, 2.0 TDI, 2.0 TSI	for OE: 1JA, 1JB, 1JG, 1JL, 1JR, UA0, UA5, UA6, UC5, UC7; ☆, <b>HD</b> , <b>OI</b> , △, <b>ST</b>	<b>F8-7140</b>		H=133
Rubber Buffer, suspension	2.0 TDI 4motion, 3.6 FSI 4motion	for OE: 1JA, 1JB, 1JL, UC7; ☆, <b>OI</b> , △, <b>ST</b>	<b>F8-7140</b>		H=133
Top Strut Mounting	1.4 TSI, 1.4 TSI EcoFuel, 1.4 TSI MultiFuel, 1.6 TDI, 1.8 TSI, 2.0 TDI, 2.0 TDI 4motion, 2.0 TSI, 3.6 FSI 4motion	for OE: 1JA; <b>ST</b>	<b>F8-7603</b>		
Top Strut Mounting	1.4 TSI, 1.4 TSI EcoFuel, 1.4 TSI MultiFuel, 1.6 TDI, 1.8 TSI, 2.0 TDI, 2.0 TDI 4motion, 2.0 TSI, 3.6 FSI 4motion	for OE: 1JB, 1JL; △	<b>F8-7603</b>		
Top Strut Mounting	1.4 TSI, 1.4 TSI EcoFuel, 1.4 TSI MultiFuel, 1.6 TDI, 1.8 TSI, 2.0 TDI, 2.0 TDI 4motion, 2.0 TSI, 3.6 FSI 4motion	for OE: 1JC, 1JK; <b>SP</b>	<b>F8-7603</b>		
Top Strut Mounting	1.4 TSI, 1.4 TSI EcoFuel, 1.4 TSI MultiFuel, 1.6 TDI, 1.8 TSI, 2.0 TDI, 2.0 TDI 4motion, 2.0 TSI, 3.6 FSI 4motion	for OE: 1JR, UA1; <b>HD</b>	<b>F8-7603</b>		
Top Strut Mounting	1.4 TSI, 1.4 TSI EcoFuel, 1.4 TSI MultiFuel, 1.6 TDI, 1.8 TSI, 2.0 TDI, 2.0 TSI	for OE: UC7; <b>OI</b>	<b>F8-7603</b>		
Top Strut Mounting	1.4 TSI, 1.6 TDI, 1.8 TSI, 2.0 TDI, 2.0 TSI	BlueMotion; for OE: UA0, UA6	<b>F8-7603</b>		
Top Strut Mounting	1.4 TSI, 1.6 TDI, 1.8 TSI, 2.0 TDI, 2.0 TSI	for OE: UA5; <b>I</b>	<b>F8-7603</b>		
Rubber Buffer, suspension	1.4 TSI, 1.4 TSI EcoFuel, 1.4 TSI MultiFuel, 1.8 TSI, 2.0 TSI	for OE: G03; <b>SP</b>	<b>F8-7697</b>		H=55
Rubber Buffer, suspension	1.6 TDI, 2.0 TDI	for OE: G03, G08; <b>SP</b>	<b>F8-7697</b>		H=55
Rubber Buffer, suspension	2.0 TDI 4motion, 3.6 FSI 4motion	for OE: G08; <b>SP</b>	<b>F8-7697</b>		H=55
Rubber Buffer, suspension	1.4 TSI, 1.4 TSI EcoFuel, 1.4 TSI MultiFuel, 1.6 TDI, 1.8 TSI, 2.0 TDI, 2.0 TDI 4motion, 2.0 TSI, 3.6 FSI 4motion	for OE: 1JC; <b>SP</b>	<b>F8-7714</b>		H=118
Rubber Buffer, suspension	1.4 TSI, 1.4 TSI EcoFuel, 1.4 TSI MultiFuel, 1.6 TDI, 1.8 TSI, 2.0 TDI, 2.0 TDI 4motion, 2.0 TSI, 3.6 FSI 4motion	for OE: G41; <b>I</b>	<b>F8-7809</b>		H=55

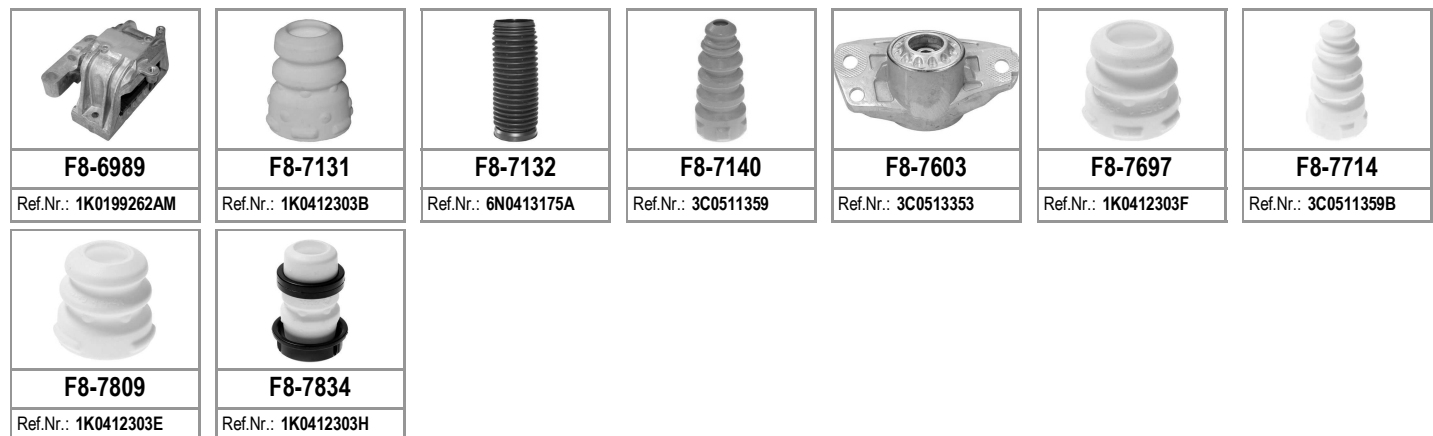

**Article Description****Article Nr.****Fitting Position****PASSAT Variant (365) 08/2010 → 12/2014**

Rubber Buffer, suspension	All Models	for OE: G04, G09;	<b>F8-7834</b>		H=90
Rubber Buffer, suspension	1.4 TSI, 1.4 TSI EcoFuel, 1.4 TSI MultiFuel, 1.6 TDI, 1.8 TSI, 2.0 TDI, 2.0 TSI	for OE: UA1, UC8;	<b>F8-7836</b>		H=143
Rubber Buffer, suspension	2.0 TDI 4motion	for OE: 1JR;	<b>F8-7836</b>		H=143
Engine Mounting	1.6 TDI, 1.8 TSI, 2.0 TDI, 2.0 TDI 4motion, 2.0 TSI	Aluminium	<b>F8-7851</b>		
Belt Pulley, crankshaft	1.8 TSI, 2.0 TSI	Number of Ribs: 5; Parameter: 6PK	<b>F8-7880</b>		D=143
Control Arm-/Trailing Arm Bush	1.4 TSI, 1.4 TSI EcoFuel, 1.4 TSI MultiFuel, 1.6 TDI, 1.8 TSI, 2.0 TDI, 2.0 TSI		<b>F8-7902</b>		H=60; d=12; D=42
Control Arm-/Trailing Arm Bush	1.4 TSI, 1.4 TSI EcoFuel, 1.4 TSI MultiFuel, 1.6 TDI, 1.8 TSI, 2.0 TDI, 2.0 TSI		<b>F8-7907</b>		H=45; d=14; D=38
Control Arm-/Trailing Arm Bush	1.4 TSI, 1.4 TSI EcoFuel, 1.4 TSI MultiFuel, 1.6 TDI, 1.8 TSI, 2.0 TDI, 2.0 TSI		<b>F8-7908</b>		H=45; d=12; D=38
Control Arm-/Trailing Arm Bush	1.4 TSI, 1.4 TSI EcoFuel, 1.4 TSI MultiFuel, 1.6 TDI, 1.8 TSI, 2.0 TDI, 2.0 TSI		<b>F8-7909</b>		
Stabiliser Mounting	1.4 TSI, 1.4 TSI EcoFuel, 1.4 TSI MultiFuel, 1.6 TDI, 1.8 TSI, 2.0 TDI, 2.0 TDI 4motion, 2.0 TSI, 3.6 FSI 4motion		<b>F8-7923</b>		d=20,7
Engine Mounting	1.4 TSI, 1.4 TSI EcoFuel, 1.4 TSI MultiFuel, 1.6 TDI, 1.8 TSI, 2.0 TDI, 2.0 TDI 4motion, 2.0 TSI		<b>F8-7982</b>		

**PASSAT ALLTRACK (365) 01/2012 → 12/2014**

Alternator Freewheel Clutch	2.0 TDI, 2.0 TDI 4motion		<b>F5-1004</b>		
Alternator Freewheel Clutch	1.8 TSI, 2.0 TSI 4motion		<b>F5-1044</b>		
Control Arm-/Trailing Arm Bush	2.0 TSI 4motion		<b>F8-5633</b>		
Protective Cap/Bellow, shock absorber	1.8 TSI, 2.0 TDI, 2.0 TDI 4motion, 2.0 TSI 4motion	for OE: UB3, UB4	<b>F8-6044</b>		H=160
Protective Cap/Bellow, shock absorber	1.8 TSI, 2.0 TDI, 2.0 TDI 4motion, 2.0 TSI 4motion		<b>F8-6044</b>		H=160
Top Strut Mounting	All Models		<b>F8-6284</b>		
Anti-Friction Bearing	All Models		<b>F8-6569</b>		
Top Strut Mounting	All Models		<b>F8-6570</b>		
Engine Mounting	2.0 TSI 4motion		<b>F8-6989</b>		
Rubber Buffer, suspension	1.8 TSI	for OE: G02, G07, G10, G19; , ,	<b>F8-7131</b>		H=70
Rubber Buffer, suspension	2.0 TDI 4motion	for OE: G07, G10, G15, G16, G19; , ,	<b>F8-7131</b>		H=70
Protective Cap/Bellow, shock absorber	All Models		<b>F8-7132</b>		H=190
Rubber Buffer, suspension	All Models	for OE: UB3, UB4	<b>F8-7140</b>		H=133
Top Strut Mounting	1.8 TSI, 2.0 TDI, 2.0 TDI 4motion, 2.0 TSI 4motion		<b>F8-7603</b>		
Rubber Buffer, suspension	2.0 TSI 4motion	for OE: 1JC;	<b>F8-7714</b>		H=118

<b>F5-1004</b>	<b>F5-1044</b>	<b>F8-5633</b>	<b>F8-6044</b>	<b>F8-6284</b>	<b>F8-6569</b>	<b>F8-6570</b>
Ref.Nr.: 038903119T	Ref.Nr.: 06B903119B	Ref.Nr.: 1K0407182A	Ref.Nr.: 3C0513425	Ref.Nr.: 6N0412249C	Ref.Nr.: 6N0412249C	Ref.Nr.: 1K0412331C
<b>F8-6989</b>	<b>F8-7131</b>	<b>F8-7132</b>	<b>F8-7140</b>	<b>F8-7603</b>	<b>F8-7714</b>	<b>F8-7834</b>
Ref.Nr.: 1K0199262AM	Ref.Nr.: 1K0412303B	Ref.Nr.: 6N0413175A	Ref.Nr.: 3C0511359	Ref.Nr.: 3C0513353	Ref.Nr.: 3C0511359B	Ref.Nr.: 1K0412303H
<b>F8-7836</b>	<b>F8-7851</b>	<b>F8-7880</b>	<b>F8-7902</b>	<b>F8-7907</b>	<b>F8-7908</b>	<b>F8-7909</b>
Ref.Nr.: 1T0511359	Ref.Nr.: 3C0199855A	Ref.Nr.: 06H105243F	Ref.Nr.: 1K0505171C	Ref.Nr.: 1K0505203A	Ref.Nr.: 1K0505279A	Ref.Nr.: 1K0505553 A

Article Description



Article Nr.

Fitting Position



<b>PASSAT ALLTRACK (365)</b>			<b>01/2012 → 12/2014</b>	
Rubber Buffer, suspension	All Models	for OE: G43	<b>F8-7834</b>	
Belt Pulley, crankshaft	1.8 TSI, 2.0 TSI 4motion	Number of Ribs: 5; Parameter: 6PK	<b>F8-7880</b>	H=90 D=143
Engine Mounting	All Models		<b>F8-7982</b>	
<b>PHAETON (3D_)</b>			<b>04/2002 →</b>	
Alternator Freewheel Clutch	5.0 V10 TDI 4motion		<b>F5-1103</b>	
Alternator Freewheel Clutch	3.0 V6 TDI 4motion		<b>F5-1140</b>	
Control Arm-/Trailing Arm Bush	3.0 V6 TDI 4motion, 3.2 V6, 3.2 V6 4motion, 3.6 V6 4motion, 4.2 V8 4motion, 5.0 V10 TDI 4motion, 6.0 W12 4motion		<b>F8-7795</b>	
Control Arm-/Trailing Arm Bush	3.0 V6 TDI 4motion	CEXA	<b>F8-7796</b>	H=40; d=10; D=46,5
Control Arm-/Trailing Arm Bush	3.0 V6 TDI 4motion, 3.2 V6, 3.2 V6 4motion, 3.6 V6 4motion, 4.2 V8 4motion, 5.0 V10 TDI 4motion, 6.0 W12 4motion		<b>F8-7796</b>	H=40; d=10; D=46,5
Control Arm-/Trailing Arm Bush	3.0 V6 TDI 4motion, 3.2 V6, 3.2 V6 4motion, 3.6 V6 4motion, 4.2 V8 4motion, 5.0 V10 TDI 4motion, 6.0 W12 4motion		<b>F8-8117</b>	H=80; d=12,2; D=75
Bellow Set, drive shaft	3.2 V6	AYT; with clamps	<b>MK-810160</b>	L=116
Bellow Set, drive shaft	5.0 V10 TDI 4motion	with clamps	<b>MK-810160</b>	L=116
Bellow Set, drive shaft	6.0 W12 4motion	with clamps;	<b>MK-810160</b>	L=116
<b>POLO (86)</b>			<b>03/1975 → 09/1981</b>	
Dust Cover Kit, shock absorber	0.8, 0.9, 1.1, 1.3		<b>AK-735014</b>	
Dust Cover Kit, shock absorber	1.1	08/1975 →	<b>AK-735014</b>	
Dust Cover Kit, shock absorber	All Models		<b>AK-735025</b>	
Dust Cover Kit, shock absorber	0.9, 1.3		<b>AK-735027</b>	
Dust Cover Kit, shock absorber	1.1	04/1975 →	<b>AK-735027</b>	
Flange, carburettor	0.9, 1.1		<b>F8-4013</b>	H1=84; H2=95; d=36; T [mm]=68
Rubber Buffer, silencer	1.3		<b>F8-4026</b>	H=12; W=57, 60
Control Arm-/Trailing Arm Bush	0.9, 1.1, 1.3	ch.869-2523523 →	<b>F8-4042</b>	H=44; d=10; D1=38; D2=42
Bellow, driveshaft	0.9, 1.1, 1.3		<b>F8-4080</b>	H=95; D1=29; D2=96
Bellow, steering	0.9, 1.1, 1.3	01/1980 →	<b>F8-5044</b>	
Stabiliser Mounting	0.9, 1.1, 1.3		<b>F8-5132</b>	
Stabiliser Mounting	0.9, 1.1, 1.3		<b>F8-5148</b>	d=16.5; D=125.24
Top Strut Mounting	All Models		<b>F8-5738</b>	
Mounting, axle beam	All Models		<b>F8-6232</b>	H=54; d=10; D=44
Engine Mounting	0.9, 1.1, 1.3		<b>F8-6832</b>	

<b>AK-735014</b>	<b>AK-735025</b>	<b>AK-735027</b>	<b>F5-1103</b>	<b>F5-1140</b>	<b>F8-4013</b>	<b>F8-4026</b>
Ref.Nr.:	Ref.Nr.:	Ref.Nr.:	Ref.Nr.: 070903201C	Ref.Nr.: 059903119L	Ref.Nr.: 052129765A	Ref.Nr.: 817253147
<b>F8-4042</b>	<b>F8-4080</b>	<b>F8-5044</b>	<b>F8-5132</b>	<b>F8-5148</b>	<b>F8-5738</b>	<b>F8-6232</b>
Ref.Nr.: 823407181	Ref.Nr.: 113501149	Ref.Nr.: 861419831B	Ref.Nr.: 861407183	Ref.Nr.: 861411313E	Ref.Nr.: 871412323A	Ref.Nr.: 861511271
<b>F8-6832</b>	<b>F8-7795</b>	<b>F8-7796</b>	<b>F8-7834</b>	<b>F8-7880</b>	<b>F8-7982</b>	<b>F8-8117</b>
Ref.Nr.: 867199383A	Ref.Nr.: 4E0407182B	Ref.Nr.: 8D0407515C	Ref.Nr.: 1K0412303H	Ref.Nr.: 06H105243F	Ref.Nr.: 1K0199868Q	Ref.Nr.: 4E0407183H

**Article Description****Article Nr.****Fitting Position****POLO (86C, 80) 10/1981 → 09/1994**

Dust Cover Kit, shock absorber	0.9, 1.0, 1.0 CAT, 1.1, 1.3, 1.3 CAT, 1.3 D, 1.4 D		AK-735014				
Dust Cover Kit, shock absorber	0.9, 1.0, 1.0 CAT, 1.1, 1.3, 1.3 CAT, 1.3 D, 1.4 D		AK-735025				
Dust Cover Kit, shock absorber	0.9, 1.0, 1.0 CAT, 1.1, 1.3, 1.3 CAT, 1.3 D, 1.4 D		AK-735027				
Flange, carburettor	1.1, 1.3		F8-4013				H1=84; H2=95; d=36; T [mm]=68
Control Arm-/Trailing Arm Bush	0.9, 1.0, 1.0 CAT, 1.1, 1.3, 1.3 CAT, 1.3 D, 1.4 D		F8-4042				H=44; d=10; D1=38; D2=42
Bellow, steering	1.0, 1.0 CAT, 1.3, 1.3 CAT, 1.3 D, 1.4 D		F8-5044				
Stabiliser Mounting	0.9, 1.0, 1.0 CAT, 1.1, 1.3, 1.3 CAT, 1.3 D, 1.4 D		F8-5132				
Stabiliser Mounting	1.0, 1.0 CAT, 1.3, 1.3 CAT, 1.3 D, 1.4 D		F8-5148				d=16.5; D=125.24
Rubber Buffer, suspension	0.9, 1.0, 1.0 CAT, 1.1, 1.3, 1.3 CAT, 1.3 D, 1.4 D		F8-5584				H=112
Top Strut Mounting	All Models		F8-5738				
Mounting, axle beam	0.9, 1.0, 1.0 CAT, 1.1, 1.3, 1.3 CAT, 1.3 D, 1.4 D		F8-6232				H=54; d=10; D=44
Engine Mounting	0.9, 1.0, 1.0 CAT, 1.1, 1.3, 1.3 CAT, 1.4 D		F8-6832				
Engine Mounting	0.9, 1.0, 1.0 CAT, 1.1, 1.3, 1.3 CAT, 1.4 D		F8-6832				
Engine Mounting	0.9, 1.0, 1.0 CAT, 1.1, 1.3, 1.3 CAT, 1.4 D		F8-6832				
Bellow, driveshaft	1.0, 1.0 CAT, 1.3, 1.3 CAT, 1.3 D, 1.4 D		F8-7722				d1=26; d2=78; L=110
Bellow, driveshaft	1.3	MH	F8-7722				d1=26; d2=78; L=110
Bellow, driveshaft	1.3 CAT	2G, AAV, NZ	F8-7722				d1=26; d2=78; L=110
Flange, carburettor	1.0		F8-7744				
Flange, carburettor	1.0 CAT	ACM; not for  AAK, AAU	F8-7744				
Bellow, driveshaft	1.0, 1.0 CAT, 1.3, 1.3 CAT, 1.3 D, 1.4 D		M-830220				
Bellow Set, drive shaft	1.0, 1.0 CAT, 1.3, 1.3 CAT, 1.3 D, 1.4 D		MK-830220				
Bellow Set, drive shaft	1.3	MH	MK-830220				
Bellow Set, drive shaft	1.3 CAT	2G, AAV, NZ	MK-830220				
Bellow Set, drive shaft	1.3 CAT, 1.3 D, 1.4 D		MK-830220S				

**POLO CLASSIC (86C, 80) 01/1985 → 09/1994**

Dust Cover Kit, shock absorber	1.0, 1.3, 1.3 CAT		AK-735002				
Dust Cover Kit, shock absorber	All Models		AK-735014				
Control Arm-/Trailing Arm Bush	1.0, 1.3, 1.3 CAT, 1.3 D		F8-4042				H=44; d=10; D1=38; D2=42
Bellow, driveshaft	1.3		F8-4080				H=95; D1=29; D2=96
Stabiliser Mounting	1.0, 1.3, 1.3 CAT, 1.3 D		F8-5132				
Top Strut Mounting	All Models		F8-5738				
Mounting, axle beam	All Models		F8-6232				H=54; d=10; D=44
Engine Mounting	1.0, 1.3		F8-6832				



Article Description



Article Nr.

Fitting Position



<b>POLO CLASSIC (86C, 80)</b>			<b>01/1985 → 09/1994</b>		
Bellow, driveshaft	1.0	AAU, HZ	<b>F8-7722</b>	⊕ ⊕ ⊕	d1=26; d2=78; L=110
Bellow, driveshaft	1.3 CAT, 1.3 D, 1.4 D		<b>F8-7722</b>	⊕ ⊕ ⊕	d1=26; d2=78; L=110
Flange, carburettor	1.0	HZ; not for  AAK, AAU	<b>F8-7744</b>		
Bellow, driveshaft	1.0, 1.3 CAT, 1.3 D, 1.4 D		<b>M-830220</b>	⊕ ⊕ ⊕	
Bellow Set, drive shaft	1.0	AAU, HZ	<b>MK-830220</b>		
Bellow Set, drive shaft	1.3 CAT, 1.3 D, 1.4 D		<b>MK-830220</b>		
Bellow Set, drive shaft	1.3 D, 1.4 D		<b>MK-830220S</b>		
<b>POLO Coupe (86C, 80)</b>			<b>10/1981 → 09/1994</b>		
Dust Cover Kit, shock absorber	1.0, 1.0 CAT, 1.1, 1.3, 1.3 CAT, 1.3 D, 1.4 D		<b>AK-735002</b>	⊕ ⊕ ⊕	
Dust Cover Kit, shock absorber	1.0, 1.0 CAT, 1.1, 1.3, 1.3 CAT, 1.3 D, 1.3 G40, 1.4 D		<b>AK-735014</b>	⊕ ⊕ ⊕	
Dust Cover Kit, shock absorber	1.0, 1.0 CAT, 1.1, 1.3, 1.3 CAT, 1.3 D, 1.4 D		<b>AK-735027</b>	⊕ ⊕ ⊕	
Flange, carburettor	1.1, 1.3		<b>F8-4013</b>		H1=84; H2=95; d=36; T [mm]=68
Control Arm-/Trailing Arm Bush	1.0, 1.0 CAT, 1.1, 1.3, 1.3 CAT, 1.3 D, 1.4 D		<b>F8-4042</b>		H=44; d=10; D1=38; D2=42
Rubber Buffer, suspension	1.3 G40		<b>F8-4062</b>		H=67; d1=20; d2=24; D=52
Stabiliser Mounting	1.0, 1.0 CAT, 1.1, 1.3, 1.3 CAT, 1.3 D, 1.4 D		<b>F8-5132</b>	⊕ ⊕ ⊕	
Rubber Buffer, suspension	1.0, 1.0 CAT, 1.1, 1.3, 1.3 CAT, 1.3 D, 1.3 G40, 1.4 D		<b>F8-5584</b>	⊕ ⊕ ⊕	H=112
Top Strut Mounting	All Models		<b>F8-5738</b>	⊕ ⊕ ⊕	
Mounting, axle beam	1.0, 1.0 CAT, 1.1, 1.3, 1.3 CAT, 1.3 D, 1.4 D		<b>F8-6232</b>	⊕ ⊕ ⊕	H=54; d=10; D=44
Engine Mounting	1.0, 1.0 CAT, 1.1, 1.3, 1.3 CAT, 1.3 G40, 1.4 D		<b>F8-6832</b>	⊕ ⊕	
Engine Mounting	1.0, 1.0 CAT, 1.1, 1.3, 1.3 CAT, 1.3 G40, 1.4 D		<b>F8-6832</b>	⊕	
Engine Mounting	1.0, 1.0 CAT, 1.1, 1.3, 1.3 CAT, 1.3 G40, 1.4 D		<b>F8-6832</b>		
Engine Mounting	1.3 CAT	01/1991 →;  2G, AAV, NZ	<b>F8-6832</b>	⊕ ⊕	
Bellow, driveshaft	1.0, 1.0 CAT, 1.3, 1.3 CAT, 1.3 D, 1.3 G40, 1.4 D		<b>F8-7722</b>	⊕ ⊕ ⊕	d1=26; d2=78; L=110
Bellow, driveshaft	1.3	MH	<b>F8-7722</b>	⊕ ⊕ ⊕	d1=26; d2=78; L=110
Bellow, driveshaft	1.3 CAT	2G, AAV, NZ	<b>F8-7722</b>	⊕ ⊕ ⊕	d1=26; d2=78; L=110
Flange, carburettor	1.0		<b>F8-7744</b>		
Flange, carburettor	1.0 CAT	ACM; not for  AAK, AAU	<b>F8-7744</b>		
Bellow, driveshaft	1.0, 1.0 CAT, 1.3, 1.3 CAT, 1.3 D, 1.3 G40, 1.4 D		<b>M-830220</b>	⊕ ⊕ ⊕	
Bellow Set, drive shaft	1.0, 1.0 CAT, 1.3, 1.3 CAT, 1.3 D, 1.3 G40, 1.4 D		<b>MK-830220</b>		
Bellow Set, drive shaft	1.3	MH	<b>MK-830220</b>		
Bellow Set, drive shaft	1.3 CAT	2G, AAV, NZ	<b>MK-830220</b>		
Bellow Set, drive shaft	1.3 CAT, 1.3 D, 1.4 D		<b>MK-830220S</b>		

<b>AK-735002</b>	<b>AK-735014</b>	<b>AK-735027</b>	<b>F8-4013</b>	<b>F8-4042</b>	<b>F8-4062</b>	<b>F8-5132</b>
Ref.Nr.:	Ref.Nr.:	Ref.Nr.:	Ref.Nr.: 052129765A	Ref.Nr.: 823407181	Ref.Nr.: 811412131A	Ref.Nr.: 861407183
<b>F8-5584</b>	<b>F8-5738</b>	<b>F8-6232</b>	<b>F8-6832</b>	<b>F8-7722</b>	<b>F8-7744</b>	<b>M-830220</b>
Ref.Nr.: 867512131	Ref.Nr.: 871412323A	Ref.Nr.: 861511271	Ref.Nr.: 867199383A	Ref.Nr.: 191407285F	Ref.Nr.: 030129765	Ref.Nr.: 191498203C
<b>MK-830220</b>	<b>MK-830220S</b>					
Ref.Nr.: 171498203	Ref.Nr.:					

**Article Description****Article Nr.****Fitting Position**

<b>POLO Box (86CF)</b>				<b>08/1992 → 07/1994</b>	
Control Arm-/Trailing Arm Bush	All Models		<b>F8-4042</b>		H=44; d=10; D1=38; D2=42
Stabiliser Mounting	All Models		<b>F8-5132</b>		
Top Strut Mounting	All Models		<b>F8-5738</b>		
Mounting, axle beam	All Models		<b>F8-6232</b>		H=54; d=10; D=44
Repair Kit, suspension strut	All Models		<b>F8-6382</b>		
<b>POLO (6N1)</b>				<b>10/1994 → 10/1999</b>	
Dust Cover Kit, shock absorber	All Models		<b>AK-735028</b>		
Dust Cover Kit, shock absorber	100 1.4 16V, 50 1.0, 55 1.3, 55 1.4, 60 1.4, 60 1.7 SDI		<b>AK-735031</b>		
Dust Cover Kit, shock absorber	All Models	<b>ST</b>	<b>AK-735410</b>		H=210
Alternator Freewheel Clutch	1.7 SDI, 60 1.7 SDI, 64 1.9 D, 64 1.9 SDI		<b>F5-1010</b>		
Alternator Freewheel Clutch	60 1.7 SDI, 64 1.9 D, 64 1.9 SDI		<b>F5-1011</b>		
Control Arm-/Trailing Arm Bush	1.7 SDI, 100 1.4 16V, 120 1.6 16V GTI, 50 1.0, 55 1.3, 64 1.9 SDI	without guide sleeve	<b>F8-1007</b>		H1=26; H2=41; d=17; D1=60; D2=68
Control Arm-/Trailing Arm Bush	45 1.0, 55 1.4, 60 1.4, 64 1.9 D, 75 1.6	01/1996 →; without guide sleeve	<b>F8-1007</b>		H1=26; H2=41; d=17; D1=60; D2=68
Control Arm-/Trailing Arm Bush	60 1.7 SDI	06/1997 →; without guide sleeve	<b>F8-1007</b>		H1=26; H2=41; d=17; D1=60; D2=68
Control Arm-/Trailing Arm Bush	All Models	with guide sleeve	<b>F8-1007S</b>		H1=26; H2=41; d=17; D1=60; D2=68
Anti-Friction Bearing	All Models		<b>F8-3039</b>		H=14; d1=14; D=45
Holder, exhaust system	100 1.4 16V, 45 1.0, 50 1.0, 55 1.3, 60 1.4, 60 1.7 SDI, 64 1.9 D, 75 1.6		<b>F8-4025</b>		H=65; T [mm]=86; W=35
Bellow, steering	100 1.4 16V, 120 1.6 16V GTI, 45 1.0, 50 1.0, 55 1.3, 60 1.4, 60 1.7 SDI, 64 1.9 D, 75 1.6		<b>F8-5061</b>		
Control Arm-/Trailing Arm Bush	100 1.4 16V, 120 1.6 16V GTI, 45 1.0, 50 1.0, 55 1.3, 55 1.4, 60 1.4, 60 1.7 SDI, 64 1.9 D, 64 1.9 SDI, 75 1.6		<b>F8-5104</b>		H=47; d=10; D=28
Control Arm-/Trailing Arm Bush	100 1.4 16V, 120 1.6 16V GTI, 45 1.0, 50 1.0, 55 1.3, 55 1.4, 60 1.4, 60 1.7 SDI, 64 1.9 D, 64 1.9 SDI, 75 1.6		<b>F8-5105</b>		H=46; d=17; D=61
Mounting, axle beam	100 1.4 16V, 120 1.6 16V GTI, 45 1.0, 50 1.0, 55 1.3, 55 1.4, 60 1.4, 60 1.7 SDI, 64 1.9 D, 64 1.9 SDI, 75 1.6		<b>F8-5341</b>		H=58; d=10; D=58
Repair Set, axle beam	100 1.4 16V, 120 1.6 16V GTI, 45 1.0, 50 1.0, 55 1.3, 55 1.4, 60 1.4, 60 1.7 SDI, 64 1.9 D, 64 1.9 SDI, 75 1.6		<b>F8-5341S</b>		d=10; D=58
Top Strut Mounting	1.7 SDI, 100 1.4 16V, 120 1.6 16V GTI, 50 1.0, 55 1.4, 64 1.9 SDI	ch.→6N-Y-050000	<b>F8-5402</b>		
Top Strut Mounting	45 1.0, 55 1.3		<b>F8-5402</b>		
Top Strut Mounting	60 1.4	ch.→6N-Y-050000;  AEX, APQ	<b>F8-5402</b>		
Top Strut Mounting	60 1.7 SDI, 64 1.9 D	ch.→6N-2-010000	<b>F8-5402</b>		
Top Strut Mounting	75 1.6	ch.→6N-Y-050000;  AEA, AEE	<b>F8-5402</b>		
Top Strut Mounting	1.7 SDI, 100 1.4 16V, 120 1.6 16V GTI, 50 1.0, 55 1.4, 60 1.4, 60 1.7 SDI, 64 1.9 SDI		<b>F8-5403</b>		

<b>AK-735028</b>	<b>AK-735031</b>	<b>AK-735410</b>	<b>F5-1010</b>	<b>F5-1011</b>	<b>F8-1007</b>	<b>F8-1007S</b>
Ref.Nr.:	Ref.Nr.:	Ref.Nr.: 1J0412303	Ref.Nr.: 028903119S	Ref.Nr.: 038903119Q	Ref.Nr.: 191407181A	Ref.Nr.: 191407181A
<b>F8-3039</b>	<b>F8-4025</b>	<b>F8-4042</b>	<b>F8-5061</b>	<b>F8-5104</b>	<b>F8-5105</b>	<b>F8-5132</b>
Ref.Nr.: 357412249A	Ref.Nr.: 1H0253144	Ref.Nr.: 823407181	Ref.Nr.: 6N0419831	Ref.Nr.: 6N0407182	Ref.Nr.: 6N0407181	Ref.Nr.: 861407183
<b>F8-5341</b>	<b>F8-5341S</b>	<b>F8-5402</b>	<b>F8-5403</b>	<b>F8-5738</b>	<b>F8-6232</b>	<b>F8-6382</b>
Ref.Nr.: 6N0501541D	Ref.Nr.: 6N0501541D	Ref.Nr.: 191512335	Ref.Nr.: 191512333	Ref.Nr.: 871412323A	Ref.Nr.: 861511271	Ref.Nr.: 191512333S

**Article Description**

**Article Nr.**
**Fitting Position**

**POLO (6N1) 10/1994 → 10/1999**

Top Strut Mounting	45 1.0, 55 1.3, 64 1.9 D, 75 1.6	01/1995 →	F8-5403		
Top Strut Mounting	All Models		F8-5494		d=26; D=83
Top Strut Mounting	All Models		F8-5523		
Top Strut Mounting	All Models		F8-5537		
Engine Mounting	45 1.0	ch.6N-TW000001, 6N-TY000001 →;	F8-5540		
Engine Mounting	50 1.0, 55 1.3, 55 1.4, 60 1.4, 75 1.6		F8-5540		
Protective Cap/Bellow, shock absorber	All Models		F8-5683		H=210
Rubber Buffer, suspension	All Models		F8-5996		H=63
Rubber Buffer, suspension	All Models	ch.→6N-W-098090	F8-6004		H=133
Rubber Buffer, suspension	All Models	ch.6N-W-098091 →	F8-6006		H=100
Stabiliser Mounting	All Models	Stabi. Diam. [mm]= 18	F8-6190		d=16
Stabiliser Mounting	All Models	for OE: 0AD / 0AH; Stabi. Diam. [mm]= 20, 22	F8-6191		d=18
Repair Kit, suspension strut	All Models		F8-6382		
Belt Pulley, crankshaft	1.7 SDI, 60 1.7 SDI, 64 1.9 SDI	Number of Ribs: 5	F8-6398		
Belt Pulley, crankshaft	64 1.9 D	ch.→6N-SW150000, 6N-SY300000; Number of Ribs: 5	F8-6398		
Engine Mounting	45 1.0, 50 1.0, 55 1.3, 55 1.4, 60 1.4		F8-6501		
Engine Mounting	64 1.9 D	ch.→6N-WW058709, 6N-WY065354;	F8-6501		
Engine Mounting	75 1.6	AEA, AEE;	F8-6501		
Engine Mounting	120 1.6 16V GTI, 50 1.0	ch.→6N-Y-050000;	F8-6923		
Engine Mounting	45 1.0, 55 1.3	ch.6N-T-000001 →;	F8-6923		
Engine Mounting	55 1.4, 60 1.4	ch.6N-T-000001 →; ch.→6N-Y-050000;	F8-6923		
Engine Mounting	75 1.6	ch.6N-T-000001 →; ch.→6N-Y-050000;  AEA, AEE;	F8-6923		
Bellow, driveshaft	1.7 SDI, 100 1.4 16V, 45 1.0, 50 1.0, 55 1.3, 55 1.4, 60 1.4, 60 1.7 SDI, 64 1.9 D, 64 1.9 SDI, 75 1.6		F8-7722		d1=26; d2=78; L=110
Engine Mounting	100 1.4 16V, 120 1.6 16V GTI		F8-7948		
Engine Mounting	100 1.4 16V, 60 1.7 SDI, 64 1.9 D, 64 1.9 SDI		F8-8189		
Bellow, steering	All Models	with clamps	LM-10063S		d1=11; d2=42; L [mm]=208
Bellow, steering	All Models	with clamps;	LM-10088S		d1=25; d2=40; L [mm]=143

**POLO Saloon (6KV2) 11/1995 → 07/2002**

Dust Cover Kit, shock absorber	100 1.6, 110 1.9 TDI, 57 1.7 SDI, 60 1.4, 64 1.9 SDI, 68 1.9 SDI, 75 1.4 16V, 75 1.6, 90 1.8, 90 1.9 TDI		AK-733023		
Dust Cover Kit, shock absorber	100 1.6, 60 1.4, 64 1.9 SDI, 75 1.6	01/1996 →	AK-735029		

<b>AK-733023</b>	<b>AK-735029</b>	<b>F8-5403</b>	<b>F8-5494</b>	<b>F8-5523</b>	<b>F8-5537</b>	<b>F8-5540</b>
Ref.Nr.: 191412303	Ref.Nr.:	Ref.Nr.: 191512333	Ref.Nr.: 6N0412331	Ref.Nr.: 6N0412331A	Ref.Nr.: 6N0412331E	Ref.Nr.: 6N0199262L
<b>F8-5683</b>	<b>F8-5996</b>	<b>F8-6004</b>	<b>F8-6006</b>	<b>F8-6190</b>	<b>F8-6191</b>	<b>F8-6382</b>
Ref.Nr.: 357413175A	Ref.Nr.: 1H0412303B	Ref.Nr.: 6N0512131A	Ref.Nr.: 6K0512131A	Ref.Nr.: 6X0411313	Ref.Nr.: 6X0411313A	Ref.Nr.: 191512333S
<b>F8-6398</b>	<b>F8-6501</b>	<b>F8-6923</b>	<b>F8-7722</b>	<b>F8-7948</b>	<b>F8-8189</b>	<b>LM-10063S</b>
Ref.Nr.: 028 105 243AC	Ref.Nr.: 6N0 199 851 AG	Ref.Nr.: 6N0199555AA	Ref.Nr.: 191407285F	Ref.Nr.: 6N0199262G	Ref.Nr.: 6N0199555H	Ref.Nr.: 6N0422831



**Article Description****Article Nr.****Fitting Position**

<b>POLO Saloon (6KV2)</b>		<b>11/1995 → 07/2002</b>	
Dust Cover Kit, shock absorber	110 1.9 TDI, 57 1.7 SDI, 64 1.9 D, 68 1.9 SDI, 75 1.4 16V, 75 1.6, 90 1.8, 90 1.9 TDI		<b>AK-735029</b>
Dust Cover Kit, shock absorber	1.4, 1.8, 1.9 SDI, 100 1.6, 110 1.9 TDI, 54 1.4, 57 1.7 SDI, 60 1.4, 64 1.9 D, 64 1.9 SDI, 68 1.9 SDI, 75 1.4 16V, 75 1.6, 90 1.8, 90 1.9 TDI	<b>ST</b>	<b>AK-735410</b>
Alternator Freewheel Clutch	68 1.9 SDI, 90 1.9 TDI		<b>F5-1004</b>
Alternator Freewheel Clutch	1.9 SDI, 110 1.9 TDI, 57 1.7 SDI, 64 1.9 SDI, 90 1.9 TDI		<b>F5-1007</b>
Control Arm-/Trailing Arm Bush	100 1.6, 60 1.4, 64 1.9 SDI, 75 1.6	01/1996 →; without guide sleeve	<b>F8-1007</b>
Control Arm-/Trailing Arm Bush	110 1.9 TDI, 57 1.7 SDI, 68 1.9 SDI, 75 1.4 16V, 75 1.6, 90 1.8, 90 1.9 TDI	without guide sleeve	<b>F8-1007</b>
Control Arm-/Trailing Arm Bush	100 1.6, 110 1.9 TDI, 57 1.7 SDI, 60 1.4, 64 1.9 SDI, 68 1.9 SDI, 75 1.4 16V, 75 1.6, 90 1.8, 90 1.9 TDI	with guide sleeve	<b>F8-1007S</b>
Repair Kit, link	100 1.6, 60 1.4, 64 1.9 SDI, 75 1.6	01/1996 →; with guide sleeve	<b>F8-1008</b>
Repair Kit, link	110 1.9 TDI, 57 1.7 SDI, 68 1.9 SDI, 75 1.4 16V, 90 1.8, 90 1.9 TDI	with guide sleeve	<b>F8-1008</b>
Top Strut Mounting	60 1.4		<b>F8-1009B</b>
Engine Mounting	75 1.6, 90 1.9 TDI		<b>F8-1011</b>
Engine Mounting	100 1.6, 64 1.9 D, 75 1.6		<b>F8-1015</b>
Top Strut Mounting	100 1.6, 57 1.7 SDI, 60 1.4, 64 1.9 SDI, 75 1.6, 90 1.9 TDI		<b>F8-1034</b>
Top Strut Mounting	100 1.6, 57 1.7 SDI, 60 1.4, 64 1.9 SDI, 75 1.6, 90 1.9 TDI		<b>F8-1034S</b>
Anti-Friction Bearing	1.4, 1.9 SDI, 100 1.6, 110 1.9 TDI, 54 1.4, 57 1.7 SDI, 60 1.4, 64 1.9 SDI, 68 1.9 SDI, 75 1.4 16V, 75 1.6, 90 1.8, 90 1.9 TDI		<b>F8-3039</b>
Stabiliser Mounting	100 1.6, 110 1.9 TDI, 54 1.4, 57 1.7 SDI, 60 1.4, 64 1.9 D, 64 1.9 SDI, 75 1.4 16V, 75 1.6, 90 1.8, 90 1.9 TDI		<b>F8-3042</b>
Flange, carburettor	75 1.6		<b>F8-3048</b>
Engine Mounting	64 1.9 D, 64 1.9 SDI		<b>F8-3053</b>
Engine Mounting	100 1.6, 64 1.9 SDI		<b>F8-4016</b>
Engine Mounting	60 1.4		<b>F8-4017</b>
Bellow, driveshaft	100 1.6, 110 1.9 TDI, 57 1.7 SDI, 60 1.4, 64 1.9 SDI, 68 1.9 SDI, 75 1.4 16V, 75 1.6, 90 1.8, 90 1.9 TDI		<b>F8-4080</b>
Engine Mounting	100 1.6	Brown;  AFT	<b>F8-5346</b>
Engine Mounting	75 1.4 16V	Brown;  APE	<b>F8-5346</b>
Mounting, steering gear	100 1.6, 110 1.9 TDI, 54 1.4, 57 1.7 SDI, 60 1.4, 64 1.9 D, 64 1.9 SDI, 68 1.9 SDI, 75 1.4 16V, 75 1.6, 90 1.8, 90 1.9 TDI		<b>F8-5394</b>
Stabiliser Mounting	100 1.6	ch.6K-Y-502795→	<b>F8-5395</b>

<b>AK-735029</b>	<b>AK-735410</b>	<b>F5-1004</b>	<b>F5-1007</b>	<b>F8-1007</b>	<b>F8-1007S</b>	<b>F8-1008</b>
Ref.Nr.:	Ref.Nr.: 1J0412303	Ref.Nr.: 038903119T	Ref.Nr.: 028903119AQ	Ref.Nr.: 191407181A	Ref.Nr.: 191407181A	Ref.Nr.: 191407181E
<b>F8-1009B</b>	<b>F8-1011</b>	<b>F8-1015</b>	<b>F8-1034</b>	<b>F8-1034S</b>	<b>F8-3039</b>	<b>F8-3042</b>
Ref.Nr.: 176412329	Ref.Nr.: 1H0199262F	Ref.Nr.: 357199402	Ref.Nr.: 357412331A	Ref.Nr.: 7201848S1	Ref.Nr.: 357412249A	Ref.Nr.: 191411314
<b>F8-3048</b>	<b>F8-3053</b>	<b>F8-4016</b>	<b>F8-4017</b>	<b>F8-4080</b>	<b>F8-5346</b>	<b>F8-5394</b>
Ref.Nr.: 050129761B	Ref.Nr.: 1H0199609B	Ref.Nr.: 1H0199262G	Ref.Nr.: 1H0199262E	Ref.Nr.: 113501149	Ref.Nr.: 1H0199609G	Ref.Nr.: 1H0422884

Article Description



Article Nr.

Fitting Position



**POLO Saloon (6KV2)**

11/1995 → 07/2002

Stabiliser Mounting	110 1.9 TDI, 68 1.9 SDI		<b>F8-5395</b>		d=19
Stabiliser Mounting	57 1.7 SDI, 64 1.9 D, 64 1.9 SDI, 90 1.8, 90 1.9 TDI	ch.6K-V-047501→	<b>F8-5395</b>		d=19
Engine Mounting	90 1.9 TDI	01/1997 →;  AHU	<b>F8-5396</b>		
Engine Mounting	75 1.6, 90 1.8		<b>F8-5397</b>		
Engine Mounting	60 1.4	AEX, AKK, AKV, ANW, ANX, APQ	<b>F8-5398</b>		
Top Strut Mounting	100 1.6, 110 1.9 TDI, 57 1.7 SDI, 64 1.9 SDI, 68 1.9 SDI, 75 1.4 16V, 75 1.6, 90 1.9 TDI		<b>F8-5402</b>		
Top Strut Mounting	60 1.4	AEX, AKK, AKV, ANW, APQ, AUD	<b>F8-5402</b>		
Top Strut Mounting	100 1.6, 60 1.4, 64 1.9 SDI, 75 1.6	01/1996 →	<b>F8-5403</b>		
Top Strut Mounting	110 1.9 TDI, 57 1.7 SDI, 68 1.9 SDI, 75 1.4 16V, 90 1.9 TDI		<b>F8-5403</b>		
Engine Mounting	110 1.9 TDI, 90 1.9 TDI		<b>F8-5491</b>		
Top Strut Mounting	100 1.6, 110 1.9 TDI, 57 1.7 SDI, 60 1.4, 75 1.6, 90 1.9 TDI	01/2000 →;	<b>F8-5537</b>		
Top Strut Mounting	54 1.4, 64 1.9 D, 75 1.6	ch.6K-Y-502795→;	<b>F8-5537</b>		
Top Strut Mounting	64 1.9 SDI, 68 1.9 SDI, 75 1.4 16V, 90 1.8		<b>F8-5537</b>		
Engine Mounting	60 1.4, 64 1.9 SDI, 75 1.6, 90 1.8		<b>F8-5554</b>		H=39.5; d1=16; d2=24; D=50
Engine Mounting	75 1.4 16V	APE	<b>F8-5554</b>		H=39.5; d1=16; d2=24; D=50
Belt Pulley, crankshaft	110 1.9 TDI, 57 1.7 SDI, 64 1.9 D, 64 1.9 SDI, 90 1.9 TDI	Number of Ribs: 5; Parameter: 6PK	<b>F8-5649</b>		H=31.5; d=30.02; Mounting points diam.[mm]=8.5; D1=161.5; D2=160.5
Holder, engine mounting	100 1.6, 64 1.9 SDI, 90 1.9 TDI		<b>F8-5672</b>		H=39.5; D=24
Protective Cap/Bellow, shock absorber	1.4, 1.8, 1.9 SDI, 100 1.6, 110 1.9 TDI, 54 1.4, 57 1.7 SDI, 60 1.4, 64 1.9 D, 64 1.9 SDI, 68 1.9 SDI, 75 1.4 16V, 75 1.6, 90 1.8, 90 1.9 TDI		<b>F8-5683</b>		H=210
Rubber Buffer, suspension	100 1.6, 110 1.9 TDI, 54 1.4, 57 1.7 SDI, 60 1.4, 64 1.9 D, 64 1.9 SDI, 68 1.9 SDI, 75 1.4 16V, 75 1.6, 90 1.8, 90 1.9 TDI		<b>F8-6004</b>		H=133
Rubber Buffer, suspension	100 1.6, 54 1.4, 60 1.4, 68 1.9 SDI, 75 1.4 16V	ch.→6K-Y-504288	<b>F8-6006</b>		H=100
Rubber Buffer, suspension	110 1.9 TDI, 57 1.7 SDI, 64 1.9 D, 64 1.9 SDI, 75 1.6, 90 1.8, 90 1.9 TDI		<b>F8-6006</b>		H=100
Rubber Buffer, suspension	100 1.6, 60 1.4, 68 1.9 SDI, 75 1.4 16V	ch.6K-Y-504289→	<b>F8-6008</b>		H=95
Repair Kit, suspension strut	100 1.6, 110 1.9 TDI, 57 1.7 SDI, 60 1.4, 64 1.9 D, 64 1.9 SDI, 68 1.9 SDI, 75 1.4 16V, 75 1.6, 90 1.8, 90 1.9 TDI		<b>F8-6382</b>		
Sleeve, control arm mounting	100 1.6, 110 1.9 TDI, 57 1.7 SDI, 60 1.4, 64 1.9 D, 64 1.9 SDI, 68 1.9 SDI, 75 1.4 16V, 75 1.6, 90 1.8, 90 1.9 TDI		<b>F8-6699</b>		d=16; L=50; D=17
Engine Mounting	57 1.7 SDI, 64 1.9 SDI	ch.→6K-Y-502794	<b>F8-6922</b>		H=65
Engine Mounting	60 1.4	AEX, AKK, AKV, ANW, APQ, AUD	<b>F8-6922</b>		H=65



**Article Description****Article Nr.****Fitting Position****POLO Saloon (6KV2) 11/1995 → 07/2002**

Engine Mounting	68 1.9 SDI		<b>F8-6922</b>		H=65
Engine Mounting	75 1.6	ch.→6K-Y-502794; 01/1997 →;  AEE	<b>F8-6922</b>		H=65
Bellow, driveshaft	60 1.4	AEX	<b>F8-7722</b>		d1=26; d2=78; L=110
Mounting, axle beam	1.4, 68 1.9 SDI, 75 1.4 16V	ch.6K-X-610001→	<b>F8-7938</b>		H=80; D=72
Mounting, axle beam	100 1.6	ch.6K-X-610001→;  AEH	<b>F8-7938</b>		H=80; D=72
Mounting, axle beam	100 1.6	ch.6K-X-610001→;  AKL	<b>F8-7938</b>		H=80; D=72
Mounting, axle beam	110 1.9 TDI	ch.6K-X-610001→;  ASV	<b>F8-7938</b>		H=80; D=72
Mounting, axle beam	60 1.4	ch.6K-X-610001→;  AKK	<b>F8-7938</b>		H=80; D=72
Mounting, axle beam	60 1.4	ch.6K-X-610001→;  ANW	<b>F8-7938</b>		H=80; D=72
Mounting, axle beam	75 1.6	ch.6K-X-610001→;  ALM	<b>F8-7938</b>		H=80; D=72
Mounting, axle beam	90 1.8	ch.6K-X-610001→;  ADD	<b>F8-7938</b>		H=80; D=72
Mounting, axle beam	90 1.9 TDI	ch.6K-X-610001→;  AGR	<b>F8-7938</b>		H=80; D=72
Mounting, axle beam	90 1.9 TDI	ch.6K-X-610001→;  ALH	<b>F8-7938</b>		H=80; D=72
Control Arm-/Trailing Arm Bush	1.4, 1.8, 1.9 SDI, 100 1.6, 110 1.9 TDI, 54 1.4, 57 1.7 SDI, 60 1.4, 64 1.9 D, 64 1.9 SDI, 68 1.9 SDI, 75 1.4 16V, 75 1.6, 90 1.9 TDI		<b>F8-7978</b>		
Control Arm-/Trailing Arm Bush	100 1.6, 110 1.9 TDI, 57 1.7 SDI, 60 1.4, 64 1.9 SDI, 68 1.9 SDI, 75 1.4 16V, 75 1.6, 90 1.8, 90 1.9 TDI		<b>G9-648</b>		H=54; d=12; D1=33; D2=36
Bellow, steering	1.4, 1.8, 1.9 SDI, 100 1.6, 110 1.9 TDI, 54 1.4, 57 1.7 SDI, 60 1.4, 64 1.9 D, 64 1.9 SDI, 68 1.9 SDI, 75 1.4 16V, 75 1.6, 90 1.8, 90 1.9 TDI	with clamps;	<b>LM-10003S</b>		d1=9; d2=43; L [mm]=210
Bellow, steering	1.4, 1.8, 1.9 SDI, 100 1.6, 110 1.9 TDI, 54 1.4, 57 1.7 SDI, 60 1.4, 64 1.9 D, 64 1.9 SDI, 68 1.9 SDI, 75 1.4 16V, 75 1.6, 90 1.8, 90 1.9 TDI	with clamps	<b>LM-10006S</b>		d1=10; d2=41; L [mm]=210
Bellow, driveshaft	60 1.4		<b>M-830220</b>		
Bellow Set, drive shaft	60 1.4	AEX	<b>MK-830220</b>		

**POLO Box (6NF) 10/1994 → 12/1999**

Dust Cover Kit, shock absorber	All Models		<b>AK-733023</b>		
Alternator Freewheel Clutch	1.7 SDI, 1.9 D, 1.9 SDI		<b>F5-1010</b>		
Alternator Freewheel Clutch	1.7 SDI, 1.9 D, 1.9 SDI		<b>F5-1011</b>		
Anti-Friction Bearing	All Models		<b>F8-3039</b>		H=14; d1=14; D=45
Control Arm-/Trailing Arm Bush	All Models		<b>F8-5104</b>		H=47; d=10; D=28
Control Arm-/Trailing Arm Bush	All Models		<b>F8-5105</b>		H=46; d=17; D=61
Top Strut Mounting	All Models		<b>F8-5523</b>		
Top Strut Mounting	All Models		<b>F8-5537</b>		
Repair Kit, suspension strut	All Models		<b>F8-6382</b>		

<b>AK-733023</b>	<b>F5-1010</b>	<b>F5-1011</b>	<b>F8-3039</b>	<b>F8-5104</b>	<b>F8-5105</b>	<b>F8-5523</b>
Ref.Nr.: 191412303	Ref.Nr.: 028903119S	Ref.Nr.: 038903119Q	Ref.Nr.: 357412249A	Ref.Nr.: 6N0407182	Ref.Nr.: 6N0407181	Ref.Nr.: 6N0412331A
<b>F8-5537</b>	<b>F8-6382</b>	<b>F8-6922</b>	<b>F8-7722</b>	<b>F8-7938</b>	<b>F8-7978</b>	<b>G9-648</b>
Ref.Nr.: 6N0412331E	Ref.Nr.: 191512333S	Ref.Nr.: 191199381A	Ref.Nr.: 191407285F	Ref.Nr.: 6K0501541A	Ref.Nr.: 357407182F	Ref.Nr.: 357407182
<b>LM-10003S</b>	<b>LM-10006S</b>	<b>M-830220</b>	<b>MK-830220</b>			
Ref.Nr.: 357422831A	Ref.Nr.: 1H0422831B	Ref.Nr.: 191498203C	Ref.Nr.: 171498203			

Article Description



Article Nr.

Fitting Position



**POLO Variant (6KV5)**

05/1997 → 09/2001

Article Description	Article Nr.	Fitting Position	Technical Data
Dust Cover Kit, shock absorber	AK-733023		
Dust Cover Kit, shock absorber	AK-735029		
Dust Cover Kit, shock absorber	AK-735410		H=210
Alternator Freewheel Clutch	F5-1004		
Alternator Freewheel Clutch	F5-1007		
Control Arm-/Trailing Arm Bush	F8-1007		H1=26; H2=41; d=17; D1=60; D2=68
Control Arm-/Trailing Arm Bush	F8-1007S		H1=26; H2=41; d=17; D1=60; D2=68
Repair Kit, link	F8-1008		H1=24; H2=41; d=17; D=60
Top Strut Mounting	F8-1009B		d=14; D=132
Engine Mounting	F8-1011		H=133; D1=80; D2=108
Engine Mounting	F8-1015		H=82; D1=55; D2=71
Top Strut Mounting	F8-1034		H=50; d=27; D=98
Top Strut Mounting	F8-1034S		H=51; d=14; D=96
Anti-Friction Bearing	F8-3039		H=14; d1=14; D=45
Stabiliser Mounting	F8-3042		H=33; d=17; W=35
Engine Mounting	F8-3053		H=135; D1=79; D2=93
Engine Mounting	F8-4016		
Engine Mounting	F8-4017		
Engine Mounting	F8-5346		
Engine Mounting	F8-5346		
Mounting, steering gear	F8-5394		
Stabiliser Mounting	F8-5395		d=19
Stabiliser Mounting	F8-5395		d=19
Engine Mounting	F8-5396		
Engine Mounting	F8-5397		
Engine Mounting	F8-5398		
Top Strut Mounting	F8-5402		
Top Strut Mounting	F8-5402		
Top Strut Mounting	F8-5403		
Engine Mounting	F8-5491		
Top Strut Mounting	F8-5537		
Top Strut Mounting	F8-5537		
Top Strut Mounting	F8-5537		
Engine Mounting	F8-5554		H=39.5; d1=16; d2=24; D=50



**Article Description****Article Nr.****Fitting Position**

<b>POLO Variant (6KV5)</b>			<b>05/1997 → 09/2001</b>		
Engine Mounting	1.4, 1.6, 1.8		<b>F8-5554</b>		H=39.5; d1=16; d2=24; D=50
Belt Pulley, crankshaft	1.7 SDI, 1.9 SDI, 1.9 TDI	Number of Ribs: 5; Parameter: 6PK	<b>F8-5649</b>		H=31.5; d=30.02; Mounting points diam.[mm]=8.5; D1=161.5; D2=160.5
Holder, engine mounting	1.6, 1.9 SDI, 1.9 TDI		<b>F8-5672</b>		H=39.5; D=24
Protective Cap/Bellow, shock absorber	All Models		<b>F8-5683</b>		H=210
Rubber Buffer, suspension	1.4, 1.4 16V, 1.6, 1.7 SDI, 1.9 SDI, 1.9 TDI		<b>F8-6004</b>		H=133
Rubber Buffer, suspension	1.4, 1.4 16V, 1.6, 1.9 SDI	ch.→6K-X-610000	<b>F8-6006</b>		H=100
Rubber Buffer, suspension	1.6, 1.7 SDI, 1.9 SDI, 1.9 TDI		<b>F8-6006</b>		H=100
Rubber Buffer, suspension	1.4, 1.4 16V, 1.6, 1.9 SDI	ch.6K-X-610000→	<b>F8-6008</b>		H=95
Repair Kit, suspension strut	All Models		<b>F8-6382</b>		
Anti-Friction Bearing	1.8		<b>F8-6569</b>		
Sleeve, control arm mounting	All Models		<b>F8-6699</b>		d=16; L=50; D=17
Engine Mounting	1.4, 1.9 SDI		<b>F8-6922</b>		H=65
Engine Mounting	1.6	ch.→6K-Y-502794;  AEE	<b>F8-6922</b>		H=65
Engine Mounting	1.7 SDI, 1.9 SDI	ch.→6K-Y-502794	<b>F8-6922</b>		H=65
Protective Cap/Bellow, shock absorber	All Models		<b>F8-7132</b>		H=190
Bellow, driveshaft	1.4	AEX	<b>F8-7722</b>		d1=26; d2=78; L=110
Mounting, axle beam	1.4	ch.6K-X-610001→;  AKK	<b>F8-7938</b>		H=80; D=72
Mounting, axle beam	1.4	ch.6K-X-610001→;  ANW	<b>F8-7938</b>		H=80; D=72
Mounting, axle beam	1.4, 1.4 16V, 1.8, 1.9 SDI	ch.6K-X-610001→	<b>F8-7938</b>		H=80; D=72
Mounting, axle beam	1.6	ch.6K-X-610001→;  AEH	<b>F8-7938</b>		H=80; D=72
Mounting, axle beam	1.6	ch.6K-X-610001→;  AKL	<b>F8-7938</b>		H=80; D=72
Mounting, axle beam	1.6	ch.6K-X-610001→;  ALM	<b>F8-7938</b>		H=80; D=72
Mounting, axle beam	1.9 TDI	ch.6K-X-610001→;  AGR	<b>F8-7938</b>		H=80; D=72
Mounting, axle beam	1.9 TDI	ch.6K-X-610001→;  ALH	<b>F8-7938</b>		H=80; D=72
Mounting, axle beam	1.9 TDI	ch.6K-X-610001→;  ASV	<b>F8-7938</b>		H=80; D=72
Control Arm-/Trailing Arm Bush	All Models		<b>F8-7978</b>		
Control Arm-/Trailing Arm Bush	All Models		<b>G9-648</b>		H=54; d=12; D1=33; D2=36
Bellow, driveshaft	1.4		<b>M-830220</b>		
Bellow Set, drive shaft	1.4	AEX	<b>MK-830220</b>		
<b>POLO (6N2)</b>			<b>10/1999 → 09/2001</b>		
Dust Cover Kit, shock absorber	All Models		<b>AK-735004</b>		

<b>AK-735004</b>	<b>AK-735028</b>	<b>F8-5554</b>	<b>F8-5649</b>	<b>F8-5672</b>	<b>F8-5683</b>	<b>F8-6004</b>
Ref.Nr.:	Ref.Nr.:	Ref.Nr.: 191199233	Ref.Nr.: 028105243T	Ref.Nr.: 1H0199233A	Ref.Nr.: 357413175A	Ref.Nr.: 6N0512131A
<b>F8-6006</b>	<b>F8-6008</b>	<b>F8-6382</b>	<b>F8-6569</b>	<b>F8-6699</b>	<b>F8-6922</b>	<b>F8-7132</b>
Ref.Nr.: 6K0512131A	Ref.Nr.: 6K0512131B	Ref.Nr.: 191512333S	Ref.Nr.: 6N0412249C	Ref.Nr.: 191407190A	Ref.Nr.: 191199381A	Ref.Nr.: 6N0413175A
<b>F8-7722</b>	<b>F8-7938</b>	<b>F8-7978</b>	<b>G9-648</b>	<b>M-830220</b>	<b>MK-830220</b>	
Ref.Nr.: 191407285F	Ref.Nr.: 6K0501541A	Ref.Nr.: 357407182F	Ref.Nr.: 357407182	Ref.Nr.: 191498203C	Ref.Nr.: 171498203	

Article Description



Article Nr.

Fitting Position



POLO (6N2)			10/1999 → 09/2001	
Dust Cover Kit, shock absorber	All Models		AK-735028	
Dust Cover Kit, shock absorber	All Models	ST	AK-735410	H=210
Alternator Freewheel Clutch	1.4 TDI, 1.7 SDI, 1.9 D, 1.9 SDI		F5-1004	
Alternator Freewheel Clutch	1.7 SDI, 1.9 D, 1.9 SDI		F5-1010	
Alternator Freewheel Clutch	1.7 SDI, 1.9 D, 1.9 SDI		F5-1011	
Control Arm-/Trailing Arm Bush	1.0, 1.4, 1.4 16V, 1.4 TDI, 1.6 16V GTI, 1.9 D	without guide sleeve	F8-1007	H1=26; H2=41; d=17; D1=60; D2=68
Control Arm-/Trailing Arm Bush	1.0, 1.4, 1.4 16V, 1.4 TDI, 1.6 16V GTI, 1.9 D	with guide sleeve	F8-1007S	H1=26; H2=41; d=17; D1=60; D2=68
Control Arm-/Trailing Arm Bush	1.0, 1.4, 1.4 16V, 1.4 TDI, 1.6 16V GTI, 1.7 SDI, 1.9 D, 1.9 SDI		F8-5104	H=47; d=10; D=28
Control Arm-/Trailing Arm Bush	1.0, 1.4, 1.4 16V, 1.4 TDI, 1.6 16V GTI, 1.7 SDI, 1.9 D, 1.9 SDI		F8-5105	H=46; d=17; D=61
Mounting, axle beam	1.0, 1.4, 1.4 16V, 1.4 TDI, 1.6 16V GTI, 1.7 SDI, 1.9 SDI		F8-5341	H=58; d=10; D=58
Repair Set, axle beam	1.0, 1.4, 1.4 16V, 1.4 TDI, 1.6 16V GTI, 1.7 SDI, 1.9 SDI		F8-5341S	d=10; D=58
Top Strut Mounting	1.0, 1.4, 1.4 16V, 1.4 TDI, 1.6 16V GTI, 1.9 SDI	ch.6N-Y-500001→; ch.→6N-2-010000	F8-5402	
Top Strut Mounting	1.7 SDI, 1.9 D	ch.→6N-2-010000	F8-5402	
Top Strut Mounting	1.0, 1.4, 1.4 16V, 1.4 TDI, 1.6 16V GTI, 1.7 SDI, 1.9 D, 1.9 SDI		F8-5403	
Top Strut Mounting	1.0, 1.4, 1.4 16V, 1.4 TDI, 1.6 16V GTI, 1.7 SDI, 1.9 SDI		F8-5494	d=26; D=83
Top Strut Mounting	1.0, 1.4, 1.4 16V, 1.4 TDI, 1.6 16V GTI, 1.7 SDI, 1.9 SDI		F8-5523	
Top Strut Mounting	1.0, 1.4, 1.4 16V, 1.4 TDI, 1.6 16V GTI, 1.7 SDI, 1.9 SDI	01/2000 →;	F8-5537	
Top Strut Mounting	1.4 TDI, 1.9 D		F8-5537	
Engine Mounting	1.0, 1.4		F8-5540	
Protective Cap/Bellow, shock absorber	All Models		F8-5683	H=210
Rubber Buffer, suspension	All Models	ST	F8-5996	H=63
Rubber Buffer, suspension	1.0, 1.4, 1.4 16V, 1.4 TDI, 1.6 16V GTI, 1.9 SDI	ch.→6N-W-098090	F8-6004	H=133
Rubber Buffer, suspension	1.0, 1.4, 1.4 16V, 1.4 TDI, 1.6 16V GTI, 1.9 SDI	ch.6N-W-098091→	F8-6006	H=100
Stabiliser Mounting	All Models	Stabi. Diam. [mm]= 18	F8-6190	d=16
Stabiliser Mounting	All Models	for OE: 0AD / 0AH; Stabi. Diam. [mm]= 20, 22	F8-6191	d=18
Top Strut Mounting	1.0, 1.4, 1.4 16V, 1.4 TDI, 1.6 16V GTI, 1.7 SDI, 1.9 D, 1.9 SDI		F8-6281	
Repair Kit, suspension strut	1.0, 1.4, 1.4 16V, 1.4 TDI, 1.6 16V GTI, 1.7 SDI, 1.9 D, 1.9 SDI		F8-6382	

<b>AK-735028</b>	<b>AK-735410</b>	<b>F5-1004</b>	<b>F5-1010</b>	<b>F5-1011</b>	<b>F8-1007</b>	<b>F8-1007S</b>
Ref.Nr.:	Ref.Nr.: 1J0412303	Ref.Nr.: 038903119T	Ref.Nr.: 028903119S	Ref.Nr.: 038903119Q	Ref.Nr.: 191407181A	Ref.Nr.: 191407181A
<b>F8-5104</b>	<b>F8-5105</b>	<b>F8-5341</b>	<b>F8-5341S</b>	<b>F8-5402</b>	<b>F8-5403</b>	<b>F8-5494</b>
Ref.Nr.: 6N0407182	Ref.Nr.: 6N0407181	Ref.Nr.: 6N0501541D	Ref.Nr.: 6N0501541D	Ref.Nr.: 191512335	Ref.Nr.: 191512333	Ref.Nr.: 6N0412331
<b>F8-5523</b>	<b>F8-5537</b>	<b>F8-5540</b>	<b>F8-5683</b>	<b>F8-5996</b>	<b>F8-6004</b>	<b>F8-6006</b>
Ref.Nr.: 6N0412331A	Ref.Nr.: 6N0412331E	Ref.Nr.: 6N0199262L	Ref.Nr.: 357413175A	Ref.Nr.: 1H0412303B	Ref.Nr.: 6N0512131A	Ref.Nr.: 6K0512131A

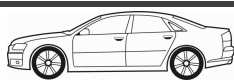
**Article Description****Article Nr.****Fitting Position****POLO (6N2) 10/1999 → 09/2001**

Belt Pulley, crankshaft	1.7 SDI, 1.9 SDI	Number of Ribs: 5	<b>F8-6398</b>		
Engine Mounting	1.0	ch.→6N-Y-200000;	<b>F8-6501</b>		
Engine Mounting	1.4		<b>F8-6501</b>		
Engine Mounting	1.4	AKK;	<b>F8-6501</b>		
Engine Mounting	1.9 D	ch.→6N-WW058709, 6N-WY065354;	<b>F8-6501</b>		
Anti-Friction Bearing	All Models		<b>F8-6569</b>		
Engine Mounting	1.0, 1.4, 1.4 16V		<b>F8-6923</b>		
Engine Mounting	1.4 16V, 1.6 16V GTI	ch.6N-Y-500001→; ch.→6N-2-010000;	<b>F8-6923</b>		
Bellow, driveshaft	1.0, 1.4, 1.4 16V, 1.4 TDi, 1.7 SDI, 1.9 D, 1.9 SDI		<b>F8-7722</b>		d1=26; d2=78; L=110
Bellow, driveshaft	1.4	AKP	<b>F8-7722</b>		d1=26; d2=78; L=110
Mounting, axle beam	1.0, 1.4, 1.4 16V, 1.4 TDi, 1.6 16V GTI, 1.7 SDI, 1.9 D, 1.9 SDI		<b>F8-7938</b>		H=80; D=72
Mounting, axle beam	1.4	AKP	<b>F8-7938</b>		H=80; D=72
Engine Mounting	1.4 16V	AFK, AUB	<b>F8-7948</b>		
Engine Mounting	1.4 16V	AHW, AUA	<b>F8-7948</b>		
Engine Mounting	1.6 16V GTI		<b>F8-7948</b>		
Belt Pulley, crankshaft	1.4 TDi	ch.6N-YD-000-001, 6N-YY-500001→; Number of Ribs: 5; Parameter: 6PK	<b>F8-8038</b>		
Engine Mounting	1.7 SDI, 1.9 D, 1.9 SDI		<b>F8-8189</b>		
Bellow, steering	All Models	with clamps	<b>LM-10063S</b>		d1=11; d2=42; L [mm]=208
Bellow, steering	All Models	with clamps;	<b>LM-10088S</b>		d1=25; d2=40; L [mm]=143

**POLO Saloon (9A4) 09/2002 →**

Dust Cover Kit, shock absorber	All Models	ST	<b>AK-735095</b>		
Dust Cover Kit, shock absorber	All Models	ST	<b>AK-735410</b>		H=210
Alternator Freewheel Clutch	1.4 TDi, 1.9 SDI, 1.9 TDi		<b>F5-1004</b>		
Top Strut Mounting	All Models		<b>F8-5380</b>		
Rubber Buffer, suspension	1.4, 1.4 TDi, 1.9 SDI		<b>F8-5381</b>		H=37; D=76
Engine Mounting	1.4		<b>F8-5532</b>		
Engine Mounting	1.4		<b>F8-5534</b>		
Engine Mounting	1.4	BBY;	<b>F8-5534</b>		
Engine Mounting	1.9 SDI		<b>F8-5535</b>		
Top Strut Mounting	All Models		<b>F8-5537</b>		
Engine Mounting	1.4		<b>F8-5551</b>		
Protective Cap/Bellow, shock absorber	All Models		<b>F8-5683</b>		H=210

<b>AK-735095</b>	<b>AK-735410</b>	<b>F5-1004</b>	<b>F8-5380</b>	<b>F8-5381</b>	<b>F8-5532</b>	<b>F8-5534</b>
Ref.Nr.: 1J0512131B	Ref.Nr.: 1J0412303	Ref.Nr.: 038903119T	Ref.Nr.: 1J0513353G	Ref.Nr.: 1J0512149B	Ref.Nr.: 6Q0199851S	Ref.Nr.: 6Q0199851AB
<b>F8-5535</b>	<b>F8-5537</b>	<b>F8-5551</b>	<b>F8-5683</b>	<b>F8-6044</b>	<b>F8-6398</b>	<b>F8-6501</b>
Ref.Nr.: 6Q0199167BQ	Ref.Nr.: 6N0412331E	Ref.Nr.: 6Q0199167BM	Ref.Nr.: 357413175A	Ref.Nr.: 3C0513425	Ref.Nr.: 028 105 243AC	Ref.Nr.: 6N0 199 851 AG
<b>F8-6569</b>	<b>F8-6923</b>	<b>F8-7722</b>	<b>F8-7938</b>	<b>F8-7948</b>	<b>F8-8038</b>	<b>F8-8189</b>
Ref.Nr.: 6N0412249C	Ref.Nr.: 6N0199555AA	Ref.Nr.: 191407285F	Ref.Nr.: 6K0501541A	Ref.Nr.: 6N0199262G	Ref.Nr.: 045105243C	Ref.Nr.: 6N0199555H

Article Description



Article Nr.

Fitting Position



**POLO Saloon (9A4)**

09/2002 →

Protective Cap/Bellow, shock absorber	All Models		<b>F8-6044</b>		H=160
Mounting, axle beam	1.4	BBY	<b>F8-6076</b>		d=12; L=90; D=69
Mounting, axle beam	1.4, 1.4 TDI, 1.6, 1.9 SDI		<b>F8-6076</b>		d=12; L=90; D=69
Repair Set, axle beam	1.4	BBY	<b>F8-6077</b>		H=90; D=69
Repair Set, axle beam	1.4, 1.4 TDI, 1.6, 1.9 SDI		<b>F8-6077</b>		H=90; D=69
Top Strut Mounting	All Models		<b>F8-6281</b>		
Stabiliser Mounting	All Models	ch.→9N-3-150000	<b>F8-6460</b>		d=18
Stabiliser Mounting	All Models	Stabi. Diam. [mm]= 19	<b>F8-6461</b>		d=17
Stabiliser Mounting	All Models	Stabi. Diam. [mm]= 18	<b>F8-6462</b>		d=16
Engine Mounting	1.4 TDI		<b>F8-6533</b>		
Anti-Friction Bearing	All Models		<b>F8-6569</b>		
Belt Pulley, crankshaft	1.9 SDI	Number of Ribs: 5; Parameter: 6PK	<b>F8-6572</b>		
Stabiliser Mounting	1.6, 1.9 SDI, 1.9 TDI	ch.→9N-3-150000	<b>F8-6694</b>		d=19.8
Rubber Buffer, suspension	1.4, 1.4 TDI, 1.6, 1.9 SDI		<b>F8-6723</b>		H=124
Control Arm-/Trailing Arm Bush	1.4, 1.4 TDI, 1.9 SDI		<b>F8-6736</b>		
Engine Mounting	1.4		<b>F8-6752</b>		
Protective Cap/Bellow, shock absorber	All Models		<b>F8-7132</b>		H=190
Protective Cap/Bellow, shock absorber	All Models	<b>SP, ST</b>	<b>F8-7338</b>		
Rubber Buffer, suspension	All Models	for OE: 1JC, 1JS; <b>SP</b>	<b>F8-7658</b>		H=114
Rubber Buffer, suspension	All Models		<b>F8-7675</b>		H=84
Rubber Buffer, suspension	All Models	<b>SP</b>	<b>F8-7676</b>		H=56
Control Arm-/Trailing Arm Bush	All Models		<b>F8-7873</b>		
Stabiliser Mounting	1.4, 1.4 TDI, 1.9 SDI, 1.9 TDI	ch.→9N-3D-170762, 9N-3Y-245376	<b>F8-7914</b>		d=20,8
Engine Mounting	1.4		<b>F8-7949</b>		
Engine Mounting	1.4	BBY;	<b>F8-7949</b>		
Engine Mounting	1.4		<b>F8-7951</b>		
Engine Mounting	1.4 TDI		<b>F8-7952</b>		
Engine Mounting	1.4	BBY;	<b>F8-7954</b>		
Engine Mounting	1.9 TDI		<b>F8-7956</b>		
Engine Mounting	1.4, 1.4 TDI, 1.6, 1.9 SDI		<b>F8-8164</b>		

<b>AK-735004</b>	<b>F8-6044</b>	<b>F8-6076</b>	<b>F8-6077</b>	<b>F8-6281</b>	<b>F8-6460</b>	<b>F8-6461</b>
Ref.Nr.:	Ref.Nr.: 3C0513425	Ref.Nr.: 1J0501541D	Ref.Nr.: 1J0501541DS	Ref.Nr.: 8Z0412331	Ref.Nr.: 6Q0411314R	Ref.Nr.: 6Q0 411 314 M
<b>F8-6462</b>	<b>F8-6533</b>	<b>F8-6569</b>	<b>F8-6572</b>	<b>F8-6694</b>	<b>F8-6723</b>	<b>F8-6736</b>
Ref.Nr.: 6Q0411314L	Ref.Nr.: 6Q0 199 167 CA	Ref.Nr.: 6N0412249C	Ref.Nr.: 038105243L	Ref.Nr.: 6Q0411314F	Ref.Nr.: 6Q0512131B	Ref.Nr.: 1K0407183A
<b>F8-6752</b>	<b>F8-7132</b>	<b>F8-7338</b>	<b>F8-7658</b>	<b>F8-7675</b>	<b>F8-7676</b>	<b>F8-7873</b>
Ref.Nr.: 6Q0199167BN	Ref.Nr.: 6N0413175A	Ref.Nr.: 6Q0513425	Ref.Nr.: 6Q0512131C	Ref.Nr.: 6Q0412301	Ref.Nr.: 6Q0412301A	Ref.Nr.: 6Q0407182A



**Article Description****Article Nr.****Fitting Position**

<b>POLO (9N_)</b>			<b>10/2001 → 11/2009</b>	
Dust Cover Kit, shock absorber	1.2, 1.2 12V, 1.4 16V, 1.4 FSI, 1.4 TDI, 1.6, 1.6 16V, 1.8 GTI, 1.8 GTI Cup Edition, 1.9 SDI, 1.9 TDI		<b>AK-735004</b>	
Dust Cover Kit, shock absorber	1.2, 1.2 12V, 1.4 16V, 1.4 FSI, 1.4 TDI, 1.6, 1.6 16V, 1.8 GTI, 1.8 GTI Cup Edition, 1.9 SDI, 1.9 TDI		<b>AK-735095</b>	
Dust Cover Kit, shock absorber	All Models	<b>ST</b>	<b>AK-735410</b>	H=210
Alternator Freewheel Clutch	1.2, 1.2 12V		<b>F5-1000</b>	
Alternator Freewheel Clutch	1.4 TDI, 1.9 SDI, 1.9 TDI		<b>F5-1004</b>	
Alternator Freewheel Clutch	1.4 TDI, 1.9 TDI		<b>F5-1085</b>	
Top Strut Mounting	1.2, 1.2 12V, 1.4, 1.4 16V, 1.4 FSI, 1.4 TDI, 1.6, 1.6 16V, 1.8 GTI, 1.8 GTI Cup Edition, 1.9 SDI, 1.9 TDI		<b>F8-5380</b>	
Rubber Buffer, suspension	1.2, 1.2 12V, 1.4 16V, 1.4 FSI, 1.4 TDI, 1.8 GTI, 1.9 SDI, 1.9 TDI		<b>F8-5381</b>	H=37; D=76
Engine Mounting	1.4 16V	ch.9N-2-000001-→;  BBY, BKY;	<b>F8-5532</b>	
Engine Mounting	1.4 16V, 1.4 FSI, 1.6 16V		<b>F8-5534</b>	
Engine Mounting	1.9 SDI, 1.9 TDI		<b>F8-5535</b>	
Top Strut Mounting	1.2, 1.2 12V, 1.4 16V, 1.4 FSI, 1.4 TDI, 1.6, 1.6 16V, 1.8 GTI, 1.8 GTI Cup Edition, 1.9 SDI, 1.9 TDI		<b>F8-5537</b>	
Engine Mounting	1.4 16V	AUA, BBY, BKY;	<b>F8-5551</b>	
Engine Mounting	1.4 16V, 1.4 FSI		<b>F8-5551</b>	
Belt Pulley, crankshaft	1.8 GTI, 1.8 GTI Cup Edition		<b>F8-5650</b>	
Protective Cap/Bellow, shock absorber	All Models		<b>F8-5683</b>	H=210
Protective Cap/Bellow, shock absorber	1.2, 1.2 12V, 1.4 16V, 1.4 FSI, 1.4 TDI, 1.6, 1.6 16V, 1.8 GTI, 1.8 GTI Cup Edition, 1.9 SDI, 1.9 TDI		<b>F8-6044</b>	H=160
Mounting, axle beam	1.2	BMD	<b>F8-6076</b>	d=12; L=90; D=69
Mounting, axle beam	1.2 12V	BME	<b>F8-6076</b>	d=12; L=90; D=69
Mounting, axle beam	1.4 16V	AUA	<b>F8-6076</b>	d=12; L=90; D=69
Mounting, axle beam	1.4 16V	BBZ	<b>F8-6076</b>	d=12; L=90; D=69
Mounting, axle beam	1.4 FSI, 1.4 TDI, 1.6, 1.8 GTI, 1.9 SDI		<b>F8-6076</b>	d=12; L=90; D=69
Mounting, axle beam	1.4 TDI	BNM	<b>F8-6076</b>	d=12; L=90; D=69
Mounting, axle beam	1.9 TDI	ASZ	<b>F8-6076</b>	d=12; L=90; D=69
Mounting, axle beam	1.9 TDI	AXR	<b>F8-6076</b>	d=12; L=90; D=69
Repair Set, axle beam	1.2	BMD	<b>F8-6077</b>	H=90; D=69
Repair Set, axle beam	1.2 12V	AZQ	<b>F8-6077</b>	H=90; D=69
Repair Set, axle beam	1.4 16V	BBY	<b>F8-6077</b>	H=90; D=69
Repair Set, axle beam	1.4 16V	BBZ	<b>F8-6077</b>	H=90; D=69
Repair Set, axle beam	1.4 FSI, 1.4 TDI, 1.6, 1.8 GTI, 1.9 SDI		<b>F8-6077</b>	H=90; D=69
Repair Set, axle beam	1.4 TDI	BNM	<b>F8-6077</b>	H=90; D=69

<b>AK-735004</b>	<b>AK-735095</b>	<b>AK-735410</b>	<b>F5-1000</b>	<b>F5-1004</b>	<b>F5-1085</b>	<b>F8-5380</b>
Ref.Nr.:	Ref.Nr.: 1J0512131B	Ref.Nr.: 1J0412303	Ref.Nr.: 03D903119A	Ref.Nr.: 038903119T	Ref.Nr.: 045903119A	Ref.Nr.: 1J0513353G
<b>F8-5381</b>	<b>F8-5532</b>	<b>F8-5534</b>	<b>F8-5535</b>	<b>F8-5537</b>	<b>F8-5551</b>	<b>F8-5650</b>
Ref.Nr.: 1J0512149B	Ref.Nr.: 6Q0199851S	Ref.Nr.: 6Q0199851AB	Ref.Nr.: 6Q0199167BQ	Ref.Nr.: 6N0412331E	Ref.Nr.: 6Q0199167BM	Ref.Nr.: 06A105243E
<b>F8-5683</b>	<b>F8-6044</b>	<b>F8-6076</b>	<b>F8-6077</b>			
Ref.Nr.: 357413175A	Ref.Nr.: 3C0513425	Ref.Nr.: 1J0501541D	Ref.Nr.: 1J0501541DS			

Article Description



Article Nr.

Fitting Position



POLO (9N_)				10/2001 → 11/2009	
Repair Set, axle beam	1.9 TDI	ASZ	<b>F8-6077</b>		H=90; D=69
Repair Set, axle beam	1.9 TDI	AXR	<b>F8-6077</b>		H=90; D=69
Top Strut Mounting	1.2, 1.2 12V, 1.4 16V, 1.4 FSI, 1.4 TDI, 1.6, 1.6 16V, 1.8 GTI, 1.8 GTi Cup Edition, 1.9 SDI, 1.9 TDI		<b>F8-6281</b>		
Belt Pulley, crankshaft	1.9 TDI	ch.9N-2-000001, 9N-3-110001→;  ASZ; Number of Ribs: 5; Parameter: 6PK	<b>F8-6396</b>		H=41.6; d=30; Mounting points diam.[mm]=7, 8.6; D=139.7
Belt Pulley, crankshaft	1.9 TDI	ch.9N-2-000001, 9N-3-110001→;  ATD; Number of Ribs: 5; Parameter: 6PK	<b>F8-6396</b>		H=41.6; d=30; Mounting points diam.[mm]=7, 8.6; D=139.7
Stabiliser Mounting	1.2, 1.2 12V, 1.4 16V, 1.4 FSI, 1.4 TDI, 1.6, 1.6 16V, 1.8 GTI, 1.8 GTi Cup Edition, 1.9 SDI, 1.9 TDI	ch.→9N-3-150000	<b>F8-6460</b>		d=18
Stabiliser Mounting	1.2, 1.2 12V, 1.4 16V, 1.4 FSI, 1.4 TDI, 1.6, 1.6 16V, 1.8 GTI, 1.8 GTi Cup Edition, 1.9 SDI, 1.9 TDI	Stabi. Diam. [mm]= 19	<b>F8-6461</b>		d=17
Stabiliser Mounting	1.2, 1.2 12V, 1.4 16V, 1.4 FSI, 1.4 TDI, 1.6, 1.6 16V, 1.8 GTI, 1.8 GTi Cup Edition, 1.9 SDI, 1.9 TDI	Stabi. Diam. [mm]= 18	<b>F8-6462</b>		d=16
Engine Mounting	1.2, 1.2 12V		<b>F8-6532</b>		
Engine Mounting	1.4 TDI		<b>F8-6533</b>		
Anti-Friction Bearing	1.2, 1.2 12V, 1.4 16V, 1.4 FSI, 1.4 TDI, 1.6, 1.6 16V, 1.8 GTI, 1.8 GTi Cup Edition, 1.9 SDI, 1.9 TDI		<b>F8-6569</b>		
Belt Pulley, crankshaft	1.9 SDI	Number of Ribs: 5; Parameter: 6PK	<b>F8-6572</b>		
Stabiliser Mounting	1.2, 1.2 12V, 1.4 16V, 1.4 FSI, 1.4 TDI, 1.6, 1.9 SDI, 1.9 TDI	ch.→9N-3-150000	<b>F8-6694</b>		d=19.8
Rubber Buffer, suspension	1.2, 1.2 12V, 1.4, 1.4 16V, 1.4 FSI, 1.4 TDI, 1.6, 1.6 16V, 1.6 Total Flex, 1.9 SDI, 1.9 TDI	for OE: 1JB, 1JL, 1JP, UA4;	<b>F8-6723</b>		H=124
Control Arm-/Trailing Arm Bush	1.2, 1.2 12V, 1.4 16V, 1.4 FSI, 1.4 TDI, 1.6 16V, 1.8 GTI, 1.9 SDI, 1.9 TDI		<b>F8-6736</b>		
Engine Mounting	1.4 16V		<b>F8-6752</b>		
Engine Mounting	1.9 TDI	ch.9N-5-500001→	<b>F8-6945</b>		
Engine Mounting	1.8 GTI	ch.9N-5-500-001→	<b>F8-6987</b>		
Protective Cap/Bellow, shock absorber	1.2, 1.2 12V, 1.4, 1.4 16V, 1.4 FSI, 1.4 TDI, 1.6, 1.6 16V, 1.8 GTI, 1.8 GTi Cup Edition, 1.9 SDI, 1.9 TDI		<b>F8-7132</b>		H=190
Protective Cap/Bellow, shock absorber	All Models		<b>F8-7338</b>		
Rubber Buffer, suspension	1.2, 1.2 12V, 1.4 16V, 1.4 FSI, 1.4 TDI, 1.6, 1.6 16V, 1.8 GTI, 1.8 GTi Cup Edition, 1.9 SDI, 1.9 TDI	for OE: 1JC, 1JS;	<b>F8-7658</b>		H=114
Rubber Buffer, suspension	1.2, 1.2 12V, 1.4 16V, 1.4 FSI, 1.4 TDI, 1.6, 1.6 16V, 1.9 SDI, 1.9 TDI		<b>F8-7675</b>		H=84
Rubber Buffer, suspension	1.2, 1.2 12V, 1.4 16V, 1.4 FSI, 1.4 TDI, 1.6, 1.6 16V, 1.9 SDI, 1.9 TDI	for OE: G29;	<b>F8-7676</b>		H=56
Rubber Buffer, suspension	1.8 GTI, 1.8 GTi Cup Edition	for OE: G30;	<b>F8-7676</b>		H=56
Control Arm-/Trailing Arm Bush	1.2, 1.2 12V, 1.4 16V, 1.4 FSI, 1.4 TDI, 1.6		<b>F8-7873</b>		



**Article Description****Article Nr.****Fitting Position****POLO (9N\_) 10/2001 → 11/2009**

Control Arm-/Trailing Arm Bush	1.2, 1.2 12V, 1.4, 1.4 16V, 1.4 TDI, 1.6 16V, 1.8 GTI, 1.8 GTI Cup Edition, 1.9 SDI, 1.9 TDI	ch.→9N-9-050000	<b>F8-7873</b>		
Stabiliser Mounting	1.2, 1.2 12V, 1.4 16V, 1.4 FSI, 1.4 TDI, 1.9 SDI, 1.9 TDI	ch.→9N-3D-170762, 9N-3Y-245376	<b>F8-7914</b>		d=20,8
Engine Mounting	1.4 16V, 1.4 FSI, 1.6 16V		<b>F8-7949</b>		
Engine Mounting	1.4 TDI		<b>F8-7950</b>		
Engine Mounting	1.2, 1.2 12V, 1.4 16V, 1.4 FSI, 1.6 16V		<b>F8-7951</b>		
Engine Mounting	1.4 TDI		<b>F8-7952</b>		
Engine Mounting	1.4 16V		<b>F8-7954</b>		
Engine Mounting	1.2, 1.2 12V		<b>F8-7955</b>		
Engine Mounting	1.8 GTI, 1.8 GTI Cup Edition, 1.9 TDI		<b>F8-7956</b>		
Belt Pulley, crankshaft	1.4 TDI	Number of Ribs: 5; Parameter: 6PK	<b>F8-8038</b>		
Engine Mounting	1.4, 1.4 16V, 1.4 TDI, 1.9 SDI		<b>F8-8164</b>		
Engine Mounting	1.4 16V, 1.6 16V		<b>F8-8173</b>		
Engine Mounting	1.9 TDI		<b>F8-8173</b>		

**POLO (6R, 6C) 06/2009 → 05/2014**

Dust Cover Kit, shock absorber	1.2, 1.2 TDI, 1.2 TSI, 1.4, 1.4 BiFuel, 1.4 GTI, 1.6 BiFuel, 1.6 TDI	<b>ST</b>	<b>AK-735410</b>		H=210
Alternator Freewheel Clutch	1.2 TDI, 1.6 TDI, 2.0 R WRC		<b>F5-1004</b>		
Alternator Freewheel Clutch	1.2 TSI, 1.4 GTI		<b>F5-1064</b>		
Anti-Friction Bearing	1.2, 1.2 TDI, 1.2 TSI, 1.4, 1.4 BiFuel, 1.4 GTI, 1.6 BiFuel, 1.6 TDI		<b>F8-3039</b>		H=14; d1=14; D=45
Top Strut Mounting	1.2, 1.2 TDI, 1.2 TSI, 1.4, 1.4 BiFuel, 1.4 GTI, 1.6 BiFuel, 1.6 TDI		<b>F8-4067</b>		H=53; d=26; D=82
Top Strut Mounting	1.2, 1.2 TDI, 1.2 TSI, 1.4, 1.4 BiFuel, 1.4 TSI, 1.6 BiFuel, 1.6 TDI	Cross; for OE: 1JR;	<b>F8-5380</b>		
Top Strut Mounting	1.2, 1.2 TDI, 1.2 TSI, 1.4, 1.4 BiFuel, 1.4 TSI, 1.6 BiFuel, 1.6 TDI	for OE: 1JA, 1JP; <b>ST</b>	<b>F8-5380</b>		
Top Strut Mounting	1.2, 1.2 TDI, 1.2 TSI, 1.4, 1.4 BiFuel, 1.4 TSI, 1.6 BiFuel, 1.6 TDI	for OE: 1JB;	<b>F8-5380</b>		
Top Strut Mounting	1.2, 1.2 TDI, 1.2 TSI, 1.4, 1.4 BiFuel, 1.4 TSI, 1.6 BiFuel, 1.6 TDI	for OE: 1JS; <b>SP</b>	<b>F8-5380</b>		
Top Strut Mounting	1.4 GTI	for OE: 1JK, UB2	<b>F8-5380</b>		
Top Strut Mounting	2.0 R WRC		<b>F8-5380</b>		
Rubber Buffer, suspension	1.2, 1.2 TDI, 1.2 TSI, 1.4, 1.4 BiFuel, 1.4 GTI, 1.4 TSI, 1.6 BiFuel, 1.6 TDI, 2.0 R WRC		<b>F8-5381</b>		H=37; D=76
Engine Mounting	1.2, 1.4, 1.6 TDI		<b>F8-5534</b>		
Protective Cap/Bellow, shock absorber	1.2, 1.2 TDI, 1.2 TSI, 1.4, 1.4 BiFuel, 1.4 GTI, 1.6 BiFuel, 1.6 TDI		<b>F8-5683</b>		H=210
Rubber Buffer, suspension	1.2, 1.2 TDI, 1.2 TSI, 1.4, 1.6 BiFuel, 1.6 TDI	<b>ST</b>	<b>F8-5996</b>		H=63

<b>AK-735410</b>	<b>F5-1004</b>	<b>F5-1064</b>	<b>F8-3039</b>	<b>F8-4067</b>	<b>F8-5380</b>	<b>F8-5381</b>
Ref.Nr.: 1J0412303	Ref.Nr.: 038903119T	Ref.Nr.: 03C903119D	Ref.Nr.: 357412249A	Ref.Nr.: 1J0412331B	Ref.Nr.: 1J0513353G	Ref.Nr.: 1J0512149B
<b>F8-5534</b>	<b>F8-5683</b>	<b>F8-5996</b>	<b>F8-6041</b>	<b>F8-7873</b>	<b>F8-7914</b>	<b>F8-7949</b>
Ref.Nr.: 6Q0199851AB	Ref.Nr.: 357413175A	Ref.Nr.: 1H0412303B	Ref.Nr.: 1J0412303	Ref.Nr.: 6Q0407182A	Ref.Nr.: 8Z0411314B	Ref.Nr.: 6Q0199851AK
<b>F8-7950</b>	<b>F8-7951</b>	<b>F8-7952</b>	<b>F8-7954</b>	<b>F8-7955</b>	<b>F8-7956</b>	<b>F8-8038</b>
Ref.Nr.: 6Q0199851AQ	Ref.Nr.: 6Q0199555AR	Ref.Nr.: 6Q0199167DH	Ref.Nr.: 6Q0199851AL	Ref.Nr.: 6Q0199851AJ	Ref.Nr.: 6Q0199851AP	Ref.Nr.: 045105243C

Article Description



Article Nr.

Fitting Position



**POLO (6R, 6C)** 06/2009 → 05/2014

Rubber Buffer, suspension	1.2, 1.2 TDI, 1.2 TSI, 1.4, 1.4 BiFuel, 1.4 TSI, 1.6 BiFuel, 1.6 TDI	for OE: G12; <b>SP</b>	<b>F8-6041</b>		H=53
Rubber Buffer, suspension	1.4 GTI	for OE: G16; <b>SP</b>	<b>F8-6041</b>		H=53
Protective Cap/Bellow, shock absorber	1.2, 1.2 TDI, 1.2 TSI, 1.4, 1.4 BiFuel, 1.4 TSI, 1.6 BiFuel, 1.6 TDI	for OE: 1JA, 1JB; <b>ST</b>	<b>F8-6044</b>		H=160
Protective Cap/Bellow, shock absorber	1.4 GTI	for OE: UB2	<b>F8-6044</b>		H=160
Top Strut Mounting	1.2, 1.2 TDI, 1.2 TSI, 1.4, 1.4 BiFuel, 1.4 GTI, 1.6 BiFuel, 1.6 TDI		<b>F8-6280</b>		H=53; d=26; D=82
Belt Pulley, crankshaft	1.2 TDI, 1.6 TDI	Number of Ribs: 5; Parameter: 6PK	<b>F8-6572</b>		
Rubber Buffer, suspension	1.2, 1.2 TDI, 1.2 TSI, 1.4, 1.4 BiFuel, 1.4 TSI, 1.6 BiFuel, 1.6 TDI	for OE: 1JA, 1JB, 1JP, 1JR; <b>ST</b>	<b>F8-6723</b>		H=124
Top Strut Mounting	1.2, 1.2 TDI, 1.2 TSI, 1.4, 1.4 BiFuel, 1.4 GTI, 1.6 BiFuel, 1.6 TDI	for OE: 1J0412319C	<b>F8-7133</b>		
Protective Cap/Bellow, shock absorber	1.2, 1.2 TDI, 1.2 TSI, 1.4, 1.4 GTI, 1.6 BiFuel, 1.6 TDI	<b>SP</b> , <b>ST</b>	<b>F8-7338</b>		
Rubber Buffer, suspension	1.2, 1.2 TDI, 1.2 TSI, 1.4, 1.4 BiFuel, 1.4 GTI, 1.6 TDI	for OE: 1JC, 1JS; <b>SP</b>	<b>F8-7658</b>		H=114
Engine Mounting	1.4	CGGB	<b>F8-7949</b>		
Engine Mounting	1.6 TDI		<b>F8-7949</b>		
Engine Mounting	1.6 TDI	CAYC	<b>F8-7949</b>		
Engine Mounting	1.2, 1.2 TSI, 1.4, 1.4 BiFuel		<b>F8-7951</b>		
Engine Mounting	1.2		<b>F8-7955</b>		
Engine Mounting	1.6 TDI		<b>F8-7957</b>		
Engine Mounting	1.0, 1.0 TSI, 1.2 TSI, 1.2 TSI 16V, 1.4, 1.6, 1.6 BiFuel		<b>F8-8164</b>		
Engine Mounting	1.2 TSI		<b>F8-8173</b>		
Engine Mounting	1.4	CGGB	<b>F8-8173</b>		
Engine Mounting	1.6	CLSA;	<b>F8-8173</b>		

**POLO Saloon** 05/2010 →

Alternator Freewheel Clutch	All Models		<b>F5-1064</b>		
Anti-Friction Bearing	All Models		<b>F8-3039</b>		H=14; d1=14; D=45
Top Strut Mounting	All Models		<b>F8-4067</b>		H=53; d=26; D=82
Top Strut Mounting	All Models		<b>F8-5380</b>		
Rubber Buffer, suspension	All Models		<b>F8-5381</b>		H=37; D=76
Rubber Buffer, suspension	1.6	for OE: G12; <b>SP</b>	<b>F8-6041</b>		H=53
Protective Cap/Bellow, shock absorber	All Models	for OE: 1JA, 1JB; <b>ST</b>	<b>F8-6044</b>		H=160
Top Strut Mounting	All Models		<b>F8-6280</b>		H=53; d=26; D=82
Rubber Buffer, suspension	All Models	for OE: 1JA, 1JB, 1JP, 1JR; <b>ST</b>	<b>F8-6723</b>		H=124

<b>F5-1064</b>	<b>F8-3039</b>	<b>F8-4067</b>	<b>F8-5380</b>	<b>F8-5381</b>	<b>F8-6041</b>	<b>F8-6044</b>
Ref.Nr.: 03C903119D	Ref.Nr.: 357412249A	Ref.Nr.: 1J0412331B	Ref.Nr.: 1J0513353G	Ref.Nr.: 1J0512149B	Ref.Nr.: 1J0412303	Ref.Nr.: 3C0513425
<b>F8-6280</b>	<b>F8-6572</b>	<b>F8-6723</b>	<b>F8-7133</b>	<b>F8-7338</b>	<b>F8-7658</b>	<b>F8-7949</b>
Ref.Nr.: 6R0412249	Ref.Nr.: 038105243L	Ref.Nr.: 6Q0512131B	Ref.Nr.: 1J0412319C	Ref.Nr.: 6Q0513425	Ref.Nr.: 6Q0512131C	Ref.Nr.: 6Q0199851AK
<b>F8-7951</b>	<b>F8-7955</b>	<b>F8-7957</b>	<b>F8-8164</b>	<b>F8-8173</b>		
Ref.Nr.: 6Q0199555AR	Ref.Nr.: 6Q0199851AJ	Ref.Nr.: 6R0199555	Ref.Nr.: 6Q0199555AS	Ref.Nr.: 6Q0199555AT		

**Article Description****Article Nr.****Fitting Position**

<b>POLO Saloon</b>			<b>05/2010 →</b>		
Top Strut Mounting	All Models	for OE: 1J0412319C	<b>F8-7133</b>		
Engine Mounting	All Models		<b>F8-8164</b>		
<b>SANTANA (32B)</b>			<b>08/1981 → 12/1985</b>		
Dust Cover Kit, shock absorber	1.3, 1.6, 1.6 D, 1.6 TD, 1.8, 1.9, 2.0		<b>AK-732516</b>		
Dust Cover Kit, shock absorber	1.3, 1.6, 1.6 D, 1.6 TD, 1.8, 1.9, 2.0		<b>AK-733023</b>		
Mounting, axle beam	1.3, 1.6, 1.6 D, 1.6 TD, 1.8, 1.9, 2.0		<b>F8-1014</b>		H1=32; H2=40; d=12; D1=44; D2=70
Engine Mounting	2.0	ch.32F332884→	<b>F8-1020</b>		H=97; D=114; T [mm]=145
Engine Mounting	2.0	ch.32H175001→;	<b>F8-1020</b>		H=97; D=114; T [mm]=145
Control Arm-Trailing Arm Bush	1.3, 1.6, 1.6 D, 1.6 TD, 1.8, 1.9, 2.0		<b>F8-1026</b>		H=44; d=10; D1=38; D2=48
Top Strut Mounting	1.3, 1.6, 1.6 D, 1.6 TD, 1.8, 1.9, 2.0		<b>F8-1027</b>		H=37; d1=14; d2=20; D=76
Stabiliser Mounting	1.3, 1.6, 1.6 D, 1.6 TD, 1.8, 1.9, 2.0		<b>F8-1029</b>		H=42; Thick. [mm]=25; W=38
Engine Mounting	1.6 D, 1.6 TD		<b>F8-3000</b>		H=60; Thick. [mm]=66; W=89
Engine Mounting	1.6, 1.8		<b>F8-3000</b>		H=60; Thick. [mm]=66; W=89
Anti-Friction Bearing	1.3, 1.6, 1.6 D, 1.6 TD, 1.8, 1.9, 2.0, 2.1		<b>F8-3036</b>		
Flange, carburettor	1.6, 1.8		<b>F8-3044</b>		H=21
Flange, carburettor	All Models		<b>F8-3045</b>		H=21
Mounting, radiator	1.9, 2.0, 2.1		<b>F8-4009</b>		H1=15; H2=37; D=39; Outer Thread [mm]=M8 x 1,50
Mounting, manual transmission	1.3, 1.6, 1.6 D, 1.6 TD, 1.8		<b>F8-4030</b>		H=50; d=14; D=84
Control Arm-Trailing Arm Bush	1.3, 1.6, 1.6 D, 1.6 TD, 1.8, 1.9, 2.0		<b>F8-4043</b>		H=44; d=10; D1=37; D2=54
Rubber Buffer, suspension	1.3, 1.6, 1.6 D, 1.6 TD, 1.8, 1.9, 2.0		<b>F8-4062</b>		H=67; d1=20; d2=24; D=52
Protective Cap/Bellow, shock absorber	1.3, 1.6, 1.6 D, 1.6 TD, 1.8, 1.9, 2.0		<b>F8-4065</b>		H=97; d1=46; d2=76
Bellow, steering	1.3, 1.6, 1.6 D, 1.6 TD, 1.8, 1.9, 2.0		<b>F8-4073</b>		H=147; D=48
Stabiliser Mounting	1.3, 1.6, 1.6 D, 1.6 TD, 1.8, 1.9, 2.0, 2.1		<b>F8-5225</b>		d=19
Rubber Buffer, suspension	All Models		<b>F8-5673</b>		Thick. [mm]=160
Engine Mounting	1.6, 1.6 D, 1.9, 2.0, 2.1		<b>F8-5685</b>		H=36; d=10; D=40.5
Engine Mounting	1.6, 1.6 D, 1.6 TD, 1.8		<b>F8-6834</b>		
Bellow, driveshaft	1.3, 1.3 CX, 1.6, 1.6 D, 1.6 TD, 1.8	ch.→31-L-400000	<b>F8-7722</b>		d1=26; d2=78; L=110
Bellow, driveshaft	1.9, 2.0, 2.1	ch.→32-D-099297	<b>F8-7722</b>		d1=26; d2=78; L=110
Bellow, steering	1.3, 1.6, 1.6 D, 1.6 TD, 1.8, 1.9, 2.0, 2.1	with clamps	<b>LM-10026S</b>		d1=27; d2=45; L [mm]=150
Bellow, driveshaft	1.3, 1.6, 1.6 D, 1.6 TD, 1.8, 1.9, 2.0, 2.1		<b>M-830220</b>		
Bellow Set, drive shaft	1.3, 1.3 CX, 1.6, 1.6 TD, 1.8	ch.→31-L-400000	<b>MK-830220</b>		
Bellow Set, drive shaft	1.6, 1.6 D		<b>MK-830220</b>		



Article Description



Article Nr.

Fitting Position



**SANTANA (32B)**

08/1981 → 12/1985

Bellow Set, drive shaft	1.9, 2.1	ch.→32-D-099297	MK-830220		
Bellow Set, drive shaft	2.0	ch.→32-D-099297;  JS	MK-830220		

**SANTANA Variant**

04/1985 → 02/1988

Flange, carburettor	1.8		F8-3045		H=21
Rubber Buffer, suspension	1.8		F8-5673		Thick. [mm]=160
Bellow, driveshaft	1.8	ch.→31-L-400000	F8-7722		d1=26; d2=78; L=110

**SANTANA**

01/1995 →

Bellow, steering	1.8, 1.8 i		F8-4073		H=147; D=48
------------------	------------	--	---------	--	-------------

**SCIROCCO (53)**

02/1974 → 07/1980

Dust Cover Kit, shock absorber	1.1, 1.3, 1.5, 1.6		AK-733023		
Dust Cover Kit, shock absorber	1.1, 1.3, 1.5, 1.6		AK-735006		
Engine Mounting	1.5, 1.6		F8-1001		H1=42; H2=61; d=11; D=74.5
Engine Mounting	1.6	Engine028657→	F8-1001		H1=42; H2=61; d=11; D=74.5
Top Strut Mounting	1.1, 1.6	ch.5372078001→; 01/1977 →; with slide bearing	F8-1002		
Top Strut Mounting	1.3, 1.5	ch.5372078001→; with slide bearing	F8-1002		
Top Strut Mounting	1.5	with slide bearing	F8-1002		
Anti-Friction Bearing	1.1, 1.3, 1.5, 1.6		F8-3036		
Flange, carburettor	1.6	01/1977 →; Engine028658→	F8-3046		H=23
Flange, carburettor	1.3		F8-4013		H1=84; H2=95; d=36; T [mm]=68
Rubber Buffer, silencer	1.3, 1.5, 1.6		F8-4026		H=12; W=57, 60
Clamp, silencer	1.1, 1.3, 1.5, 1.6		F8-4027		H=17; W=53, 61
Protective Cap/Bellow, shock absorber	1.1, 1.6	ch.5372078001→; 01/1977 →	F8-4064		H=90; d1=50; d2=71; D1=66; D2=77
Protective Cap/Bellow, shock absorber	1.3, 1.5	ch.5372078001→	F8-4064		H=90; d1=50; d2=71; D1=66; D2=77
Bellow Set, steering	1.1, 1.3, 1.5, 1.6	for OE: 171419832A	F8-4074		H=125; D1=34; D2=39
Stabiliser Mounting	1.5, 1.6		F8-5146		D=15
Stabiliser Mounting	1.6	01/1976 →	F8-5146		D=15
Stabiliser Mounting	1.5, 1.6		F8-5147		D=15
Stabiliser Mounting	1.6	01/1976 →	F8-5147		D=15
Rubber Buffer, suspension	1.1, 1.3, 1.5, 1.6		F8-5755		
Bellow, driveshaft	1.1, 1.3, 1.5, 1.6	ch.53-A-051001→	F8-7722		d1=26; d2=78; L=110
Bellow, driveshaft	1.6	ch.53-A-051001→;  FN	F8-7722		d1=26; d2=78; L=110
Control Arm-/Trailing Arm Bush	1.1, 1.3, 1.5, 1.6		G9-540		H=55; d=16; D=38

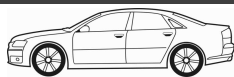

**Article Description****Article Nr.****Fitting Position**

<b>SCIROCCO (53)</b>				<b>02/1974 → 07/1980</b>	
Control Arm-/Trailing Arm Bush	1.1, 1.3, 1.5, 1.6		<b>G9-541</b>		H=62; d=12; D=34
Control Arm-/Trailing Arm Bush	1.1, 1.3, 1.5, 1.6		<b>G9-648</b>		H=54; d=12; D1=33; D2=36
Bellow, steering	1.1, 1.3, 1.5, 1.6	with clamps;	<b>LM-10003S</b>		d1=10; d2=43; L [mm]=210
Bellow, steering	1.1, 1.3, 1.5, 1.6	with clamps	<b>LM-10006S</b>		d1=10; d2=41; L [mm]=210
Bellow, steering	All Models	with clamps;	<b>LM-10024S</b>		d1=25; d2=41; L [mm]=120
Bellow, steering	All Models	with clamps;	<b>LM-10050S</b>		d1=25; d2=39; L [mm]=126
Bellow, steering	1.1, 1.3, 1.5, 1.6	with clamps	<b>LM-10064S</b>		d1=25; d2=35; L [mm]=144
Bellow, driveshaft	1.1, 1.3, 1.5, 1.6		<b>M-830220</b>		
Bellow Set, drive shaft	1.1, 1.3, 1.5, 1.6	ch.53-A-051001→	<b>MK-830220</b>		
Bellow Set, drive shaft	1.6	ch.53-A-051001→; 01/1980 →	<b>MK-830220</b>		
Bellow Set, drive shaft	1.6	ch.53-A-051001→;  FN	<b>MK-830220</b>		
<b>SCIROCCO (53B)</b>				<b>08/1980 → 07/1992</b>	
Dust Cover Kit, shock absorber	1.3, 1.5, 1.6, 1.8, 1.8 16V		<b>AK-733023</b>		
Dust Cover Kit, shock absorber	1.3, 1.5, 1.6, 1.8, 1.8 16V		<b>AK-735006</b>		
Engine Mounting	1.5, 1.6		<b>F8-1001</b>		H1=42; H2=61; d=11; D=74.5
Engine Mounting	1.6	Engine028657→	<b>F8-1001</b>		H1=42; H2=61; d=11; D=74.5
Engine Mounting	1.6, 1.8	ch.→53-J-045000	<b>F8-1001</b>		H1=42; H2=61; d=11; D=74.5
Top Strut Mounting	1.3, 1.5, 1.6, 1.8, 1.8 16V	with slide bearing	<b>F8-1002</b>		
Anti-Friction Bearing	1.3, 1.5, 1.6, 1.8, 1.8 16V		<b>F8-3036</b>		
Flange, carburettor	1.6		<b>F8-3044</b>		H=21
Flange, carburettor	1.6, 1.8	01/1984 →	<b>F8-3044</b>		H=21
Flange, carburettor	1.6		<b>F8-3046</b>		H=23
Flange, carburettor	1.3		<b>F8-4013</b>		H1=84; H2=95; d=36; T [mm]=68
Rubber Buffer, silencer	1.3, 1.5, 1.6, 1.8		<b>F8-4026</b>		H=12; W=57, 60
Clamp, silencer	1.3, 1.5, 1.6, 1.8, 1.8 16V		<b>F8-4027</b>		H=17; W=53, 61
Protective Cap/Bellow, shock absorber	1.3, 1.5, 1.6, 1.8, 1.8 16V		<b>F8-4064</b>		H=90; d1=50; d2=71; D1=66; D2=77
Bellow Set, steering	1.3, 1.5, 1.6, 1.8, 1.8 16V	for OE: 171419832A	<b>F8-4074</b>		H=125; D1=34; D2=39
Bellow, steering	1.3, 1.5, 1.6, 1.8, 1.8 16V		<b>F8-4075</b>		H=200; d=10; D=48
Stabiliser Mounting	1.5, 1.6, 1.8, 1.8 16V		<b>F8-5146</b>		D=15
Stabiliser Mounting	1.5, 1.6, 1.8, 1.8 16V		<b>F8-5147</b>		D=15
Rubber Buffer, suspension	1.3, 1.5, 1.6, 1.8, 1.8 16V		<b>F8-5755</b>		
Bellow, driveshaft	1.3, 1.5, 1.6	ch.53-A-051001→	<b>F8-7722</b>		d1=26; d2=78; L=110
Bellow, driveshaft	1.8	ch.→53-E-012217	<b>F8-7722</b>		d1=26; d2=78; L=110



Article Description



Article Nr.

Fitting Position



<b>SCIROCCO (53B)</b>				<b>08/1980 → 07/1992</b>	
Bellow, driveshaft	1.8	ch.→53-E-012217;  DX	<b>F8-7722</b>	⊕ ⊕	d1=26; d2=78; L=110
Bellow, driveshaft	1.8	ch.→53-J-001854;	<b>F8-7722</b>	⊕ ⊕	d1=26; d2=78; L=110
Bellow, driveshaft	1.8	ch.→53-K-020000;	<b>F8-7722</b>	⊕ ⊕	d1=26; d2=78; L=110
Bellow, driveshaft	1.8	ch.53-A-051001→;  JJ	<b>F8-7722</b>	⊕ ⊕	d1=26; d2=78; L=110
Control Arm-/Trailing Arm Bush	1.3, 1.5, 1.6, 1.8, 1.8 16V		<b>G9-540</b>	⊕ ⊕	H=55; d=16; D=38
Control Arm-/Trailing Arm Bush	1.3, 1.5, 1.6, 1.8, 1.8 16V		<b>G9-541</b>	⊕ ⊕	H=62; d=12; D=34
Control Arm-/Trailing Arm Bush	1.3, 1.5, 1.6, 1.8, 1.8 16V		<b>G9-648</b>	⊕ ⊕ ↓	H=54; d=12; D1=33; D2=36
Bellow, steering	1.3, 1.5, 1.6, 1.8, 1.8 16V	with clamps;	<b>LM-10003S</b>		d1=9; d2=43; L [mm]=210
Bellow, steering	1.3, 1.5, 1.6, 1.8, 1.8 16V	with clamps	<b>LM-10006S</b>		d1=10; d2=41; L [mm]=210
Bellow, steering	1.3, 1.5, 1.6, 1.8, 1.8 16V	with clamps;	<b>LM-10024S</b>	⊕	d1=25; d2=41; L [mm]=120
Bellow, steering	1.3, 1.5, 1.6, 1.8, 1.8 16V	with clamps;	<b>LM-10024S</b>		d1=25; d2=41; L [mm]=120
Bellow, steering	1.3, 1.5, 1.6, 1.8, 1.8 16V	with clamps;	<b>LM-10050S</b>	⊕	d1=25; d2=39; L [mm]=126
Bellow, steering	1.3, 1.5, 1.6, 1.8, 1.8 16V	with clamps;	<b>LM-10050S</b>		d1=25; d2=39; L [mm]=126
Bellow, steering	1.3, 1.5, 1.6, 1.8, 1.8 16V	with clamps	<b>LM-10064S</b>		d1=25; d2=35; L [mm]=144
Bellow, steering	1.8	DX, JJ; with clamps	<b>LM-10064S</b>		d1=25; d2=35; L [mm]=144
Bellow, driveshaft	1.3, 1.5, 1.6, 1.8		<b>M-830220</b>	⊕ ⊕	
Bellow Set, drive shaft	1.3, 1.5, 1.6	ch.53-A-051001→	<b>MK-830220</b>		
Bellow Set, drive shaft	1.6		<b>MK-830220</b>		
Bellow Set, drive shaft	1.8	ch.→53-E-012217	<b>MK-830220</b>		
Bellow Set, drive shaft	1.8	ch.→53-K-020000;	<b>MK-830220</b>		
Bellow Set, drive shaft	1.8	DX, JJ	<b>MK-830220</b>		
<b>SCIROCCO (137, 138)</b>				<b>05/2008 → 11/2009</b>	
Dust Cover Kit, shock absorber	1.4 TSI, 2.0 TDI, 2.0 TSI	<b>ST</b>	<b>AK-735095</b>	⊕ ⊕	
Alternator Freewheel Clutch	2.0 R, 2.0 TDI		<b>F5-1004</b>		
Alternator Freewheel Clutch	2.0 TSI		<b>F5-1044</b>		
Alternator Freewheel Clutch	1.4 TSI		<b>F5-1064</b>		
Control Arm-/Trailing Arm Bush	1.4 TSI, 2.0 R, 2.0 TDI, 2.0 TSI		<b>F8-5633</b>	⊕ ⊕	
Protective Cap/Bellow, shock absorber	1.4 TSI, 2.0 R, 2.0 TDI, 2.0 TSI		<b>F8-6044</b>	⊕ ⊕	H=160
Top Strut Mounting	1.4 TSI, 2.0 R, 2.0 TDI, 2.0 TSI		<b>F8-6284</b>		
Top Strut Mounting	1.4 TSI, 2.0 R, 2.0 TDI, 2.0 TSI	<b>ST</b>	<b>F8-6348</b>		
Top Strut Mounting	1.4 TSI, 2.0 R, 2.0 TDI, 2.0 TSI	<b>SP</b>	<b>F8-6348</b>		

<b>AK-735095</b>	<b>F5-1004</b>	<b>F5-1044</b>	<b>F5-1064</b>	<b>F8-5633</b>	<b>F8-6044</b>	<b>F8-6284</b>
Ref.Nr.: 1J0512131B	Ref.Nr.: 038903119T	Ref.Nr.: 06B903119B	Ref.Nr.: 03C903119D	Ref.Nr.: 1K0407182A	Ref.Nr.: 3C0513425	Ref.Nr.: 6N0412249C
<b>F8-6348</b>	<b>F8-6424</b>	<b>F8-7722</b>	<b>G9-540</b>	<b>G9-541</b>	<b>G9-648</b>	<b>LM-10003S</b>
Ref.Nr.: 1K0513353G	Ref.Nr.: 1K0199232G	Ref.Nr.: 191407285F	Ref.Nr.: 171407181A	Ref.Nr.: 171407182D	Ref.Nr.: 357407182	Ref.Nr.: 357422831A
<b>LM-10006S</b>	<b>LM-10024S</b>	<b>LM-10050S</b>	<b>LM-10064S</b>	<b>M-830220</b>	<b>MK-830220</b>	
Ref.Nr.: 1H0422831B	Ref.Nr.: 171419831B	Ref.Nr.: 171419831C	Ref.Nr.: 171419832C	Ref.Nr.: 191498203C	Ref.Nr.: 171498203	



**Article Description****Article Nr.****Fitting Position****SCIROCCO (137, 138)****05/2008 → 11/2009**

Control Arm-/Trailing Arm Bush	1.4 TSI, 2.0 R, 2.0 TDI, 2.0 TSI	Aluminium	<b>F8-6424</b>		
Control Arm-/Trailing Arm Bush	1.4 TSI, 2.0 R, 2.0 TDI, 2.0 TSI	Aluminium	<b>F8-6425</b>		
Control Arm-/Trailing Arm Bush	1.4 TSI, 2.0 TDI, 2.0 TSI		<b>F8-6463</b>		H=64; d=12; D=60
Anti-Friction Bearing	1.4 TSI, 2.0 R, 2.0 TDI, 2.0 TSI		<b>F8-6569</b>		
Top Strut Mounting	1.4 TSI, 2.0 R, 2.0 TDI, 2.0 TSI		<b>F8-6570</b>		
Belt Pulley, crankshaft	2.0 TDI	Number of Ribs: 5; Parameter: 6PK	<b>F8-6572</b>		
Belt Pulley, crankshaft	2.0 TDI	CFGB; Number of Ribs: 5; Parameter: 6PK	<b>F8-6572</b>		
Belt Pulley, crankshaft	2.0 TDI	CFHC; Number of Ribs: 5; Parameter: 6PK	<b>F8-6572</b>		
Engine Mounting	2.0 R, 2.0 TSI		<b>F8-6989</b>		
Rubber Buffer, suspension	1.4 TSI	CAVD; for OE: G11, G45;	<b>F8-7131</b>		H=70
Rubber Buffer, suspension	1.4 TSI	CTHD; for OE: G11, G45;	<b>F8-7131</b>		H=70
Rubber Buffer, suspension	1.4 TSI, 2.0 R, 2.0 TDI, 2.0 TSI	for OE: G11, G45;	<b>F8-7131</b>		H=70
Protective Cap/Bellow, shock absorber	1.4 TSI, 2.0 R, 2.0 TDI, 2.0 TSI		<b>F8-7132</b>		H=190
Rubber Buffer, suspension	1.4 TSI, 2.0 R, 2.0 TDI, 2.0 TSI	for OE: 1JA, 1JH;	<b>F8-7576</b>		H=133
Rubber Buffer, suspension	1.4 TSI, 2.0 TDI, 2.0 TSI	for OE: 1JC, 1JE; Shape Round;	<b>F8-7601</b>		H=118
Rubber Buffer, suspension	2.0 R	Shape Round	<b>F8-7601</b>		H=118
Top Strut Mounting	1.4 TSI, 2.0 R, 2.0 TDI, 2.0 TSI		<b>F8-7603</b>		
Protective Cap/Bellow, shock absorber	1.4 TSI, 2.0 R, 2.0 TDI, 2.0 TSI		<b>F8-7640</b>		H=176
Rubber Buffer, suspension	1.4 TSI, 2.0 R, 2.0 TDI, 2.0 TSI	for OE: G07, G08;	<b>F8-7697</b>		H=55
Rubber Buffer, suspension	1.4 TSI, 2.0 R, 2.0 TDI, 2.0 TSI		<b>F8-7809</b>		H=55
Belt Pulley, crankshaft	2.0 TSI	Number of Ribs: 5; Parameter: 6PK	<b>F8-7880</b>		D=143
Control Arm-/Trailing Arm Bush	1.4 TSI, 2.0 R, 2.0 TDI, 2.0 TSI		<b>F8-7902</b>		H=60; d=12; D=42
Control Arm-/Trailing Arm Bush	1.4 TSI, 2.0 R, 2.0 TDI, 2.0 TSI		<b>F8-7907</b>		H=45; d=14; D=38
Control Arm-/Trailing Arm Bush	1.4 TSI, 2.0 R, 2.0 TDI, 2.0 TSI		<b>F8-7908</b>		H=45; d=12; D=38
Control Arm-/Trailing Arm Bush	1.4 TSI, 2.0 R, 2.0 TDI, 2.0 TSI		<b>F8-7909</b>		
Stabiliser Mounting	1.4 TSI, 2.0 R, 2.0 TDI, 2.0 TSI		<b>F8-7923</b>		d=20,7
Engine Mounting	1.4 TSI		<b>F8-7959</b>		
Engine Mounting	1.4 TSI	CAXA	<b>F8-7960</b>		
Engine Mounting	2.0 TDI, 2.0 TSI		<b>F8-7966</b>		

<b>F8-6424</b>	<b>F8-6425</b>	<b>F8-6463</b>	<b>F8-6569</b>	<b>F8-6570</b>	<b>F8-6572</b>	<b>F8-6989</b>
Ref.Nr.: 1K0199232G	Ref.Nr.: 1K0199231J	Ref.Nr.: 1K0505541B	Ref.Nr.: 6N0412249C	Ref.Nr.: 1K0412331C	Ref.Nr.: 038105243L	Ref.Nr.: 1K0199262AM
<b>F8-7131</b>	<b>F8-7132</b>	<b>F8-7576</b>	<b>F8-7601</b>	<b>F8-7603</b>	<b>F8-7640</b>	<b>F8-7697</b>
Ref.Nr.: 1K0412303B	Ref.Nr.: 6N0413175A	Ref.Nr.: 1K0 511 353 M	Ref.Nr.: 1K0511353N	Ref.Nr.: 3C0513353	Ref.Nr.: 1K0513425A	Ref.Nr.: 1K0412303F
<b>F8-7809</b>	<b>F8-7880</b>	<b>F8-7902</b>	<b>F8-7907</b>	<b>F8-7908</b>	<b>F8-7909</b>	<b>F8-7923</b>
Ref.Nr.: 1K0412303E	Ref.Nr.: 06H105243F	Ref.Nr.: 1K0505171C	Ref.Nr.: 1K0505203A	Ref.Nr.: 1K0505279A	Ref.Nr.: 1K0505553 A	Ref.Nr.: 1K0511327AR

Article Description



Article Nr.

Fitting Position



### SCIROCCO (137, 138)

05/2008 → 11/2009

Engine Mounting	1.4 TSI, 2.0 R, 2.0 TDI, 2.0 TSI		F8-7982	↑	
Engine Mounting	2.0 TDI	6-speed	F8-8152	↺	
<b>SHARAN (7M8, 7M9, 7M6)</b>					
09/1995 → 03/2010					
Dust Cover Kit, shock absorber	1.8 T 20V, 1.9 TDI, 1.9 TDI 4motion, 2.0, 2.0 TDI, 2.8 V6 24V, 2.8 V6 24V 4motion, 2.8 VR6, 2.8 VR6 Syncro		AK-735034	↻ ↻ ↻	
Alternator Freewheel Clutch	1.9 TDI, 1.9 TDI 4motion, 2.0, 2.0 LPG, 2.0 TDI, 2.8 V6 24V, 2.8 V6 24V 4motion		F5-1004		
Alternator Freewheel Clutch	1.9 TDI, 2.0		F5-1007		
Top Strut Mounting	1.8 T 20V, 1.9 TDI, 1.9 TDI 4motion, 2.0, 2.0 TDI, 2.8 V6 24V, 2.8 V6 24V 4motion, 2.8 VR6, 2.8 VR6 Syncro		F8-1034	↻ ↻ ↻	H=50; d=27; D=98
Top Strut Mounting	1.8 T 20V, 1.9 TDI, 1.9 TDI 4motion, 2.0, 2.0 TDI, 2.8 V6 24V, 2.8 V6 24V 4motion, 2.8 VR6, 2.8 VR6 Syncro		F8-1034S	↻ ↻ ↻	H=51; d=14; D=96
Anti-Friction Bearing	1.8 T 20V, 1.9 TDI, 1.9 TDI 4motion, 2.0, 2.0 LPG, 2.0 TDI, 2.8 V6 24V, 2.8 V6 24V 4motion, 2.8 VR6, 2.8 VR6 Syncro		F8-3039	↻ ↻ ↻	H=14; d1=14; D=45
Bellow, steering	1.8 T 20V, 1.9 TDI, 2.0, 2.8 V6 24V, 2.8 V6 24V 4motion, 2.8 VR6, 2.8 VR6 Syncro		F8-5051	↻ ↻ ↻	H=180; d1=10; d2=49
Stabiliser Mounting	1.8 T 20V, 1.9 TDI, 1.9 TDI 4motion, 2.0, 2.8 V6 24V, 2.8 V6 24V 4motion, 2.8 VR6, 2.8 VR6 Syncro		F8-5407	↻ ↻ ↻	d=17
Mounting, axle beam	1.8 T 20V, 1.9 TDI, 2.0, 2.8 V6 24V, 2.8 VR6, 2.8 VR6 Syncro		F8-5530	↻	
Belt Pulley, crankshaft	1.9 TDI	Number of Ribs: 5; Parameter: 6PK	F8-5649		H=31.5; d=30.02; Mounting points diam.[mm]=8.5; D1=161.5; D2=160.5
Belt Pulley, crankshaft	1.8 T 20V, 2.0		F8-5650		
Rubber Buffer, suspension	1.8 T 20V, 1.9 TDI, 2.0, 2.8 VR6, 2.8 VR6 Syncro	ch.→7M-T-007 651	F8-5993	↻ ↻ ↻	H=83
Rubber Buffer, suspension	1.8 T 20V, 1.9 TDI, 2.0, 2.8 VR6, 2.8 VR6 Syncro	ch.7M-T-007562→	F8-5995	↻ ↻ ↻	H=83
Rubber Buffer, suspension	1.9 TDI, 1.9 TDI 4motion, 2.0 TDI, 2.8 V6 24V, 2.8 V6 24V 4motion		F8-5995	↻ ↻ ↻	H=83
Belt Pulley, crankshaft	1.9 TDI, 1.9 TDI 4motion	ch.→7M-4-015000; Number of Ribs: 5; Parameter: 6PK	F8-6392		H=47; d=30; D=143
Belt Pulley, crankshaft	1.9 TDI	ch.7M-4-015001→; ANU; Number of Ribs: 5; Parameter: 6PK	F8-6396		H=41.6; d=30; Mounting points diam.[mm]=7, 8.6; D=139.7
Belt Pulley, crankshaft	1.9 TDI, 1.9 TDI 4motion	ch.7M-4-015001→; Number of Ribs: 5; Parameter: 6PK	F8-6396		H=41.6; d=30; Mounting points diam.[mm]=7, 8.6; D=139.7
Belt Pulley, crankshaft	1.9 TDI, 2.0 TDI	Number of Ribs: 5; Parameter: 6PK	F8-6396		H=41.6; d=30; Mounting points diam.[mm]=7, 8.6; D=139.7
Stabiliser Mounting	1.8 T 20V, 1.9 TDI, 1.9 TDI 4motion, 2.0, 2.0 TDI, 2.8 V6 24V, 2.8 V6 24V 4motion, 2.8 VR6, 2.8 VR6 Syncro		F8-6702	↻ ↻ ↻	d=20.6
Stabiliser Mounting	1.8 T 20V, 1.9 TDI, 2.0, 2.8 VR6, 2.8 VR6 Syncro		F8-6703	↻ ↻ ↻	H=29; d=21
Engine Mounting	1.9 TDI	AHU; △; ↻	F8-7010	↻	
Engine Mounting	2.0	ADY; △; ↻	F8-7010	↻	

<b>AK-735034</b>	<b>F5-1004</b>	<b>F5-1007</b>	<b>F8-1034</b>	<b>F8-1034S</b>	<b>F8-3039</b>	<b>F8-5051</b>
Ref.Nr.:	Ref.Nr.: 038903119T	Ref.Nr.: 028903119AQ	Ref.Nr.: 357412331A	Ref.Nr.: 7201848S1	Ref.Nr.: 357412249A	Ref.Nr.: 7398680
<b>F8-5407</b>	<b>F8-5530</b>	<b>F8-5649</b>	<b>F8-5650</b>	<b>F8-5993</b>	<b>F8-5995</b>	<b>F8-6392</b>
Ref.Nr.: 7200957	Ref.Nr.: 95VW5K818BC	Ref.Nr.: 028105243T	Ref.Nr.: 06A105243E	Ref.Nr.: 357412303F	Ref.Nr.: 1011898	Ref.Nr.: 038105243
<b>F8-6396</b>	<b>F8-6702</b>	<b>F8-6703</b>	<b>F8-7010</b>	<b>F8-7982</b>	<b>F8-8152</b>	
Ref.Nr.: 03G105243	Ref.Nr.: 7M0511413A	Ref.Nr.: 7M0511414B	Ref.Nr.: 1056804	Ref.Nr.: 1K0199868Q	Ref.Nr.: 1K0199555T	

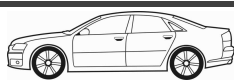
**Article Description****Article Nr.****Fitting Position****SHARAN (7M8, 7M9, 7M6)** 09/1995 → 03/2010

Engine Mounting	2.8 VR6, 2.8 VR6 Syncro		<b>F8-7010</b>		
Engine Mounting	2.8 V6 24V, 2.8 V6 24V 4motion		<b>F8-7032</b>		
Mounting, manual transmission	2.0	04/2000 →;	<b>F8-7049</b>		
Protective Cap/Bellow, shock absorber	2.8 V6 24V 4motion		<b>F8-7132</b>		H=190
Protective Cap/Bellow, shock absorber	1.8 T 20V, 1.9 TDI, 1.9 TDI 4motion, 2.0, 2.0 LPG, 2.0 TDI, 2.8 V6 24V, 2.8 V6 24V 4motion, 2.8 VR6, 2.8 VR6 Syncro		<b>F8-7688</b>		H=220
Engine Mounting	1.9 TDI		<b>F8-8150</b>		
Engine Mounting	1.9 TDI		<b>F8-8150</b>		
Control Arm-/Trailing Arm Bush	1.8 T 20V, 1.9 TDI, 1.9 TDI 4motion, 2.0, 2.8 V6 24V, 2.8 V6 24V 4motion, 2.8 VR6, 2.8 VR6 Syncro		<b>G9-664</b>		H=50; d=18; D=60
Control Arm-/Trailing Arm Bush	1.8 T 20V, 1.9 TDI, 1.9 TDI 4motion, 2.0, 2.8 V6 24V, 2.8 V6 24V 4motion, 2.8 VR6, 2.8 VR6 Syncro		<b>G9-665</b>		H=60; d=14; D1=35; D2=38
Bellow, steering	All Models	with clamps;	<b>LM-10023S</b>		d1=10; d2=49; L [mm]=180
Bellow Set, drive shaft	1.8 T 20V	AWC; with clamps;	<b>MK-810160</b>		L=116
Bellow Set, drive shaft	1.9 TDI, 1.9 TDI 4motion	ch. → 7M-3-055000; with clamps	<b>MK-810160</b>		L=116
Bellow Set, drive shaft	1.9 TDI, 2.8 V6 24V, 2.8 V6 24V 4motion	with clamps	<b>MK-810160</b>		L=116
Bellow Set, drive shaft	2.0	ATM; with clamps;	<b>MK-810160</b>		L=116

**SHARAN (7N1, 7N2)** 05/2010 → 05/2012

Alternator Freewheel Clutch	2.0 TDI, 2.0 TDI 4motion		<b>F5-1004</b>		
Alternator Freewheel Clutch	1.8 TSI, 2.0 TSI		<b>F5-1044</b>		
Alternator Freewheel Clutch	1.4 TSI		<b>F5-1064</b>		
Control Arm-/Trailing Arm Bush	1.4 TSI, 2.0 TDI, 2.0 TDI 4motion, 2.0 TSI		<b>F8-5633</b>		
Protective Cap/Bellow, shock absorber	1.4 TSI, 1.8 TSI, 2.0 TDI, 2.0 TDI 4motion, 2.0 TSI	for OE: 1JA, 1JC, F0A;	<b>F8-6044</b>		H=160
Protective Cap/Bellow, shock absorber	1.4 TSI, 1.8 TSI, 2.0 TDI, 2.0 TDI 4motion, 2.0 TSI		<b>F8-6044</b>		H=160
Belt Pulley, crankshaft	2.0 TDI, 2.0 TDI 4motion	Number of Ribs: 5; Parameter: 6PK	<b>F8-6572</b>		
Control Arm-/Trailing Arm Bush	1.4 TSI, 2.0 TDI, 2.0 TSI	01/2011 →; for OE: F0A, F4F; Aluminium;  not for special purpose vehicles	<b>F8-6701</b>		
Control Arm-/Trailing Arm Bush	1.4 TSI, 2.0 TDI, 2.0 TSI	Aluminium	<b>F8-6701</b>		
Control Arm-/Trailing Arm Bush	2.0 TDI 4motion	for OE: F0A, F4F; Aluminium;  not for special purpose vehicles	<b>F8-6701</b>		
Control Arm-/Trailing Arm Bush	1.4 TSI, 2.0 TDI, 2.0 TSI		<b>F8-6736</b>		
Control Arm-/Trailing Arm Bush	1.4 TSI, 2.0 TDI, 2.0 TSI	01/2011 →; for OE: F0A, F4F;  not for special purpose vehicles	<b>F8-6736</b>		

<b>F5-1004</b>	<b>F5-1044</b>	<b>F5-1064</b>	<b>F8-5633</b>	<b>F8-6044</b>	<b>F8-6572</b>	<b>F8-6701</b>
Ref.Nr.: 038903119T	Ref.Nr.: 06B903119B	Ref.Nr.: 03C903119D	Ref.Nr.: 1K0407182A	Ref.Nr.: 3C0513425	Ref.Nr.: 038105243L	Ref.Nr.: 3C0199231A
<b>F8-6736</b>	<b>F8-7010</b>	<b>F8-7032</b>	<b>F8-7049</b>	<b>F8-7132</b>	<b>F8-7688</b>	<b>F8-8150</b>
Ref.Nr.: 1K0407183A	Ref.Nr.: 1056804	Ref.Nr.: 1118741	Ref.Nr.: 7M3399201H	Ref.Nr.: 6N0413175A	Ref.Nr.: 7M0413175A	Ref.Nr.: 1089033
<b>G9-664</b>	<b>G9-665</b>	<b>LM-10023S</b>	<b>MK-810160</b>			
Ref.Nr.: 1044571	Ref.Nr.: 7201717	Ref.Nr.: 7M0422831B	Ref.Nr.: 3D0 498 201			

Article Description



Article Nr.

Fitting Position



### SHARAN (7N1, 7N2)

05/2010 → 05/2012

Control Arm-/Trailing Arm Bush	2.0 TDI 4motion	for OE: F0A, F4F;  , not for special purpose vehicles	F8-6736		
Rubber Buffer, suspension	1.4 TSI, 1.8 TSI, 2.0 TDI, 2.0 TDI 4motion, 2.0 TSI	for OE: G03; <b>SP</b>	F8-7131		H=70
Protective Cap/Bellow, shock absorber	1.4 TSI, 1.8 TSI, 2.0 TDI, 2.0 TDI 4motion, 2.0 TSI		F8-7132		H=190
Rubber Buffer, suspension	1.4 TSI, 2.0 TDI	<b>ST</b>	F8-7174		H=80
Top Strut Mounting	1.4 TSI, 1.8 TSI, 2.0 TDI, 2.0 TDI 4motion, 2.0 TSI	for OE: 1JC, F0A+1JA; <b>SP</b> , <b>ST</b>	F8-7603		
Top Strut Mounting	1.4 TSI, 1.8 TSI, 2.0 TDI, 2.0 TDI 4motion, 2.0 TSI	for OE: 1JP;	F8-7603		
Top Strut Mounting	1.4 TSI, 1.8 TSI, 2.0 TDI, 2.0 TDI 4motion, 2.0 TSI	for OE: F4E+1JA, F4F+1JA, F5Z+1JA;  ,	F8-7603		
Rubber Buffer, suspension	1.4 TSI, 1.8 TSI, 2.0 TDI, 2.0 TDI 4motion, 2.0 TSI	for OE: 1JA; <b>ST</b>	F8-7815		H=153
Rubber Buffer, suspension	1.4 TSI, 1.8 TSI, 2.0 TDI, 2.0 TDI 4motion, 2.0 TSI	for OE: 1JC; <b>SP</b>	F8-7816		H=138
Protective Cap/Bellow, shock absorber	1.4 TSI, 1.8 TSI, 2.0 TDI, 2.0 TDI 4motion, 2.0 TSI	for OE: 1JA, 1JC, F4E, F4F, F5Z;  ; <b>SP</b> , <b>ST</b>	F8-7845		
Belt Pulley, crankshaft	2.0 TSI	Number of Ribs: 5; Parameter: 6PK	F8-7880		D=143
Engine Mounting	1.4 TSI	CAVA, CTHA	F8-7982		
Engine Mounting	1.8 TSI, 2.0 TDI, 2.0 TDI 4motion, 2.0 TSI		F8-7982		

### TIGUAN (5N\_)

09/2007 → 08/2009

Alternator Freewheel Clutch	2.0 TDI, 2.0 TDI 4motion		F5-1004		
Alternator Freewheel Clutch	2.0 TFSI 4motion, 2.0 TSI 4motion		F5-1044		
Alternator Freewheel Clutch	1.4 TSI, 1.4 TSI 4motion		F5-1064		
Control Arm-/Trailing Arm Bush	1.4 TSI, 1.4 TSI 4motion, 2.0 TDI, 2.0 TDI 4motion, 2.0 TFSI 4motion, 2.0 TSI 4motion		F8-5633		
Protective Cap/Bellow, shock absorber	1.4 TSI, 1.4 TSI 4motion, 2.0 TDI, 2.0 TDI 4motion, 2.0 TFSI 4motion, 2.0 TSI 4motion		F8-6044		H=160
Top Strut Mounting	1.4 TSI, 1.4 TSI 4motion, 2.0 TDI, 2.0 TDI 4motion, 2.0 TFSI 4motion, 2.0 TSI 4motion		F8-6284		
Belt Pulley, crankshaft	2.0 TDI 4motion	Number of Ribs: 5; Parameter: 6PK	F8-6396		H=41.6; d=30; Mounting points diam.[mm]=7, 8.6; D=139.7
Control Arm-/Trailing Arm Bush	1.4 TSI, 1.4 TSI 4motion, 2.0 TDI, 2.0 TDI 4motion, 2.0 TFSI 4motion		F8-6463		H=64; d=12; D=60
Anti-Friction Bearing	1.4 TSI, 1.4 TSI 4motion, 2.0 TDI, 2.0 TDI 4motion, 2.0 TFSI 4motion, 2.0 TSI 4motion		F8-6569		
Top Strut Mounting	1.4 TSI, 1.4 TSI 4motion, 2.0 TDI, 2.0 TDI 4motion, 2.0 TFSI 4motion, 2.0 TSI 4motion		F8-6570		
Belt Pulley, crankshaft	2.0 TDI	CFFB; Number of Ribs: 5; Parameter: 6PK	F8-6572		
Belt Pulley, crankshaft	2.0 TDI, 2.0 TDI 4motion	Number of Ribs: 5; Parameter: 6PK	F8-6572		
Control Arm-/Trailing Arm Bush	1.4 TSI, 1.4 TSI 4motion, 2.0 TDI, 2.0 TDI 4motion, 2.0 TFSI 4motion, 2.0 TSI 4motion	Aluminium	F8-6701		

<b>F5-1004</b>	<b>F5-1044</b>	<b>F5-1064</b>	<b>F8-5633</b>	<b>F8-6044</b>	<b>F8-6284</b>	<b>F8-6396</b>
Ref.Nr.: 038903119T	Ref.Nr.: 06B903119B	Ref.Nr.: 03C903119D	Ref.Nr.: 1K0407182A	Ref.Nr.: 3C0513425	Ref.Nr.: 6N0412249C	Ref.Nr.: 03G105243
<b>F8-6463</b>	<b>F8-6569</b>	<b>F8-6570</b>	<b>F8-6572</b>	<b>F8-6701</b>	<b>F8-6736</b>	<b>F8-7131</b>
Ref.Nr.: 1K0505541B	Ref.Nr.: 6N0412249C	Ref.Nr.: 1K0412331C	Ref.Nr.: 038105243L	Ref.Nr.: 3C0199231A	Ref.Nr.: 1K0407183A	Ref.Nr.: 1K0412303B
<b>F8-7132</b>	<b>F8-7174</b>	<b>F8-7603</b>	<b>F8-7815</b>	<b>F8-7816</b>	<b>F8-7845</b>	<b>F8-7880</b>
Ref.Nr.: 6N0413175A	Ref.Nr.: 1K0412303M	Ref.Nr.: 3C0513353	Ref.Nr.: 7N0511359	Ref.Nr.: 7N0511359A	Ref.Nr.: 3C0513425B	Ref.Nr.: 06H105243F

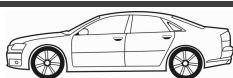
**Article Description****Article Nr.****Fitting Position**

<b>TIGUAN (5N_)</b>			<b>09/2007 → 08/2009</b>	
Control Arm-/Trailing Arm Bush	1.4 TSI, 1.4 TSI 4motion, 2.0 TDI, 2.0 TDI 4motion, 2.0 TFSI 4motion, 2.0 TSI 4motion		<b>F8-6736</b>	
Rubber Buffer, suspension	1.4 TSI, 2.0 TDI	BlueMotion; for OE: G06	<b>F8-7131</b>	H=70
Protective Cap/Bellow, shock absorber	1.4 TSI, 1.4 TSI 4motion, 2.0 TDI, 2.0 TDI 4motion, 2.0 TFSI 4motion, 2.0 TSI 4motion		<b>F8-7132</b>	H=190
Rubber Buffer, suspension	1.4 TSI, 1.4 TSI 4motion, 2.0 TDI, 2.0 TDI 4motion, 2.0 TFSI 4motion, 2.0 TSI 4motion	10/2011 →; for OE: 1JA; <b>ST</b>	<b>F8-7140</b>	H=133
Rubber Buffer, suspension	1.4 TSI, 1.4 TSI 4motion, 2.0 TDI, 2.0 TDI 4motion, 2.0 TFSI 4motion, 2.0 TSI 4motion	11/2011 →; for OE: 1JL; <b>ST</b>	<b>F8-7140</b>	H=133
Rubber Buffer, suspension	1.4 TSI, 2.0 TDI	for OE: UC1	<b>F8-7140</b>	H=133
Rubber Buffer, suspension	2.0 TDI 4motion	for OE: 1JA, 1JL; <b>ST</b>	<b>F8-7140</b>	H=133
Rubber Buffer, suspension	1.4 TSI 4motion, 2.0 TDI 4motion, 2.0 TFSI 4motion, 2.0 TSI 4motion	<b>SP, ST</b>	<b>F8-7174</b>	H=80
Rubber Buffer, suspension	1.4 TSI, 1.4 TSI 4motion, 2.0 TDI, 2.0 TDI 4motion, 2.0 TFSI 4motion, 2.0 TSI 4motion	$\neq$	<b>F8-7174</b>	H=80
Rubber Buffer, suspension	1.4 TSI, 2.0 TDI	for OE: G02, G03, G34, G73; <b>SP, ST</b>	<b>F8-7174</b>	H=80
Top Strut Mounting	1.4 TSI, 1.4 TSI 4motion, 2.0 TDI, 2.0 TDI 4motion, 2.0 TFSI 4motion, 2.0 TSI 4motion		<b>F8-7603</b>	
Rubber Buffer, suspension	1.4 TSI, 1.4 TSI 4motion, 2.0 TDI, 2.0 TDI 4motion, 2.0 TFSI 4motion, 2.0 TSI 4motion	; for OE: 1JL; <b>ST</b>	<b>F8-7836</b>	H=143
Rubber Buffer, suspension	1.4 TSI, 1.4 TSI 4motion, 2.0 TDI, 2.0 TDI 4motion, 2.0 TFSI 4motion, 2.0 TSI 4motion	for OE: 1JC; <b>SP</b>	<b>F8-7836</b>	H=143
Rubber Buffer, suspension	1.4 TSI, 1.4 TSI 4motion, 2.0 TDI, 2.0 TDI 4motion, 2.0 TFSI 4motion, 2.0 TSI 4motion	<b>ST</b>	<b>F8-7836</b>	H=143
Belt Pulley, crankshaft	2.0 TFSI 4motion, 2.0 TSI 4motion	Number of Ribs: 5; Parameter: 6PK	<b>F8-7880</b>	D=143
Engine Mounting	2.0 TDI, 2.0 TDI 4motion	for OE: 0EW, 0EX;	<b>F8-7962</b>	
Engine Mounting	2.0 TFSI 4motion	CCZA	<b>F8-7962</b>	
Engine Mounting	2.0 TFSI 4motion	CCZC	<b>F8-7962</b>	
Engine Mounting	1.4 TSI	BWK, CAVA, CTHA	<b>F8-7982</b>	
Engine Mounting	1.4 TSI 4motion	CAVA, CTHA	<b>F8-7982</b>	
Engine Mounting	1.4 TSI, 1.4 TSI 4motion, 2.0 TDI, 2.0 TSI 4motion		<b>F8-7982</b>	
Engine Mounting	2.0 TDI 4motion	CFFA	<b>F8-7982</b>	
Engine Mounting	2.0 TDI 4motion	CFFB, CLJA	<b>F8-7982</b>	
Engine Mounting	2.0 TDI 4motion	CFGB	<b>F8-7982</b>	
Engine Mounting	2.0 TFSI 4motion	CAWA	<b>F8-7982</b>	
Engine Mounting	2.0 TFSI 4motion	CAWB, CCTA	<b>F8-7982</b>	
<b>TOUAREG (7LA, 7L6, 7L7)</b>			<b>10/2002 → 05/2010</b>	
Dust Cover Kit, shock absorber	2.5 R5 TDI, 3.0 V6 TDI, 3.2 V6, 3.6 V6 FSI, 4.2 V8, 4.2 V8 FSI		<b>AK-735188</b>	



Article Description



Article Nr.

Fitting Position



TOUAREG (7LA, 7L6, 7L7)		10/2002 → 05/2010	
Dust Cover Kit, shock absorber	2.5 R5 TDI, 3.0 V6 TDI, 3.2 V6, 3.6 V6 FSI, 4.2 V8, 4.2 V8 FSI		AK-735189
Dust Cover Kit, shock absorber	All Models	for OE: 1BK;	AK-735190
Dust Cover Kit, shock absorber	All Models		AK-735191
Alternator Freewheel Clutch	2.5 R5 TDI, 5.0 R50 TDI, 5.0 V10 TDI		F5-1103
Alternator Freewheel Clutch	3.0 V6 TDI		F5-1140
Control Arm-/Trailing Arm Bush	2.5 R5 TDI, 3.0 V6 TDI, 3.2 V6, 3.6 V6 FSI, 4.2 V8, 4.2 V8 FSI, 5.0 R50 TDI, 5.0 V10 TDI, 6.0 W12		F8-5301
Control Arm-/Trailing Arm Bush	2.5 R5 TDI, 3.0 V6 TDI, 3.2 V6, 3.6 V6 FSI, 4.2 V8, 4.2 V8 FSI, 5.0 R50 TDI, 5.0 V10 TDI, 6.0 W12		F8-6705
Control Arm-/Trailing Arm Bush	All Models		F8-6706
Control Arm-/Trailing Arm Bush	2.5 R5 TDI, 3.0 V6 TDI, 3.2 V6, 3.6 V6 FSI, 4.2 V8, 4.2 V8 FSI, 5.0 R50 TDI, 5.0 V10 TDI, 6.0 W12		F8-6707
Protective Cap/Bellow, shock absorber	2.5 R5 TDI, 3.0 TDI, 3.0 V6 TDI, 3.2 V6, 3.6 V6 FSI, 4.2 V8, 4.2 V8 FSI, 5.0 R50 TDI, 5.0 V10 TDI, 6.0 W12	for OE: 1BA, 1BE; ; ;	F8-7804
Protective Cap/Bellow, shock absorber	2.5 R5 TDI, 3.0 TDI, 3.0 V6 TDI, 3.2 V6, 3.6 V6 FSI, 4.2 V8, 4.2 V8 FSI, 5.0 R50 TDI, 5.0 V10 TDI, 6.0 W12	for OE: 1BA, 1BE; ; ;	F8-7804
Rubber Buffer, suspension	All Models	for OE: 1BK; ;	F8-7805
Protective Cap/Bellow, shock absorber	2.5 R5 TDI, 3.0 TDI, 3.0 V6 TDI, 3.2 V6, 3.6 V6 FSI, 4.2 V8, 4.2 V8 FSI, 5.0 R50 TDI, 5.0 V10 TDI, 6.0 W12	;	F8-7806
Protective Cap/Bellow, shock absorber	2.5 R5 TDI, 3.0 TDI, 3.0 V6 TDI, 3.2 V6, 3.6 V6 FSI, 4.2 V8, 4.2 V8 FSI, 5.0 R50 TDI, 5.0 V10 TDI, 6.0 W12	;	F8-7806
Rubber Buffer, suspension	All Models	for OE: 1BA;	F8-7807
Rubber Buffer, suspension	All Models	;	F8-7808
Control Arm-/Trailing Arm Bush	2.5 R5 TDI, 3.0 TDI, 3.0 V6 TDI, 3.6 V6 FSI, 4.2 V8 FSI, 5.0 R50 TDI, 5.0 V10 TDI, 6.0 W12	07/2008 →	F8-7875
Control Arm-/Trailing Arm Bush	2.5 R5 TDI, 3.0 TDI, 3.0 V6 TDI, 3.6 V6 FSI, 4.2 V8 FSI, 5.0 R50 TDI, 5.0 V10 TDI, 6.0 W12	for OE: 1LT, 1LU	F8-7875
Mounting, axle beam	All Models		F8-8131
Bellow, steering	All Models	with clamps	LM-10100S
TOUAREG (7P5)		01/2010 →	
Alternator Freewheel Clutch	3.0 V6 TDI		F5-1140
Protective Cap/Bellow, shock absorber	3.0 V6 TDI, 3.0 V6 TSI, 3.0 V6 TSI Hybrid, 3.6 V6 FSI, 4.2 V8 FSI, 4.2 V8 TDI	for OE: 1BA, 1BE; ; ;	F8-7804
Protective Cap/Bellow, shock absorber	3.0 V6 TDI, 3.0 V6 TSI, 3.0 V6 TSI Hybrid, 3.6 V6 FSI, 4.2 V8 FSI, 4.2 V8 TDI	for OE: 1BA, 1BE; ; ;	F8-7804
Control Arm-/Trailing Arm Bush	3.0 V6 TDI, 3.0 V6 TSI, 3.0 V6 TSI Hybrid, 3.6 V6 FSI, 4.2 V8 FSI, 4.2 V8 TDI		F8-7875
Control Arm-/Trailing Arm Bush	3.0 V6 TDI	CASD, CJMA	F8-8091

						
<b>AK-735189</b>	<b>AK-735190</b>	<b>AK-735191</b>	<b>F5-1103</b>	<b>F5-1140</b>	<b>F8-5301</b>	<b>F8-6705</b>
Ref.Nr.: 7L0412137	Ref.Nr.: 7L0412303A	Ref.Nr.: 7L0498137	Ref.Nr.: 070903201C	Ref.Nr.: 059903119L	Ref.Nr.: 95534324301	Ref.Nr.: 7L0407077
						
<b>F8-6706</b>	<b>F8-6707</b>	<b>F8-7804</b>	<b>F8-7805</b>	<b>F8-7806</b>	<b>F8-7807</b>	<b>F8-7808</b>
Ref.Nr.: 7L0407182C	Ref.Nr.: 7L0407183A	Ref.Nr.: 7L0412137	Ref.Nr.: 7L0412303A	Ref.Nr.: 7L0498137	Ref.Nr.: 7L0512131B	Ref.Nr.: 7L0512131C
						
<b>F8-7875</b>	<b>F8-8091</b>	<b>F8-8131</b>	<b>LM-10100S</b>			
Ref.Nr.: 7L0407182D	Ref.Nr.: 7P0407077	Ref.Nr.: 7L0499035A	Ref.Nr.: 32106765782			

**Article Description****Article Nr.****Fitting Position**

<b>TOUAREG (7P5)</b>		<b>01/2010 →</b>	
Control Arm-/Trailing Arm Bush	3.0 V6 TDI, 3.0 V6 TSI, 3.0 V6 TSI Hybrid, 3.6 V6 FSI, 4.2 V8 FSI, 4.2 V8 TDI		<b>F8-8091</b>
Mounting, axle beam	3.0 V6 TDI, 3.0 V6 TSI, 3.0 V6 TSI Hybrid, 3.6 V6 FSI, 4.2 V8 FSI		<b>F8-8131</b> H=62; d=23; D=93
Bellow, steering	3.0 V6 TDI, 3.0 V6 TSI, 3.0 V6 TSI Hybrid, 3.6 V6 FSI, 4.2 V8 FSI, 4.2 V8 TDI	with clamps	<b>LM-10100S</b> d1=15.5; d2=66; L [mm]=195
<b>TOURAN (1T1, 1T2)</b>		<b>02/2003 → 05/2010</b>	
Alternator Freewheel Clutch	1.6, 1.9 TDI, 2.0 EcoFuel, 2.0 FSI, 2.0 TDI, 2.0 TDI 16V		<b>F5-1004</b>
Alternator Freewheel Clutch	1.4 FSI, 1.4 TSI, 1.4 TSI EcoFuel		<b>F5-1064</b>
Control Arm-/Trailing Arm Bush	All Models		<b>F8-5633</b>
Belt Pulley, crankshaft	2.0 FSI		<b>F8-5650</b>
Top Strut Mounting	All Models		<b>F8-6284</b>
Top Strut Mounting	1.4 TSI, 1.6, 1.6 FSI, 1.9 TDI, 2.0 FSI, 2.0 TDI, 2.0 TDI 16V	ch.→1T-6-157500; for OE: 1K0 513 353 J; Shape Oval	<b>F8-6350</b>
Belt Pulley, crankshaft	1.9 TDI, 2.0 TDI, 2.0 TDI 16V	Number of Ribs: 5; Parameter: 6PK	<b>F8-6396</b> H=41.6; d=30; Mounting points diam.[mm]=7, 8.6; D=139.7
Control Arm-/Trailing Arm Bush	All Models	Aluminium	<b>F8-6424</b>
Control Arm-/Trailing Arm Bush	All Models	Aluminium	<b>F8-6425</b>
Control Arm-/Trailing Arm Bush	1.4 FSI, 1.4 TSI, 1.6, 1.6 FSI, 1.9 TDI, 2.0 EcoFuel, 2.0 FSI, 2.0 TDI, 2.0 TDI 16V		<b>F8-6463</b> H=64; d=12; D=60
Engine Mounting	2.0 TDI, 2.0 TDI 16V		<b>F8-6528</b>
Anti-Friction Bearing	All Models		<b>F8-6569</b>
Top Strut Mounting	All Models		<b>F8-6570</b>
Engine Mounting	1.6		<b>F8-6988</b>
Engine Mounting	2.0 EcoFuel, 2.0 FSI		<b>F8-6989</b>
Engine Mounting	1.6 FSI		<b>F8-6991</b>
Rubber Buffer, suspension	1.4 FSI, 1.4 TSI, 1.4 TSI EcoFuel, 1.6, 1.6 FSI, 1.9 TDI, 2.0 EcoFuel, 2.0 FSI, 2.0 TDI, 2.0 TDI 16V	for OE: G27, G28; <b>SP</b>	<b>F8-7131</b> H=70
Rubber Buffer, suspension	2.0 TDI	BMN; for OE: G27, G28; <b>SP</b>	<b>F8-7131</b> H=70
Protective Cap/Bellow, shock absorber	All Models		<b>F8-7132</b> H=190
Rubber Buffer, suspension	1.4 FSI, 1.4 TSI EcoFuel	for OE: 1JC; <b>SP</b>	<b>F8-7140</b> H=133
Rubber Buffer, suspension	1.4 TSI, 1.6, 1.6 FSI, 1.9 TDI, 2.0 EcoFuel, 2.0 FSI, 2.0 TDI, 2.0 TDI 16V	ch.1T-6-170001→; for OE: 1JC; <b>SP</b>	<b>F8-7140</b> H=133
Rubber Buffer, suspension	All Models	<b>ST</b>	<b>F8-7174</b> H=80
Rubber Buffer, suspension	All Models	ch.→1T-6-170 000; <b>ST</b>	<b>F8-7176</b> H=143

<b>F5-1004</b>	<b>F5-1064</b>	<b>F8-5633</b>	<b>F8-5650</b>	<b>F8-6284</b>	<b>F8-6350</b>	<b>F8-6396</b>
Ref.Nr.: 038903119T	Ref.Nr.: 03C903119D	Ref.Nr.: 1K0407182A	Ref.Nr.: 06A105243E	Ref.Nr.: 6N0412249C	Ref.Nr.: 1K0513353J	Ref.Nr.: 03G105243
<b>F8-6424</b>	<b>F8-6425</b>	<b>F8-6463</b>	<b>F8-6528</b>	<b>F8-6569</b>	<b>F8-6570</b>	<b>F8-6988</b>
Ref.Nr.: 1K0199232G	Ref.Nr.: 1K0199231J	Ref.Nr.: 1K0505541B	Ref.Nr.: 1K0 199 262 AT	Ref.Nr.: 6N0412249C	Ref.Nr.: 1K0412331C	Ref.Nr.: 1K0199262AL
<b>F8-6989</b>	<b>F8-6991</b>	<b>F8-7131</b>	<b>F8-7132</b>	<b>F8-7140</b>	<b>F8-7174</b>	<b>F8-7176</b>
Ref.Nr.: 1K0199262AM	Ref.Nr.: 1K0199262AK	Ref.Nr.: 1K0412303B	Ref.Nr.: 6N0413175A	Ref.Nr.: 3C0511359	Ref.Nr.: 1K0412303M	Ref.Nr.: 1K0511353R

Article Description



Article Nr.

Fitting Position



**TOURAN (1T1, 1T2)**

02/2003 → 05/2010

Rubber Buffer, suspension	1.4 TSI, 1.6, 1.6 FSI, 1.9 TDI, 2.0 EcoFuel, 2.0 FSI, 2.0 TDI, 2.0 TDI 16V	ch.→1T-6-170000; for OE: 1JC; <b>SP</b>	<b>F8-7600</b>		H=133
Top Strut Mounting	1.4 FSI, 1.4 TSI, 1.4 TSI EcoFuel, 1.6, 1.6 FSI, 1.9 TDI, 2.0 EcoFuel, 2.0 FSI, 2.0 TDI, 2.0 TDI 16V	Cross; for OE: 1JL; <b>DI</b>	<b>F8-7603</b>		
Top Strut Mounting	1.4 FSI, 2.0 TDI	for OE: 1JA, 1JB, 1JC; <b>Δ</b> , <b>SP</b> , <b>ST</b>	<b>F8-7603</b>		
Top Strut Mounting	1.4 TSI EcoFuel, 2.0 EcoFuel	for OE: 1JG	<b>F8-7603</b>		
Top Strut Mounting	1.4 TSI, 1.6, 1.6 FSI, 1.9 TDI, 2.0 FSI, 2.0 TDI, 2.0 TDI 16V	for OE: 3C0513353C; for OE: 1JA, 1JB, 1JC; Shape Round; <b>Δ</b> , <b>SP</b> , <b>ST</b>	<b>F8-7603</b>		
Protective Cap/Bellow, shock absorber	1.4 FSI	Cross; for OE: 1JL; <b>Δ</b>	<b>F8-7627</b>		H=178
Protective Cap/Bellow, shock absorber	1.4 FSI	for OE: 1JA; <b>ST</b>	<b>F8-7627</b>		H=178
Protective Cap/Bellow, shock absorber	1.4 FSI	for OE: 1JB; <b>Δ</b>	<b>F8-7627</b>		H=178
Protective Cap/Bellow, shock absorber	1.4 FSI	for OE: 1JC; <b>SP</b>	<b>F8-7627</b>		H=178
Protective Cap/Bellow, shock absorber	1.4 TSI EcoFuel, 2.0 EcoFuel	for OE: 1JG	<b>F8-7627</b>		H=178
Protective Cap/Bellow, shock absorber	1.4 TSI, 1.6, 1.6 FSI, 1.9 TDI, 2.0 FSI, 2.0 TDI, 2.0 TDI 16V	ch.1T-6-170001→; Cross; for OE: 1JL; <b>Δ</b>	<b>F8-7627</b>		H=178
Protective Cap/Bellow, shock absorber	1.4 TSI, 1.6, 1.6 FSI, 1.9 TDI, 2.0 FSI, 2.0 TDI, 2.0 TDI 16V	ch.1T-6-170001→; for OE: 1JA; <b>ST</b>	<b>F8-7627</b>		H=178
Protective Cap/Bellow, shock absorber	1.4 TSI, 1.6, 1.6 FSI, 1.9 TDI, 2.0 FSI, 2.0 TDI, 2.0 TDI 16V	ch.1T-6-170001→; for OE: 1JB; <b>Δ</b>	<b>F8-7627</b>		H=178
Protective Cap/Bellow, shock absorber	1.4 TSI, 1.6, 1.6 FSI, 1.9 TDI, 2.0 FSI, 2.0 TDI, 2.0 TDI 16V	ch.1T-6-170001→; for OE: 1JC; <b>SP</b>	<b>F8-7627</b>		H=178
Rubber Buffer, suspension	All Models	for OE: 1JB, 1JG, 1JL, G29, G31; <b>Δ</b>	<b>F8-7834</b>		H=90
Rubber Buffer, suspension	1.4 FSI	for OE: 1JA, 1JJ; <b>ST</b>	<b>F8-7836</b>		H=143
Rubber Buffer, suspension	1.4 FSI	for OE: 1JB, 1JL; <b>Δ</b>	<b>F8-7836</b>		H=143
Rubber Buffer, suspension	1.4 TSI EcoFuel, 2.0 EcoFuel	for OE: 1JG	<b>F8-7836</b>		H=143
Rubber Buffer, suspension	1.4 TSI, 1.6, 1.6 FSI, 1.9 TDI, 2.0 FSI, 2.0 TDI, 2.0 TDI 16V	ch.1T-6-170001→; for OE: 1JA, 1JJ; <b>ST</b>	<b>F8-7836</b>		H=143
Rubber Buffer, suspension	1.4 TSI, 1.6, 1.6 FSI, 1.9 TDI, 2.0 FSI, 2.0 TDI, 2.0 TDI 16V	ch.1T-6-170001→; for OE: 1JB, 1JL; <b>Δ</b>	<b>F8-7836</b>		H=143
Control Arm-/Trailing Arm Bush	All Models		<b>F8-7902</b>		H=60; d=12; D=42
Control Arm-/Trailing Arm Bush	All Models		<b>F8-7907</b>		H=45; d=14; D=38
Control Arm-/Trailing Arm Bush	All Models		<b>F8-7908</b>		H=45; d=12; D=38
Control Arm-/Trailing Arm Bush	All Models		<b>F8-7909</b>		
Stabiliser Mounting	1.4 TSI, 1.6, 1.6 FSI, 1.9 TDI, 2.0 EcoFuel, 2.0 FSI, 2.0 TDI, 2.0 TDI 16V		<b>F8-7923</b>		d=20,7





**Article Description****Article Nr.****Fitting Position**

<b>TOURAN (1T1, 1T2)</b>				<b>02/2003 → 05/2010</b>	
Stabiliser Mounting	1.4 TSI, 1.6, 1.6 FSI, 1.9 TDI, 2.0 EcoFuel, 2.0 FSI, 2.0 TDI, 2.0 TDI 16V		<b>F8-7930</b>		d=18,5
Engine Mounting	1.9 TDI		<b>F8-7958</b>		
Engine Mounting	1.4 FSI, 1.4 TSI	ch.1K-9-900 001→	<b>F8-7959</b>		
Engine Mounting	1.6, 1.6 FSI		<b>F8-7960</b>		
Engine Mounting	1.4 TSI	BMY;  6-speed	<b>F8-7961</b>		
Engine Mounting	1.6 FSI	6-speed	<b>F8-7961</b>		
Engine Mounting	1.9 TDI	6-speed	<b>F8-7961</b>		
Engine Mounting	2.0 FSI	AXW, BLX, BLY;  6-speed	<b>F8-7961</b>		
Engine Mounting	1.9 TDI	BXJ; Transmission Type: DSG	<b>F8-7962</b>		
Engine Mounting	1.9 TDI, 2.0 TDI, 2.0 TDI 16V	Transmission Type: DSG	<b>F8-7962</b>		
Engine Mounting	1.6, 1.6 FSI, 2.0 EcoFuel		<b>F8-7965</b>		
Engine Mounting	1.9 TDI, 2.0 FSI, 2.0 TDI, 2.0 TDI 16V		<b>F8-7966</b>		
Engine Mounting	1.6 FSI, 1.9 TDI, 2.0 TDI, 2.0 TDI 16V		<b>F8-7981</b>		
Engine Mounting	1.9 TDI	BKC, BLS, BXE	<b>F8-7981</b>		
Engine Mounting	2.0 FSI	6-speed	<b>F8-7981</b>		
Engine Mounting	1.4 FSI, 1.4 TSI, 1.4 TSI EcoFuel, 1.6, 1.6 FSI, 1.9 TDI, 2.0 EcoFuel, 2.0 TDI, 2.0 TDI 16V		<b>F8-7982</b>		
Engine Mounting	2.0 FSI	AXW, BLR, BLX, BLY, BVZ	<b>F8-7982</b>		
Engine Mounting	2.0 TDI	BMN	<b>F8-7982</b>		
Engine Mounting	2.0 TDI, 2.0 TDI 16V	6-speed	<b>F8-8152</b>		
<b>TOURAN (1T3)</b>				<b>05/2010 → 05/2015</b>	
Alternator Freewheel Clutch	1.6 TDI, 2.0 TDI		<b>F5-1004</b>		
Alternator Freewheel Clutch	1.2 TSI, 1.4 TSI, 1.4 TSI EcoFuel		<b>F5-1064</b>		
Control Arm-/Trailing Arm Bush	1.2 TSI, 1.4 TSI, 1.4 TSI EcoFuel, 1.6 TDI, 2.0 TDI		<b>F8-5633</b>		
Rubber Buffer, suspension	1.2 TSI	for OE: G12;	<b>F8-6041</b>		H=53
Protective Cap/Bellow, shock absorber	1.2 TSI, 1.4 TSI, 1.4 TSI EcoFuel, 1.6 TDI, 2.0 TDI	for OE: 1JP;	<b>F8-6044</b>		H=160
Protective Cap/Bellow, shock absorber	1.2 TSI, 1.4 TSI, 1.4 TSI EcoFuel, 1.6 TDI, 2.0 TDI	for OE: UA1	<b>F8-6044</b>		H=160
Top Strut Mounting	1.2 TSI, 1.4 TSI, 1.4 TSI EcoFuel, 1.6 TDI, 2.0 TDI		<b>F8-6284</b>		
Anti-Friction Bearing	1.2 TSI, 1.4 TSI, 1.4 TSI EcoFuel, 1.6 TDI, 2.0 TDI		<b>F8-6569</b>		
Top Strut Mounting	1.2 TSI, 1.4 TSI, 1.4 TSI EcoFuel, 1.6 TDI, 2.0 TDI		<b>F8-6570</b>		
Belt Pulley, crankshaft	1.6 TDI, 2.0 TDI	Number of Ribs: 5; Parameter: 6PK	<b>F8-6572</b>		
Rubber Buffer, suspension	1.2 TSI, 1.4 TSI, 1.6 TDI, 2.0 TDI	for OE: G01;	<b>F8-7131</b>		H=70
Rubber Buffer, suspension	1.2 TSI, 1.4 TSI, 1.6 TDI, 2.0 TDI	for OE: G27;	<b>F8-7131</b>		H=70

<b>F5-1004</b>	<b>F5-1064</b>	<b>F8-5633</b>	<b>F8-6041</b>	<b>F8-6044</b>	<b>F8-6284</b>	<b>F8-6569</b>
Ref.Nr.: 038903119T	Ref.Nr.: 03C903119D	Ref.Nr.: 1K0407182A	Ref.Nr.: 1J0412303	Ref.Nr.: 3C0513425	Ref.Nr.: 6N0412249C	Ref.Nr.: 6N0412249C
<b>F8-6570</b>	<b>F8-6572</b>	<b>F8-7131</b>	<b>F8-7132</b>	<b>F8-7930</b>	<b>F8-7958</b>	<b>F8-7959</b>
Ref.Nr.: 1K0412331C	Ref.Nr.: 038105243L	Ref.Nr.: 1K0412303B	Ref.Nr.: 6N0413175A	Ref.Nr.: 1K0511327AP	Ref.Nr.: 1K0199262AS	Ref.Nr.: 1K0199262CG
<b>F8-7960</b>	<b>F8-7961</b>	<b>F8-7962</b>	<b>F8-7965</b>	<b>F8-7966</b>	<b>F8-7981</b>	<b>F8-7982</b>
Ref.Nr.: 1K0199555L	Ref.Nr.: 1K0199555N	Ref.Nr.: 1K0199555Q	Ref.Nr.: 1K0199855BA	Ref.Nr.: 1K0199855BB	Ref.Nr.: 1K0199867Q	Ref.Nr.: 1K0199868Q

**Article Description**

**Article Nr.**
**Fitting Position**

**TOURAN (1T3)**
**05/2010 → 05/2015**

Protective Cap/Bellow, shock absorber	1.2 TSI, 1.4 TSI, 1.4 TSI EcoFuel, 1.6 TDI, 2.0 TDI		<b>F8-7132</b>		H=190
Rubber Buffer, suspension	1.2 TSI, 1.4 TSI, 1.6 TDI, 2.0 TDI	for OE: 1JC; <b>SP</b>	<b>F8-7140</b>		H=133
Rubber Buffer, suspension	All Models	for OE: G24, G73; <b>ST</b>	<b>F8-7174</b>		H=80
Top Strut Mounting	1.2 TSI, 1.4 TSI, 1.4 TSI EcoFuel, 1.6 TDI, 2.0 TDI	Cross; for OE: 1JL; <b>QI</b>	<b>F8-7603</b>		
Top Strut Mounting	1.2 TSI, 1.4 TSI, 1.6 TDI, 2.0 TDI	for OE: 1JA, 1JB, 1JC, 1JM, UA1; <b>Δ</b> , <b>SP</b> , <b>ST</b>	<b>F8-7603</b>		
Top Strut Mounting	1.2 TSI, 1.4 TSI, 1.6 TDI, 2.0 TDI	for OE: 1JP; <b>↑</b>	<b>F8-7603</b>		
Top Strut Mounting	1.4 TSI EcoFuel	for OE: 1JC	<b>F8-7603</b>		
Protective Cap/Bellow, shock absorber	1.2 TSI, 1.4 TSI, 1.6 TDI, 2.0 TDI	Cross; for OE: 1JL; <b>Δ</b>	<b>F8-7627</b>		H=178
Protective Cap/Bellow, shock absorber	1.2 TSI, 1.4 TSI, 1.6 TDI, 2.0 TDI	for OE: 1JA; <b>ST</b>	<b>F8-7627</b>		H=178
Protective Cap/Bellow, shock absorber	1.2 TSI, 1.4 TSI, 1.6 TDI, 2.0 TDI	for OE: 1JB; <b>Δ</b>	<b>F8-7627</b>		H=178
Protective Cap/Bellow, shock absorber	1.2 TSI, 1.4 TSI, 1.6 TDI, 2.0 TDI	for OE: 1JC; <b>SP</b>	<b>F8-7627</b>		H=178
Protective Cap/Bellow, shock absorber	1.4 TSI EcoFuel	for OE: 1JG	<b>F8-7627</b>		H=178
Rubber Buffer, suspension	1.2 TSI, 1.4 TSI, 1.4 TSI EcoFuel, 1.6 TDI, 2.0 TDI	for OE: 1JB, 1JG, 1JL, G29, G31; <b>Δ</b>	<b>F8-7834</b>		H=90
Rubber Buffer, suspension	1.2 TSI, 1.4 TSI, 1.6 TDI, 2.0 TDI	for OE: 1JA, UA1; <b>ST</b>	<b>F8-7836</b>		H=143
Rubber Buffer, suspension	1.2 TSI, 1.4 TSI, 1.6 TDI, 2.0 TDI	for OE: 1JB, 1JL, 1JM; <b>Δ</b>	<b>F8-7836</b>		H=143
Rubber Buffer, suspension	1.4 TSI EcoFuel	for OE: 1JG	<b>F8-7836</b>		H=143
Protective Cap/Bellow, shock absorber	1.2 TSI, 1.4 TSI, 1.4 TSI EcoFuel, 1.6 TDI, 2.0 TDI	05/2011 →; for OE: 1JA, 1JC; <b>SP</b> , <b>ST</b>	<b>F8-7845</b>		
Protective Cap/Bellow, shock absorber	1.2 TSI, 1.4 TSI, 1.4 TSI EcoFuel, 1.6 TDI, 2.0 TDI	05/2011 →; for OE: 1JG; <b>QI</b>	<b>F8-7845</b>		
Protective Cap/Bellow, shock absorber	2.0 TDI	for OE: 1JA, 1JC; <b>SP</b> , <b>ST</b>	<b>F8-7845</b>		
Protective Cap/Bellow, shock absorber	2.0 TDI	for OE: 1JG; <b>QI</b>	<b>F8-7845</b>		
Control Arm-/Trailing Arm Bush	1.2 TSI, 1.6 TDI, 2.0 TDI		<b>F8-7902</b>		H=60; d=12; D=42
Control Arm-/Trailing Arm Bush	1.2 TSI, 1.6 TDI, 2.0 TDI		<b>F8-7907</b>		H=45; d=14; D=38
Control Arm-/Trailing Arm Bush	1.2 TSI, 1.6 TDI, 2.0 TDI		<b>F8-7908</b>		H=45; d=12; D=38
Control Arm-/Trailing Arm Bush	1.2 TSI, 1.6 TDI, 2.0 TDI		<b>F8-7909</b>		
Engine Mounting	1.2 TSI, 1.4 TSI, 1.4 TSI EcoFuel, 1.6 TDI, 2.0 TDI		<b>F8-7982</b>		
Engine Mounting	1.4 TSI	CAVB	<b>F8-7982</b>		
Engine Mounting	2.0 TDI	CLCA	<b>F8-7982</b>		

<b>F8-7132</b>	<b>F8-7140</b>	<b>F8-7174</b>	<b>F8-7603</b>	<b>F8-7627</b>	<b>F8-7834</b>	<b>F8-7836</b>
Ref.Nr.: 6N0413175A	Ref.Nr.: 3C0511359	Ref.Nr.: 1K0412303M	Ref.Nr.: 3C0513353	Ref.Nr.: 1K0513425D	Ref.Nr.: 1K0412303H	Ref.Nr.: 1T0511359
<b>F8-7845</b>	<b>F8-7902</b>	<b>F8-7907</b>	<b>F8-7908</b>	<b>F8-7909</b>	<b>F8-7982</b>	<b>F8-8152</b>
Ref.Nr.: 3C0513425B	Ref.Nr.: 1K0505171C	Ref.Nr.: 1K0505203A	Ref.Nr.: 1K0505279A	Ref.Nr.: 1K0505553 A	Ref.Nr.: 1K0199868Q	Ref.Nr.: 1K0199555T



Article Description



Article Nr.

Fitting Position



<b>TOURAN (1T3)</b>				<b>05/2010 → 05/2015</b>	
Engine Mounting	2.0 TDI	6-speed	<b>F8-8152</b>		
<b>TRANSPORTER Mk II Bus</b>				<b>08/1967 → 04/1979</b>	
Stabiliser Mounting	All Models	ch.24-E-145001→	<b>F8-4054</b>		H=28; d=21; D1=39; D2=44
<b>TRANSPORTER Mk II Box</b>				<b>08/1970 → 07/1979</b>	
Stabiliser Mounting	All Models	ch.24-E-145001→	<b>F8-4054</b>		H=28; d=21; D1=39; D2=44
<b>TRANSPORTER Mk II Platform/Chassis</b>				<b>08/1968 → 07/1979</b>	
Stabiliser Mounting	All Models	ch.24-E-145001→	<b>F8-4054</b>		H=28; d=21; D1=39; D2=44
<b>TRANSPORTER / CARAVELLE Mk III Bus</b>				<b>05/1979 → 07/1992</b>	
Dust Cover Kit, shock absorber	All Models	Universal	<b>AK-735153</b>		
Control Arm-/Trailing Arm Bush	1.6, 1.6 D, 1.6 TD, 1.6 TD Syncro, 1.7 D, 1.9, 1.9 Syncro, 2.0, 2.1, 2.1 i, 2.1 Syncro		<b>F8-1012</b>		H1=19; H2=53; d=18; D1=36; D2=58
Engine Mounting	1.6 D, 1.6 TD, 1.7 D		<b>F8-3054</b>		H=89; d=14; W=76, 95
Mounting, radiator	1.6 D	ch.→24-C-175000	<b>F8-4011</b>		H1=16; H2=38; D=30; Outer Thread [mm]=M8 x 1,25
Engine Mounting	1.9, 1.9 Syncro, 2.0, 2.1, 2.1 CAT, 2.1 i, 2.1 Syncro		<b>F8-4014</b>		H1=42; H2=121; W=81
Engine Mounting	1.9, 1.9 Syncro, 2.0, 2.1, 2.1 CAT, 2.1 i, 2.1 Syncro		<b>F8-4015</b>		H=83; L=101; W=36
Holder, exhaust system	1.6 D, 1.6 TD, 1.6 TD Syncro, 1.7 D		<b>F8-4023</b>		H=15; d=8; L=92; Outer Thread [mm]=M8 x 1,25; T [mm]=76; W=38
Control Arm-/Trailing Arm Bush	All Models		<b>F8-4032</b>		H=84; d=12; D1=44; D2=49
Control Arm-/Trailing Arm Bush	1.6, 1.6 D, 1.6 TD, 1.6 TD Syncro, 1.7 D, 1.9, 1.9 Syncro, 2.0, 2.1, 2.1 i, 2.1 Syncro		<b>F8-4033</b>		H=32; d=25; D=62
Control Arm-/Trailing Arm Bush	1.6, 1.6 D, 1.6 TD, 1.6 TD Syncro, 1.7 D, 1.9, 1.9 Syncro, 2.0, 2.1, 2.1 i, 2.1 Syncro		<b>F8-4034</b>		H=39; d=25; D=66
Stabiliser Mounting	All Models		<b>F8-4053</b>		H=46; d=19; W=54
Stabiliser Mounting	All Models		<b>F8-4056</b>		H=30; d=27; L=51
Bellow, steering	All Models		<b>F8-4071</b>		d1=25; d2=42; L=170; D1=37; D2=49
Bellow, driveshaft	All Models		<b>F8-4081</b>		H=97; D1=30; D2=103
Control Arm-/Trailing Arm Bush	All Models		<b>F8-4082</b>		H=75; d=12; D1=48; D2=54
Supporting Ring, suspension strut bearing	All Models		<b>F8-6261</b>		
Bellow, steering	All Models	with clamps	<b>LM-10031S</b>		d1=25; d2=42; L [mm]=180
<b>TRANSPORTER Mk III Box</b>				<b>05/1979 → 07/1992</b>	
Dust Cover Kit, shock absorber	1.6, 1.6 D, 1.6 TD, 1.6 TD Syncro, 1.7 D, 1.9, 1.9 Syncro, 2.0, 2.1, 2.1 i, 2.1 Syncro	Universal	<b>AK-735153</b>		

<b>AK-735153</b>	<b>F8-1012</b>	<b>F8-3054</b>	<b>F8-4011</b>	<b>F8-4014</b>	<b>F8-4015</b>	<b>F8-4023</b>
Ref.Nr.:	Ref.Nr.: 251407077	Ref.Nr.: 251199201G	Ref.Nr.: 803121273	Ref.Nr.: 070199231	Ref.Nr.: 070199231A	Ref.Nr.: 068251393B
<b>F8-4032</b>	<b>F8-4033</b>	<b>F8-4034</b>	<b>F8-4053</b>	<b>F8-4054</b>	<b>F8-4056</b>	<b>F8-4071</b>
Ref.Nr.: 251407183	Ref.Nr.: 251407175	Ref.Nr.: 251407179	Ref.Nr.: 251411041C	Ref.Nr.: 251411045	Ref.Nr.: 701411041D	Ref.Nr.: 251419831A
<b>F8-4081</b>	<b>F8-4082</b>	<b>F8-6261</b>	<b>F8-8152</b>	<b>LM-10031S</b>		
Ref.Nr.: 211501149	Ref.Nr.: 251501131A	Ref.Nr.: 411513121	Ref.Nr.: 1K0199555T	Ref.Nr.: 251419831A		

Article Description



Article Nr.

Fitting Position



<b>TRANSPORTER Mk III Box</b>		<b>05/1979 → 07/1992</b>		
Control Arm-/Trailing Arm Bush	1.6, 1.6 D, 1.6 TD, 1.6 TD Syncro, 1.7 D, 1.9, 1.9 Syncro, 2.0, 2.1, 2.1 i, 2.1 Syncro		<b>F8-1012</b>	H1=19; H2=53; d=18; D1=36; D2=58
Engine Mounting	1.6 D, 1.6 TD, 1.7 D		<b>F8-3054</b>	H=89; d=14; W=76, 95
Mounting, radiator	1.6 D	ch.→24-C-175000	<b>F8-4011</b>	H1=16; H2=38; D=30; Outer Thread [mm]=M8 x 1,25
Engine Mounting	1.9, 1.9 Syncro, 2.0, 2.1, 2.1 i, 2.1 Syncro		<b>F8-4014</b>	H1=42; H2=121; W=81
Engine Mounting	1.9, 1.9 Syncro, 2.0, 2.1, 2.1 i, 2.1 Syncro		<b>F8-4015</b>	H=83; L=101; W=36
Holder, exhaust system	1.6 D, 1.6 TD, 1.6 TD Syncro		<b>F8-4023</b>	H=15; d=8; L=92; Outer Thread [mm]=M8 x 1,25; T [mm]=76; W=38
Control Arm-/Trailing Arm Bush	1.6, 1.6 D, 1.6 TD, 1.6 TD Syncro, 1.7 D, 1.9, 1.9 Syncro, 2.0, 2.1, 2.1 i, 2.1 Syncro		<b>F8-4032</b>	H=84; d=12; D1=44; D2=49
Control Arm-/Trailing Arm Bush	1.6, 1.6 D, 1.6 TD, 1.6 TD Syncro, 1.7 D, 1.9, 1.9 Syncro, 2.0, 2.1, 2.1 i, 2.1 Syncro		<b>F8-4033</b>	H=32; d=25; D=62
Control Arm-/Trailing Arm Bush	1.6, 1.6 D, 1.6 TD, 1.6 TD Syncro, 1.7 D, 1.9, 1.9 Syncro, 2.0, 2.1, 2.1 i, 2.1 Syncro		<b>F8-4034</b>	H=39; d=25; D=66
Stabiliser Mounting	1.6, 1.6 D, 1.6 TD, 1.6 TD Syncro, 1.7 D, 1.9, 1.9 Syncro, 2.0, 2.1, 2.1 i, 2.1 Syncro		<b>F8-4053</b>	H=46; d=19; W=54
Stabiliser Mounting	1.6, 1.6 D, 1.6 TD, 1.6 TD Syncro, 1.7 D, 1.9, 1.9 Syncro, 2.0, 2.1, 2.1 i, 2.1 Syncro		<b>F8-4056</b>	H=30; d=27; L=51
Bellow, steering	1.6, 1.6 D, 1.6 TD, 1.6 TD Syncro, 1.7 D, 1.9, 1.9 Syncro, 2.0, 2.1, 2.1 i, 2.1 Syncro		<b>F8-4071</b>	d1=25; d2=42; L=170; D1=37; D2=49
Bellow, driveshaft	1.6, 1.6 D, 1.6 TD, 1.6 TD Syncro, 1.7 D, 1.9, 1.9 Syncro, 2.0, 2.1, 2.1 i, 2.1 Syncro		<b>F8-4081</b>	H=97; D1=30; D2=103
Control Arm-/Trailing Arm Bush	1.6, 1.6 D, 1.6 TD, 1.6 TD Syncro, 1.7 D, 1.9, 1.9 Syncro, 2.0, 2.1, 2.1 i, 2.1 Syncro		<b>F8-4082</b>	H=75; d=12; D1=48; D2=54
Supporting Ring, suspension strut bearing	All Models		<b>F8-6261</b>	
Bellow, steering	All Models	with clamps	<b>LM-10031S</b>	d1=25; d2=42; L [mm]=180
<b>TRANSPORTER Mk III Platform/Chassis</b>		<b>05/1979 → 07/1992</b>		
Dust Cover Kit, shock absorber	1.6 D, 1.6 TD, 1.6 TD Syncro, 1.7 D, 1.9, 1.9 Syncro, 2.0, 2.1, 2.1 i, 2.1 Syncro	Universal	<b>AK-735153</b>	
Control Arm-/Trailing Arm Bush	1.6 TD, 1.6 TD Syncro, 1.7 D, 1.9, 1.9 Syncro, 2.0, 2.1, 2.1 i, 2.1 Syncro		<b>F8-1012</b>	H1=19; H2=53; d=18; D1=36; D2=58
Engine Mounting	1.6 TD, 1.7 D		<b>F8-3054</b>	H=89; d=14; W=76, 95
Mounting, radiator	1.6 D	ch.→24-C-175000	<b>F8-4011</b>	H1=16; H2=38; D=30; Outer Thread [mm]=M8 x 1,25
Engine Mounting	1.9, 1.9 Syncro, 2.0, 2.1, 2.1 i, 2.1 Syncro		<b>F8-4014</b>	H1=42; H2=121; W=81
Engine Mounting	1.9, 1.9 Syncro, 2.0, 2.1, 2.1 i, 2.1 Syncro		<b>F8-4015</b>	H=83; L=101; W=36
Holder, exhaust system	1.6 TD, 1.6 TD Syncro		<b>F8-4023</b>	H=15; d=8; L=92; Outer Thread [mm]=M8 x 1,25; T [mm]=76; W=38

<b>AK-735153</b>	<b>F8-1012</b>	<b>F8-3054</b>	<b>F8-4011</b>	<b>F8-4014</b>	<b>F8-4015</b>	<b>F8-4023</b>
Ref.Nr.:	Ref.Nr.: 251407077	Ref.Nr.: 251199201G	Ref.Nr.: 803121273	Ref.Nr.: 070199231	Ref.Nr.: 070199231A	Ref.Nr.: 068251393B
<b>F8-4032</b>	<b>F8-4033</b>	<b>F8-4034</b>	<b>F8-4053</b>	<b>F8-4056</b>	<b>F8-4071</b>	<b>F8-4081</b>
Ref.Nr.: 251407183	Ref.Nr.: 251407175	Ref.Nr.: 251407179	Ref.Nr.: 251411041C	Ref.Nr.: 701411041D	Ref.Nr.: 251419831A	Ref.Nr.: 211501149
<b>F8-4082</b>	<b>F8-6261</b>	<b>LM-10031S</b>				
Ref.Nr.: 251501131A	Ref.Nr.: 411513121	Ref.Nr.: 251419831A				



Article Description



Article Nr.

Fitting Position



**TRANSPORTER Mk III Platform/Chassis** 05/1979 → 07/1992

Control Arm-/Trailing Arm Bush	1.6 D, 1.6 TD, 1.6 TD Syncro, 1.7 D, 1.9, 1.9 Syncro, 2.0, 2.1, 2.1 i, 2.1 Syncro		<b>F8-4032</b>		H=84; d=12; D1=44; D2=49
Control Arm-/Trailing Arm Bush	1.6 TD, 1.6 TD Syncro, 1.7 D, 1.9, 1.9 Syncro, 2.0, 2.1, 2.1 i, 2.1 Syncro		<b>F8-4033</b>		H=32; d=25; D=62
Control Arm-/Trailing Arm Bush	1.6 TD, 1.6 TD Syncro, 1.7 D, 1.9, 1.9 Syncro, 2.0, 2.1, 2.1 i, 2.1 Syncro		<b>F8-4034</b>		H=39; d=25; D=66
Stabiliser Mounting	1.6 D, 1.6 TD, 1.6 TD Syncro, 1.7 D, 1.9, 1.9 Syncro, 2.0, 2.1, 2.1 i, 2.1 Syncro		<b>F8-4053</b>		H=46; d=19; W=54
Stabiliser Mounting	1.6 D, 1.6 TD, 1.6 TD Syncro, 1.7 D, 1.9, 1.9 Syncro, 2.0, 2.1, 2.1 i, 2.1 Syncro		<b>F8-4056</b>		H=30; d=27; L=51
Bellow, steering	1.6 D, 1.6 TD, 1.6 TD Syncro, 1.7 D, 1.9, 1.9 Syncro, 2.0, 2.1, 2.1 i, 2.1 Syncro		<b>F8-4071</b>		d1=25; d2=42; L=170; D1=37; D2=49
Bellow, driveshaft	1.6 D, 1.6 TD, 1.6 TD Syncro, 1.7 D, 1.9, 1.9 Syncro, 2.0, 2.1, 2.1 i, 2.1 Syncro		<b>F8-4081</b>		H=97; D1=30; D2=103
Control Arm-/Trailing Arm Bush	1.6 D, 1.6 TD, 1.6 TD Syncro, 1.7 D, 1.9, 1.9 Syncro, 2.0, 2.1, 2.1 i, 2.1 Syncro		<b>F8-4082</b>		H=75; d=12; D1=48; D2=54
Supporting Ring, suspension strut bearing	All Models		<b>F8-6261</b>		
Bellow, steering	All Models	with clamps	<b>LM-10031S</b>		d1=25; d2=42; L [mm]=180

**TRANSPORTER / CARAVELLE Mk IV Bus (70XB, 70XC, 7DB, 7DW, 7DK)** 09/1990 → 04/2003

Alternator Freewheel Clutch	2.0, 2.4 D, 2.4 D Syncro		<b>F5-1007</b>		
Alternator Freewheel Clutch	2.5 TDI, 2.5 TDI Syncro		<b>F5-1031</b>		
Control Arm-/Trailing Arm Bush	1.8, 1.9 D, 1.9 TD, 2.0, 2.4 D, 2.4 D Syncro, 2.5, 2.5 Syncro, 2.5 TDI, 2.5 TDI Syncro, 2.8 VR 6		<b>F7-2001</b>		H=60; d=12; D1=35; D2=38
Control Arm-/Trailing Arm Bush	1.8, 1.9 D, 1.9 TD, 2.0, 2.4 D, 2.4 D Syncro, 2.5, 2.5 Syncro, 2.5 TDI, 2.5 TDI Syncro, 2.8 VR 6	ch.→70-T-199999	<b>F7-2002</b>		H=60.2; d=14.2; D1=35.5; D2=38
Holder, exhaust system	1.8, 1.9 D, 1.9 TD, 2.0, 2.4 D, 2.4 D Syncro, 2.5, 2.5 Syncro, 2.5 TDI, 2.5 TDI Syncro, 2.8 VR 6		<b>F8-4025</b>		H=65; T [mm]=86; W=35
Clamp, silencer	1.8, 1.9 D, 1.9 TD, 2.0, 2.4 D, 2.4 D Syncro, 2.5, 2.5 Syncro, 2.5 TDI, 2.5 TDI Syncro, 2.8 VR 6	ch.→70-T-199999	<b>F8-4027</b>		H=17; W=53, 61
Control Arm-/Trailing Arm Bush	1.8, 1.9 D, 1.9 TD, 2.0, 2.4 D, 2.4 D Syncro, 2.5, 2.5 Syncro, 2.5 TDI, 2.5 TDI Syncro, 2.8 V6, 2.8 VR 6		<b>F8-4037</b>		H=60; d=12; D1=39; D2=40
Control Arm-/Trailing Arm Bush	1.8, 1.9 D, 1.9 TD, 2.0, 2.4 D, 2.4 D Syncro, 2.5, 2.5 Syncro, 2.5 TDI, 2.5 TDI Syncro, 2.8 VR 6	ch.70-M-083343→	<b>F8-4038</b>		H1=45; H2=60.2; d=14.2; D1=28.8; D2=45.5
Control Arm-/Trailing Arm Bush	1.9 D	ch.70-V-000001→	<b>F8-4039</b>		H=60; d=14.1; D1=40; D2=51.7
Control Arm-/Trailing Arm Bush	1.9 TD, 2.0, 2.4 D, 2.4 D Syncro, 2.5, 2.5 Syncro, 2.5 TDI, 2.5 TDI Syncro, 2.8 VR 6	ch.70-V-000001→; 05/1996 →	<b>F8-4039</b>		H=60; d=14.1; D1=40; D2=51.7
Control Arm-/Trailing Arm Bush	2.4 D, 2.5, 2.5 Syncro, 2.5 TDI, 2.8 V6		<b>F8-4039</b>		H=60; d=14.1; D1=40; D2=51.7
Bump Stop, stub axle	1.8, 1.9 D, 1.9 TD, 2.0, 2.4 D, 2.4 D Syncro, 2.5, 2.5 Syncro, 2.5 TDI, 2.5 TDI Syncro, 2.8 V6, 2.8 VR 6		<b>F8-4040</b>		H=48; D1=18; D2=54
Stabiliser Mounting	1.8, 1.9 D, 1.9 TD, 2.0, 2.4 D, 2.4 D Syncro, 2.5, 2.5 Syncro	ch.→70-T-199999	<b>F8-4055</b>		H=35; d=22.5; L=30

<b>F5-1007</b>	<b>F5-1031</b>	<b>F7-2001</b>	<b>F7-2002</b>	<b>F8-4025</b>	<b>F8-4027</b>	<b>F8-4032</b>
Ref.Nr.: 028903119AQ	Ref.Nr.: 021903119H	Ref.Nr.: 701407087	Ref.Nr.: 701407183	Ref.Nr.: 1H0253144	Ref.Nr.: 171253147A	Ref.Nr.: 251407183
<b>F8-4033</b>	<b>F8-4034</b>	<b>F8-4037</b>	<b>F8-4038</b>	<b>F8-4039</b>	<b>F8-4040</b>	<b>F8-4053</b>
Ref.Nr.: 251407175	Ref.Nr.: 251407179	Ref.Nr.: 701407077	Ref.Nr.: 701407140B	Ref.Nr.: 701407183C	Ref.Nr.: 701407303	Ref.Nr.: 251411041C
<b>F8-4055</b>	<b>F8-4056</b>	<b>F8-4071</b>	<b>F8-4072</b>	<b>F8-4081</b>	<b>F8-4082</b>	<b>F8-6261</b>
Ref.Nr.: 701411041	Ref.Nr.: 701411041D	Ref.Nr.: 251419831A	Ref.Nr.: 701419831	Ref.Nr.: 211501149	Ref.Nr.: 251501131A	Ref.Nr.: 411513121

Article Description



Article Nr.

Fitting Position



TRANSPORTER / CARAVELLE Mk IV Bus (70XB, 70XC, 7DB, 7DW, 7DK)			09/1990 → 04/2003		
Bellow, steering	1.8, 1.9 D, 1.9 TD, 2.0, 2.4 D, 2.4 D Syncro, 2.5, 2.5 Syncro, 2.5 TDI, 2.5 TDI Syncro, 2.8 VR 6		F8-4072		D1/D2=außen: Ø36/Ø55; D1=36; D2=55
Control Arm-/Trailing Arm Bush	1.8, 1.9 D, 1.9 TD, 2.0, 2.4 D, 2.4 D Syncro, 2.5, 2.5 Syncro, 2.5 TDI, 2.5 TDI Syncro, 2.8 VR 6		F8-4082		H=75; d=12; D1=48; D2=54
Control Arm-/Trailing Arm Bush	2.5 Syncro	AAF, ACU, AEU	F8-4082		H=75; d=12; D1=48; D2=54
Control Arm-/Trailing Arm Bush	1.8, 1.9 D, 1.9 TD, 2.0, 2.4 D, 2.4 D Syncro, 2.5, 2.5 Syncro, 2.5 TDI, 2.5 TDI Syncro, 2.8 VR 6		F8-4083		H=75; d=14; D1=48; D2=55
Belt Pulley, crankshaft	2.4 D, 2.4 D Syncro, 2.5, 2.5 Syncro, 2.5 TDI, 2.5 TDI Syncro		F8-5202		H=57.6; d=18.55; D=188
Belt Pulley, crankshaft	2.4 D, 2.4 D Syncro, 2.5, 2.5 Syncro, 2.5 TDI, 2.5 TDI Syncro	with fastening material	F8-5202K1		H=57.6; d=18.55; D=188
Engine Mounting	1.8, 1.9 D, 1.9 TD, 2.0, 2.4 D, 2.5, 2.5 TDI, 2.8 VR 6	4-speed	F8-5531		
Belt Pulley, crankshaft	1.9 D	ch.70-P-046679, 70-P-085001→; ch.→70-T-199000; Number of Ribs: 5; Parameter: 6PK;	F8-5649		H=31.5; d=30.02; Mounting points diam.[mm]=8.5; D1=161.5; D2=160.5
Belt Pulley, crankshaft	1.9 TD	ch.70-P-046679, 70-P-085001→; ch.→70-3-250000, 70-4-099000; Number of Ribs: 5; Parameter: 6PK;	F8-5649		H=31.5; d=30.02; Mounting points diam.[mm]=8.5; D1=161.5; D2=160.5
Supporting Ring, suspension strut bearing	1.8, 1.9 D, 1.9 TD, 2.0, 2.4 D, 2.4 D Syncro, 2.5, 2.5 Syncro, 2.5 TDI, 2.5 TDI Syncro, 2.8 VR 6		F8-6261		
Stabiliser Mounting	1.8, 1.9 D, 1.9 TD, 2.0, 2.4 D, 2.4 D Syncro, 2.5, 2.5 Syncro, 2.5 TDI, 2.5 TDI Syncro, 2.8 VR 6		F8-6708		d=23
Mounting, manual transmission	1.9 TD, 2.0, 2.4 D, 2.5 TDI, 2.8 VR 6	ch.70-T-200001→; 01/1996 →	F8-7041		d=13; L=62; D=34
Mounting, manual transmission	2.4 D Syncro	05/1996 →; Transmission Nr: 12086→;  5-speed	F8-7041		d=13; L=62; D=34
Mounting, manual transmission	2.5	ch.70-T-200001→; 01/1996 →;  ACU, AEU	F8-7041		d=13; L=62; D=34
Mounting, manual transmission	2.5 Syncro	05/1996 →;  ACU, AEU; Transmission Nr: 12086→;  5-speed	F8-7041		d=13; L=62; D=34
Mounting, manual transmission	2.5 Syncro	Transmission Nr: 12086→;  5-speed	F8-7041		d=13; L=62; D=34
Mounting, manual transmission	2.5 TDI	ACV, AUF	F8-7041		d=13; L=62; D=34
Mounting, manual transmission	2.5 TDI	AJT	F8-7041		d=13; L=62; D=34
Mounting, manual transmission	2.5, 2.8 V6		F8-7041		d=13; L=62; D=34
Mounting, manual transmission	1.8	ch.70-P-004343→;  5-speed	F8-7047		
Mounting, manual transmission	1.9 D, 1.9 TD, 2.0, 2.4 D	ch.70-P-004343→; ch.→70-T-199999;  5-speed	F8-7047		
Mounting, manual transmission	2.4 D Syncro	Transmission Nr: →11086;  5-speed	F8-7047		
Mounting, manual transmission	2.5	ch.70-P-004343→; ch.→70-T-199999;  AAF, ACU;  5-speed	F8-7047		



**Article Description****Article Nr.****Fitting Position****TRANSPORTER / CARAVELLE Mk IV Bus (70XB, 70XC, 7DB, 7DW, 7DK) 09/1990 → 04/2003**

Engine Mounting	1.9 TD, 2.0, 2.5 TDI, 2.8 VR 6	ch.70-T-200001→; 01/1996 →;	<b>F8-7748</b>		
Engine Mounting	2.4 D, 2.4 D Syncro	ch.70-T-200001→; 01/1996 →	<b>F8-7748</b>		
Engine Mounting	2.4 D, 2.5 Syncro, 2.5 TDI		<b>F8-7748</b>		
Engine Mounting	2.5	ch.70-T-200001→; 01/1996 →;  ACU, AEN, AEU; not for  AAF;	<b>F8-7748</b>		
Engine Mounting	2.5	ch.70-T-200001→; 01/1996 →;  ACU, AEN; not for  AAF, AEU;	<b>F8-7748</b>		
Engine Mounting	2.5	ch.70-X-000001→; 05/1998 →;  AET;	<b>F8-7748</b>		
Engine Mounting	2.5	APL, AVT;	<b>F8-7748</b>		
Engine Mounting	2.5 Syncro	ch.70-T-200001→; 01/1996 →;  ACU; not for  AAF, AEN, AEU	<b>F8-7748</b>		
Engine Mounting	2.5, 2.8 V6		<b>F8-7748</b>		
Engine Mounting	1.9 TD, 2.0, 2.8 VR 6	ch.70-T-200001→; 01/1996 →;	<b>F8-7749</b>		
Engine Mounting	2.5	ch.→70-W-200000;  AET; not for  APL, AVT;	<b>F8-7749</b>		
Engine Mounting	2.5	ch.70-T-200001→; 01/1996 →;  AEU; not for  AAF, ACU, AEN;	<b>F8-7749</b>		
Engine Mounting	2.5 Syncro	ch.70-T-200001→; 01/1996 →;  AEU; not for  AAF, ACU, AEN	<b>F8-7749</b>		
Engine Mounting	2.5 TDI	ch.→70-T-199999;  ACV; not for  AUF, AYC	<b>F8-7749</b>		
Engine Mounting	2.5 TDI	ch.70-T-200001→; 01/1996 →;  ACV, AYC; not for  AUF;	<b>F8-7749</b>		
Engine Mounting	2.5 TDI, 2.5 TDI Syncro		<b>F8-7749</b>		
Bellow, steering	1.8, 1.9 D, 1.9 TD, 2.0, 2.4 D, 2.4 D Syncro, 2.5, 2.5 Syncro, 2.5 TDI, 2.5 TDI Syncro, 2.8 Syncro, 2.8 V6, 2.8 VR 6	with clamps	<b>LM-10015S</b>		d1=25; d2=46; L [mm]=120
Bellow, steering	1.8, 1.9 D, 1.9 TD, 2.0, 2.4 D, 2.4 D Syncro, 2.5, 2.5 Syncro, 2.5 TDI, 2.5 TDI Syncro, 2.8 Syncro, 2.8 V6, 2.8 VR 6	with clamps	<b>LM-10017S</b>		d1=25; d2=54; L [mm]=126

**TRANSPORTER Mk IV Box (70XA) 07/1990 → 04/2003**

Alternator Freewheel Clutch	2.0, 2.4 D, 2.4 D Syncro		<b>F5-1007</b>		
Alternator Freewheel Clutch	2.5 TDI, 2.5 TDI Syncro		<b>F5-1031</b>		
Control Arm-/Trailing Arm Bush	1.9 D, 1.9 TD, 2.0, 2.4 D, 2.4 D Syncro, 2.5, 2.5 Syncro, 2.5 TDI, 2.5 TDI Syncro		<b>F7-2001</b>		H=60; d=12; D1=35; D2=38
Control Arm-/Trailing Arm Bush	1.9 D, 1.9 TD, 2.0, 2.4 D, 2.4 D Syncro, 2.5, 2.5 Syncro, 2.5 TDI, 2.5 TDI Syncro	ch.→70-T-199999	<b>F7-2002</b>		H=60.2; d=14.2; D1=35.5; D2=38
Holder, exhaust system	1.9 D, 1.9 TD, 2.0, 2.4 D, 2.4 D Syncro, 2.5, 2.5 Syncro, 2.5 TDI, 2.5 TDI Syncro		<b>F8-4025</b>		H=65; $\tau$ [mm]=86; W=35
Clamp, silencer	1.9 D, 1.9 TD, 2.0, 2.4 D, 2.4 D Syncro, 2.5, 2.5 Syncro, 2.5 TDI, 2.5 TDI Syncro	ch.→70-T-199999	<b>F8-4027</b>		H=17; W=53, 61

<b>F5-1007</b>	<b>F5-1031</b>	<b>F7-2001</b>	<b>F7-2002</b>	<b>F8-4025</b>	<b>F8-4027</b>	<b>F8-4037</b>
Ref.Nr.: 028903119AQ	Ref.Nr.: 021903119H	Ref.Nr.: 701407087	Ref.Nr.: 701407183	Ref.Nr.: 1H0253144	Ref.Nr.: 171253147A	Ref.Nr.: 701407077
<b>F8-7748</b>	<b>F8-7749</b>	<b>LM-10015S</b>	<b>LM-10017S</b>			
Ref.Nr.: 7D0199132D	Ref.Nr.: 7D0199132C	Ref.Nr.: 701419831	Ref.Nr.: 701419831			

Article Description



Article Nr.

Fitting Position



## TRANSPORTER Mk IV Box (70XA)

07/1990 → 04/2003

Control Arm-/Trailing Arm Bush	1.9 D, 1.9 TD, 2.0, 2.4 D, 2.4 D Syncro, 2.5, 2.5 Syncro, 2.5 TDI, 2.5 TDI Syncro		<b>F8-4037</b>		H=60; d=12; D1=39; D2=40
Control Arm-/Trailing Arm Bush	1.9 D, 1.9 TD, 2.0, 2.4 D, 2.4 D Syncro, 2.5, 2.5 Syncro, 2.5 TDI, 2.5 TDI Syncro	ch.70-M-083343→	<b>F8-4038</b>		H1=45; H2=60.2; d=14.2; D1=28.8; D2=45.5
Control Arm-/Trailing Arm Bush	1.9 D	ch.70-V-000001→	<b>F8-4039</b>		H=60; d=14.1; D1=40; D2=51.7
Control Arm-/Trailing Arm Bush	1.9 TD, 2.0, 2.4 D, 2.4 D Syncro, 2.5, 2.5 Syncro, 2.5 TDI	ch.70-V-000001→; 05/1996 →	<b>F8-4039</b>		H=60; d=14.1; D1=40; D2=51.7
Control Arm-/Trailing Arm Bush	2.4 D, 2.5, 2.5 Syncro, 2.5 TDI Syncro		<b>F8-4039</b>		H=60; d=14.1; D1=40; D2=51.7
Bump Stop, stub axle	1.9 D, 1.9 TD, 2.0, 2.4 D, 2.4 D Syncro, 2.5, 2.5 Syncro, 2.5 TDI, 2.5 TDI Syncro		<b>F8-4040</b>		H=48; D1=18; D2=54
Stabiliser Mounting	1.9 D, 1.9 TD, 2.0, 2.4 D, 2.4 D Syncro, 2.5, 2.5 Syncro	ch.→70-T-199999	<b>F8-4055</b>		H=35; d=22.5; L=30
Bellow, steering	1.9 D, 1.9 TD, 2.0, 2.4 D, 2.4 D Syncro, 2.5, 2.5 Syncro, 2.5 TDI, 2.5 TDI Syncro		<b>F8-4072</b>		D1/D2=außen: Ø36/Ø55; D1=36; D2=55
Control Arm-/Trailing Arm Bush	1.9 D, 1.9 TD, 2.0, 2.4 D, 2.4 D Syncro, 2.5, 2.5 Syncro, 2.5 TDI, 2.5 TDI Syncro, 2.8 VR6		<b>F8-4082</b>		H=75; d=12; D1=48; D2=54
Control Arm-/Trailing Arm Bush	2.5 Syncro	AAF, ACU, AEU	<b>F8-4082</b>		H=75; d=12; D1=48; D2=54
Control Arm-/Trailing Arm Bush	1.9 D, 1.9 TD, 2.0, 2.4 D, 2.4 D Syncro, 2.5, 2.5 Syncro, 2.5 TDI, 2.5 TDI Syncro		<b>F8-4083</b>		H=75; d=14; D1=48; D2=55
Belt Pulley, crankshaft	2.4 D, 2.4 D Syncro, 2.5, 2.5 Syncro, 2.5 TDI, 2.5 TDI Syncro		<b>F8-5202</b>		H=57.6; d=18.55; D=188
Belt Pulley, crankshaft	2.4 D, 2.4 D Syncro, 2.5, 2.5 Syncro, 2.5 TDI, 2.5 TDI Syncro	with fastening material	<b>F8-5202K1</b>		H=57.6; d=18.55; D=188
Engine Mounting	1.9 D, 1.9 TD, 2.0, 2.4 D, 2.5, 2.5 TDI	4-speed	<b>F8-5531</b>		
Belt Pulley, crankshaft	1.9 D	ch.70-P-046679, 70-P-085001→; ch.→70-T-199000; Number of Ribs: 5; Parameter: 6PK;	<b>F8-5649</b>		H=31.5; d=30.02; Mounting points diam.[mm]=8.5; D1=161.5; D2=160.5
Belt Pulley, crankshaft	1.9 TD	ch.70-P-046679, 70-P-085001→; ch.→70-3-250000, 70-4-099000; Number of Ribs: 5; Parameter: 6PK;	<b>F8-5649</b>		H=31.5; d=30.02; Mounting points diam.[mm]=8.5; D1=161.5; D2=160.5
Supporting Ring, suspension strut bearing	1.9 D, 1.9 TD, 2.0, 2.4 D, 2.4 D Syncro, 2.5, 2.5 Syncro, 2.5 TDI, 2.5 TDI Syncro, 2.8 VR6		<b>F8-6261</b>		
Stabiliser Mounting	1.9 TD, 2.4 D, 2.4 D Syncro, 2.5, 2.5 Syncro, 2.5 TDI, 2.5 TDI Syncro		<b>F8-6708</b>		d=23
Mounting, manual transmission	1.9 TD, 2.0, 2.4 D	ch.70-T-200001→; 01/1996 →	<b>F8-7041</b>		d=13; L=62; D=34
Mounting, manual transmission	2.4 D	ch.70-T-200001→; 01/1996 →;  AEU	<b>F8-7041</b>		d=13; L=62; D=34
Mounting, manual transmission	2.4 D Syncro	05/1996 →; Transmission Nr: 12086→;  5-speed	<b>F8-7041</b>		d=13; L=62; D=34
Mounting, manual transmission	2.5		<b>F8-7041</b>		d=13; L=62; D=34
Mounting, manual transmission	2.5	ch.70-T-200001→; 01/1996 →;  ACU, AEU	<b>F8-7041</b>		d=13; L=62; D=34

<b>F8-4037</b>	<b>F8-4038</b>	<b>F8-4039</b>	<b>F8-4040</b>	<b>F8-4055</b>	<b>F8-4072</b>	<b>F8-4082</b>
Ref.Nr.: 701407077	Ref.Nr.: 701407140B	Ref.Nr.: 701407183C	Ref.Nr.: 701407303	Ref.Nr.: 701411041	Ref.Nr.: 701419831	Ref.Nr.: 251501131A
<b>F8-4083</b>	<b>F8-5202</b>	<b>F8-5202K1</b>	<b>F8-5531</b>	<b>F8-5649</b>	<b>F8-6261</b>	<b>F8-6708</b>
Ref.Nr.: 701501131	Ref.Nr.: 074105251T	Ref.Nr.: 74105251N	Ref.Nr.: 701399201AE	Ref.Nr.: 028105243T	Ref.Nr.: 411513121	Ref.Nr.: 7D1411041
<b>F8-7041</b>						
Ref.Nr.: 701399661						

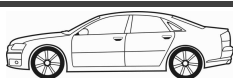

**Article Description****Article Nr.****Fitting Position**

<b>TRANSPORTER Mk IV Box (70XA)</b>			<b>07/1990 → 04/2003</b>		
Mounting, manual transmission	2.5 Syncro	05/1996 →;  ACU, AEU; Transmission Nr: 12086→;  5-speed	<b>F8-7041</b>		d=13; L=62; D=34
Mounting, manual transmission	2.5 Syncro, 2.5 TDI Syncro	Transmission Nr: 12086→;  5-speed	<b>F8-7041</b>		d=13; L=62; D=34
Mounting, manual transmission	2.5 TDI	ACV, AUF	<b>F8-7041</b>		d=13; L=62; D=34
Mounting, manual transmission	2.5 TDI	AJT	<b>F8-7041</b>		d=13; L=62; D=34
Mounting, manual transmission	1.9 D, 1.9 TD, 2.0, 2.4 D	ch.70-P-004343→; ch.→70-T-199999;  5-speed	<b>F8-7047</b>		
Mounting, manual transmission	2.4 D Syncro	Transmission Nr: →11086;  5-speed	<b>F8-7047</b>		
Mounting, manual transmission	2.5	ch.70-P-004343→; ch.→70-T-199999;  AAF, ACU;  5-speed	<b>F8-7047</b>		
Engine Mounting	1.9 TD, 2.0, 2.5 TDI	ch.70-T-200001→; 01/1996 →;	<b>F8-7748</b>		
Engine Mounting	2.4 D, 2.4 D Syncro	ch.70-T-200001→; 01/1996 →	<b>F8-7748</b>		
Engine Mounting	2.4 D, 2.5 Syncro, 2.5 TDI		<b>F8-7748</b>		
Engine Mounting	2.5	ch.70-T-200001→; 01/1996 →;  ACU, AEN, AEU; not for  AAF;	<b>F8-7748</b>		
Engine Mounting	2.5	ch.70-T-200001→; 01/1996 →;  ACU, AEN; not for  AAF, AEU;	<b>F8-7748</b>		
Engine Mounting	2.5	ch.70-X-000001→; 05/1998 →;  AET;	<b>F8-7748</b>		
Engine Mounting	2.5	APL, AVT;	<b>F8-7748</b>		
Engine Mounting	2.5 Syncro	ch.70-T-200001→; 01/1996 →;  ACU; not for  AAF, AEN, AEU	<b>F8-7748</b>		
Engine Mounting	2.5, 2.8 VR6		<b>F8-7748</b>		
Engine Mounting	1.9 TD, 2.0	ch.70-T-200001→; 01/1996 →;	<b>F8-7749</b>		
Engine Mounting	2.5	ch.→70-W-200000;  AET; not for  APL, AVT;	<b>F8-7749</b>		
Engine Mounting	2.5	ch.70-T-200001→; 01/1996 →;  AEU; not for  AAF, ACU, AEN;	<b>F8-7749</b>		
Engine Mounting	2.5 Syncro	ch.70-T-200001→; 01/1996 →;  AEU; not for  AAF, ACU, AEN	<b>F8-7749</b>		
Engine Mounting	2.5 TDI	ch.→70-T-199999;  ACV; not for  AUF, AYC	<b>F8-7749</b>		
Engine Mounting	2.5 TDI	ch.70-T-200001→; 01/1996 →;  ACV, AYC; not for  AUF;	<b>F8-7749</b>		
Engine Mounting	2.5 TDI, 2.5 TDI Syncro		<b>F8-7749</b>		
Engine Mounting	2.8 VR6		<b>F8-7749</b>		
Bellow, steering	1.9 D, 1.9 TD, 2.0, 2.4 D, 2.4 D Syncro, 2.5, 2.5 Syncro, 2.5 TDI, 2.5 TDI Syncro, 2.8 VR6	with clamps	<b>LM-10015S</b>		d1=25; d2=46; L [mm]=120
Bellow, steering	1.9 D, 1.9 TD, 2.0, 2.4 D, 2.4 D Syncro, 2.5, 2.5 Syncro, 2.5 TDI, 2.5 TDI Syncro, 2.8 VR6	with clamps	<b>LM-10017S</b>		d1=25; d2=54; L [mm]=126

<b>F5-1007</b>	<b>F8-7041</b>	<b>F8-7047</b>	<b>F8-7748</b>	<b>F8-7749</b>	<b>LM-10015S</b>	<b>LM-10017S</b>
Ref.Nr.: 028903119AQ	Ref.Nr.: 701399661	Ref.Nr.: 701399201AG	Ref.Nr.: 7D0199132D	Ref.Nr.: 7D0199132C	Ref.Nr.: 701419831	Ref.Nr.: 701419831

Article Description



Article Nr.

Fitting Position



**TRANSPORTER Mk IV Platform/Chassis (70XD)**

07/1990 → 04/2003

Alternator Freewheel Clutch	2.0, 2.4 D, 2.4 D Syncro		<b>F5-1007</b>		
Alternator Freewheel Clutch	2.5 TDI, 2.5 TDI Syncro		<b>F5-1031</b>		
Control Arm-/Trailing Arm Bush	1.9 D, 1.9 TD, 2.0, 2.4 D, 2.4 D Syncro, 2.5, 2.5 Syncro, 2.5 TDI		<b>F7-2001</b>		H=60; d=12; D1=35; D2=38
Control Arm-/Trailing Arm Bush	1.9 D, 1.9 TD, 2.0, 2.4 D, 2.4 D Syncro, 2.5, 2.5 Syncro, 2.5 TDI	ch.→70-T-199999	<b>F7-2002</b>		H=60.2; d=14.2; D1=35.5; D2=38
Holder, exhaust system	1.9 D, 1.9 TD, 2.0, 2.4 D, 2.4 D Syncro, 2.5, 2.5 Syncro, 2.5 TDI		<b>F8-4025</b>		H=65; T [mm]=86; W=35
Clamp, silencer	1.9 D, 1.9 TD, 2.0, 2.4 D, 2.4 D Syncro, 2.5, 2.5 Syncro, 2.5 TDI	ch.→70-T-199999	<b>F8-4027</b>		H=17; W=53, 61
Control Arm-/Trailing Arm Bush	1.9 D, 1.9 TD, 2.0, 2.4 D, 2.4 D Syncro, 2.5, 2.5 Syncro, 2.5 TDI		<b>F8-4037</b>		H=60; d=12; D1=39; D2=40
Control Arm-/Trailing Arm Bush	1.9 D, 1.9 TD, 2.0, 2.4 D, 2.4 D Syncro, 2.5, 2.5 Syncro, 2.5 TDI	ch.70-M-083343→	<b>F8-4038</b>		H1=45; H2=60.2; d=14.2; D1=28.8; D2=45.5
Control Arm-/Trailing Arm Bush	1.9 D	ch.70-V-000001→	<b>F8-4039</b>		H=60; d=14.1; D1=40; D2=51.7
Control Arm-/Trailing Arm Bush	1.9 TD, 2.0, 2.4 D, 2.4 D Syncro, 2.5, 2.5 Syncro, 2.5 TDI	ch.70-V-000001→; 05/1996 →	<b>F8-4039</b>		H=60; d=14.1; D1=40; D2=51.7
Control Arm-/Trailing Arm Bush	2.4 D, 2.5, 2.5 Syncro		<b>F8-4039</b>		H=60; d=14.1; D1=40; D2=51.7
Bump Stop, stub axle	1.9 D, 1.9 TD, 2.0, 2.4 D, 2.4 D Syncro, 2.5, 2.5 Syncro, 2.5 TDI		<b>F8-4040</b>		H=48; D1=18; D2=54
Stabiliser Mounting	1.9 D, 1.9 TD, 2.0, 2.4 D, 2.4 D Syncro, 2.5, 2.5 Syncro	ch.→70-T-199999	<b>F8-4055</b>		H=35; d=22.5; L=30
Bellow, steering	1.9 D, 1.9 TD, 2.0, 2.4 D, 2.4 D Syncro, 2.5, 2.5 Syncro, 2.5 TDI		<b>F8-4072</b>		D1/D2=außen: Ø36/Ø55; D1=36; D2=55
Control Arm-/Trailing Arm Bush	1.8, 1.9 D, 1.9 TD, 2.0, 2.4 D, 2.4 D Syncro, 2.5, 2.5 Syncro, 2.5 TDI, 2.5 TDI Syncro, 2.8, 2.8 VR6		<b>F8-4082</b>		H=75; d=12; D1=48; D2=54
Control Arm-/Trailing Arm Bush	2.5 Syncro	AAF, ACU, AEU	<b>F8-4082</b>		H=75; d=12; D1=48; D2=54
Control Arm-/Trailing Arm Bush	1.9 D, 1.9 TD, 2.0, 2.4 D, 2.4 D Syncro, 2.5, 2.5 Syncro, 2.5 TDI		<b>F8-4083</b>		H=75; d=14; D1=48; D2=55
Belt Pulley, crankshaft	2.4 D, 2.4 D Syncro, 2.5, 2.5 Syncro, 2.5 TDI		<b>F8-5202</b>		H=57.6; d=18.55; D=188
Belt Pulley, crankshaft	2.4 D, 2.4 D Syncro, 2.5, 2.5 Syncro, 2.5 TDI	with fastening material	<b>F8-5202K1</b>		H=57.6; d=18.55; D=188
Engine Mounting	1.8, 1.9 D, 1.9 TD, 2.0, 2.4 D, 2.5, 2.5 TDI	4-speed	<b>F8-5531</b>		
Belt Pulley, crankshaft	1.9 D	ch.70-P-046679, 70-P-085001→; ch.→70-T-1999000; Number of Ribs: 5; Parameter: 6PK;	<b>F8-5649</b>		H=31.5; d=30.02; Mounting points diam.[mm]=8.5; D1=161.5; D2=160.5
Belt Pulley, crankshaft	1.9 TD	ch.70-P-046679, 70-P-085001→; ch.→70-3-250000, 70-4-099000; Number of Ribs: 5; Parameter: 6PK;	<b>F8-5649</b>		H=31.5; d=30.02; Mounting points diam.[mm]=8.5; D1=161.5; D2=160.5
Supporting Ring, suspension strut bearing	1.8, 1.9 D, 1.9 TD, 2.0, 2.4 D, 2.4 D Syncro, 2.5, 2.5 Syncro, 2.5 TDI, 2.5 TDI Syncro, 2.8, 2.8 VR6		<b>F8-6261</b>		

<b>F5-1007</b>	<b>F5-1031</b>	<b>F7-2001</b>	<b>F7-2002</b>	<b>F8-4025</b>	<b>F8-4027</b>	<b>F8-4037</b>
Ref.Nr.: 028903119AQ	Ref.Nr.: 021903119H	Ref.Nr.: 701407087	Ref.Nr.: 701407183	Ref.Nr.: 1H0253144	Ref.Nr.: 171253147A	Ref.Nr.: 701407077
<b>F8-4038</b>	<b>F8-4039</b>	<b>F8-4040</b>	<b>F8-4055</b>	<b>F8-4072</b>	<b>F8-4082</b>	<b>F8-4083</b>
Ref.Nr.: 701407140B	Ref.Nr.: 701407183C	Ref.Nr.: 701407303	Ref.Nr.: 701411041	Ref.Nr.: 701419831	Ref.Nr.: 251501131A	Ref.Nr.: 701501131
<b>F8-5202</b>	<b>F8-5202K1</b>	<b>F8-5531</b>	<b>F8-5649</b>	<b>F8-6261</b>	<b>F8-6708</b>	
Ref.Nr.: 074105251T	Ref.Nr.: 74105251N	Ref.Nr.: 701399201AE	Ref.Nr.: 028105243T	Ref.Nr.: 411513121	Ref.Nr.: 7D1411041	

**Article Description****Article Nr.****Fitting Position**

<b>TRANSPORTER Mk IV Platform/Chassis (70XD)</b>				<b>07/1990 → 04/2003</b>	
Stabiliser Mounting	1.9 TD, 2.4 D, 2.4 D Syncro, 2.5, 2.5 Syncro, 2.5 TDI, 2.5 TDI Syncro, 2.8		<b>F8-6708</b>		d=23
Mounting, manual transmission	1.9 TD, 2.0, 2.4 D	ch.70-T-200001→; 01/1996 →	<b>F8-7041</b>		d=13; L=62; D=34
Mounting, manual transmission	2.4 D Syncro	05/1996 →; Transmission Nr: 12086→;  5-speed	<b>F8-7041</b>		d=13; L=62; D=34
Mounting, manual transmission	2.5		<b>F8-7041</b>		d=13; L=62; D=34
Mounting, manual transmission	2.5	ch.70-T-200001→; 01/1996 →;  ACU, AEU	<b>F8-7041</b>		d=13; L=62; D=34
Mounting, manual transmission	2.5 Syncro	05/1996 →;  ACU, AEU; Transmission Nr: 12086→;  5-speed	<b>F8-7041</b>		d=13; L=62; D=34
Mounting, manual transmission	2.5 Syncro, 2.5 TDI Syncro	Transmission Nr: 12086→;  5-speed	<b>F8-7041</b>		d=13; L=62; D=34
Mounting, manual transmission	2.5 TDI	ACV, AUF	<b>F8-7041</b>		d=13; L=62; D=34
Mounting, manual transmission	2.5 TDI	AJT	<b>F8-7041</b>		d=13; L=62; D=34
Mounting, manual transmission	1.9 D, 1.9 TD, 2.0, 2.4 D	ch.70-P-004343→; ch.→70-T-199999;  5-speed	<b>F8-7047</b>		
Mounting, manual transmission	2.4 D Syncro	Transmission Nr: →11086;  5-speed	<b>F8-7047</b>		
Mounting, manual transmission	2.5	ch.70-P-004343→; ch.→70-T-199999;  AAF, ACU;  5-speed	<b>F8-7047</b>		
Engine Mounting	1.9 TD, 2.0, 2.5 TDI	ch.70-T-200001→; 01/1996 →;	<b>F8-7748</b>		
Engine Mounting	2.4 D, 2.4 D Syncro	ch.70-T-200001→; 01/1996 →	<b>F8-7748</b>		
Engine Mounting	2.4 D, 2.5 Syncro, 2.5 TDI		<b>F8-7748</b>		
Engine Mounting	2.5	ch.70-T-200001→; 01/1996 →;  ACU, AEN, AEU; not for  AAF;	<b>F8-7748</b>		
Engine Mounting	2.5	ch.70-T-200001→; 01/1996 →;  ACU, AEN; not for  AAF, AEU;	<b>F8-7748</b>		
Engine Mounting	2.5	ch.70-X-000001→; 05/1998 →;  AET;	<b>F8-7748</b>		
Engine Mounting	2.5		<b>F8-7748</b>		
Engine Mounting	2.5	APL, AVT;	<b>F8-7748</b>		
Engine Mounting	2.5 Syncro	ch.70-T-200001→; 01/1996 →;  ACU; not for  AAF, AEN, AEU	<b>F8-7748</b>		
Engine Mounting	1.9 TD, 2.0	ch.70-T-200001→; 01/1996 →;	<b>F8-7749</b>		
Engine Mounting	2.5	ch.→70-W-200000;  AET; not for  APL, AVT;	<b>F8-7749</b>		
Engine Mounting	2.5	ch.70-T-200001→; 01/1996 →;  AEU; not for  AAF, ACU, AEN;	<b>F8-7749</b>		
Engine Mounting	2.5 Syncro	ch.70-T-200001→; 01/1996 →;  AEU; not for  AAF, ACU, AEN	<b>F8-7749</b>		
Engine Mounting	2.5 TDI	ch.→70-T-199999;  ACV; not for  AUF, AYC	<b>F8-7749</b>		
Engine Mounting	2.5 TDI	ch.70-T-200001→; 01/1996 →;  ACV, AYC; not for  AUF;	<b>F8-7749</b>		



**F8-6708**  
Ref.Nr.: 7D1411041



**F8-7041**  
Ref.Nr.: 701399661



**F8-7047**  
Ref.Nr.: 701399201AG



**F8-7748**  
Ref.Nr.: 7D0199132D



**F8-7749**  
Ref.Nr.: 7D0199132C

Article Description



Article Nr.

Fitting Position



<b>TRANSPORTER Mk IV Platform/Chassis (70XD)</b>			<b>07/1990 → 04/2003</b>	
Engine Mounting	2.5 TDI Syncro		<b>F8-7749</b>	
Bellow, steering	1.8, 1.9 D, 1.9 TD, 2.0, 2.4 D, 2.4 D Syncro, 2.5, 2.5 Syncro, 2.5 TDI, 2.5 TDI Syncro, 2.8, 2.8 VR6	with clamps	<b>LM-10015S</b>	d1=25; d2=46; L [mm]=120
Bellow, steering	1.8, 1.9 D, 1.9 TD, 2.0, 2.4 D, 2.4 D Syncro, 2.5, 2.5 Syncro, 2.5 TDI, 2.5 TDI Syncro, 2.8, 2.8 VR6	with clamps	<b>LM-10017S</b>	d1=25; d2=54; L [mm]=126
<b>MULTIVAN Mk V (7HM, 7HN, 7HF, 7EF, 7EM, 7EN)</b>			<b>04/2003 → 11/2009</b>	
Alternator Freewheel Clutch	1.9 TDI, 2.0, 3.2 V6, 3.2 V6 4motion		<b>F5-1004</b>	
Alternator Freewheel Clutch	2.0 BiTDI, 2.0 BiTDI 4motion, 2.0 TDI, 2.0 TDI 4motion		<b>F5-1085</b>	
Alternator Freewheel Clutch	2.5 TDI, 2.5 TDI 4motion		<b>F5-1103</b>	
Control Arm-/Trailing Arm Bush	1.9 TDI, 2.0, 2.5 TDI, 3.2 V6		<b>F8-5302</b>	
Control Arm-/Trailing Arm Bush	All Models		<b>F8-5303</b>	H=60.3; d=14.1; D1=51.5; D2=40.3
Belt Pulley, crankshaft	2.0		<b>F8-5650</b>	
Belt Pulley, crankshaft	1.9 TDI	ch.→7H-5-075000, 7J-5-022000; Number of Ribs: 5; Parameter: 6PK	<b>F8-6392</b>	H=47; d=30; D=143
Belt Pulley, crankshaft	1.9 TDI	Number of Ribs: 5; Parameter: 6PK	<b>F8-6392</b>	H=47; d=30; D=143
Belt Pulley, crankshaft	1.9 TDI	ch.7H-5-075001, 7J-5-022001→; Number of Ribs: 5; Parameter: 6PK	<b>F8-6396</b>	H=41.6; d=30; Mounting points diam.[mm]=7, 8.6; D=139.7
Belt Pulley, crankshaft	1.9 TDI	Number of Ribs: 5; Parameter: 6PK	<b>F8-6396</b>	H=41.6; d=30; Mounting points diam.[mm]=7, 8.6; D=139.7
Top Strut Mounting	All Models		<b>F8-6540</b>	
Belt Pulley, crankshaft	2.0 BiTDI, 2.0 BiTDI 4motion, 2.0 TDI, 2.0 TDI 4motion	Number of Ribs: 5; Parameter: 6PK	<b>F8-6572</b>	
Belt Pulley, crankshaft	2.0 TDI 4motion	CCHA; Number of Ribs: 5; Parameter: 6PK	<b>F8-6572</b>	
Stabiliser Mounting	All Models		<b>F8-7387</b>	H1=42; H2=35; d=22; W=48
Anti-Friction Bearing	All Models		<b>F8-7494</b>	
Top Strut Mounting	All Models		<b>F8-7575</b>	
Control Arm-/Trailing Arm Bush	2.0 TDI, 2.0 TSI, 2.0 TSI 4motion	[kg]: 1680; for OE: 2MR;	<b>F8-7745</b>	
Belt Pulley, crankshaft	2.0 TSI, 2.0 TSI 4motion	Number of Ribs: 5; Parameter: 6PK	<b>F8-7880</b>	D=143
Stabiliser Mounting	1.9 TDI, 2.0, 2.0 BiTDI, 2.0 BiTDI 4motion, 2.0 TDI, 2.0 TDI 4motion, 2.0 TSI, 2.0 TSI 4motion, 2.5 TDI, 2.5 TDI 4motion, 3.2 V6, 3.2 V6 4motion	Stabi. Diam. [mm]= 25	<b>F8-7904</b>	d=24
Control Arm-/Trailing Arm Bush	1.9 TDI, 2.0, 2.5 TDI, 3.2 V6	not for  [kg]: 3200; not for PR: 0WR	<b>F8-7910</b>	
Control Arm-/Trailing Arm Bush	2.5 TDI 4motion	AXD; not for  [kg]: 3200; not for PR: 0WR	<b>F8-7910</b>	
Control Arm-/Trailing Arm Bush	2.5 TDI 4motion	AXE; not for  [kg]: 3200; not for PR: 0WR	<b>F8-7910</b>	

<b>F5-1004</b>	<b>F5-1085</b>	<b>F5-1103</b>	<b>F8-5302</b>	<b>F8-5303</b>	<b>F8-5650</b>	<b>F8-6392</b>
Ref.Nr.: 038903119T	Ref.Nr.: 045903119A	Ref.Nr.: 070903201C	Ref.Nr.: 7H0407182A	Ref.Nr.: 7H0407183	Ref.Nr.: 06A105243E	Ref.Nr.: 038105243
<b>F8-6396</b>	<b>F8-6540</b>	<b>F8-6572</b>	<b>F8-7387</b>	<b>F8-7494</b>	<b>F8-7575</b>	<b>F8-7745</b>
Ref.Nr.: 03G105243	Ref.Nr.: 7E0 412 331	Ref.Nr.: 038105243L	Ref.Nr.: 7H5411313A	Ref.Nr.: 7E0412249	Ref.Nr.: 7E0412331	Ref.Nr.: 7H0407182
<b>F8-7749</b>	<b>F8-7880</b>	<b>F8-7904</b>	<b>F8-7910</b>	<b>LM-10015S</b>	<b>LM-10017S</b>	
Ref.Nr.: 7D0199132C	Ref.Nr.: 06H105243F	Ref.Nr.: 7H5411313B	Ref.Nr.: 7H0501131A	Ref.Nr.: 701419831	Ref.Nr.: 701419831	

**Article Description****Article Nr.****Fitting Position**

<b>MULTIVAN Mk V (7HM, 7HN, 7HF, 7EF, 7EM, 7EN)</b>			<b>04/2003 → 11/2009</b>	
Control Arm-/Trailing Arm Bush	3.2 V6, 3.2 V6 4motion	BKK; not for  [kg]: 3200; not for PR: 0WR	<b>F8-7910</b>	
Mounting, manual transmission	All Models		<b>F8-7911</b>	
Engine Mounting	1.9 TDI		<b>F8-7967</b>	
Engine Mounting	2.0	ch.→7H-A-002000	<b>F8-7967</b>	
Engine Mounting	1.9 TDI, 2.0, 2.0 BitDI, 2.0 TDI, 2.0 TSI		<b>F8-7968</b>	
Engine Mounting	2.5 TDI	6-speed	<b>F8-7968</b>	
Engine Mounting	1.9 TDI, 2.0		<b>F8-7983</b>	
Engine Mounting	2.0 BitDI, 2.0 BitDI 4motion, 2.0 TDI, 2.0 TDI 4motion	5-speed	<b>F8-7983</b>	
Mounting, manual transmission	1.9 TDI, 2.0		<b>F8-7984</b>	
Mounting, manual transmission	2.0 BitDI, 2.0 BitDI 4motion, 2.0 TDI, 2.0 TDI 4motion, 2.0 TSI, 2.0 TSI 4motion	5-speed	<b>F8-7984</b>	
Bearing Bush, stabiliser	All Models		<b>F8-8216</b>	H1=42; H2=35; d=22; W=48
Stabiliser Mounting	1.9 TDI, 2.0, 2.5 TDI, 3.2 V6		<b>G7-1001</b>	d=21; W=52
<b>TRANSPORTER / CARAVELLE Mk V Bus (7HB, 7HJ, 7EB, 7EJ, 7EF, 7)</b>			<b>04/2003 → 11/2009</b>	
Alternator Freewheel Clutch	1.9 TDI, 2.0, 3.2 4motion, 3.2 V6, 3.2 V6 4motion		<b>F5-1004</b>	
Alternator Freewheel Clutch	2.0 BitDI, 2.0 BitDI 4motion, 2.0 TDI, 2.0 TDI 4motion		<b>F5-1085</b>	
Alternator Freewheel Clutch	2.5 TDI, 2.5 TDI 4motion		<b>F5-1103</b>	
Control Arm-/Trailing Arm Bush	1.9 TDI, 2.0, 2.0 TDI, 2.0 TSI, 2.0 TSI 4motion, 2.5 TDI, 2.5 TDI 4motion, 3.2 4motion, 3.2 V6, 3.2 V6 4motion		<b>F8-5303</b>	H=60.3; d=14.1; D1=51.5; D2=40.3
Belt Pulley, crankshaft	2.0		<b>F8-5650</b>	
Belt Pulley, crankshaft	1.9 TDI	ch.→7H-5-075000, 7J-5-022000; Number of Ribs: 5; Parameter: 6PK	<b>F8-6392</b>	H=47; d=30; D=143
Belt Pulley, crankshaft	1.9 TDI	Number of Ribs: 5; Parameter: 6PK	<b>F8-6392</b>	H=47; d=30; D=143
Belt Pulley, crankshaft	1.9 TDI	ch.7H-5-075001, 7J-5-022001→; Number of Ribs: 5; Parameter: 6PK	<b>F8-6396</b>	H=41.6; d=30; Mounting points diam.[mm]=7, 8.6; D=139.7
Belt Pulley, crankshaft	1.9 TDI	Number of Ribs: 5; Parameter: 6PK	<b>F8-6396</b>	H=41.6; d=30; Mounting points diam.[mm]=7, 8.6; D=139.7
Top Strut Mounting	All Models		<b>F8-6540</b>	
Belt Pulley, crankshaft	2.0 BitDI, 2.0 BitDI 4motion, 2.0 TDI	Number of Ribs: 5; Parameter: 6PK	<b>F8-6572</b>	
Belt Pulley, crankshaft	2.0 TDI 4motion	CCHA; Number of Ribs: 5; Parameter: 6PK	<b>F8-6572</b>	
Belt Pulley, crankshaft	2.0 TDI 4motion	CCHB; Number of Ribs: 5; Parameter: 6PK	<b>F8-6572</b>	
Stabiliser Mounting	All Models		<b>F8-7387</b>	H1=42; H2=35; d=22; W=48
Anti-Friction Bearing	All Models		<b>F8-7494</b>	
Top Strut Mounting	All Models		<b>F8-7575</b>	

<b>F5-1004</b>	<b>F5-1085</b>	<b>F5-1103</b>	<b>F8-5303</b>	<b>F8-5650</b>	<b>F8-6392</b>	<b>F8-6396</b>
Ref.Nr.: 038903119T	Ref.Nr.: 045903119A	Ref.Nr.: 070903201C	Ref.Nr.: 7H0407183	Ref.Nr.: 06A105243E	Ref.Nr.: 038105243	Ref.Nr.: 03G105243
<b>F8-6540</b>	<b>F8-6572</b>	<b>F8-7387</b>	<b>F8-7494</b>	<b>F8-7575</b>	<b>F8-7745</b>	<b>F8-7910</b>
Ref.Nr.: 7E0 412 331	Ref.Nr.: 038105243L	Ref.Nr.: 7H5411313A	Ref.Nr.: 7E0412249	Ref.Nr.: 7E0412331	Ref.Nr.: 7H0407182	Ref.Nr.: 7H0501131A
<b>F8-7911</b>	<b>F8-7967</b>	<b>F8-7968</b>	<b>F8-7983</b>	<b>F8-7984</b>	<b>F8-8216</b>	<b>G7-1001</b>
Ref.Nr.: 7H0501132A	Ref.Nr.: 7H0199256F	Ref.Nr.: 7H0199849BB	Ref.Nr.: 7H0199848G	Ref.Nr.: 7H0399151G	Ref.Nr.: 7H5411313A	Ref.Nr.: 7H0411313

Article Description



Article Nr.

Fitting Position



**TRANSPORTER / CARAVELLE Mk V Bus (7HB, 7HJ, 7EB, 7EJ, 7EF, 7** **04/2003 → 11/2009**

Control Arm-/Trailing Arm Bush	1.9 TDI, 2.0, 2.5 TDI, 2.5 TDI 4motion, 3.2 4motion, 3.2 V6, 3.2 V6 4motion	[kg]: 3200	<b>F8-7745</b>	⊕ ⊕	
Control Arm-/Trailing Arm Bush	2.0 TDI, 2.0 TSI, 2.0 TSI 4motion	[kg]: 1680; for OE: 2MQ, 2MR;	<b>F8-7745</b>	⊕ ⊕	
Control Arm-/Trailing Arm Bush	2.0 TDI, 2.0 TSI, 2.0 TSI 4motion	[kg]: 1710; for OE: 2MT, 2MU;	<b>F8-7745</b>	⊕ ⊕	
Belt Pulley, crankshaft	2.0 TSI	Number of Ribs: 5; Parameter: 6PK	<b>F8-7880</b>		D=143
Stabiliser Mounting	1.9 TDI, 2.0, 2.0 BiTDI, 2.0 BiTDI 4motion, 2.0 TDI, 2.0 TDI 4motion, 2.0 TSI, 2.0 TSI 4motion, 2.5 TDI, 2.5 TDI 4motion, 3.2 V6, 3.2 V6 4motion	Stabi. Diam. [mm]= 25	<b>F8-7904</b>	⊕ ⊕	d=24
Control Arm-/Trailing Arm Bush	1.9 TDI, 2.0, 2.5 TDI, 2.5 TDI 4motion, 3.2 4motion, 3.2 V6	not for  [kg]: 3200; not for PR: 0WR	<b>F8-7910</b>	⊕ ⊕	
Control Arm-/Trailing Arm Bush	3.2 V6, 3.2 V6 4motion	BKK; not for  [kg]: 3200; not for PR: 0WR	<b>F8-7910</b>	⊕ ⊕	
Mounting, manual transmission	All Models		<b>F8-7911</b>	⊕ ⊕	
Engine Mounting	1.9 TDI		<b>F8-7967</b>	⊕	
Engine Mounting	2.0	ch.→7H-A-002000	<b>F8-7967</b>	⊕	
Engine Mounting	1.9 TDI, 2.0, 2.0 BiTDI, 2.0 TDI, 2.0 TSI		<b>F8-7968</b>		
Engine Mounting	2.5 TDI	6-speed	<b>F8-7968</b>		
Engine Mounting	1.9 TDI, 2.0		<b>F8-7983</b>		
Engine Mounting	2.0 BiTDI, 2.0 BiTDI 4motion, 2.0 TDI, 2.0 TDI 4motion	5-speed	<b>F8-7983</b>		
Mounting, manual transmission	1.9 TDI, 2.0		<b>F8-7984</b>	⊕	
Mounting, manual transmission	2.0 BiTDI, 2.0 BiTDI 4motion, 2.0 TDI, 2.0 TDI 4motion	5-speed	<b>F8-7984</b>	⊕	
Bearing Bush, stabiliser	All Models		<b>F8-8216</b>	⊕ ⊕	H1=42; H2=35; d=22; W=48

**TRANSPORTER Mk V Box (7HA, 7HH, 7EA, 7EH)** **04/2003 → 11/2009**

Alternator Freewheel Clutch	1.9 TDI, 2.0, 3.2 4motion, 3.2 V6		<b>F5-1004</b>		
Alternator Freewheel Clutch	2.0 BiTDI, 2.0 BiTDI 4motion, 2.0 TDI, 2.0 TDI 4motion		<b>F5-1085</b>		
Alternator Freewheel Clutch	2.5 TDI, 2.5 TDI 4motion		<b>F5-1103</b>		
Control Arm-/Trailing Arm Bush	1.9 TDI, 2.0, 2.0 TDI, 2.0 TDI 4motion, 2.0 TSI, 2.0 TSI 4motion, 2.5 TDI, 2.5 TDI 4motion, 3.2 4motion, 3.2 V6		<b>F8-5303</b>	⊕ ⊕ ⊕ ↓	H=60.3; d=14.1; D1=51.5; D2=40.3
Belt Pulley, crankshaft	2.0		<b>F8-5650</b>		
Belt Pulley, crankshaft	1.9 TDI	ch.→7H-5-075000, 7J-5-022000; Number of Ribs: 5; Parameter: 6PK	<b>F8-6392</b>		H=47; d=30; D=143
Belt Pulley, crankshaft	1.9 TDI	Number of Ribs: 5; Parameter: 6PK	<b>F8-6392</b>		H=47; d=30; D=143
Belt Pulley, crankshaft	1.9 TDI	ch.7H-5-075001, 7J-5-022001→; Number of Ribs: 5; Parameter: 6PK	<b>F8-6396</b>		H=41.6; d=30; Mounting points diam.[mm]=7, 8.6; D=139.7
Belt Pulley, crankshaft	1.9 TDI	Number of Ribs: 5; Parameter: 6PK	<b>F8-6396</b>		H=41.6; d=30; Mounting points diam.[mm]=7, 8.6; D=139.7
Top Strut Mounting	All Models		<b>F8-6540</b>	⊕ ⊕	

<b>F5-1004</b>	<b>F5-1085</b>	<b>F5-1103</b>	<b>F8-5303</b>	<b>F8-5650</b>	<b>F8-6392</b>	<b>F8-6396</b>
Ref.Nr.: 038903119T	Ref.Nr.: 045903119A	Ref.Nr.: 070903201C	Ref.Nr.: 7H0407183	Ref.Nr.: 06A105243E	Ref.Nr.: 038105243	Ref.Nr.: 03G105243
<b>F8-6540</b>	<b>F8-6572</b>	<b>F8-7745</b>	<b>F8-7880</b>	<b>F8-7904</b>	<b>F8-7910</b>	<b>F8-7911</b>
Ref.Nr.: 7E0 412 331	Ref.Nr.: 038105243L	Ref.Nr.: 7H0407182	Ref.Nr.: 06H105243F	Ref.Nr.: 7H5411313B	Ref.Nr.: 7H0501131A	Ref.Nr.: 7H0501132A
<b>F8-7967</b>	<b>F8-7968</b>	<b>F8-7983</b>	<b>F8-7984</b>	<b>F8-8216</b>		
Ref.Nr.: 7H0199256F	Ref.Nr.: 7H0199849BB	Ref.Nr.: 7H0199848G	Ref.Nr.: 7H0399151G	Ref.Nr.: 7H5411313A		

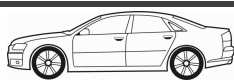
**Article Description****Article Nr.****Fitting Position****TRANSPORTER Mk V Box (7HA, 7HH, 7EA, 7EH) 04/2003 → 11/2009**

Belt Pulley, crankshaft	2.0 BiTDI, 2.0 BiTDI 4motion, 2.0 TDI, 2.0 TDI 4motion	Number of Ribs: 5; Parameter: 6PK	<b>F8-6572</b>		
Belt Pulley, crankshaft	2.0 TDI 4motion	CAAE, CCHB; Number of Ribs: 5; Parameter: 6PK	<b>F8-6572</b>		
Stabiliser Mounting	All Models		<b>F8-7387</b>		H1=42; H2=35; d=22; W=48
Anti-Friction Bearing	All Models		<b>F8-7494</b>		
Top Strut Mounting	All Models		<b>F8-7575</b>		
Control Arm-/Trailing Arm Bush	1.9 TDI, 2.0, 2.5 TDI, 2.5 TDI 4motion, 3.2 4motion, 3.2 V6	[kg]: 3200	<b>F8-7745</b>		
Control Arm-/Trailing Arm Bush	2.0 TDI 4motion	[kg]: 1680; for OE: 2MR;	<b>F8-7745</b>		
Control Arm-/Trailing Arm Bush	2.0 TDI, 2.0 TSI, 2.0 TSI 4motion	[kg]: 1680; for OE: 2MQ, 2MR;	<b>F8-7745</b>		
Control Arm-/Trailing Arm Bush	2.0 TDI, 2.0 TSI, 2.0 TSI 4motion	[kg]: 1710; for OE: 2MT, 2MU;	<b>F8-7745</b>		
Belt Pulley, crankshaft	2.0 TSI, 2.0 TSI 4motion	Number of Ribs: 5; Parameter: 6PK	<b>F8-7880</b>		D=143
Stabiliser Mounting	1.9 TDI, 2.0, 2.0 BiTDI, 2.0 BiTDI 4motion, 2.0 TDI, 2.0 TDI 4motion, 2.0 TSI, 2.0 TSI 4motion, 2.5 TDI, 2.5 TDI 4motion, 3.2 4motion, 3.2 V6	Stabi. Diam. [mm]= 25	<b>F8-7904</b>		d=24
Control Arm-/Trailing Arm Bush	1.9 TDI, 2.0, 2.5 TDI, 2.5 TDI 4motion, 3.2 V6	not for  [kg]: 3200; not for PR: 0WR	<b>F8-7910</b>		
Control Arm-/Trailing Arm Bush	3.2 4motion, 3.2 V6	BKK; not for  [kg]: 3200; not for PR: 0WR	<b>F8-7910</b>		
Mounting, manual transmission	All Models		<b>F8-7911</b>		
Engine Mounting	1.9 TDI		<b>F8-7967</b>		
Engine Mounting	2.0	ch.→7H-A-002000	<b>F8-7967</b>		
Engine Mounting	1.9 TDI, 2.0, 2.0 BiTDI, 2.0 TDI, 2.0 TSI		<b>F8-7968</b>		
Engine Mounting	2.5 TDI	6-speed	<b>F8-7968</b>		
Engine Mounting	1.9 TDI, 2.0		<b>F8-7983</b>		
Engine Mounting	2.0 BiTDI, 2.0 BiTDI 4motion, 2.0 TDI, 2.0 TDI 4motion	5-speed	<b>F8-7983</b>		
Mounting, manual transmission	1.9 TDI, 2.0		<b>F8-7984</b>		
Mounting, manual transmission	2.0 BiTDI, 2.0 BiTDI 4motion, 2.0 TDI, 2.0 TDI 4motion	5-speed	<b>F8-7984</b>		
Bearing Bush, stabiliser	All Models		<b>F8-8216</b>		H1=42; H2=35; d=22; W=48

**TRANSPORTER Mk V Platform/Chassis (7JD, 7JE, 7JL, 7JY, 7JZ) 04/2003 → 11/2009**

Alternator Freewheel Clutch	1.9 TDI, 2.0, 3.2 V6		<b>F5-1004</b>		
Alternator Freewheel Clutch	2.0 BiTDI, 2.0 BiTDI 4motion, 2.0 TDI, 2.0 TDI 4motion		<b>F5-1085</b>		
Alternator Freewheel Clutch	2.5 TDI, 2.5 TDI 4motion		<b>F5-1103</b>		
Control Arm-/Trailing Arm Bush	1.9 TDI, 2.0, 2.0 TDI, 2.0 TDI 4motion, 2.0 TSI, 2.5 TDI, 2.5 TDI 4motion, 3.2 V6		<b>F8-5303</b>		H=60.3; d=14.1; D1=51.5; D2=40.3
Belt Pulley, crankshaft	2.0		<b>F8-5650</b>		

<b>F5-1004</b>	<b>F5-1085</b>	<b>F5-1103</b>	<b>F8-5303</b>	<b>F8-5650</b>	<b>F8-6392</b>	<b>F8-6572</b>
Ref.Nr.: 038903119T	Ref.Nr.: 045903119A	Ref.Nr.: 070903201C	Ref.Nr.: 7H0407183	Ref.Nr.: 06A105243E	Ref.Nr.: 038105243	Ref.Nr.: 038105243L
<b>F8-7387</b>	<b>F8-7494</b>	<b>F8-7575</b>	<b>F8-7745</b>	<b>F8-7880</b>	<b>F8-7904</b>	<b>F8-7910</b>
Ref.Nr.: 7H5411313A	Ref.Nr.: 7E0412249	Ref.Nr.: 7E0412331	Ref.Nr.: 7H0407182	Ref.Nr.: 06H105243F	Ref.Nr.: 7H5411313B	Ref.Nr.: 7H0501131A
<b>F8-7911</b>	<b>F8-7967</b>	<b>F8-7968</b>	<b>F8-7983</b>	<b>F8-7984</b>	<b>F8-8216</b>	
Ref.Nr.: 7H0501132A	Ref.Nr.: 7H0199256F	Ref.Nr.: 7H0199849BB	Ref.Nr.: 7H0199848G	Ref.Nr.: 7H0399151G	Ref.Nr.: 7H5411313A	

Article Description



Article Nr.

Fitting Position



<b>TRANSPORTER Mk V Platform/Chassis (7JD, 7JE, 7JL, 7JY, 7JZ)</b>				<b>04/2003 → 11/2009</b>	
Belt Pulley, crankshaft	1.9 TDI	ch.→7H-5-075000, 7J-5-022000; Number of Ribs: 5; Parameter: 6PK	<b>F8-6392</b>		H=47; d=30; D=143
Belt Pulley, crankshaft	1.9 TDI	ch.7H-5-075001, 7J-5-022001→; Number of Ribs: 5; Parameter: 6PK	<b>F8-6396</b>		H=41.6; d=30; Mounting points diam.[mm]=7, 8.6; D=139.7
Belt Pulley, crankshaft	1.9 TDI	Number of Ribs: 5; Parameter: 6PK	<b>F8-6396</b>		H=41.6; d=30; Mounting points diam.[mm]=7, 8.6; D=139.7
Top Strut Mounting	1.9 TDI, 2.0, 2.0 BiTDI, 2.0 BiTDI 4motion, 2.0 TDI, 2.0 TDI 4motion, 2.0 TSI, 2.5 TDI, 2.5 TDI 4motion, 3.2 V6		<b>F8-6540</b>		
Belt Pulley, crankshaft	2.0 BiTDI, 2.0 BiTDI 4motion, 2.0 TDI, 2.0 TDI 4motion	Number of Ribs: 5; Parameter: 6PK	<b>F8-6572</b>		
Belt Pulley, crankshaft	2.0 TDI 4motion	CAAE; Number of Ribs: 5; Parameter: 6PK	<b>F8-6572</b>		
Stabiliser Mounting	1.9 TDI, 2.0, 2.0 BiTDI, 2.0 BiTDI 4motion, 2.0 TDI, 2.0 TDI 4motion, 2.0 TSI, 2.5 TDI, 2.5 TDI 4motion, 3.2 V6		<b>F8-7387</b>		H1=42; H2=35; d=22; W=48
Anti-Friction Bearing	1.9 TDI, 2.0, 2.0 BiTDI, 2.0 BiTDI 4motion, 2.0 TDI, 2.0 TDI 4motion, 2.0 TSI, 2.5 TDI, 2.5 TDI 4motion, 3.2 V6		<b>F8-7494</b>		
Top Strut Mounting	1.9 TDI, 2.0, 2.0 BiTDI, 2.0 BiTDI 4motion, 2.0 TDI, 2.0 TDI 4motion, 2.0 TSI, 2.5 TDI, 2.5 TDI 4motion, 3.2 V6		<b>F8-7575</b>		
Control Arm-/Trailing Arm Bush	1.9 TDI, 2.0, 2.5 TDI, 2.5 TDI 4motion, 3.2 V6	[kg]: 3000;	<b>F8-7745</b>		
Control Arm-/Trailing Arm Bush	2.0 TDI, 2.0 TDI 4motion, 2.0 TSI	[kg]: 1710;	<b>F8-7745</b>		
Control Arm-/Trailing Arm Bush	2.0 TDI, 2.0 TDI 4motion, 2.0 TSI	[kg]: 1710;	<b>F8-7745</b>		
Stabiliser Mounting	1.9 TDI, 2.0, 2.0 BiTDI, 2.0 BiTDI 4motion, 2.0 TDI, 2.0 TDI 4motion, 2.0 TSI, 2.5 TDI, 2.5 TDI 4motion, 3.2 V6	Stabi. Diam. [mm]= 25	<b>F8-7904</b>		d=24
Control Arm-/Trailing Arm Bush	1.9 TDI, 2.0, 2.5 TDI, 2.5 TDI 4motion, 3.2 V6	not for  [kg]: 3200; not for PR: 0WR	<b>F8-7910</b>		
Control Arm-/Trailing Arm Bush	2.5 TDI 4motion	AXD: not for  [kg]: 3200; not for PR: 0WR	<b>F8-7910</b>		
Mounting, manual transmission	1.9 TDI, 2.0, 2.0 BiTDI, 2.0 BiTDI 4motion, 2.0 TDI, 2.0 TDI 4motion, 2.0 TSI, 2.5 TDI, 2.5 TDI 4motion, 3.2 V6		<b>F8-7911</b>		
Engine Mounting	1.9 TDI		<b>F8-7967</b>		
Engine Mounting	2.0	ch.→7H-A-002000	<b>F8-7967</b>		
Engine Mounting	1.9 TDI, 2.0, 2.0 BiTDI, 2.0 TDI, 2.0 TSI		<b>F8-7968</b>		
Engine Mounting	2.5 TDI	6-speed	<b>F8-7968</b>		
Engine Mounting	1.9 TDI, 2.0		<b>F8-7983</b>		
Engine Mounting	2.0 BiTDI, 2.0 BiTDI 4motion, 2.0 TDI, 2.0 TDI 4motion	5-speed	<b>F8-7983</b>		
Mounting, manual transmission	1.9 TDI, 2.0		<b>F8-7984</b>		





**Article Description****Article Nr.****Fitting Position**

<b>TRANSPORTER Mk V Platform/Chassis (7JD, 7JE, 7JL, 7JY, 7JZ,</b>				<b>04/2003 → 11/2009</b>	
Mounting, manual transmission	2.0 BiTDI, 2.0 BiTDI 4motion, 2.0 TDI, 2.0 TDI 4motion	5-speed	<b>F8-7984</b>		
Bearing Bush, stabiliser	1.9 TDI, 2.0, 2.0 BiTDI, 2.0 BiTDI 4motion, 2.0 TDI, 2.0 TDI 4motion, 2.0 TSI, 2.5 TDI, 2.5 TDI 4motion, 3.2 V6		<b>F8-8216</b>		H1=42; H2=35; d=22; W=48
<b>UP</b>				<b>08/2011 →</b>	
Dust Cover Kit, shock absorber	1.0, 1.0 EcoFuel	<b>ST</b>	<b>AK-735410</b>		H=210
Alternator Freewheel Clutch	1.0, 1.0 EcoFuel		<b>F5-1064</b>		
Anti-Friction Bearing	1.0, 1.0 EcoFuel		<b>F8-3039</b>		H=14; d1=14; D=45
Top Strut Mounting	1.0, 1.0 EcoFuel		<b>F8-4067</b>		H=53; d=26; D=82
Rubber Buffer, suspension	1.0, 1.0 EcoFuel		<b>F8-5381</b>		H=37; D=76
Protective Cap/Bellow, shock absorber	1.0, 1.0 EcoFuel		<b>F8-5683</b>		H=210
Top Strut Mounting	1.0, 1.0 EcoFuel		<b>F8-6280</b>		H=53; d=26; D=82
Stabiliser Mounting	1.0	Stabi. Diam. [mm]= 18	<b>F8-6462</b>		d=16
Rubber Buffer, suspension	1.0	for OE: 1JA, 1JB; , <b>ST</b>	<b>F8-6723</b>		H=124
Top Strut Mounting	1.0, 1.0 EcoFuel	for OE: 1J0412319C	<b>F8-7133</b>		
Protective Cap/Bellow, shock absorber	1.0, 1.0 EcoFuel		<b>F8-7486</b>		
Rubber Buffer, suspension	1.0, 1.0 EcoFuel	for OE: G01, G02, G06; , <b>ST</b> ; for vehicles with gas operation	<b>F8-7891</b>		H=63
Rubber Buffer, suspension	e-Up	for OE: G01, G02; , <b>ST</b>	<b>F8-7891</b>		H=63
Rubber Buffer, suspension	1.0, 1.0 EcoFuel, e-Up	for OE: G03; <b>SP</b>	<b>F8-7892</b>		H=53
Rubber Buffer, suspension	1.0, 1.0 EcoFuel, e-Up	for OE: 1JC; <b>SP</b>	<b>F8-7893</b>		H=122
Control Arm-/Trailing Arm Bush	1.0, 1.0 EcoFuel		<b>F8-7978</b>		
Control Arm-/Trailing Arm Bush	1.0		<b>G9-648</b>		H=54; d=12; D1=33; D2=36
Control Arm-/Trailing Arm Bush	1.0		<b>G9-649</b>		H1=25; H2=41; d=13; D=60
<b>VENTO (1H2)</b>				<b>11/1991 → 09/1998</b>	
Dust Cover Kit, shock absorber	1.4, 1.6, 1.8, 1.9 D, 1.9 SDI, 1.9 TD, 1.9 TDI, 2.0, 2.8 VR6		<b>AK-732516</b>		
Dust Cover Kit, shock absorber	1.4, 1.6, 1.8, 1.9 D, 1.9 SDI, 1.9 TD, 1.9 TDI, 2.0, 2.8 VR6		<b>AK-733023</b>		
Dust Cover Kit, shock absorber	1.4, 1.6, 1.8, 1.9 D, 1.9 TD, 2.0	08/1994 →	<b>AK-735031</b>		
Dust Cover Kit, shock absorber	1.6, 1.9 TDI		<b>AK-735031</b>		
Dust Cover Kit, shock absorber	All Models	<b>ST</b>	<b>AK-735410</b>		H=210
Alternator Freewheel Clutch	1.9 D, 1.9 TD, 1.9 TDI		<b>F5-1007</b>		

<b>AK-732516</b>	<b>AK-733023</b>	<b>AK-735031</b>	<b>AK-735410</b>	<b>F5-1007</b>	<b>F5-1064</b>	<b>F8-1007</b>
Ref.Nr.:	Ref.Nr.: 191412303	Ref.Nr.:	Ref.Nr.: 1J0412303	Ref.Nr.: 028903119AQ	Ref.Nr.: 03C903119D	Ref.Nr.: 191407181A
<b>F8-3039</b>	<b>F8-4067</b>	<b>F8-5381</b>	<b>F8-5683</b>	<b>F8-6280</b>	<b>F8-6462</b>	<b>F8-6723</b>
Ref.Nr.: 357412249A	Ref.Nr.: 1J0412331B	Ref.Nr.: 1J0512149B	Ref.Nr.: 357413175A	Ref.Nr.: 6R0412249	Ref.Nr.: 6Q0411314L	Ref.Nr.: 6Q0512131B
<b>F8-7133</b>	<b>F8-7486</b>	<b>F8-7891</b>	<b>F8-7892</b>	<b>F8-7893</b>	<b>F8-7978</b>	<b>F8-7984</b>
Ref.Nr.: 1J0412319C	Ref.Nr.: 1S0513425A	Ref.Nr.: 1S0412303	Ref.Nr.: 1S0412303A	Ref.Nr.: 1S0511351B	Ref.Nr.: 357407182F	Ref.Nr.: 7H0399151G

Article Description



Article Nr.

Fitting Position



VENTO (1H2)			11/1991 → 09/1998	
Control Arm-/Trailing Arm Bush	1.4, 1.6, 1.8, 1.9 D, 1.9 SDI, 1.9 TD, 1.9 TDI, 2.0, 2.8 VR6	without guide sleeve	<b>F8-1007</b>	H1=26; H2=41; d=17; D1=60; D2=68
Control Arm-/Trailing Arm Bush	1.4, 1.6, 1.8, 1.9 D, 1.9 SDI, 1.9 TD, 1.9 TDI, 2.0, 2.8 VR6	with guide sleeve	<b>F8-1007S</b>	H1=26; H2=41; d=17; D1=60; D2=68
Repair Kit, link	1.4, 1.6, 1.8, 1.9 D, 1.9 SDI, 1.9 TD, 1.9 TDI, 2.0, 2.8 VR6	with guide sleeve	<b>F8-1008</b>	H1=24; H2=41; d=17; D=60
Top Strut Mounting	1.4, 1.6, 1.8, 1.9 TD, 1.9 TDI	ch.→1H-SB019475, 1H-SW062538	<b>F8-1009B</b>	d=14; D=132
Top Strut Mounting	1.6	ch.→1H-SB019475, 1H-SW062538;  AEK	<b>F8-1009B</b>	d=14; D=132
Top Strut Mounting	1.9 D		<b>F8-1009B</b>	d=14; D=132
Top Strut Mounting	1.4, 1.6, 1.8, 1.9 D, 1.9 TD, 1.9 TDI	ch.1H-N-000001→	<b>F8-1009C</b>	H1=39; H2=55; d=14; D=127
Top Strut Mounting	2.0, 2.0 GL		<b>F8-1009C</b>	H1=39; H2=55; d=14; D=127
Engine Mounting	1.6, 1.9 TD, 2.0		<b>F8-1011</b>	H=133; D1=80; D2=108
Engine Mounting	1.8		<b>F8-1011</b>	H=133; D1=80; D2=108
Engine Mounting	1.4, 1.6, 1.8, 1.9 D, 1.9 SDI, 1.9 TD, 2.0, 2.0 GL		<b>F8-1015</b>	H=82; D1=55; D2=71
Top Strut Mounting	1.4, 1.6, 1.8, 1.9 D, 1.9 TD, 1.9 TDI, 2.0, 2.8 VR6	01/1995 →;	<b>F8-1034</b>	H=50; d=27; D=98
Top Strut Mounting	1.4, 1.9 SDI, 1.9 TDI, 2.0 GL, 2.8 VR6		<b>F8-1034</b>	H=50; d=27; D=98
Top Strut Mounting	1.4, 1.6, 1.8, 1.9 D, 1.9 TD, 1.9 TDI, 2.0, 2.8 VR6	01/1995 →;	<b>F8-1034S</b>	H=51; d=14; D=96
Top Strut Mounting	1.4, 1.9 SDI, 1.9 TDI, 2.0 GL, 2.8 VR6		<b>F8-1034S</b>	H=51; d=14; D=96
Anti-Friction Bearing	1.4, 1.6, 1.8, 1.9 D, 1.9 TD, 1.9 TDI, 2.0		<b>F8-3036</b>	
Anti-Friction Bearing	1.4, 1.6, 1.8, 1.9 D, 1.9 TD, 1.9 TDI, 2.0	08/1994 →	<b>F8-3039</b>	H=14; d1=14; D=45
Anti-Friction Bearing	1.6, 1.9 SDI, 1.9 TDI, 2.0 GL, 2.8 VR6		<b>F8-3039</b>	H=14; d1=14; D=45
Engine Mounting	1.9 TDI, 2.8 VR6		<b>F8-3041</b>	H=85; D1=69; D2=71; $\tau$ [mm]=106
Stabiliser Mounting	1.4, 1.6, 1.8, 1.9 D, 1.9 SDI, 1.9 TD, 1.9 TDI, 2.0, 2.0 GL, 2.8 VR6		<b>F8-3042</b>	H=33; d=17; W=35
Flange, carburettor	1.8		<b>F8-3048</b>	H=27; d=40
Engine Mounting	1.8	01/1996 →;	<b>F8-3053</b>	H=135; D1=79; D2=93
Engine Mounting	1.9 D, 1.9 SDI, 1.9 TD		<b>F8-3053</b>	H=135; D1=79; D2=93
Mounting, axle beam	1.4, 1.6, 1.8, 1.9 D, 1.9 SDI, 1.9 TD, 1.9 TDI, 2.0, 2.8 VR6		<b>F8-4008</b>	H1=54; H2=90; d=12; D=56
Repair Set, axle beam	1.4, 1.6, 1.8, 1.9 D, 1.9 SDI, 1.9 TD, 1.9 TDI, 2.0, 2.8 VR6	with fastening material	<b>F8-4008S</b>	H1=54; H2=90; d=12; D=56
Engine Mounting	1.6, 2.0	01/1996 →;	<b>F8-4016</b>	
Engine Mounting	1.9 TD		<b>F8-4016</b>	
Engine Mounting	1.4, 1.6		<b>F8-4017</b>	
Holder, exhaust system	1.4, 1.6, 1.8, 1.9 D, 1.9 SDI, 1.9 TD, 1.9 TDI, 2.0, 2.8 VR6		<b>F8-4025</b>	H=65; $\tau$ [mm]=86; W=35
Rubber Buffer, suspension	1.4, 1.6, 1.8, 1.9 D, 1.9 TD, 1.9 TDI, 2.0		<b>F8-4063</b>	H=83; d1=18; d2=25; D1=48; D2=60

<b>F8-1007</b>	<b>F8-1007S</b>	<b>F8-1008</b>	<b>F8-1009B</b>	<b>F8-1009C</b>	<b>F8-1011</b>	<b>F8-1015</b>
Ref.Nr.: 191407181A	Ref.Nr.: 191407181A	Ref.Nr.: 191407181E	Ref.Nr.: 176412329	Ref.Nr.: 357412329	Ref.Nr.: 1H0199262F	Ref.Nr.: 357199402
<b>F8-1034</b>	<b>F8-1034S</b>	<b>F8-3036</b>	<b>F8-3039</b>	<b>F8-3041</b>	<b>F8-3042</b>	<b>F8-3048</b>
Ref.Nr.: 357412331A	Ref.Nr.: 7201848S1	Ref.Nr.: 377412335A	Ref.Nr.: 357412249A	Ref.Nr.: 357199402A	Ref.Nr.: 191411314	Ref.Nr.: 050129761B
<b>F8-3053</b>	<b>F8-4008</b>	<b>F8-4008S</b>	<b>F8-4016</b>	<b>F8-4017</b>	<b>F8-4025</b>	<b>F8-4063</b>
Ref.Nr.: 1H0199609B	Ref.Nr.: 1H0501541A	Ref.Nr.: 1H0501541	Ref.Nr.: 1H0199262G	Ref.Nr.: 1H0199262E	Ref.Nr.: 1H0253144	Ref.Nr.: 191412303A

**Article Description****Article Nr.****Fitting Position**

<b>VENTO (1H2)</b>			<b>11/1991 → 09/1998</b>	
Bellow, steering	1.4, 1.6, 1.8, 1.9 D, 1.9 SDI, 1.9 TD, 1.9 TDI, 2.0, 2.8 VR6		<b>F8-4069</b>	
Bellow, steering	1.4, 1.6, 1.8, 1.9 D, 1.9 TD, 1.9 TDI, 2.0, 2.8 VR6	for steering manufacturer: ZF;	<b>F8-4076</b>	H=151; D1=20; D2=55
Bellow, steering	1.9 SDI, 2.0 GL, 2.8 VR6		<b>F8-4076</b>	H=151; D1=20; D2=55
Bellow, driveshaft	1.4, 1.6, 1.9 D, 1.9 SDI, 1.9 TD, 1.9 TDI		<b>F8-4080</b>	H=95; D1=29; D2=96
Mounting, steering gear	1.4, 1.6, 1.8, 1.9 D, 1.9 SDI, 1.9 TD, 1.9 TDI, 2.0, 2.8 VR6		<b>F8-5145</b>	d1=50.7; d2=48.3
Engine Mounting	1.6, 2.0 GL	Brown	<b>F8-5346</b>	
Engine Mounting	2.0	Brown;  2E, ADY, AGG	<b>F8-5346</b>	
Spring Cap	1.4, 1.6, 1.8, 1.9 D, 1.9 SDI, 1.9 TD, 1.9 TDI, 2.0, 2.0 GL, 2.8 VR6		<b>F8-5362</b>	
Spring Mounting	1.4, 1.6, 1.8, 1.9 D, 1.9 SDI, 1.9 TD, 1.9 TDI, 2.0, 2.8 VR6		<b>F8-5393</b>	
Mounting, steering gear	1.4, 1.6, 1.8, 1.9 D, 1.9 SDI, 1.9 TD, 1.9 TDI, 2.0, 2.0 GL, 2.8 VR6		<b>F8-5394</b>	
Stabiliser Mounting	1.4, 1.6, 1.8, 1.9 D, 1.9 SDI, 1.9 TD, 1.9 TDI, 2.0, 2.0 GL, 2.8 VR6	Stabi. Diam. [mm]= 21.5	<b>F8-5395</b>	d=19
Engine Mounting	1.9 TDI		<b>F8-5396</b>	
Engine Mounting	1.9 TDI	1Z, AHU	<b>F8-5396</b>	
Engine Mounting	1.6, 1.8		<b>F8-5397</b>	
Engine Mounting	1.4		<b>F8-5398</b>	
Engine Mounting	1.6	ABU	<b>F8-5398</b>	
Engine Mounting	1.9 SDI, 1.9 TDI		<b>F8-5399</b>	
Engine Mounting	2.8 VR6		<b>F8-5400</b>	
Top Strut Mounting	1.4, 1.6, 1.8, 1.9 D, 1.9 SDI, 1.9 TD, 1.9 TDI, 2.8 VR6		<b>F8-5402</b>	
Top Strut Mounting	2.0		<b>F8-5402</b>	
Top Strut Mounting	1.4, 1.6, 1.8, 1.9 D, 1.9 SDI, 1.9 TD, 1.9 TDI, 2.0, 2.8 VR6		<b>F8-5403</b>	
Engine Mounting	1.4, 1.6, 1.8, 1.9 D, 1.9 SDI, 1.9 TD, 1.9 TDI, 2.0, 2.8 VR6	ch.→1H-PB010000, 1H-PW-080000	<b>F8-5554</b>	H=39.5; d1=16; d2=24; D=50
Spring Cap	1.4, 1.6, 1.8, 1.9 D, 1.9 TD, 2.0, 2.8 VR6	01/1994 →	<b>F8-5580</b>	D=92
Spring Cap	1.6, 1.9 SDI, 1.9 TDI		<b>F8-5580</b>	D=92
Rubber Buffer, suspension	1.4, 1.6, 1.8, 1.9 D, 1.9 SDI, 1.9 TD, 1.9 TDI, 2.0 GL		<b>F8-5594</b>	H=146; d=10.5; D=55.6
Rubber Buffer, suspension	1.9 TDI	1Z	<b>F8-5594</b>	H=146; d=10.5; D=55.6
Rubber Buffer, suspension	2.0	01/1996 →;  ADY;	<b>F8-5594</b>	H=146; d=10.5; D=55.6
Belt Pulley, crankshaft	1.9 D, 1.9 SDI, 1.9 TD, 1.9 TDI	Number of Ribs: 5; Parameter: 6PK	<b>F8-5649</b>	H=31.5; d=30.02; Mounting points diam.[mm]=8.5; D1=161.5; D2=160.5
Holder, engine mounting	1.4, 1.6, 1.8, 1.9 D, 1.9 SDI, 1.9 TD, 1.9 TDI, 2.0, 2.8 VR6		<b>F8-5672</b>	H=39.5; D=24

<b>F8-4069</b>	<b>F8-4076</b>	<b>F8-4080</b>	<b>F8-5145</b>	<b>F8-5346</b>	<b>F8-5362</b>	<b>F8-5393</b>
Ref.Nr.: 171419831B	Ref.Nr.: 357422831B	Ref.Nr.: 113501149	Ref.Nr.: 191419883	Ref.Nr.: 1H0199609G	Ref.Nr.: 191512113	Ref.Nr.: 1H0512149
<b>F8-5394</b>	<b>F8-5395</b>	<b>F8-5396</b>	<b>F8-5397</b>	<b>F8-5398</b>	<b>F8-5399</b>	<b>F8-5400</b>
Ref.Nr.: 1H0422884	Ref.Nr.: 1H0411314	Ref.Nr.: 1H0199609J	Ref.Nr.: 1H0199609F	Ref.Nr.: 1H0199609E	Ref.Nr.: 1H0199262L	Ref.Nr.: 1H0199262D
<b>F8-5402</b>	<b>F8-5403</b>	<b>F8-5554</b>	<b>F8-5580</b>	<b>F8-5594</b>	<b>F8-5649</b>	<b>F8-5672</b>
Ref.Nr.: 191512335	Ref.Nr.: 191512333	Ref.Nr.: 191199233	Ref.Nr.: 1J0412341	Ref.Nr.: 191512131B	Ref.Nr.: 028105243T	Ref.Nr.: 1H0199233A

**Article Description**

**Article Nr.**
**Fitting Position**

<b>VENTO (1H2)</b>			<b>11/1991 → 09/1998</b>		
Holder, engine mounting	1.4, 2.0 GL, 2.8 VR6	ch.1H-PB010001, 1H-PW080001→	<b>F8-5672</b>		H=39.5; D=24
Protective Cap/Bellow, shock absorber	All Models		<b>F8-5683</b>		H=210
Protective Cap/Bellow, shock absorber	1.4, 1.6, 1.8, 1.9 D, 1.9 SDI, 1.9 TD, 1.9 TDI, 2.0, 2.0 GL, 2.8 VR6		<b>F8-5747</b>		H=90
Rubber Buffer, suspension	1.4, 1.6, 1.8, 1.9 D, 1.9 TD, 1.9 TDI, 2.0	09/1994 →	<b>F8-5993</b>		H=83
Rubber Buffer, suspension	1.6, 1.9 TDI, 2.8 VR6		<b>F8-5993</b>		H=83
Repair Kit, suspension strut	1.4, 1.6, 1.8, 1.9 D, 1.9 SDI, 1.9 TD, 1.9 TDI, 2.0, 2.8 VR6		<b>F8-6382</b>		
Sleeve, control arm mounting	All Models		<b>F8-6699</b>		d=16; L=50; D=17
Engine Mounting	2.8 VR6		<b>F8-6717</b>		
Engine Mounting	1.4		<b>F8-6922</b>		H=65
Engine Mounting	1.6		<b>F8-6922</b>		H=65
Bellow, driveshaft	1.4, 1.6, 1.9 D, 1.9 SDI		<b>F8-7722</b>		d1=26; d2=78; L=110
Bellow, driveshaft	1.6		<b>F8-7722</b>		d1=26; d2=78; L=110
Control Arm-/Trailing Arm Bush	All Models		<b>F8-7978</b>		
Control Arm-/Trailing Arm Bush	1.4, 1.6, 1.8, 1.9 D, 1.9 SDI, 1.9 TD, 1.9 TDI, 2.0, 2.8 VR6		<b>G9-648</b>		H=54; d=12; D1=33; D2=36
Bellow, steering	All Models	for steering gear manufacturer: TRW; with clamps;	<b>LM-10003S</b>		d1=9; d2=43; L [mm]=210
Bellow, steering	All Models	with clamps	<b>LM-10006S</b>		d1=10; d2=41; L [mm]=210
Bellow, steering	1.4, 1.6, 1.8, 1.9 D, 1.9 TD, 1.9 TDI, 2.0, 2.0 GL	ch.→1H-TW500000; with clamps;	<b>LM-10024S</b>		d1=25; d2=41; L [mm]=120
Bellow, steering	1.6	ch.→1H-TW500000; with clamps;	<b>LM-10024S</b>		d1=25; d2=41; L [mm]=120
Bellow, steering	All Models	Manufacturer Restriction: ZF; with clamps;	<b>LM-10029S</b>		d1=13; d2=45; L [mm]=138
Bellow, steering	1.4, 1.6, 1.8, 1.9 D, 1.9 TD, 1.9 TDI, 2.0, 2.0 GL	ch.→1H-TW500000; with clamps;	<b>LM-10050S</b>		d1=25; d2=39; L [mm]=126
Bellow, steering	1.6	ch.→1H-TW500000; with clamps;	<b>LM-10050S</b>		d1=25; d2=39; L [mm]=126
Bellow, driveshaft	1.4, 1.6, 1.9 D, 1.9 SDI		<b>M-830220</b>		
Bellow Set, drive shaft	1.4, 1.6, 1.9 D, 1.9 SDI		<b>MK-830220</b>		
Bellow Set, drive shaft	1.6		<b>MK-830220</b>		
Bellow Set, drive shaft	1.9 D, 1.9 SDI		<b>MK-830220S</b>		
<b>DERBY Saloon</b>			<b>01/1995 → 12/2009</b>		
Top Strut Mounting	All Models	for OE: 1J0412319C	<b>F8-7133</b>		
<b>PASSAT [USA] Saloon</b>			<b>01/1990 → 12/1993</b>		
Control Arm-/Trailing Arm Bush	2.0		<b>F8-7908</b>		H=45; d=12; D=38

<b>F8-5672</b>	<b>F8-5683</b>	<b>F8-5747</b>	<b>F8-5993</b>	<b>F8-6382</b>	<b>F8-6699</b>	<b>F8-6717</b>
Ref.Nr.: 1H0199233A	Ref.Nr.: 357413175A	Ref.Nr.: 191513425	Ref.Nr.: 357412303F	Ref.Nr.: 191512333S	Ref.Nr.: 191407190A	Ref.Nr.: 1H0199609D
<b>F8-6922</b>	<b>F8-7133</b>	<b>F8-7722</b>	<b>F8-7908</b>	<b>F8-7909</b>	<b>F8-7978</b>	<b>G9-648</b>
Ref.Nr.: 191199381A	Ref.Nr.: 1J0412319C	Ref.Nr.: 191407285F	Ref.Nr.: 1K0505279A	Ref.Nr.: 1K0505553 A	Ref.Nr.: 357407182F	Ref.Nr.: 357407182
<b>LM-10003S</b>	<b>LM-10006S</b>	<b>LM-10024S</b>	<b>LM-10029S</b>	<b>LM-10050S</b>	<b>M-830220</b>	<b>MK-830220</b>
Ref.Nr.: 357422831A	Ref.Nr.: 1H0422831B	Ref.Nr.: 171419831B	Ref.Nr.: 1H0422831A	Ref.Nr.: 171419831C	Ref.Nr.: 191498203C	Ref.Nr.: 171498203

**Article Description****Article Nr.****Fitting Position**

<b>PASSAT [USA] Saloon</b>			<b>01/1990 → 12/1993</b>	
Control Arm-/Trailing Arm Bush	2.0		<b>F8-7909</b>	
<b>SPORTVAN [USA]</b>			<b>01/2007 → 12/2009</b>	
Anti-Friction Bearing	All Models		<b>F8-6569</b>	
Protective Cap/Bellow, shock absorber	All Models		<b>F8-7132</b>	⊕ ⊕ H=190
<b>TOUAREG [USA]</b>			<b>01/2004 → 12/2004</b>	
Dust Cover Kit, shock absorber	All Models	for OE: 1BK; ;	<b>AK-735190</b>	⊕ ⊕
Dust Cover Kit, shock absorber	All Models	;	<b>AK-735191</b>	⊕ ⊕
Rubber Buffer, suspension	All Models	for OE: 1BK; ;	<b>F8-7805</b>	H=64
Protective Cap/Bellow, shock absorber	4.9 20V D AWD	;	<b>F8-7806</b>	H=180
Protective Cap/Bellow, shock absorber	4.9 20V D AWD	;	<b>F8-7806</b>	H=180
Rubber Buffer, suspension	All Models	for OE: 1BA; <b>ST</b>	<b>F8-7807</b>	H=90
Rubber Buffer, suspension	All Models	;	<b>F8-7808</b>	H=76
<b>TOUAREG [USA] Sport Utility</b>			<b>01/2004 → 12/2007</b>	
Dust Cover Kit, shock absorber	All Models	for OE: 1BK; ;	<b>AK-735190</b>	⊕ ⊕
Dust Cover Kit, shock absorber	All Models	;	<b>AK-735191</b>	⊕ ⊕
Protective Cap/Bellow, shock absorber	3.2 24V AWD, 3.6 24V AWD, 4.2 40V AWD	for OE: 1BA, 1BE; ; <b>SP</b> , <b>ST</b>	<b>F8-7804</b>	H=214
Protective Cap/Bellow, shock absorber	3.2 24V AWD, 3.6 24V AWD, 4.2 40V AWD	for OE: 1BA, 1BE; ; <b>SP</b> , <b>ST</b>	<b>F8-7804</b>	H=214
Rubber Buffer, suspension	All Models	for OE: 1BK; ;	<b>F8-7805</b>	H=64
Protective Cap/Bellow, shock absorber	3.2 24V AWD, 3.6 24V AWD, 4.2 40V AWD	;	<b>F8-7806</b>	H=180
Protective Cap/Bellow, shock absorber	3.2 24V AWD, 3.6 24V AWD, 4.2 40V AWD	;	<b>F8-7806</b>	H=180
Rubber Buffer, suspension	All Models	for OE: 1BA; <b>ST</b>	<b>F8-7807</b>	H=90
Rubber Buffer, suspension	All Models	;	<b>F8-7808</b>	H=76

<b>AK-735190</b>	<b>AK-735191</b>	<b>F8-6569</b>	<b>F8-7132</b>	<b>F8-7804</b>	<b>F8-7805</b>	<b>F8-7806</b>
Ref.Nr.: 7L0412303A	Ref.Nr.: 7L0498137	Ref.Nr.: 6N0412249C	Ref.Nr.: 6N0413175A	Ref.Nr.: 7L0412137	Ref.Nr.: 7L0412303A	Ref.Nr.: 7L0498137
<b>F8-7807</b>	<b>F8-7808</b>	<b>F8-7909</b>				
Ref.Nr.: 7L0512131B	Ref.Nr.: 7L0512131C	Ref.Nr.: 1K0505553 A				





ALFA ROMEO		ALFA ROMEO		AUDI		AUDI	
07601502	F8-3015	7588037	AK-735088	045105243	F8-8038	191498203D	M-830220
077 824 35	F8-6631	7601064	G9-530	045105243C	F8-8038	1H0412303A	F8-4063
40504729	F8-5604	7601065	G9-532	045903119A	F5-1085	1H0412303B	AK-735039
46413115	F8-7863	7601068	G9-531	050129761A	F8-3048	1H0412303B	F8-5996
46791956	F8-7418	7601502	F8-3015	050129761B	F8-3048	1H0422831	LM-10003S
50510134	F8-7421	7644686	F8-6914	050129761C	F8-3047	1H0422831	LM-10006S
50521707	F8-7421	77362721	F5-1045	050129761D	F8-4012	1H0422831A	LM-10029S
50703431	F8-7419	77364148	F5-1067	050129761E	F8-3045	1H0422831B	LM-10003S
50704983	F8-7420	77364723	F5-1041	050129761F	F8-3048	1H0422831B	LM-10006S
50705805	F8-7419	77364725	F5-1098	050129761H	F8-3048	1J0 411 336 B	F8-6579
50706954	F8-6438	77365271	F5-1147	051129761	F8-3047	1J0 411 336 C	F8-6579
50706955	F8-6437	7782435	F8-6631	052129765A	F8-4013	1J0 411 336 D	F8-6579
50707075	F8-7420	7792020	F8-6632	058903119C	F5-1012	1J0 498 201G	MK-810160
50707110	F8-7419	82388242	F8-5640	059903119G	F5-1140	1J0199262BE	F8-5390
50707987	AK-735314	82423607	AK-735152	059903119H	F5-1140	1J0199262BF	F8-5404
51780702	F8-7422	82430666	F8-5603	059903119L	F5-1140	1J0199262P	F8-6960
51831016	F8-7421	9613305380	F8-6236	068121275	F8-4011	1J0199429	F8-5907
55184474	F8-7087	9947921	LM-10038S	06A105243E	F8-5650	1J0199555AH	F8-5387
55187707	F8-7087	9948513	F5-1123	06B105243F	F8-5650	1J0199555AJ	F8-5386
55196301	F8-6393	9949129	F5-1123	06B903119B	F5-1044	1J0199555AK	F8-5385
55215574	F8-7087	9951162	F5-1005	06B903119D	F5-1044	1J0199851AA	F8-5383
55700751	F8-7995	9951269	F5-1123	06E903119Q	F5-1146	1J0199851M	F8-5383
55700767	F8-7663	9951287	LM-10038S	06E903119R	F5-1149	1J0199851N	F8-5383
55701796	F8-7422	<b>AUDI</b>		074105251AC	F8-5202	1J0407181	G9-649
55701901	F8-7424	021156017A	F8-3036	074105251AC	F8-5202K1	1J0411314AC	F8-7927
55701902	F8-7423	026129761A	F8-3044	074105251N	F8-5202	1J0411314B	F8-5215
60501446	F8-3062	026129761E	F8-3044	074105251N	F8-5202K1	1J0411314C	F8-5221
60501466	F8-3062	027129761	F8-3045	074105251R	F8-5202K1	1J0411314M	F8-5221
60504729	F8-5604	027129761A	F8-3045	074105251T	F8-5202	1J0411314N	F8-5221
60507890	F8-5607	027129761F	F8-3045	074105251T	F8-5202K1	1J0411314P	F8-7901
60507954	F8-5603	028105243Q	F8-5654	078903119G	F5-1043	1J0411314R	F8-5221
60521240	F8-6456	028105243T	F8-5649	113501149	F8-4080	1J0411314S	F8-5215
60544490	F8-5593	028903119AN	F5-1008	171253147	F8-4027	1J0411314T	F8-5220
60544493	AK-735152	028903119AP	F5-1010	171253147A	F8-4027	1J0411327	F8-5382
60566146	F8-5593	028903119S	F5-1010	171419832A	F8-4074	1J0412131	F8-6012
60570447	F8-5593	028903119T	F5-1008	171419832C	F8-4074	1J0412131B	F8-6013
60570731	F8-5605	038 105 243	F8-7864	175422831	LM-10003S	1J0412131C	F8-6007
60570732	F8-5606	038105243	F8-6392	175422831	LM-10006S	1J0412249	F8-3039
60585431	AK-735088	038105243F	F8-6391	176412303A	F8-4063	1J0412249	F8-6280
6060787	LM-10062S	038105243K	F8-6392	176412329A	F8-1009B	1J0412303	AK-735410
60613572	F8-6353	038105243M	F8-6572	191253147C	F8-4027	1J0412303	F8-6041
60625002	F8-6289	038903119	F5-1009	191407182	G9-648	1J0412319C	F8-7133
60650551	AK-735066	038903119L	F5-1013	191412135	F8-4064	1J0412331	F8-4067
60663773	F8-6353	038903119L	F5-1016	191412249	F8-3036	1J0412331	F8-6280
60683272	AK-735066	038903119M	F5-1006	191412303	AK-733023	1J0412331B	F8-4067
60724111	LM-10037S	038903119P	F5-1002	191412303	F8-4063	1J0412331B	F8-6280
60724154	LM-10037S	038903119T	F5-1004	191412303A	AK-733023	1J0412331C	F8-4067
60805971	F8-6914	03C903119C	F5-1064	191412303A	F8-4063	1J0412331C	F8-6280
60806398	F8-3015	03C903119F	F5-1064	191412303C	F8-4063	1J0412341	F8-5580
60813084	F8-6632	03G105243	F8-6396	191412329	F8-1009B	1J0422831	LM-10020S
60813790	F8-7863	03G105243C	F8-6396	191422831	LM-10003S	1J0422831B	LM-10020S
71747796	F8-7087	03G903119B	F5-1085	191422831	LM-10006S	1J0501541B	F8-5340



AUDI		AUDI		AUDI		AUDI	
1J0501541C	F8-5340	1K0407183G	F8-7991	357513425	AK-735040	4A0399151C	F8-5544
1J0501541D	F8-6076	1K0407183L	F8-6736	377412335A	F8-3036	4A0399151D	F8-4029
1J0501541DS	F8-6077	1K0412303B	F8-7131	3B0512131H	F8-6001	4A0399151K	F8-4029
1J0501541DS1	F8-6077	1K0412303F	F8-7697	3C0199231E	F8-6701	4A0399415	F8-5543
1J0505145B	F8-7046	1K0412303P	AK-735180	3C0199855A	F8-7851	4A0399415B	F8-5543
1J0512131	F8-6012	1K0412303P	F8-7832	3C0199855J	F8-7851	4A0399419C	F8-3003
1J0512131B	AK-735095	1K0412303S	F8-7831	3C0511359	F8-7140	4A0399419D	F8-3003
1J0512131B	F8-6013	1K0412303T	F8-7833	3C0513353	F8-7603	4A0399419E	F8-3003
1J0512131C	AK-735411	1K0412331B	F8-6284	3C0513353C	F8-7603	4A0399420	F8-3056
1J0512131C	F8-6007	1K0412331B	F8-6570	3C0513353D	F8-7603	4A0399420C	F8-3004
1J0512149B	F8-5381	1K0412331C	F8-6284	3C0513425	F8-6044	4A0399420D	F8-3004
1J0513353A	F8-5380	1K0412331C	F8-6570	431121273	F8-4009	4A0399420E	F8-3004
1J0513353B	F8-5380	1K0505171C	F8-7902	431399151D	F8-4028	4A0407181A	F8-1024
1J0513353C	F8-5380	1K0505203A	F8-7907	431399415B	F8-1022	4A0407183D	G9-617
1J0513353D	F8-6040	1K0505279A	F8-7908	431399419A	F8-3002	4A0411327A	F8-3006
1J0513353G	F8-5380	1K0505541C	F8-6463	431407181F	F8-1017	4A0412131	F8-5763
1J0513425	F8-6044	1K0505541D	F8-6463	431407182	F8-1017	4A0412249	F8-3008
1J0513425A	AK-735095	1K0505553A	F8-7909	431407183A	F8-1018	4A0412377A	F8-3009
1J0513425A	AK-735411	1K0511327AP	F8-7930	431412175D	F8-4066	4A0412377A	F8-7453
1J0513425A	F8-6045	1K0511327AR	F8-7923	431412249D	F8-3007	4A0412377B	F8-3009
1K0 199 262 AT	F8-6528	1K0511353J	AK-735181	431412377C	F8-1023	4A0412377B	F8-7453
1K0 511 353 J	F8-7579	1K0511353N	F8-7601	431412377D	F8-1023	4A0412377C	F8-3009
1K0 511 353 M	F8-7576	1K0511353S	F8-7835	431419831	F8-4070	4A0412377C	F8-7453
1K0199231G	F8-6425	1K0513353G	F8-6348	431505172	F8-5344	4A0412377CS	F8-7453
1K0199231J	F8-6425	1K0513353H	F8-6349	431511247C	F8-1019	4A0511247	F8-5342
1K0199232G	F8-6424	1K0513353R	F8-7603	441412249A	F8-3007	4A0511247B	F8-5306
1K0199232J	F8-6424	1K0513425	AK-735181	443199379	F8-1020	4A0511249	F8-5778
1K0199262AB	F8-6989	1K0513425A	F8-7640	443199379E	F8-4021	4A0512129	AK-735125
1K0199262AC	F8-6988	1K0513425D	F8-7627	443199381	F8-4022	4B0 199 379 E	F8-6530
1K0199262AJ	F8-6531	1T0511359	F8-7836	443199381C	F8-1020	4B0 399 151 AA	F8-6470
1K0199262AL	F8-6988	27129761	F8-3045	443199381J	F8-6925	4B0 399 151 P	F8-6471
1K0199262AM	F8-6989	2D0 598 351	F8-6240	443199382	F8-1021	4B0399151M	F8-7971
1K0199262AR	F8-7008	3266405	F8-3036	443399415A	F8-1022	4B0407515	F8-5542
1K0199262AS	F8-7958	357407182	G9-648	443399419	F8-3001	4B0501521E	F8-6431
1K0199262CG	F8-7959	357407182F	F8-7978	443399419A	F8-3002	4B0501522E	F8-6430
1K0199262J	F8-6531	357412135	AK-733023	443411327	F8-3005	4B0511327	F8-7979
1K0199262L	F8-6988	357412135	F8-4064	443412121A	F8-4061	4B0512131B	F8-6003
1K0199262M	F8-6989	357412249	F8-3039	443412131A	F8-4061	4B0512131N	F8-6005
1K0199262Q	F8-7008	357412249A	F8-3039	443412377	F8-1023	4B0512137B	AK-735450
1K0199262T	F8-6531	357412249A	F8-5523	443511247D	F8-5777	4B0512137B	F8-7802
1K0199555L	F8-7960	357412303E	AK-733023	443511523B	F8-5541	4D0407181F	F8-4044
1K0199555N	F8-7961	357412303E	F8-4063	443512331	F8-3010	4D0407181H	F8-4044
1K0199555Q	F8-7962	357412303F	F8-5993	49129761	F8-3046	4D0407182E	F8-4045
1K0199555T	F8-8152	357412341A	F8-5580	4A0018977	F8-5548	4D0407182G	F8-4045
1K0199855BA	F8-7965	357413175A	AK-735039	4A0199351B	F8-5547	4D0407183D	G9-615
1K0199855BB	F8-7966	357413175A	AK-735410	4A0199352A	F8-5546	4D0407183M	G9-615
1K0199867Q	F8-7981	357413175A	F8-5683	4A0199379A	F8-5545	4D0407183N	G9-615
1K0199868Q	F8-7982	357422831	LM-10003S	4A0199379B	F8-5545	4D0407183P	G9-615
1K0407182	F8-5633	357422831	LM-10006S	4A0199379C	F8-5545	4D0407183Q	G9-615
1K0407182A	F8-5633	357422831A	LM-10003S	4A0199379G	F8-6747	4D0407515	G9-616
1K0407183A	F8-6736	357422831A	LM-10006S	4A0253147	F8-4026	4D0407515C	G9-616
1K0407183E	F8-6736	357422831B	LM-10029S	4A0253147A	F8-4026	4D0407516C	F8-5471





AUDI		AUDI		AUDI		AUDI	
4D0411327E	F8-5063	4F0407183C	F8-6580	6R0513353	F8-5380	823199419	F8-5685
4D0411327F	F8-5064	4F0407183E	F8-6580	6R0513353B	F8-5380	823253147A	F8-4026
4D0411327G	F8-5063	4F0412377B	F8-7454	74105193	F8-5202K1	823253147D	F8-4026
4D0411327H	F8-5064	4F0412377D	F8-7454	74105251N	F8-5202	823407181	F8-4042
4D0411327J	F8-7922	4F0498998	G8-562	74105251N	F8-5202K1	823411313A	F8-1029
4D0412131C	F8-6042	4F0512131A	F8-7707	7L0407077	F8-6705	823411327B	F8-5225
4D0412137B	F8-7687	4F0512131D	F8-7844	7L0407182C	F8-6706	823412249	F8-3036
4D0412137C	AK-735101	4F0512131G	F8-7844	7L0407182D	F8-7875	823419831	F8-4070
4D0412137C	F8-7687	4F0513353B	F8-6352	7L0407182E	F8-6706	823511247A	F8-5686
4D0412377D	F8-3050	4F0513353C	F8-6352	7L0407182F	F8-7875	857407181	F8-4043
4D0412377D	F8-7096	4F0513353D	F8-6352	7L0407182G	F8-7875	861407183	F8-5132
4D0412377D	F8-7097	4G0412131	F8-7842	7L0407183A	F8-6707	861411313E	F8-5148
4D0412377DS	F8-7096	4G0512131D	F8-7843	7L0412137	AK-735182	867199383A	F8-6832
4D0412377DS	F8-7097	4G0512131F	F8-7704	7L0412137	F8-7804	867411313	F8-5148
4D0412377F	F8-3050	4G0512137A	F8-7813	7L0412303A	F8-7805	871412323A	F8-5738
4D0412377F	F8-7096	4H0407183B	F8-8090	7L0412333A	F8-5301	883412249	F8-3036
4D0412377F	F8-7097	4H6411317A	F8-8089	7L0422831A	LM-10100S	893199339	F8-4019
4D0419831A	F8-7148	51129761	F8-3047	7L0498137	AK-735183	893199339A	F8-5524
4D0419831A	LM-10093S	68121275	F8-4011	7L0498137	F8-7806	893199339D	F8-4020
4D0419831B	LM-10005S	6N0 199 851 AG	F8-6501	7L0499035A	F8-8131	893199381B	F8-3000
4D0419831D	LM-10005S	6N0412249B	F8-6281	7L0512131B	AK-735183	893199381C	F8-6834
4D0511523A	F8-5541	6N0412249B	F8-6569	7L0512131B	F8-7807	893199415	F8-1031
4D0511523B	F8-5541	6N0412249C	F8-6281	7L0512131C	F8-7808	893199419	F8-1032
4D0511523C	F8-5541	6N0412249C	F8-6284	7L8412303	AK-735182	893399151	F8-6212
4E0407181B	F8-6784	6N0412249C	F8-6569	7L8412303	F8-7803	893399151A	F8-4031
4E0407182B	F8-7795	6N0412249D	F8-6281	7M0422831B	F8-5051	893407181	F8-3057
4E0407182C	F8-7795	6N0412249D	F8-6284	803121273	F8-4011	893411327C	F8-4059
4E0407183	F8-8117	6N0412249D	F8-6569	811199415A	F8-1031	893411327E	F8-4059
4E0407183A	F8-8117	6N0412331D	F8-5537	811199419A	F8-5685	893412131B	F8-4062
4E0407183B	F8-8117	6N0412331D	F8-6281	811199419B	F8-1032	893512131	F8-4086
4E0407183H	F8-8117	6N0412331E	F8-5537	811199419C	F8-1032	8A0121273	F8-4010
4E0407515D	F8-7796	6N0412331E	F8-6281	811399151A	F8-4030	8A0199379B	F8-5529
4F0 512 131	F8-7578	6N0413175A	AK-735180	811399151B	F8-4030	8A0199379C	F8-6748
4F0199379AP	F8-6743	6N0413175A	F8-7132	811407181	F8-1026	8A0199379E	F8-5529
4F0199379AQ	F8-6744	6N0422831	LM-10063S	811407181A	F8-1026	8A0199381	F8-6749
4F0199379AS	F8-6534	6Q0 411 314 M	F8-6461	811407181F	F8-1026	8A0199382A	F8-6241
4F0199379BF	F8-6743	6Q0199555AB	F8-8173	811411327A	F8-5081	8A0199382B	F8-8180
4F0199379BG	F8-6744	6Q0199555AD	F8-8164	811412131B	F8-4062	8A0199382C	F8-6750
4F0199379BK	F8-6534	6Q0199555AE	F8-8173	811412135A	F8-4065	8A0199382D	F8-6751
4F0199379BL	F8-7970	6Q0199555AR	F8-7951	811412135B	F8-4065	8A0199415B	F8-5528
4F0199382AQ	F8-6745	6Q0199555AS	F8-8164	811412323	F8-1027	8A0199415C	F8-5528
4F0199382AR	F8-6746	6Q0199555AT	F8-8173	811412323C	F8-1027	8A0199419	F8-5527
4F0199382AS	F8-6742	6Q0411314J	F8-6462	811412323D	F8-1027	8A0199419A	F8-5934
4F0199382BH	F8-6745	6Q0411314L	F8-6462	811419831B	F8-4073	8A0253147A	F8-4027
4F0199382BJ	F8-6746	6Q0411314P	F8-6462	811419831B	LM-10026S	8A0407181	F8-4043
4F0199382BK	F8-6742	6Q0412301A	F8-7676	811511247	F8-1028	8A0412323	F8-1027
4F0399151AM	F8-7972	6Q0512131B	F8-6723	811512131	F8-4085	8A0412323B	F8-1027
4F0399151AP	F8-8191	6R0199555	F8-7957	817253147	F8-4026	8A0412323D	F8-1027
4F0399415A	F8-8132	6R0412249	F8-3039	823199381B	F8-3000	8A0501541	F8-3052
4F0399415B	F8-8132	6R0412249	F8-6280	823199381C	F8-6834	8A0505185	F8-7149
4F0399415C	F8-8132	6R0501541A	F8-5340	823199415B	F8-1031	8A0505185A	F8-7149
4F0399419E	F8-7997	6R0501541B	F8-5340	823199415C	F8-1031	8A0511247B	F8-7921



AUDI		AUDI		AUDI		BMW			
8A0512333	F8-5905	8D0501541A	F8-5573	8K0407182B	F8-6582	1094751	AK-735415		
8A0512333	F8-5906	8D0501541D	F8-5343	8K0407183A	F8-7941	1096298	F8-7331		
8A0512335	F8-5904	8D0505171	F8-7924	8K0407183D	F8-7999	1096299	F8-7365		
8A0512335	F8-5906	8D0505185A	F8-7149	8K0412131E	F8-7715	1096309	AK-735413		
8AO412323B	F8-1027	8D0512099A	F8-6347	8K0412131F	F8-7716	1096309	AK-735414		
8D0 412 131 H	F8-7577	8D0512131	F8-5992	8K0412131G	F8-7717	11231438995	F8-5662		
8D0 512 131 J	F8-7598	8D0512149A	F8-6347	8K0412137A	AK-735449	11237513862	F8-5661		
8D0121275	F8-5526	8D0512333	F8-6346	8K0412137A	F8-7681	11237788611	F8-7641		
8D0151541D	F8-5343	8D0512333	F8-7100	8K0412377A	F8-7742	11237793593	F8-7641		
8D0199339A	F8-5524	8D0512333S	F8-6346	8K0412377C	F8-7742	11238511371	F8-7641		
8D0199339E	F8-6758	8D0512335	F8-6346	8K0501529N	F8-8073	1124519	F8-7685		
8D0199339F	F8-4019	8D0512335	F8-7101	8K0501530N	F8-8073	1132088	F8-5932		
8D0199339P	F8-4019	8D0512335S	F8-6346	8K0512131	AK-735450	1134314	F8-7685		
8D0199379A	F8-5565	8D0513353	F8-6347	8K0512131	F8-7704	1135577	F8-7425		
8D0199379G	F8-5565	8D5512131F	F8-7693	8K0512131A	F8-7839	1136283	F8-7684		
8D0199379J	F8-5565	8E0 199 339	F8-7599	8K0512131B	F8-7718	1139436	F8-7425		
8D0199379K	F8-5567	8E0 498 201B	MK-810160	8K0512131D	F8-7719	11811082583	F8-5348		
8D0199379S	F8-5565	8E0199379AF	F8-6961	8K0512131H	F8-7704	11811092583	F8-5348		
8D0199382AP	F8-5579	8E0199379D	F8-6961	8K0512131J	F8-7839	11811132321	F8-5432		
8D0199382G	F8-5579	8E0199379F	F8-6892	8K0512137A	F8-7814	11811132323	F8-6757		
8D0199382K	F8-5579	8E0199382A	F8-8171	8K0513353D	F8-7452	11811137238	F8-5428		
8D0199382L	F8-5538	8E0199382AA	F8-8171	8K0513353E	F8-7452	11811139606	F8-5431		
8D0199382M	F8-5579	8E0199382AH	F8-8171	8N0199555C	F8-7033	11811139883	F8-5430		
8D0399151H	F8-5578	8E0199382J	F8-8171	8N0407181B	F8-6464	11811140985	F8-5348		
8D0399151J	F8-5577	8E0199382K	F8-7969	8N0407182A	F8-6775	11811141377	F8-5428		
8D0399151M	F8-5576	8E0199382Q	F8-8171	8N0411314B	F8-5221	11811141526	F8-6741		
8D0399151P	F8-5577	8E0399105BG	F8-8143	8N0422831	LM-10020S	11811141889	F8-5427		
8D0399151R	F8-8179	8E0399105HB	F8-8143	8R0412131D	AK-735449	11811142032	F8-6741		
8D0399415D	F8-5575	8E0407181B	F8-6151	8R0412131D	F8-7801	11811246437	F8-6757		
8D0399415E	F8-8012	8E0407181C	F8-6151	8Z0199167AQ	F8-6947	11817837985	F8-6215		
8D0399419G	F8-5574	8E0407182E	F8-4045	8Z0199167AR	F8-6948	12314466273	F5-1053		
8D0407515A	F8-7796	8E0412377	F8-7451	8Z0199167AS	F8-6946	12317516099	F5-1051		
8D0407515B	F8-7796	8E0412377C	F8-7451	8Z0199212J	F8-6947	12317516103	F5-1053		
8D0407515C	F8-7796	8E0501521N	F8-6431	8Z0199212K	F8-6948	12317552352	F5-1051		
8D0412065	F8-6282	8E0501522N	F8-6430	8Z0407183	F8-7447	12317552353	F5-1053		
8D0412065	F8-7096	8E0505203D	F8-8133	8Z0407183A	F8-7448	12317560483	F5-1053		
8D0412065D	F8-6283	8E0512099A	F8-6347	8Z0411314B	F8-7914	12317576515	F5-1113		
8D0412065D	F8-7097	8E0512131P	F8-7707	8Z0412331	F8-5537	12317790877	F5-1137		
8D0412065DS	F8-7097	8E0512137E	F8-7682	8Z0412331	F8-6281	22 11 6 779 971	F8-5423		
8D0412065E	F8-6283	8E0513353B	F8-5572	WHT004573	F8-5202K1	22 11 6 779 972	F8-5422		
8D0412065E	F8-7097	8E0513353B	F8-6344	ZBA121273	F8-4011	22111092599	F8-6828		
8D0412065ES	F8-7097	8E0513353C	F8-5572	ZBA121275	F8-4011	22111092600	F8-6829		
8D0412065F	F8-6283	8E0513353C	F8-6344	<b>AUTOBIANCHI</b>				22111092823	F8-5426
8D0412065F	F8-7097	8E0513353D	F8-6352	4288726	G9-506	22111092824	F8-5425		
8D0412065FS	F8-7097	8E0599125J	F8-6737	<b>BMW</b>				22111094248	F8-5424
8D0412065S	F8-7096	8E0599125K	F8-6738	0146239	F8-6545	22111094813	F8-5423		
8D0412131E	F8-6039	8F0412131	F8-7841	1 438 995	F8-5662	22111094814	F8-5422		
8D0412131F	AK-735101	8F0512131E	F8-7840	1090612	F8-3063	22111095444	F8-5348		
8D0412131F	F8-5994	8F0512131G	F8-7840	1090613	F8-3063	22111096514	F8-7879		
8D0412131H	AK-735101	8J0511353F	F8-7894	1094749	AK-735415	22111096997	F8-6714		
8D0419831K	LM-10021S	8J0511353G	F8-7895	1094749	F8-6545	22111097153	F8-6499		
8D0498998PART	G8-529	8K0407182A	F8-6582	1094750	F8-6542	22111097251	F8-6828		



BMW		BMW		BMW		BMW	
22111097267	F8-5405	23711133487	F8-6242	31121128774-PAR	F8-6106	31126855743	F8-8092
22113400335	F8-6995	23711137817	F8-8174	31121130123	G9-624	31129058814	F8-5069
22113400336	F8-6996	24711128372	F8-7022	31121130140	G9-624	31129058814	F8-6105
22113400341	F8-7006	26111227717	F8-6763	31121130587	G9-689	31129058814	F8-6106
22113421295	F8-6995	26111227869	F8-6762	31121133488	G9-689	31129058814-L	F8-6105
22113421296	F8-6996	26111229080	F8-6763	31121133710	G9-687	31129058814-R	F8-6106
22113421299	F8-7006	26111229360	F8-6763	31121136111-PAR	F8-6105	31129058815	G9-623
22114038371	F8-7004	26112226527	F8-6783	31121136112-PAR	F8-6106	31129058815S1	F8-6107
22114038372	F8-7005	26117522027	F8-6767	31121136531	F8-6102	31129058815S2	F8-6108
22114049050	F8-7003	26117527392	F8-6768	31121136532	F8-6103	31129058816	G9-638
22114516677	F8-5405	26117542238	F8-6764	31121136605	G9-688	31129058818	G9-639
22116750039	F8-6499	26121229089	F8-6777	31121136606	G9-689	31129058819	G9-637
22116750109	F8-6216	26121229089	F8-6778	31121136607	F8-5021	31129058820	G9-559
22116750862	F8-6942	26121229089-PAR	F8-6778	31121139456	G9-689	31129058931	F8-6105
22116751281	F8-6499	26121229242	F8-6779	31121139789	F8-6105	31129058931	F8-6106
22116752741	F8-8181	26121229242	F8-6780	31121139789-PAR	F8-6105	31129058931	G9-624
22116752742	F8-8182	26121229242-PAR	F8-6780	31121139790	F8-6106	31129058931S1	F8-6109
22116754608	F8-5405	26121229317	F8-8226	31121139790-PAR	F8-6106	31129058931S2	F8-6110
22116756018	F8-6943	26121229682	F8-8226	31124000612	F8-5281	31129059288	G9-625
22116758444	F8-6714	26121229726	F8-7056	31124004359	F8-5280	31129059288	G9-625S
22116760330	F8-6998	26127507740	F8-7056	31124004359	F8-5281	31129068753	G9-658
22116760332	F8-7003	31 10 6 771 194	F8-6720	31124004360	F8-5281	31129068753	G9-658S
22116761090	F8-8201	31 10 6 771 897	F8-6721	31126750057S1	F8-5281	31129071663	F8-5281
22116765186	F8-6216	31106778015	F8-6719	31126750221	F8-5281	31129071663	F8-6243
22116768799	F8-6999	31111096982	F8-5281	31126750222	F8-5281	31129071952	F8-5281
22116768800	F8-7000	31111137070	LM-10011S	31126751372	F8-5281	31129071952	F8-6243
22116768852	F8-7001	31120305612	F8-6774	31126751435	F8-5281	31129071963	F8-5281
22116768853	F8-7002	31120393540	F8-6724	31126751436	F8-5281	31303411973	AK-735179
22116770638	F8-6714	31121095277	F8-5281	31126753058	F8-5281	31303411973	AK-735414
22116771362	F8-6943	31121095278	F8-5281	31126753059	F8-5281	31303411973	F8-7332
22116773247	F8-7004	31121096372	F8-7797	31126753060	F8-5281	31304038214	AK-735429
22116773248	F8-7005	31121096982	F8-6243	31126754547	F8-5281	3130-6757046	AK-735408
22116773903	F8-6216	31121096983	F8-5281	31126754899	F8-5281	3130-6757046	F8-6544
22312283285	F8-7050	31121096984	F8-5281	31126754900	F8-5281	31306759454	AK-735230
22313400320	F8-7037	31121118682	G9-559	31126757551	F8-5298	31306759455	AK-735228
22313400343	F8-6584	31121124622	G9-527	31126757561	F8-6574	31306767451	F8-5433
22313421301	F8-6584	31121125428	G9-639	31126757562	F8-6575	31306774232	AK-735422
22313422956	F8-7037	31121125429	G9-638	31126757622	G8-544	31306774699	AK-735430
22316750858	F8-8163	31121126302	G9-639	31126757623	F8-5281	31306775098	F8-5433
22316761093	F8-7040	31121126394	G9-637	31126757623	G8-544	3130-6779604	F8-7359
22316761094	F8-7038	31121126426	G9-638	31126763719	F8-6724	31306785962	F8-5433
22316762609	F8-7036	31121127377	F8-5069	31126765991	F8-6133	31306791712	AK-735452
22316769848	F8-7034	31121127377	F8-6105	31126765992	F8-6774	31306791712	F8-7485
22316770289	F8-7038	31121127377	F8-6106	31126767651	G9-527	31321125878	AK-735171
22316771219	F8-8174	31121127377-L	F8-6105	31126769715	F8-7797	31321125878	AK-735179
22316771740	F8-7036	31121127377-R	F8-6106	31126775145	F8-8002	31321125878	F8-7738
22316771741	F8-7040	31121127378	G9-623	31126777849	G8-544	31326769667	F8-6566
22316773125	F8-8163	31121127727-PAR	F8-6105	31126777850	G8-544	3132-6769667	F8-6566
22316773693	F8-8163	31121127728-PAR	F8-6106	31126783375	G8-544	31330146239	AK-735228
22316773825	F8-7036	31121128470-PAR	F8-6105	31126783376	G8-544	31330146239	AK-735230
22316799331	F8-8174	31121128471-PAR	F8-6106	31126851255	F8-8092	31330146239	F8-7336
23 71 1 131 664	F8-6491	31121128773-PAR	F8-6105	31126851261	F8-8092	3133-0146239	F8-6545



BMW		BMW		BMW		BMW	
31331090467	F8-5506	31331139452	F8-5419	32111127104	LM-10052S	33321092247	F8-5746
31331090611	F8-5766	31331140140	AK-735136	32111137070	F8-5171	33321092248	F8-5322
31331090612	F8-3063	31331140140	F8-5869	32131092876	LM-10012S	33321095631	F8-5299
31331090613	F8-3063	3133-1140140	AK-735136	32131094933	F8-5171	33321095631	F8-7353
31331091708	F8-5923	3133-6750892	AK-735407	32131096465	F8-5171	33321097009	F8-5311
31331091709	F8-6413	3133-6750892	F8-6543	32131096910	F8-5171	33321097264	F8-7602
31331091868	AK-735136	31336751594	AK-735413	32131096910	LM-10011S	33321123462	F8-7352
3133-1091868	AK-735136	3133-6751594	F8-7333	32131096910	LM-10078S	33321123462	F8-7352S
31331092885	F8-5506	31336752735	F8-5433	32211136452	F7-2039	33321123463	G7-767
31331094616	F8-5433	31336753966	F8-6084	32211137070	F8-5171	33321125563	F8-7352
31331094749	AK-735415	31336759871	F8-5506	32211139786	F8-5171	33321125563	F8-7352S
31331094749	AK-735420	31336760943	F8-5433	32211139786	LM-10011S	33321125665	G7-767
31331094749	AK-735422	31336764085	AK-735428	33171093008	F8-5887	33321126476	G7-767
31331094749	AK-735424	31336764085	F8-7334	33171093175	F8-5886	33321136311	F8-5321
31331094749	AK-735425	31336764947	F8-5506	33171093565	F8-8230	33321137459	F8-7352
31331094749	AK-735428	31336767320	F8-7812	33171124373	F7-2041	33321137459	F8-7352S
31331094749	AK-735429	31336769582	F8-5433	33171128586	F7-2041	33321137571	F8-5746
31331094749	AK-735430	3133-6769584	F8-7359	33171130874	F8-5772	33321137806	F8-5311
31331094749	F8-7336	31336769585	F8-5506	33171131903	F8-5772	33321138383	F8-5322
3133-1094749	AK-735406	31336769588	F8-6084	33171134872	F8-5839	33321138722	F8-5632
3133-1094749	AK-735407	31336770568	F8-5433	33171134911	F8-5839	33321140345	F8-5632
3133-1094749	AK-735408	31336771352	AK-735420	33171135242	F7-2041	33326750371	F8-5299
3133-1094749	F8-6545	31336771352	F8-7812	33176751808	F8-8230	33326750371	F8-7353
3133-1094750	AK-735406	31336771380	AK-735424	33311090945	F8-6080	33326756249	F8-6250
3133-1094750	F8-6542	31336771380	F8-7846	33311090946	F8-6080	33326763092	F8-6476
31331094751	AK-735415	31336771515	F8-7476	33311090956	F8-5879	33326763473-PAR	F8-6252
31331094751	F8-6088	31336773619	AK-735425	33311092515	F8-5318	33326765425-PAR	F8-6252
31331096298	AK-735412	31336774738	F8-7476	33311092516	F8-5319	33326765535	F8-6252
3133-1096298	F8-7331	31336775097	F8-5433	33311092517	F8-5320	33326767748	F8-5299
3133-1096299	F8-7365	31336776391	F8-7476	33311093662	F8-5300	33326767748	F8-7353
31331096309	AK-735177	31336776554	F8-7487	33311094036	F8-6583	33326768791	F8-7602
31331096309	AK-735412	31336778544	AK-735415	33311127533	F8-5741	33326770786	F8-5311
31331096309	AK-735413	31336778544	F8-6088	33311128670	F8-5317	33326770824	F8-5322
31331096309	AK-735414	31336779612	F8-6084	33311128760	F8-5317	33326771828	F8-5321
3133-1096309	AK-735177	31336779613	F8-5506	33311129144	F8-5003	33326775551	F8-5632
3133-1096309	F8-7337	31336788776	F8-7476	33311129760	F8-5317	33326775552	F8-6250
31331124449	AK-735177	31336791507	AK-735452	33311130488	F8-5741	33326777980-PAR	F8-6252
31331124449	F8-5690	31351093108	F8-7144	33311132257	F8-5771	33326782237-PAR	F8-6252
3133-1124449	AK-735177	31351095271	F8-7933	33313400023	F8-6251	33326782238-PAR	F8-6252
31331124508	F8-5419	31351097021	F8-7996	33313418342	F8-6251	33326786981	F8-6250
31331124519	F8-7685	31351097179	F8-7918	33316757393	F8-5318	33326790493	F8-8093
31331125215	F8-5690	31351126774	F8-5118	33316757394	F8-5319	33326792553	F8-6250
31331133292	F8-7439	31351127414	F8-5118	33316758260	F8-7145	33329058823	F8-7352
31331134096	F8-7439	31351129139	F8-5117	33316770454	F8-5300	33329058823	F8-7352S
31331134314	F8-7685	31351131621	F8-5119	33316770783	F8-5318	33329061946	F8-7352
3133-1135577	F8-7425	31351132786	F8-5119	33316770784	F8-5319	33329061946	F8-7352S
31331135582	F8-5506	31351133738	F8-5115	33319059300	F8-5323	33331116442	F8-7014
31331137932	AK-735154	31351135805	F8-5114	33319059301	F8-5324	33331118569	F8-7014
31331137932	AK-735447	31356761591	F8-7917	33321090102	F8-7602	33501094977	F8-6782
31331137932	F8-7727	31356765574	F8-7931	33321090504	F8-5299	33503404974	AK-735178
3133-1139436	F8-7425	32106765782	LM-10100S	33321090504	F8-7353	33503411995	AK-735178
31331139437	F8-7440	32106785993	LM-10100S	33321090745	F8-7602	33503411995	AK-735421



BMW	
33503413925	F8-7741
33503450542	F8-7741
33504035929	F8-5030
33506763137	AK-735231
33506771737	F8-7724
33506771738	F8-7723
33506773628	AK-735423
33506773628	F8-7702
33521090309	F8-5865
33521091238	F8-5774
33521091710	F8-5775
33521091711	F8-5866
33521092362	F8-5030
33521092943	AK-735448
33521092943	F8-7728
33521093416	F8-5930
33521094091	F8-5774
33521094977	F8-6782
33521097272	F8-6085
33521125554	F8-5417
33521128819	F8-5417
33521132088	F8-5932
33521132270	F8-5416
33521136283	AK-735126
33521136283	F8-7684
3352-1136283	AK-735126
33521137972	F8-5030
33522229854	F8-6781
33526753810	F8-7604
33526764268	AK-735173
33526769744	F8-7604
33526773669	F8-6085
33526776132	F8-7488
33526779611	F8-7604
33531091031	AK-735447
33531091031	F8-6087
33531093094	F8-7726
33531094065	F8-7730
33531094724	AK-735448
33531094724	F8-7729
33531135624	F8-5867
33531136395	AK-735126
33531136395	F8-5963
3353-1136395	AK-735126
33531138109	F8-7700
33531507254	AK-735229
33531507254	AK-735231
33531518391	AK-735229
33534035353	F8-7709
33536751030	AK-735171
33536751030	F8-6086
33536758088	AK-735176

BMW	
3353-6758088	AK-735176
33536758557	AK-735176
3353-6758557	AK-735176
33536761027	AK-735174
33536761027	F8-7335
33536764407	AK-735426
33536767334	AK-735421
33536767334	F8-7725
33536767335	F8-7709
33536768667	AK-735423
33536768667	F8-7702
33536771381	AK-735427
33536771381	F8-7706
33551093663	F8-7939
33551131155	F8-5689
33551138104	F8-7976
3411973	AK-735414
37121129716	F8-7731
4466271	F5-1051
6750892	F8-6543
6751594	AK-735413
6757046	F8-6544
6778544	AK-735415
6778544	F8-6088

CHEVROLET	
13251764	F8-7621
90250348	F8-7121
90250434	F8-7121
90250437	F8-7123
9209466	F8-7857
9209466	F8-7857S
93743440	F5-1001
96129656	F8-7121
96225638	F8-7368
96242859	F8-8218
96297803	F8-8218
96297804	F8-8218
96300082	AK-735317
96300220	F8-8218
96311832	F8-8217
96322618	F8-8013
96378346	F8-8219
96380586	F8-7986
96380613	F8-6585
96391856	F8-7937
96403109	AK-735318
96434540	F8-8220
96444919	F8-7117
96444920	F8-7118
96456713	F8-7369
96474040	F8-8220
96474041	F8-8221

CHEVROLET	
96494604	AK-735316
96535006	AK-735315
96535008	AK-735315
96535087	F8-8015
96535088	F8-8014
96535162	AK-735316
96549923	F8-8220
96549925	AK-735317
96561749	AK-735318
96653381	F8-8014
96839848	F8-8220

CHRYSLER	
04861513AC	F5-1107
04861513AD	F5-1107
05175811AA	F5-1126
053183490AA	F5-1089
4322620	F8-7356
4322760	F8-7356
4404976	F8-7356
4404977	F8-7356
4656012AB	F8-8228
4656012AC	F8-8228
4656447AC	AK-735322
4684005	F8-7356
4684006	F8-7356
4684442AB	AK-735323
4684643	F8-7356
4684678	F8-7356
4684756AC	AK-735324
4694932AA	AK-735323
4861513AB	F5-1107
4891737AB	F5-1078
5 3034049AA	F5-1089
5117591AA	F5-1019
52087635	AK-735320
52087636AC	AK-735320
52088705AE	AK-735319
5272223AC	AK-735321
53013579AA	F5-1106
A252C5221C	F5-1090

CITROËN	
0515 Q8	F8-7861
0515 R5	F8-7862
0515.H3	F8-6395
0515.H6	F8-7084
0515.J3	F8-7643
0515.K1	F8-6394
0515.K4	F8-7079
0515.K6	F8-7083
0515.N0	F8-6394
0515.P1	F8-6394
0515.P5	F8-6394

CITROËN	
0515.R0	F8-7082
0515.R4	F8-7644
0515.R8	F8-6394
0515.S1	F8-6394
0515.S2	F8-7874
0515.T1	F8-6571
0515.T3	F8-7645
0515.T4	F8-7081
0515.V4	F8-7082
0515.V8	F8-7082
0515K4	F8-7863
0515P2	F8-5636
0515Q6	F8-5659
0515R2	F8-5660
0515R9	F8-5660
0515S4	F8-5660
1305782080	F8-5092
1307021080	F8-5936
1316735080S	F8-6155
1316735080S1	F8-6153
1316736080S	F8-6154
1318825080	F8-3014
1318825080	F8-7164
141480	F8-6587
1607114880	F8-7790
1608945780	F8-7791
1608947980	F8-7791
1608948080	F8-7791
1806.28	F8-8167
1806.59	F8-8141
1806.69	F8-8169
1806.84	F8-8141
1806.95	F8-6612
1806.96	F8-8141
180628	F8-8167
180659	F8-8141
180669	F8-8169
180684	F8-8141
180696	F8-8141
1807.45	F8-6854
1809.21	F8-6236
1809.22	F8-6237
1809.28	F8-7011
1809.30	F8-8184
1809.33	F8-8184
180904	F8-5375
180906	F8-5375
180916	F8-5026
180930	F8-8184
180933	F8-8184
1827.08	F8-6857
1827.14	F8-6857



CITROËN		CITROËN		CITROËN		CITROËN	
1827.17	F8-6520	3523.23	F8-5072	4331968	G9-504	503527	F8-6296
1827.19	F8-6888	3523.29	G9-523	5031.25	F8-5353	503527	F8-6297
1827.22	F8-6857	3523.29	G9-523S	5031.53	F8-5518	503527	F8-6302
1827.26	F8-6857	3523.43	F8-5150	5031.54	F8-5519	503529	F8-3014
1827.33	F8-6897	3523.49	F8-5078	5031.55	F8-5353	503529	F8-7164
182710	F8-5569	3523.50	G9-556	5031.63	F8-5508	503530	F8-3023
1839.46	F8-6538	3523.51	G9-555	5031.70	F8-5354	503530	F8-6306
1843.61	F8-6509	3523.52	F8-5251	5031.71	F8-5353	503530	F8-7154
1843.80	F8-6903	3523.53	F8-6143	5031.72	F8-5517	503538	F8-3014
1843.84	F8-6902	3523.59	F8-5248	5031.73	F8-5516	503538	F8-6304
1843.93	F8-6921	3523.62	F8-5248	5031.77	F8-6058	503538	F8-7164
1843.95	F8-5556	3523.75	F8-5248	503125	F8-7154	503539	F8-3023
1843.97	F8-5558	3523.83	F8-5361	503153	F8-6293	503539	F8-6306
1843.98	F8-6496	3523.84	F8-7974	503154	F8-6292	503539	F8-7154
1843.99	F8-8199	3523.91	F8-6134	503155	F8-7154	503543	F8-3014
184373	F8-5358	3523.92	G9-699	503166	F8-6304	503545	F8-3014
184399	F8-8199	3523.93	F8-6115	503170	F8-6306	503547	F8-3023
1844.17	F8-5558	3523.93	F8-6452	503171	F8-7154	503547	F8-6306
1844.36	F8-6500	3523.94	F8-6114	503172	F8-6297	503547	F8-7154
1844.41	F8-6496	3523.98	F8-5629	503173	F8-6296	503552	F8-6266
1844.46	F8-6891	3523.99	F8-6537	503174	F8-6563	503555	F8-3014
1844.47	F8-5357	3523.AA	F8-6535	503177	F8-6302	503555	F8-6304
1844.54	F8-6904	3523.AP	F8-6773	503179	F8-7468	503555	F8-7164
1844.58	F8-6898	3523.AR	F8-7912	503198	AK-735416	503557	F8-6266
1844.66	F8-6898	352314	G9-521	5033.26	F8-6064	5035-57	F8-7171
1844.68	F8-6500	352331	G9-525	5033.66	F8-7672	503558	F8-3012
1844.93	F8-8149	352351	G9-558	5033.70	F8-7585	503563	F8-3012
1844.C0	F8-8202	352364	F8-5251	5033.71	F8-6564	5035C2	F8-6266
184425	F8-5568	352381	F8-6171	5033.72	F8-7587	503720	F8-5508
184436	F8-6500	352382	F8-6172	5033.75	F8-6562	503733	F8-5520
184437	F8-5358	352393	F8-6115	5033.84	AK-735129	503733	F8-7154
184438	F8-6487	352393	F8-6452	503339	AK-735091	5038.08	F8-5519
184442	F8-5358	3525.05	F8-6452	503339	F8-5936	5038.15	F8-5518
184468	F8-6500	352505	F8-6452	503370	AK-735068	5038.16	F8-5622
184472	F8-6487	3561.08	F8-5084	503371	F8-6564	5038.17	F8-5621
184493	F8-8149	3740.39	F8-7197	503372	AK-735129	5038.18	F8-5354
1844C0	F8-8202	3740.39	G8-197	503382	F8-7711	5038.19	F8-5353
1846.65	F8-6918	4018.A5	LM-10018S	503384	AK-735129	5038.21	F8-5516
1846.C1	F8-6712	4066.16	LM-10054S	503396	AK-735416	5038.23	F8-5517
328769	F8-5356	4066.20	LM-10004S	5033E7	F8-7659	5038.24	F8-5516
3502.77	F8-6276	4066.22	LM-10039S	503515	F8-6293	5038.28	F8-8066
3502.77	G8-276-501	4066.30	LM-10072S	503517	F8-3013	5038.29	F8-8067
3502.77	G8-276-502	4066.31	LM-10018S	503518	F8-5520	5038.41	F8-5354
350430	F8-6586	4066.32	LM-10014S	503519	F8-3012	5038.41	F8-8066
3520.G9S	F8-6155	4066.34	LM-10051S	503523	F8-3012	5038.42	F8-5353
3520.H5S1	F8-5355	4066.35	LM-10018S	503523	F8-6293	5038.46	F8-6058
3520.HSS1	F8-5355	4066.41	LM-10022S	503523	F8-6296	5038.50	F8-5518
3520.Q2	F8-6587	4066.43	LM-10058S	503523	F8-6297	5038.52	F8-5519
3520G9S1	F8-6153	4066.50	LM-10047S	503523	F8-6302	5038.62	F8-5516
3521.C9S	F8-6154	4066.57	LM-10040S	503527	F8-3012	5038.72	F8-5354
3521.L3	F8-6587	4066.73	LM-10040S	503527	F8-6292	5038.72	F8-8066
3523.20	G9-520	4066.82	LM-10040S	503527	F8-6293	5038.74	F8-5353



CITROËN		CITROËN		CITROËN		CITROËN	
5038.74	F8-8067	5038J7	F8-7429	5131.96	F8-6276	5154.08	G8-272
5038.76	F8-5517	5038J8	F8-7428	5131.96	G8-248	5154.09	F8-6272
5038.78	F8-5516	505443	F8-7490	5131.96	G8-276-501	5154.09	G8-272
5038.85	F8-6058	5094.59	F8-6096	5131.96	G8-276-502	5154.10	F8-6272
5038.87	F8-6610	5094.77	F8-6128	5131.A4	F8-6591	5154.10	G8-272
5038.89	F8-6611	5094.91	F8-6589	5131.A6	F8-6277	5154.11	F8-6274
5038.A3	F8-6611	5094.A6	F8-6589	5131.A6	F8-7197	5154.11	F8-6275
5038.A4	F8-6610	509465	F8-5213	5131.A6	G8-197	5154.11	G8-274
5038.C9	F8-6611	509466	F8-6129	5131.A6	G8-277	5154.11	G8-275
5038.E3	F8-6610	509469	F8-5092	5131.F6	F8-7790	5166.63	F8-7589
5038.F7	F8-6058	509479	F8-7943	513146	F8-5870	5166.67	F8-7586
5038.G0	F8-6058	509483	F8-6595	5131A5	F8-6592	5166.73	F8-7590
503808	F8-6292	509488	F8-6594	5132.49	F8-6272	516673	F8-7590
503816	F8-6304	509496	F8-6590	5132.49	G8-272	516698	F8-7491
503817	F8-7164	509497	F8-6588	5132.55	F8-6274	5174.05	F8-6275
503818	F8-6306	5102.CA	F8-7791	5132.55	G8-274	5174.05	F8-6277
503819	F8-7154	5102.EY	F8-7791	5132.56	F8-6275	5174.05	G8-275
503821	F8-5364	5102.FA	F8-7791	5132.56	G8-275	5174.05	G8-277
503821	F8-6296	5102.FC	F8-7791	5132.60	F8-6276	5174.07	F8-6275
503823	F8-6297	5102.P8	F8-7791	5132.60	G8-276-501	5174.07	F8-6277
503824	F8-5364	5102.Q2	F8-7791	5132.60	G8-276-502	5174.07	G8-275
503824	F8-6296	5102.Q4	F8-7791	5132.62	F8-6272	5174.07	G8-277
503828	F8-7468	5102.T2	F8-7791	5132.62	G8-272	5174.08	F8-6248
503841	F8-6306	5102.T3	F8-7791	5132.65	F8-6272	5174.08	G8-248
503842	F8-7154	5102.T4	F8-7791	5132.65	F8-6277	5176.17	F8-6272
503846	F8-6302	5102.T5	F8-7791	5132.65	F8-7197	5176.17	G8-272
503849	F8-6515	5102.T6	F8-7791	5132.65	G8-197	5179.14	F8-6248
503850	F8-6293	5102.T7	F8-7791	5132.65	G8-272	5179.14	F8-6275
503852	F8-6292	5102.T8	F8-7791	5132.65	G8-277	5179.14	F8-6277
503862	F8-5364	5102.T9	F8-7791	5132.66	F8-6248	5179.14	G8-248
503862	F8-6296	5131.45	F8-6272	5132.66	G8-248	5179.14	G8-275
503868	F8-5622	5131.45	G8-272	5132.72	F8-6277	5179.14	G8-277
503868	F8-6304	5131.47	F8-5852	5132.72	F8-7197	521020	F8-5612
503872	F8-6306	5131.48	F8-6276	5132.72	G8-197	521034	AK-735417
503874	F8-7154	5131.48	G8-276-501	5132.72	G8-277	5254.35	AK-735129
503876	F8-6297	5131.48	G8-276-502	5132.73	F8-6276	525419	AK-735091
503878	F8-6296	5131.49	F8-6248	5132.73	G8-276-501	525431	AK-735068
503885	F8-6302	5131.49	F8-6276	5132.73	G8-276-502	525435	AK-735129
503887	F8-7467	5131.49	G8-248	5133.22	F8-6274	525442	AK-735438
503891	F8-6515	5131.49	G8-276-501	5133.22	F8-6275	525448	F8-7660
5038A4	F8-7467	5131.49	G8-276-502	5133.22	G8-274	75472408	G8-556
5038C1	F8-7170	5131.63	F8-5799	5133.22	G8-275	9150018980	G9-521
5038C1	F8-7171	5131.64	F8-6274	5142.34	F8-7169	91504248	G9-521
5038E2	F8-7468	5131.64	F8-6275	514851	G8-276-502	9151018980	G9-523
5038E3	F8-7467	5131.64	G8-274	514858	G8-274	9151018980	G9-523S
5038F3	F8-7467	5131.64	G8-275	514858	G8-275	91510633	F8-6293
5038F4	F8-7468	5131.69	F8-5352	514883	G8-276-501	91510633	F8-6296
5038F5	F8-6516	5131.70	F8-5351	514883	G8-276-502	91510633	F8-6297
5038F6	F8-7170	5131.71	F8-5363	514898	G8-276-502	91510633	F8-6302
5038F6	F8-7171	5131.72	F8-5897	515261	F8-5871	9151063380	F8-6292
5038G7	F8-7428	5131.73	F8-5898	515262	F8-6176	9151063380	F8-6293
5038G8	F8-7429	5131.96	F8-6248	5154.08	F8-6272	9151063380	F8-6296



CITROËN		CITROËN		DACIA		DAEWOO	
9151063380	F8-6297	96147478	F8-5352	8200592642	F8-7746	96380586	F8-7986
9151063380	F8-6302	96148480	F8-6143	8200651172	F8-3032	96391856	F8-7937
91510923	LM-10004S	9615871780	F8-5062	8200651172	F8-6339	96403109	AK-735318
91515653	F8-5078	96158746	F8-6129	8200757150	F8-6339	96444919	F8-7117
91535412	F8-5558	96159157	F8-5614	8200757150	F8-6596	96444920	F8-7118
9451076780	LM-10014S	9621916980	F8-7589	8200808455	F8-7450	96456713	F8-7369
9503035580	F8-6274	9625137580	F8-7672	8200839121	F8-8070	96474041	F8-8221
9503035580	F8-6275	9627434580	F8-6274	8200876298	F8-6710	96494604	AK-735316
9503035580	G8-275	9636181080	F8-5629	<b>DAEWOO</b>		96535006	AK-735315
95205626	F8-5557	9636924480	F8-6394	02875013	F8-5333	96535008	AK-735315
9556384280	F8-6272	9638747080	F8-7672	0344402	F8-5710	96535087	F8-8015
9556384280	G8-272	9640877080	F8-6535	0344509	F8-3059	96535088	F8-8014
95598362	G9-610	9646179980	F8-7586	0350153	F8-5333	96535162	AK-735316
95603308	G9-556	9646251480	F8-7587	0352335	G9-592	96549925	AK-735317
95603346	G9-610	9646254781	F8-6515	0352349	G9-591	96561749	AK-735318
95603783	F8-5519	9648620380	F8-7711	0402642	F8-3060	96653351	F8-8016
95603783	F8-6292	9650485180	F8-7590	211242	F5-1001	96653381	F8-8014
95619159	G8-540	9650653380	F8-6394	26024585	LM-10045S	<b>DAIHATSU</b>	
9563609180	F8-6275	9653771880	F8-6394	26024585	M-822300	4833187204	AK-735325
9563609180	G8-275	9655703580	F8-6394	26024585	MK-822300	4834187211	AK-735326
96 089 104	F8-7980	9677608180	F8-8112	2875013	F8-5333	<b>DODGE</b>	
96030147	F8-6857	97521102	F8-5555	344509	F8-3059	053183490AA	F5-1089
96038337	F8-6927	<b>DACIA</b>		344518	F8-3025	5 3034049AA	F5-1089
96048196	F8-6857	112107695R	F8-6711	402645	F8-4102	5103955AB	F8-5752
96050338	F8-6143	6001025850	F8-3032	90090811	M-822300	<b>FIAT</b>	
96051355	F8-5213	6001025850	F8-6339	90090811	MK-822300	0004288726	G9-506
96051391	F8-5213	6001547140	F8-6601	90090811	MK-822300	04333710	F8-5870
96054797	F8-5799	6001547499	F8-6339	90121275	F8-3024	04400895	F8-3017
96061864	F8-5363	6001547499	F8-6596	90125889	F8-5710	04400895	F8-6381
96064489	F8-6792	6001547607	LM-10032S	90184756	F8-3059	04466980	F8-5612
96070064	F8-5312	6001547893	F8-6711	90189050	F8-3060	0515P2	F8-5636
96083570	F8-5271	6001548160	F8-6600	90235040	G9-592	05960254	F8-5563
96090345	F8-5516	6001548402	F8-7900	90235042	G9-591	05968311	F8-5515
96090345	F8-6296	6001548403	F8-6710	90250348	F8-7121	07544738	G9-512
96090346	F8-5517	6001549205	F8-8157	90250434	F8-7121	07601502	F8-3015
96090346	F8-6297	6001549290	F8-7900	90250437	F8-7123	07602150	F8-5956
96096727	G9-520	6001549989	F8-6597	90345195	M-822300	07603476	F8-5083
96104506	F8-5347	6040002245	F8-7977	90345195	MK-822300	07610157	F8-5641
96106474	G9-558	7700110616	F5-1061	90345195	MK-822300	07635775	F8-5957
96113432	G9-556	7700415728	F8-7450	90374844	F8-3025	07635775	F8-5958
96121571	F8-6857	7700800107	F8-3032	926614001	F8-3025	07635775S1	F8-5958
9612314180	F8-6276	7700800107	F8-6339	96 380 613	F8-6585	07674701	G9-508
9612314180	G8-276-501	7701477689	F5-1029	96129656	F8-7121	07760424	F8-5094
9612314180	G8-276-502	82 00 839 121	F8-8070	96185973	G9-591	07762158	F8-5937
9612314280	F8-6276	8200117837	F8-6598	96225638	F8-7368	07775940	F8-5858
9612314280	G8-276-501	8200297939	F8-6599	96298000	F8-8186	1300507080	F8-6115
9612314280	G8-276-502	8200307941	F8-6339	96300082	AK-735317	1302443080	F8-3023
96133255	G9-610	8200307941	F8-6596	96308002	F8-8187	1302443080	F8-6306
96140317	F8-5518	8200338372	F8-7746	96311832	F8-8217	1302443080	F8-7154
96140317	F8-6293	8200395661	F8-6600	96322618	F8-8013	1303672080	F8-3014
9614031780	F8-5518	8200557552	F8-7450	96335966	G9-591	1303672080	F8-6291
9614031780	F8-6293	8200575641	F8-8157	96378346	F8-8219	1303672080	F8-6304





FIAT		FIAT		FIAT		FIAT	
1304640080	F8-5897	1331938080-PART	F8-6452	1479759080	F8-5871	46545661	F8-6450
1304641080	F8-5898	1331938080-PART	F8-6773	1484063080	F8-6857	46545661S	F8-6052
1305782080	F8-5092	1331939080-PART	F8-6114	182710	F8-5569	46545661S1	F8-6053
1307021080	F8-5936	1331939080-PART	F8-6773	3520.G9S	F8-6155	46550122	AK-735348
1307241080	F8-5354	1331940080-PART	F8-6114	3520.G9S1	F8-6153	46550123	AK-735349
1307241080	F8-6306	1331940080-PART	F8-6452	3521.C9S	F8-6154	46551376	F8-5276
1307241080	F8-8066	1331940080-PART	F8-6773	352393	F8-6115	46551377	F8-5277
1307242080	F8-5353	1338373080	F8-6773	352393	F8-6452	46551732	F8-6450
1307242080	F8-7154	1339464080-PART	F8-6773	4331968	G9-504	46551790	F8-6450
1307242080	F8-8067	1339465080-PART	F8-6452	4333710	F8-5870	46742883	F8-6393
1307906080	F8-6891	1339465080-PART	F8-6773	4339248	F8-5084	46742884	F8-7087
1307907080	F8-6888	1339466080-PART	F8-6773	4390179	F8-3013	46746544	F8-6286
1307908080	F8-6520	1339467080-PART	F8-6452	4400895	F8-3017	46746546	F8-6288
1308694080	F8-6114	1339467080-PART	F8-6773	4400895	F8-5958	46746548	F8-6287
1310575080	F8-6918	1343631080	F8-6612	4400895	F8-6381	46748578	F8-6244
1311716080	AK-735351	1344335080	F8-6613	4400905	F8-5957	46748579	F8-6245
1311716080	AK-735381	1346384080-PART	F8-6155	4433964	F8-6928	46749600	F8-6896
1311930080	F8-5622	1346385080-PART	F8-6154	4433965	F8-6912	46750910	F8-6561
1311930080	F8-6304	1348993080	F8-6614	4456819	F8-6509	46759737	F8-6607
1311931080	F8-5621	1350009080	F8-7791	4466980	F8-5612	46760673	F8-6367
1311931080	F8-7164	1350011080	F8-7791	46 307 840	MK-810160	46760674	F8-7158
1312317080	F8-6439	1350080080	F8-7791	46404169	F8-5938	46761804	F8-6608
1316735080	F8-6153	1350788080	F8-6611	46404169	F8-7595	46765087	F8-6934
1316735080	F8-6155	1350788080	F8-7468	46413115	F8-7863	46766963	F8-6604
1316735080S	F8-6155	1350789080	F8-6610	46414183	F8-5514	46767261	F8-6603
1316735080S1	F8-6153	1350789080	F8-7467	46414184	F8-5513	46770939	F8-7085
1316736080	F8-6154	1351263080	F8-7790	46421522	F8-5273	46773884	F8-5938
1316736080S	F8-6154	1351268080	F8-7791	46431619	F8-5414	46773884	F8-7595
1318573080	F8-3023	1352887080	F8-6612	46439876	F8-7012	46773884SK	F8-5938
1318573080	F8-6306	1352888080	F8-6712	46441617	F5-1108	46773925	F8-6609
1318573080	F8-7154	1355179080	F8-3023	46445246	F8-5600	46780491	F8-6393
1318825080	F8-3014	1355179080	F8-7468	46450461	F8-6633	46786245	F8-6521
1318825080	F8-6291	1355336080	F8-7791	46454061	F8-5274	46809886	F8-7085
13207 56080	F8-6452	1355337080	F8-7791	46454062	F8-5275	46819147	F8-7086
1320755080-PART	F8-6114	1355403080	F8-7791	46464273	F8-7430	46820471	F8-6605
1320756080-PART	F8-6114	1355466080	F8-7791	46464298	AK-735443	46830162	F8-6606
1320756080SK	F8-6115	1355467080	F8-7791	46466619	AK-735353	46844208	F8-8086
1320786080-PART	F8-6114	1355468080	F8-7791	46466619	AK-735443	50003871	F8-6324
1320787080-PART	F8-6114	1356977080	F8-7791	46469709	F8-5600	500332292	F8-7080
1323165080	F8-5354	1356978080	F8-7791	46470781	AK-735347	500332293	F8-7081
1323165080	F8-6306	1357567080	F8-7791	46473041	F8-6602	5033.39	F8-5936
1323165080	F8-8066	1361231080	F8-7791	46473054	AK-735353	503372	AK-735129
1323166080	F8-5353	1365406080	F8-7791	46476755	F8-5864	503382	AK-735129
1323166080	F8-7154	1365407080	F8-7791	46514433	F8-6932	503538	F8-3014
1323166080	F8-8067	1365409080	F8-7791	46516096	F8-7648	504099920	F8-7081
1329669080	F8-3014	1369384080	F8-7790	46528871	F8-8086	50521707	F8-7421
1329669080	F8-6291	1369842080	F8-7791	46529067	F8-7596	50700443	F8-5264
1329669080	F8-6304	1369843080	F8-7791	46531017	AK-735350	50700778	F8-5265
1329669080	F8-7164	1369844080	F8-7791	46531017	F8-7593	50700871	F8-6264
1331937080-PART	F8-6114	1400257380	AK-735351	46536244	F8-6291	50700871	F8-6735
1331937080-PART	F8-6773	1400257380	AK-735381	46541086	F8-6560	50701077	AK-735345
1331938080-PART	F8-6114	1477403080	F8-7863	46545660	F8-6450	50701077	AK-735377



FIAT		FIAT		FIAT		FIAT	
50701077	F8-7594	51839975	F8-7429	71742733	F8-6448	7692557	F8-6791
50701328	F8-7592	525435	AK-735129	71747796	F8-7087	7708182	F8-6919
50702206	F8-6288	55182506	F8-7647	71768151	F8-6449	7708183	F8-6920
50702841	F8-6290	55184474	F8-7087	71768163	F8-6449	77362558	F5-1046
50702892	F8-7594	55185409	F8-6393	7537167	F8-5927	77362721	F5-1045
50703128	F8-6247	55187707	F8-7087	7543418	F8-6893	77363468	F5-1048
50703128-PART	F8-6246	55190424	F8-6393	7544643	F8-6911	77363948	F5-1098
50703129	F8-6247	55190581	F8-7085	7544738	G9-512	77363954	F5-1037
50703129-PART	F8-6246	55196301	F8-6393	7550024	F8-6902	77364082	F5-1125
50703131	F8-7597	55200498	F8-7086	7550361	F8-6955	77364148	F5-1067
50703231-PART	F8-6442	55215574	F8-7087	7559908	F8-5515	77364723	F5-1041
50703232-PART	F8-6442	55700431	F8-6618	7559908	F8-6381	77364725	F5-1098
50708823-PART	F8-6450	55700434	F8-6619	7563151	F8-5642	77364797	F5-1148
50708824-PART	F8-6450	55700435	F8-6622	7567590	F8-5515	77365271	F5-1147
50709096	AK-735338	55700440	F8-6616	7567590	F8-6381	7737417	F8-7013
5094.69	F8-5092	55700441	F8-6620	7569283	F8-5618	7743792	F8-6602
5131.46	F8-5870	55700442	F8-6617	7583185	F8-6342	7748666	F8-6917
51707691	F8-6560	55700751	F8-7995	7583242	LM-10053S	7750990	F8-6731
51748652-PART	F8-6446	55700767	AK-735342	7583243	LM-10043S	7755436	F8-6496
51748653-PART	F8-6446	55700767	AK-735343	7587675	F8-6894	7756218	F8-7020
51755688	F8-7329	55700767	F8-7663	7589253	F8-6937	7760424	F8-5094
51755688	F8-7330	55701429	AK-735344	7594993	F8-6895	7762158	F8-5937
51755689	F8-7172	55701796	F8-7422	7599485	AK-735337	7764084	F8-6939
51755689	F8-7330	55701901	F8-7424	7599694	F8-6921	7764414	F8-6941
51755690	AK-735342	55701902	F8-7423	7601064	G9-530	7765921	F8-6940
51760171	F8-6605	55702833	F8-6623	7601065	G9-532	7773844	F8-7012
51761609	F8-6615	55702836	F8-6621	7601068	G9-531	7775343	G9-612
51775545	AK-735343	5927292	G9-533	7601260	G9-506	7775343L	G9-612
51780079	F8-7421	5927293	G9-534	7601500	F8-5514	7775344	G9-584
51780702	F8-7422	5934176	F8-6903	7601502	F8-3015	7775344R	G9-584
51782560	F8-6624	5937315	F8-6935	7601504	F8-5513	7775940	F8-5858
51796607	AK-735346	5960254	F8-5563	7602150	F8-5956	7776485	F8-5600
51796607	AK-735378	5968311	F8-5515	7603476	F8-5083	7778028	F8-7648
51797478	AK-735339	5968311	F8-6381	7610157	F8-5641	7778563	F8-6936
51799110	F8-6630	5974777	F8-6931	7610541	F8-6885	7778950	F8-6264
51804747	F8-7429	6013887857	F5-1108	7613889	F8-6893	7782435	F8-6631
51804748	F8-7428	60507954	F8-5603	7629021	F8-6886	7782710	AK-735341
51805433	F8-6713	60674507	AK-735380	7635775	F8-5957	7784313	F8-5415
51807101	F8-7427	60679760	AK-735380	7635775	F8-5958	7792020	F8-6632
51811829	F8-7484	60805971	F8-6914	7635775S1	F8-5958	82335609	F8-3021
51813029	F8-6629	60806398	F8-3015	7644686	F8-6914	82351974	F8-3021
51813225	F8-7421	60811372	F8-5514	7663999	F8-6496	82382210	F8-3021
51813603	F8-6628	60811373	F8-5513	7664079	F8-7173	82388242	F8-5640
51813605	F8-6625	60813084	F8-6632	7667087	F8-5598	82398815	F8-5591
51813606	F8-6626	60813790	F8-7863	7667850	F8-6887	82398818	F8-5592
51813607	F8-6627	60815929	F8-7087	7670108	F8-7029	82406929	F8-5592
51827031	F8-7594	71728498	F8-6393	7673581	G9-533	82430666	F8-5603
51830518	F8-7435	71740107	F8-6447	7673582	G9-534	82491440	F8-6367
51831016	F8-7421	71742685	AK-735352	7674701	G9-508	82491441	F8-7158
51839218-PART	F8-6442	71742686	AK-735352	7676967	G9-533	83616850	F5-1108
51839219-PART	F8-6442	71742731	F8-6449	7683363	F8-5514	92332568	AK-735340
51839931	F8-7428	71742732	F8-6449	7683364	F8-5513	93501487-PART	F8-6155



FIAT		FORD		FORD		FORD	
93501488-PART	F8-6154	1 639 562	F8-7594	1061670	F8-6638	1121510	LM-10023S
9404066418	LM-10022S	1 040 404	F8-6503	1061720	F8-7686	1122893	F8-5408
9405031789	F8-7467	1 661 786	F8-6492	1061721	F8-6318	1122893	F8-7102
9405031799	F8-7468	1000445	G9-585	1061721	F8-6511	1124418	F8-7903
9405035439	F8-6291	1002513	F8-5413	1061722	F8-6066	1124891	F8-7650
9405038689	F8-5622	1002513	F8-6312	1061722	F8-6318	1128725	F8-6137
9405038689	F8-6304	1003609	F8-5328	1063372	G9-663	1131911	F8-7649
9467510480	F8-5660	1003914	F8-5410	1064069	F8-6060	1139706	F8-6559
9604338880	F8-5569	1004011	G9-663	1064722	F8-6066	1143413	F8-6399
9606121080	F8-5026	1006033	F8-7031	1064722	F8-6318	1145272	F8-6034
96089 38980	F8-5643	1009649	F8-6703	1067918	F8-6016	1146129	F8-7581
9612157380	F8-6857	1010037	G9-662	1067976	F8-6732	1146151	F8-7683
9613305380	F8-6236	1010125	F8-5412	1070177	F8-6754	1146152	F8-6317
9616121080	F8-5026	1010125	F8-6312	1073155	F8-6555	1146153	F8-7431
9618184180	F8-6507	1010127	F8-6556	1073217	F8-5330	1150967	F8-6559
9624128180	F8-6857	1011898	F8-5995	1073249	F8-6732	1151 392	F8-6399
9630647280	F8-5660	1012814	LM-10007S	1073486	F8-6061	1151390	AK-735084
9631575180	F8-8167	1013794	F8-5412	1074282	F8-5136	1151394	F8-7650
9635939980	F8-8149	1013794	F8-6312	1078730	F8-6262	1151926	F8-7431
9641548980	F8-5636	1014654	G9-663	1078730	F8-6308	1151926	F8-8213
9641884980	F8-8167	1014899	F8-5411	1078730	F8-6316	1152852	F8-7934
9643354180	F8-7861	1015817	F8-7031	1087177	F8-6066	1152896	F8-8200
9651770980	F8-5660	1016439	F8-6074	1087177	F8-6318	1198235	F8-6317
9654961080	F8-7645	1021267	F8-8115	1089033	F8-8150	1198235	F8-8213
9655703580	F8-6394	1021268	F8-6926	1090422	F8-6555	1203103	F8-7431
9938779	LM-10060S	1023058	F8-5136	1094591	F8-7030	1205834	F8-7455
9941077	LM-10018S	1023326	AK-735033	1097914	F8-7031	1205835	F8-7455
9943623	LM-10018S	1023326	F8-8121	1097920	F8-7031	1212807-PART	F8-6159
9946982	LM-10018S	1023332	F8-6262	1099547	F8-8115	1212807-PART	F8-6160
9947369	LM-10008S	1023332	F8-6308	1102416	F8-6754	1212808-PART	F8-6159
9947369	LM-10025S	1023332	F8-6316	1102507	F8-6756	1212808-PART	F8-6160
9948513	F5-1123	1023587	F8-5410	1102592	F8-3039	1221058	F8-6558
9949129	F5-1123	1024959	F8-7031	1102771	F8-5328	1223835	F8-6268
9949580	F5-1013	1024960	F8-7031	1103725	F8-6262	1223835	F8-7156
9949627	F5-1020	1032120	F8-6958	1103725	F8-6308	1226637	F8-7650
9949627	F5-1039	1032635	F8-6756	1103725	F8-6316	1226638	F8-7650
9951162	F5-1005	1033283	F8-6553	1104037	F8-6066	1231959	F8-7861
9951269	F5-1123	1035929	G9-586	1104037	F8-6318	1233950	F8-6357
		1039001	F8-5409	1105883	AK-735077	1250820	F8-6268
		1040404	F8-6503	1105883	AK-735084	1250820	F8-7156
		1041979	F8-5971	1106734	F5-1007	1250824	F8-8140
		1044571	G9-664	1106874	F8-6066	1251053	AK-735405
		1051724	F8-6262	1106874	F8-6318	1253168	F8-7431
		1051724	F8-6308	1111753	F8-6558	1254213	AK-735201
		1051724	F8-6316	1112025	F8-8165	1254213	AK-735431
		1055191	G9-662	1115132	F8-6066	1254213	F8-7683
		1056804	F8-7010	1115132	F8-6318	1254219	AK-735201
		1060402	F8-6926	1115177	F8-6510	1254220	AK-735431
		1061205	F8-7030	1115177	F8-7102	1254220	F8-7581
		1061335	F8-6756	1117734	F8-5408	1255350	F8-6268
		1061570	F8-6015	1118741	F8-7032	1255350	F8-7156
		1061658	F8-6355	1121510	F8-5051	1300459	F8-6357
FORD							
0515P2	F8-5636						
1 008 225	MK-810160						
1 008 228	MK-810160						
1 035 515	F8-5328						
1 079 188	F8-6387						
1 100 051	F8-6387						
1 133 019	F8-6472						
1 139 257	F8-6475						
1 387 095	F8-6571						
1 533 836	F8-7878						
1 566 829	F8-7878						
1 566 838	F8-7877						
1 566 841	F8-7878						



FORD		FORD		FORD		FORD	
1303625	F8-7455	1404977	F8-6640	1619751	F8-7435	1S4Q6B319AF	F8-6399
1304124	F8-6638	1406414	F8-7606	1632679	G9-524	1S65-5K653-AA	F8-5329
1305329	AK-735194	1420044	F8-8140	1632769	G9-524	1S71 3K099 AD	F8-7102
1305329	AK-735196	1426699	F8-8001	1634900	F8-5080	1S71 3K155 AE	F8-7102
1305329	AK-735199	1437549	F8-8197	1634901	F8-5070	1S7118198AF	F8-7455
1305329	F8-7838	1441213	AK-735202	1638511	F8-6929	1S7118198AG	F8-7455
1305960	F8-6637	1441597	F8-7606	1652910	G9-500	1S7118198AH	F8-7455
1309147	AK-735197	1441597	F8-7608	1656752	G9-501	1S71-3K099-AD	F8-6510
1309151	AK-735198	1444281	F8-6357	1656752	G9-501S	1S715K817AC	F8-6641
1311416S1	F8-6157	1446481	AK-735196	1659588	F8-6356	1S715K818AC	F8-6640
1311416S2	F8-6158	1455693	AK-735199	1659588S	F8-6260	1S717M122CC	F8-8200
1315782	F8-6396	1457070	F5-1004	1661786	F8-6492	1S7Q6B319AB	F8-7650
1320605	F8-6210	1458447	AK-735200	1689147	F8-7432	1S7Q6B319AC	F8-7650
1320605	F8-7156	1464268	AK-735193	1691681	AK-735451	1S7Q6B319BA	F8-7650
1321003	AK-735195	1468902	AK-735194	1691681	F8-7480	1S7Q6B319BB	F8-7650
1322569	F8-6207	1469224	F8-7431	1692273	F8-6357	1S7W 3K155 AF	F8-7102
1323096	F8-6208	1469755	F5-1004	1695146	F8-8139	1S7W3K155AE	F8-5408
1323319	F8-6355	1474352	AK-735192	1702970	F8-7853	1S7W3K155AF	F8-5408
1323599	F8-6210	1487654	G9-508	1702983	F8-7853	2C1U-10A352-AA	F5-1023
1323599	F8-7156	1488234	AK-735192	1710056	F8-7483	2S6118A116AD	F8-6358
1323629	AK-735197	1488960	F8-7456	1713375	AK-735451	2S613025AA	F8-7581
1329203	F8-7650	1490983	F8-6357	1713375	F8-7479	2S613025AE	F8-7581
1330706	F8-6358	1507181	F8-8075	1725158	F8-6357	2S61-3025-AE	AK-735431
1332075	F8-8078	1507182	F8-8074	1727140	F8-7651	2S61-3042-AH-PA	F8-6159
1332838	F8-8177	1508111	F8-6268	1734710	F8-7606	2S61-3042-AH-PA	F8-6160
1334230	F8-6210	1508111	F8-7156	1742604	F8-7433	2S61-3051-AH-PA	F8-6159
1334230	F8-7156	1510474	F8-7607	1745064	F8-6357	2S61-3051-AH-PA	F8-6160
1339553	F8-6210	1510474	F8-7608	1748942	F8-7651	2S613K036AA	F8-7683
1339553	F8-7156	1514543	AK-735435	1749593	F8-7855	2S613K036AB	F8-7683
1345657	F8-8197	1514543	F8-7489	1749991	F8-7853	2S61-3K036-AB	AK-735431
1349993	F8-7650	1514834	F8-7432	1749992	F8-7853	2S613K099AC	F8-6317
1351731	F8-7650	1514857	F8-7433	1749992	F8-7854	2S61-3K155-AD	F8-7431
1362651	F8-8078	1522138	F8-8140	1749992	F8-7855	2S61-3K155-AE	F8-7431
1365854	F8-6210	1526696	F8-8139	1750640	AK-735435	2S61-3K155-AF	F8-7431
1365854	F8-7156	1526778	F8-7432	1750640	F8-7489	2S716F012AD	F8-8177
1370318	F8-7583	1531648	AK-735435	1761001	F8-7606	3240198	G9-522
1370874	F8-8140	1533046	F8-8140	1763854	F8-7456	3395459	F5-1040
1377259	F8-7606	1535299	F8-7434	1775521	F8-7896	3405806	F8-7438
1377471	F8-6210	1539863	F8-7607	1808435	F8-7609	357412331A	F8-1034
1377471	F8-7156	1539863	F8-7608	1865033	F8-7877	357412331AS	F8-1034S
1377612	F8-6210	1543750	F8-8196	1865034	F8-7878	3736028	F8-6118
1377612	F8-7156	1547323	F8-7433	1883046	F8-8078	3736028S1	F8-6118
1377929	F8-7609	1548182	F8-7435	1883048	F8-8075	3904122	LM-10034S
1377973	F8-7456	1553893	F8-7435	1888630	F8-8074	3M21-6B320-AA	F8-6396
1379766	F8-7651	1567937	F8-8197	1C1518183AA	F8-6164	3M51-18A116-AA	F8-6357
1381836	F8-7606	1568676	LM-10062S	1E0028012	F8-5410	3M51-18A116-AB	F8-6357
1386188	F8-8112	1591585	G9-500	1E0028012A	F8-5410	3M51-3K036-AC	AK-735196
1386664	AK-735195	1594853	F8-7650	1E00-34-153A	G9-662	3M51-3K036-AC	F8-7838
1386664	AK-735198	1595905	G9-500	1E00-34-156	F8-6034	3M513K099AC	F8-6268
1386664	AK-735200	1619061	LM-10044S	1E01-34-153A	G9-663	3M513K099AC	F8-7156
1388271	F8-7712	1619120	F8-5075	1J0412249	F8-3039	3M513K099AD	F8-6268
1404976	F8-6641	1619120	G9-522	1S4Q6B319AE	F8-6399	3M513K099AD	F8-7156



FORD		FORD		FORD		FORD	
3M51-3K100-BF	AK-735196	4706416	F8-6316	6135054	F8-6929	6829045	F8-6722
3M513K155BE	F8-6210	4C1Q6B319C1A	F8-7650	6135185	G9-500	6829046	F8-7940
3M513K155BE	F8-7156	4C1Q6B319C1B	F8-7650	6139310	F8-5561	6838725	F8-5503
3M513K155CC	F8-6210	4C1Q6B319DA	F8-7650	6140043	F8-6929	6845225	F8-6833
3M513K155CC	F8-7156	4C1Q6B319DB	F8-7650	6141919	F8-5204	6870549	G9-634
3M513K155DB	F8-6210	4C1Q6B319DC	F8-7650	6144628	G9-501	6908393	F8-6954
3M513K155DB	F8-7156	4M513A23AC	F8-8078	6144628	G9-501S	6911968	F8-7031
3M513K155DC	F8-6210	4M51-3A23-AC	F8-8078	6150276	F8-3020	6941524	F8-7031
3M513K155DC	F8-7156	4M513A424AC	F8-8078	6150276	F8-5880	6961946	F8-7031
3M513K155FA	F8-6210	4M51-3A424-AC	F8-8078	6150277	F8-5507	6995241	F8-7031
3M513K155FA	F8-7156	4M516P093FA	F8-6207	6150277	F8-5880	6C1118183AB	F8-7456
3M513K155FB	F8-6210	4S415599AA	F8-6355	6150277S1	F8-5880	6C1118183AC	F8-7456
3M513K155FB	F8-7156	5021661	G9-500	6150977	F8-6048	6C113025BC	F8-7712
3M515E211ND	F8-6268	5021729	G9-501	6156467	LM-10019S	6C11-3K099-AB	F8-7609
3M51-5K896-AC	F8-6638	5021729	G9-501S	6160070	LM-10019S	6C1Q 6B319CC	F8-6571
3M516F012BF	F8-8197	5062530	F8-6754	6160228	F8-6929	6C1Q6B319AD	F8-8112
3M516F012BG	F8-8197	5208219	F8-6754	6161627	F8-6930	6C1Q-6B319-EA	F8-7651
3M516F012BH	F8-8197	5C1118183AA	F8-6316	6161628	F8-5559	6G91 5A968 FCJ	F8-7878
3M517M121GB	F8-6208	5M5Q-10344-AA	F5-1057	6176933	AK-735149	6G91 5A968 FNJ	F8-7878
3M51GP093	F8-6209	5M5Q-10344-AB	F5-1057	6178901	F8-6953	6G91 5A969 FCJ	F8-7877
3M5J3A262BP	F8-8078	6 160 229	F8-5561	6185027	F8-6952	6G91 5A969 FNJ	F8-7878
3M5J-3A262-BP	F8-8078	6 203 710	F8-6506	6185809	F8-6034	6G91 5K896	F8-7877
3M5Q 6B319 AA	F8-7861	6042740	F8-5075	6186726	F8-6953	6G91 5K896	F8-7878
3M5T-10300-VC	F5-1059	6042740	G9-522	6192705	G9-524	6G91 5K896 AA	F8-7877
3M5T-10300-VD	F5-1059	6049904	F8-5562	6203710	F8-6506	6G91 5K896 BA	F8-7878
3N61-18A116-AA	F8-6357	6069772	G9-500	6203826	F8-6356	6G913K036NAA	AK-735192
3N615K570AA	F8-7583	6087890	F8-5075	6203826S	F8-6260	6G91-3K099-NAB	F8-7607
3S51-3025-AC	AK-735405	6087890	G9-522	6495311	F8-5522	6G91-3K099-NAB	F8-7608
4041449	F8-7582	6087890S1	F8-5075	6495311	F8-6307	6G91-3K099-NBA	F8-7607
4041450	F8-6163	6087914	G9-500	6517356	F8-5135	6G91-3K099-NBA	F8-7608
4041955	F8-6164	6090611	F8-5075	6532212	AK-735404	6G91-3K155-AAD	F8-7606
4041955	F8-6316	6090611	G9-522	6543416	F8-6034	6G91-3K155-AAD	F8-7608
4042024	F8-6162	6094239	F8-5204	6608818	F8-5252	6M2110344AA	F5-1004
4053300	F8-6164	6095487	F8-5880	6675788	F8-5505	6M2110344BA	F5-1004
4053300	F8-6316	6107025	G9-500	6675788	F8-6313	7038493	F8-7031
4060617	F8-8224	6112404	F8-3018	6708739	AK-735033	7055289	F8-6954
4070497	F8-6164	6112404	F8-6307	6708739	F8-8120	7068451	F8-7031
4070497	F8-6316	6119999	F8-5507	6708751	F8-6554	7102392	F8-6034
4094280	F8-6164	6119999	F8-5880	6714195	F8-6137	7128520	F8-6970
4094280	F8-6316	6120493	F8-5204	6735956	F8-6262	7144202	F8-7915
4094373	F8-6164	6122229	F8-5204	6735956	F8-6308	7144204	F8-6639
4094373	F8-6316	6122507	G9-501	6735956	F8-6316	7200957	F8-5407
4104708	F8-8224	6122507	G9-501S	6745350	F8-7935	7201688	F8-3039
4131788	F8-6163	6127744	F8-5038	6763456	F8-5505	7201717	G9-665
4360393	F8-6164	6128736	LM-10027S	6763456	F8-6313	7201848	F8-1034
4372132	F8-6162	6129161	G9-501	6772173	LM-10034S	7201848S1	F8-1034S
4377687	F8-5329	6129161	G9-501S	6790115	G9-633	7229329	F8-6930
4386426	F8-5408	6130060	F8-6307	6799585	F8-5504	7234729	F8-6356
4386426	F8-7102	6130061	F8-5507	6799585	F8-6308	7234729S	F8-6260
4453803	AK-735077	6130061	F8-5880	6803993	F8-7031	7234730	F8-5406
4540787	F8-6162	6130307	F8-3020	6803994	F8-7031	7239265	F8-8224
4706416	F8-6164	6130307	F8-5880	6807407	F8-5503	7240354	F8-6970



FORD		FORD		FORD		FORD	
7240357	F8-6971	85BB3K132AA	F8-5880	93BB-3063-AA	G9-633	96FB3063AB	G9-662
7242755	F8-6954	85GB3063AB	G9-524	93BB3A262BA	G9-634	96FB3A262AD	G9-663
7270635	F8-5530	85GB3063AC	G9-524	93BB3K099AB	F8-6262	96FB-3C156-AC	F8-6559
7280607	F8-6970	85GB5493AB	G9-501	93BB3K099AB	F8-6308	96FB-3C156-AE	F8-6559
7280608	F8-6971	85GB5493AB	G9-501S	93BB3K155AC	F8-5504	96FB3K099AB	F8-5413
7304921	F8-7031	86AB5484AA	F8-5080	93BB3K155AC	F8-6308	96FB3K099AB	F8-6312
7304922	F8-7031	86AB5484BA	F8-5070	93BB-3W015-AA	F8-6554	96FB3K099AG	F8-6312
7320351	F8-6079	86VB-3K661-A1C	LM-10019S	93BB4A037EA	F8-6639	96FB3K155AG	F8-5412
7331751	F8-3019	86VB-3K661-AB	LM-10019S	93BB-5484-AB	F8-6137	96FB-3W015-BB	F8-6556
7331751	F8-5447S	86VB5484AB	F8-6048	93BB-5K653-AB	F8-6722	96FB5484CA	F8-5328
7350847	F8-5447	880X5K897AA	G9-500	94AB5484AA	F8-6034	96FB-5K653-CA	F8-6074
7350847	F8-5447S	88GB5493AA	G9-501	94AB5484AB	F8-6034	96FB6038BJ	F8-6926
7350847S	F8-5447S	88GB5493AA	G9-501S	94FB-3K661-AC	LM-10007S	96FB6038BK	F8-6926
7350848	F8-6557	88GX5493AA	G9-501	94FB6038AA	F8-6930	97 KB 5484AA	F8-5328
7354179	F8-6970	88GX5493AA	G9-501S	95AB-3K036-AD	AK-735404	97AG5K653AA	F8-5971
7354180	F8-6971	89AB6038BB	F8-6953	95AB-3K036-AD	AK-735405	97BB6P082AB	F8-7031
7371059	F8-5329	89FB3063AD	G9-585	95AB3K099AA	F8-3019	97BB6P082CA	F8-7031
7372131	F8-6162	89FB5474BA	F8-6034	95AB3K099AA	F8-5447S	97BG3K099AA	F8-6308
7379687	AK-735404	89FB5484BA	F8-6034	95AB3K099AB	F8-3019	97BG-3K099-AA	F8-6262
7379687	AK-735405	89FB5599AC	F8-6356	95AB3K099AB	F8-5447S	97BG-5A318-AB	F8-6553
7396830	G9-664	89FB-5599-AC	F8-6356	95AB3K155AD	F8-5447	97FB3K155AA	F8-5409
7398680	F8-5051	89FB5599ACS	F8-6260	95AB3K155AD	F8-5447S	97KB6038AD	F8-6958
7398680	LM-10023S	89FB-5599-ACS	F8-6260	95AB3K155ADS	F8-5447S	97KB-6B032-AE	F8-6756
7403748	F8-5530	89FB6038AA	F8-6930	95AB5599AA	F8-6356	97KB-6B032-AF	F8-6756
7G913K100DAA	AK-735192	89FB6038CB	F8-6952	95AB-5599-AA	F8-6356	97KB-6B032-AG	F8-6756
7G9J3A262AB	F8-8074	8N61-18A116-AB	F8-6357	95AB5599AAS	F8-6260	98AB6038CH	F8-6475
7G9J-3A262-AB	F8-8074	8V5118A116AA	F8-7434	95AB-5599-AAS	F8-6260	98AB6038DG	F8-8165
7G9J3A262BB	F8-8075	8V51-3025-AB	AK-735435	95AB5789AA	F8-5406	98AB6P082AG	F8-7030
7G9J-3A262-BB	F8-8075	8V513K099AC	F8-7433	95AB-5A318-AD	F8-6557	98AB6P082AH	F8-7030
7G9N3A052BB	F8-8075	8V513K099AD	F8-7433	95AB-5K653-CA	F8-5329	98AB-6P082-MA	F8-6754
7G9N-3A052-BB	F8-8075	8V513K099AE	F8-7433	95BB6P082DA	F8-7031	98AB-6P082-MB	F8-6754
7G9N3A053BB	F8-8074	8V513K155AF	F8-7432	95BG3A262AA	F8-5136	98AG3025AD	F8-6060
7G9N-3A053-BB	F8-8074	8V513K155BA	F8-7432	95BG3A262BA	F8-5136	98AG3035AD	F8-6060
7M0407181A	G9-664	8V513K155CA	F8-7432	95FB-5C485-AA	F8-6079	98AG3063AE	F8-6015
7M0412303B	F8-5995	8V51-5349-AA	AK-735435	95VB-4826-AA	F8-8224	98AG3K036AB	F8-7686
7M0505221C	F8-5530	8V51-5349-AB	F8-7489	95VB6038BF	F8-6970	98AG-3K099-AB	F8-6318
7M516F012YB	F8-8196	8V61-18159-AB	AK-735451	95VB6B032BD	F8-6971	98AG-3K099-AB	F8-6511
81AB3063AA	F8-5075	8V61-18159-AB	F8-7480	95VW10344FA	F5-1007	98AG3K155AB	F8-6066
81AB3063BB	G9-522	90BB-3025-AA	AK-735404	95VW3025CB	F8-5995	98AG-3K155-AB	F8-6318
81AB5K897AB	G9-500	91AB3A262AA	G9-586	95VW-36661-AC	LM-10023S	98AG3K155AE	F8-6066
81AB5K897BA	G9-500	91AB3K155AA	F8-5522	95VW3A262BA	G9-664	98AG3K155AE	F8-6318
81AB5K897BB	G9-500	91AB3K155AA	F8-6307	95VW3A638CA	G9-664	98AG3K155AF	F8-6066
83BB3K099AB	F8-3018	91AB3K155AB	F8-5522	95VW3K031AA	F8-1034	98AG3K155AF	F8-6318
83BB3K099AB	F8-6307	91AB3K155AB	F8-6307	95VW3K661AC	F8-5051	98AG4A037BA	F8-6732
83BB3K132AB	F8-5507	91AB6L028CB	F8-6833	95VW5484AB	F8-5407	98AG5484DA	F8-5330
83BB-3K661-BD	LM-10044S	92VB3069AA	F8-5135	95VW5K818BB	F8-5530	98AG5599AC	F8-6355
83BB5K817BA	F8-5204	92VB3432AA	F8-5252	95VW5K818BC	F8-5530	98AG-5A318-AD	F8-6555
84FB6038AE	F8-6929	92VB3K155AD	F8-5505	96FB18198AC	F8-5410	98AG-5A318-AE	F8-6555
84FB6038AF	F8-6929	92VB3K155AD	F8-6313	96FB18198AD	F8-5410	98AG5K570AH	F8-6061
85BB3K099AA	F8-3020	92VB6038BC	F8-6954	96FB18198AF	F8-5410	98AG-5K896-AB	F8-6638
85BB3K099AA	F8-5880	93BB18198	F8-5503	96FB18198AG	F8-5410	98BB6P082AA	F8-7031
85BB3K132AA	F8-5507	93BB18198BC	F8-5503	96FB3063AA	G9-662	98BB6P082CA	F8-7031



FORD	
98BG3K099AA	F8-6308
98BG-3K099-AA	F8-6262
98BG3K099AB	F8-6308
98BG-3K099-AB	F8-6262
98BG3K099AC	F8-6308
98BG3K099AC	F8-6316
98BG-3K099-AC	F8-6262
98FB3063AA	G9-662
98FB3A262AA	G9-663
99VB-4826-AB	F8-8224
9S5118198BA	F8-7435
9S5118198BC	F8-7435
9S5118A047AC	F8-7594
9T16-6P082-BA	F8-6754
9T16-6P082-BB	F8-6754
AB5K653AC	F8-5971
AV61-18A116-A	F8-6357
AV61-18A116-AC	F8-6357
AV61-18A116-AD	F8-6357
AV61-18A116-AE	F8-6357
AV61-3A423-PA	F8-7855
AV61-3A424-PA	F8-7854
AV61-3A424-PA	F8-7855
AY11-3K100-AB	F8-7896
BK21-18183-AA	F8-7456
BK21-3K099-AB	F8-7609
BK3Q-6B319-CA	F8-7651
BK3Q-6B319-CB	F8-7651
BV61-3K100-AA	F8-7483
BV61-5K619-AA	AK-735451
BV61-5K619-AA	F8-7479
F33C-3K661-AA	LM-10034S
F6RC-3K661-AA	LM-10034S
GA2A-34-380	F8-7438
K80118W11	F5-1040
TKA 181351	F8-7877
TKA 181352	F8-7878
V97FB3K155AA	F8-5409
VP2M5U10A352AA	F5-1094
VP6S4U10A352AA	F5-1094
XS4Q6B319FC	F8-6387
XS4Q6B319FD	F8-6387
XS615484BA	F8-5328
XW4U10A352AA	F5-1040
YC1518183AG	F8-6164
YC1518183AG	F8-6316
YC153025AC	F8-7582
YC153069AF	F8-6163
YC153069AG	F8-6163
YC153A262AD	F8-6162
YC153A262AE	F8-6162
YC153A262AF	F8-6162

FORD	
YC153K099AA	F8-6316
YC1W-4826-BC	F8-8224
YM213K661AA	F8-5051
YM21-3K661-AA	LM-10023S
YM21-6A026-JB	F8-7032
YM2E10N356AA	F5-1040
YP2C1U-10A352-A	F5-1023
YS413K155AB	F8-6066
YS413K155AB	F8-6318
YS4Z-5493-BA	F8-6732
YS61-5A318-AB	F8-6558
YS61-5A3318-AA	F8-6558
YS81-5484-AA	F8-6137

HONDA	
31141-RBD-E02	F5-1136
31141-RL0-G01	F5-1143
50841-SR3-984	F8-8160
50842-SR3-030	F8-8159
50842-SR3-984	F8-8159
51306-S04-N01	F8-8029
51306-S7B-014	F8-8031
51312SR3000	F8-5294
51391-S04-005	F8-8027
51392-S5A-004	F8-8028
51392-SR3-024	F8-6073
51393-S1A-E01	F8-5278
51393-SK3-000	F8-5123
51393-SL5-013	F8-5278
51393-SV1-A01	F8-5278
51393-SV1-E01	F8-5278
51395-SR3-N02	F8-8005
51631SB0004	F8-5949
51631-SB0-004S1	F8-5949
51686SMGE01	AK-735205
51687S2H951	AK-735210
51688SDAA01	AK-735206
51722S2H014	AK-735209
51722S2H951	AK-735210
51722S5A701	AK-735203
51722-S5A-701	AK-735203
51722S7A014	AK-735211
51722SMGE04	AK-735205
51726-S5A-004	F8-7462
51726-SAA-003	F8-6266
51810SM4004	F8-5279
51920-S5A-024	F8-7462
51920-S6M-J02	F8-7462
52306-S9A-005	F8-8030
52365-SH3-000	F8-5982
52370-SH3-000	F8-5988
52385-SR3-000	F8-5988
52385-ST3-G01	F8-5988

HONDA	
52622-SH3-010	F8-5981
52687S5A014	AK-735204
52687-S5A-014	AK-735204
52687S70004	AK-735208
52688S0A004	AK-735207
52722S3N901	AK-735208
52722S5A004	AK-735204
52722-S5A-004	AK-735204
52722S9A014	AK-735212
52722SDAA01	AK-735207
53534-SL4-J01	LM-10046S
53534-SR3-N52	LM-10046S
53534-SR3-N52	LM-10086S
53534-SV4-N01	LM-10046S
RGX100980	F8-5988

HYUNDAI	
2312427000	F8-7871
2312427100	F8-7871
2312427300	F8-7871
2312427400	F8-7871
23124-2A001	F8-7866
231244X010	F8-7865
231244X011	F8-7865
231244X100	F8-7865
373213C150	F5-1119
37321-4A000	F5-1054
37321-4X300	F5-1060
37321-4X301	F5-1060
37322-27010	F5-1055
37322-27012	F5-1055
37322-27500	F5-1124
37322-27501	F5-1124
37322-2F000	F5-1138
37322-2G500	F5-1139
37322-4A001	F5-1054
37322-4A002	F5-1054
37322-4A300	F5-1137
37322-4A310	F5-1137
54551-07001	F8-7067
54551-1E000	F8-7067
54551-25000	F8-7073
54551-26000	F8-7820
54551-2B000	F8-7076
54551-2E000	F8-7821
54552-38000	F8-7818
54555-25000	F8-7817
54555-26000	F8-7819
54584-17000	F8-7074
54584-1G000	F8-7822
54584-2B000	F8-7824
54584-2E000	F8-6576
54584-2H000	F8-7070

HYUNDAI	
54584-38100	F8-7998
5461002010	F8-6366
54610-22000	F8-7463
54610-25000	F8-7463
5461028000	F8-6372
54610-29000	F8-7370
54610-2D000	F8-7370
5461034010	F8-6374
54610-34010	F8-6374
5461202000	F8-6366
54612-1G010	F8-3012
54612-2C000	F8-3012
54612-4D000	F8-6270
5462502000	AK-735327
546251C000	AK-735331
546251C000	AK-735332
546251E100	AK-735213
546252D000	AK-735335
546252E000	AK-735215
5462602000	AK-735327
546261C000	AK-735331
546261C500	AK-735332
5462626000	AK-735217
5462626000	AK-735219
5462627000	AK-735333
5462629100	AK-735213
5462629100	AK-735335
5462629100	AK-735336
546262E000	AK-735215
546262E000	AK-735216
54626-2E000	F8-7441
546283B500	AK-735217
54812-07000	F8-7060
54812-1C000	F8-8018
54812-1G100	F8-7829
54813-17100	F8-7064
54813-1H100	F8-7061
54813-25000	F8-7826
54813-26100	F8-8017
54813-2D102	F8-7828
54813-2H000	F8-7061
54813-3K100	F8-7066
55215-2D000	F8-7072
5532529100	AK-735333
553252D000	AK-735334
553252D000	AK-735336
553252E000	AK-735216
553252E000	AK-735219
55326-07100	F8-7443
553261C000	AK-735330
553261E000	AK-735214
5532627000	AK-735334



HYUNDAI		KIA		KIA		LANCIA	
553262B000	AK-735220	37322-27-012	F5-1055	553701C000	AK-735367	46544151	F8-7436
5534002000	AK-735328	37322-2F000	F5-1138	55513-2G100	F8-7063	46544615	F8-7087
5534002100	AK-735329	37322-2G500	F5-1139	55513-3E000	F8-8024	46819147	F8-7086
55348-34910	F8-7442	37322-4A-000	F5-1054	57740-38000	LM-10030S	46844208	F8-8086
553701C000	AK-735214	37322-4A-001	F5-1054	KGA2A280A5A	AK-735372	5033.39	F8-5936
5537026000	AK-735218	37322-4A-300	F5-1137	KGJ2134015A	AK-735371	503529	F8-3014
5537526000	AK-735218	37322-4A-310	F5-1137	KGJ2134015A	AK-735373	50521707	F8-7421
55513-17000	F8-7065	37322-4X-000	F5-1060	<b>LANCIA</b>			
55513-1H000	F8-8019	54480-3E002	F8-8021	04400895	F8-3017	50703231-PART	F8-6442
55513-22500	F8-7827	54551-07001	F8-7067	0515P2	F8-5636	50703232-PART	F8-6442
555132B200	F8-8123	54551-1E000	F8-7067	07601502	F8-3015	5094.69	F8-5092
55513-2B200	F8-8123	54551-2E000	F8-7821	07602150	F8-5956	51839218-PART	F8-6442
55513-2G100	F8-7063	54551-4D000	F8-8026	07610157	F8-5641	51839219-PART	F8-6442
55513-3K100	F8-8020	54552-38000	F8-7818	07760424	F8-5094	55184474	F8-7087
57740-38000	LM-10030S	54580-3E100	F8-8022	07775940	F8-5858	55187707	F8-7087
<b>JAGUAR</b>		54584-1G000	F8-7822	1303672080	F8-3014	55196301	F8-6393
C2C12560	AK-735357	54584-2B000	F8-7824	1303672080	F8-6304	55200498	F8-7086
C2C12560	AK-735358	54584-2E000	F8-6576	1303672080	F8-7164	5927292	G9-533
C2S14666	AK-735354	54584-2H000	F8-7070	1305782080	F8-5092	60507954	F8-5603
C2S2407	AK-735354	54584-4D000	F8-8025	1307021080	F8-5936	60674507	AK-735380
C2S30429	AK-735356	546023E100	AK-735374	1311716080	AK-735381	60679760	AK-735380
C2S9225	AK-735355	54602-3E100	F8-7446	1311930080	F8-5622	60805971	F8-6914
XR819697	F8-6728	54612-1G010	F8-3012	1311930080	F8-6304	60811372	F8-5514
<b>JEEP</b>		54612-2C000	F8-3012	1311931080	F8-5621	60811373	F8-5513
05175811AA	F5-1126	5462507000	AK-735362	1311931080	F8-7164	60813084	F8-6632
52087635	AK-735320	546251E000	AK-735366	1312317080	F8-6439	71747796	F8-7087
52087636AC	AK-735320	546251H000	AK-735368	1316735080S	F8-6155	7543418	F8-6893
52088705AE	AK-735319	546252E000	AK-735215	1316735080S1	F8-6153	7544643	F8-6911
53013554AD	F5-1033	5462607100	AK-735362	1316736080S	F8-6154	7550361	F8-6955
53013554AE	F5-1033	546261G000	AK-735366	1329669080	F8-3014	7569283	F8-5618
53013554AF	F5-1033	546261H000	AK-735368	1329669080	F8-6304	7601064	G9-530
<b>KIA</b>		5462629100	AK-735364	1329669080	F8-7164	7601065	G9-532
0K01134015A	AK-735375	5462629100	AK-735365	1329669080	F8-6304	7601068	G9-531
0K01134111	AK-735375	546262E000	AK-735215	1400257380	AK-735381	7601500	F8-5514
0K01828111	AK-735376	546262E000	AK-735216	1479759080	F8-5871	7601502	F8-3015
0K201-34390B	F8-7438	54626-2E000	F8-7441	303672080	F8-3014	7601504	F8-5513
0K2FA28015	AK-735370	54626-4D000	F8-7444	3520.G9S	F8-6155	7610157	F8-5641
0K2FA28111	AK-735370	546613E000	AK-735374	3520.G9S1	F8-6153	7613889	F8-6893
0K2FA34015	AK-735369	54812-07000	F8-7060	3521.C9S	F8-6154	7644686	F8-6914
0K2FA34111	AK-735369	54812-1G100	F8-7829	4288726	G9-506	7667850	F8-6887
0K55234111	AK-735373	54813-1H100	F8-7061	4400895	F8-3017	7673581	G9-533
0K9A034111A	AK-735371	54813-2H000	F8-7061	46404169	F8-5938	7676967	G9-533
0K9A228111A	AK-735372	54813-3E000	F8-8023	46413115	F8-7863	7683363	F8-5514
2312427300	F8-7871	54813-3K100	F8-7066	46414183	F8-5514	7683364	F8-5513
23124-2A001	F8-7866	553252D000	AK-735365	46414184	F8-5514	7720288	F8-6956
231244X010	F8-7865	553252E000	AK-735216	46427969	F8-7087	77362558	F5-1046
231244X011	F8-7865	55326071	AK-735363	46439876	F8-7012	77362721	F5-1045
231244X100	F8-7865	553261G000	AK-735367	46445246	F8-5600	77363468	F5-1048
37321-4X-210	F5-1060	55326-4D000	F8-7445	46469709	F8-5600	77363948	F5-1098
37321-4X-300	F5-1060	55348-34910	F8-7442	46476755	F8-5864	77364723	F5-1041
37321-4X-301	F5-1060	55348-4D000	F8-7445	46516096	F8-7648	77364725	F5-1098
37322-27-010	F5-1055	553701C000	AK-735363	46528871	F8-8086	7737417	F8-7013
						7765188	F8-5618





## LANCIA

7773844	F8-7012
7775343	G9-612
7775343L	G9-612
7775344	G9-584
7775344R	G9-584
7775940	F8-5858
7776485	F8-5600
7778028	F8-7648
7778563	F8-6936
7778950	F8-6264
7784313	F8-5415
7792020	F8-6632
82335609	F8-3021
82388242	F8-5640
82398815	F8-5591
82398818	F8-5592
82403819	F8-5599
82406929	F8-5592
82429601	F8-5599
82430666	F8-5603
82483400	G9-635
9404066418	LM-10022S
9405038689	F8-5622
9405038689	F8-6304
9606121080	F8-5026
9613305380	F8-6236
9631575180	F8-8167
9635939980	F8-8149
9641548980	F8-5636
9641884980	F8-8167
9643354180	F8-7861
9947921	LM-10038S
9948513	F5-1123
9949129	F5-1123
9949627	F5-1020
9949627	F5-1039
9951162	F5-1005
9951269	F5-1123
9951287	LM-10038S

## LAND ROVER

ANR6124	AK-735383
EAP7162L	AK-735382
KKB000270	F8-6972
KKB000280	F8-6973
LR015336	F8-8096
LR015339	F8-8097
LR015344	F8-8098
LR018346	F8-8095
RGD500083 PART	F8-6421
RGX500070	F8-8100
RNE10001L	AK-735382
RNE100143	AK-735384

## LAND ROVER

RNH100252	AK-735384
RPC000030	AK-735385
RPC000040	AK-735383
RPG000020	AK-735385
RVU000021	F8-8099

## MAZDA

1003914	F8-5410
1010037	G9-662
1014654	G9-663
1023587	F8-5410
1055191	G9-662
1063372	G9-663
1E00-28-012	F8-5410
1E00-28-012A	F8-5410
1E00-28-460B	F8-5329
1E00-28-460C	F8-5329
1E0034153A	G9-662
1E00-34-156	F8-6034
1E0034380	F8-5412
1E0034380	F8-6312
1E003438X	F8-6312
1E0034390	F8-5412
1E0034390	F8-6312
1E01-34-153A	G9-663
7102392	F8-6034
96FB18198AC	F8-5410
96FB18198AD	F8-5410
96FB18198AF	F8-5410
96FB18198AG	F8-5410
B01C280A5A	AK-735394
B01C34111	AK-735391
B25D28111	AK-735394
B25D34460	F8-6642
B45528111A	AK-735396
B45534111B	AK-735085
B45534111B	AK-735395
BC1D34470	F8-5284
BP4K340A5B	AK-735388
BP4K340A5B	F8-7838
BP4K34111B	AK-735388
BP4K34111C	AK-735388
BP4K-34-380B	F8-6210
BP4K-34-380B	F8-7156
BP4K-34-380C	F8-6210
BP4K-34-380C	F8-7156
BP4K-34-380D	F8-6210
BP4K-34-380D	F8-7156
BP4K3438XA	F8-6268
BP4K-34-38XA	F8-7156
BP4K3438XB	F8-6268
BP4K39040D	F8-8140
BP4K39040E	F8-8140

## MAZDA

BP4L-34-380	F8-6210
BP4L-34-380	F8-7156
BP4L-34-380B	F8-6210
BP4L-34-380B	F8-7156
BP4L-34-380C	F8-6210
BP4L-34-380C	F8-7156
BP4L-34-380D	F8-6210
BP4L-34-380D	F8-7156
C100340A5	AK-735393
C10034111A	AK-735393
C2Y6-28-460	F8-6638
D00134111	AK-735386
D00428111	AK-735387
D20128015	AK-735387
D350-34-28XB	F8-6317
D350-34-28XC	F8-6317
D6513438XA	F8-7433
DD32-34-300-PAR	F8-6159
DD32-34-300-PAR	F8-6160
DD32-34-350-PAR	F8-6159
DD32-34-350-PAR	F8-6160
DD32-34-380	F8-7431
DD32-34-380A	F8-7431
DD3239060	F8-8139
DR61-28-70X	F8-7434
G30628111	AK-735392
GA2A280A5	AK-735390
GA2A280A5	AK-735392
GA2A34111	AK-735389
GA2A-34-460	F8-5283
GA2A3446YA	F8-5282
GA2B34470	F8-5282
GA2B34470A	F8-5282
GA2K28111	AK-735390
GA5R-34-380	F8-7438
GD7B34470	F8-5282
GJ2134015	AK-735389
GJ2134015	AK-735391
GJ6A-28-200B	F8-8225
GJ6A-28-200G	F8-8225
GJ6A-28-200J	F8-8225
GJ6A-28-200K	F8-8225
GJ6A34012	AK-735432
GJ6A34015A	AK-735433
GJ6A34111C	AK-735432
GJ6A34111C	AK-735433
GY02-11-W11A	F5-1027
GY02-18-330	F5-1040
GY02-18-330A	F5-1027
GY02-18-330B	F5-1027
GY02-18-W37Z	F5-1027
K801-18-W11	F5-1040

## MAZDA

L3M6-18-W11	F5-1142
L3M6-18-W11A	F5-1142
L3M6-18-W11B	F5-1142
LW18-18-W11	F5-1082
RF5C-18-330	F5-1097
RF5C-18-330A	F5-1097
RF5C-18-W11	F5-1097
U201-18-W10	F5-1047
U201-18-W10	F5-1101

## MERCEDES-BENZ

0003210050	F8-5205
0003210250	F8-5779
0003210350	F8-5205
0004110200	F8-6760
1073300275	F8-5720
1074102181	F8-4001
1074102281	F8-4001
1120350000	F8-5663
1120350400	F8-5663
1120350500	F8-5663
1120350600	F8-5663
1120350800	F8-5663
1120350900	F8-5663
1120351300	F8-5663
1120351400	F8-5663
1153200344	F8-5770
1153301475	F8-5720
1153333014	F8-5688
1153333514	F8-5688
1153523265	F8-4005
1153523265	F8-5730
1153523665	F8-4005
1153523665	F8-5730
1163334014	G9-588
1163336314	G9-514
1164102781	F8-4001
1164102981	F8-4001
1164103081	F8-4001
1165860133	F8-5020
1232414113	F8-8194
1233230585	F8-5137
1233301375	F8-5178
1233500075	F8-5731
1233500175	F8-5739
1233511042	F8-5732
1233520565	F8-4005
1233520565	F8-5730
1234101081	F8-4001
1234600050	F7-9001
1235860333	F8-5178
1235860435	F8-5731
1235860535	F8-5739



MERCEDES-BENZ		MERCEDES-BENZ		MERCEDES-BENZ		MERCEDES-BENZ	
1242400018	F8-6498	1243528465	F8-5678	1403331814	F8-7876	2012401317	F7-2003
1242400217	F7-2003	1243528665	G9-652	1403524465	F8-6811	2012402617	F7-2003
1242400317	F8-5005	1243529065	G9-651	1403524565	F8-8128	2012402717	F8-5005
1242400318	F8-6498	1244100015	F8-5015	1403524665	F8-6812	2012403917	F7-2003
1242400618	F8-6498	1244100115	F8-7130	1403524865	F8-8128	2012404017	F8-5005
1242401617	F7-2003	1244100181	F8-4002	1403524965	F8-6812	2012404117	F8-5449
1242401717	F8-5005	1244100281	F8-4003	1403528065	F8-5679	2012404317	F8-2005
1242401917	F8-2005	1244100615	F8-7130	1403528665	F8-5679	2013200744	F8-5613
1242402617	F8-5004	1244100681	F8-4002	1404600819	F8-7103	2013202444	F8-5613
1243200273	F8-5811	1244100715	F8-7130	1603180	MK-822920	2013231444	F8-5901
1243200473	F8-5811	1244100781	F8-4003	1632400217	F8-8192	2013232044	AK-735019
1243201444	F8-5502	1244600019	F7-9001	1632400218	F8-8185	2013232044	F8-5901
1243202144	F8-5811	1244600119	F7-9001	1632400317	F8-8193	2013234985	F8-5218
1243230744	F8-5918	1244600150	F7-9001	1632400417	F8-8203	2013261081	F8-5670
1243231885	F8-5973	1263230185	F8-5120	166 030 0303	F8-6400	2013261481	F8-5671
1243232885	F8-5216	1263300075	F8-5256	1661550215	F5-1026	2013300075	F8-5011
1243233085	F8-5973	1263333014	F8-5131	1682400618	F8-8154	2013300175	F8-5185
1243233785	F8-5219	1263333814	G9-544	1682401217	F8-8126	2013330043	F8-5185
1243233885	F8-5973	1263335414	F8-5131	1682401218	F8-8154	2013334514	G9-667
1243234385	F8-5216	1263500175	F8-5767	1682401617	F8-8126	2013335114	F8-5010
1243234485	F8-5973	1263520165	F8-4005	1683200073	F8-5834	2013512742	F8-5018
1243234685	F8-5216	1263520165	F8-5730	1683200173	F8-5834	2013512842	F8-5697
1243234985	F8-5214	1264100181	F8-4006	1683200373	F8-5834	2013513642	F8-5420
1243235085	F8-5209	1264100215	F8-6235	1683230085	F8-5834	2013520027	F8-5297
1243235485	F8-5236	1264100515	F8-7130	1683230192	AK-735221	2013528765	G9-503
1243235685	F8-5217	1264600819	F7-9001	1683330014	F8-5326	2013528865	G9-503
1243300275	F8-5009	1265860033	F8-5256	1683330214	F8-5325	2014100581	F8-7054
1243300575	F8-5009	1265860035	F8-5767	1683330614	F8-5325	2014100615	F8-5015
1243300675	F8-5195	1292400917	F8-5004	1683330714	F8-5326	2014101815	F8-7130
1243300975	F8-6473	1292401517	F8-5004	1683520080	F8-6100	2014102115	F8-5016
1243333814	G9-544	1293230185	F8-5222	1683570148	F8-6100	2014600050	F8-5582
1243334214	F8-6804	1293230192	AK-735019	1683570248	F8-6100	202 330 01 75	F8-6474
1243334314	F8-6805	1293230744	F8-5914	1683570472	F8-6100	2022400218	F8-8178
1243500341	F8-6230	1293510742	F8-5874	1683570671	F8-6100	2022400418	F8-6924
1243500441-PART	F8-5018	1293511542	F8-5821	1683570771	F8-6100	2022400518	F8-6924
1243506408	F8-6230	1293511842	F8-5874	1689810318	F8-6100	2022401218	F8-8178
1243506708	F8-5697	1293512142	F8-5873	1689810518	F8-6100	2022401418	F8-6924
1243508608	F8-5820	1293520065	F8-5678	1692400518	F8-6644	2022401617	F8-5461
1243508608-PART	F8-5018	1294100015	F8-6239	1692400618	F8-6645	2022401717	F8-5460
1243510242	F8-5773	1402401218	F8-7747	1692400817	F8-6643	2022401917	F8-5461
1243511342	F8-5744	1402401718	F8-7747	1692401218	F8-6646	2022402017	F8-5461
1243511942	F8-5018	1403230985	F8-5149	1692401517	F8-6643	2022402317	F8-5458
1243512242	F8-5744	1403231085	F8-5113	1693200073	F8-6518	2022402617	F8-5461
1243516408	F8-6230	1403231485	F8-5229	1693230192	AK-735222	2022402917	F8-5458
1243520267	F8-5744	1403231985	F8-5231	1703300075	F8-5197	2022404417	F8-5458
1243523565	F8-5327	1403306007	F8-5176	1704100015	F8-6239	2023230285	F8-5227
1243523665	F8-5678	1403306307	F8-5176	1713230044	AK-735225	2023300075	F8-5023
1243523765	F8-5678	1403308207	F8-5176	1713510142	F8-6148	2023336214	F8-6814
1243524165	F8-5733	1403311444	F8-5974	1714630096	LM-10082S	2023336414	F8-5477
1243524365	G9-503	1403311544	F8-5975	201 333 52 14	F8-6468	2023337714	F8-6813
1243527065	F8-5678	1403312244	F8-5978	2012400318	F7-2069	2023338414	F8-5477
1243527765	F8-5733	1403331714	F8-8127	2012400618	F7-2069	2023338714	F8-5307



MERCEDES-BENZ		MERCEDES-BENZ		MERCEDES-BENZ		MERCEDES-BENZ	
2023503408	F8-5697	2049810025	F8-7478	2123230020	F8-7628	2303521865	F8-8129
2023510842	F8-5698	2049810025	F8-7631	2123230392	F8-7899	2661550115	F5-1081
2023520065	F8-5678	208 333 01 14S	F8-6467	2123260464	F8-7626	2711550016	F5-1056
2023520165	F8-5678	210 325 03 84	F8-6466	2123260564	F8-7626	2711550115	F5-1056
2024100747	F8-5017	2102400118	F8-8178	2123330014	F8-7739	2D0511171	F8-5019
2024101215	F8-5016	2102400217	F8-5461	2123330314	F8-8116	2D0511171B	F8-5788
2024600319	F8-5181	2102400318	F8-8178	2123330514	F8-7740	2D0511181	F8-5979
203 240 12 17	F8-6647	2102400418	F8-5308	2183260064	F8-7626	2D0511413A	F8-5846
203 320 02 73	F8-6539	2102400518	F8-5308	2183260464	F8-7626	3093200073	F8-8101
2032400317	F8-5461	2102400617	F8-5461	2202400118	F8-7747	3143260153	F8-8101
2032400417	F8-5461	2102400717	F8-5459	2202400418	F8-7747	3210050	F8-5205
2032400517	F8-5461	2102400817	F8-5458	2203308607	F8-6652	3210150	F8-5205
2032401917	F8-6950	2102401317	F8-5007	2203308707	F8-6652	3210250	F8-5779
2032402017	F8-6951	2103231485	F8-5210	2203309107	F8-6652	3210350	F8-5205
2032402117	F8-8153	2103300175	F8-5198	2203331714	F8-6652	3210450	F8-5779
2032411113	F8-6647	2103300475	F8-5198	2203333014	F8-6652	4503220015	F8-6552
2033200744	AK-735081	2103335514	F8-5309	2203333114	F8-6652	4513200029	F8-6551
2033200844	AK-735226	2103505808	F8-5917	2203520027	F8-5297	4513200229	F8-6551
2033230292	AK-735223	2103505908	F8-5827	2203520227	F8-5297	6013210350	F8-5752
2033230685	F8-5980	2103510542	F8-5826	2203521365	F8-6182	6013240050	F8-5769
2033330514	F8-7932	2103510842	F8-5916	2213300285	M-871000	6013240150	F8-5769
2033331014	F8-7858	2103520665	F8-8128	2213300285	MK-871000	6013260482	F8-5704
2033510742	F8-6148	2104100815	F8-6239	2213330714	F8-7377	6014100410	F8-5014
2034100215	F8-6760	2112400017	F8-6968	2213330814	F8-8087	6014101210	F8-5014
2034100315	F8-6761	2112400317	F8-8175	2213500206	F8-7667	6014101510	F8-5014
2034602300	LM-10082S	2112400517	F8-8153	2213500206	F8-7668	6014101710	F8-5014
2034630296	LM-10082S	2112402017	F8-6969	2213500406	F8-7665	6014105010	F8-5014
204 323 00 44	F8-8079	2112403017	F8-8153	2213500406	F8-7666	6014920082	F8-4027
2043200073	F8-7477	2112403417	F8-8175	2213500606	F8-7665	6015860041	F8-5014
2043200073	F8-7478	2113200026	F8-6059	2213500606	F8-7666	6021500060	F5-1003
2043200373	F8-7626	2113210006	F8-7713	2213500706	F8-7665	6023210050	F8-5751
2043200873	F8-7626	2113230444	F8-7799	2213500706	F8-7666	6023210250	F8-5751
2043200973	F8-7626	2113331014	F8-6112	2213500806	F8-7665	6023210350	F8-5751
2043201073	F8-7626	2113331914	F8-6113	2213500806	F8-7666	6023210450	F8-5751
2043201273	F8-7477	2113332214	F8-6651	2213501006	F8-7667	6023240050	F8-5769
2043201273	F8-7478	2113332514	F8-6112	2213501006	F8-7668	6023240150	F8-5769
2043210106	AK-735224	2113332814	F8-6112	2213501153	F8-7669	6023260282	F8-5750
2043230044	AK-735223	2113332914	F8-6112	2213501153	F8-7670	6023260482	F8-5753
2043230044	F8-8079	2113510642	F8-6119	2213501253	F8-7669	6023260882	F8-5705
2043260098	AK-735224	2113510842	F8-6120	2213501253	F8-7670	6041500060	F5-1003
2043260664	F8-7626	2113511042	F8-6184	2213521165	F8-7667	6041500160	F5-1001
2043260764	F8-7626	2113511142	F8-6119	2213521265	F8-7668	6041500360	F5-1003
2043303111	F8-7671	2113511342	F8-6184	2213521365	F8-7665	6041500460	F5-1099
2043303211	F8-7671	2113511442	F8-6184	2213521465	F8-7666	6041500560	F5-1001
2043306711	F8-7671	2113520865	F8-6161	2213522165	F8-7669	6041500660	F5-1099
2043306811	F8-7671	2114100115	F8-7720S	2213522265	F8-7670	6111500160	F5-1017
2043330414	F8-7671	2114100415	F8-7721S	2303330114	F8-6652	6111500360	F5-1018
2043331014	F8-7858	2122400318	F8-7747	2303330214	F8-6652	6111501650	F5-1018
2043331114	F8-7858	2123210106	F8-7690	2303510242	F8-6181	6111550015	F5-1018
2043520027	F8-5297	2123210306	F8-7689	2303511442	F8-6144	6111550215	F5-1017
2043521065	F8-6648	2123210706	F8-7691	2303521465	F8-8130	6111550315	F5-1019
2043530043	F8-6145	2123210906	F8-7692	2303521565	F8-6145	6111550415	F5-1018



MERCEDES-BENZ	
6111550515	F5-1019
6111550715	F5-1019
6113240050	F8-5684
6113240350	F8-5684
6113240450	F8-5684
6113260081	F8-5825
6261500060	F5-1126
6281500060	F5-1065
6281550015	F5-1042
6291500060	F5-1114
6382411413	F8-6465
6383200029	F8-7629
6383230285	F8-6231
6383230320	F8-5967
6383230320	F8-6380
6383230420	F8-5967
6383230420	F8-6380
6383330014	F8-6136
6383330814	F8-6135
6383330814	F8-6135S
6383520650	F8-6057
6389810120	F8-5962
6389810120	F8-6380
6392410513	F8-6967
6393210206	AK-735445
6393230298	AK-735445
6393230420	F8-7630
6393230520	F8-7630
6393301207	F8-8082
6393301207	F8-8083
6393301307	F8-8082
6393301307	F8-8084
6393301401	F8-8082
6393301401	F8-8083
6393301501	F8-8082
6393301501	F8-8084
6399810025	F8-7629
6399810125	F8-7629
6399810225	F8-7629
6399810325	F8-7629
6401500160	F5-1121
6401500360	F5-1121
6401500560	F5-1121
6401500660	F5-1121
6401500760	F5-1121
6401500960	F5-1121
6421500360	F5-1126
6421500660	F5-1126
6421500760	F5-1111
6421500860	F5-1065
6461500260	F5-1058
6481550015	F5-1058

MERCEDES-BENZ	
6681550215	F5-1121
6681550615	F5-1121
901 323 00 85	F8-6700
901 333 02 14	F8-6529
9012412513	F8-8147
9012421413	F8-8144
9012421513	F8-8144
9013230185	F8-6017
9013230285	F8-5261
9013240050	F8-5979
9013240150	F8-5019
9013240250	F8-5788
9013260081	F8-5846
9014110312	F8-6240
9014110412	F8-6240
9014605500	LM-10056S
9014620096	LM-10033S
90421747	MK-822920
9043230085	F8-5378
9043260881	F8-5453
9043261081	F8-7920
9063230040	F8-8105
9063230040	F8-8106
9063231485	F8-8105
9063231685	F8-8106
9063233585	F8-8105
9063233685	F8-8106
9063330014	F8-7161
9063330114	F8-7162
A1243201444	F8-5502
A-1293230192	AK-735019
A1403331714	F8-8127
A1403524565	F8-8128
A1403524865	F8-8128
A1682401217	F8-8126
A1682401617	F8-8126
A-1693200073	F8-6518
A-2013232044	AK-735019
A-2033230292	AK-735223
A204 323 00 44	F8-8079
A2043200073	F8-7477
A2043200073	F8-7478
A2043200373	F8-7626
A2043200873	F8-7626
A2043200973	F8-7626
A2043201073	F8-7626
A2043201273	F8-7477
A2043201273	F8-7478
A-2043210106	AK-735224
A2043230044	F8-8079
A-2043230044	AK-735223
A-2043260098	AK-735224

MERCEDES-BENZ	
A2043260664	F8-7626
A2043260764	F8-7626
A2049810025	F8-7478
A-2049810025	F8-7631
A2103520665	F8-8128
A2113210006	F8-7713
A2113230444	F8-7799
A2123210106	F8-7690
A2123210306	F8-7689
A2123210706	F8-7691
A2123210906	F8-7692
A-2123230020	F8-7628
A2123260464	F8-7626
A2123260564	F8-7626
A2123330314	F8-8116
A2183260064	F8-7626
A2183260464	F8-7626
A2213300285	M-871000
A2213300285	MK-871000
A2303521465	F8-8130
A2303521865	F8-8129
A4503220015	F8-6552
A4513200029	F8-6551
A4513200229	F8-6551
A-6383200029	F8-7629
A6383330814	F8-6135
A6383330814	F8-6135S
A-6393230420	F8-7630
A-6393230520	F8-7630
A-6399810025	F8-7629
A-6399810125	F8-7629
A-6399810225	F8-7629
A-6399810325	F8-7629
A9063230040	F8-8105
A9063230040	F8-8106
A9063231485	F8-8105
A9063231685	F8-8106
A9063233585	F8-8105
A9063233685	F8-8106

MINI	
12317576515	F5-1113
31126757551	F8-5298
31126757561	F8-6574
31126757562	F8-6575
31126772235	F8-8205
31126772236	F8-8206
31306759454	AK-735230
31306759455	AK-735228
31306764884	F8-6368
31306769741	F8-6368
31306772749	F8-7837
31306777049	F8-7705

MINI	
31306778833	F8-6368
31330146239	AK-735228
31330146239	AK-735230
31330146239	F8-6545
31330146239	F8-7336
31331094749	F8-6545
31331094749	F8-7336
31336759498	F8-6368
33506763137	AK-735231
3350-6789027	F8-7464
3350-6789028	F8-7464
3352-6754123	F8-7464
3352-6754124	F8-7464
33531507254	AK-735229
33531507254	AK-735231
33531518391	AK-735229
33536772740	F8-7710

MITSUBISHI	
A252C55975	F5-1130
A252C559FE	F5-1130
A252C564FE	F5-1150
A6 28X9 2071	F5-1097
A628X91371	F5-1027
M345812	F5-1025
MB303069	AK-735233
MB303070	AK-735023
MB303070	AK-735233
MB303070	AK-735234
MB338594	F8-8035
MB501711	LM-10016S
MB518798	F8-6372
MB518957	AK-735023
MB518957	AK-735234
MB808306	F8-6373
MB809222	F8-6469
MB809223	F8-6469
MB809284	AK-735235
MB809285	AK-735235
MD110165	F8-7860
MD374223	F8-7870
MR102063	F8-6696
MR130982	F8-5249
MR150092	F8-8032
MR150767	F8-8034
MR197462	AK-735236
MR267649	F8-8033
MR316540	AK-735238
MR403441	F8-7129
MR594123	AK-735232
MR594134	AK-735232
MR961189	AK-735237



NISSAN		NISSAN		OPEL		OPEL	
112202F601	F8-6827	54320-40U00S1	F8-5946	0 684 697	F8-6494	0344651	F8-7661
1122093J20	F8-6822	5432050Y12	F8-5945	02875013	F8-5333	0344956	F8-7662
11238-00QAA	F8-6693	54320-50Y12S1	F8-5945	0312503	F8-3027	0350078	F8-5332
11238-00QAB	F8-7736	54320-8H310	F8-7371	0312503	F8-6319	0350112	F8-5143
11246-00QAB	F8-6691	54320-8H311	F8-7371	034415	F8-5501S	0350113	F8-5144
11270-00QAA	F8-8188	54320AX600	F8-7057	034416	F8-5501S	0350116	F8-5331
11320BM500	F8-8176	54320-AX600	F8-6525	0344182	F8-5707	0350123	F8-5332
11320-BM500	F8-8176	54320BM400	F8-7465	0344401	F8-7584	0350127	F8-5228
11323-00QAA	F8-6690	54321AX600	F8-6338	0344402	F8-5710	0350130	F8-5211
11323-00QAB	F8-7733	54325-00QAA	F8-6329	0344403	F8-5707	0350138	F8-5230
11350-BV000	F8-6676	54325-00QAB	F8-7151	0344405	F8-5707	0350147	F8-6091
11356-00Q0A	F8-7737	543250M000	F8-5945	0344409	F8-5964	0350153	F8-5333
11356-00QAA	F8-6692	54325-AX000	F8-6338	0344411	F8-5692	0352300	G9-593
1230300Q0A	F8-7657	54325-AX000	F8-7057	0344417	F8-5878	0352301	G9-590
1230300QBD	F8-7093S1	54325-AX000	F8-7152	0344418	F8-5966	0352302	F8-5108
12303AW300	F8-7093S1	54348-00QAA	F8-6329	0344421	F8-5913	0352327	F8-5112
23150-2W200	F5-1035	54423-00QAA	F8-6674	0344435	F8-7663	0352330	G9-591
23150-2W20A	F5-1035	54450-00QAA	F8-6687	0344446	F8-7663	0352334	G9-591
23150-2W20B	F5-1035	5447601B00	F8-5246	0344468	F8-7611	0352335	G9-592
23151-00Q0A	F5-1036	54500-AX600	F8-6523	0344469	F8-7611	0352338	F8-5107
23151-00Q0B	F5-1025	54500-AX600	F8-6662	0344497	F8-7616	0352341	F8-4098
23151-3VD1A	F5-1130	54500-BC41A	F8-6523	0344504	F8-5952	0352342	F8-4097
23151-6N200	F5-1071	54500-BC42A	F8-6523	0344505	F8-3024	0352343	F8-4097
23151-6N20A	F5-1071	54501-AX600	F8-6523	0344505	F8-6324	0352346	G9-593
23151-6N20B	F5-1071	54501-AX600	F8-6662	0344507	F8-5434	0352347	G9-594
23151EB301	F5-1092	54501-BC41A	F8-6523	0344508	F8-5589	0352348	G9-594
23151-EB301	F5-1150	54501-BC42A	F8-6523	0344509	F8-3059	0352349	G9-591
23151-EB30A	F5-1150	5453501B00	F8-5247	0344511	F8-4100	0352351	G9-593
23151-EL010	F5-1127	54560-AX600	F8-6523	0344511	F8-6324	0352352	G9-594
23151-JA02A	F5-1116	54560-AX600	F8-6662	0344512	F8-4100	0352355	F8-4097
23151-JD20A	F5-1127	54570-00QAA	F8-6673	0344512	F8-6324	0352357	F8-4090
23151-JG71B	F5-1129	54570-AX600	F8-6662	0344513	F8-5501	0352358	F8-5110
265031900	F5-1116	54616-00QAA	F8-5087	0344513	F8-5501S	0352364	F8-4090
4410926SK	F8-6197	55046-00QAA	F8-6684	0344514	F8-5501	0352365	F8-5130
48203-00QAD	LM-10032S	55046-00QAB	F8-6684	0344514	F8-5501S	0352458	F8-5108
48203-00QAE	F8-6478	552400M315	AK-735243	0344515	F8-3026	0352864	F8-6729
48203-9C000	LM-10087S	552404U000	AK-735245	0344516	F8-3026	0353280	F8-6038
48203-9C025	LM-10087S	55240AX600	AK-735241	0344517	F8-5304	0353281	F8-6037
48203-Q9025	LM-10048S	55240JD000	F8-7800	0344517	F8-5304S	0374050	MK-822920
48204-53A00	LM-10046S	55320-50Y10	F8-5948	0344518	F8-3025	0374050S	MK-822920
540502Y001	AK-735442	55320-50Y11	F8-5948	0344518	F8-5304S	0402642	F8-3060
5405031U02	AK-735246	55320-50Y12	F8-5948	0344519	F8-5450	0402645	F8-4102
540505F110	AK-735239	55320BM400	F8-7466	0344519	F8-6319	0402649	F8-5911
54050AX601	AK-735240	55466-00QAA	F8-6661	0344522	F8-5434	0402935	F8-4101
54050JD00A	AK-735436	5621861L10	F8-5947	0344523	F8-5448	0402942	F8-5337
540520M011	AK-735242	56218-61L10S1	F8-5947	0344524	F8-3025	0423302	F8-6098
540524M400	AK-735244	7700802667	AK-735257	0344524	F8-5304S	0423313	F8-4099
54310-00QAA	F8-6329	7701207491SK	F8-6197	0344525	F8-5463	0423315	F8-5722
5431000QAB	F8-6197	A660C-300BX	F5-1062	0344526	F8-7632	0423316	F8-5723
54310-00QABSK	F8-6197	A660C-300BX	F5-1095	0344573	F8-7616	0423318	F8-6098
54320-00QAA	F8-6196	A660C-300EX	F5-1062	0344591	F8-7372	0436426	F8-7612
54320-40U00	F8-5946	A660C-300EX	F5-1095	0344628	F8-7611	0436427	F8-7613



OPEL		OPEL		OPEL		OPEL	
0436933	F8-5912	1204151	F5-1102	1603146	MK-820820	344446	F8-7663
0436940	F8-5611	1204175	F5-1102	1603179	M-820820	344468	F8-7611
0436955	F8-5721	1204184	F5-1135	1603179	MK-820820	344469	F8-7611
0444 200	F8-6660	1204376	F5-1079	1603180	M-822900	344497	F8-7616
0444153	F8-5724	1204393	F5-1100	1603180	MK-822920	344503	F8-7172
0444199	F8-5724	1204412	F5-1050	1603204	M-822900	344503	F8-7330
0444200	F8-6660	1204413	F5-1123	1603204	MK-822920	344504	F8-5952
0444325	F8-5338	1204517	F5-1045	1609095	LM-10030S	344505	F8-3024
0444336	F8-5338	1204879	F7-2054	1609109	LM-10041S	344505	F8-6324
0444347	F8-5970	1204885	F8-5366	22151076	AK-735254	344507	F8-5434
0458009	F8-4106	1204892	F7-2055	22166978	AK-735254	344508	F8-5589
0458014	F8-7053	13115706	F8-6944	22173720	AK-735254	344509	F8-3059
0458364	F8-6766	13117280	AK-735251	24402155	F8-7328	344511	F8-4100
0614411	F8-5639	13117280	F8-7699	24402155	F8-7328S	344511	F8-6324
0614426	F8-7089	13125635	F8-6978	24402155	F8-7625	344512	F8-4100
0682504	F8-5445	13159994	F8-6981	24403535	F8-7698	344512	F8-6324
0682545	F8-4092	13159995	F8-6982	24416545	F8-6753	344513	F8-5501
0684126	F8-5442	13159996	F8-6983	24459755	F8-6979	344513	F8-5501S
0684134	F8-6959	13167940	F8-6729	24459797	F8-6977	344514	F8-5501
0684160	F8-5441	13178147	F8-7329	2875013	F8-5333	344514	F8-5501S
0684168	F8-6217	13178147	F8-7330	302067	F8-6733	344514	F8-7973
0684238	F8-6753	13186959	F8-7327	302275	F8-6734	344515	F8-3026
0684248	F8-4093	13186959	F8-7328	302290	F8-6734	344516	F8-3026
0684262	F8-6883	13186959	F8-7328S	312503	F8-3027	344517	F8-5304
0684274	F8-6826	13186960	F8-7327	312503	F8-6319	344517	F8-5304S
0684275	F8-6826	13186960	F8-7328	312510	F8-6517	344518	F8-3025
0684282	F8-5372	13186960	F8-7328S	312510	F8-8085	344518	F8-5304S
0684283	F8-5468	13188763	F8-7329	312510	F8-8214	344519	F8-5450
0684285	F8-5467	13188763	F8-7330	34415	F8-5501S	344522	F8-5434
0684289	F8-5439	13189414	AK-735252	34416	F8-5501S	344523	F8-5448
0684291	F8-5438	13189414	F8-7662	344182	F8-5707	344523	F8-8085
0684294	F8-5437	13197623	F8-7661	344349	AK-735251	344524	F8-3025
0684641	F8-5436	13242433	F8-7612	344349	F8-7699	344524	F8-5304S
0684643	F8-5391	13242434	F8-7613	344401	F8-7584	344525	F8-5463
0684644	F8-5462	13243574	AK-735434	344402	F8-5710	344525	F8-8214
0684646	F8-5418	13243574	F8-7811	344409	F8-5964	344526	F8-7632
0684647	F8-5374	13251764	F8-7621	344411	F8-5692	344529	F8-7329
0684666	F8-5373	13257624	AK-735434	344416	AK-735251	344529	F8-7330
0684667	F8-5372	13257624	F8-7810	344416	AK-735252	344531	F8-5304S
0684669	F8-5371	13270705	F8-7172	344417	AK-735038	344536	F8-7329
0684670	F8-5370	13270705	F8-7328	344417	F8-5878	344536	F8-7330
0684692	F8-5368	13270705	F8-7328S	344418	F8-5966	344537	F8-7329
0684695	F8-6217	13270705	F8-7330	344419	AK-735254	344537	F8-7330
0684703	F8-5367	13276432	F8-7615	344420	AK-735254	344543	F8-7327
09156951	F8-6217	13315196	F8-7615	344421	F8-5913	344543	F8-7328
09191564	F8-6217	13315197	F8-7889	344424	F8-7698	344543	F8-7328S
0920 352	F8-6659	13500663	F8-7611	344426	AK-735253	344544	F8-7327
0920 355	F8-6659	13501413	F8-7616	344427	AK-735249	344544	F8-7328
0920 368	F8-6659	13503548	F8-7611	344435	AK-735251	344544	F8-7328S
0920352	F8-6659	13503549	F8-7611	344435	AK-735252	344565	F8-7328
0920355	F8-6659	13505131	F8-7616	344435	AK-735253	344565	F8-7328S
0920368	F8-6659	1603146	M-820820	344435	F8-7663	344565	F8-7625



OPEL		OPEL		OPEL		OPEL	
344573	F8-7616	352347	G9-594	4404592	F8-6684	5344026	F8-7810
344591	F8-7372	352348	G9-594	4405652	LM-10002S	5402630	F8-5335
344625	F8-7172	352349	G9-591	4408054	F8-6196	5402631	F8-5336
344625	F8-7328	352351	F8-5968	4408056	F8-7151	5402638	F8-7913
344625	F8-7328S	352351	G9-593	4408476	F8-6478	54310-00QABSK	F8-6197
344625	F8-7330	352352	F8-5969	4408746	F8-6692	55700767	AK-735251
344628	F8-7611	352352	G9-594	4408759	F8-6690	55700767	AK-735252
344645	AK-735254	352355	F8-4097	4408760	F8-6691	55700767	F8-7663
344651	F8-7661	352356	F8-5334	4408761	F8-6693	55701796	F8-7422
344653	F8-7421	352357	F8-4090	4410926SK	F8-6197	55703313	F8-7421
344665	F8-7172	352358	F8-5110	4411937	F8-7733	55703317	F8-7423
344665	F8-7328	352364	F8-4090	4411938	F8-7736	55703318	F8-7424
344665	F8-7328S	352365	F8-5130	4412907	F8-6661	5614427	F8-7869
344665	F8-7330	352457	F8-5109	4413748	F8-7652	5614437	F8-5639
344956	AK-735252	352458	F8-5108	4413749	F8-7652	5614444	F8-7089
344956	F8-7662	352864	F8-6729	4414115	F8-7652	5614450	F8-7872
344963	F8-7422	353280	F8-6038	4414116	F8-7652	5682504	F8-6826
344969	AK-735434	353281	F8-6037	4416894	F8-7737	5682505	F8-7850
344969	F8-7811	353460	F8-6656	4417573	F5-1036	5682507	F8-6739
350078	F8-5332	353560	F8-5101	4417574	F5-1025	5682508	F8-6740
350093	F8-7945	353561	F8-5128	4418051	F8-6691	5682510	F8-7850
350104	F8-7929	374050	M-822900	4420381	F8-8039	5682519	F8-8142
350112	F8-5143	374050	MK-822920	4421191	F8-7736	5684045	F8-5365
350113	F8-5144	402 952	F8-7944	444153	F8-5724	5684046	F8-6755
350116	F8-5331	402642	F8-3060	444160	F8-7919	5684048	F8-8155
350123	F8-5332	402643	F8-5552	444199	F8-5724	5684051	F8-8195
350127	F8-5228	402645	F8-4102	444200	F8-6660	5684052	F8-6836
350130	F8-5211	402649	F8-5911	444325	F8-5338	5684130	F8-6978
350138	F8-5230	402935	F8-4101	444336	F8-5338	5684134	F8-6657
350140	F8-7945	402942	F8-5337	444347	F8-5970	5684136	F8-6977
350145	F8-7925	423121	F8-5201	4500091	F8-6687	5684137	F8-6975
350147	F8-6091	423302	F8-6098	4500094	F8-6673	5684160	F8-6881
350153	F8-5333	423313	F8-4099	4500095	F8-6674	5684161	F8-7879
350161	F8-7926	423315	F8-5722	4500102	F8-6684	5684162	F8-6217
352300	G9-593	423316	F8-5723	4501260	LM-10032S	5684166	F8-8170
352301	G9-590	423318	F8-6098	4566899	F8-4090	5684168	F8-7794
352302	F8-5108	423320	F8-7373	458009	F8-4106	5684170	F8-7793
352303	F8-5109	424764	F8-7847	458014	F8-7053	5684171	F8-6944
352309	F8-5263	434030	AK-735255	458363	F8-6765	5684178	F8-6980
352310	F8-5262	436426	F8-7612	458364	F8-6766	5684179	F8-6979
352319	F8-6447	436427	F8-7613	458366	F8-6765	5684644	F8-6836
352320	F8-5262	436448	F8-7615	458367	F8-6765	5684652	F8-6981
352324	F8-7946	436503	F8-7615	4705409	F8-7857	5684653	F8-6982
352327	F8-5112	436504	F8-7889	4705409	F8-7857S	5684654	F8-6983
352330	G9-591	436551	F8-7621	4705518	AK-735247	5684655	F8-6984
352334	G9-591	436773	F8-7423	4705664	AK-735078	5684657	F8-6985
352335	G9-592	436774	F8-7424	4708282	F8-7624	614172	F8-7872
352338	F8-5107	436933	F8-5912	4708288	AK-735437	614426	F8-7089
352341	F8-4098	436940	F8-5611	4708288	F8-7326	614758	F8-7872
352342	F8-4097	436955	F8-5721	4805492	F5-1001	6204229	F5-1041
352343	F8-4097	4401403	LM-10002S	520738	LM-10059S	6204286	F5-1041
352346	G9-593	4402612	F8-6688	5344026	AK-735434	6204889	F5-1049



OPEL		OPEL		OPEL		OPEL	
682502	F8-8137	90 445 208	F8-5450	90343676	F8-4106	9231099	AK-735251
682504	F8-5445	90 468 554	F8-5448	90344692	F8-5374	9231099	AK-735252
682545	F8-4092	90112571	F8-7584	90345330	F8-5304S	9231099	F8-7663
682549	F8-8145	90121275	F8-3024	90372559	F8-4102	9266152	F8-6881
682556	F8-5444	90121275	F8-6324	90373771	F8-5724	93161258	F8-7652
682560	F7-2059	90125491	MK-822920	90373778	G9-593	93161259	F8-7652
682600	F8-8166	90125494	MK-822920	90374844	F8-3025	93168039	F8-8039
682601	F8-5444	90125889	F8-5710	90374844	F8-5304S	93170224	F8-7652
682603	F8-8166	90135318	F8-5952	90421747	MK-822920	93170225	F8-7652
684126	F8-5442	90147599	F8-5611	90425479	F8-3026	93190868	F5-1025
684134	F8-6959	90154756	F8-3059	90425479	F8-5501S	93191295	F8-7172
684160	F8-5441	90157161	F8-4094	90445097	G9-590	93191295	F8-7328
684168	F8-6217	90170695	F8-3027	90445207	F8-6319	93191295	F8-7328S
684173	F7-2059	90184728	F8-4093	90447528	F8-6826	93191295	F8-7330
684176	F8-7850	90184755	F8-5589	90447867	F8-5332	93193105	F8-7624
684180	F8-7794	90184756	F8-3059	90468568	F8-7372	93193111	AK-735437
684181	F8-7793	90189050	F8-3060	90468618	F8-6517	93193111	F8-7326
684188	F8-6203	90193117	G9-591	90468638	F8-5110	93743440	F5-1001
684226	F8-6835	90193760	F8-4092	90468644	AK-735038	96335966	G9-591
684238	F8-6753	90222781	F8-6766	90468644	F8-5878	97251975	F8-7089
684248	F8-4093	90223323	F8-6883	90470670	F8-7053	97361525	F8-7089
684249	F8-6974	90223456	F8-4099	90473848	F8-6959		
684262	F8-6883	90235040	G9-592	90495513	F8-6739		
684274	F8-6826	90235055	F8-6826	90495514	F8-6740		
684275	F8-6826	90235056	F8-6826	90495617	F8-5912		
684281	F8-5440	90236985	F8-3026	90496681	F8-5335		
684282	F8-5372	90236985	F8-5501S	90497363	F8-5966		
684283	F8-5468	90250986	F8-4101	90497969	F8-8183		
684285	F8-5467	90251358	F8-4100	90498740	F8-5130		
684289	F8-5439	90251358	F8-6324	90538063	F8-8166		
684291	F8-5438	90268463	G9-594	90538326	F8-3025		
684294	F8-5437	90268464	F8-5501	90538326	F8-5304S		
684641	F8-5436	90268464	F8-5501S	90538582	F8-8142		
684643	F8-5391	90278624	F8-5331	90538865	F8-5230		
684644	F8-5462	90279193	F8-4098	90538996	F8-5721		
684646	F8-5418	90279437	F8-4097	905751190	F8-6217		
684647	F8-5374	902825	LM-10045S	90575457	F8-6755		
684648	F8-5444	902825	M-822300	90575772	F8-8195		
684666	F8-5373	902825	MK-822300	90576351	F8-7847		
684667	F8-5372	902825	MK-822300	908554	F8-7632		
684669	F8-5371	902828	LM-10045S	91166315	F8-7151		
684670	F8-5370	902828	M-822300	9128177	F8-5639		
684684	F8-8183	902828	MK-822300	9156933	F8-8170		
684692	F8-5368	902828	MK-822300	9156951	F8-6217		
684693	F8-8071	90288082	G9-594	9191181	F8-7172		
684694	F8-6835	90288206	F8-4100	9191181	F8-7330		
684695	F8-6217	90288206	F8-6324	9191302	F8-5913		
684703	F8-5367	90288207	F8-4097	920 352	F8-6659		
684713	F8-8158	90288232	G9-593	920 368	F8-6659		
7701207491SK	F8-6197	90289411	F8-5964	920355	F8-6659		
846000	F8-8161	90289421	F8-5501	9227882	F8-8158		
8981675	F7-2054	90289421	F8-5501S	9227883	F8-8161		

PEUGEOT	
00000515P2	F8-5636
04333710	F8-5870
0515 Q8	F8-7861
0515 R5	F8-7862
0515.H3	F8-6395
0515.H6	F8-7084
0515.J3	F8-7643
0515.K1	F8-6394
0515.K4	F8-7079
0515.K6	F8-7083
0515.N0	F8-6394
0515.P1	F8-6394
0515.P5	F8-6394
0515.R0	F8-7082
0515.R2	F8-5660
0515.R4	F8-7644
0515.R8	F8-6394
0515.R9	F8-5660
0515.S1	F8-6394
0515.S2	F8-7874
0515.S4	F8-5660
0515.S9	F8-8112
0515.T1	F8-6571
0515.T1	F8-8112
0515.T3	F8-7645
0515.T4	F8-7081
0515.V4	F8-7082
0515.V8	F8-7082
0515G3	F8-5643
0515J9	F8-5647





PEUGEOT		PEUGEOT		PEUGEOT		PEUGEOT	
0515K4	F8-7863	182710	F8-5569	3520G9S1	F8-6153	3561.05	F8-6815
0515K9	F8-5646	182723	F8-5359	3520H5	F8-5355	3561.08	F8-5084
0515L6	F8-5644	1839.46	F8-6538	3521.C9S	F8-6154	3561.09	F8-6817
0515L8	F8-5636	1843.61	F8-6509	3521C9	F8-6154	3640.35	F8-5669
0515L9	F8-5636	1843.80	F8-6903	3523.14	F8-7994	3640.41	F8-5630
0515P2	F8-5636	1843.84	F8-6902	3523.16	F8-6816	3740.39	F8-7197
0515R2	F8-5660	1843.88	F8-6899	3523.20	G9-520	3740.39	G8-197
0515R9	F8-5660	1843.93	F8-6921	3523.23	F8-5072	3740.52	F8-7197
0515S4	F8-5660	1843.95	F8-5556	3523.25	G9-523	3740.52	G8-197
0515S9	F8-8112	1843.97	F8-5558	3523.25	G9-523S	4018.A5	LM-10018S
0515T1	F8-8112	1843.98	F8-6496	3523.27	F8-5078	4066.15	LM-10004S
0515V5	F8-5636	1843.99	F8-8199	3523.31	G9-525	4066.17	LM-10049S
0515V6	F8-5636	184399	F8-8199	3523.40	G9-547	4066.20	LM-10004S
1305782080	F8-5092	1844.17	F8-5558	3523.42	G9-549	4066.22	LM-10039S
1307021080	F8-5936	1844.36	F8-6500	3523.43	F8-5150	4066.31	LM-10018S
1316735080S	F8-6155	1844.41	F8-6496	3523.45	F8-5293	4066.32	LM-10014S
1316735080S1	F8-6153	1844.46	F8-6891	3523.49	F8-5078	4066.35	LM-10018S
1316736080S	F8-6154	1844.47	F8-5357	3523.49	G9-523	4066.41	LM-10022S
1318825080	F8-7164	1844.51	F8-6505	3523.49	G9-523S	4066.50	LM-10047S
1607114880	F8-7790	1844.54	F8-6904	3523.50	G9-556	4066.56	LM-10010S
1607690980	F8-6611	1844.58	F8-6898	3523.51	G9-555	4066.57	LM-10040S
1607690980	F8-7468	1844.66	F8-6898	3523.52	F8-5251	4066.73	LM-10040S
1608945780	F8-7791	1844.68	F8-6500	3523.53	F8-6143	4066.82	LM-10040S
1608947980	F8-7791	1844.75	F8-6497	3523.54	G9-549	4331968	G9-504
1608948080	F8-7791	1844.77	F8-6486	3523.59	F8-5248	5030.A1	F8-3012
1806.28	F8-8167	1844.82	F8-6508	3523.60	F8-5066	5030.A2	F8-3012
1806.33	F8-8184	1844.92	F8-6487	3523.61	F8-5099	5031.25	F8-5353
1806.59	F8-8141	1844.93	F8-8149	3523.67	F8-5293	5031.53	F8-5518
1806.69	F8-8169	1844.C0	F8-8202	3523.75	F8-5248	5031.54	F8-5519
1806.84	F8-8141	184425	F8-5568	3523.83	F8-5361	5031.55	F8-5353
1806.95	F8-6612	184436	F8-6500	3523.89	G9-549	5031.57	F8-6018
1806.96	F8-8141	184442	F8-5358	3523.91	F8-6134	5031.57	F8-6299
180628	F8-8167	184468	F8-6500	3523.93	F8-6115	5031.59	F8-6019
180659	F8-8141	184493	F8-8149	3523.93	F8-6452	5031.59	F8-7163
180669	F8-8169	1844C0	F8-8202	3523.94	F8-6114	5031.63	F8-5508
180684	F8-8141	1846.65	F8-6918	3523.98	F8-5629	5031.70	F8-5354
180696	F8-8141	1846.66	F8-6485	3523.99	F8-6537	5031.71	F8-5353
1807.28	F8-6905	1846.C1	F8-6712	3523.AA	F8-6535	5031.72	F8-5517
1807.45	F8-6854	2523.29	F8-5078	3523.AP	F8-6773	5031.73	F8-5516
1809.22	F8-6237	328769	F8-5356	352314	G9-521	5031.77	F8-6058
1809.28	F8-7011	329373	M-850850	352325	F8-5078	5031.A1	F8-6021
1809.30	F8-8184	329373	MK-850850	352364	F8-5251	5031.A2	F8-6020
180904	F8-5375	333207	F8-5806	352366	G9-556	5031.A3	F8-7492
180916	F8-5026	3502.77	F8-6276	352371	G9-525	503125	F8-7154
180921	F8-6236	3502.77	G8-276-501	352373	G9-520	503135	F8-5615
180930	F8-8184	3502.77	G8-276-502	352376	G9-698	503135	F8-6305
180933	F8-8184	3504.30	F8-6586	352377	G9-699	503148	F8-6305
1827.16	F8-6507	3520.G9S	F8-6155	352392	G9-699	503153	F8-6293
1827.17	F8-6520	3520.H5S1	F8-5355	352393	F8-6115	503155	F8-7154
1827.19	F8-6888	3520.HSS1	F8-5355	352393	F8-6452	503157	F8-6299
1827.22	F8-6857	3520G9	F8-6153	3525.05	F8-6452	503163	F8-6295
1827.33	F8-6897	3520G9	F8-6155	352505	F8-6452	503164	F8-6294



PEUGEOT		PEUGEOT		PEUGEOT		PEUGEOT	
503166	F8-6304	503523	F8-6299	5038.19	F8-8067	503824	F8-6296
503170	F8-6306	503523	F8-6302	5038.23	F8-5517	503825	F8-6026
503171	F8-6296	503527	F8-3012	5038.25	F8-7167	503828	F8-5353
503171	F8-7154	503527	F8-6292	5038.28	F8-8066	503828	F8-5354
503172	F8-6297	503527	F8-6293	5038.29	F8-8067	503828	F8-7468
503177	F8-6302	503527	F8-6294	5038.35	F8-6018	503828	F8-8066
503179	F8-7468	503527	F8-6295	5038.36	F8-6020	503829	F8-5353
503198	AK-735416	503527	F8-6296	5038.39	F8-6019	503829	F8-5354
503227	F8-5615	503527	F8-6297	5038.39	F8-7163	503829	F8-8067
503227	F8-6305	503527	F8-6299	5038.40	F8-6021	503835	F8-6299
503228	F8-5615	503527	F8-6302	5038.41	F8-8066	503841	F8-5354
503228	F8-6305	503529	F8-3014	5038.42	F8-5353	503841	F8-6306
5033.23	F8-5798	503529	F8-7164	5038.42	F8-8067	503841	F8-8066
5033.26	F8-6064	503530	F8-3023	5038.46	F8-6058	503842	F8-7154
5033.40	F8-5935	503530	F8-6306	5038.50	F8-5518	503842	F8-8067
5033.58	F8-6063	503530	F8-7154	5038.52	F8-5519	503846	F8-6058
5033.70	F8-7585	503532	F8-6305	5038.54	F8-6020	503846	F8-6302
5033.71	F8-6564	503538	F8-3014	5038.56	F8-6018	503850	F8-6293
5033.75	F8-6562	503538	F8-6304	5038.58	F8-6021	503852	F8-6292
5033.75	F8-7492	503538	F8-7164	5038.60	F8-6019	503856	F8-6299
5033.86	F8-7588	503539	F8-3023	5038.60	F8-7163	503862	F8-6296
5033.E4	F8-7848	503539	F8-6306	5038.66	F8-7167	503866	F8-6026
503339	AK-735091	503539	F8-7154	5038.72	F8-5354	503868	F8-5622
503339	F8-5936	503543	F8-3014	5038.72	F8-8066	503868	F8-6304
503340	AK-735064	503545	F8-3014	5038.74	F8-5353	503872	F8-6306
503340	F8-5935	503547	F8-3023	5038.74	F8-8067	503872	F8-8066
503358	F8-6063	503547	F8-6306	5038.85	F8-6058	503874	F8-7154
503370	AK-735068	503552	F8-6266	5038.87	F8-6610	503874	F8-8067
503371	F8-6564	503554	F8-6305	5038.89	F8-6611	503876	F8-5517
503396	AK-735416	503555	F8-3014	5038.A3	F8-6611	503876	F8-6297
5033A0	F8-7708	503555	F8-6304	5038.A4	F8-6610	503878	F8-5364
5033E3	F8-7849	503555	F8-7164	5038.C5	F8-6020	503878	F8-5516
5033E4	F8-7848	503557	F8-6266	5038.C6	F8-6021	503878	F8-6296
5034.47	F8-7468	5035-57	F8-7171	5038.C9	F8-6611	503885	F8-6302
503447	F8-7468	503558	F8-3012	5038.E3	F8-6610	503887	F8-7467
5035.23	F8-7163	503563	F8-3012	5038.E7	F8-7492	5038A4	F8-7467
5035.27	F8-7163	5035C2	F8-6266	5038.E7	F8-7493	5038A6	F8-7605
5035.27	F8-7492	5037.20	F8-5508	5038.GO	F8-6058	5038C1	F8-7170
5035.32	F8-6026	503720	F8-6295	503808	F8-6292	5038C1	F8-7171
5035.32	F8-6479	503723	F8-6294	503815	F8-5518	5038E2	F8-7468
5035.54	F8-6026	503726	F8-6294	503816	F8-6304	5038E3	F8-7467
5035.54	F8-6479	503726	F8-7153	503817	F8-7164	5038E6	F8-7605
503515	F8-6293	503733	F8-5520	503818	F8-5353	5038F3	F8-7467
503517	F8-3013	503733	F8-7154	503818	F8-6306	5038F4	F8-7468
503518	F8-5520	503735	F8-6294	503818	F8-8066	5038F5	F8-6516
503521	F8-6295	503735	F8-7153	503819	F8-7154	5038F6	F8-7170
503523	F8-3012	5038.08	F8-5519	503819	F8-8067	5038F6	F8-7171
503523	F8-6293	5038.16	F8-5622	503821	F8-5364	5038G7	F8-7428
503523	F8-6294	5038.17	F8-5621	503821	F8-6296	5038G8	F8-7429
503523	F8-6295	5038.18	F8-5354	503822	F8-5364	5038J7	F8-7429
503523	F8-6296	5038.18	F8-8066	503823	F8-6297	5038J8	F8-7428
503523	F8-6297	5038.19	F8-5353	503824	F8-5516	505443	F8-7490



PEUGEOT		PEUGEOT		PEUGEOT		PEUGEOT	
5094.36	F8-6793	5131.64	G8-275	5132.73	G8-276-502	5179.14	F8-6275
5094.37	F8-6794	5131.72	F8-5897	5133.22	F8-6274	5179.14	F8-6277
5094.40	F8-6795	5131.73	F8-5898	5133.22	F8-6275	5179.14	G8-248
5094.53	F8-7212	5131.80	F8-5830	5133.22	G8-274	5179.14	G8-275
5094.59	F8-6096	5131.93	F8-5989	5133.22	G8-275	5179.14	G8-277
5094.63	F8-5062	5131.94	F8-5990	5142.48	F8-7169	5210.20	F8-5612
5094.64	F8-5077	5131.96	F8-6248	514232	F8-6354	521034	AK-735417
5094.65	F8-5213	5131.96	F8-6276	5148.98	G8-276-501	525419	AK-735091
5094.69	F8-5092	5131.96	G8-248	514851	G8-276-502	525426	AK-735064
5094.74	F8-6130	5131.96	G8-276-501	514858	G8-274	525431	AK-735068
5094.77	F8-6128	5131.96	G8-276-502	514858	G8-275	525442	AK-735438
5094.80	F8-6127	5131.A4	F8-6591	514883	G8-276-501	525448	F8-7660
5094.81	F8-6125	5131.A5	F8-6592	514883	G8-276-502	541230	F8-6354
5094.82	F8-7975	5131.A6	F8-6277	514898	G8-276-502	9150018980	G9-521
5094.87	F8-6593	5131.A6	F8-7197	5151.24	F8-7043	91504248	G9-521
509466	F8-6129	5131.A6	G8-197	515110	F8-5566	91510633	F8-6293
509475	F8-6131	5131.A6	G8-277	515259	F8-5807	91510633	F8-6294
509479	F8-7943	5131.F6	F8-7790	515261	F8-5871	91510633	F8-6295
5102.CA	F8-7791	513154	F8-5835	515262	F8-6176	91510633	F8-6296
5102.EY	F8-7791	513155	F8-5836	5154.08	F8-6272	91510633	F8-6297
5102.FA	F8-7791	513156	F8-5837	5154.08	G8-272	91510633	F8-6299
5102.FC	F8-7791	513169	F8-5352	5154.09	F8-6272	91510633	F8-6302
5102.P8	F8-7791	513170	F8-5351	5154.09	G8-272	9151063380	F8-3012
5102.Q2	F8-7791	513171	F8-5363	5154.10	F8-6272	9151063380	F8-6292
5102.Q4	F8-7791	513178	F8-5828	5154.10	G8-272	9151063380	F8-6293
5102.T2	F8-7791	513179	F8-5829	5154.11	F8-6274	9151063380	F8-6294
5102.T3	F8-7791	513199	F8-5829	5154.11	F8-6275	9151063380	F8-6295
5102.T4	F8-7791	5132.49	F8-6272	5154.11	G8-274	9151063380	F8-6296
5102.T5	F8-7791	5132.49	G8-272	5154.11	G8-275	9151063380	F8-6297
5102.T6	F8-7791	5132.55	F8-6274	516120	F8-6386	9151063380	F8-6299
5102.T7	F8-7791	5132.55	G8-274	5166.63	F8-7589	9151063380	F8-6302
5102.T8	F8-7791	5132.56	F8-6275	5166.70	F8-7673	9151063380	F8-7163
5102.T9	F8-7791	5132.56	G8-275	5166.73	F8-7590	91535412	F8-5558
5131.43	F8-5855	5132.60	F8-6276	516673	F8-7590	9503035580	F8-6274
5131.45	F8-6272	5132.60	G8-276-501	516698	F8-7491	9503035580	F8-6275
5131.45	G8-272	5132.60	G8-276-502	5174.05	F8-6274	9503035580	G8-275
5131.46	F8-5870	5132.62	F8-6272	5174.05	F8-6275	95205626	F8-5557
5131.47	F8-5852	5132.62	G8-272	5174.05	F8-6277	9556384280	F8-6272
5131.48	F8-6276	5132.65	F8-6272	5174.05	G8-274	9556384280	G8-272
5131.48	G8-276-501	5132.65	F8-6277	5174.05	G8-275	95598362	G9-610
5131.48	G8-276-502	5132.65	F8-7197	5174.05	G8-277	95603308	G9-556
5131.49	F8-6248	5132.65	G8-197	5174.06	F8-6248	95603346	G9-610
5131.49	F8-6276	5132.65	G8-272	5174.06	G8-248	95603783	F8-6292
5131.49	G8-248	5132.65	G8-277	5174.07	F8-6275	9563609180	F8-6275
5131.49	G8-276-501	5132.66	F8-6248	5174.07	F8-6277	9563609180	G8-275
5131.49	G8-276-502	5132.66	G8-248	5174.07	G8-275	96.158.746	F8-6129
5131.53	F8-5872	5132.72	F8-6277	5174.07	G8-277	96033565	F8-5556
5131.62	F8-6023	5132.72	F8-7197	5174.08	F8-6248	9604183780	F8-5615
5131.63	F8-5799	5132.72	G8-197	5174.08	G8-248	9604183780	F8-6305
5131.64	F8-6274	5132.72	G8-277	5176.17	F8-6272	96050338	F8-6143
5131.64	F8-6275	5132.73	F8-6276	5176.17	G8-272	96051391	F8-5213
5131.64	G8-274	5132.73	G8-276-501	5179.14	F8-6248	96070064	F8-5312



**PEUGEOT**

96083570	F8-5271
96090345	F8-5516
96090345	F8-6296
96090346	F8-6297
96096727	G9-520
96104506	F8-5347
96106474	G9-558
96113432	G9-556
96117499	F8-5361
9612314180	F8-6276
9612314180	G8-276-501
9612314180	G8-276-502
9612314280	F8-6276
9612314280	G8-276-501
9612314280	G8-276-502
96133255	G9-610
96140317	F8-6293
9614031780	F8-5518
9614031780	F8-6293
96147479	F8-5351
96148480	F8-6143
9615871880	F8-5077
96165433	F8-5066
96172459	F8-5099
9621916980	F8-7589
96239153	G9-698
9627434580	F8-6274
96286665	G9-699
9636181080	F8-5629
9636924480	F8-6394
9640877080	F8-6535
9650485180	F8-7590
9650653380	F8-6394
9651502280	F8-7588
9652181980	F8-7673
9653771880	F8-6394
9654515580	F8-6354
9655703580	F8-6394
9658296580	F8-7169
96603308	G9-556
9676408280	F8-7849
9680506880	F8-7708
97521102	F8-5555

**PORSCHE**

171407181A	G9-540
171407182D	G9-541
171412135	F8-5694
171419831	LM-10024S
171419831	LM-10050S
171419831B	LM-10024S
171419831B	LM-10050S
171419831C	LM-10024S

**PORSCHE**

171419831C	LM-10050S
171419832	LM-10064S
171419832A	LM-10064S
171419832C	LM-10064S
92833351810	AK-735158
95134352700	AK-735166
95134352901	AK-735166
95533310520	AK-735168
95534102700	F8-6705
95534102701	F8-6705
95534102702	F8-6705
95534113301	F8-8131
95534124203	F8-6706
95534124204	F8-6706
95534158810	F8-6707
95534324301	F8-5301
95534350500	AK-735168
95534719110	LM-10100S
96433310500	AK-735159
96433310600	AK-735159
96433350201	AK-735158
96434330100	AK-735157
96434330100	AK-735160
96434350500	AK-735157
98633330101	AK-735167
98633350501	AK-735167
98633350501	AK-735169
98733330100	AK-735169
99333310500	AK-735161
99333310701	AK-735161
99333310701	AK-735163
99333310701	AK-735164
99333310701	AK-735165
99334350500	AK-735160
99633310501	AK-735165
99633310502	AK-735163
99633310503	AK-735164
99634330102	AK-735162
99634350500	AK-735162
99660315250	F5-1086
99760315400	F5-1086

**RENAULT**

112107695R	F8-6711
4410926SK	F8-6197
46414183	F8-5514
5000387455	F8-6848
5000387990	F8-5091
5000392656	F8-6685
5000392657	F8-6686
540500001R	AK-735419
540500016R	AK-735444
54310-00QABSK	F8-6197

**RENAULT**

543250005R	F8-7637
543251867R	F8-7637
543256557R	F8-7637
6000025363	LM-10036S
6000025546	LM-10000S
6000025597	LM-10036S
6001009755	F8-5500
6001009755	F8-6378
6001025850	F8-3032
6001025850	F8-6329
6001025850	F8-6339
6001025850	F8-6376
6001547499	F8-6339
6001547499	F8-6596
6001547607	LM-10032S
6001547893	F8-6711
6001548160	F8-6600
6001548402	F8-7900
6001549205	F8-8157
6001549290	F8-7900
6025000245	F8-5802
6025000249	F8-5803
6025102324	F8-6876
6025102333	F8-6875
6025304389	F8-6907
6025305979	F8-6333
6025305980	F8-7157
6025311529	F8-7993
6025315757	F8-5802
6025370231	LM-10032S
6040002245	F8-7977
77 00 302 439	F8-6673
77 00 419 236	F8-5253
77 00 419 249	F8-5253
77 00 422 529	F8-6488
77 00 426 193	F8-6484
77 00 428 936	F8-6481
77 00 437 854	F8-6598
77 00 759 732	F8-6504
77 00 760 571	F8-5617
77 00 783 016	F8-6504
77 00 783 018	F8-6489
77 00 805 733	F8-6495
77 00 817 782	F8-6502
77 00 832 256	F8-6483
7700 302 440	F8-6674
7700104292	F8-5648
7700109260	F8-7654
7700110616	F5-1029
7700110616	F5-1061
7700115309	F8-5656
7700302115	F8-6687

**RENAULT**

7700302122	F8-6673
7700302123	F8-6674
7700302152	F8-6684
7700308756	F8-6688
7700411189	F8-6906
7700411638	F8-5536
7700411949	F8-6874
7700412094	F8-6877
7700413614	F8-5490
7700414099	F8-5489
7700414580	F8-6878
7700415087	F8-8188
7700415728	F8-7450
7700418941	F8-5253
7700419475	F8-7449
7700424399	F8-5253
7700424481	F8-6177
7700424481	F8-7633
7700424482	F8-7469
7700425757	F8-8146
7700426450	F8-5488
7700426450	F8-6376
7700428440	F8-5863
7700429441	F8-6174
7700434370	F8-5487
7700437391	F8-8146
7700500113	F8-7052
7700518392	F8-6818
7700518856	F8-6818
7700653459	LM-10055S
7700656569	LM-10013S
7700667186	F8-5096
7700678649	LM-10001S
7700678649	LM-10042S
7700693154	F8-6798
7700702890	F8-6866
7700706007	LM-10002S
7700724249	F8-5645
7700730733	F8-5805
7700745290	F8-5486
7700745515	G9-571
7700748646	F8-6839
7700754515	G9-571
7700755531	F8-6913
7700757324	F8-5500
7700757324	F8-6378
7700757691	F8-5499
7700759497	F8-6875
7700759498	F8-6875
7700760264	F8-5090
7700760265	F8-5098
7700760488	F8-6841



### RENAULT

7700760510	F8-6841
7700762574	G9-570
7700762721	F8-6864
7700762843	F8-6079
7700762844	F8-6156
7700763207	F8-6871
7700763934	F8-6789
7700765840	F8-5068
7700765935	F8-6865
7700766126	F8-6863
7700766389	F8-5499
7700766389	F8-6222
7700767684	F8-5785
7700767685	F8-5786
7700767686	F8-7044
7700768010	F8-6876
7700769075	F8-7173
7700769226	F8-6797
7700769719	F8-6909
7700769720	F8-6908
7700770307	F8-6842
7700770479	F8-6843
7700770480	F8-6844
7700771543	F8-5499
7700771562	F8-6788
7700771949	F8-6845
7700772687	G9-598
7700773245	F8-6799
7700773881	F8-5499
7700774026	F8-6790
7700776743	AK-735042
7700777276	F8-6802
7700777540	F8-5068
7700777654	F8-3033
7700777654	F8-6222
7700777654	F8-6331
7700777654	F8-6378
7700777654	F8-6379
7700779772	F8-7045
7700780875	F8-5473
7700780875	F8-6379
7700781095	LM-10002S
7700781097	LM-10001S
7700781097	LM-10042S
7700781441	F8-6116
7700781463	F8-5111
7700781464	F8-6116
7700784170	F8-6796
7700784171	F8-7942
7700785788	F8-5085
7700785929	F8-5086
7700785949	F8-4109

### RENAULT

7700785950	F8-4110
7700788318	F8-5485
7700789477	G9-653
7700789478	G9-569
7700789815	F8-5088
7700793723	F8-5850
7700793723	F8-6331
7700794601	F8-5482
7700795187	F8-5499
7700795687	F8-4109
7700795688	F8-5484
7700795689	F8-5483
7700797654	F8-3033
7700797654	F8-6331
7700797654	F8-6378
7700797654	F8-6379
7700797666	F8-3033
7700797666	F8-6222
7700797666	F8-6331
7700797666	F8-6378
7700797666	F8-6379
7700797821	F8-6221
7700798053	F8-5088
7700798900	F8-5488
7700798900	F8-6376
7700798900	F8-8088
7700799064	G9-568
7700799065	G9-567
7700799066	F8-5125
7700799404	F8-5087
7700800107	F8-3032
7700800107	F8-5813
7700800107	F8-6329
7700800107	F8-6339
7700800107	F8-6376
7700800107S	F8-5813
7700800522	F8-5349
7700800976	F8-5088
7700801543	F8-5482
7700802667	AK-735257
7700802667	F8-5863
7700802927	F8-5481
7700803635	F8-3012
7700803635	F8-6222
7700803635	F8-6331
7700804163	F8-4110
7700805120	F8-5472
7700805123	F8-5480
7700805733	F8-4110
7700805922	F8-5620
7700806238	G9-677
7700806239	G9-676

### RENAULT

7700809945	F8-6669
7700818369	F8-5464
7700818371	F8-5478
7700818372	F8-5478
7700818994	F8-6873
7700819237	F8-5862
7700819415	LM-10001S
7700819415	LM-10042S
7700819502	F8-7341
7700819928	G9-604
7700819929	G9-603
7700820501	F8-5488
7700820501	F8-6376
7700821159	AK-735256
7700821159	F8-5800
7700821167	F8-5810
7700821670	F8-6861
7700822503	G9-674
7700824022	F8-3033
7700824022	F8-6331
7700824022	F8-6378
7700824042	G9-675
7700827435	F8-5389
7700827435	F8-6376
7700827436	F8-5492
7700827436	F8-5813
7700827436S	F8-5813
7700828866	F8-5488
7700828866	F8-6376
7700829529	F8-5496
7700829529	F8-6329
7700829529	F8-8088
7700831364	G9-604
7700832262	F8-5472
7700832264	F8-5476
7700832419	F8-5475
7700832420	F8-5474
7700833302	F8-6878
7700833756	AK-735060
7700834940	F8-7341
7700835254	F8-5473
7700835254	F8-6379
7700835929	F8-5086
7700839316	F8-6174
7700840056	F8-5801
7700840234	F8-5850
7700840234	F8-6331
7700840741	G9-569
7700841531	F8-6862
7700846916	F8-5801
7700847383	F8-6786
7700849715	F8-5472

### RENAULT

7700853470	F8-7091
7700858731	F8-7090
7701055871	F5-1014
7701066401	F5-1096
7701207491	F8-6197
7701207491SK	F8-6197
7701207537	F8-6177
7701207678	F8-6195
7701207678SK	F8-6195
7701207807	F5-1014
7701207815	F8-6331
7701208582	F8-6338
7701208591	F8-6525
7701208591	F8-7057
7701208823	F8-7057
7701208891	F8-6195
7701208891	F8-6335
7701209534	G8-559
7701348568	M-850850
7701348568	MK-850850
7701348598	G9-521
7701349064	F8-5071
7701450617	M-870870
7701450617	MK-870870
7701462100	M-860860
7701462100	MK-860860
7701462308	M-860860
7701464320	F8-6278
7701464321	F8-6097
7701468575	M-860860
7701468576	M-860860
7701469389	M-870870
7701469389	MK-870870
7701469486	LM-10009S
7701469487	LM-10028S
7701469496	LM-10000S
7701469497	LM-10001S
7701469497	LM-10042S
7701469617	LM-10002S
7701469657	LM-10036S
7701470088	F8-6376
7701470361	LM-10032S
7701470567	M-860860
7701471141	LM-10057S
7701473334	F8-6478
7701476465	F5-1062
7701477502	F5-1014
7701477507	F5-1036
7701477508	F5-1025
7701477689	F5-1029
7701477689	F5-1061
7704000681	G9-570



**RENAULT**

7704000767	F8-6867
7704000769	F8-6868
7704000777	F8-6869
7704000829	F8-6870
7704000983	F8-6846
7704001091	F8-5860
7704001319	F8-6864
7704001320	F8-6910
7704002466	F8-5074
7704002468	F8-5068
7705040002	G9-600
82 00 039 132	F8-6661
82 00 148 388	F8-6482
82 00 150 759	F8-7905
82 00 171 178	F8-6598
82 00 346 941	F8-6662
82 00 346 942	F8-6662
82 00 431 675	F8-6661
82 00 696 437	F8-6662
82 00 839 121	F8-8070
8200000002	F8-7009
8200000514	F8-6671
8200000515	F8-6672
8200002868	F8-7990
8200002869	F8-7988
8200002876	F8-6177
8200002876	F8-6332
8200003824	F8-6690
8200003825	F8-6691
8200003826	F8-6693
8200003827	F8-6692
8200010493	F8-6196
8200010494	F8-6689
8200010518	F8-7151
8200014931	F8-8168
8200022596	F8-6675
8200024454	F8-6684
8200027176	F8-6524
8200038243	F8-6679
8200040073	AK-735061
8200041166	F8-7989
8200042453	F8-6680
8200042454	F8-8162
8200042456	F8-7746
8200042594	F8-6174
8200049243	F8-7736
8200065989	F8-7733
8200103263	F8-6676
8200106131	F8-6195
8200106131	F8-6335
8200113636	F5-1062
8200113636	F5-1095

**RENAULT**

8200125710	F8-6254
8200127285	AK-735258
8200127321	F8-6665
8200127324	F8-6664
8200151995	F8-8151
8200155207	F8-8138
8200170362	F8-8172
8200180137	AK-735062
8200181589	F8-6668
8200183567	F8-6338
8200183568	F8-6525
8200183569	F8-6523
8200183570	F8-6662
8200185800	F8-5657
8200197452	F8-6682
8200197453	F8-6681
8200200017	F8-6338
8200200017	F8-7057
8200200017	F8-7152
8200207436	F8-7092
8200213058	F8-7092
8200222463	F8-6175
8200222463	F8-6195
8200242025	F8-7992
8200250743	F8-6667
8200264322	F8-6676
8200267625	F8-8172
8200267867	F8-7653
8200268426	F8-7093S1
8200272424	F8-6676
8200277791	F8-8146
8200297936	F8-7093S1
8200297939	F8-6599
8200302003	F8-6666
8200307941	F8-6339
8200307941	F8-6596
8200325283	F8-6677
8200338372	F8-7746
8200338381	F8-6420
8200338385	F8-6522
8200346941	F8-6523
8200346942	F8-6523
8200355673	F8-6678
8200361247	F8-7657
8200367493	F8-6666
8200378211	F8-6691
8200380965	F8-6670
8200386445	F8-5645
8200389766	AK-735259
8200392683	F8-7094
8200392697	F8-5657
8200395313	F8-7646

**RENAULT**

8200395661	F8-6600
8200399188	F8-6683
8200404271	F8-7737
8200411123	AK-735260
8200427869	F8-8227
8200452699	AK-735259
8200457775	F8-7093
8200457775	F8-7093S1
8200468081	F8-7092
8200477938	F8-7732
8200489514	F5-1110
8200504291	F8-6526
8200504295	F8-6525
8200523072	F8-7093
8200523072	F8-7093S1
8200549046	F8-6420
8200555547	F8-7092
8200557552	F8-7450
8200575641	F8-8157
8200584039	F5-1036
8200585734	F8-6195
8200585734	F8-6335
8200591283	F8-7635
8200591288	AK-735446
8200592642	F8-7746
8200597259	F8-8227
8200619927	F8-7656
8200651172	F8-3032
8200651172	F8-6339
8200651172	F8-6376
8200651172	F8-8088
8200664348	F8-7092
8200687605	F8-7655
8200714955	G8-559
8200714956	F8-8227
8200714956	G8-559
8200725253	F8-7736
8200742906	F8-6715
8200757150	F8-6339
8200757150	F8-6596
8200767762	F8-7657
8200802664	F8-7092
8200805671	F8-8039
8200808455	F8-7450
8200824774	F8-6195
8200824774	F8-6335
8200839121	F8-8070
8200948647	F8-6338
8200948647	F8-7057
8200948647	F8-7152
8671017900	F8-6376

**ROVER**

**ROVER**

52385-SR3-000	F8-5988
EAP7162	AK-735397
EGP1673	F8-5123
GSV1153	LM-10035S
RBX101760	F8-8037
RBX101761	F8-8003
RBX101770	F8-8036
RBX101771	F8-8004
RGX10007	F8-5988
RGX100980	F8-5988
RNE10001	AK-735397
RNE100040	AK-735401
RNE100050	AK-735401
RNE100060	AK-735398
RNE100060	AK-735402
RNE100090	AK-735399
RNH100130	AK-735403
RNH100170	AK-735399
RNH100180	AK-735403
RPC100020	AK-735398
RPC100020	AK-735400
RPG100060	AK-735400
RPY100010	AK-735402

**SAAB**

0352357	F8-4090
12759389	AK-735263
12770367	F8-7888
12781136	F8-6098
12786062	AK-735262
12786412	F8-6447
12793902	F8-7329
12793902	F8-7330
24435884	F8-7329
24435884	F8-7330
24469643	F8-7373
4246062	F8-6656
4246112	F8-5333
4246377	F8-6267
4283891	F8-6823
4483632	F8-7147
4483897	AK-735074
4544276	F8-7147
4545711	F8-6547
4565180	AK-735072
4566899	F8-4090
4567244	F8-5201
4623146	F8-7026
4623153	F8-6824
4671434	F8-6830
4899985	F8-6831
4908562	F8-6327
4909701	F8-6267



SAAB		SEAT		SEAT		SEAT	
4947345	F8-6831	045903119A	F5-1085	191419883	F8-5145	1J0411314R	F8-5221
4967295	F8-7887	050129761A	F8-3048	191422831	F8-4075	1J0411314T	F8-5220
4967634	F8-7888	050129761B	F8-3048	191422831	LM-10003S	1J0411327	F8-5382
4967694	F8-7888	050129761F	F8-3048	191422831	LM-10006S	1J0412131	F8-6012
5 390 646	MK-810160	050129761H	F8-3048	191498203C	MK-830220	1J0412131B	F8-6013
5060892	F8-6327	06A105243E	F8-5650	191501541	F8-1010	1J0412131C	F8-6007
5064431	F8-6823	06B903119D	F5-1044	191512131	F8-5594	1J0412249	F8-3039
5232863	AK-735072	07635775	F8-5958	191512131B	F8-5594	1J0412249	F8-6280
5235247	F8-7884	1011898	F8-5995	191512333	F8-5403	1J0412303	F8-6041
5239140	F8-7888	1044571	G9-664	191512333	F8-6382	1J0412319C	F8-7133
55700767	AK-735262	113501149	F8-4080	191512333S	F8-6382	1J0412331	F8-4067
55700767	F8-7663	171253147	F8-4027	191512335	F8-5402	1J0412331	F8-6280
7551104	F8-7885	171253147A	F8-4027	191512335	F8-6382	1J0412331B	F8-4067
7592975	F8-7886	171419831B	F8-4069	191512335S	F8-6382	1J0412331B	F8-6280
8661476	G9-643	171498203	MK-830220	191513425	F8-5747	1J0412331C	F8-4067
8786006	F8-7886	175422831	F8-4075	1H0199233A	F8-5672	1J0412331C	F8-6280
8953986	F8-5226	176412303A	F8-4063	1H0199262A	F8-1011	1J0422831	LM-10020S
8958084	AK-735075	176412326	F8-1009B	1H0199262B	F8-4016	1J0422831B	LM-10020S
8961476	G9-643	176412329	F8-1009B	1H0199262E	F8-4017	1J0501541C	F8-5340
8965252	G9-641	176412329A	F8-1009B	1H0199262F	F8-1011	1J0501541D	F8-6076
8965253	G9-641	191199233	F8-5554	1H0199262G	F8-4016	1J0501541DS	F8-6077
8972002	AK-735075	191199262A	F8-1003	1H0199262H	F8-4016	1J0501541DS1	F8-6077
9156933	F8-8170	191199262C	F8-1025	1H0199402	F8-1015	1J0505145B	F8-7046
9191181	F8-7172	191199279B	F8-1004	1H0199402A	F8-1015	1J0512131	F8-6012
9191181	F8-7330	191199279C	F8-1004	1H0199609B	F8-3053	1J0512131B	AK-735095
		191199279D	F8-1004	1H0199609E	F8-5398	1J0512131B	F8-6013
		191199279E	F8-1005	1H0199609F	F8-5397	1J0512131C	F8-6007
		191199279F	F8-1005	1H0199609G	F8-5346	1J0512149B	F8-5381
		191199381A	F8-6922	1H0199609H	F8-5396	1J0513353B	F8-5380
		191199402A	F8-1006	1H0199609J	F8-5396	1J0513353C	F8-5380
		191199402C	F8-1006	1H0411314	F8-5395	1J0513353D	F8-6040
		191253147C	F8-4027	1H0412303A	F8-4063	1J0513353G	F8-5380
		191407181A	F8-1007	1H0412303B	AK-735039	1J0513425	AK-735409
		191407181A	F8-1007S	1H0412303B	F8-5996	1J0513425	F8-6044
		191407181B	F8-1007	1H0422831B	F8-4075	1J0513425A	AK-735095
		191407181B	F8-1007S	1H0422831B	LM-10003S	1K0 199 262 AT	F8-6528
		191407181D	F8-1008	1H0422831B	LM-10006S	1K0 511 353 J	F8-7579
		191407181E	F8-1008	1H0501541A	F8-4008	1K0 511 353 Q	F8-7580
		191407182	G9-648	1H0501541A	F8-4008S	1K0199231J	F8-6425
		191407285F	F8-7722	1H0512149	F8-5393	1K0199232J	F8-6424
		191411314	F8-3042	1J0 411 336 B	F8-6579	1K0199262AC	F8-6988
		191411329	F8-4060	1J0 411 336 C	F8-6579	1K0199262AJ	F8-6531
		191412135	F8-4064	1J0 411 336 D	F8-6579	1K0199262AL	F8-6988
		191412249	F8-3036	1J0199262BE	F8-5390	1K0199262AS	F8-7958
		191412303	F8-4063	1J0199262BK	F8-5388	1K0199262CG	F8-7959
		191412303A	F8-4063	1J0199262P	F8-6960	1K0199262L	F8-6988
		191412303C	F8-4063	1J0199429	F8-5907	1K0199262M	F8-6989
		191412329	F8-1009B	1J0199555AH	F8-5387	1K0199555L	F8-7960
		191412331	F8-1009B	1J0199555AJ	F8-5386	1K0199555N	F8-7961
		191419831	F8-4069	1J0199555AL	F8-5384	1K0199555Q	F8-7962
		191419831	LM-10024S	1J0407181	G9-649	1K0199555T	F8-8152
		191419831	LM-10050S	1J0411314AC	F8-7927	1K0199855BA	F8-7965

Alle in diesem Katalog genannten Original-Nummern der Kfz-Hersteller sind ausschließlich zu Vergleichszwecken bestimmt und dürfen in Rechnungen an Wagenbesitzer nicht verwendet werden.  
 All original numbers from automobile manufacturers listed in this catalogue are for comparison purposes only and may not be used in invoices to car owners.  
 Nachdruck, auch auszugsweise, nur mit unserer schriftlichen Genehmigung gestattet. - Full or partial reproduction only permitted with our approval.  
 Les références des constructeurs n'ont aucune valeur et ne sont indiquées qu'à titre d'identification. La reproduction complète ou partielle de notre catalogue est interdite sans notre accord écrit.



SEAT		SEAT		SEAT		SEAT	
1K0199855BB	F8-7966	357412303E	F8-4063	6N0412331A	F8-5494	6Q0512131B	F8-6723
1K0199867Q	F8-7981	357412303F	F8-5993	6N0412331A	F8-5523	6Q0512131C	F8-7658
1K0199868Q	F8-7982	357412331A	F8-1034	6N0412331AS	F8-5523	6R0199555	F8-7957
1K0407182	F8-5633	357412331AS	F8-1034S	6N0412331D	F8-5537	6R0412249	F8-3039
1K0407182A	F8-5633	357412331AS1	F8-1034S	6N0412331D	F8-6281	6R0412249	F8-6280
1K0407183A	F8-6736	357412341A	F8-5580	6N0412331E	F8-5537	6R0501541A	F8-5340
1K0407183E	F8-6736	357413175A	AK-735039	6N0412331E	F8-6281	6R0513353B	F8-5380
1K0407183G	F8-7991	357413175A	F8-5683	6N0413175A	AK-735264	6X0411313	F8-6190
1K0407183L	F8-6736	357422831	F8-4075	6N0413175A	F8-7132	6X0411313A	F8-6191
1K0412303B	F8-7131	357422831A	LM-10003S	6N0419831	F8-5061	6X0512131A	F8-6002
1K0412303E	AK-735264	357422831A	LM-10006S	6N0419831	LM-10088S	7201848	F8-1034
1K0412303E	F8-7809	357422831B	F8-4076	6N0501541D	F8-5341	7201848S1	F8-1034S
1K0412303F	F8-7697	377412335A	F8-3036	6N0501541D	F8-5341S	7403748	F8-5530
1K0412303H	F8-7834	3A0199402	F8-3041	6N0501541E	F8-7938	7635775	F8-5958
1K0412331B	F8-6284	3C0199231D	F8-6701	6N0512131A	F8-6004	7M0399201BQ	F8-8150
1K0412331B	F8-6570	3C0199231E	F8-6701	6Q0 199 167 BC	F8-6532	7M0407181A	G9-664
1K0412331C	F8-6284	3C0513353	F8-7603	6Q0 199 167 CA	F8-6533	7M0411031	F8-5407
1K0412331C	F8-6570	3C0513353C	F8-7603	6Q0199167BM	F8-5551	7M0412303B	F8-5995
1K0505171C	F8-7902	3C0513353D	F8-7603	6Q0199167BN	F8-6752	7M0413175A	F8-7688
1K0505203A	F8-7907	3C0513425	F8-6044	6Q0199167BQ	F8-5535	7M0422831B	F8-5051
1K0505279A	F8-7908	3C0513425B	F8-7845	6Q0199167CB	F8-5535	7M0422831B	LM-10023S
1K0505541D	F8-6463	4288726	G9-506	6Q0199167CC	F8-6945	7M0501541	G9-665
1K0505553 A	F8-7909	4400895	F8-3017	6Q0199167CE	F8-6945	7M0505221C	F8-5530
1K0511327AP	F8-7930	4A0253147	F8-4026	6Q0199167CL	F8-6752	7M3 498 201	MK-810160
1K0511327AR	F8-7923	4A0253147A	F8-4026	6Q0199167CS	F8-6945	7M3 498 201A	MK-810160
1K0511353N	F8-7601	4D0407182G	F8-4045	6Q0199167DH	F8-7952	7M3399201H	F8-7049
1K0511353Q	AK-735265	4D0412137B	F8-7687	6Q0199167DK	F8-6945	7M3399201K	F8-7032
1K0511353S	F8-7835	4D0412137C	F8-7687	6Q0199167DL	F8-6752	7M3422831	F8-5051
1K0513353G	F8-6348	4F0 512 131	F8-7578	6Q0199167J	F8-6986	7M3422831	LM-10023S
1K0513353R	F8-7603	4F0513353D	F8-6352	6Q0199555AB	F8-8173	7N0511359	F8-7815
1K0513425A	AK-735265	535199262	F8-1025	6Q0199555AD	F8-8164	7N0511359A	F8-7816
1K0513425A	F8-7640	6K0501541A	F8-7938	6Q0199555AE	F8-8173	803498203	MK-822920
1S0412303	F8-7891	6K0512131A	F8-6006	6Q0199555AR	F8-7951	811412323	F8-1027
1S0412303A	F8-7892	6K0512131B	F8-6008	6Q0199555AS	F8-8164	811412323C	F8-1027
1S0511351B	F8-7893	6LL407183	F8-7448	6Q0199555AT	F8-8173	811412323D	F8-1027
1S0513425A	F8-7486	6N0199262G	F8-7948	6Q0199851AB	F8-5534	817253147	F8-4026
3266405	F8-3036	6N0199262L	F8-5540	6Q0199851AJ	F8-7955	823253147A	F8-4026
357199279	F8-3040	6N0199555AA	F8-6923	6Q0199851AK	F8-7949	823253147D	F8-4026
357199279B	F8-3040	6N0199555G	F8-6923	6Q0199851AL	F8-7954	823407181	F8-4042
357199279C	F8-1004	6N0199555H	F8-8189	6Q0199851AP	F8-7956	823412249	F8-3036
357199381	F8-5491	6N0407181	F8-5105	6Q0199851AQ	F8-7950	883412249	F8-3036
357199381C	F8-5491	6N0407182	F8-5104	6Q0199851M	F8-5533	8A0253147A	F8-4027
357199402	F8-1015	6N0412249B	F8-6281	6Q0199851S	F8-5532	8A0412323B	F8-1027
357199402A	F8-3041	6N0412249B	F8-6569	6Q0407182A	F8-7873	8A0412323D	F8-1027
357199402B	F8-1015	6N0412249C	F8-6281	6Q0411314J	F8-6462	8D0 412 131 H	F8-7577
357199402C	F8-3041	6N0412249C	F8-6284	6Q0411314L	F8-6462	8D0407515C	F8-7796
357407181	F8-1008	6N0412249C	F8-6569	6Q0411314N	F8-6460	8E0199382A	F8-8171
357407182	G9-648	6N0412249D	F8-6281	6Q0411314P	F8-6462	8E0199382AA	F8-8171
357407182F	F8-7978	6N0412249D	F8-6284	6Q0411314R	F8-6460	8E0199382AH	F8-8171
357412135	F8-4064	6N0412249D	F8-6569	6Q0412301	F8-7675	8E0199382J	F8-8171
357412249	F8-3039	6N0412303A	F8-7830	6Q0412301A	F8-7676	8E0199382Q	F8-8171
357412249A	F8-3039	6N0412331	F8-5494	6Q0501541E	F8-7928	8E0407181C	F8-6151





SEAT	
8E0412377	F8-7451
8E0412377C	F8-7451
8E0505203D	F8-8133
8E0512137E	F8-7682
8N0407181B	F8-6464
8N0422831	LM-10020S
8Z0411314B	F8-7914
8Z0412331	F8-5537
8Z0412331	F8-6281
SE021156017A	F8-3036
SE022154805B	F8-6912
SE138154605A	F8-6928
SE141156137A	G9-506
SE141156228	F8-5958
SE141156228A	F8-5957

SKODA	
007296377	F8-5291
007296379	F8-5290
028 105 243AC	F8-6398
028903119AN	F5-1008
028903119AP	F5-1010
028903119AQ	F5-1007
028903119S	F5-1010
028903119T	F5-1008
038 105 243	F8-7864
038105243	F8-6392
038105243F	F8-6391
038105243K	F8-6392
038105243M	F8-6572
038903119	F5-1009
038903119M	F5-1006
038903119P	F5-1002
038903119T	F5-1004
03C903119C	F5-1064
03C903119D	F5-1064
03C903119F	F5-1064
03D903119A	F5-1000
03G 105 243B	F8-6573
03G105243	F8-6396
03G105243C	F8-6396
045105243	F8-8038
045105243C	F8-8038
045903119A	F5-1085
06A105243E	F8-5650
06B903119D	F5-1044
115395801	F8-7099
115422290	G9-678
115422291	G9-679
115422292	G9-680
191407182	G9-648
1H0412303B	AK-735039
1H0412303B	F8-5996

SKODA	
1J0 411 336 B	F8-6579
1J0 411 336 C	F8-6579
1J0 411 336 D	F8-6579
1J0199262BE	F8-5390
1J0199262BK	F8-5388
1J0199262P	F8-6960
1J0199429	F8-5907
1J0199555AH	F8-5387
1J0199555AJ	F8-5386
1J0199555AK	F8-5385
1J0199555AL	F8-5384
1J0407181	G9-649
1J0411314P	F8-7901
1J0411314R	F8-5221
1J0411314S	F8-5215
1J0411314T	F8-5220
1J0411327	F8-5382
1J0412131	F8-6012
1J0412131B	F8-6013
1J0412131C	F8-6007
1J0412249	F8-3039
1J0412249	F8-6280
1J0412303	F8-6041
1J0412319C	F8-7133
1J0412331	F8-4067
1J0412331	F8-6280
1J0412331B	F8-4067
1J0412331B	F8-6280
1J0412331C	F8-4067
1J0412331C	F8-6280
1J0422831	LM-10020S
1J0422831B	LM-10020S
1J0501541C	F8-5340
1J0501541D	F8-6076
1J0501541DS	F8-6077
1J0501541DS1	F8-6077
1J0505145B	F8-7046
1J0512131	AK-735267
1J0512131	F8-6012
1J0512131B	AK-735095
1J0512131B	F8-6013
1J0512131C	F8-6007
1J0512149B	F8-5381
1J0513353B	F8-5380
1J0513353C	F8-5380
1J0513353D	F8-6040
1J0513425	AK-735266
1J0513425	AK-735267
1J0513425	AK-735409
1J0513425	F8-6044
1J0513425A	AK-735095
1J0513425A	F8-6045

SKODA	
1K0 199 262 AT	F8-6528
1K0 511 353 P	F8-7600
1K0199231J	F8-6425
1K0199232J	F8-6424
1K0199262AC	F8-6988
1K0199262AJ	F8-6531
1K0199262AK	F8-6991
1K0199262AL	F8-6988
1K0199262AS	F8-7958
1K0199262CG	F8-7959
1K0199262K	F8-6991
1K0199262L	F8-6988
1K0199262M	F8-6989
1K0199555L	F8-7960
1K0199555N	F8-7961
1K0199555Q	F8-7962
1K0199555T	F8-8152
1K0199855BA	F8-7965
1K0199855BB	F8-7966
1K0199867Q	F8-7981
1K0199868Q	F8-7982
1K0407182	F8-5633
1K0407182A	F8-5633
1K0407183A	F8-6736
1K0407183E	F8-6736
1K0407183L	F8-6736
1K0407183M	F8-7856
1K0407183P	F8-7856
1K0412303B	F8-7131
1K0412303E	F8-7809
1K0412303F	F8-7697
1K0412303G	F8-7703
1K0412303H	F8-7834
1K0412331B	F8-6284
1K0412331B	F8-6570
1K0412331C	F8-6284
1K0412331C	F8-6570
1K0505171C	F8-7902
1K0505203A	F8-7907
1K0505279A	F8-7908
1K0505541D	F8-6463
1K0505553 A	F8-7909
1K0511327AP	F8-7930
1K0511327AR	F8-7923
1K0511353F	F8-7897
1K0513353J	F8-6350
1K0513353R	F8-7603
1K0513425A	F8-7640
1S0412303	F8-7891
1S0412303A	F8-7892
1S0511351B	F8-7893
1S0513425A	F8-7486

SKODA	
1T0511359	F8-7836
357407182	G9-648
357407182F	F8-7978
357412249	F8-3039
357412249A	F8-3039
357412303F	AK-735065
357412303F	F8-5993
357412341A	F8-5580
357413175A	AK-735039
357413175A	F8-5683
3B0512131H	F8-6001
3B0513353	F8-6351
3B7199379A	F8-6949
3B7412377	F8-7471
3B7412377A	F8-7471
3C0199555P	F8-7963
3C0511359	F8-7140
3C0511359B	F8-7714
3C0513353	F8-7603
3C0513353C	F8-7603
3C0513353D	F8-7603
3C0513425	F8-6044
4B0399151M	F8-7971
4B0407515	F8-5542
4B0501521E	F8-6431
4B0501522E	F8-6430
4B0512131B	F8-6003
4B0512137B	F8-7802
4D0407182G	F8-4045
4D0407183D	G9-615
4D0407183M	G9-615
4D0407183N	G9-615
4D0407183P	G9-615
4D0407183Q	G9-615
4D0411327G	F8-5063
4D0411327H	F8-5064
4D0412137B	F8-7687
4D0412137C	F8-7687
5C0407183A	F8-7856
6N0412249B	F8-6281
6N0412249B	F8-6569
6N0412249C	F8-6281
6N0412249C	F8-6284
6N0412249C	F8-6569
6N0412249D	F8-6281
6N0412249D	F8-6284
6N0412249D	F8-6569
6N0412303A	F8-7830
6N0412331D	F8-5537
6N0412331D	F8-6281
6N0412331E	F8-5537
6N0412331E	F8-6281



SKODA		SKODA		SMART		SUZUKI	
6N0413175A	F8-7132	6U0512131C	F8-7674	4543250044	AK-735273	41710-57K00	F8-7624
6Q0 199 167 BC	F8-6532	6U0512333	F8-6345	4543260031	AK-735273	4171060B00	F8-5950
6Q0 199 167 CA	F8-6533	6U0512333	F8-7098	6401500360	F5-1121	41710-60B00S1	F8-5950
6Q0199167BM	F8-5551	6U0512333S	F8-6345	6401500560	F5-1121	417741-58J00	F8-6266
6Q0199167BN	F8-6752	6U0512335	F8-6345	6401500760	F5-1121	41810-60A01	F8-5951
6Q0199167BQ	F8-5535	6U0512335	F8-7099	6651V004	F8-6552	4185065D00	AK-735281
6Q0199167CB	F8-5535	6U0512335S	F8-6345	6697V004	F8-6551	4193154G00	AK-735277
6Q0199167CC	F8-6945	6U6407359A	F8-5290	6805V001	AK-735269	4193154G00	AK-735278
6Q0199167CE	F8-6945	6U6407360A	F8-5291	6861C003	AK-735268	4193154G00	AK-735279
6Q0199167CL	F8-6752	6X0512131A	AK-735409	6862V004	AK-735268	4193154G00	AK-735280
6Q0199167CS	F8-6945	6X0512131A	F8-6002	6862V004	AK-735271	4193165J00	AK-735282
6Q0199167DH	F8-7952	7296377	F8-5291	7001V004000000	F8-6730	4211165J00	AK-735282
6Q0199167DK	F8-6945	7296379	F8-5290	7001V006000000	F8-6730	4211170B11	AK-735274
6Q0199167DL	F8-6752	8D0199339E	F8-6758	7001V007000000	F8-6730	4225150A00	AK-735275
6Q0199555AB	F8-8173	8D0199379K	F8-5567	9975V003	AK-735271	4225154G10	AK-735277
6Q0199555AD	F8-8164	8D0199382L	F8-5538	9975V003	F8-7591	4225154G20	AK-735278
6Q0199555AE	F8-8173	8D0399151M	F8-5576	9975V003000000	F8-7591	4225163G00	AK-735279
6Q0199555AR	F8-7951	8D0412131F	F8-5994	A4503300051	F8-3039	4225163G00	AK-735280
6Q0199555AS	F8-8164	8D0419831K	LM-10021S	A4503300051	F8-8215	4225175F90	AK-735276
6Q0199555AT	F8-8173	8Z0411314B	F8-7914	A4513200029	F8-6551	4225175F90	AK-735283
6Q0199851AB	F8-5534	8Z0412331	F8-5537	A4513220028	F8-6514	4243170B42	F8-8125
6Q0199851AJ	F8-7955	8Z0412331	F8-6281	A4513220028	F8-8215	42431-70B42	F8-8125
6Q0199851AK	F8-7949	<b>SMART</b>		A4513230292	AK-735270	42451-76G00	F8-7857
6Q0199851AL	F8-7954	0006215V001	F8-3039	A4513230392	AK-735270	42451-76G00	F8-7857S
6Q0199851AP	F8-7956	0006651V004	F8-6552	Q0007001V004000	F8-6730	45201-79J00	F8-6449
6Q0199851AQ	F8-7950	0006697V004	F8-6551	Q0007001V006000	F8-6730	45202-79J00	F8-6449
6Q0199851M	F8-5533	0006862V004	AK-735271	Q0007001V007000	F8-6730	45261-65D01	F8-8222
6Q0199851S	F8-5532	0006862V0040000	AK-735271	Q0008236V003000	F8-6514	45261-79J00	F8-6448
6Q0407182A	F8-7873	0007001V0040000	F8-6730	Q0008236V004000	F8-6514	45262-65D01	F8-8223
6Q0411314F	F8-6694	0007001V0060000	F8-6730	Q0014141V001000	F8-6730	4553070C00	F8-5289
6Q0411314J	F8-6462	0007001V0070000	F8-6730	Q0014141V002000	F8-6730	4554060B02	F8-5288
6Q0411314L	F8-6462	0008236V003	F8-6514	<b>SUBARU</b>		<b>TALBOT</b>	
6Q0411314N	F8-6460	0008236V0030000	F8-6514	2020AG011	F8-7987	329373	MK-850850
6Q0411314P	F8-6462	0008236V004	F8-6514	20254-AE050	F8-8124	4066.20	LM-10004S
6Q0411314R	F8-6460	0008236V0040000	F8-6514	20321AA101	AK-735141	7701348568	MK-850850
6Q0412301	F8-7675	0009975V003	AK-735271	20321AA201	AK-735441	7910030073	LM-10004S
6Q0412301A	F8-7676	0009975V003	F8-7591	20322AA000	AK-735141	<b>TOYOTA</b>	
6Q0501541E	F8-7928	0009975V0030000	AK-735271	20322AA000	AK-735441	13407-0N010	F8-7867
6Q0512131B	AK-735266	0009975V0030000	F8-7591	20371AA041	AK-735144	13408-0R011	F8-7868
6Q0512131B	F8-6723	0014141V0010000	F8-6730	20371FC000	AK-735143	13408-0R030	F8-7868
6Q0512131C	F8-7658	0014141V0020000	F8-6730	20371FE110	AK-735142	13470-15120	F8-6389
6R0199555	F8-7957	03077V008000	F8-6426	20372AA001	AK-735142	13470-22021	F8-6388
6R0412249	F8-3039	05811V005000	F8-6427	20372AA001	AK-735143	2706000L20	F5-1080
6R0412249	F8-6280	05811V006000	F8-6427	20372AA031	AK-735144	2706030080	F5-1084
6R0501541A	F8-5340	14141V001000000	F8-6730	42451-76G00	F8-7857	27415-0L010	F5-1115
6R0513353B	F8-5380	14141V002000000	F8-6730	42451-76G00	F8-7857S	274150L020	F5-1047
6U0 407 182	G9-678	4503300051	F8-3039	<b>SUZUKI</b>		27415-0L020	F5-1101
6U0407182C	F8-6808	4513200029	F8-6551	3177168D00	F5-1039	274150L030	F5-1080
6U0411315	F8-6695	4513220028	F8-6514	31771-68D00	F5-1020	27415-0L030	F5-1115
6U0412355	F8-5550	4513230292	AK-735270	3177168D01	F5-1039	27415-0L040	F5-1101
6U0413175	AK-735065	4513230392	AK-735270	31771-68D01	F5-1020	27415-0W010	F5-1074
6U0512131A	F8-7674	4543230244	AK-735272	31771-85E00	F5-1045	27415-0W040	F5-1073



### TOYOTA

27415-0W041	F5-1073
27415-0W042	F5-1073
27415-0W060	F5-1074
27415-0W061	F5-1074
27415-0W062	F5-1074
27415-0W063	F5-1074
27415-0W130	F5-1074
27415-26010	F5-1152
27415-27011	F5-1030
2741530010	F5-1084
27415-30010	F5-1152
27415-30011	F5-1152
2741530020	F5-1080
27415-30020	F5-1115
27415-33020	F5-1133
27415-33060	F5-1145
4806105010	F8-8102
48061-05010	F8-8102
48061-60030	F8-8055
48061-60040	F8-8055
48068-0H010	F8-6587
48069-06080	F8-8048
48069-0H010	F8-6587
48069-59055	F8-8229
48071-12080	F8-7361
48071-12140	F8-7361
48072-12080	F8-7362
48072-12140	F8-7362
4815702060	AK-735297
4815702060	AK-735301
481570D010	AK-735287
481570D050	AK-735289
48157-0D050	AK-735289
481570H010	AK-735285
4815712080	AK-735293
48157-12080	AK-735293
4815732050	AK-735299
4815742010	AK-735439
4815742020	AK-735440
4815742030	AK-735284
4815747010	AK-735291
48157-47010	AK-735291
4815752030	AK-735289
48157-52030	AK-735289
4825705010	AK-735302
4825732090	AK-735292
48257-32090	AK-735292
4830417010	AK-735303
4833102050	AK-735301
48331-02050	F8-7677
483310F010	AK-735297
483310H010	AK-735285

### TOYOTA

4833112130	AK-735304
4833112200	AK-735293
4833112200	AK-735295
48331-12200	AK-735293
48331-12200	AK-735295
4833112210	AK-735296
4833112220	AK-735284
4833142020	AK-735439
4833142050	AK-735440
4833144030	AK-735299
4833147010	AK-735291
48331-47010	AK-735291
4833152010	AK-735287
4833152080	AK-735289
48331-52080	AK-735289
48341-02040	F8-7678
4834105030	AK-735302
483410F010	AK-735298
4834128100	AK-735300
4834147010	AK-735292
48341-47010	AK-735292
48603-06031	F8-7366
48603-08010	F8-7366
48603-33020	F8-7366
48603-33021	F8-7366
48609-01050	F8-7472
48609-02120	F8-7472
48609-06061	F8-7367
48609-06081	F8-7367
48609-08010	F8-7367
4860912210	F8-6369
4860912211	F8-6369
4860912231	F8-6369
4860912270	F8-6369
4860912330	F8-6369
48609-20471	F8-7472
48609-33110	F8-7367
48609-33120	F8-7367
48609-33121	F8-7367
48609-42010	F8-7473
48609-42011	F8-7473
48609-42012	F8-7473
48609-44020	F8-7360
48609-52021	F8-7474
48619-0D010	F8-6266
48619-0H010	F8-6266
48619-0H010	F8-7171
4861952040	F8-6266
48619-52040	F8-6266
4863226010	F8-8110
48632-26010	F8-8110
48632-35020	F8-8046

### TOYOTA

48632-60010	F8-8054
4863526010	F8-8111
48635-26010	F8-8111
48654-0H010	F8-6587
48654-12010	F8-8043
48654-12050	F8-8042
48654-12070	F8-8042
48654-14010	F8-8043
4865420170	F8-5286
48654-35010	F8-8045
48654-60010	F8-8052
48655-06030	F8-8041
48655-07010	F8-5287
48655-07020	F8-8041
48655-12050	F8-8044
48655-12120	F8-8065
48655-12170	F8-8047
4865520140	F8-8102
48655-20140	F8-8102
48655-33010	F8-5287
48655-60010	F8-8053
48702-60040	F8-8135
48702-60090	F8-8051
48702-60100	F8-8050
48702-60110	F8-8049
4872503010	F8-8103
48725-03010	F8-8103
487500D050	AK-735290
487500H010	AK-735286
4875052010	AK-735288
48815-30060	F8-8104
48815-33011	F8-8061
48815-33040	F8-8062
48815-33090	F8-8056
48815-35100	F8-8064
48818-06100	F8-8063
48818-20280	F8-8000
48818-21030	F8-8057
48818-33011	F8-8060

### VAUXHALL

0352300	G9-593
0352301	G9-590
0352327	F8-5112
0352341	F8-4098
0352358	F8-5110
0352458	F8-5108
1204366	F5-1049
1204517	F5-1045
13107328	F8-6733
13115706	F8-6944
13117280	AK-735251
13125208	F8-7794

### VAUXHALL

13125209	F8-7793
13125635	F8-6978
13125637	F8-6980
13138151	F8-5262
13159994	F8-6981
13159995	F8-6982
13159996	F8-6983
13159997	F8-6984
13159998	F8-6985
13167940	F8-6729
13178147	F8-7329
13178147	F8-7330
13186959	F8-7327
13186959	F8-7328
13186959	F8-7328S
13186960	F8-7327
13186960	F8-7328
13186960	F8-7328S
13188763	F8-7329
13188763	F8-7330
13189414	AK-735252
13189414	F8-7662
13197623	F8-7661
13243574	F8-7811
13251764	F8-7621
13257624	F8-7810
13270705	F8-7172
13270705	F8-7328
13270705	F8-7328S
13270705	F8-7330
13276432	F8-7615
13315196	F8-7615
13315197	F8-7889
1603180	MK-822920
22151076	AK-735254
22166978	AK-735254
22173720	AK-735254
24402155	F8-7328
24402155	F8-7328S
24416545	F8-6753
24416554	F8-6203
24417107	F7-2059
24422658	F8-7850
24427298	F8-6836
24430103	F8-5262
24435884	F8-7329
24435884	F8-7330
24459755	F8-6979
24459781	F8-6657
24459797	F8-6977
24459803	F8-6975
24469643	F8-7373



VAUXHALL		VAUXHALL		VAUXHALL		VAUXHALL	
26059295	LM-10041S	436503	F8-7615	90268463	G9-594	90445565	F8-5108
344 519	F8-5450	436504	F8-7889	90268464	F8-5501	90445571	F8-5109
344 523	F8-5448	4705518	AK-735247	90268464	F8-5501S	90447156	F8-5337
344349	AK-735251	4708288	AK-735437	90278345	F8-5372	90447528	F8-6826
344416	AK-735251	4708288	F8-7326	90278346	F8-5468	90447867	F8-5332
344416	AK-735252	5344026	F8-7810	90278624	F8-5331	90447946	F8-5228
344417	AK-735038	55575960	F8-7872	90279193	F8-4098	90468554	F8-5448
344419	AK-735254	55700767	AK-735251	90279437	F8-4097	90468618	F8-6517
344420	AK-735254	55700767	AK-735252	90288082	G9-594	90468636	F8-4090
344424	F8-7698	55700767	F8-7663	90288206	F8-4100	90468638	F8-5110
344426	AK-735253	55701796	F8-7422	90288206	F8-6324	90468644	AK-735038
344427	AK-735249	55703313	F8-7421	90288207	F8-4097	90470670	F8-7053
344435	AK-735251	55703317	F8-7423	90288232	G9-593	90473837	F8-8166
344435	AK-735252	55703318	F8-7424	90289421	F8-5501	90473846	F8-5372
344435	AK-735253	684285	F8-5467	90289421	F8-5501S	90473848	F8-6959
344503	F8-7172	684646	F8-5418	90289667	F7-2059	90473852	F8-5444
344503	F8-7330	90 445 208	F8-5450	90289721	F8-5440	90495046	F8-5334
344507	F8-5434	90023735	F8-6765	90305431	F8-4102	90495169	F8-5371
344522	F8-5434	90090811	LM-10045S	90334546	G9-592	90495513	F8-6739
344536	F8-7329	90090811	M-822300	90335966	G9-591	90495514	F8-6740
344536	F8-7330	90090811	MK-822300	90343305	F8-5338	90496186	F8-5370
344537	F8-7329	90090811	MK-822300	90343676	F8-4106	90496681	F8-5335
344537	F8-7330	90092805	F8-6659	90344690	F8-5444	90496686	F8-5723
344543	F8-7327	90106190	F8-5366	90345164	F8-5436	90496700	F8-5201
344543	F8-7328	90112571	F8-7584	90345195	LM-10045S	90496706	F8-6660
344543	F8-7328S	90121275	F8-6324	90345195	M-822300	90496721	F8-5336
344544	F8-7327	90125491	M-822900	90345195	MK-822300	90496738	F8-7850
344544	F8-7328	90125491	MK-822920	90345195	MK-822300	90496942	F8-5367
344544	F8-7328S	90125889	F8-5710	90345330	F8-5304	90497919	F8-7850
344565	F8-7328	90129855	F8-8145	90345330	F8-5304S	90497969	F8-8183
344565	F8-7328S	90135359	F8-5101	90372425	F8-5418	90498689	F8-6734
344625	F8-7172	90154756	F8-3059	90372559	F8-4102	90498738	F8-4090
344625	F8-7328	90170152	F8-5112	90372699	F8-5391	90498740	F8-5130
344625	F8-7328S	90170695	F8-3027	90373263	F8-5968	90512778	LM-10030S
344625	F8-7330	90184756	F8-3059	90373263	G9-593	90531583	F8-7869
344645	AK-735254	90189050	F8-3060	90373264	F8-5969	90538063	F8-8166
344665	F8-7172	90189509	F8-8145	90373264	G9-594	90538326	F8-3025
344665	F8-7328	90193117	G9-591	90373778	G9-593	90538326	F8-5304S
344665	F8-7328S	90193760	F8-4092	90373854	F8-4097	90538576	F8-8071
344665	F8-7330	90217845	F8-5552	90374844	F8-3025	90538582	F8-8142
344956	AK-735252	90222781	F8-6766	90374844	F8-5304S	90538936	F8-5463
344963	F8-7422	90223323	F8-6883	90421747	M-822900	90542853	M-822900
344969	F8-7811	90223456	F8-4099	90421747	MK-822920	90575186	F8-6835
350127	F8-5228	90235040	G9-592	90425479	F8-3026	90575190	F8-6217
352334	G9-591	90235055	F8-6826	90425479	F8-5501S	90575456	F8-5365
352335	G9-592	90235056	F8-6826	90425689	F8-6765	90575457	F8-6755
352348	G9-594	90236985	F8-3026	90445097	G9-590	90575459	F8-8155
352864	F8-6729	90236985	F8-5501S	90445098	F8-5128	90575779	F8-6836
374050	MK-822920	90250709	F8-6656	90445100	F8-6037	90576047	F8-5368
423313	F8-4099	90250986	F8-4101	90445101	F8-6038	90576048	F8-6494
434030	AK-735255	90251358	F8-4100	90445298	F8-5437	90576775	F8-5108
436448	F8-7615	90251358	F8-6324	90445304	F8-5441	90578558	F8-6765



VAUXHALL		VAUXHALL		VOLVO		VOLVO	
9109403	LM-10002S	97361525	F8-7089	30639368	F8-6718	31201027	F8-7607
9110612	F8-6688	98022837	F8-7872	30639948	F8-6268	31201027	F8-7608
9112592	F8-6684	98039173	F8-7872	30639948	F8-7156	31251073	F5-1036
91160038	F8-6478	<b>VOLVO</b>		30645371	AK-735312	31251074	F5-1025
91165309	F8-6196	012737789	F8-5076	30645447	F8-6993	31262065	F8-6198
91165437	F8-6691	013296553	F8-5140	30647413	F8-6357	31262470	F8-6268
91165701	F8-6661	013595996	F8-5106	30666175	F8-6992	31262470	F8-7156
91166249	F8-6690	074105251N	F8-5202	30666243	AK-735306	31277241	F8-8140
91166683	F8-6692	1205825	F8-5129	30666271	F8-6198	31277826	F8-7607
91166684	F8-6693	1205991	F8-5571	30666331	F8-6638	31277826	F8-7608
91167992	F8-7733	1229165	F8-5718	30666530	F8-6268	31285489	F5-1134
91167993	F8-7736	1229297	F8-5106	30666530	F8-7156	31329091	AK-735305
9120708	LM-10002S	1229301	F8-6769	30666821	F8-6638	31329092	AK-735305
9156605	F8-5109	1229628	F8-5718	30666842	AK-735305	31329093	AK-735305
9156933	F8-8170	1229714	F8-5762	30666842	F8-7838	31360451	AK-735305
9160391	F8-6687	1229715	F8-5736	30666850	AK-735308	31387282	F8-8069
9160394	F8-6673	1272779	F8-6769	30667067	F5-1072	31406337	F8-7877
9160395	F8-6674	1272789	F8-6769	30667610	F5-1075	31406350	F8-7878
9160402	F8-6684	1273184	F8-6769	30667687	F5-1046	3266405	F8-3036
9161560	LM-10032S	1273622	F8-5691	30678433	F8-6357	32664054	F8-3036
9191165	F8-4090	1273711	F8-5076	30680339	F8-8140	3345796	LM-10061S
9191181	F8-7172	1273747	F8-5984	30680750	F8-8148	3350052	F8-7694
9191181	F8-7330	1273747	F8-6267	30681546	F8-6210	3410738	AK-735080
9191494	F8-6974	1273778	F8-5076	30681546	F8-7156	34110700	F8-3033
9199576	F8-5263	12737789	F8-5076	30683637	F8-7947	3466003	F8-7028
92085608	F8-6835	1273849	F8-5899	30714349	F8-6357	3507924	F8-6759
9209466	F8-7857	1328900	F8-6549	30714395	F8-6357	3516122	F8-7694
9209466	F8-7857S	1329428	F8-7354	30714968	F8-6014	3516151	F8-5929
9223022	F8-6734	1329655	F8-5140	30714968	F8-6384	3516327	AK-735310
9227878	F8-7794	13296553	F8-5140	30723051	AK-735306	3516327	F8-5921
9227879	F8-7793	1330218	F8-6769	30736424	AK-735305	3516496	F8-7696
9227882	F8-8158	1330220	F8-6769	30741397	F8-6992	3516496	F8-7696S
9227883	F8-8161	1330427	F8-5735	30741958	F8-6992	3530050	F8-7694
9231099	AK-735251	1330831	F8-6549	30748811	F8-8156	3530051	F8-7694
9231099	AK-735252	1330973	F8-5736	30760405	AK-735305	3530052	F8-7694
9231099	F8-7663	1359599	F8-5106	30776354	F8-6993	3530202	F8-7695
9266152	F8-6881	13595996	F8-5106	30778647	F8-8140	3530202	F8-7695S
9266153	F8-7879	1359808	F8-6769	30778648	F8-8140	3530341	F8-5984
93171448	F8-6447	1378657	F8-7355	30782701	F5-1087	3530341	F8-6267
93182514	F5-1123	1387188	F8-5983	30818103	F8-6772	3546189	F8-5915
93191295	F8-7172	1387188	F8-5984	30818465	F8-5933	3546189	F8-6385
93191295	F8-7328	1387188S1	F8-5984	30818467	F8-5249	3546238	F8-5570
93191295	F8-7328S	271631	F8-6548	30851257	F8-6696	3546238	F8-6384
93191295	F8-7330	272483	MK-810160	30871221	F8-6696	3546238	F8-6385
93193111	AK-735437	274165	MK-810160	30871230	F8-6994	3546705	AK-735311
93193111	F8-7326	274337	MK-810160	30884198	AK-735123	3546705	F8-5922
93230328	F8-8145	30 711 931	MK-810160	30884200	AK-735123	675807	F8-5735
93853290	F8-6691	30611144	F8-6994	30889584	F8-6337	6800251	F8-6548
93853920	F8-7737	30616824	F8-6337	31 277 755	F8-7878	6819057	F8-5254
93856473	F8-6661	30616825-3	F8-5504	31200599	F8-5915	6819287	F8-5245
93860700	F8-7736	30620785	F8-6469	31200599	F8-6385	6819537	F8-5242
97251975	F8-7089	30620972	F8-6772	31201003	F8-6776	6842253	F8-8148



VOLVO		VOLVO		VW		VW	
8624755	F8-6992	9459747	F5-1032	03G 105 243B	F8-6573	171419831C	LM-10024S
8624757	F8-8156	9461524	F8-5929	03G105243	F8-6396	171419831C	LM-10050S
8627933	F8-5202K1	9461626	F8-6167	03G105243C	F8-6396	171419832	LM-10064S
8630604	F8-6167	9461728	F8-5570	045105243	F8-8038	171419832A	F8-4074
8631698	F8-8190	9461728	F8-6384	045105243C	F8-8038	171419832A	LM-10064S
8634457	F8-6014	9461728	F8-6385	045903119A	F5-1085	171419832B	F8-4074
8634457	F8-6384	9465971	F8-6166	049129761	F8-3046	171419832C	F8-4074
8641982	F5-1014	9472909	F5-1087	050129761A	F8-3048	171419832C	LM-10064S
8646295	AK-735309	9485152	F8-8156	050129761B	F8-3048	171498203	M-830220
8646713	F8-5570	9485400	F8-8148	050129761C	F8-3047	171498203	MK-830220
8646713	F8-6384	9492802	F8-6992	050129761E	F8-3045	175412329A	F8-1002
8646713	F8-6385	9492872	F8-8156	050129761F	F8-3048	175422831	LM-10003S
8658644	F5-1031			050129761H	F8-3048	175422831	LM-10006S
8659000	F8-8148		<b>VW</b>	051129761	F8-3047	176199402	F8-1006
8666126	F5-1025	021156017A	F8-3036	052129765A	F8-4013	176412303A	F8-4063
8666579	F5-1072	021903119H	F5-1031	059903119L	F5-1140	176412329	F8-1009B
8671633	F8-6882	021903119K	F5-1031	068121275	F8-4011	176412329A	F8-1009B
8672087	AK-735130	026129761A	F8-3044	068251393B	F8-4023	191199233	F8-5554
8672453	F8-6882	026129761E	F8-3044	06A105243E	F8-5650	191199262A	F8-1003
8672488	AK-735313	027129761	F8-3045	06B903119B	F5-1044	191199262C	F8-1025
8683293	F8-6992	027129761A	F8-3045	06B903119D	F5-1044	191199273C	F8-3049
9140067	F8-5919	027129761F	F8-3045	06H105243F	F8-7880	191199279C	F8-1004
9140068	AK-735130	028 105 243AC	F8-6398	06H105243G	F8-7880	191199279E	F8-1005
9140068	AK-735312	028105243Q	F8-5654	06H105243K	F8-7880	191199279F	F8-1005
9140129	F8-5920	028105243T	F8-5649	070199231	F8-4014	191199292B	F8-5401
9140177	AK-735311	028903119AJ	F5-1024	070199231A	F8-4015	191199381A	F8-6922
9141042	F8-8148	028903119AN	F5-1008	070903201C	F5-1103	191199402	F8-1006
9157115	AK-735307	028903119AP	F5-1010	070903201E	F5-1103	191199402A	F8-1006
9157115	F8-7680	028903119AQ	F5-1007	074105251AC	F8-5202K1	191199402B	F8-1006
9157264	F8-6769	028903119S	F5-1010	074105251N	F8-5202	191199402C	F8-1006
9157459	F8-6769	028903119T	F5-1008	074105251N	F8-5202K1	191253147C	F8-4027
9157745	F8-6198	030129765	F8-7744	07K903119C	F5-1076	191407181A	F8-1007
9161149	F8-6882	030129765C	F8-7744	1011898	F8-5995	191407181A	F8-1007S
9163918	F8-5202K1	033251393	F8-4023	1044571	G9-664	191407181A	F8-1008
9169311	F8-6769	037129761	F8-7743	113501149	F8-4080	191407181B	F8-1007
9173203	F8-5570	038 105 243	F8-7864	171199214K	F8-1001	191407181B	F8-1007S
9173203	F8-6384	038105243	F8-6392	171199241G	F8-1001	191407181B	F8-1008
9173203	F8-6385	038105243F	F8-6391	171253147	F8-4027	191407181D	F8-1008
9173618	F8-6166	038105243K	F8-6392	171253147A	F8-4027	191407181E	F8-1008
9173954	F8-5245	038105243L	F8-6572	171407181A	G9-540	191407182	G9-648
9180620	F8-5202K1	038105243M	F8-6572	171407182D	G9-541	191407190A	F8-6699
9181013	F8-7695	038903119	F5-1009	171411313	F8-5147	191407285F	F8-7722
9181013	F8-7695S	038903119L	F5-1013	171411314	F8-5146	191411314	F8-3042
9181027	F8-7696	038903119L	F5-1016	171411314A	F8-5146	191411329	F8-4060
9181027	F8-7696S	038903119M	F5-1006	171412135	F8-5694	191412135	AK-733023
9186364	F8-8156	038903119P	F5-1002	171412303C	F8-5755	191412135	F8-4064
9191537	F8-5245	038903119Q	F5-1011	171412329A	F8-1002	191412249	F8-3036
9200154	F8-8094	038903119T	F5-1004	171412331A	F8-1002	191412303	F8-4063
9404328	F5-1015	03C903119A	F5-1064	171419831	LM-10024S	191412303A	F8-4063
9434263	F8-5027	03C903119C	F5-1064	171419831	LM-10050S	191412303C	F8-4063
9434288	F8-5027	03C903119D	F5-1064	171419831B	LM-10024S	191412329	F8-1009B
9443882	F8-6166	03C903119F	F5-1064	171419831B	LM-10050S	191412331	F8-1009B
		03D903119A	F5-1000				



VW		VW		VW		VW	
191412341	F8-5360	1H0422831B	LM-10003S	1J0501541C	F8-5340	1K0199867Q	F8-7981
191419831	F8-4069	1H0422831B	LM-10006S	1J0501541D	F8-6076	1K0199868Q	F8-7982
191419831	LM-10024S	1H0422884	F8-5394	1J0501541DS	F8-6077	1K0407182	F8-5633
191419831	LM-10050S	1H0501541	F8-4008	1J0501541DS1	F8-6077	1K0407182A	F8-5633
191419883	F8-5145	1H0501541	F8-4008S	1J0505145B	F8-7046	1K0407183A	F8-6736
191422831	F8-4075	1H0501541A	F8-4008	1J0512131	F8-6012	1K0407183E	F8-6736
191422831	LM-10003S	1H0501541A	F8-4008S	1J0512131B	AK-735095	1K0407183G	F8-7991
191422831	LM-10006S	1H0512149	F8-5393	1J0512131B	F8-6013	1K0407183L	F8-6736
191498203C	M-830220	1H9501541	F8-5392	1J0512131C	F8-6007	1K0407183M	F8-7856
191498203C	MK-830220	1H9501541	F8-5392S	1J0512149B	F8-5381	1K0407183P	F8-7856
191501541	F8-1010	1H9512131	AK-735026	1J0513353A	F8-5380	1K0412303B	AK-735175
191501541	F8-1010S	1J0 411 336 B	F8-6579	1J0513353B	F8-5380	1K0412303B	F8-7131
191512113	F8-5362	1J0 411 336 C	F8-6579	1J0513353C	F8-5380	1K0412303E	F8-7809
191512131	F8-5594	1J0 411 336 D	F8-6579	1J0513353D	F8-6040	1K0412303F	AK-735186
191512131B	F8-5594	1J0199262BE	F8-5390	1J0513353G	F8-5380	1K0412303F	F8-7697
191512333	F8-5403	1J0199262BF	F8-5404	1J0513425	AK-735409	1K0412303G	F8-7703
191512333	F8-6382	1J0199262BK	F8-5388	1J0513425	F8-6044	1K0412303H	F8-7834
191512333S	F8-6382	1J0199262P	F8-6960	1J0513425A	AK-735095	1K0412303M	F8-7174
191512335	F8-5402	1J0199429	F8-5907	1J0513425A	F8-6045	1K0412303P	F8-7832
191512335	F8-6382	1J0199555AH	F8-5387	1JD422831B	LM-10020S	1K0412331B	F8-6284
191512335S	F8-6382	1J0199555AJ	F8-5386	1JD422832	LM-10020S	1K0412331B	F8-6570
191513425	F8-5747	1J0199555AK	F8-5385	1K0 199 262 AT	F8-6528	1K0412331C	F8-6284
1G0199292	F8-5401	1J0199555AL	F8-5384	1K0 511 353 M	F8-7576	1K0412331C	F8-6570
1H0199233A	F8-5672	1J0199555BD	F8-8198	1K0 511 353 P	F8-7600	1K0505171C	F8-7902
1H0199262A	F8-1011	1J0199851AA	F8-5383	1K0199231G	F8-6425	1K0505203A	F8-7907
1H0199262B	F8-4016	1J0407181	G9-649	1K0199231J	F8-6425	1K0505279A	F8-7908
1H0199262D	F8-5400	1J0411314AC	F8-7927	1K0199231P	F8-6425	1K0505541B	F8-6463
1H0199262E	F8-4017	1J0411314C	F8-5221	1K0199232G	F8-6424	1K0505541C	F8-6463
1H0199262F	F8-1011	1J0411314G	F8-5220	1K0199232J	F8-6424	1K0505541D	F8-6463
1H0199262G	F8-4016	1J0411314P	F8-7901	1K0199232P	F8-6424	1K0505553A	F8-7909
1H0199262H	F8-4016	1J0411314R	F8-5221	1K0199262AB	F8-6989	1K0511327AP	F8-7930
1H0199262K	F8-5400	1J0411314S	F8-5215	1K0199262AC	F8-6988	1K0511327AR	F8-7923
1H0199262L	F8-5399	1J0411314T	F8-5220	1K0199262AJ	F8-6531	1K0511353F	F8-7897
1H0199402	F8-1015	1J0411327	F8-5382	1K0199262AK	F8-6991	1K0511353M	AK-735172
1H0199609B	F8-3053	1J0411327A	F8-7936	1K0199262AL	F8-6988	1K0511353N	F8-7601
1H0199609D	F8-6717	1J0412131	F8-6012	1K0199262AM	F8-6989	1K0511353R	F8-7176
1H0199609E	F8-5398	1J0412131B	F8-6013	1K0199262AR	F8-7008	1K0513353G	F8-6348
1H0199609F	F8-5397	1J0412131C	F8-6007	1K0199262AS	F8-7958	1K0513353H	F8-6349
1H0199609G	F8-5346	1J0412249	F8-3039	1K0199262CG	F8-7959	1K0513353J	F8-6350
1H0199609J	F8-5396	1J0412249	F8-6280	1K0199262J	F8-6531	1K0513353R	F8-7603
1H0199609K	F8-6717	1J0412303	F8-6041	1K0199262K	F8-6991	1K0513425A	AK-735172
1H0253144	F8-4025	1J0412319C	F8-7133	1K0199262L	F8-6988	1K0513425A	F8-7640
1H0253144A	F8-4025	1J0412331	F8-4067	1K0199262M	F8-6989	1K0513425D	F8-7627
1H0253144C	F8-4025	1J0412331	F8-6280	1K0199262P	F8-6990	1S0412303	F8-7891
1H0411314	F8-5395	1J0412331B	F8-4067	1K0199262Q	F8-7008	1S0412303A	F8-7892
1H0412303A	F8-4063	1J0412331B	F8-6280	1K0199262T	F8-6531	1S0511351B	F8-7893
1H0412303B	AK-735039	1J0412331C	F8-4067	1K0199555L	F8-7960	1S0513425A	F8-7486
1H0412303B	F8-5996	1J0412331C	F8-6280	1K0199555N	F8-7961	1T0511359	F8-7836
1H0422831	LM-10003S	1J0412341	F8-5580	1K0199555Q	F8-7962	211501149	F8-4081
1H0422831	LM-10006S	1J0422831	LM-10020S	1K0199555T	F8-8152	251199201G	F8-3054
1H0422831A	LM-10029S	1J0422831B	LM-10020S	1K0199855BA	F8-7965	251407077	F8-1012
1H0422831B	F8-4075	1J0501541B	F8-5340	1K0199855BB	F8-7966	251407077B	F8-1012



VW		VW		VW		VW	
251407175	F8-4033	2K0511413C	F8-7798	357512131	F8-7701	4A0018977	F8-5548
251407175A	F8-4033	2K0511413D	F8-7798	357512131B	F8-7701	4A0199351B	F8-5547
251407179	F8-4034	321498203A	MK-822920	357513425	AK-735040	4A0199352A	F8-5546
251407183	F8-4032	321501541	F8-1014	377412335A	F8-3036	4A0199379C	F8-5545
251407183B	F8-4032	321512131B	F8-5673	3A0199402	F8-3041	4A0253147	F8-4026
251411041C	F8-4053	321512131C	F8-5673	3A0501541	F8-1016	4A0253147A	F8-4026
251411045	F8-4054	321512131D	F8-5673	3B0399151	F8-7048	4A0399151C	F8-5544
251419831	LM-10031S	3266405	F8-3036	3B0512131H	F8-6001	4A0399415B	F8-5543
251419831A	F8-4071	333501541	F8-1016	3B0513353	F8-6351	4A0407181A	F8-1024
251419831A	LM-10031S	333513425	F8-5765	3B7199379A	F8-6949	4A0407183D	G9-617
251501131A	F8-4082	357199262A	F8-5377	3B7412377	F8-7471	4A0411327A	F8-3006
27129761	F8-3045	357199262D	F8-4018	3B7412377A	F8-7471	4A0412377A	F8-3009
281407077	F8-1013	357199279	F8-3040	3C0199231A	F8-6701	4A0412377B	F8-3009
281407091B	F8-5808	357199279B	F8-3040	3C0199231B	F8-6701	4A0412377C	F8-3009
281407179	F8-4035	357199381A	F8-5491	3C0199231D	F8-6701	4A0511247	F8-5342
281407180	F8-4036	357199381C	F8-5491	3C0199231E	F8-6701	4A0511247B	F8-5306
281411041	F8-4052	357199402	F8-1015	3C0199555P	F8-7963	4B0399151M	F8-7971
291411045	F8-5100	357199402A	F8-3041	3C0199555Q	F8-7964	4B0407515	F8-5542
291511171C	F8-5207	357199402B	F8-1015	3C0199855A	F8-7851	4B0501521D	F8-6431
291511181	F8-5206	357199402C	F8-3041	3C0199855J	F8-7851	4B0501521E	F8-6431
2D0 407 140	F8-6529	357199609	F8-6717	3C0412303A	AK-735184	4B0501522D	F8-6430
2D0 598 351	F8-6240	357407181	F8-1008	3C0412303A	F8-7131	4B0501522E	F8-6430
2D0199379A	F8-8147	357407182	G9-648	3C0511359	AK-735185	4B0512131B	F8-6003
2D0199379B	F8-8144	357407182F	F8-7978	3C0511359	F8-7140	4B0512131N	F8-6005
2D0399201	F8-8144	357411313	F8-5235	3C0511359B	AK-735187	4B0512137B	F8-7802
2D0407183	F8-6700	357411313A	F8-4057	3C0511359B	F8-7714	4D0407181F	F8-4044
2D0407183A	F8-6704	357411314	F8-5224	3C0513353	F8-7603	4D0407181H	F8-4044
2D0411041A	F8-5261	357411314A	F8-4058	3C0513353C	F8-7603	4D0407182E	F8-4045
2D0411041B	F8-5378	357412135	F8-4064	3C0513353D	F8-7603	4D0407182G	F8-4045
2D0412135	AK-735418	357412249	F8-3039	3C0513425	AK-735185	4D0407183D	G9-615
2D0412135	F8-7160	357412249A	F8-3039	3C0513425	AK-735187	4D0407183M	G9-615
2D0511171	F8-5019	357412303B	AK-733023	3C0513425	F8-6044	4D0407183N	G9-615
2D0511171B	F8-5788	357412303E	F8-4063	3C0513425B	F8-7845	4D0407183P	G9-615
2D0511181	F8-5979	357412303F	F8-5993	3D0 498 201	MK-810160	4D0407183Q	G9-615
2D0511413	F8-5752	357412329	F8-1009C	411513121	F8-6261	4D0407515	G9-616
2D0511413A	F8-5846	357412331A	F8-1034	431121273	F8-4009	4D0407515C	G9-616
2D0511413B	F8-5453	357412331A	F8-1034S	431399151D	F8-4028	4D0407516C	F8-5471
2E0407523	F8-7161	357412331AS	F8-1034S	431407183A	F8-1018	4D0411327E	F8-5063
2E0407523A	F8-7162	357412331AS1	F8-1034S	431407285B	MK-822920	4D0411327G	F8-5063
2E0411041E	F8-8105	357412341	F8-5360	431419831	F8-4070	4D0411327H	F8-5064
2E0411041F	F8-8106	357412341A	F8-5580	431498203A	MK-822920	4D0412137B	F8-7687
2E0411085	F8-8105	357413175A	AK-735039	431505172	F8-5344	4D0412137C	AK-735101
2E0411085	F8-8106	357413175A	F8-5683	431511247C	F8-1019	4D0412137C	F8-7687
2H0407077A	F8-7881	357422831	LM-10003S	443199379	F8-1020	4D0412377D	F8-3050
2H0407182A	F8-7882	357422831	LM-10006S	443199381C	F8-1020	4D0412377D	F8-7096
2H0407183A	F8-5303	357422831A	LM-10003S	443199381J	F8-6925	4D0412377D	F8-7097
2H0412303D	F8-7898	357422831A	LM-10006S	443199382	F8-1021	4D0412377DS	F8-7096
2H0412333A	F8-7883	357422831B	F8-4076	443399419	F8-3001	4D0412377DS	F8-7097
2K0511155	F8-7679	357422831B	LM-10029S	443407285A	MK-822920	4D0412377F	F8-3050
2K0511155A	F8-7679	357501541	F8-1016	443411327	F8-3005	4D0412377F	F8-7096
2K0511413A	F8-7798	357501541A	F8-1016	443498203C	MK-822920	4D0412377F	F8-7097
2K0511413B	F8-7798	357501541AS	F8-1016S	443512331	F8-3010	4D0419831A	F8-7148





VW		VW		VW		VW	
4D0419831A	LM-10093S	6Q0 199 167 DG	F8-6987	6X0411313	F8-6190	7H0501132A	F8-7911
4D0419831B	LM-10005S	6Q0 411 314 M	F8-6461	6X0411313A	F8-6191	7H5411313A	F8-7387
4D0419831D	LM-10005S	6Q0199167BM	F8-5551	6X0512131A	F8-6002	7H5411313A	F8-8216
4D0511523A	F8-5541	6Q0199167BN	F8-6752	701399201AE	F8-5531	7H5411313B	F8-7904
4D0511523C	F8-5541	6Q0199167BQ	F8-5535	701399201AG	F8-7047	7L0407077	F8-6705
4E0407182B	F8-7795	6Q0199167CB	F8-5535	701399661	F8-7041	7L0407182C	F8-6706
4E0407182C	F8-7795	6Q0199167CC	F8-6945	701407077	F8-4037	7L0407182D	F8-7875
4E0407183B	F8-8117	6Q0199167CE	F8-6945	701407077A	F8-4037	7L0407182E	F8-6706
51129761	F8-3047	6Q0199167CF	F8-6987	701407087	F7-2001	7L0407182F	F8-7875
535199262	F8-1025	6Q0199167CL	F8-6752	701407140B	F8-4038	7L0407182G	F8-7875
5C0407183A	F8-7856	6Q0199167CS	F8-6945	701407140C	F8-4038	7L0407183A	F8-6707
68121275	F8-4011	6Q0199167DH	F8-7952	701407183	F7-2002	7L0412137	AK-735188
6K0501541A	F8-7938	6Q0199167DK	F8-6945	701407183C	F8-4039	7L0412137	AK-735189
6K0512131A	F8-6006	6Q0199167DL	F8-6752	701407303	F8-4040	7L0412137	F8-7804
6K0512131B	F8-6008	6Q0199167J	F8-6986	701411041	F8-4055	7L0412303A	AK-735190
6N0 199 851 AG	F8-6501	6Q0199555AB	F8-8173	701411041D	F8-4056	7L0412303A	F8-7805
6N0199262G	F8-7948	6Q0199555AD	F8-8164	701419831	F8-4072	7L0412333A	F8-5301
6N0199262L	F8-5540	6Q0199555AE	F8-8173	701419831	LM-10015S	7L0422831A	LM-10100S
6N0199555AA	F8-6923	6Q0199555AR	F8-7951	701419831	LM-10017S	7L0498137	AK-735190
6N0199555G	F8-6923	6Q0199555AS	F8-8164	701501131	F8-4083	7L0498137	AK-735191
6N0199555H	F8-8189	6Q0199555AT	F8-8173	70199231	F8-4014	7L0498137	F8-7806
6N0407181	F8-5105	6Q0199851AB	F8-5534	7201848	F8-1034	7L0499035A	F8-8131
6N0407182	F8-5104	6Q0199851AJ	F8-7955	7201848S1	F8-1034S	7L0512131B	AK-735189
6N0411329	F8-4060	6Q0199851AK	F8-7949	7398680	F8-5051	7L0512131B	F8-7807
6N0412249B	F8-6281	6Q0199851AL	F8-7954	7403748	F8-5530	7L0512131C	AK-735191
6N0412249B	F8-6569	6Q0199851AP	F8-7956	74105193	F8-5202K1	7L0512131C	F8-7808
6N0412249C	F8-6281	6Q0199851AQ	F8-7950	74105251N	F8-5202	7L6412303	AK-735188
6N0412249C	F8-6284	6Q0199851M	F8-5533	74105251N	F8-5202K1	7M0199131BA	F8-7010
6N0412249C	F8-6569	6Q0199851S	F8-5532	7D0199132C	F8-7749	7M0399201AK	F8-8150
6N0412249D	F8-6281	6Q0407182A	F8-7873	7D0199132D	F8-7748	7M0399201BG	F8-8150
6N0412249D	F8-6284	6Q0411314E	F8-6460	7D0199132E	F8-7749	7M0399201BQ	F8-8150
6N0412249D	F8-6569	6Q0411314F	F8-6694	7D0407140	F8-4038	7M0407181A	G9-664
6N0412303A	F8-7830	6Q0411314J	F8-6462	7D0407140A	F8-4038	7M0411031	F8-5407
6N0412331	F8-5494	6Q0411314L	F8-6462	7D0407183	F8-4039	7M0412303B	F8-5995
6N0412331A	F8-5494	6Q0411314N	F8-6460	7D0419831	LM-10015S	7M0412331	F8-1034
6N0412331AS	F8-5523	6Q0411314P	F8-6462	7D0419831	LM-10017S	7M0413175A	F8-7688
6N0412331D	F8-5537	6Q0411314R	F8-6460	7D1411041	F8-6708	7M0422831B	F8-5051
6N0412331D	F8-6281	6Q0412301	F8-7675	7E0 412 331	F8-6540	7M0422831B	LM-10023S
6N0412331E	F8-5537	6Q0412301A	F8-7676	7E0412249	F8-7494	7M0501541	G9-665
6N0412331E	F8-6281	6Q0512131B	F8-6723	7E0412249	F8-7575	7M0505221B	F8-5530
6N0413175A	AK-735175	6Q0512131C	F8-7658	7E0412331	F8-7575	7M0505221C	F8-5530
6N0413175A	AK-735184	6Q0513353	F8-5380	7H0199256F	F8-7967	7M0511413A	F8-6702
6N0413175A	AK-735186	6Q0513425	F8-7338	7H0199848G	F8-7983	7M0511414B	F8-6703
6N0413175A	F8-7132	6QE513353	F8-5380	7H0199849BB	F8-7968	7M3399201H	F8-7049
6N0419831	F8-5061	6R0199555	F8-7957	7H0399151G	F8-7984	7M3399201K	F8-7032
6N0501541D	F8-5341	6R0412249	F8-3039	7H0407182	F8-7745	7M3422831	LM-10023S
6N0501541D	F8-5341S	6R0412249	F8-6280	7H0407182A	F8-5302	7N0511359	F8-7815
6N0501541E	F8-7938	6R0501541A	F8-5340	7H0407183	F8-5303	7N0511359A	F8-7816
6N0512131A	F8-6004	6R0513353B	F8-5380	7H0411313	G7-1001	7P0407077	F8-8091
6Q0 199 167 BC	F8-6532	6U0412355	F8-5550	7H0412249A	F8-7494	803121273	F8-4011
6Q0 199 167 CA	F8-6533	6U0512131A	F8-7674	7H0412249A	F8-7575	811199415A	F8-1031
6Q0 199 167 CP	F8-6987	6U0512131C	F8-7674	7H0501131A	F8-7910	811199419A	F8-5685



VW	
811199419B	F8-1032
811199419C	F8-1032
811399151A	F8-4030
811399151B	F8-4030
811407181	F8-1026
811407181A	F8-1026
811407181F	F8-1026
811411327A	F8-5081
811412131A	F8-4062
811412131B	F8-4062
811412135A	F8-4065
811412135B	F8-4065
811412323	F8-1027
811412323C	F8-1027
811412323D	F8-1027
811419831B	F8-4073
811419831B	LM-10026S
811498203	MK-822920
811511247	F8-1028
817253147	F8-4026
823199381B	F8-3000
823199381C	F8-6834
823199415B	F8-1031
823199415C	F8-1031
823199419	F8-5685
823253147A	F8-4026
823253147D	F8-4026
823407181	F8-4042
823411313A	F8-1029
823411327B	F8-5225
823412249	F8-3036
823419831	F8-4070
823511247A	F8-5686
861407183	F8-5132
861411313E	F8-5148
861419831B	F8-5044
861511271	F8-6232
867199383A	F8-6832
867411313	F8-5148
867512131	F8-5584
871412323A	F8-5738
883412249	F8-3036
893199381B	F8-3000
893199381C	F8-6834
893199415	F8-1031
893199419	F8-1032
893407181	F8-3057
893412131B	F8-4062
8A0199379E	F8-5529
8A0199415B	F8-5528
8A0199419	F8-5527
8A0253147A	F8-4027

VW	
8A0407181	F8-4043
8A0412323B	F8-1027
8A0412323D	F8-1027
8A0501541	F8-3052
8D0121275	F8-5526
8D0199339A	F8-5524
8D0199339E	F8-6758
8D0199339F	F8-4019
8D0199339P	F8-4019
8D0199379J	F8-5565
8D0199379K	F8-5567
8D0199382AP	F8-5579
8D0199382L	F8-5538
8D0199382M	F8-5579
8D0399151H	F8-5578
8D0399151J	F8-5577
8D0399151M	F8-5576
8D0399151R	F8-8179
8D0399415D	F8-5575
8D0399415E	F8-8012
8D0399419G	F8-5574
8D0407515A	F8-7796
8D0407515B	F8-7796
8D0407515C	F8-7796
8D0412065	F8-6282
8D0412065	F8-7096
8D0412065D	F8-6283
8D0412065D	F8-7097
8D0412065DS	F8-7097
8D0412065E	F8-6283
8D0412065E	F8-7097
8D0412065ES	F8-7097
8D0412065F	F8-6283
8D0412065F	F8-7097
8D0412065FS	F8-7097
8D0412065S	F8-7096
8D0412131E	F8-6039
8D0412131F	AK-735101
8D0412131F	F8-5994
8D0412131H	AK-735101
8D0419831K	LM-10021S
8D0498998	G8-529
8D0498998PART	G8-529
8D0501541A	F8-5573
8D0501541D	F8-5343
8E0501521N	F8-6431
8E0501522N	F8-6430
8E0513353B	F8-5572
8E0513353B	F8-6344
8E0513353C	F8-5572
8E0513353C	F8-6344
8N0407181B	F8-6464

VW	
8N0407182A	F8-6775
8N0422831	LM-10020S
8Z0411314B	F8-7914
8Z0412331	F8-5537
8Z0412331	F8-6281
9013230285	F8-5261
9013240050	F8-5979
9013240150	F8-5019
9013240250	F8-5788
9013260081	F8-5846
WHT004573	F8-5202K1
ZBA121273	F8-4011
ZBA121275	F8-4011
ZBC512131A	F8-5673



FEBI		FEBI		FEBI		FEBI	
01021	F8-5311	01678	F8-5324	02044	F8-4100	03094	F8-5143
01022	F8-5322	01698	F8-5688	02047	F8-4101	03098	F8-5707
01023	F8-5321	01706	F8-5689	02063	F8-5692	03100	F8-7584
01079	F8-5670	01750	F8-8144	02068	F8-5396	03101	F8-5710
01083	F8-5671	01828	F8-5690	02070	F8-4090	03140	G9-591
01085	F8-5120	01837	G9-594	02128	F8-5110	03141	G9-591
01088	F8-5672	01838	G9-593	02137	F8-4006	03142	G9-592
01091	F8-5554	01846	F8-6777	02183	F8-5109	03143	F8-5107
01101	F8-1025	01846	F8-6778	02223	F8-4097	03180	LM-10045S
01105	F8-1021	01857	F8-7053	02230	F8-1006	03180	M-822300
01107	F8-1015	01860	F8-5691	02263	F8-5108	03180	MK-822300
01109	F8-3041	01873	F8-3024	02273	F8-5552	03191	F8-5589
01110	F8-4030	01874	F8-3026	02329	F8-5694	03194	F8-3059
01111	F8-3039	01876	F8-3009	02345	F8-5582	03212	F8-5333
01117	F8-1034S	01907	F8-4029	02354	F8-5297	03304	F8-5038
01128	F8-4071	01908	F8-5531	02365	F8-4013	03310	LM-10027S
01128	LM-10031S	01924	F8-4036	02378	F8-6832	03319	F8-5044
01138	F8-4072	01925	F8-5100	02388	F8-6498	03320	LM-10052S
01172	F8-4008	01926	F8-1018	02395	F8-4037	03330	F8-3044
01173	F8-5673	01927	F8-3001	02417	F8-4082	03331	F8-6834
01199	F8-1010S	01928	F8-3002	02429	F8-1027	03332	AK-733023
01201	F8-1016S	01929	F8-4019	02497	F8-5697	03334	F8-4080
01220	F8-4008S	01930	F8-5524	02498	F8-5698	03373	F8-5463
01238	F8-4025	01931	F8-4035	02536	F8-4074	03374	F8-6324
01303	F8-5678	01932	F8-3057	02536	LM-10064S	03390	F8-7743
01304	F8-5679	01933	F8-7047	02537	F8-4069	03428	F8-5005
01311	G9-633	01934	F8-3005	02537	LM-10024S	03456	F8-1009C
01312	G9-634	01935	F8-4070	02537	LM-10050S	03461	F8-1029
01331	F8-3007	01952	F8-5181	02556	F8-1009B	03487	F8-1023
01365	F8-3008	01955	F8-5458	02557	F8-4064	03544	F8-6699
01366	F8-7453	01967	F8-5030	02567	F8-5704	03550	F8-1004
01367	F8-5683	01975	F8-7130	02581	M-820820	03567	F8-6239
01478	F8-5119	01982	F8-5113	02581	MK-820820	03578	F8-3046
01505	F8-5684	01987	F8-5149	02680	F8-3000	03595	F8-7722
01509	F8-4011	01989	F8-7103	02682	G9-527	03595	M-830220
01517	F8-1020	01991	F8-7103	02716	M-822900	03595	MK-830220
01518	F8-5685	02008	G9-590	02716	MK-822920	03595	MK-830220
01523	F8-3006	02009	F8-5304	02728	F8-6240	03596	F8-7722
01524	F8-6232	02014	F8-5112	02751	F8-1005	03599	F8-3040
01525	F8-5594	02015	F8-5334	02753	F8-1003	03604	F8-3048
01527	F8-5016	02023	F8-5445	02757	F8-5148	03605	F8-3045
01529	F8-4032	02024	F8-8166	02765	F8-5147	03628	F8-5015
01530	F8-4034	02025	F8-5441	02766	F8-5146	03663	F8-4061
01553	F8-5686	02026	F8-5437	02848	F8-5705	03664	F8-1016
01668	F8-5021	02027	F8-5373	02881	F8-5205	03665	F8-1014
01671	F8-5118	02028	F8-5371	02901	F8-5010	03671	F8-1010
01672	F8-5117	02030	F8-6883	02903	F8-5145	03688	F8-3054
01673	F8-5115	02032	F8-5444	02967	F8-5144	03784	F8-5007
01674	F8-5114	02033	F8-5442	03081	F8-5366	03786	F8-5459
01677	F8-5323	02034	F8-8145	03091	F8-4098	03829	F8-5370

FEBI		FEBI		FEBI		FEBI	
03874	F7-2059	05128	F8-5439	06663	G9-624	07560	F8-5419
03885	F8-5331	05131	F8-5436	06667	F8-5744	07590	F8-1012
03903	F8-7355	05155	F8-5501	06674	F8-5018	07601	F8-5018
04037	G9-639	05155	F8-7973	06676	F8-6230	07605	F8-8180
04046	F8-6740	05163	F8-6766	06730	F8-4009	07609	F8-5543
04050	F8-5367	05164	F8-6765	06739	F8-5432	07620	F8-1028
04060	F8-5069	05214	F8-5735	06739	F8-6757	07622	F8-5342
04095	F8-6762	05215	F8-5736	06766	F8-4033	07623	F8-5344
04103	F8-5178	05216	F8-5106	06795	F8-5746	07629	F8-1024
04112	F8-6242	05217	F8-5140	06843	F8-6826	07642	F8-4028
04124	F8-7022	05263	F8-4001	06985	F8-5747	07701	F8-5132
04181	F8-5317	05290	F8-4039	07059	F8-5105	07837	F8-5392
04229	F8-5718	05301	F7-2003	07107	F8-3047	07837	F8-5392S
04250	F8-5332	05302	F8-2005	07120	F8-4012	07843	G9-522
04305	F8-3060	05388	F8-5176	07121	F8-1011	07847	F8-1008
04306	F8-4102	05399	F8-7876	07122	F8-4016	07856	G9-648
04348	F8-5720	05492	F8-5738	07124	F8-4017	07857	F8-1007
04383	F8-5721	05495	F8-5739	07144	F8-5377	07868	F8-5501
04390	F8-4099	05622	F8-5204	07145	F8-5547	08002	F8-5131
04402	F8-5722	05657	F8-8101	07147	F8-5546	08014	F8-5129
04407	F8-5723	05747	G7-767	07171	F8-4021	08015	F8-5762
04443	F8-5724	05764	F8-5562	07172	F8-6748	08017	F8-5763
04517	F8-6491	05841	F7-9001	07175	F8-6241	08029	F8-4073
04519	F8-5738	05863	F7-2003	07177	F8-6750	08029	LM-10026S
04584	F8-5417	05864	F8-5449	07179	F8-5528	08032	F8-5506
04676	F8-4018	05898	F8-7678	07180	F8-1031	08049	F8-8194
04693	F8-5428	06043	G9-688	07182	F8-1032	08066	F8-7701
04696	F8-5430	06048	F8-5741	07183	F8-3053	08071	F8-5765
04697	F8-5431	06077	G9-637	07184	F8-5398	08144	F8-5101
04888	F8-1019	06085	F8-5613	07185	F8-5397	08156	F8-5128
04911	F8-5003	06170	G9-500	07186	F8-5346	08157	F8-5448
04913	F7-2002	06172	G9-501	07197	F8-5750	08173	F8-4106
04977	F8-4005	06172	G9-501S	07199	F8-5751	08176	F8-5450
04981	G9-514	06179	G9-524	07200	F8-5752	08179	F8-5434
04984	F8-4022	06213	G9-689	07205	F8-5753	08270	F8-5766
04990	F8-1022	06224	F8-5206	07220	F8-5418	08276	F8-5767
04995	F8-5020	06225	F8-5207	07224	G9-625	08303	F8-4081
04996	F8-5730	06226	F8-5137	07224	G9-625S	08384	F8-4063
05002	F8-5731	06350	F8-5011	07225	F7-2039	08403	G9-588
05003	F8-5732	06353	G9-667	07299	F8-5755	08428	F8-5769
05024	F8-5399	06404	F8-5014	07358	F8-4027	08432	F8-5420
05027	F7-2001	06427	F8-5004	07359	F8-1002	08453	F8-4062
05046	F8-4066	06544	F7-2055	07384	F8-1001	08510	F8-7054
05052	F8-5733	06559	G9-540	07473	F8-5391	08538	F8-4002
05059	F8-1013	06561	G9-541	07475	F8-5462	08539	F8-4003
05067	F8-4075	06621	F8-5438	07538	F8-1017	08561	F8-5009
05067	LM-10006S	06624	F8-8174	07540	F8-6235	08562	F8-6804
05114	F7-9001	06657	F8-5467	07557	F8-1026	08563	F8-6805
05126	F8-5372	06660	G9-623	07558	F8-4043	08619	F8-1034
05127	F8-5468	06661	G9-624	07559	F8-1009B	08669	F8-5502



FEBI		FEBI		FEBI		FEBI	
08681	F8-5770	09181	F8-6312	09674	F8-5195	10276	F8-5062
08687	F8-5256	09188	F8-5389	09688	F8-6866	10277	F8-5077
08740	F7-2069	09189	F8-5185	09741	G9-569	10280	F8-6823
08782	F8-5426	09190	F8-6468	09742	F8-5810	10289	F8-5630
08782	F8-6828	09191	F8-5788	09743	F8-5499	10290	F8-5828
08783	F8-5425	09203	F8-6763	09743	F8-6222	10291	F8-5829
08783	F8-6829	09209	F8-5075	09747	F8-6473	10292	F8-5830
08818	G9-503	09225	F8-5494	09795	F8-5811	10303	G9-571
08842	G9-544	09226	F8-5523	09816	F8-5329	10304	G9-598
08857	F7-2041	09227	F8-4067	09818	F8-5508	10307	F8-5363
08858	F8-5772	09228	F8-6280	10014	F8-5545	10356	F8-5477
08940	F8-5773	09282	F8-4093	10015	F8-4023	10379	F8-5023
08945	F8-5076	09373	G9-547	10016	F8-3003	10387	M-870870
08946	F8-5076	09374	F8-5798	10017	F8-3004	10387	MK-870870
08955	F8-5774	09377	F8-5799	10018	F8-4044	10404	F8-5197
08965	F8-5775	09378	F8-5475	10019	G9-616	10431	F8-6656
09005	G9-658	09379	F8-5474	10020	F8-4045	10446	F8-1027
09005	G9-658S	09380	G9-604	10021	G9-664	10651	F8-5017
09015	F8-3025	09381	G9-603	10022	F8-5063	10677	F8-8147
09019	F8-5078	09384	F8-5800	10023	F8-5064	10731	F8-5834
09019	G9-523	09385	F8-5801	10026	F8-5530	10732	F8-5364
09019	G9-523S	09386	G9-674	10027	F8-4086	10800	G9-617
09020	F8-5518	09387	G9-675	10073	G9-615	10814	G9-649
09044	F8-5578	09388	F8-5802	10087	F8-5473	10816	F8-5835
09045	F8-5577	09389	F8-5803	10089	F8-3032	10817	F8-5836
09046	F8-5576	09390	F8-5074	10090	F8-3033	10818	F8-5837
09047	F8-5341	09391	F8-5071	10091	F8-3012	10819	F8-5380
09047	F8-5341S	09393	F8-5805	10101	F8-5813	10823	F8-5496
09054	F8-3052	09394	F8-8199	10102	F8-6379	10824	F8-6329
09055	F8-7921	09395	G9-676	10115	F8-5527	10843	F8-5839
09056	F8-5777	09396	G9-677	10124	F8-8178	10849	LM-10063S
09057	F8-5519	09397	F8-5806	10125	F8-5308	10850	F8-5061
09058	G9-520	09398	F8-5807	10126	F8-6924	10850	LM-10088S
09060	F8-5104	09400	F8-5375	10142	F8-5405	10852	F8-4038
09070	G9-525	09401	F8-5492	10149	F8-5125	10861	F8-7153
09086	F8-5306	09404	F8-5307	10150	G9-567	10862	F8-6294
09087	F8-5778	09467	F8-5808	10151	G9-568	10863	F8-6295
09095	F8-4060	09471	F8-5522	10154	F8-5820	10873	F8-6704
09118	G9-586	09473	F8-5447	10155	F8-5821	10874	F8-6700
09119	G9-585	09478	F8-5483	10181	F8-3012	11107	F8-7747
09120	F8-5779	09479	F8-5464	10182	F8-6292	11111	F8-5500
09122	F8-5412	09480	F8-6495	10183	F8-6293	11136	F8-5327
09137	F8-5136	09483	F8-5485	10226	F8-5484	11152	F8-5309
09142	F8-5785	09491	F8-5411	10227	F8-5481	11155	F8-5198
09143	F8-5786	09494	F8-5070	10228	F8-5068	11192	F8-6813
09145	F8-5111	09496	F8-5507	10248	F8-5825	11192	F8-6814
09146	G9-570	09511	F8-5410	10251	F8-5150	11483	F8-5538
09153	F8-5461	09519	F8-3042	10252	F8-5072	11484	F8-5529
09154	F8-5460	09522	F8-3010	10256	F8-5826	11485	F8-5565
09180	F8-5413	09587	F8-5340	10257	F8-5827	11486	F8-5579

FEBI		FEBI		FEBI		FEBI	
11500	F8-5135	12072	F8-5513	12470	F8-5447S	13042	AK-735022
11569	F8-5504	12081	F8-5598	12471	F8-6511	13043	AK-735023
11570	F8-5503	12082	F8-5858	12472	G9-641	13044	AK-735024
11608	F8-3014	12083	F8-5600	12506	F8-5415	13045	AK-735025
11662	F8-4090	12089	F8-3013	12508	F8-5886	13046	AK-735026
11663	F8-5130	12090	F8-5612	12519	F8-5433	13047	AK-735027
11667	F8-6378	12102	F8-5051	12594	F8-3036	13048	AK-735028
11698	F8-5520	12102	LM-10023S	12626	F8-5320	13049	AK-735029
11701	F5-1007	12121	F8-5427	12627	F8-5319	13050	AK-735030
11755	F8-5099	12128	F8-3049	12628	F8-5318	13051	AK-735031
11756	G9-556	12129	F8-3044	12629	F8-5887	13052	AK-735032
11759	F8-5066	12150	F8-5088	12642	LM-10012S	13056	AK-735116
11777	G9-555	12155	F8-6504	12646	F8-5171	13059	AK-735033
11777	G9-558	12156	F8-6489	12646	LM-10011S	13060	AK-735034
11782	F8-5351	12159	F8-6221	12674	F8-5501S	13061	AK-735035
11864	F8-5846	12161	F8-5860	12676	F8-5304S	13062	AK-735117
11970	F8-5622	12163	F8-5862	12685	F8-5083	13063	AK-735036
11971	F8-5621	12164	F8-5087	12700	F8-5632	13064	AK-735037
11971	F8-7164	12170	F8-5863	12703	F8-5030	13066	AK-735257
11972	F8-7164	12244	F8-5864	12732	F8-6902	13067	AK-735086
11973	F8-6304	12292	G9-508	12734	F8-6935	13072	AK-735119
11974	F8-6304	12293	F8-6413	12736	F8-3017	13074	AK-735070
11993	F8-6331	12294	F8-5865	12737	F8-5515	13076	AK-735039
12000	F8-5850	12295	F8-5866	12738	F8-6381	13077	AK-735040
12008	F8-5852	12296	F8-5867	12763	F8-5897	13096	AK-735126
12009	F8-5852	12309	F8-5563	12764	F8-5898	14038	F8-3050
12017	F8-5090	12340	F8-5869	12799	F8-5027	14043	F5-1001
12018	F8-5098	12344	F8-5870	12895	F8-5899	14047	F8-5901
12019	F8-5482	12346	F8-6496	12927	F8-5123	14064	F5-1009
12022	F8-4110	12368	F8-5871	13001	AK-733023	14081	F8-4043
12026	F8-7154	12372	F8-5086	13004	AK-735003	14146	F8-5081
12027	F8-6306	12373	F8-5085	13005	AK-735005	14154	F8-5343
12028	F8-5354	12375	F8-5084	13006	AK-735010	14156	F8-5904
12028	F8-8066	12376	F8-5642	13008	AK-735011	14158	F8-5905
12029	F8-5353	12377	G9-512	13011	AK-735012	14164	F8-5906
12029	F8-8067	12381	F8-5872	13012	AK-735004	14179	F8-5424
12030	F8-3023	12399	F8-5873	13013	AK-735005	14187	F8-5423
12031	F8-6306	12400	F8-5874	13014	AK-735013	14188	F8-5422
12031	F8-7154	12412	F8-6483	13015	AK-735006	14189	F8-6921
12050	F8-5349	12415	F8-5026	13016	AK-735014	14190	F8-6891
12051	F8-5855	12427	F8-5352	13017	AK-732516	14191	F8-6888
12052	F8-5536	12441	AK-735038	13019	AK-735015	14192	F8-6520
12054	F8-5096	12441	F8-5878	13020	AK-735016	14231	G9-663
12055	F8-4109	12445	F8-5879	13022	AK-735017	14232	G9-662
12063	F8-5094	12448	F8-3020	13023	AK-735111	14276	F8-5907
12066	F8-5092	12449	F8-5880	13030	AK-735112	14396	F8-5392S
12068	F8-5514	12450	F8-5409	13032	AK-735018	14398	F8-5340
12069	F8-5513	12451	F8-3018	13034	AK-735019	14491	F8-6485
12070	F8-3015	12454	F8-6307	13038	AK-735020	14492	F8-6918
12071	F8-5514	12469	F8-3019	13039	AK-735021	14505	F8-5505



FEBI		FEBI		FEBI		FEBI	
14505	F8-6313	15088	F8-5927	15718	F8-5368	17257	F8-5962
14507	F8-5406	15090	F5-1005	15719	F8-8071	17286	F8-5963
14520	F8-1007S	15154	F5-1017	15721	F8-8195	17287	F8-5964
14524	F8-5416	15155	F5-1018	15722	F8-6836	17292	F8-5966
14527	F8-5080	15156	F5-1040	15824	F8-7722	17317	F8-5967
14547	F8-8142	15157	F5-1026	15869	F8-6494	17317	F8-6380
14548	F8-5911	15158	F5-1042	15870	F8-5537	17320	F8-5968
14549	F8-5337	15165	F5-1003	15877	F8-5556	17321	F8-5969
14552	F8-6835	15252	F5-1008	15880	F8-6236	17376	F8-5201
14553	F8-6217	15254	F5-1006	15898	F8-5934	17442	F8-8137
14593	F8-5913	15256	F5-1043	15908	F8-5404	17443	F8-8183
14599	F8-6739	15258	F5-1012	15910	F8-5386	17452	F8-5335
14669	F8-5914	15260	F5-1002	15912	F8-5383	17453	F8-5336
14716	F8-5221	15262	F5-1004	15913	F8-5935	17471	F8-5970
14718	F8-5220	15264	F5-1011	15915	F8-5936	17473	F8-5227
14739	F8-5252	15274	F5-1013	15919	F8-5937	17540	F8-7722
14845	F8-5915	1530	F8-4034	15925	F8-5938	17618	F8-5971
14845	F8-6385	15380	F8-5215	15925	F8-7595	17680	F8-5973
14847	F8-7354	15381	F8-5210	15928	F8-6922	17681	F8-5216
14891	F8-5254	15393	F8-5929	15932	F8-7041	17682	F8-5974
14897	F8-5916	15401	F8-5249	15954	F8-5491	17709	F8-5978
14899	F8-5917	15408	F8-5242	15978	F8-5235	17729	F8-5211
14903	F8-5918	15409	F8-5603	15980	F8-5224	17730	F8-5230
14914	F8-5919	15417	F8-5930	15982	F8-4057	17735	F8-6237
14915	F8-5920	15424	F8-6548	15984	F8-4058	17736	F8-6505
14916	F8-5921	15429	F8-5932	15986	F8-5225	17771	F8-5245
14917	F8-5922	15431	F8-5570	17039	G9-643	17781	F8-5248
14922	F8-5923	15520	F8-5231	17089	F8-6466	17790	G9-549
14923	F8-5311	15522	F8-5229	17107	F8-5945	17795	F8-5979
14941	F8-5488	15525	F8-5236	17108	F8-5946	17801	F8-5517
14942	F8-5214	15533	F8-5348	17109	F8-5947	17803	F8-5516
14943	F8-6376	15600	F8-5933	17110	F8-5948	17805	F8-5222
14944	F8-5219	15620	F8-5228	17111	F8-5949	17807	F8-5980
14945	F8-5813	15621	F8-5338	17112	F8-5950	17816	F8-5019
14948	F8-5218	15635	F8-5365	17113	F8-5951	17817	F8-5213
14949	F8-5253	15636	F8-6755	17132	F8-5952	17839	F8-5981
14950	F8-5217	15638	F8-8155	17157	F8-6262	17841	F8-5982
14951	F8-5480	15643	F8-5641	17158	F8-6308	17860	F8-6216
14952	F8-5209	15644	F8-6885	17163	F8-6479	17861	F8-8182
14954	F8-5403	15645	F8-6886	17171	F8-5956	17862	F8-8181
14954	F8-6382	15646	F8-6822	17178	F8-5957	17865	F8-5983
14956	F8-5402	15647	F8-6827	17179	F8-5958	17866	F8-6267
14956	F8-6382	15660	F8-6215	17180	F8-3027	17867	F8-5984
14958	F8-5402	15669	F8-6931	17186	F8-6319	17990	F8-5246
14958	F8-5403	15671	F8-6632	17187	F8-3062	17991	F8-5247
14958	F8-6382	15673	F8-6936	17188	F8-5604	18027	LM-10004S
14972	F8-6896	15674	F8-6939	17191	F8-5599	18042	LM-10039S
14973	F8-6940	15691	F8-6492	17193	F8-5591	18073	F8-5325
14997	F5-1015	15692	F8-6506	17195	F8-5592	18074	F8-5326
14997	F5-1032	15693	F8-6833	17197	F8-5226	18075	F8-6231

FEBI		FEBI		FEBI		FEBI	
18177	G9-698	18699	F8-6019	19451	F8-6048	19975	F8-6631
18179	G9-699	18733	F8-6020	19452	F8-5330	21039	F8-6079
18180	F8-3036	18734	F8-6021	19453	F8-5407	21066	F8-6080
18183	F8-5988	18735	F8-7167	19456	F8-6647	21101	F8-6084
18185	LM-10072S	18736	F8-5359	19457	G9-532	21103	F8-6085
18225	F8-8159	18743	F8-6500	19458	G9-531	21105	F8-6086
18229	F8-8160	18745	F8-6497	19459	G9-530	21107	F8-6087
18239	F8-6509	18746	F8-6486	19465	F8-8175	21111	F8-6088
18241	F8-6903	18751	F8-5566	19472	F8-6052	21112	F8-6542
18299	F8-5261	18754	F8-6026	19473	F8-6053	21113	F8-6543
18300	F8-8224	18757	F8-7163	19475	G9-612	21124	F8-6091
18313	F8-5989	18758	F8-6299	19476	G9-584	21132	G9-651
18315	F8-5990	18760	F8-6898	19477	G9-533	21142	F8-8226
18343	F8-5669	18830	F8-4053	19478	F8-6057	21169	LM-10002S
18347	F8-5251	18844	G9-617	19490	F8-5384	21170	LM-10001S
18356	F8-5992	18856	F8-7749	19492	F8-5387	21170	LM-10042S
18358	F8-5993	18858	F8-7748	19494	F8-5385	21171	LM-10000S
18360	F8-5994	18864	F8-5394	19495	F8-6058	21172	LM-10036S
18361	F8-7598	18866	F8-4040	19512	F8-6059	21174	F8-5297
18364	F8-5995	18874	F8-5378	19517	F8-6060	21193	F8-6760
18365	F8-5996	18875	F8-5453	19519	F8-6061	21194	G9-615
18372	F8-7693	18876	F8-6034	19594	F8-6471	21201	F8-7721S
18374	F8-6001	18897	F8-5299	19596	F8-6470	21218	F8-5540
18375	F8-6002	18901	F8-7353	19616	F8-6063	21220	F8-6923
18376	F8-6003	18917	F8-5571	19617	F8-6064	21222	F8-7948
18377	F8-6004	19009	F8-5355	19675	F8-6066	21226	F8-8189
18378	F8-6005	19011	F8-6507	19676	F8-6318	21240	F8-5567
18379	F8-6006	19015	F8-6508	19679	F8-6950	21250	F8-6096
18380	F8-6007	19017	F8-6487	19680	F8-6951	21261	F8-6097
18381	F8-6008	19019	F8-8149	19713	F8-5569	2128	F8-5110
18400	F8-6012	19044	F8-4052	19729	F8-6073	21332	F8-6098
18402	F8-6013	19048	F8-7043	19796	F8-6925	21401	F8-6100
18481	F8-6014	19050	F8-5395	19802	F8-5544	21402	F8-6100
18481	F8-6384	19101	F8-6037	19804	F8-4031	21463	F8-6102
18492	F8-5541	19102	F8-6038	19829	F8-6074	21464	F8-6103
18495	F8-6015	19109	F8-6761	19832	F8-5408	21468	F8-6105
18497	F8-6016	19111	F8-7720S	19899	F8-6502	21469	F8-6106
18508	F8-6499	19124	F8-5271	19901	F8-5478	21470	F8-6107
18509	F8-7879	19273	F8-6039	19904	F8-7951	21471	F8-6108
18548	F8-5262	19274	F8-6040	19906	F8-8164	21472	F8-6109
18552	F8-5263	19277	F8-5584	19908	F8-8173	21473	F8-6110
18604	F8-6017	19280	F8-6041	19909	F8-6488	21517	F8-7797
18607	F8-5607	19281	F8-6042	19911	F8-5490	21530	F8-6112
18686	F8-5280	19286	F8-6044	19917	LM-10014S	21540	F8-6113
18686	F8-5281	19288	F8-6045	19924	F8-6510	21611	F8-6114
18686	G8-544	19381	F8-5362	19926	F8-5542	21613	F8-6115
18687	F8-5280	19414	F8-4076	19928	F8-6076	21613	F8-6452
18688	F8-5281	19414	LM-10029S	19930	F8-6077	21655	F8-6116
18696	F8-5358	19420	F8-5390	19938	F8-7102	21683	F5-1019
18698	F8-6018	19449	F8-5328	19969	F8-5357	21684	F5-1056





FEBI		FEBI		FEBI		FEBI	
21698	LM-10020S	22157	F8-6164	22703	F8-6994	23298	F8-7032
21735	F8-6133	22159	F8-6316	22711	F8-8148	23300	F8-7049
21750	F8-6118	22161	F8-7031	22714	F8-6593	23310	F8-6348
21757	F8-7151	22163	F8-7030	22715	F8-6594	23317	G8-559
21765	F8-6119	22238	F8-6166	22722	F8-8198	23318	F8-8227
21769	F8-6120	22239	F8-6167	22724	F8-7960	23318	G8-559
21785	F8-5487	22243	F8-6756	22726	F8-7961	23356	F8-7930
21814	F8-6125	22244	F8-6958	22732	F8-5489	23358	F8-7923
21816	F8-6127	22266	F8-6148	22762	F8-7981	23359	F8-6774
21818	F8-6128	22271	F8-6171	22766	F8-7982	23361	F8-6774
21820	F8-6129	22273	F8-6172	22786	F8-6467	23364	F8-4038
21821	F8-6130	22283	F8-6332	22794	F8-7901	23366	F8-6579
21822	F8-6131	22285	F8-8165	22804	F8-5215	23374	F8-8150
21850	F8-6134	22287	F8-6475	22804	F8-5221	23405	F8-5361
21852	F8-6135	22289	F8-6174	22818	F8-7992	23410	F8-6723
21852	F8-6135S	22295	F8-6175	22819	F8-7989	23418	F8-7707
21853	F8-6136	22299	F8-6472	22821	F8-7990	23424	F8-4056
21855	F8-6137	22305	F8-7633	22822	F8-7988	23430	F8-7140
21886	F8-6501	22307	F8-6176	22854	F8-6661	23442	F8-7576
21934	F8-6143	22311	F8-6177	22865	F8-6523	23444	F8-7600
21937	F8-8154	22394	F8-6549	22866	F8-6662	23446	F8-7176
21938	F8-8126	22438	F8-5298	22867	F8-6662	23448	F8-7834
21940	F8-4055	22445	F8-6181	22929	F8-7455	23450	F8-7831
21943	F8-4015	22446	F8-6182	22932	F8-8152	23452	F8-7579
21958	F8-6144	22450	F8-6184	22934	F8-7962	23458	F8-7809
21968	F8-6145	22492	F8-6190	22943	F8-7431	23460	F8-7131
22019	F8-5356	22494	F8-6191	22954	F8-6736	23470	F8-7471
22039	F8-6148	22498	F8-6569	22956	F8-6892	23474	F8-6430
22043	F8-6148	22500	F8-6570	22961	F8-6759	23474	F8-6431
22046	F8-6151	22502	F8-6284	22970	F8-5526	23478	F8-7578
22097	F8-6926	22533	LM-10061S	22982	F8-6430	23504	F8-7714
22099	F8-6659	22617	F8-6335	22984	F8-6431	23510	F8-7046
22100	F8-6153	22619	F8-6195	22986	F8-5380	23518	F8-7658
22101	F8-6154	22635	F8-5629	22988	G9-665	23533	F8-7056
22102	F8-6155	22636	F8-6535	23003	F8-6447	23537	F8-7599
22106	F8-6482	22638	F8-6196	23012	F8-6991	23576	F8-7707
22108	F8-5433	22639	F8-6197	23014	F8-6988	23580	F8-7833
22127	F8-6297	22640	F8-7680	23018	F8-7958	23582	F8-7832
22128	F8-7009	22645	F8-7028	23020	F8-6989	23584	F8-6758
22129	F8-6156	22648	F8-6198	23022	F8-6528	23586	F8-7580
22130	F8-6296	22654	F8-6651	23024	F8-6349	23588	F8-7601
22131	F8-6302	22657	F8-6529	23046	F8-7922	23590	F8-7697
22136	F8-6157	22659	F8-6811	23058	F8-7010	23608	F8-7830
22137	F8-6158	22660	F8-6812	23108	F8-7033	23610	F8-7675
22138	F8-6159	22661	G9-652	23116	F8-6540	23614	F8-7703
22139	F8-6160	22673	F8-6992	23125	F8-6732	23620	F8-4026
22141	F8-6161	22685	F8-6993	23130	F8-6961	2364	F8-7744
22151	F8-6484	22686	F8-6882	23131	F8-6469	23672	F8-8170
22153	F8-6162	22687	F8-8156	23138	F8-8179	23680	F8-6975
22155	F8-6163	22699	F8-6638	23140	F8-8143	23681	F8-6980

FEBI		FEBI		FEBI		FEBI	
23690	F8-6358	24916	F8-6639	26643	F8-6250	27324	F8-6694
23725	F8-8192	24918	F8-7915	26644	F8-6251	27330	F8-6702
23751	F8-8188	24933	F8-5648	26665	F8-7037	27340	F8-7641
23762	F8-7946	24934	F8-5656	26666	F8-7038	27362	F8-7329
23765	F8-6944	24935	F8-5657	26667	F8-7038	27400	F8-6137
23769	F8-6942	24948	F8-6203	26713	F8-6998	27444	F8-6391
23770	F8-6943	26032	F8-7604	26725	F8-6351	27446	F8-6601
23811	F8-6503	26035	AK-735174	26777	F8-6465	27453	F8-7993
23876	F8-7048	26035	F8-7335	26799	F8-6327	27455	F8-6526
23878	F8-6532	26036	AK-735176	26800	F8-6327	27456	F8-6525
23880	F8-5551	26104	F8-7331	26801	F8-6995	27457	F8-6338
23882	F8-6533	26127	F8-7912	26802	F8-6996	27457	F8-6526
23882	F8-7952	26128	F8-7974	26825	F8-5663	27458	F8-6525
23884	F8-6945	26135	F8-5649	26826	F8-5472	27458	F8-7057
23918	F8-5535	26140	F8-5654	26834	F8-5202	27459	F8-7152
23943	F8-7359	26143	F8-7741	26834	F8-5202K1	27484	F8-6784
23944	F8-6347	26148	F8-6783	26870	F8-6396	27504	F8-6596
23959	F8-6764	26177	F8-7334	26872	F8-6398	27505	F8-6339
23961	F8-6767	26179	F8-7332	26874	F8-6572	27539	F8-6597
23988	F8-7972	26183	F8-7700	26875	F8-7812	27638	F8-6462
23992	F8-8191	26193	F8-8190	26876	F8-6573	27640	F8-6461
24030	F8-8185	26263	F8-5300	26877	F8-7725	27642	F8-6460
24057	F8-8172	26304	F8-7977	26922	F8-5660	27720	F8-5659
24081	F8-8201	26308	F8-8163	26923	F8-5643	27721	F8-5646
24179	F5-1014	26325	LM-10056S	26924	F8-5644	27722	F8-5647
24187	F8-7935	26326	F8-6753	26929	F8-6517	27822	F8-6393
24189	F8-6426	26327	F8-8158	26930	G8-559	27823	F8-7087
24220	F8-7903	26328	F8-8161	26935	F8-8214	27824	F8-7086
24221	F8-7373	26332	F8-6768	26941	F8-7684	27837	F5-1121
24225	F8-7934	26344	F8-5215	26957	F8-5645	27839	F5-1111
24239	F8-6724	26360	F8-7451	26958	F5-1103	27840	F5-1114
24240	F8-6724	26367	F8-6400	26969	F8-8153	27841	F5-1081
24242	F8-6166	26381	F8-7745	26984	F8-6641	27847	F8-7699
24245	F8-7913	26409	F8-5321	26985	F8-6640	27848	F8-7662
24247	F8-6481	26460	F8-6281	27038	F8-7798	27880	F8-6112
24262	F8-6673	26465	F8-5287	27069	F8-6425	27913	F8-8078
24263	F8-6674	26477	F8-6968	27071	F8-6424	27973	F8-7661
24266	F8-6368	26481	F8-6967	27086	LM-10078S	27996	F8-7172
24308	F8-8203	26507	F8-7145	27115	F8-7605	27997	F8-7330
24309	F8-8193	26518	F8-6973	27128	F8-6478	27999	F8-5334
24390	F8-5633	26535	F8-6464	27160	F8-7996	28100	G9-594
24403	F8-6539	26540	G7-1001	27181	F8-6687	28101	F8-5969
24413	F5-1039	26560	F8-7008	27215	F8-5639	28115	F8-7327
24552	F8-5476	26564	F8-7679	27230	F8-6388	28116	F8-7328S
24591	F8-8202	26573	F8-5303	27231	F8-6389	28118	F8-7328
24593	F8-6897	26577	F8-6357	27245	F8-8001	28174	F8-6515
24595	F8-6857	26584	F8-5388	27290	F8-7938	28198	F8-6680
24628	F8-5636	26596	F8-7473	27304	F8-5215	28203	F8-8168
24753	F8-6660	26618	F8-6350	27318	F8-5220	28204	AK-735331
24889	F8-6387	26620	F8-5381	27319	F8-6254	28217	F8-7441



FEBI		FEBI		FEBI		FEBI	
28221	F8-6286	29644	G9-678	30106	F8-6983	31081	F8-5533
28221	F8-7427	29657	LM-10082S	30107	F8-6984	31083	F8-7956
28222	F8-6288	29665	F8-7819	30108	F8-6981	31096	F8-6395
28226	F8-6678	29666	F8-7820	30109	F8-6977	31098	F8-7643
28228	F8-7442	29674	F8-6683	30110	F8-6978	31100	F8-7645
28233	F8-6677	29682	F8-7907	30140	F8-7888	31102	F8-7084
28269	F8-7377	29689	F8-7908	30147	F5-1087	31106	F8-8102
28320	F8-6420	29690	F8-7902	30158	F8-7091	31113	F8-7950
28325	F8-8146	29706	F8-4059	30218	F8-7941	31123	F8-7955
28335	F8-5302	29709	F5-1126	30223	F8-6600	31124	F8-5534
28385	F8-7147	29747	F8-8140	30295	F8-7161	31124	F8-7949
28387	F5-1099	29751	F8-6648	30419	F8-7444	31127	F8-5532
28403	F8-6591	29762	F8-5580	30420	F8-7577	31127	F8-7954
28404	F8-6592	29766	F8-7443	30421	F8-7174	31146	F8-7040
28405	F8-7421	29771	F5-1065	30422	F8-7581	31212	F8-7651
28406	F8-7421	29774	F8-7446	30423	F8-7582	31253	F8-6736
28488	F8-6652	29776	F8-7445	30424	F8-7583	31266	F8-6718
28495	F8-7477	29838	F8-6714	30428	F8-8028	31267	F8-6776
28528	F8-6598	29839	F8-7448	30455	F8-7678	31271	F8-6730
28529	F8-7663	29904	F5-1046	30456	F8-7677	31279	F8-6969
28582	F8-6580	29938	F8-7909	30557	F8-7588	31291	F8-6317
28614	F8-7695	29944	F8-6582	30559	F8-7589	31292	F8-7431
28614	F8-7695S	29964	F5-1031	30582	F8-7590	31292	F8-8213
28621	F8-6775	29971	F8-7747	30583	F8-7585	31299	F8-8087
28660	F8-8141	30001	F8-6877	30604	F8-7944	31344	F8-6705
28661	F8-8167	30007	F8-6644	30623	F8-7926	31346	F8-7904
28712	F8-6585	30008	F8-6645	30687	F8-8133	31347	F8-7387
28733	F8-7995	30009	F8-6646	30691	F8-6701	31347	F8-8216
29185	F8-8042	30011	F8-6643	30696	F8-7796	31348	F8-7927
29195	F8-6651	30029	F5-1037	30714	F8-8004	31350	F8-7914
29280	F8-6729	30029	F5-1045	30715	F8-8003	31354	F8-6708
29312	F8-7746	30030	F8-6354	30786	F8-6210	31376	F8-6531
29333	F8-7082	30030	F8-7169	30841	F8-6268	31380	F8-7959
29366	F8-7144	30034	F8-6587	30842	F8-7156	31385	F5-1058
29367	F8-8230	30043	F8-7794	30888	F8-6524	31387	F8-7947
29397	F8-8157	30044	F8-7793	30916	F8-8014	31395	F8-6679
29406	F8-7129	30048	F8-6970	30917	F8-8015	31405	F5-1000
29450	F8-7795	30049	F8-6971	30944	F8-7694	31417	F8-6691
29452	F8-7671	30052	F8-8115	30970	F8-6734	31420	F8-6693
29475	F8-7631	30057	F8-8139	30972	F8-6733	31421	F8-7736
29478	F8-7478	30059	F8-8200	31007	F8-6796	31427	F8-7587
29498	F8-6599	30062	F8-8177	31008	F8-7942	31448	F8-7607
29502	F8-8151	30067	F5-1029	31009	F8-7905	31463	F8-5834
29510	F8-8138	30067	F5-1061	31013	F8-7001	31479	F8-7162
29540	F8-7932	30078	F8-6676	31014	F8-7002	31483	F8-7092
29568	F8-6463	30079	F8-6904	31015	F8-6999	31495	F8-7474
29586	F8-8162	30097	F8-7650	31016	F8-7000	31510	F8-6863
29587	F8-7469	30103	F8-6584	31017	F8-7006	31512	F8-6907
29593	F8-6522	30104	F8-6657	31064	F8-7976	31513	F8-6906
29601	F8-6668	30105	F8-6982	31066	F8-7919	31515	F8-6874

FEBI		FEBI		FEBI		FEBI	
31541	F5-1098	32273	F8-6620	33357	F8-6177	36065	F8-6277
31547	F8-5340	32275	F8-6617	33379	F8-7918	36065	G8-277
31655	F8-7591	32278	F8-6614	33381	F8-7931	36074	F8-7727
31694	F8-7928	32280	F8-6612	33382	F8-7917	36074	F8-7728
31698	F8-7807	32281	F8-6712	33390	F8-7494	36098	F8-7873
31699	F8-7836	32282	F8-6621	33391	F8-7575	36154	F8-7732
31722	F8-5340	32285	F8-6615	33574	F8-6574	36160	F8-6438
31729	F5-1051	32297	F5-1102	33575	F8-6575	36161	F8-6437
31734	F8-7803	32311	F5-1113	33625	F8-7739	36243	F8-6652
31743	F5-1053	32315	F5-1050	33719	F8-7742	36244	F8-7093
31754	F5-1123	32407	F8-7352	33725	F8-6707	36244	F8-7093S1
31791	F8-7911	32407	F8-7352S	33963	F8-6588	36270	F8-6640
31792	F8-7910	32418	F8-8078	34135	F8-7837	36281	F8-5264
3180	MK-822300	32422	F8-7468	34175	F8-6720	36282	F8-5265
31806	F8-6949	32423	F8-7467	34176	F8-6721	36285	F8-6773
31807	F8-6948	32470	F8-7857	34197	F8-7089	36287	F8-7644
31808	F8-6947	32470	F8-7857S	34249	F8-6638	36305	F8-7849
31809	F8-6946	32471	F8-6610	34277	F5-1143	36306	F8-7708
31958	F8-7966	32472	F8-6611	34283	F8-6247	36307	F8-7711
31959	F8-7965	32492	F8-8219	34285	F8-6290	36315	F8-7685
31978	F8-6990	32493	F8-7920	34288	F8-6545	36319	F8-6675
31980	F8-7971	32505	F5-1097	34288	F8-7336	36337	F8-6688
31984	F8-7452	32541	F8-6424	34289	F8-7738	36351	AK-735423
31986	F8-7034	32542	F8-6425	34295	F8-6711	36351	F8-7702
32026	F8-6392	32546	F8-7676	34391	F8-6289	36353	AK-735427
32028	F8-7933	32560	F8-7674	34455	F8-6333	36353	F8-7706
32029	F8-6752	32636	F8-7454	34456	F8-7157	36356	F8-7621
32030	F8-6742	32642	F8-6530	34547	F5-1044	36387	F8-8070
32031	F8-7939	32714	F8-7637	34570	F8-8130	36420	F8-7644
32033	F8-6744	32715	F8-8169	34571	F8-8129	36457	F8-7881
32035	F8-6747	32754	F8-7197	34589	F5-1085	36458	F8-7882
32036	F8-6583	32754	G8-197	34598	F5-1134	36459	F8-7883
32037	F8-6476	32755	F8-6272	34605	F5-1086	36460	F8-5303
32069	F8-7004	32755	G8-272	34612	F5-1064	36477	F8-7626
32070	F8-7005	32755	G8-276-501	34626	F8-3063	36496	F8-6731
32109	F8-7083	32757	F8-7937	34663	F5-1073	36529	F8-7689
32125	F8-7337	32787	F8-7635	34667	F5-1124	36530	F8-7690
32147	F8-5572	32789	AK-735444	34711	F5-1055	36531	F8-7691
32164	F8-6352	32916	F8-7628	34719	F8-6934	36532	F8-7692
32187	F8-5650	32917	F8-7628	34732	F8-7858	36543	F8-7925
32195	F8-7880	32955	F8-8094	34749	F8-7434	36569	F8-6670
32219	F8-5661	32969	F8-8176	34750	F8-7432	36578	F8-6745
32226	F8-7924	32999	F8-7466	34801	F8-7975	36604	F8-7682
32258	F8-7846	33049	F8-6638	34802	F8-6590	36605	F8-7681
32262	F8-6746	33088	F8-7710	34825	F8-6399	36614	F8-6367
32263	F8-6743	33117	F8-7705	34918	F8-7456	36615	F8-7158
32268	F8-6622	33132	F5-1036	34951	F8-7418	36625	F8-6571
32269	F8-6623	33133	F5-1025	34952	F8-6353	36638	F8-6074
32271	F8-6619	33133	F5-1063	36005	F8-4083	36681	F8-7003
32272	F8-6618	33160	F5-1041	36006	F8-7132	36689	F8-8171



FEBI		FEBI		FEBI		FEBI	
36700	F8-5378	37568	G9-534	39222	F8-7333	41460	F8-8021
36720	F8-7835	37597	F8-8088	39286	AK-735337	41467	F8-8017
36721	F8-7715	37601	F8-7170	39363	F8-8197	41470	F8-8017
36722	F8-7704	37647	F8-7900	39491	F8-7433	41473	F8-7824
36723	F8-7718	37750	F8-6266	39602	LM-10020S	41479	F8-7822
36724	F8-7719	37764	LM-10020S	39606	LM-10020S	41497	F8-8220
36725	F8-7716	37831	F8-7492	39624	F8-5662	41503	F8-7063
36726	F8-7717	37876	F8-1009B	39625	F8-6589	41506	F8-8023
36727	F8-7688	37982	F5-1140	39626	F8-6595	41508	F8-8024
36728	F8-7687	38219	F8-7606	39660	F8-8184	41511	F8-7076
36748	F8-6986	38227	F8-7608	39691	F8-7997	41513	F8-8217
36752	F8-7856	38228	F8-7847	39887	F8-8196	41522	F8-8016
36779	F8-7723	38239	F8-7686	39921	F5-1110	41535	F8-7067
36780	F8-7724	38240	F8-7683	40079	F8-8098	41547	F8-8018
36787	F8-7713	38263	F5-1135	40081	F8-8099	41552	F8-8014
36788	F8-7799	38264	F5-1100	40088	F8-7899	41555	F8-7074
36813	F8-6893	38267	F5-1075	40165	F8-5301	41561	F8-8123
36814	F8-8086	38268	F5-1151	40234	F8-7893	41578	F8-7827
36819	AK-735345	38308	F8-7421	40496	F8-8092	41580	F8-7826
36819	F8-7594	38339	MK-810160	40619	F8-8205	41585	F8-7829
36827	F8-6719	38358	F8-6044	40620	F8-8206	41586	F8-7066
36846	F8-7672	38366	F8-7891	40760	F8-7840	41589	F8-8020
36847	F8-7673	38367	F8-7815	40762	F8-7844	41590	F8-7067
36848	F8-7586	38388	F8-7892	40763	F8-7841	42010	F8-5278
36855	AK-735350	38393	F8-8002	40875	F8-6786	42012	F8-8005
36856	F8-7596	38399	F8-7851	41007	F8-8228	42018	F8-8027
36860	F8-7493	38547	F8-7999	41112	F8-6696	42022	F8-8031
36869	F8-7709	38558	F8-7816	41127	F8-8034	42023	F8-8030
36871	F8-7603	38573	F8-8079	41128	F8-8033	42042	F8-5278
36880	F8-5293	38637	F8-7640	41129	F8-8035	42045	F8-8029
36963	F8-8074	38657	F8-7627	41138	F8-6696	42053	F8-8028
36964	F8-8075	38659	F8-7991	41169	F8-8032	42257	F8-8125
36970	AK-735349	38683	F8-8106	41393	F8-7817	42258	F8-5289
36976	F8-7484	38720	F8-7079	41394	F8-7073	42264	F8-8223
36979	AK-735341	38782	F8-8132	41399	F8-7828	42265	F8-8222
36983	AK-735344	38789	F8-7624	41407	F8-7818	42324	F8-5284
36993	F8-6252	38811	F8-6706	41409	F8-7998	42327	F8-5282
37006	AK-735339	38930	LM-10010S	41410	F8-7828	42375	F8-8225
37010	AK-735348	38952	F8-6518	41412	F8-7820	42787	F8-7987
37011	AK-735066	38978	F8-6637	41416	F8-6576	42820	F8-8111
37014	F8-6911	38991	F8-6722	41417	F8-7821	42830	F8-8110
37030	F8-6516	38992	F8-7940	41424	F8-7070	42836	F8-8000
37039	F8-7594	39081	F8-8073	41428	F8-8025	42852	F8-8056
37127	F8-7842	39082	F8-8073	41429	F8-8026	42861	F8-8104
37137	F8-7839	39091	F8-7447	41434	F8-7065	42916	F8-8064
37138	F8-7843	39117	F8-7802	41436	F8-7061	42919	F8-8043
37165	F8-6562	39194	F8-8091	41438	F8-7061	43749	F8-8093
37253	F8-7929	39198	LM-10058S	41441	F8-8019	43786	F5-1146
37554	F8-7488	39207	F8-7877	41450	F8-8013	43953	F8-6245
37566	F8-7487	39208	F8-7878	41459	F8-7986	43955	F8-5277

**FEBI**

43955	F8-6244
44243	F8-7968
44325	F8-7945
44412	F8-7648
44764	F8-7875
44987	F8-8116
45321	F8-5471
45903	F8-8131
46295	F8-8095
46557	F8-6703
47134	F8-5273
47579	F8-8069
5114	F7-9001
5290	F8-4039
5388	F8-5176
6350	F8-5011
8561	F8-5009

**LEMFÖRDER**

000190099515	G8-544
000190125515	G8-544
000190126515	G8-544
027260016581	G9-521
027290169515	G7-767
030260009581	F8-5669
030291025524	F8-5297
10001	F7-2003
1001001	F8-6456
10018	F8-4061
10021	F8-3009
1002101	F8-3009
10024	F8-4012
1002401	F8-4012
10027	F8-3000
10031	F8-5342
1003101	F8-5342
10036	F8-4028
10039	F8-1023
10048	F8-4062
1006301	F8-1028
1006401	F8-1017
10066	F8-1021
10071	F8-3002
1007201	F8-1019
10076	F8-1027
10078	F8-4066
1007901	F8-1024
1008001	G9-617
10083 01	F8-6241
1008401	F8-3052
1008501	F8-1018

**LEMFÖRDER**

10090	F8-4021
10091	F8-1022
10097	F8-4070
10098	F8-3001
10102	MK-830220
10103	MK-822920
1010301	MK-822920
10113	F8-3045
1011301	F8-3045
10118	F8-3048
10119	F8-3046
10120	F8-3047
10121	F8-3044
1012501	F8-1026
1012502	F8-1026
1012601	F8-4043
1012602	F8-4043
1012603	F8-4043
1012701	F8-3057
10128	F8-4042
10132	F8-1032
10134	F8-1031
10137	F8-1020
1017401	F8-1012
10175	F8-1013
1017501	F8-1013
10176	F8-4037
1017601	F8-4037
10177	F8-1004
10178	F8-1005
10179	F8-1003
10180	F8-1006
10181	F8-3040
10182	F8-4015
10183	F8-4014
10184 01	F8-1001
10187	F8-1025
1018701	F8-1025
10188	F8-1015
10188 01	F8-1015
10190	F8-3041
10192	F8-3054
10193	F8-1014
1019301	F8-1014
1019302	F8-1014
1019402	F8-1016
1019601	F8-1010
1019701	F8-4082
10198	F8-1034
10201	F8-4034

**LEMFÖRDER**

1020101	F8-4034
1020201	G9-541
1020301	G9-648
1020302	G9-648
10204	G9-540
1020501	F8-1007
1020501	F8-1007S
1020502	F8-1007
1020601	F8-5132
1020701	F8-4036
1020801	F8-4035
10209	F8-4032
1020901	F8-4032
10214	F8-7743
1021401	F8-7743
10215	F8-4013
10221	F8-4063
1022101	F8-4063
1022201	F8-4008
10233	F8-4075
10233	LM-10003S
10233	LM-10006S
10233 01	LM-10003S
10233 01	LM-10006S
10233 02	LM-10003S
10233 02	LM-10006S
10233 03	LM-10003S
10233 03	LM-10006S
10235	LM-10031S
10235 01	LM-10031S
10237	F8-4025
10239	F8-1009B
10240	F8-1009C
10241	F8-1002
1024101	F8-1002
1024201	F8-5738
102801	F8-7153
10313	F8-4080
1031302	F8-4080
10450	F8-5432
10453	F8-5348
10454	F8-5428
10463	F8-6491
1047501	F8-7022
10515	G9-559
1051701	G9-527
1051702	G9-527
10521	G9-638
1052901	G9-687
1053001	G9-688

**LEMFÖRDER**

1053101	G9-689
1053201	F8-5021
10546 01	F8-5069
1054602	G9-623
10551	G9-637
10551	G9-639
1055302	G9-624
10559	G9-625S
1055901	G9-625S
1055902	G9-625
1056801	F8-5506
10573	F8-5419
1057301	F8-5419
10621	F7-2039
10638	F7-2041
1063901	F8-5003
1064001	F8-5317
1064101	F8-5741
10642	F8-5771
10643 02	G7-767
10646 03	F8-7014
1064601	F8-7014
1064602	F8-7014
1064603	F8-7014
1064604	F8-7014
10662	F8-5417
10669	F8-5030
10669	F8-5417
1066901	F8-3050
1066901	F8-5417
1084201	F8-8194
10849	F8-6498
10850	F8-5004
10857	F7-2069
10859	F8-5005
10862	F8-2005
10862	F8-5449
1086202	F8-2005
1086202	F8-5449
1095901	G9-588
10960	G9-514
1096601	F8-5731
10969	F8-5502
1096901	F8-5502
1096902	F8-5502
1096903	F8-5502
1097001	F8-5009
1097101	F8-5195
10979 01	F8-6230
1098201	F8-5773



LEMFÖRDER		LEMFÖRDER		LEMFÖRDER		LEMFÖRDER	
1098301	F8-5744	11233 01	G9-652	1222002	G9-592	1305001	F8-8174
1098302	F8-5744	1128701	F8-8127	12227	G9-594	1308301	F8-6783
1098401	F8-5018	1129001	F8-7876	1222701	F8-5969	1313501	F8-5118
1098501	F8-5733	1131301	F8-6468	1222701	G9-594	1313601	F8-5117
1099002	F8-5256	1132201	F8-5477	1222702	F8-5969	1320502	F8-5746
10994	G9-544	1132301	F8-5307	1222702	G9-594	13206	F8-5311
10995	F8-5131	11346	F8-5460	1222801	G9-593	1320601	F8-5311
1099501	F8-5131	11346	F8-5461	12232	F8-4094	13208	F8-5632
1099502	F8-5131	11346 02	F8-6950	1223201	F8-4094	1320801	F8-5632
1100001	F8-4005	1134602	F8-5460	1223701	F8-4101	1320901	F8-5774
11006 01	F8-5176	1134602	F8-5461	12238	F8-4106	1322801	F8-6762
11009	F8-5613	1135501	F8-5698	12253	F8-5445	1327901	F8-6779
1100901	F8-5613	11374 01	F8-5205	12253 01	F8-5445	1327901	F8-6780
1101101	F8-5011	11537	F8-5014	1225403	F8-8145	13282	G9-658S
11013	F8-5185	11576	F8-5499	12255	F7-2059	1328201	G9-658S
1101301	F8-5185	1159001	F8-5363	1225501	F7-2059	1328202	G9-658
1101701	G9-503	1166301	G9-500	12256	F8-5444	1328601	F8-5119
11020 01	F8-5697	1167301	G9-501	12256 01	F8-5444	13292	F8-5431
1102101	F8-5678	1167301	G9-501S	12259	F8-5436	13296	F8-5171
11024	F8-4001	11674	F8-5522	12260	F8-5468	13296	LM-10011S
11028	F8-5015	1167401	F8-5522	12261	F8-5439	13296 01	LM-10011S
11029	F8-5016	11675	F8-5504	12262	F8-5462	1330601	F8-5879
11030	F8-7130	11676	LM-10004S	12266	LM-10045S	13307	F8-7353
1103001	F8-7130	11676 01	LM-10004S	12266	M-822300	13307 01	F8-7353
11032	F8-4003	11676 02	LM-10004S	12266	MK-822300	13421 01	F8-6473
11033	F8-4002	11680	G9-524	12266 01	LM-10045S	1344901	F8-5113
11038	F8-4006	1175604	F8-5076	12266 02	LM-10045S	13501 01	F8-5181
11039	F8-6235	12032 01	F8-5129	1226601	M-822300	13515	MK-822920
11044	F8-6239	1203301	F8-5718	1226601	MK-822300	1364401	F8-3004
11047 02	F8-7054	1203701	F8-5106	1226602	M-822300	1365301	F8-5777
11049	F8-3025	1203702	F8-5106	1226602	MK-822300	13660	F8-5547
11049 01	F8-3025	12040	F8-7355	12270	F8-4093	13661	F8-5546
1107801	F7-9001	1204001	F8-7355	1229201	F8-6413	13662	F8-5543
11087	F8-7103	12082	F8-5519	12296	F8-5321	13663	F8-3003
1108701	F8-7103	12084	F8-5508	12309	F8-4023	1366301	F8-3003
1108702	F8-7103	12140	F8-5499	12321	F8-5334	13664	F8-3004
1108801	F8-5582	12142	F8-5389	1232101	F8-5334	13681	F8-4065
11092	F8-5137	12143	F8-5492	1239901	F8-5198	1368101	F8-4065
11107 01	F8-5020	1214301	F8-5492	1240101	F8-5309	13684	F8-4085
1111001	F8-5732	12184	MK-820820	12422 01	F8-5323	1371301	F8-8180
11119 01	F8-6804	12190	F8-5501	12517 01	F8-6924	13714	F8-5528
11120 01	F8-6805	1219101	F8-4098	12519	F8-5007	13715	F8-5527
11123 03	F8-5327	12192	F8-4097	12519	F8-5459	13715 01	F8-5527
1112301	G9-651	1219201	F8-4097	12646	F8-5874	1376001	F8-1029
1114901	G9-667	12194	F8-5589	1265001	F8-5679	13809	F8-5427
1114902	G9-667	1219401	F8-5589	12693	G9-625S	1381801	F8-6741
1115001	F8-5010	12195	F8-3059	12834 01	F8-8101	13830	F8-5115
11171	F8-5688	12200	F8-5304	1283401	F8-8101	1383001	F8-5115
1117401	F8-5720	12219	G9-591	1287101	F8-5752	13831	F8-5114
1121902	F8-5218	1221901	G9-591	1303501	F8-6757	13842	LM-10012S

LEMFÖRDER		LEMFÖRDER		LEMFÖRDER		LEMFÖRDER	
13842 01	LM-10012S	14558 02	LM-10015S	15383	LM-10044S	1695001	F8-6763
1384401	F8-6777	14558 02	LM-10017S	15383 01	LM-10044S	16959	F8-7144
1384401	F8-6778	14563	F8-5494	15398	F8-5038	16985	F8-5887
14252	F8-5524	1456301	F8-5494	15447	F8-5430	1698501	F8-5887
1432901	F8-5146	14577	LM-10026S	15469	F8-5405	16987	F8-5839
14341	F8-3042	14577 01	LM-10026S	15540	LM-10016S	1698701	F8-5839
14342	F8-4069	14577 02	LM-10026S	15540 01	LM-10016S	1699201	F8-5689
14342	LM-10024S	14590	F8-4020	15585	LM-10046S	17350	F8-3056
14342	LM-10050S	14601	F8-7149	15585 01	LM-10046S	17355	F8-5105
14342 01	LM-10024S	1460101	F8-7149	15617	F8-5356	1735501	F8-5105
14342 01	LM-10050S	1460201	F8-7921	15622	LM-10039S	17451	F8-5251
1434501	F8-5594	14604	F8-5573	15622 01	LM-10039S	1745102	F8-5251
14354	F8-4016	1460401	F8-5573	15630	LM-10013S	17452	G9-555
14355	F8-1011	1465301	F8-5107	15630 01	LM-10013S	17452	G9-558
14358	F8-3053	14672	F8-4092	15631	LM-10001S	17463	F8-5518
14359	F8-5398	14677	F8-5438	15631	LM-10042S	17521	LM-10049S
14359 02	F8-5398	14678	F8-5437	15631 01	LM-10001S	17521 01	LM-10049S
14360	F8-3053	14679	F8-5373	15631 01	LM-10042S	17628 02	F8-6700
14360	F8-5397	14680	F8-5372	15634	LM-10002S	17629 02	F8-6704
14360 02	F8-5397	14681	F8-5371	15634 01	LM-10002S	17636	F8-3039
1436002	F8-3053	14688	F8-5418	15654	MK-850850	1763602	F8-3039
14361	F8-5346	14692	F8-5467	15655	MK-870870	17646	F8-3007
1436102	F8-5346	14698	F8-4100	15756	F8-5044	1764601	F8-3007
14362	F8-5396	14699	F8-5501	1588501	F8-7976	17650	F8-3005
1437801	F8-4033	1469903	F8-5501	15921	F8-4011	1765001	F8-3005
14389	F8-5377	1469903	F8-7973	16053	F8-5463	17655	F8-4029
14392	F8-4064	1471101	F8-5201	1605302	F8-5448	17659	G9-615
1439201	F8-4064	14721	F8-4100	1605302	F8-5463	1765901	G9-615
14393	LM-10029S	1472201	F8-5333	16056	G9-590	17661	G9-616
14393 01	LM-10029S	1472601	F8-4102	1605602	G9-590	1766101	G9-616
14404	F8-5148	14766	G9-523	16057	F8-4090	17662	F8-3050
1440401	F8-5148	14766	G9-523S	16057	F8-4094	1766201	F8-3050
14492	F8-4018	1476601	F8-5078	16057	F8-5251	17663	F8-5541
14515	MK-822920	1476601	G9-523	1605701	F8-4090	1766301	F8-5541
1452401	F8-3006	1476601	G9-523S	16058	F8-5110	17678	F8-4083
1453001	F8-5306	14775	F8-5517	1605801	F8-5110	1767801	F8-4083
1454001	F8-4044	1478401	F8-8199	1606101	F8-5911	17680	F8-7749
14541	F8-4045	14786	F8-5516	16063	F8-5337	1768001	F8-7749
1454101	F8-4045	14795	F8-5614	1611301	F8-6739	1768002	F8-7749
1455401	F7-2001	1479501	F8-5614	1611402	F8-6740	17681	F8-4039
1455501	F8-4038	14796	F8-5026	16188	F8-5441	1768101	F8-4039
1455502	F8-4038	14797	F8-5358	16193	F8-5374	17683	G9-664
1455503	F8-4038	1479801	G9-547	16193 01	F8-5374	1768301	G9-664
14556	F7-2002	14876	F8-5426	16595	F8-5672	1769701	F8-6750
1455601	F7-2002	14886	F8-5425	16596	F8-4017	17698	F8-4027
14558	F8-4072	1489201	F8-5766	1659801	F8-6748	17701	F8-5565
14558	LM-10015S	14927 01	F8-6659	1660001	F8-6749	1770101	F8-5565
14558	LM-10017S	1502401	F8-5827	1660101	F8-6751	17702	F8-5578
14558 01	LM-10015S	15026	F8-5826	16612	F8-5100	17703	F8-5575
14558 01	LM-10017S	1502601	F8-5826	1661201	F8-5100	17703 01	F8-5575





### LEMFÖRDER

17705	F8-5343
1770501	F8-5343
17779	F8-5391
17793	LM-10034S
17793 01	LM-10034S
17857	F8-5075
17857	G9-522
1785701	F8-5075
1785701	G9-522
17920	G8-544
1792001	G8-544
17923	G8-544
1792301	G8-544
17961	F8-5873
1796101	F8-5873
17978	G8-544
1797801	G8-544
1797802	G8-544
1797803	G8-544
18014	F8-5149
1801401	F8-5149
18131	F8-5500
18133	F8-5483
1885201	F8-5751
1886901	F8-8147
19129	F8-4055
1912901	F8-4055
19246	F8-5375
19247	G9-520
1924701	G9-520
19248	G9-555
1924801	F8-5968
1924801	G9-555
1924801	G9-558
19257	F8-5351
1925701	F8-5351
19282	F8-4019
19303	F8-6487
19307	F8-5352
1930701	F8-5352
19718	F8-5979
1971801	F8-5979
19908	F8-5503
1990801	F8-5503
19941	G9-633
1994101	G9-633
1994501	F8-5916
1994601	F8-5917
20018 01	F8-6935
20021	F8-5563

### LEMFÖRDER

2002101	F8-5563
20037	LM-10008S
20037	LM-10025S
20037 01	LM-10008S
20037 01	LM-10025S
20093	F8-5484
2009301	F8-5484
20094	F8-5349
20099	F8-4110
20121	F8-5762
20128	F8-5140
20128 01	F8-5140
20129	F8-5735
20130	F8-5736
20152	F8-5570
2015201	F8-7947
20155	F8-5433
2015503	F8-5433
20374	F8-5480
20375	G9-569
2037501	G9-569
20383	F8-5690
20387	G9-615
2038701	G9-615
20389	F8-5763
2038901	F8-5763
20390	F8-5683
20390 01	F8-5683
20641	F8-5019
20965	F8-5453
2096501	F8-5453
20986	F8-5007
20986	F8-5459
2099402	F8-5297
2102601	F8-5775
21027	F8-5993
21028	F8-5707
2102801	F8-5707
2106701	F8-7584
21069	F8-5798
2106901	F8-5798
21074 01	F8-6813
21079	F8-5779
21085 01	F8-6814
2110701	F8-5753
21112	F8-5996
2111201	F8-5996
21113	G9-649
21113 01	G9-649
2111301	G9-649

### LEMFÖRDER

2111302	G9-649
21114	F8-5577
2111501	F8-8179
21187	F8-5463
21215	F8-7747
2121501	F8-7747
2121502	F8-7747
21236	F8-5340
21236	F8-6076
2123601	F8-5340
2123601	F8-6076
21304	F8-5063
2130401	F8-5063
21319	F8-5692
2131901	F8-5692
21321	F8-5710
21379	F8-5318
21379 01	F8-5318
21379 02	F8-5318
21380	F8-5319
21380 01	F8-5319
21380 02	F8-5319
21381	F8-5320
2138101	F8-5320
21382	F8-5886
2138201	F8-5886
21383	F8-5322
2138301	F8-5322
21413	F8-5104
2141301	F8-5104
21419	F8-5392
2141901	F8-5392
2142101	F8-6346
2142101	F8-7100
2148601	F8-6098
2148602	F8-6098
21549	F8-5341
2154901	F8-5341
2154902	F8-5341
21603	F8-5061
21737	F8-5579
21747	F8-7352
21747	F8-7352S
2174701	F8-7352
2174701	F8-7352S
21776	F8-5108
2177602	F8-5108
21793	F8-4067
2179302	F8-4067
21794	F8-5380

### LEMFÖRDER

2179701	F8-5967
21798	F8-5593
2179801	F8-5593
21799	F8-5605
2179901	F8-5605
21800	F8-5606
2180001	F8-5606
21808	F8-5923
2180801	F8-5923
21809	F8-5617
2180901	F8-5617
21810	F8-5473
21812	F8-5620
2181201	F8-5620
21813	F8-5475
21814	F8-5474
2181401	F8-5474
2181501	F8-5801
21839	F8-3013
2183901	F8-3013
21928	LM-10020S
21928 01	LM-10020S
21928 02	LM-10020S
2193001	F8-6346
2193001	F8-7101
21937	F8-5367
21963	F8-5867
2196301	F8-5867
21997	F8-5412
2199701	F8-5412
2199801	F8-5410
22010	F8-5447
2201002	F8-5447
2201201	F8-5618
22013	F8-5514
22014	F8-5513
2201401	F8-5513
2201401	F8-5514
22015	F8-5591
2201501	F8-5591
22016	F8-5592
2201601	F8-5592
22018	F8-5599
2201801	F8-5599
22019 01	F8-5957
2201901	F8-5957
22020	F8-5515
2202001	F8-5515
22021	F8-5598
2202101	F8-5598

LEMFÖRDER		LEMFÖRDER		LEMFÖRDER		LEMFÖRDER	
2202201	F8-5858	2248001	G9-674	22747 01	LM-10001S	25248 01	F8-6656
22023	F8-5600	22483	G9-676	22747 01	LM-10042S	25291	G9-665
22025	F8-5615	2248301	G9-676	22748	LM-10009S	2529101	G9-665
2202501	F8-5615	22491	F8-5071	22748 01	LM-10009S	25320	F8-5298
22028	F8-5364	2249101	F8-5071	22751	LM-10000S	2532001	F8-5298
22036	F8-5572	2249301	F8-5810	22751 01	LM-10000S	2534601	F8-4067
2203601	F8-5572	22494	G9-604	22755	F8-5197	2534601	F8-6280
22050	F8-3008	2249401	G9-604	2275601	F8-8144	25350	G9-594
2205001	F8-3008	22496	G9-603	22845	F8-5423	2535001	F8-5969
2206301	F8-6282	2249601	G9-603	22884	F8-5424	2535001	G9-594
2206301	F8-7096	22498	G9-525	23565	F8-3060	25351	F8-5334
22068	F8-5325	2249801	G9-525	2356501	F8-3060	2535101	F8-5334
2206801	F8-5325	22499	F8-5806	23711	F8-5228	25352 01	F8-1008
22095	F8-5866	2249901	F8-5806	2371101	F8-5228	25369	F8-7748
2209501	F8-5866	22500	F8-5630	24502	G9-677	2536901	F8-7748
22116	F8-5109	2250001	F8-5630	2450201	G9-677	25372	F8-5370
2211601	F8-5109	22501	F8-5835	24512	G9-556	2537501	F8-8142
22117	F8-3024	22502	F8-5836	2451201	G9-556	25376	F8-5368
22118	F8-5409	2250201	F8-5836	24515	F8-6143	2537601	F8-5368
2211801	F8-5409	22503	F8-5837	2451501	F8-6143	25396	F8-8071
22120	F8-5505	2250301	F8-5837	24516	G9-571	2539601	F8-8071
2212001	F8-5505	22505	F8-5829	24518 01	F8-6802	25397	F8-6835
2212001	F8-6313	22506	F8-5830	24548	G9-585	2540101	F8-8175
22121	F8-5406	2250601	F8-5830	2454801	G9-585	2540601	F8-5007
2212101	F8-5406	22509	F8-5799	24610	F8-3026	25407 01	F8-6647
22123	F8-5607	2250901	F8-5799	24636 02	F8-6529	2540901	F8-6539
2212301	F8-5607	22513	F8-5271	2463601	F8-6529	25413	F8-5929
22134	F8-5930	2251301	F8-5271	2477401	F8-7700	2541301	F8-5929
2213401	F8-5930	22613	F8-6013	24775	F8-6087	2543201	F8-6761
22149	AK-735006	2261301	F8-6013	2477501	F8-6087	2543302	F8-6760
22161	F8-4066	22615 01	F8-6064	24812	F8-5963	25443	F8-6100
2216101	F8-4066	22616	F8-6060	2481201	F8-5963	2544301	F8-6100
2218001	F8-6004	2261601	F8-6060	24913 01	F8-6811	2572401	F8-6283
2221401	F8-6231	2261701	F8-6061	2491401	F8-8128	2572401	F8-7097
22304	F8-5064	22620	F8-5365	24915 01	F8-6812	2580301	F8-7149
2230401	F8-5064	2262001	F8-5365	24930	F8-5669	25813	G9-634
22387	LM-10005S	2262101	F8-6755	2493001	F8-5669	2581301	G9-634
22387 01	LM-10005S	2262301	F8-8155	24956	F8-5422	2585201	F8-6085
22392	F8-5496	22625	F8-5404	2506101	F8-8154	25854 01	F8-6583
2239201	F8-5496	2262501	F8-5404	25150	F8-5353	2585901	F8-7451
22419	F8-5901	22626	F8-5390	25150 01	F8-5353	2586401	F8-7599
2241901	F8-5901	2262601	F8-5390	2515001	F8-8067	2586502	F8-7971
22423	F8-5326	22627	F8-5388	25151	F8-5354	2586601	F8-8012
2242301	F8-5326	22629	F8-5386	2515101	F8-5354	25867	F8-5574
22458	F8-5308	22630	F8-5387	2515101	F8-8066	25867 01	F8-5574
22477	G9-570	22631	F8-5385	25176	G9-586	25879	F8-6499
2247701	G9-570	22633 01	F8-6217	2517601	G9-586	25879 01	F8-6499
22479	F8-5111	2263701	F8-8126	25216	G9-675	25880	F8-7879
2247901	F8-5111	22747	LM-10001S	2521601	G9-675	25880 01	F8-7879
22480	G9-674	22747	LM-10042S	25247 01	F8-6699	2588101	F8-7924



### LEMFÖRDER

2588701	F8-8181
2588901	F8-6758
2590601	F8-6084
25907	F8-5576
25907 01	F8-5576
25909	F8-5542
2590901	F8-5542
25916 01	F8-6471
25917 01	F8-6470
25927 01	F8-8230
25931	F8-4037
2593101	F8-4037
2594701	F8-6431
2594801	F8-6430
2594901	F8-6352
25950	F8-6151
2595001	F8-6151
2597801	F8-6368
25993	F8-5136
2599301	F8-5136
25996	F8-5242
2599601	F8-5242
25997	F8-5249
2599701	F8-5249
25999	F8-5062
2599901	F8-5062
26030	F8-7850
2603001	F8-7850
2603201	F8-5834
2603501	F8-8183
2604001	F8-8195
2604201	F8-6112
2604401	F8-6113
26054	F8-6164
26054 01	F8-6164
26055	F8-6066
2605501	F8-6066
26069	F8-5447
26070	F8-5865
2607001	F8-5865
2607101	F8-6198
26082 01	F8-6968
26082 01	F8-6969
26084 01	F8-6951
26085	F8-5545
2608501	F8-5545
2608901	F8-6059
26091	F8-5530
2609101	F8-5530
26092	F8-5027

### LEMFÖRDER

2609201	F8-5027
26096	F8-4099
2609601	F8-4099
26102.01	F8-6722
2610301	F8-7940
26563	F8-5077
2656301	F8-5077
26571	F8-6129
2657101	F8-6129
26574	F8-6135
2657401	F8-6135
26577	F8-5213
2657701	F8-5213
26578	F8-5871
2657801	F8-5871
26579	F8-5970
2657901	F8-5970
26580	F8-5262
2658001	F8-5262
2658901	F8-6243
2659001	F8-6547
2659301	F8-6057
26597 01	F8-8094
2659701	F8-8094
26600	F8-6166
2660001	F8-6166
26602	F8-5821
2660201	F8-5821
26603	F8-5778
26605	F8-6015
2660501	F8-6015
2660601	F8-6775
26609	F8-5329
26609	F8-5971
2660901	F8-5329
2660901	F8-5971
26614	F8-6136
26614 01	F8-6136
2662301	F8-8133
26624	F8-5458
2662401	F8-5458
26642	F8-1034S
2664201	F8-1034S
26665	F8-5537
2666501	F8-5537
2678201	F8-6447
2678301	F8-7329
2681401	F8-7928
26815	F8-7694
2681501	F8-7694

### LEMFÖRDER

2681601	F8-7471
2682001	F8-7938
26923 01	F8-6467
2693401	F8-6351
26935	F8-7745
2693501	F8-7745
26936	F8-5302
2693601	F8-5302
26937	F8-5303
26937 01	F8-5303
2693801	F8-7988
2696001	F8-7327
27001	F8-5433
2700101	F8-5433
27067	F8-6531
27067 01	F8-6531
27068	F8-6989
27068 01	F8-6989
27069 01	F8-6988
2707001	F8-7958
2707101	F8-6528
27072	F8-5380
2707201	F8-5380
27077	F8-7796
2707701	F8-7796
2709301	F8-6040
2710801	F8-6774
2711901	F8-6080
2712201	F8-6782
27126	F8-6784
2712601	F8-6784
27132	F8-6464
2713201	F8-6464
27134	F8-7447
2713401	F8-7447
27135	F8-7448
2713501	F8-7448
27148	F8-7795
2714801	F8-7795
2717001	F8-6251
2718201	F8-6767
2718301	F8-6764
27184 01	F8-6570
2718501	F8-6828
2718601	F8-6829
2718701	F8-7832
2718801	F8-7579
2718901	F8-6352
2719101	F8-5311
27199	F8-5450

### LEMFÖRDER

2719901	F8-5450
27217 01	F8-6112
2730601	F8-7909
27308	G9-663
2730801	G9-663
27309	F8-5506
2730901	F8-5506
2731001	F8-6781
27408	G9-662
2740801	G9-662
2743601	F8-5231
27437	F8-5670
27438	F8-4057
2743801	F8-4057
2743901	F8-5846
27451	F8-6181
2745101	F8-6181
27461	F8-5395
2746101	F8-5395
27605 01	F8-6992
2760801	F8-8137
27627	F8-5340
2762701	F8-5340
2762701	F8-6076
2768001	F8-1010S
27681	F8-4008
27681 01	F8-4008
2768101	F8-4008S
27682 01	F8-1016S
2768201	F8-1016
27705	F8-7695
27705	F8-7695S
2770501	F8-7695
2770501	F8-7695S
27706	F8-7696
27706	F8-7696S
2770601	F8-7696
2770601	F8-7696S
2772201	F8-7990
2772301	F8-6549
2773301	F8-6100
27750 01	F8-7028
27760 01	F8-6651
27869	F8-6074
2786901	F8-6074
27924	F8-5248
2792401	F8-5248
2797201	F8-6058
27998 01	F8-6981
2822801	F8-6540



LEMFÖRDER		LEMFÖRDER		LEMFÖRDER		LEMFÖRDER	
2825401	F8-6349	2937501	F8-5099	29813	F8-7145	299401205617	F8-4070
2825401	F8-6350	29376	F8-5150	2981301	F8-7145	299401394617	F8-4071
2872901	F8-6652	2937601	F8-5150	29821	F8-6252	299405135576	MK-822300
28744 01	F8-6652	29377	G9-698	2982101	F8-6252	299405831617	F8-4069
28759	F8-5915	2937701	G9-698	2982301	F8-6943	29961 01	F8-6961
28759_01	F8-5915	29410	F8-6523	2982701	F8-8201	29962 01	F8-6892
2875901	F8-6385	2941001	F8-6523	2984701	F8-8190	2996301	F8-7972
28764	F8-5622	29411 01	F8-6662	299000017617	F8-4074	2996701	F8-7922
2876401	F8-5622	29470	F8-4109	299000029617	F8-4075	2997801	F8-7951
28765	F8-5621	2947001	F8-4109	2990001	F8-6348	2997801	F8-8164
2876501	F8-5621	29471	F8-6502	299001932524	F8-5176	2997901	F8-8173
2887601	F8-7455	2947401	F8-6357	299010080504	G9-617	29981 01	F8-7049
2887701	F8-7431	29487	F8-5016	299010091504	F8-1022	29982	F8-7032
2887801	F8-7992	2949001	F8-5327	299010125504	F8-1026	29982 01	F8-7032
2887901	F8-7989	29511	F8-5490	299010126504	F8-1026	29991	F8-5123
28880	F8-6488	29512	F8-5482	299010127504	F8-3057	29993 01	F8-7033
2888601	F8-6333	2951201	F8-5482	299010174617	F8-1012	30110	LM-10014S
2888701	F8-7157	29513	F8-6483	299010175617	F8-1013	30110 01	LM-10014S
2889301	F8-7993	29514	F8-5087	299010176617	F8-1012	30111	F8-4075
28894	F8-6196	29514 01	F8-5087	299010202617	G9-541	30111	LM-10003S
2889401	F8-6196	29514 02	F8-5087	299010204617	G9-540	30111	LM-10006S
2889601	F8-7912	29516	F8-5253	299010515515	G9-559	30111 01	LM-10003S
2889701	F8-7974	2951601	F8-5253	299010521515	G9-637	30111 01	LM-10006S
28898	F8-6134	29518	F8-6079	299010521515	G9-638	3011101	F8-4075
2889801	F8-6134	2951801	F8-6079	299010522515	G9-559	30112	F8-4069
28899	G9-699	29529	F8-5629	299010546515	G9-637	30112	LM-10024S
2889901	G9-699	2952901	F8-5629	299010553515	G9-637	30112	LM-10050S
29318	F8-7796	2953001	F8-6535	299010559515	G9-625	30112 01	LM-10024S
2931801	F8-7796	2953001	F8-6537	299010559515	G9-625S	30112 01	LM-10050S
2931901	F8-6737	29543	F8-5245	299010639515	F8-5003	3011201	F8-4069
2932001	F8-6738	2954701	F8-7741	299010959524	G9-588	30114	LM-10004S
29323	F8-5994	2955201	F8-7158	299010960524	G9-514	30114 01	LM-10004S
2932901	F8-7630	2955301	F8-6367	299010994524	G9-544	30115	LM-10045S
29339	F8-5951	29578	F8-6421	299011078524	F7-9001	30115	M-822300
2933901	F8-5951	29635	G9-653	299011663536	G9-500	30115	MK-822300
2934201	F8-7361	2963501	G9-653	299011673536	G9-524	30115 01	LM-10045S
2934301	F8-7362	29694 01	F8-6994	299011680536	G9-524	3011501	M-822300
2934801	F8-7370	2969601	F8-8148	299012220576	G9-592	3011501	MK-822300
2935001	F8-7463	2970101	F8-8156	299019247581	G9-520	3012001	F8-4070
2935401	F8-7473	2970801	F8-6580	299021113504	G9-649	30121	F8-4071
2935601	F8-7472	29709	F8-7873	29916	F8-5633	30121	LM-10031S
29362	F8-7438	29709 01	F8-7873	2991601	F8-5633	30121 01	LM-10031S
2936201	F8-7438	29727 01	F8-8129	2991701	F8-7902	3012101	F8-4071
2936501	F8-5945	2975001	F8-8130	2991801	F8-7907	30123	LM-10011S
2936601	F8-5950	2975101	F8-6145	2991901	F8-7908	30123 01	LM-10011S
2936901	F8-7366	29779	F8-6250	29920 01	F8-6463	3012301	F8-5171
2937001	F8-7367	29779 01	F8-6250	299217115617	F8-4073	30124	LM-10012S
29374	F8-5066	2979301	F8-7697	299217163617	F8-4076	30124 01	LM-10012S
2937401	F8-5066	29794	F8-6638	29931	F8-7797	30126	F8-4076
29375	F8-5099	2979401	F8-6638	2993101	F8-7797	30126	LM-10029S



### LEMFÖRDER

30126 01	LM-10029S
3012601	F8-4076
30127	LM-10015S
30127	LM-10017S
30127 01	LM-10015S
30127 01	LM-10017S
3012701	F8-4072
30128	F8-4073
30128	LM-10026S
30128 01	LM-10026S
3012801	F8-4073
30136	LM-10044S
30136 01	LM-10044S
3013701	F8-5038
30144	LM-10016S
30144 01	LM-10016S
30147	LM-10046S
30147 01	LM-10046S
30149	LM-10039S
30149 01	LM-10039S
30152	LM-10001S
30152	LM-10042S
30152 01	LM-10001S
30152 01	LM-10042S
30154	LM-10002S
30154 01	LM-10002S
30158	F8-5044
3015801	F8-5044
30162	LM-10034S
30162 01	LM-10034S
3016401	LM-10072S
30171	LM-10008S
30171	LM-10025S
30171 01	LM-10008S
30171 01	LM-10025S
3017501	LM-10063S
3017601	F8-5061
30177	F8-4074
30177	LM-10020S
30177 01	LM-10020S
30177 02	LM-10020S
3017702	F8-4074
30178	LM-10005S
30178 01	LM-10005S
30179	LM-10001S
30179	LM-10042S
30179 01	LM-10001S
30179 01	LM-10042S
30180	LM-10009S
30180 01	LM-10009S

### LEMFÖRDER

30183	LM-10000S
30183 01	LM-10000S
30189	LM-10019S
30189 01	LM-10019S
30192	LM-10023S
30192 01	LM-10023S
3019401	LM-10059S
30195	LM-10030S
30195 01	LM-10030S
30196	LM-10048S
30196 01	LM-10048S
30197	LM-10047S
30197 01	LM-10047S
30201	LM-10028S
30201 01	LM-10028S
30202	LM-10036S
30202 01	LM-10036S
3020701	LM-10058S
30208	LM-10010S
30208 01	LM-10010S
30209	LM-10040S
30209 01	LM-10040S
30212	LM-10032S
30212 01	LM-10032S
30217	LM-10007S
30217 01	LM-10007S
30243	LM-10033S
30243 01	LM-10033S
3033901	F8-6166
30346 01	F8-6724
3034602	F8-6724
30355	F8-5933
3035601	F8-6337
3036301	F8-7359
3036401	F8-7932
30436	F8-7377
3043601	F8-7377
30439 01	F8-6980
30443 01	F8-6975
3044501	F8-8170
3046001	F8-5106
3046001	F8-5254
30498	F8-6014
30498_01	F8-6014
3049801	F8-6384
30507 01	F8-6823
30508 01	F8-7026
30509 01	F8-6824
30510 01	F8-6830
3052501	F8-8192

### LEMFÖRDER

3052601	F8-8185
3052701	F8-8193
3052901	F8-8203
30535	F8-7048
30535 01	F8-7048
3053701	F8-6662
30538 01	F8-6532
30539	F8-5551
3053901	F8-5551
3054001	F8-6752
30541	F8-5535
3054101	F8-5535
3054201	F8-7952
30543 02	F8-6945
3054401	F8-6347
3054501	F8-6946
3054601	F8-6947
3054701	F8-6948
3054801	F8-7454
30582 01	F8-6476
30608	G9-549
3060801	G9-549
30716 01	F8-6991
30718 01	F8-6988
30719	F8-6989
30719 01	F8-6989
30721 01	F8-6673
30722 01	F8-6674
30723 01	F8-8117
3072301	F8-8117
30724	F8-6707
3072401	F8-6707
30726 01	F8-8227
3075701	F8-6776
30758 01	F8-6718
30771 01	F8-6696
3083601	F8-6112
3089001	F8-7603
30891 01	F8-6706
30923	LM-10008S
30923	LM-10025S
30923 01	LM-10008S
30923 01	LM-10025S
30982 01	F8-7056
3098201	F8-7056
31014	F8-7038
3101401	F8-7038
3101501	F8-6286
3101601	F8-6288
3101701	F8-7418

### LEMFÖRDER

3101801	F8-6515
3101901	F8-6472
3102401	F8-8166
31026	F8-6482
3102601	F8-6482
31027	F8-6505
31029 01	F8-6993
31030 01	F8-6882
3103201	F8-6358
31034 01	F8-6990
31035 01	F8-6968
31036 01	F8-6969
3104001	F8-7605
3104201	F8-6353
31084 01	F8-6475
3108501	F8-8165
3108601	F8-3050
3109201	F8-5416
3112101	F8-6369
3112501	F8-7462
3112601	F8-7462
31154 01	F8-7001
3115401	F8-7001
3117401	F8-6302
31188 01	F8-6098
3118801	F8-6098
31203 01	F8-7002
3120301	F8-7002
3120401	F8-6998
3122001	F8-8153
3124201	F8-7977
3125201	F8-7464
3125401	F8-7369
3125801	F8-7474
3126001	F8-3023
31261 01	F8-6611
3126201	F8-7468
31263 01	F8-6610
3126401	F8-7467
3127001	F8-8150
3127501	F8-8191
31285 01	F8-6597
3131401	F8-6289
3134301	F8-5537
31345 01	F8-6596
3137201	F8-5501S
3137401	F8-5304S
31381 01	F8-6885
31382 01	F8-6912
31385 01	F8-7020

LEMFÖRDER		LEMFÖRDER		LEMFÖRDER		LEMFÖRDER	
3138701	F8-5603	3150501	F8-7328	33596	LM-10046S	34054 01	F8-6732
3139201	F8-6307	3176401	F8-6569	33596 01	LM-10046S	34055 01	F8-5330
3139601	F8-5447S	3177001	F8-6284	3359901	F8-7148	3405801	F8-8031
3139701	F8-6262	3177101	F8-6281	3360401	F8-7148	34061	F8-7827
3139801	F8-6308	31923	F8-7038	33606	LM-10038S	3406101	F8-7827
3140001	F8-5413	3192301	F8-7038	33606 01	LM-10038S	34065	F8-7826
3140201	F8-6312	31924 01	F8-7040	33615	LM-10100S	3406501	F8-7826
31406 01	F8-6379	3192401	F8-7040	33615 01	LM-10100S	34081 01	F8-6730
3140601	F8-6379	31935 01	F8-6598	33714	F8-7667	34094 01	F8-5723
3140701	F8-3032	3194401	F8-7330	3371401	F8-7667	3434301	F8-7604
3140901	F8-3017	31991 01	F8-6670	33715	F8-7668	3434401	F8-7995
3141001	F8-6381	3199901	F8-7910	3371501	F8-7668	34350	F8-7721S
3141101	F8-5962	3200001	F8-7911	33716	F8-7665	3435001	F8-7721S
3141201	F8-6380	3200201	F8-8087	3371601	F8-7665	34370	F8-7671
3141601	F8-6292	3200401	F8-6587	33717	F8-7666	3437001	F8-7671
3141901	F8-3014	3314101	F8-7960	3371701	F8-7666	34377	F8-6714
3142001	F8-3012	3314301	F8-7961	33718	F8-7669	3437701	F8-6714
3142201	F8-6479	33144 01	F8-7962	3371801	F8-7669	3437901	F8-7959
3143001	F8-7164	3314501	F8-8152	33719	F8-7670	34420 01	F8-6505
3143501	F8-5948	3314701	F8-7981	3371901	F8-7670	3444601	F8-7427
31443 01	F8-6861	33152 01	F8-6923	3372001	F8-6996	3445301	F8-7435
31444 01	F8-6873	3315301	F8-8198	33721 01	F8-6644	34462 01	F8-6617
3144501	F8-8188	3324201	F8-6995	33722 01	F8-6645	3450401	F8-5149
3145101	F8-6291	33246 01	F8-7037	33723 01	F8-6646	3455001	F8-6510
3145301	F8-6329	3324601	F8-7037	3373501	F8-7421	34559 01	F8-6736
3145601	F8-6026	33247 01	F8-7034	33754 01	F8-8115	3456901	F8-8169
3145801	F8-6294	3324701	F8-7034	3375401	F8-8115	3457101	F8-6601
3146001	F8-6297	33248	F8-7038	3375701	F8-8177	3457501	F8-8172
3146101	F8-6296	3324801	F8-7038	33758 01	F8-6637	3457701	F8-8146
3146401	F8-6299	3325001	F8-8163	33799	F8-7794	3457901	F8-5408
3146501	F8-7163	33251 01	F8-6720	3379901	F8-7794	3458001	F8-7102
3146601	F8-6293	33252 01	F8-6721	33800	F8-7793	3468201	F8-6317
31469 01	F8-6267	33267 01	F8-6144	3380001	F8-7793	34695 01	F8-5210
31474 01	F8-6871	33268 01	F8-6648	3380101	F8-8161	3469901	F8-6517
3147701	F8-7465	3329201	F8-7477	3380201	F8-8158	3470001	F8-8085
3147801	F8-7466	3338801	F8-6514	33807	F8-6692	34711	F8-6701
3148401	F8-6511	33389 01	F8-8215	3380701	F8-6692	3471101	F8-6701
31486 01	F8-3027	33413 01	F8-8078	33808	F8-6693	34715 01	F8-5532
3148801	F8-6196	3341301	F8-8078	3380801	F8-6693	3471501	F8-7954
3149001	F8-6195	3341701	F8-7837	3381201	F8-8200	3471701	F8-7923
3149201	F8-6290	3346401	F8-6100	3383801	F8-7423	3474801	F8-5550
3149301	F8-6264	3346601	F8-6768	3383901	F8-7424	34749 01	F8-6694
3149501	F8-7371	3350301	F8-7631	33876	F8-7747	3475601	F8-5297
3149701	F8-6177	3350401	F8-7478	3387601	F8-7747	34762 01	F8-6425
31498 01	F8-6525	3351201	F8-5300	3394601	F8-7494	3476301	F8-6424
3149801	F8-7057	33592	LM-10025S	3394701	F8-7575	3479501	F8-7966
3149901	F8-6338	33592 01	LM-10008S	34002	F8-6210	34907	F8-7742
3150001	F8-6354	33592 01	LM-10025S	34052 01	F8-5220	3490701	F8-7742
3150101	F8-7169	33594	LM-10022S	34053	F8-5221	3490901	F8-7626
3150401	F8-7172	33594 01	LM-10022S	34053 01	F8-5221	34923	LM-10021S



### LEMFÖRDER

34923 01	LM-10021S
3498501	F8-7492
3499001	F8-7440
3501901	F8-7429
3502001	F8-7428
3502201	F8-7628
3502501	F8-7983
3502701	F8-7968
3502801	F8-6167
35033 01	F8-6705
3503401	F8-7875
35056	F8-7739
3505601	F8-7739
3526901	F8-5380
35278 01	F8-6469
3531201	F8-7616
3531601	F8-7997
3532001	F8-6357
3532101	G9-568
3532201	G9-567
3532501	F8-5248
3532601	F8-5355
35330	F8-7797
3533001	F8-7797
3536301	F8-4090
3536301	F8-4094
35377 01	F8-6729
3538001	F8-7941
35381 01	F8-6582
3538901	F8-8002
3539401	F8-8140
35400	F8-7858
3540001	F8-7858
3541901	F8-7723
3542001	F8-7724
3544601	F8-7967
35452	F8-7740
3545201	F8-7740
3545401	F8-7432
3545501	F8-7434
3547701	F8-7433
3548001	F8-7999
3548101	F8-5227
3550101	F8-6518
3550201	F8-7456
35519	F8-7851
3551901	F8-7851
35543	F8-7878
35543 01	F8-7878
35544	F8-7877

### LEMFÖRDER

35544 01	F8-7877
35545 01	F8-8069
3554501	F8-8069
3555301	F8-7984
35725	F8-7856
3572501	F8-7856
3575301	F8-7624
3576201	F8-7965
35852 01	F8-5382
3588601	F8-6462
3588701	F8-6461
3588801	F8-6460
3593301	F8-7901
3593401	F8-5215
3593601	F8-7944
35937 01	F8-7914
35953	F8-8074
35953 01	F8-8074
3595301	F8-8074
35954	F8-8075
35954 01	F8-8075
3595401	F8-8075
36000	F8-6719
36000 01	F8-6719
36019	LM-10041S
36019 01	LM-10041S
3618001	F8-7476
3623901	F8-5130
3626801	F8-6795
3626901	F8-6115
3626901	F8-6452
3627001	F8-5090
3627101	F8-6114
3627401	F8-8151
3627701	F8-5098
3627801	F8-6034
3627901	F8-6796
36280	F8-7746
3628001	F8-7746
3628201	F8-5490
3628301	F8-5328
3628401	F8-8162
3628501	F8-6171
3628601	F8-6172
3628801	F8-8141
3628901	F8-6788
3629001	F8-6639
3629201	F8-6773
3629401	F8-5085
3630001	F8-6135

### LEMFÖRDER

3630001	F8-6135S
3632401	F8-7956
3637701	G9-687
36426	F8-6250
36426 01	F8-6250
36459 01	F8-8093
3645901	F8-8093
3646001	F8-5099
3646501	G9-549
3647701	F8-5480
3648601	F8-8167
3649401	F8-8184
3649601	F8-6221
3649701	F8-6130
3649801	F8-6131
3649901	F8-5092
3650001	F8-7942
3650101	F8-6129
3650301	F8-5312
3650401	F8-5098
3652201	F8-1012
3652701	F8-6661
3653201	F8-6774
3666101	F8-8131
3668801	F8-6151
3676101	F8-6580
3683101	F8-6638
36954 01	F8-8092
3695401	F8-8092
3700101	G7-1001
3702001	F8-7881
3702101	F8-7882
3702201	F8-5303
3702301	F8-7883
3706701	F8-7798
37070 01	F8-8106
3707001	F8-8106
37071 01	F8-8105
3707101	F8-8105
3708401	F8-8178
3715301	F8-1017
3745001	F8-7989
3765101	F8-7992
3768801	F8-7946
3772101	F8-7161
3772701	F8-8196
3774101	F8-6017
3774201	F8-7162
3774401	F8-5378
3780701	F8-6724

### LEMFÖRDER

3792701	F8-5301
3794301	F8-6679
3795001	F8-8168
515242044	G9-625S
515448752	F8-5311
581000141	G9-523
581000141	G9-523S
616466104	F8-7355
617000148	F8-7743
734178131993	F8-1022
734178132007	F8-1031
735900132011	F8-1020
735900132012	F8-1021

### MEYLE

014 024 0026	F8-6924
014 024 0070	F8-6426
014 024 0074	F8-6427
014 024 0084	F8-6647
014 024 0088	F8-6951
014 024 0089	F8-6950
014 024 0091	F8-6644
014 024 0092	F8-6645
014 024 0093	F8-6646
014 032 0000	F8-5770
014 032 0020	F8-5210
014 032 0052	F8-5751
014 032 0076	F8-6466
014 032 0084	F8-5113
014 032 0099	F8-5811
014 032 0120	F8-5219
014 032 0122	F8-5217
014 032 0123	F8-5218
014 032 0205	F8-5209
014 032 0208	F8-5980
014 032 0301	F8-5227
014 032 0506	F8-5779
014 033 0021	F8-6474
014 033 0049	F8-5307
014 033 0086/HD	F8-6813
014 033 0086/HD	F8-6814
014 033 0091	F8-6113
014 033 0114	F8-6473
014 033 0157	F8-6112
014 033 0159	F8-6135
014 035 0002	F8-4005
014 035 0003	F8-5731
014 035 0004	F8-5739
014 035 0007	F8-5732
014 035 0009	F8-5773
014 035 0010	F8-5744



MEYLE		MEYLE		MEYLE		MEYLE	
014 035 0018	G9-651	0140320001/HD	F8-5502	0140410037	F8-5016	0340410003	F8-5014
014 035 0035	F8-5697	0140320019	F8-5137	0140410043	F8-4002	0341300001	F8-8144
014 035 0046	F8-5679	0140320021	F8-6539	0140410045	F8-4001	100 030 0002	F8-6212
014 035 0073/HD	F8-6230	0140320024	F8-5236	0140410045/S	F8-4001	100 053 0005	F8-5654
014 035 0084	F8-6161	0140320037/HD	F8-5613	0140419042/S	F8-4006	100 053 0006	F8-6392
014 035 0085	F8-6145	0140320039	F8-5914	0140419043/S	F8-4002	100 053 0007	F8-6391
014 035 0089	F8-6182	0140320062	F8-5149	0140419044/S	F8-4003	100 053 0008	F8-5650
014 035 0089	F8-6648	0140320078	F8-5901	0140460001	F7-9001	100 105 0008	F8-5202
014 035 0097	F8-6184	0140320092	AK-735019	0140460006	F8-5582	100 121 1071	F8-5554
014 035 0102	F8-6119	0140320101	F8-5834	0140460150	F8-5181	100 130 0004	F8-5532
014 035 0103	F8-6120	0140320102	F8-5918	0140469017	F8-7103	100 130 0013	F8-6470
014 035 0105	F8-6181	0140320107S	F8-5236	0140580002	F8-5020	100 153 0004	F8-5649
014 041 0036	F8-6239	0140320121	F8-5214	0141520015	F8-7130	100 199 0022	F8-1031
014 041 0040	F8-7054	0140320217	F8-6514	0141520048	F8-6760	100 199 0023	F8-1032
014 058 0005	F8-5730	0140321003	F8-6059	0141520050	F8-7721S	100 199 0043	F8-6922
014 152 0002	F8-6235	0140321037/HD	F8-5613	0141520059	F8-7720S	100 199 0052	F8-6925
014 610 0000	F8-6468	0140330004	F8-5009	0141520061	F8-6761	100 199 0054	F8-5685
014 610 0001	F8-6467	0140330004	F8-5195	0146100007	F8-7377	100 199 0063	F8-5907
014 610 0003	F8-6651	0140330012	F8-5178	0146100017/HD	F8-8116	100 199 0064	F8-6923
014 610 0015	F8-6730	0140330013	F8-5011	0146100017HD	F8-8116	100 199 0066	F8-4019
014 615 0002	F8-5231	0140330014	F8-5185	0146150001	F8-5229	100 199 0067	F8-5934
014 620 0002	LM-10082S	0140330015	F8-5176	0146400006	AK-735223	100 199 0069	F8-5385
014 640 0002	AK-735418	0140330015/HD	F8-5176	0146410001	F8-5962	100 199 0083	F8-6892
014 640 0003	AK-735081	0140330016/HD	F8-5023	0160106313	F8-5297	100 199 0084	F8-6961
014 640 0007	AK-735222	0140330017	G9-588	0266410000	F8-7630	100 199 0085	F8-6425
014 641 0000	F8-6518	0140330019	G9-514	034 024 0028	F8-6465	100 199 0086	F8-6424
014 710 0010	F8-6641	0140330034	F8-6652	034 032 0001	F8-5205	100 199 0092	F8-6241
014 710 0011	F8-6640	0140330054	F8-5131	034 032 0008	F8-5750	100 199 0096	F8-7962
0140228500	G9-544	0140330061/HD	F8-5198	034 032 0016	F8-5704	100 199 0115	F8-5551
0140240006	F7-2069	0140330085	F8-5010	034 032 0018	F8-5705	100 199 0119	F8-5534
0140240032	F8-8194	0140330085	G9-667	034 032 0044	F8-6704	100 199 0123	F8-6742
0140240053	F8-5460	0140330148	F8-7932	034 032 0045	F8-5788	100 199 0128	F8-6532
0140240056	F8-5007	0140330159	F8-6135S	034 032 0046	F8-6231	100 199 0134	F8-6530
0140240056	F8-5458	0140330200	G9-544	034 032 0047	F8-6380	100 199 0135	F8-6758
0140240056	F8-5459	0140350001HD	F8-5733	034 032 0049	F8-5752	100 199 0140	F8-7599
0140240057	F8-8178	0140350011	F8-5018	034 032 0064	F8-6017	100 199 0141	F8-6990
0140240061	F8-8203	0140350011HD	F8-5018	034 032 0066	F8-5769	100 399 0002	F8-1022
0140240063	F8-8126	0140350014	F8-5327	034 032 0067	F8-5846	100 399 0007	F8-3002
0140240064	F8-8192	0140350015	F8-5018	034 032 0093	F8-5453	100 399 0021	F8-5544
0140240065	F8-8154	0140350026	F8-5917	034 033 0004	F8-6529	100 399 0024	F8-7047
0140240066	F8-8185	0140350027	F8-5827	034 035 0035	F8-6057	100 399 0028	F8-5575
0140240078	F8-8175	0140350038	F8-5767	034 041 0027	F8-6240	100 407 0025	F8-5471
0140240079	F8-8153	0140350043	F8-5678	034 046 0015	LM-10056S	100 407 0085	F8-6699
0140240080	F8-7747	0140350044	F8-5873	034 710 0001	F8-5019	100 411 0011	F8-5081
0140240085	F8-8193	0140350045	F8-5874	0340240033	F8-8147	100 411 0014	F8-4052
0140240157	F8-6950	0140350106	F8-6144	0340320007	F8-8101	100 411 0017	F8-5225
0140249047	F8-5004	0140356301	G9-503	0340320047	F8-5967	100 411 0026	F8-5064
0140249052	F8-5461	0140410019	F8-5015	0340320053	F8-5261	100 411 0030	F8-4055
0140249053	F8-5460	0140410024	F8-6235	0340320065	F8-7920	100 411 0041	F8-6190
0140320001	F8-5502	0140410037	F8-5015	0340320092	F8-5378	100 411 0044	F8-5382





MEYLE		MEYLE		MEYLE		MEYLE	
100 411 0049	F8-6694	100 640 0011	AK-735025	1001990035	F8-1025	1001990152	F8-7964
100 411 0050	F8-6462	100 641 0003	F8-6569	1001990036	F8-3053	1001990161	F8-7981
100 411 0051	F8-6461	100 642 0008	F8-7577	1001990036	F8-5396	1001990162	F8-7982
100 411 0052	F8-6460	100 643 0003	F8-7132	1001990036	F8-5397	1001990178	F8-7956
100 411 0053	F8-6579	100 710 0009	F8-7046	1001990037	F8-1011	1001990180	F8-8171
100 412 0007	F8-7453	100 740 0000	F8-5905	1001990038	F8-5400	1001990217	F8-7959
100 412 0008	F8-5738	100 740 0001	F8-5904	1001990039	F8-5546	1002510000	F8-4023
100 412 0009	F8-5360	100 740 0003	AK-735040	1001990040	F8-5565	1003990001	F8-4028
100 412 0015	F8-5993	100 740 0005	AK-735028	1001990041	F8-5404	1003990006	F8-4030
100 412 0021	F8-5550	100 740 0006	AK-735029	1001990044	F8-5579	1003990008	F8-4031
100 412 0022	F8-5580	100 740 0007	AK-735127	1001990045	F8-5383	1003990009	F8-5576
100 412 0030	F8-6039	100 740 0009	AK-735181	1001990046	F8-5529	1003990010	F8-3003
100 412 0032	F8-5995	100 740 0017	AK-732516	1001990047	F8-1020	1003990010	F8-3004
100 412 0039	F8-6570	100 740 0018	AK-735014	1001990048	F8-5538	1003990011	F8-3003
100 419 0006	LM-10026S	100 741 0001	F8-6351	1001990050	F8-4021	1003990012	F8-5543
100 419 0010	LM-10024S	100 742 0001	F8-4086	1001990051	F8-5545	1003990013	F8-5578
100 419 0011	LM-10031S	100 742 0007	F8-6006	1001990053	F8-5386	1003990015	F8-5577
100 419 0015	LM-10088S	100 742 0008	F8-7579	1001990055	F8-5527	1003990022	F8-4029
100 419 0017	LM-10021S	100 742 0013	F8-7576	1001990056	F8-5567	1003990025	F8-8179
100 419 0019	LM-10064S	100 742 0014	F8-7580	1001990057	F8-4018	1003990027	F8-5574
100 419 0026	LM-10015S	100 742 0015	F8-7140	1001990062	F8-5346	1003990034	F8-7972
100 422 0001	F8-4076	100 742 0018	F8-7601	1001990062	F8-5398	1003991035	F8-8150
100 422 0001	LM-10029S	100 742 0019	F8-7600	1001990068	F8-5387	1004070001	F8-1017
100 422 0012	LM-10063S	100 742 0024	F8-5992	1001990072	F8-4016	1004070002	F8-1012
100 422 0013	LM-10005S	1001210004	F8-4009	1001990073	F8-4017	1004070012	F8-1007
100 422 9010	LM-10020S	1001210019	F8-4011	1001990074	F8-7748	1004070012/S	F8-1007S
100 501 0005	F8-4081	1001290002	F8-3044	1001990075	F8-7749	1004070013	F8-1024
100 501 0006/S	F8-1010S	1001290005	F8-3045	1001990076	F8-6749	1004070014	F8-1018
100 505 0014	F8-6463	1001290006	F8-3048	1001990077	F8-5540	1004070015	G9-648
100 511 0003	F8-5777	1001290009	F8-4012	1001990078	F8-5524	1004070017	G9-617
100 511 0006	F8-6232	1001300004	F8-7954	1001990079	F8-8189	1004070017/HD	G9-617
100 512 0010	F8-6004	1001300009	F8-8143	1001990085HD	F8-6425	1004070020	G9-540
100 512 0011	F8-6012	1001300011	F8-7971	1001990086HD	F8-6424	1004070022	F8-4045
100 512 0024	AK-735125	1001990002	F8-1003	1001990089	F8-5377	1004070024	G9-616
100 513 0000	F8-5747	1001990003	F8-1004	1001990094	F8-7965	1004070024/HD	F8-5542
100 513 0005	F8-6040	1001990007	F8-4014	1001990095	F8-8152	1004070024/HD	G9-616
100 513 0007	F8-6045	1001990008	F8-4015	1001990097	F8-7960	1004070026	F8-4043
100 513 0010	F8-6350	1001990011	F8-3000	1001990099	F8-7961	1004070027	G9-541
100 513 0013	F8-5765	1001990014	F8-1006	1001990100	F8-7948	1004070030	F8-1013
100 610 0004/HD	F8-7795	1001990015	F8-3040	1001990109	F8-5399	1004070039	F8-4032
100 610 0005	F8-5302	1001990016	F8-4022	1001990112	F8-7958	1004070040	F8-1026
100 610 0008	F8-5303	1001990017	F8-1021	1001990113	F8-6989	1004070041	F8-5105
100 610 0010	F8-6706	1001990018	F8-5547	1001990116	F8-5535	1004070042	F8-3057
100 610 0012	F8-5301	1001990020	F8-3049	1001990117	F8-3054	1004070042/HD	F8-3057
100 610 0015	F8-6705	1001990021	F8-1005	1001990119	F8-7949	1004070043	G9-649
100 610 0021	F8-6582	1001990027	F8-3041	1001990127	F8-7952	1004070047	F8-4044
100 615 0003	F8-5407	1001990028	F8-1015	1001990137	F8-7955	1004070047/HD	F8-4044
100 615 0004	F8-7914	1001990031	F8-6717	1001990143	F8-7966	1004070049/S	F8-1008
100 615 0006	G7-1001	1001990032	F8-5528	1001990148	F8-7968	1004070051	F7-2002
100 640 0005	AK-735116	1001990034	F8-5491	1001990150	F8-7963	1004070052	F8-4038



MEYLE		MEYLE		MEYLE		MEYLE	
1004070053	F8-4039	1004120000	F8-1009B	1004220014	F8-5394	1005120009	F8-7701
1004070054	F8-4037	1004120000/S	F8-1009B	1004221190	G9-678	1005120012	F8-6005
1004070055	F8-4035	1004120002	F8-1009C	1004221191	G9-679	1005120014	F8-6013
1004070056	F8-4036	1004120002/S	F8-1009C	1004980021	MK-830220	1005120018	F8-6007
1004070057	F8-4034	1004120003	F8-1034	1004980085	MK-822920	1005120022	F8-6346
1004070060/HD	G9-615	1004120003/S	F8-1034	1004980127	MK-810160	1005120022	F8-7100
1004070061	F8-5104	1004120004/HD	F8-1027	1004980129	MK-810160	1005120023	F8-6346
1004070073	F8-6464	1004120005	F8-1023	1005010001	F8-1014	1005120023	F8-7101
1004070073/HD	F8-6464	1004120006	F8-4061	1005010002	F8-1016	1005120027	F8-6001
1004070075	F8-6775	1004120007	F8-3009	1005010002S	F8-1016	1005120028	F8-5381
1004070077/HD	F8-6736	1004120010	F8-1002	1005010003	F8-4008	1005120029	F8-6041
1004070082	F8-6151	1004120011	F8-5494	1005010003S	F8-4008	1005120102	F8-5362
1004070083	F7-2001	1004120012	F8-3050	1005010004	F8-4080	1005121008	F8-5402
1004070084	G9-664	1004120013	F8-4066	1005010006	F8-1010	1005130001	F8-5380
1004070084	G9-665	1004120014	F8-5996	1005010007	F8-3052	1005130002	F8-5380
1004070084/HD	G9-664	1004120016	F8-4063	1005010013	F8-5340	1005130004	F8-5572
1004070086	F8-5633	1004120016/S	AK-733023	1005010014	F8-5392	1005130006	F8-6044
1004070090	F8-4038	1004120016/SK	AK-733023	1005010014S	F8-5392	1005130008	F8-6348
1004070093	F8-5132	1004120017	F8-3039	1005010016	G9-665	1005130009	F8-6349
1004070094	F8-7873	1004120019	F8-4067	1005010018	F8-5573	1005130010	F8-7603
1004110000	F8-3042	1004120019/S	F8-4067	1005010019	F8-5343	1006100001	F8-4033
1004110004	F8-3006	1004120019/S	F8-6280	1005010020	F8-6076	1006100003	F8-6784
1004110009	F8-6695	1004120020/HD	F8-1034	1005010025	F8-5341	1006100003/HD	F8-6784
1004110009S	F8-6695	1004120024	F8-5763	1005010025S	F8-5341	1006100005	F8-7745
1004110010	F8-4060	1004120025	F8-4062	1005010032	F8-7938	1006100007	G9-680
1004110012	F8-1029	1004120029	F8-5537	1005010032S	F8-7938	1006100009	F8-6808
1004110013	F8-3005	1004120029/S	F8-6281	1005010033	F8-4082	1006100011	F8-6707
1004110015	F8-4059	1004120033/S	F8-5994	1005050001	F8-5344	1006100014	F8-6701
1004110016	F8-4058	1004120035	F8-3007	1005050003	F8-5530	1006100014/HD	F8-6701
1004110018	F8-4059	1004120039/S	F8-6284	1005050004	F8-7149	1006100017	F8-7448
1004110019	F8-4057	1004120042	F8-7687	1005050008	F8-8133	1006100023	F8-7745
1004110021	F8-5063	1004120044	F8-6283	1005050011	F8-7909	1006100030	F8-7883
1004110024	F8-5235	1004120044	F8-7097	1005050016	F8-7902	1006100032	F8-7882
1004110032	F8-5395	1004120045	F8-3008	1005050018	F8-7924	1006100033	F8-7881
1004110033	F8-5215	1004120048	F8-7454	1005110001	F8-1028	1006150005	F8-6190
1004110033	F8-5221	1004120096	F8-7451	1005110002	F8-1019	1006150007	F8-8105
1004110033/S	F8-5221	1004121019/S	F8-4067	1005110004	F8-7921	1006150007/S	F8-8105
1004110034	F8-5220	1004121019/S	F8-6280	1005110005	F8-5342	1006150011	F8-8106
1004110034S	F8-5220	1004121020/S	F8-1034	1005110007	F8-5541	1006150011/S	F8-8106
1004110036	F8-4053	1004121350	F8-4064	1005110009	F8-5306	1006200001	F8-4070
1004110040	F8-5220	1004129011/S	F8-5523	1005110011	F8-7930	1006400002	AK-735020
1004110040/S	F8-5220	1004129020/S	F8-1034	1005110013	F8-7923	100640001	F8-6282
1004110041	F8-6191	1004130000	F8-5683	1005110015	F8-7979	100640001	F8-7096
1004110046	F8-7922	1004190006	F8-4073	1005120001	F8-5594	1006410002	F8-7575
1004110048	F8-7927	1004190010	F8-4069	1005120005	F8-3010	1006410004	F8-6540
1004110048S	F8-5215	1004190011	F8-4071	1005120006	F8-5393	1006410005	F8-7494
1004110048S	F8-7927	1004190015	F8-5061	1005120007	F8-5403	1006410007	F8-7471
1004110050S	F8-6462	1004190018	F8-4072	1005120007	F8-6382	1006420000	F8-7675
1004110051S	F8-6461	1004190019	F8-4074	1005120008	F8-5402	1006420002	F8-7131
1004110052S	F8-6460	1004220003	F8-4075	1005120008	F8-6382	1006420003	F8-7809



MEYLE		MEYLE		MEYLE		MEYLE	
1006420004	F8-7697	11-14 184 0011	F8-6918	11-140352320	G9-520	16-14 030 0007	F8-6481
1006420005	F8-7703	11-14 184 0013	F8-6486	11-140352331	G9-525	16-14 030 0009	F8-6484
1006420006	F8-7834	11-14 184 0017	F8-6237	11-140352375	F8-5248	16-14 030 0010	F8-5472
1006420007	F8-7174	11-14 184 0018	F8-6898	11-140352376	G9-698	16-14 030 0011	F8-6598
1006420009	F8-7830	11-14 184 0024	F8-5569	11-140352377	G9-699	16-14 030 0020	F8-7009
1006420010	F8-7676	11-14 184 0025	F8-6497	11140500001	F8-5364	16-14 030 0021	F8-6420
1006420011	F8-7716	11-14 184 0028	F8-6507	11140500001	F8-5516	16-14 030 0022	F8-6676
1006420012	F8-7831	11-14 352 0005	F8-5078	11-140510001	F8-5363	16-14 030 0023	F8-5476
1006420015	F8-7715	11-14 352 0010	F8-6535	11141800004	F8-6236	16-14 030 0024	F8-6600
1006420016	F8-7717	11-14 610 0001	F8-5629	11141840001	F8-5358	16-14 030 0025	F8-6711
1006430002	F8-7688	11-14 610 0004	F8-6171	11141840008	F8-8199	16-14 030 0032	F8-6488
1007100003	F8-6430	11-14 610 0005	F8-6172	11141840016	F8-8167	16-14 030 0033	F8-6522
1007100005/HD	F8-6736	11-14 610 0006	F8-5361	11141840030	F8-8169	16-14 030 0034	F8-6502
1007100008	F8-7928	11-14 610 0009	F8-6452	11143520002	G9-558	16-14 030 0053	F8-5478
1007100010	F8-7910	11-14 610 0027	F8-6773	11-143520002	G9-555	16-14 030 0059	F8-6524
1007100011	F8-7911	11-14 610 0045	F8-6587	11-143520005	G9-523	16-14 042 0002	F8-5488
1007100012	F8-7907	11-14 615 0000	F8-5092	11-143520005	G9-523S	16-14 043 4370	F8-5487
1007100013	F8-7908	11-14 615 0001	F8-6127	11143520006	G9-547	16-14 053 0001	F8-5648
1007150002	F8-7798	11-14 615 0003	F8-5213	11-143520007	G9-549	16-14 053 0002	F8-5645
1007150002/S	F8-7798	11-14 615 0004	F8-5077	11143520008	F8-5066	16-14 054 0001	F8-6601
1007400002	AK-735039	11-14 615 0005	F8-6096	11-145030001	F8-5520	16-14 078 0001	F8-4109
1007400002	AK-735095	11-14 615 0006	F8-5062	11-146100003	F8-5669	16-14 080 0002	F8-5482
1007400004	AK-735026	11-14 615 0008	F8-6130	11-146100007	F8-6114	16-14 080 4163	F8-4110
1007410000	F8-6352	11-14 615 0009	F8-6131	11-146100010	F8-7912	16-14 495 0007	M-860860
1007410002	F8-7452	11-14 615 0012	F8-6128	11-146100011	F8-7974	16-14 610 0004	F8-6523
1007420002	F8-6003	11-14 640 0000	AK-735068	11146100012HD	F8-5248	16-14 610 0005	F8-6662
1007420005	F8-7693	11-14 640 0001	AK-735010	11-146100014/HD	G9-549	1614 6100015	F8-5071
1007420009	F8-6723	11-14 641 0008	F8-5508	11146100019	F8-5293	16-14 615 0004	F8-5085
1007420017	F8-6008	11-14 641 0013	F8-6610	11-146100022	F8-5630	16-14 615 0007	F8-5086
1007420021	F8-7658	11-14 641 0013	F8-7467	11-146100023	F8-6114	16-14 620 0001	LM-10032S
1007420023	F8-7674	11-14 641 0014	F8-6611	11146150007	F8-6589	16-14 620 0002	LM-10000S
1007420025	F8-7679	11-14 641 0014	F8-7468	11146150011	F8-6593	16-14 620 0003	LM-10009S
1007420026	F8-7704	11-14 641 0018	F8-3014	11-146410006	F8-7167	16-14 620 0005	LM-10028S
1007420027	F8-7718	11-14 642 0001	F8-6064	11-146410011	F8-6479	16-14 640 0002	AK-735042
1007420028	F8-7714	11-14 642 0002	F8-6063	11-146420005	F8-5935	16-14 641 0002/S	F8-6376
1007420029	F8-7707	11-14 642 0004	F8-7585	11-147410000	F8-6386	16-14 641 0007	F8-6332
1007420030	F8-7719	11-14 642 0007	F8-7588	11-147420003	F8-7673	16-14 641 0014	F8-6335
1007420031	F8-7807	11-14 700 0001	F8-5352	11149600002	F8-5271	16-14 641 0018	F8-5492
1007430002	F8-7682	11-14 700 0002	F8-5351	11166150001	F8-5088	16-14 642 0000	F8-5863
11-14 030 0005	F8-5375	11-14 710 0001	F8-5897	114 615 0000	F8-6708	16-14 710 0000	F8-6174
11-14 050 0002	F8-5519	11-14 710 0007	F8-5871	1146150001	F8-6702	16-14 740 0000	AK-735256
11-14 051 5124	F8-7043	11-14 710 0008	F8-5989	1146150002	F8-6703	16-14 740 0001	AK-735259
11-14 053 0001	F8-5636	11-14 710 0010	F8-5829	1147100009	F8-5340	16140150001	F8-8138
11-14 053 0002	F8-5644	11-14 710 0011	F8-5990	1147100009	F8-6076	16140300005	F8-8151
11-14 053 0005	F8-5660	11-14 710 0013	F8-5799	1147420001	F8-6002	16-140300012	F8-7746
11-14 180 0001	F8-5026	11-14 741 0001	F8-6354	140460001	F7-9001	16140300013	F8-8168
11-14 182 0002	F8-6888	11-14 742 0000	F8-7589	15-14 610 0005	F8-6438	16140300016	F8-8157
11-14 184 0007	F8-5556	11-14 742 0002	F8-7590	15-14 642 0000	AK-735066	16140300017	F8-8172
11-14 184 0009	F8-6485	11140300007	F8-8202	16-14 030 0001	F8-6483	16140300029	F8-8146
11-14 184 0010	F8-6891	11140350000	F8-5099	16-14 030 0004	F8-5359	16140300031	F8-8162



MEYLE		MEYLE		MEYLE		MEYLE	
16140300082	F8-8188	214 641 0002	F8-5598	300 221 1132	F8-6995	3002612198/S	F8-6777
16140424399	F8-5253	214 641 0003	F8-6286	300 221 1601	F8-5430	3002612198/S	F8-6778
16140799064	G9-567	214 641 0006	F8-6288	300 237 1113	F8-6584	3003112001/HD	F8-6774
16140799065	G9-568	214 642 0003	F8-7593	300 247 1102	F8-7022	3003112103/HD	F8-5021
16-140799404	F8-5087	214 642 0011	F8-5937	300 261 2112	F8-7056	3003112103/HD	G9-688
16140819929	G9-603	214 642 0016	AK-735348	300 261 2112/S	F8-7056	3003112104	F8-7797
16140831364	G9-604	214 642 0017	F8-7597	300 261 2911/S	F8-8226	3003112104/HD	F8-7797
16140840741	G9-569	214 642 0020	F8-7594	300 311 0003	F8-6103	3003112107	G9-527
16-14610 0000	F8-7977	214 742 0002	AK-735337	300 311 2901	F8-6243	3003112109	G9-687
16-146100002	F8-7988	214 742 0004	AK-735347	300 313 3104	F8-5690	3003112111	G9-689
16-146100003	F8-7990	214 742 0007	F8-7592	300 313 3106	F8-5766	3003112604/HD	F8-5280
16-146100006	F8-7989	214 742 0010	F8-7596	300 313 3118	F8-5869	3003112604/HD	F8-5281
16-146100007	F8-7992	214 767 3582	F8-5642	300 313 5111	F8-5115	3003112605	F8-6133
16146100008	G9-675	2140500003	G9-504	300 321 1100	LM-10052S	3003112903	G9-625
16146100010	G9-570	2146100001	F8-5273	300 321 3106	LM-10012S	3003112903	G9-625S
16146100011	G9-674	2146100002	G9-530	300 331 7100	F8-5887	3003112905	G9-559
16146100012	G9-653	2146100003	G9-531	300 331 7102	F8-5772	3003112906/HD	G9-637
16146100016	G9-676	2146100004	F8-5276	300 331 7109	F8-5886	3003112906/HD	G9-639
16146100017	G9-677	2146100005	F8-5277	300 331 7110	F7-2041	3003112911	F8-5069
16-146100018	F8-7993	2146100006	F8-5274	300 331 7601/HD	F8-8230	3003112914/HD	G9-658
16146150003	F8-5088	2146100007	F8-5275	300 333 1111	F8-6583	3003112914/HD	G9-658S
16146400000	AK-735240	2146100008	G9-532	300 333 1112	F8-5879	3003112917	G9-638
16-146400000	F8-7900	2146100011	G9-612	300 333 2105	F8-5746	3003112918	G9-623
16146410000	F8-3033	2146100013	F8-6155	300 335 2108	F8-5774	3003112918	G9-624
16146410001	F8-5389	2146100014	F8-6154	300 335 2110	F8-5930	3003113003	G9-625
16146410001/S	F8-5389	2146100022	F8-6244	300 335 3103	F8-5867	3003133103	F8-3063
16146410003	F8-3032	2146100023	F8-5277	300 335 5107	F8-5689	3003133103	F8-6413
16146410004	F8-5496	2146100023	F8-6245	3001181101	F8-6757	3003133105	F8-5506
16-146410005/S	F8-8088	2146100035	F8-6449	3001181105	F8-5432	3003133107/HD	F8-7440
16146410005S	F8-8088	2146420003	AK-735350	3001181106	F8-5428	3003133108	F8-5419
16146410011	F8-6175	2147410001	F8-5563	3001181107	F8-5348	3003133109	F8-7359
16146410013	F8-7152	2147410002	F8-7430	3002211101	F8-5423	3003133110/HD	F8-7439
16146410017	F8-6195	2147673581	G9-533	3002211102	F8-5422	3003133111	F8-7685
16146410019/S	F8-6339	2147673582	G9-534	3002211103	F8-5426	3003133114	F8-5923
16146411001/S	F8-5389	2147700001	F8-3012	3002211104	F8-5425	3003133119	F8-7425
16147100006	F8-6679	2147770001	F8-5858	3002211113	F8-6999	3003133600	F8-5433
214 030 0007	F8-8086	216 610 0001	F8-5264	3002211114	F8-7000	3003133601	F8-5433
214 030 0012	F8-6619	2166100000	F8-5265	3002211119	F8-6714	3003135105	F8-5118
214 030 0013	F8-6622	28-146100005	F8-6576	3002211127	F8-6499	3003135106	F8-5114
214 464 0001	F8-5864	28-146100005	F8-7824	3002211128	F8-7879	3003135107	F8-5119
214 610 0000	F8-6439	28146420000	F8-7444	3002211144	F8-8163	3003135109	F8-7996
214 610 0012	G9-584	28147420000	F8-7443	3002211149	F8-8181	3003221101	F7-2039
214 610 0016	F8-6442	28147420001	F8-7445	3002211150	F8-8182	3003221104	F8-5171
214 610 0019	F8-6246	29-14 610 0001	F8-8219	3002211600	F8-5405	3003331001	F8-6080
214 610 0020	F8-6247	29-146100000	F8-7937	3002371101	F8-8174	3003331101	F8-5317
214 610 0024	F8-6053	29146100003	F8-8014	3002471102	F8-7022	3003331101HD	F8-5317
214 615 0000	F8-6731	300 118 1115	F8-5427	3002612108	F8-6777	3003331102	F8-5003
214 640 0000	AK-735345	300 221 1110	F8-7006	3002612108	F8-6778	3003331103HD	F8-5741
214 640 0002	AK-735018	300 221 1115	F8-7001	3002612112	F8-7056	3003331105/HD	F8-5300
214 641 0000	F8-5600	300 221 1116	F8-7002	3002612112/S	F8-7056	3003331108	F8-5320



MEYLE		MEYLE		MEYLE		MEYLE	
3003331109/HD	F8-5318	314 740 0012	AK-735176	34-146100001	F8-8102	514 135 9100	F8-6993
3003331110/HD	F8-5319	314 740 0013	AK-735229	35 140 100 001	F8-5284	514 306 0003	F8-6994
3003331111HD	F8-6583	3140300001	F8-5424	35-14 610 0006	F8-6642	514 306 0003/S	F8-6994
3003331905	F8-5323	3141520001	F8-6766	35-14 640 0000	AK-735433	514 308 0004	F8-5933
3003331906	F8-5324	3141520003	F8-6762	35140100001	F8-5284	514 610 0002	F8-6718
3003332102	F8-5322	3141520005	F8-6763	35146100002	F8-5282	514 610 0004	F8-6696
3003332103	F8-5321	3141520012	F8-6764	36-14 543 0001	F8-5945	514 620 0000	LM-10061S
3003332104	F8-5311	3141520013	F8-6783	36-14 640 0000	AK-735117	514 640 0000	AK-735123
3003332104/HD	F8-5311	3143110000	F8-5298	36-14 641 0000	F8-7465	514 642 0000	F8-5920
3003332901	F8-7352	3143110000HD	F8-5298	37-14 610 0004	F8-7073	514 642 0001	F8-5919
3003332901	F8-7352S	3146100000/HD	F8-6774	37-14 610 0026	F8-7074	514 742 0000	AK-735307
3003333104	F8-7014	3146100002HD	F8-6574	37-14 615 0001	F8-7061	514 964 1728	F8-5570
3003350101	F8-6782	3146100003HD	F8-6575	37-14 640 0000	AK-735215	5140300001	F8-8156
3003351102/HD	F8-5030	3146150001	F8-7933	37-14 740 0000	AK-735216	5140300003	F8-8148
3003352101/HD	F8-5417	3146150002	F8-7144	37-146100003	F8-7820	5140800001	F8-5106
3003352102/HD	F8-5030	3146150003	F8-7918	37-146100006	F8-6576	5140800004	F8-5983
3003352104/HD	F8-5416	3146150004	F8-7917	37-146100006	F8-7824	5140800004/S	F8-5983
3003352106	F8-5775	3146150005	F8-7931	37-146100006	F8-7998	5140900001	F8-5929
3003352107	F8-5866	3146410002	F8-6368	37-146100013	F8-6576	5141205825	F8-5129
3003352109	F8-6085	3146420001	F8-6088	37-146100013	F8-7824	5141205991	F8-5571
3003352111	F8-7684	3146420003	F8-6543	37-146100016	F8-7821	5141273778	F8-5076
3003353101	F8-5963	3146420004	F8-7334	37-146100017	F8-7822	5141320011	F8-7354
3003353104	F8-6087	3146420006	F8-7812	37-146100023	F8-7817	5141328900/HD	F8-6549
3003355103	F8-7939	3146420007	F8-7332	37146150000	F8-7060	5141329644	F8-5140
3003359102/HD	F8-5030	3146420008	F8-7705	37-146150002	F8-7829	5141378657	F8-7355
3003551105/HD	F8-5932	3146420009	F8-7846	37146420000	F8-7441	5142720004	MK-810160
3003552105/HD	F8-5932	3147100001	F8-7145	40-14 640 0000	AK-735129	5143080001	F8-5249
3006430000	F8-7738	3147400002	AK-735126	40-14 640 0001	AK-735021	5143500002	F8-6759
30-14 640 0000	AK-735301	3147400003	AK-735447	40-14 640 0002	AK-735070	5143540001	F8-5915
30-14 640 0001	AK-735287	3147400004	AK-735448	40-14 640 0003	AK-735111	5146100001/HD	F8-6776
30-14 740 0000	AK-735288	3147410000	F8-7604	40-14 641 0000	F8-6515	5146410002	F8-6337
30146100001	F8-5287	3147420000	F8-7335	40-14 641 0004	F8-5622	5146810001	F8-5242
31-14 300 0002	F8-5982	3147420003	F8-7725	40-14 641 0005	F8-5621	5146819057	F8-5254
31-14 300 0003	F8-5988	3147420004	F8-7710	40-14 642 0001	F8-7587	5147100006	F8-8094
31-14 300 0004	F8-5981	3147420005	F8-7709	40-14 742 0003	F8-7586	5147100014	F8-7877
31143000007	F8-5278	3147420006	F8-7706	40140300001	F8-8184	5147100015	F8-7878
31143000007	F8-5279	3147420007	F8-7702	40140300003	F8-8141	5147410000	F8-6198
31145080045	F8-8159	316 710 0000	F8-6476	40140300004	F8-8149	5147420000	F8-7680
31145130004	F8-6073	316 710 0001	F8-6250	40-146420003	F8-7672	5148630001	F8-8190
31146100005	F8-8027	3160100004	F8-5632	45-140350000	F8-8003	5149180001/S	F8-7695
314 030 0002	F8-6216	3160104347	F8-5299	45140350001	F8-8036	5149180001/S	F8-7695S
314 030 0003	F8-6215	3160104347	F8-7353	45-140350001	F8-8004	5149190001	F8-5245
314 640 0001	AK-735004	3160604225	G7-767	514 012 0000	F8-5899	5149280002/S	F8-7696
314 640 0003	AK-735412	32-14 610 0008	F8-7129	514 030 0002	F8-6992	5149280002/S	F8-7696S
314 640 0005	AK-735422	32-14 640 0000	AK-735024	514 030 0011	F8-6882	5149641728	F8-7947
314 640 0006	AK-735228	32-14 740 0000	AK-735121	514 122 9165	F8-5718	516 035 0000	F8-6469
314 642 0002	F8-6542	33144550001	F8-5288	514 122 9714	F8-5762	53-14 640 0000	AK-735384
314 740 0005	AK-735171	33144550002	F8-5289	514 127 3622	F8-5691	614 030 0002	F8-6203
314 740 0007	AK-735421	34146100000	F8-5286	514 133 0427	F8-5735	614 030 0005	F8-6494
314 740 0009	AK-735173	34146100001	F8-8102	514 133 0973	F8-5736	614 030 0007	F8-6981



MEYLE		MEYLE		MEYLE		MEYLE	
614 030 0014	F8-6975	6140300019	F8-8170	6140900002	MK-822300	6160100100	F8-5201
614 030 0015	F8-6978	6140300021	F8-8183	6141200001	F7-2055	700 620 0000	F8-5051
614 030 0017	F8-6983	6140340000	F8-5589	6141530000	F8-7089	700 620 0000	LM-10023S
614 030 0044	F8-6982	6140340001	F8-5450	6141600013	M-820820	714 006 0001	F8-6015
614 034 0002	F8-3059	6140340004	F8-5501	6141600013	MK-820820	714 006 0002	F8-6016
614 034 0003	F8-5501	6140340004	F8-7973	6143440000	F8-7584	714 030 0004	F8-6926
614 034 0009	F8-4100	6140340005	F8-5304	6143440007	AK-735038	714 030 0012	F8-6475
614 034 1005/S	F8-5304	6140340006	F8-5448	6143440008	F8-5966	714 101 0000	F8-5412
614 035 0013	G9-591	6140340007	F8-5463	6143520000	F8-5130	714 101 1000/S	F8-5412
614 035 0018	F8-4090	6140340008	F8-3026	6145400005	F8-7913	714 102 0000	F8-5410
614 035 0018	F8-5251	6140340010	F8-5434	6145680001	F8-8195	714 110 0001	F8-5328
614 035 0019	G9-555	6140340011	F8-7372	6145680004	F8-6740	714 125 0001/S	F8-8213
614 035 0020	F8-5331	6140340017	F8-7329	6145680006	F8-8142	714 130 0006	F8-6754
614 035 0022	F8-6091	6140340023	F8-7327	6145680007	F8-5365	714 610 0002	F8-6162
614 035 0026	F8-5211	6140341004/S	F8-5501S	6145680009	F8-8137	714 610 0003	F8-6163
614 035 0034	F8-6656	6140341005/S	F8-5304S	6145680012	F8-8155	714 610 0004	F8-6159
614 035 0037	F8-6447	6140350002/HD	F8-5334	6146100001	F8-7946	714 610 0005	F8-6160
614 040 0001	F8-4102	6140350002/HD	F8-5969	6146100008	F8-6729	714 610 0014	F8-6157
614 040 0002	F8-4101	6140350002/S	F8-5251	6146150000	F8-7945	714 610 0015	F8-6158
614 040 0003	F8-5552	6140350002/S	F8-5334	6146150001	F8-7945	714 614 0001	F8-5204
614 040 0004	F8-3060	6140350002/S	G9-594	6146150002	F8-7857	714 615 0000	F8-3020
614 040 0005	F8-5911	6140350003	G9-593	6146150002	F8-7857S	714 615 0002	F8-5330
614 040 0007	F8-5337	6140350004	G9-590	6146410001	F8-6517	714 640 0000	AK-735033
614 042 0001	F8-5723	6140350005	F8-4098	6146410007	F8-8085	714 640 0001	AK-735034
614 042 0002	F8-6098	6140350006/HD	F8-4097	6146420000	F8-7698	714 640 0005	AK-735431
614 042 0004	F8-5722	6140350006/HD	F8-5150	6146420002	F8-7662	714 641 0011	F8-6268
614 044 0001	F8-6660	6140350006/S	F8-4097	6146420003	F8-7699	714 642 0002	F8-7581
614 044 0008	F8-5970	6140350007	F8-4090	6146430000	F8-7663	714 642 0003	F8-7582
614 045 0001	F8-4106	6140350008	F8-5110	6146820001	F8-8166	714 671 0000	F8-6137
614 045 0002	F8-7053	6140350009	F8-5333	6146820002	F8-8145	714 710 0000	F8-6034
614 160 0001	MK-822920	6140350010	F8-5109	6146820004	F8-5444	714 723 0002	F8-8224
614 344 0001	F8-5692	6140350011	G9-591	6146840003	F8-5439	714 740 0000	AK-735082
614 344 0007	F8-5878	6140350012	G9-592	6146840004	F8-5436	714 740 0001	AK-735035
614 436 0001	F8-5721	6140350014	F8-5101	6146840005	F8-5437	714 740 0002	AK-735409
614 436 0002	F8-5912	6140350016	F8-5108	6146840006	F8-5371	714 741 0001	F8-7455
614 540 0001	F8-5335	6140350017	F8-5128	6146840007	F8-5367	714 741 0003	F8-6358
614 540 0002	F8-5336	6140350021	F8-5228	6146840008	F8-5373	714 742 0002	F8-7583
614 568 0002	F8-6836	6140350027	F8-5262	6146840010	F8-5468	7140300013	F8-8165
614 610 0005	F8-6673	6140350028	F8-7929	6146840012	F8-5372	7140300019	F8-8139
614 610 0006	F8-6674	6140350029	F8-7925	6146840013	F8-5368	7140300022	F8-8197
614 620 0004	LM-10041S	6140350032	F8-7926	6146840015	F8-5418	7140320002	F8-6756
614 640 0000	AK-735003	6140350033	F8-5263	6146840016	F8-5467	7140530001	F8-6387
614 640 0002	AK-735250	6140350033	G9-556	6146840019	F8-5462	7140640001	F8-6060
614 640 0005	AK-735005	6140350035	F8-5332	6146840020	F8-5438	7141000001	G9-585
614 682 0003	F8-5445	6140350036	F8-5230	6146840023	F8-5370	7141010001	G9-662
614 684 0014	F8-6835	6140420005	F8-7373	6146840024	F7-2059	7141010002	G9-663
614 684 0018	F8-6959	6140440002	F8-5338	6146840029	F8-8161	7141010010	F8-5411
614 684 0026	F8-6826	6140440003	F8-5724	6146840030	F8-8158	7141010011	F8-6074
6140300001	F8-6753	6140440004	F8-7919	6147100000	F8-7944	7141011000/S	F8-6312
6140300009	F8-7794	6140680001	F8-5442	6147420001	F8-7847	7141020001	G9-634



## MEYLE

7141030001	G9-586
7141030002	F8-5562
7141060001	F8-6066
7141250001	F8-7431
7141300010	F8-8140
7141610002	F8-5075
7141610002	G9-522
7141650001	G9-501
7141650001	G9-501S
7141650001/S	G9-501
7141650001/S	G9-501S
7145020001	G9-500
7146100001	F8-5252
7146100012	F8-8074
7146100013	F8-8075
7146100021HD	F8-8078
7146150001	F8-5507
7146150003	F8-6732
7146190002	G9-524
7146410001	F8-5408
7146410002	F8-6318
7146410003	F8-6308
7146410004	F8-6164
7146410005	F8-6510
7146410009	F8-7606
7146410009/S	F8-7608
7146430000	F8-7686
7146430001	F8-7683
7146490001	F8-5522
7146510003	F8-5135
7146760001	F8-5505
7146760001	F8-6313
7146790001	F8-5504
7146790002	G9-633
7146830001	F8-5503
7146870001/HD	F8-5136
7147100001	F8-6638
7147100002	F8-7935
7147100003	F8-5329
7147100004	F8-8001
7147110001	F8-7940
7147230001	F8-5406
7147350000	F8-5447
7147370001	F8-5329
7147370001	F8-5971
7147410000	F8-6511
7147410002	F8-6357
7147420000	F8-6061
7160600024S	F8-6118
7166150000	F8-7934

## MEYLE

8144540001/HD	F8-6547
8144540002	F8-7147
8145060001	F8-6327
8148961476	G9-643
8148965253/HD	G9-641
WM-G 3632	F8-7031





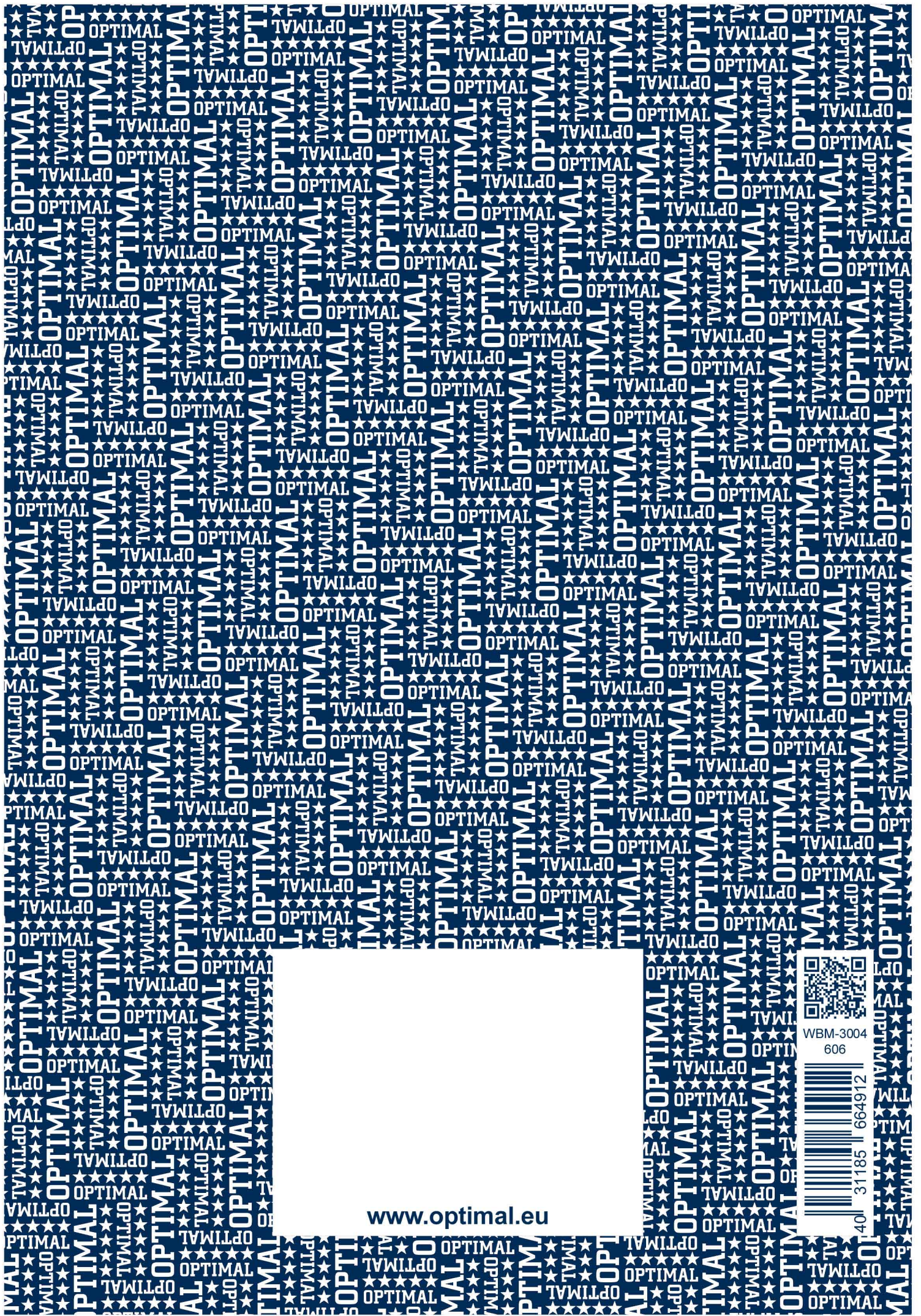

[www.optimal.eu](http://www.optimal.eu)



WBM-3004  
606



40 31185 664912