

Product Range

Edition 2015





*Quality is never accident;
it is always the result of intelligent effort.*
John Ruskin

All Original Equipment Manufacturer part numbers and Cross reference code numbers at the PEGA catalogue are itemized just for comparing.

It is not implied that any part listed is the product of these manufacturer.

We do not guarantee the accuracy or reliability and accept no liability for any loss or damage arising from any inaccuracies or omission in this catalogue

The contents of this catalogue must not be copied or reproduced without the written permission from PEGA Otomotiv Süspansiyon San. ve Tic. A.Ş.

©2015 by PEGA Otomotiv Süspansiyon San. ve Tic. A.Ş. All Rights Reserved.

Tüm OEM parça numaraları ve Çaprazlama İletişimindeki ürün kodları PEGA ürün kataloğunda sadece karşılaştırma amacı ile yer almaktadır.

PEGA Kataloğunda belirtilen ürün o üreticinin ürünü olduğuna dair bir bilgi yer almamaktadır.

Kataloğda yer alan bilgilerin kesinliğine dair bir garanti vermiyoruz ve belirtilen ürün kriterlerinden ya da teknik bilgilerden kaynaklanan hata ya da zararlardan dolayı sorumluluk kabul etmiyoruz.

Bu kataloğda yer alan bilgi ve resimler PEGA Otomotiv Süspansiyon San. ve Tic. A.Ş.'nin yazılı izni olmadan çoğaltılamaz ve farklı amaçlar için kullanılamaz.

©2015 PEGA Otomotiv Süspansiyon San. ve Tic. A.Ş. Tüm Hakları Saklıdır

EXPERIENCE AND POWER AT YOUR SIDE

PEGA OTOMOTIV SUSPANSIYON SAN.VE TIC.A.S. was established in 2008 by a team well experienced on developing, manufacturing and marketing air suspension systems on the International market for years. The built up knowledge attained by multinational companies and the high quality products have brought PEGA's name up to its righteous place on the World market.

Pega, as a major air spring manufacturer, is competing with the sector leaders in 75 countries all over the World with a high quality products and a range of over 900 types. Our main strength is our target to gain a maximum customers' satisfaction by providing constant improvement, high quality products and reliable services, which is a sine qua non "a must " of our market. PEGA OTOMOTIV SUSPANSIYON SAN.VE TIC.A.S. is certificated according to ISO TS 16949:2009 and ISO 14001:2004 standards to prove its quality and willingness to strengthen its continuous improvement.

Warranty Information

Pega® air springs that use in Buses, Trucks or Trailers have Standard two-year limited warranty featuring no mi/km restriction against failure due to material or workmanship defects.

WARRANTY HAVE SOME EXCLUSIONS:

- If an external solid matter caused a defect to the air spring.
- Operation of the air springs without air pressure or under the min. riding height.
- Over extension.
- Overloading the vehicle.
- Misalignment.
- Wrong installation.
- Using air spring in incorrect place.

TWO YEAR WARRANTY

Pega® air springs have been designed to provide thousands of miles or kms of trouble free service. The durability of Pega® Air spring is such that they will often outlast other maintenance items; such as shocks, bushings and levelling valves or other concerned parts related to the suspension system of vehicle. Pega® air springs are warranted to be free of material defects and/or workmanship for 2 years, depending upon the application. Free replacements may be provided by the manufacturer, dealer or by any Pega® air spring distributor (for details, please contact with customer representative). Since each individual air spring is closely examined and pressure tested at our production plant in Bursa, TURKEY. The vast majority of premature failures and consequent warranty returns are found not to be defected, but fail because of abuse caused by other problems associated with the suspension. Before you install a new air spring, you should carefully examine to determine what caused it to fail. If there was any problem in the suspension system, then the new air spring will also fail unless you correct the problem.



IMPORTANT DETAILS

• WARNING!

Do not inflate unless fully secured in the suspension or other adequate structure at design height. Improper use or over inflation may cause assembly to burst causing property damage and/or injury could result.

Working temperature -40°C to +70°C, -40°F to +158°F

• STORAGE

Air springs should be kept in a dark and dry storage area at normal room temperature.

• CHEMICAL RESISTANCE

Air Springs are;

Suitable for operation temperature from -40°C to +70°C, -40°F to +158°F

Resistant to oil contaminated compressed air

Resistant to chemical non-aggressive dust

Resistant to alkaline and acidic cleaning agent

Resistant to ozone

• AIR SPRINGS ARE NOT RESISTANT TO:

Solvents

Hydraulic oils

Lubrication grease

The components of PEGA airsprings



- 1- Mounting stud
- 2- Combo stud
Combination mounting stud and air fitting.
- 3- Plate
- 4- Outer rubber
- 5- Cord fabric
- 6- Inner rubber
- 7- Internal bumper
(Optional)
- 8- Piston
(Available in aluminium, steel or fibre-reinforced plastic)
- 9- Piston bolt
- 10- Bead ring
- 11- Blind nut
- 12- Air fitting hole
- 13- Girdle hub
- 14- Clamp plate
- 15- Clamp ring
- 16- Shock absorber
- 17- Air fitting
- 18- Ring mounting
(Built-in)
- 19- Ring mounting
(Replaceable bushings)
- 20- Metal rod

Complete rolling lobe

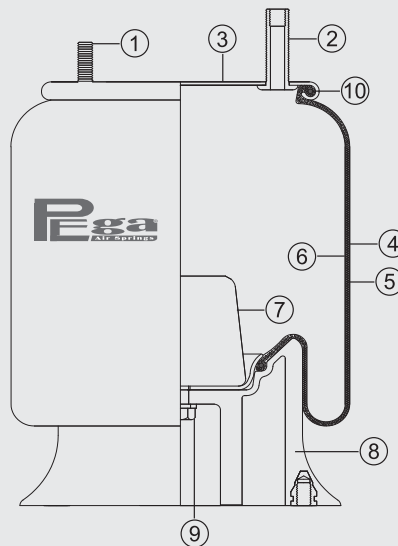

Cabin Airspring w/shock absorber

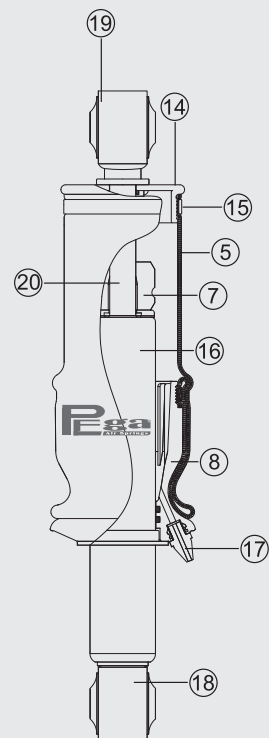

Convuluted bellow

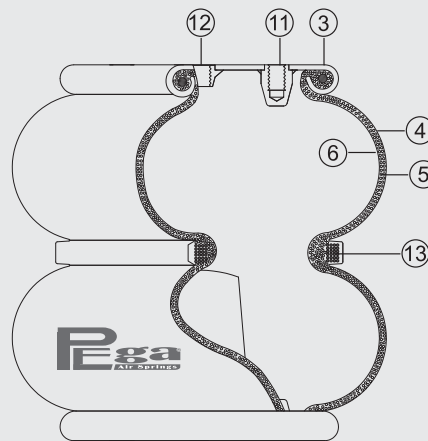

Sleeve type rolling lobe

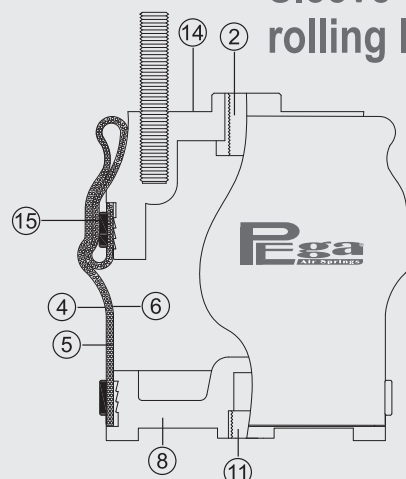

“Service Assembly”

A “Service assembly” includes a plate, bellows, internal bumper (if any), and all attaching hardware

Pega[®]
Air Springs
North America

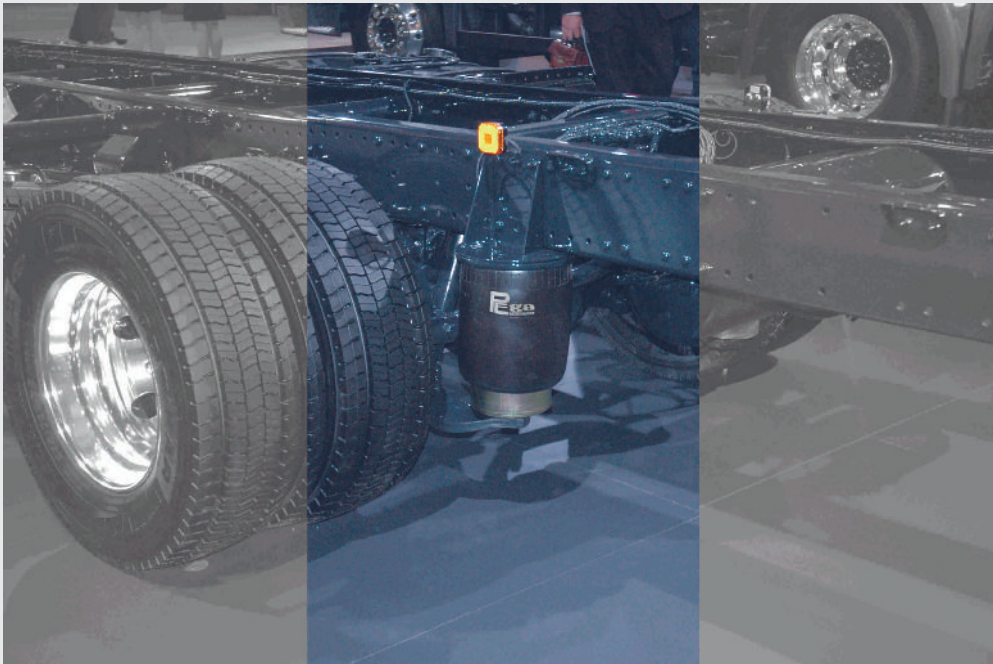

P10.0040.CP

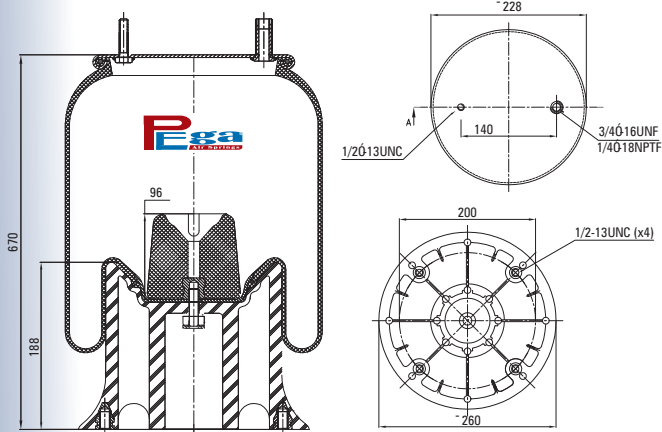

Cross References

CONTITECH	9 10-19 P 315
FIRESTONE	1T15M9 W013589101
GOODYEAR	1R12-103

OE Part No

HENDRICKSON	B-3842
LOADGUARD	SC2038
NAVISTAR	554768C1
SAF HOLLAND	90557082
SAF HOLLAND	90044701
SAF HOLLAND	90054218
SAF HOLLAND	90557008
SAF HOLLAND	90557009
SAF HOLLAND	90557043
SAF HOLLAND	90044201
WATSON & CHALIN	AS-0040

PLASTIC PISTON

7,2 KG.

P10.1740.C

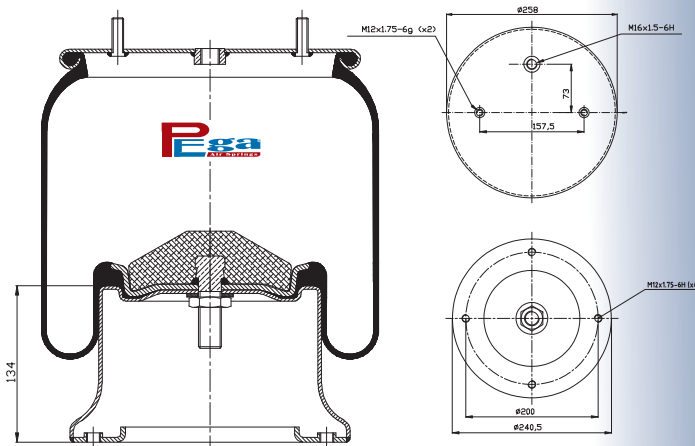

Cross References

GOODYEAR	1R11-740
----------	----------

OE Part No

DAF	16 16 000
-----	-----------

METAL PISTON

7,8 KG.

P10.1825.CP

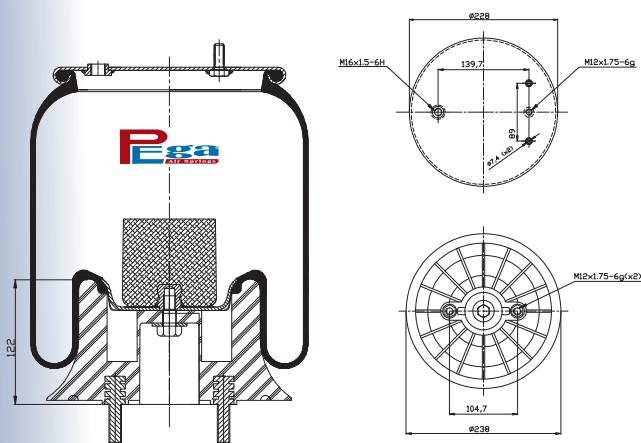

Cross References

GOODYEAR	1R11-825
----------	----------

OE Part No

HENDRICKSON	HS507149
-------------	----------

PLASTIC PISTON

5,7 KG.

P10.2642.CP

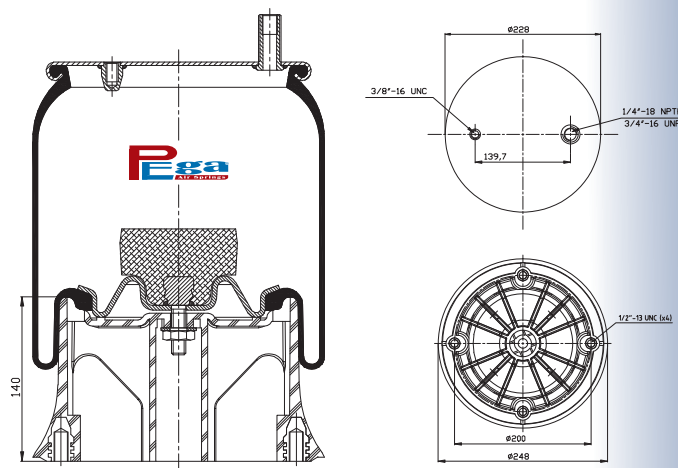

Cross References

GOODYEAR	1R12-642
----------	----------

OE Part No

PLASTIC PISTON

7 KG.

P10.7369.CP

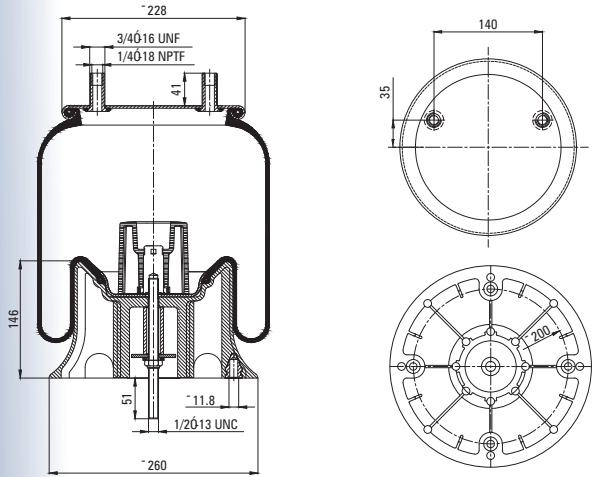

Cross References

OE Part No

SAF HOLLAND (NEWAY) 90557369

PLASTIC PISTON

7,3 KG.

P10.7372.CP

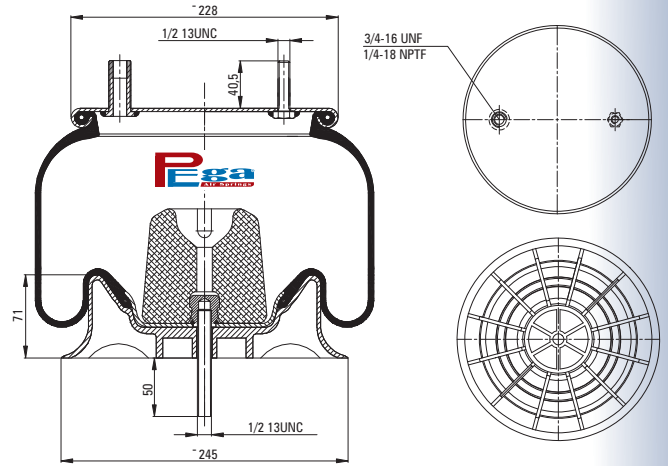

Cross References

OE Part No

SAF HOLLAND (NEWAY) 90557372

PLASTIC PISTON

5,2 KG.

P10.8050.C

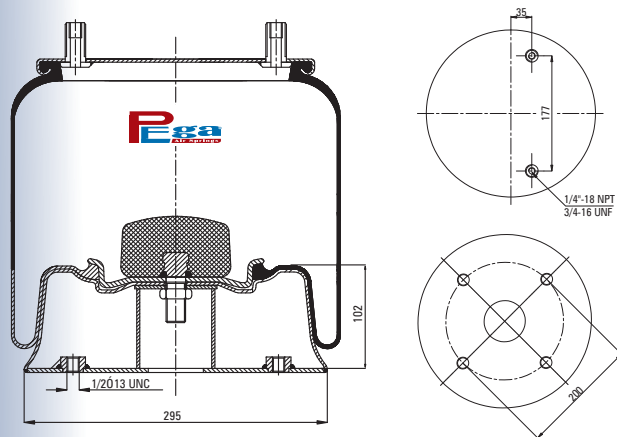

Cross References

OE Part No

CONTITECH 11 10.5 E-16 A 320
FIRESTONE 1T192K-5.7
W01 358 8050

HENDRICKSON TRAILER S4771

METAL PISTON

10 KG.

P10.8051.C

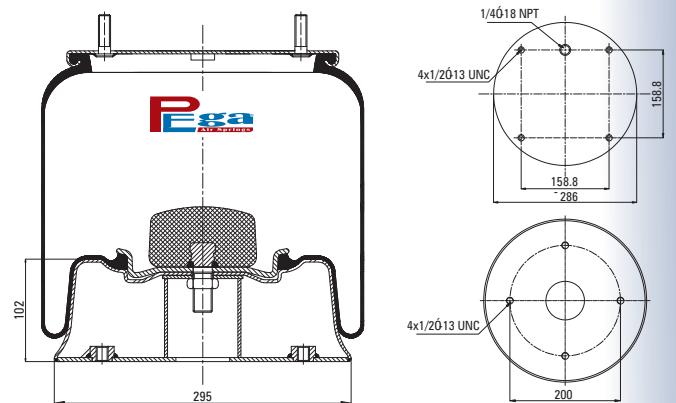

Cross References

OE Part No

CONTITECH 11 10.5 C-16 A 385
FIRESTONE 1T19J-6
W01 358 8051

RIDEWELL 1003588051C
HENDRICKSON CANADA B-12514-013
WATSON & CHALIN AS-0039

METAL PISTON

10 KG.

P10.8052.C

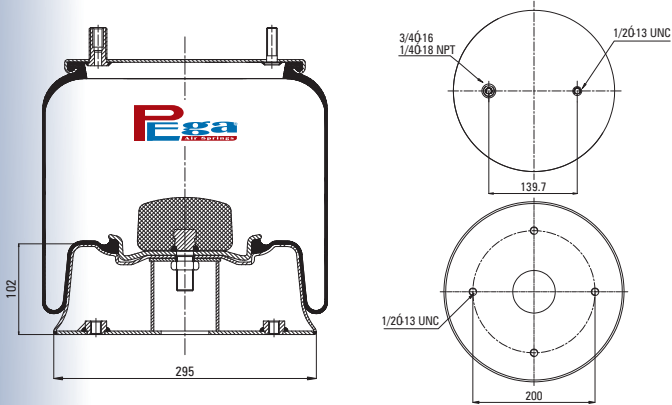

Cross References	
CONTITECH	11 10.5 C-16 A 378
FIRESTONE	1T19J-6 W01 358 8052

OE Part No	
WATSON & CHALIN	AS-0078
WATSON & CHALIN	AS-0039
HENDRICKSON CANADA	B-12514-012

METAL PISTON

10 KG.

P10.8053.C

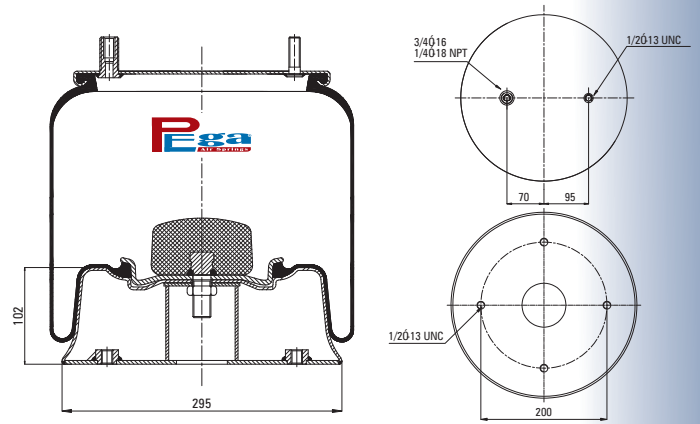

Cross References	
CONTITECH	11 10.5 C-16 A 380
FIRESTONE	1T19J-6 W01 358 8053

OE Part No	
SAF HOLLAND (NEWAY)	90557098

METAL PISTON

10 KG.

P10.8637.C

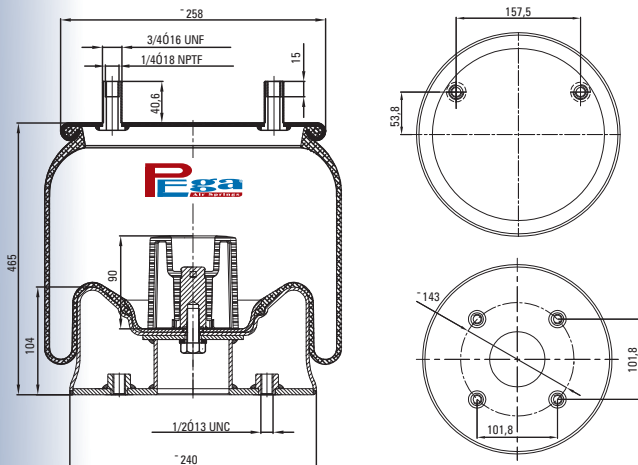

Cross References	
CONTITECH	10 10-16 S 724
FIRESTONE	W013858637

OE Part No	
WATSON & CHALIN	AS-0107G

METAL PISTON

9 KG.

P10.8708.CP

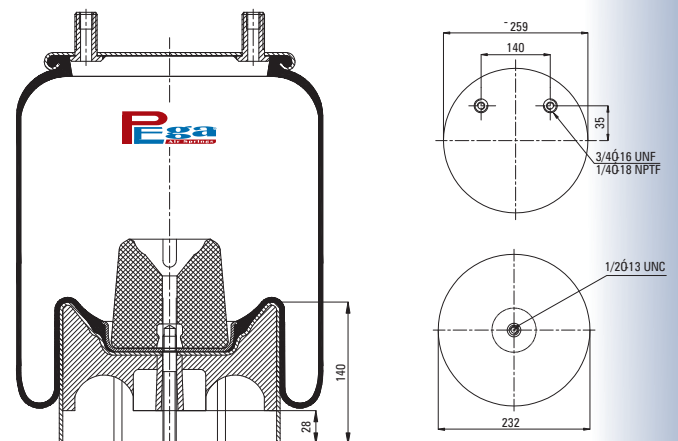

Cross References	
FIRESTONE	1T17CA-6.5 W01 358 8708
CONTITECH	10 10-16 S 526

OE Part No	
HENDRICKSON TRAILER	S 21966
HENDRICKSON	28929

PLASTIC PISTON

7,5 KG.

P10.8709.CP

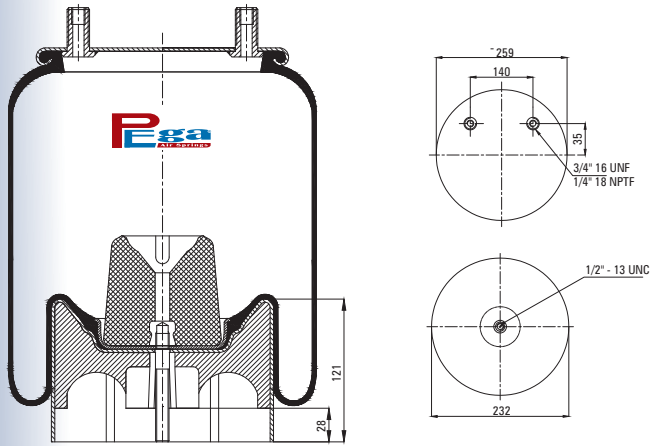

Cross References		OE Part No
CONTITECH	10 10-5 P 460	HENDRICKSON TRAILER S 21800
FIRESTONE	1T17CA-5 W01 358 8709	
GOODYEAR	1R13-159	

PLASTIC PISTON 7,5 KG.

P10.8749.CP

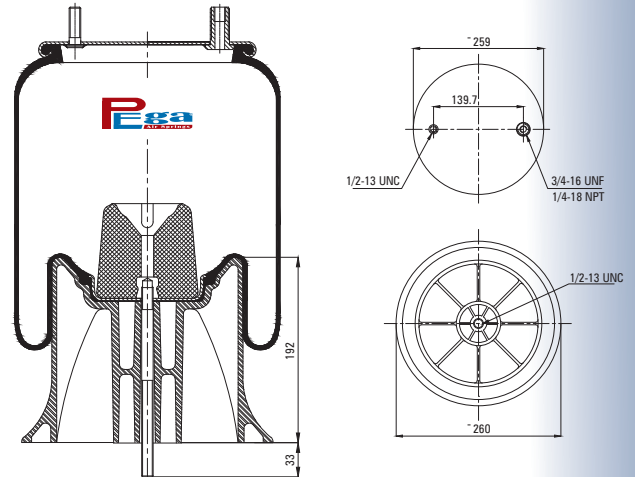

Cross References		OE Part No
CONTITECH	10 10-21 P 486	SAF HOLLAND (NEWAY) 90557168
FIRESTONE	1T17B-11 W01 358 8749	

PLASTIC PISTON 7 KG.

P10.8752.C

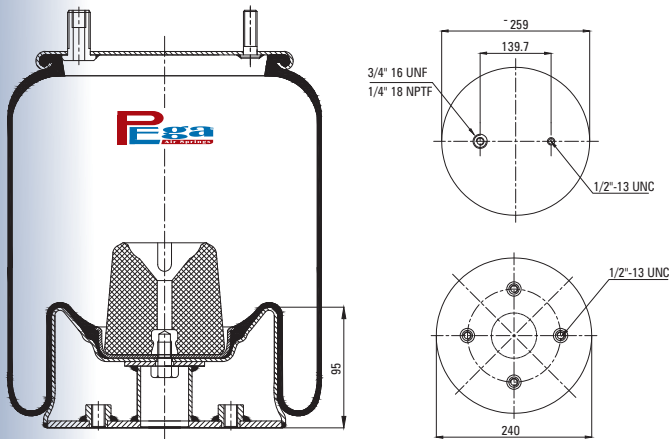

Cross References		OE Part No
CONTITECH	10 10-15 S 518	RIDEWELL 1003588752C
FIRESTONE	1T17B-5 W01 358 8752	WATSON & CHALIN AS-0084

METAL PISTON 8,5 KG.

P10.8753.C

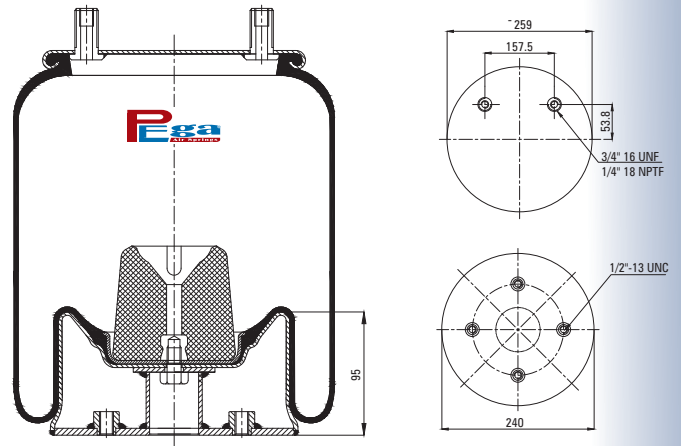

Cross References		OE Part No
CONTITECH	10 10-15 S 713	RIDEWELL 1003588753C
FIRESTONE	1T17B-5 W01 358 8753	WATSON & CHALIN AS-0098

METAL PISTON 8,5 KG.

P10.8755.C

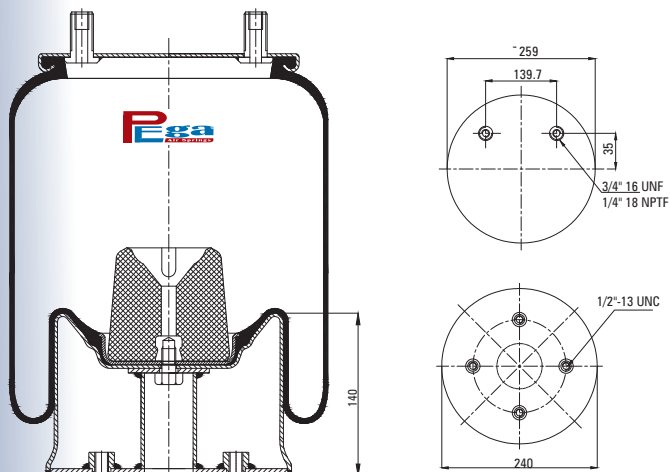

Cross References

CONTITECH 10 10-15 S 522
 FIRESTONE 1T17B-5
 W01 358 8755

OE Part No

HENDRICKSON TRAILER S22045

METAL PISTON

10 KG.

P10.8805.CP

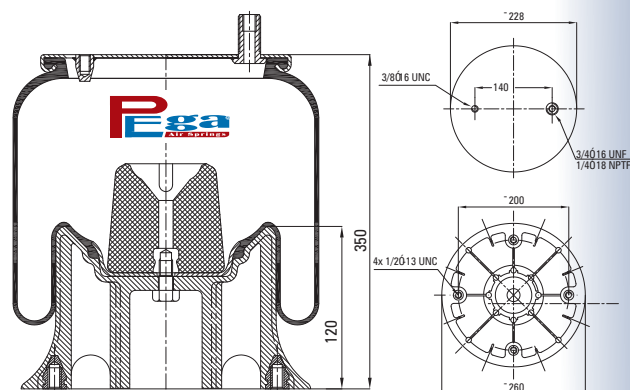

Cross References

CONTITECH 9 10-14 P 462
 FIRESTONE 1T15M-4
 W01 358 8805

OE Part No

RIDEWELL 1003588058C
 NAVISTAR / FLEETRITE 1675495C1
 NAVISTAR / FLEETRITE 2027913C3

PLASTIC PISTON

6 KG.

P10.8806.CP

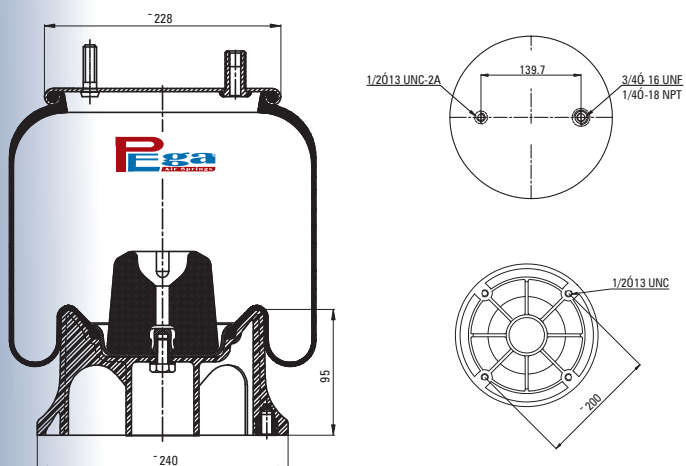

Cross References

CONTITECH 9 10-14 A 545
 FIRESTONE 1T15M-4
 W01 358 8806

OE Part No

RIDEWELL 1003588806C

PLASTIC PISTON

6,6 KG.

P10.8810.CP

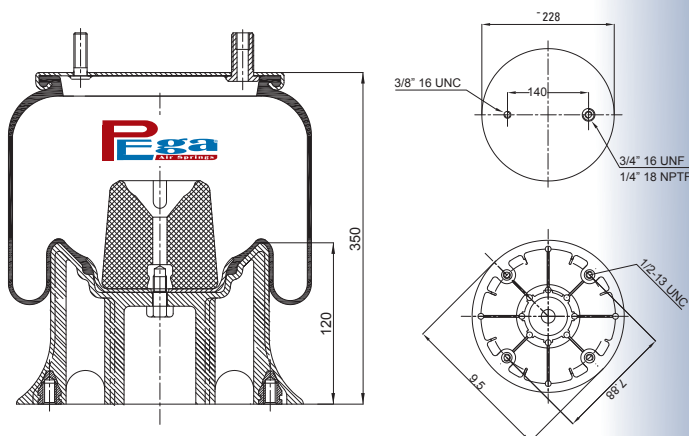

Cross References

CONTITECH 9 10-14 A 546
 FIRESTONE 1T15M-4
 W01 358 8810

OE Part No

HAGIE

PLASTIC PISTON

5,7 KG.

P10.8829.CP

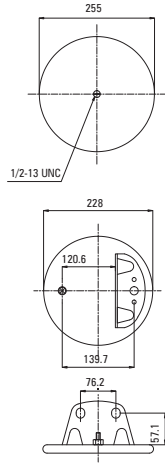
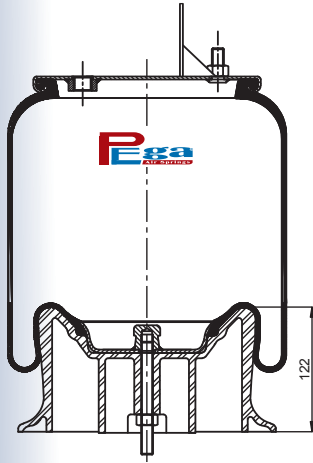

Cross References

CONTITECH	9 10-16 P 499
FIRESTONE	1T15M-6
	W01 358 8829
GOOD YEAR	1R12-615

OE Part No

HENDRICKSON	HA 100016
-------------	-----------

PLASTIC PISTON

6 KG.

P10.8852.CP

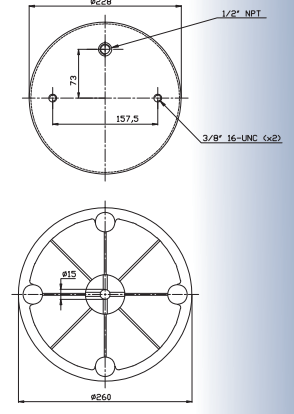
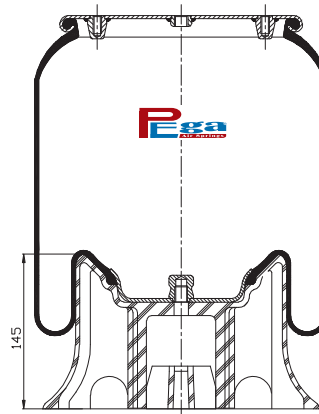

Cross References

CONTITECH	9 10-19 P 472
GOODYEAR	1R12-568
FIRESTONE	1T15M9
	W013588852

OE Part No

PETERBILT	03-07887
-----------	----------

PLASTIC PISTON

5,6 KG.

P10.8864.CP

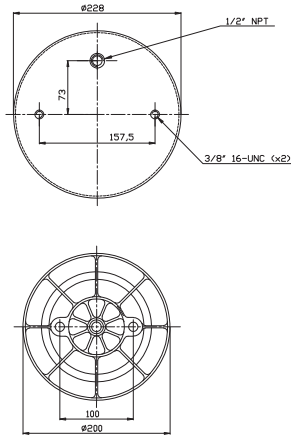
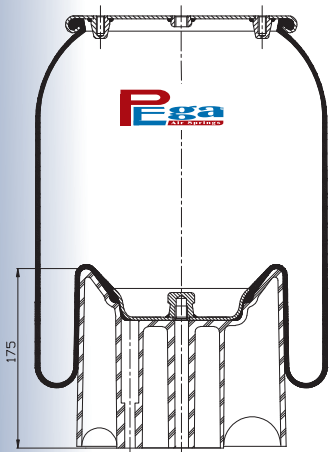

Cross References

CONTITECH	9 10-19 P 898
FIRESTONE	1T15M9
	W013588864

OE Part No

PETERBILT	03-08716
-----------	----------

PLASTIC PISTON

5,6 KG.

P10.9008.CP

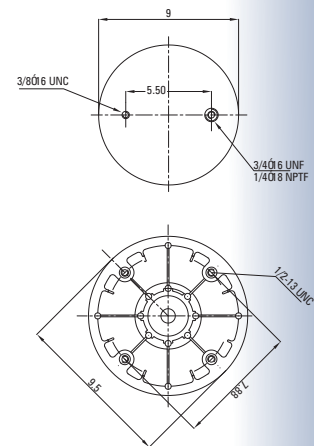
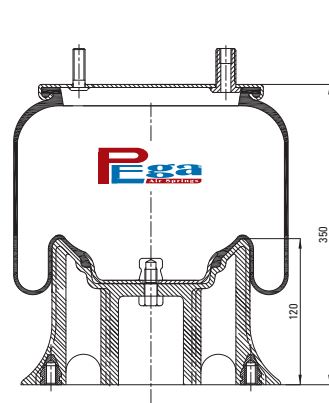

Cross References

CONTITECH	9 10-14 P 344
FIRESTONE	1T15M-4
	W01 358 9008

OE Part No

RIDEWELL	1003589008C
----------	-------------

PLASTIC PISTON

6 KG.

P10.9010.CP

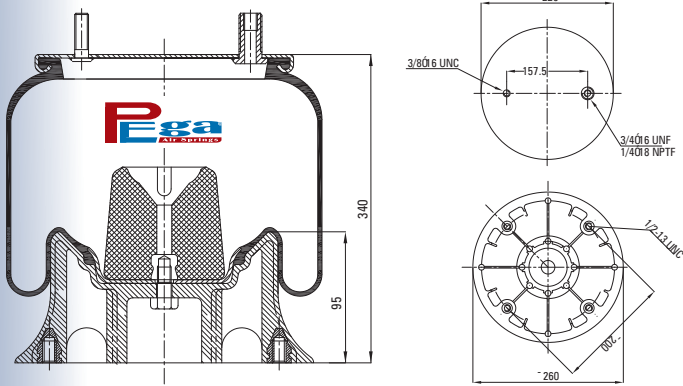

Cross References

CONTITECH	9 10-14 P 345
FIRESTONE	1T15M-4
	W01 358 9010
GOODYEAR	1R12-352
GOODYEAR	1R12-421

OE Part No

HENDRICKSON	S-2827
HENDRICKSON	S-11566
REYCO	12928-01
RIDEWELL	1003589010C
WATSON & CHALIN	AS-0044

PLASTIC PISTON

6 KG.

P10.9011.CP

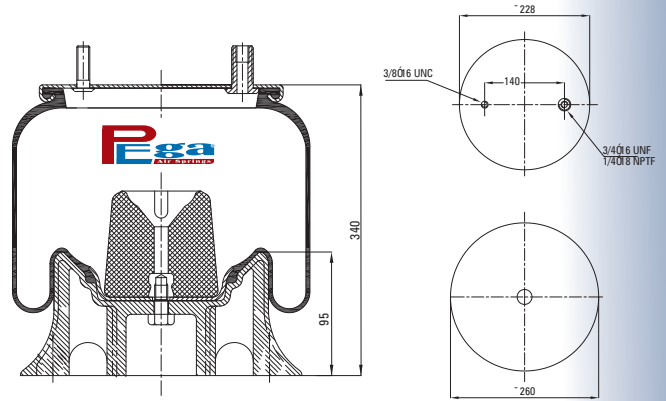

Cross References

CONTITECH	9 10-14 P 346
FIRESTONE	1T15M-4
	W01 358 9011

OE Part No

HENDRICKSON TRAILER	S 2307
---------------------	--------

PLASTIC PISTON

6 KG.

P10.9026.CP

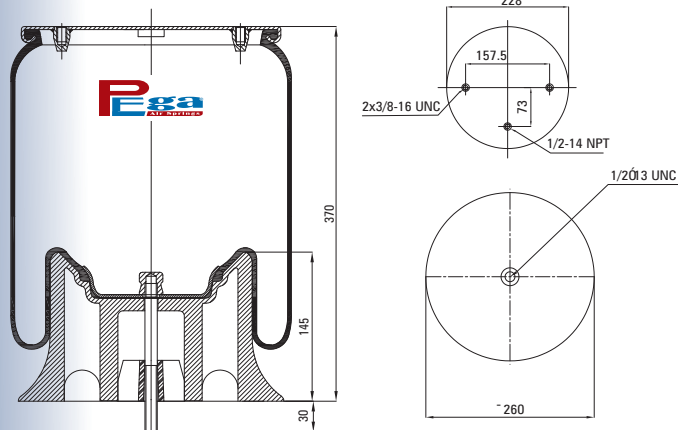

Cross References

CONTITECH	9 10-16 P 393
FIRESTONE	1T15M-6
	W01 358 9026

OE Part No

PETERBILT	03-06213
PETERBILT	03-07111

PLASTIC PISTON

5,5 KG.

P10.9059.CP

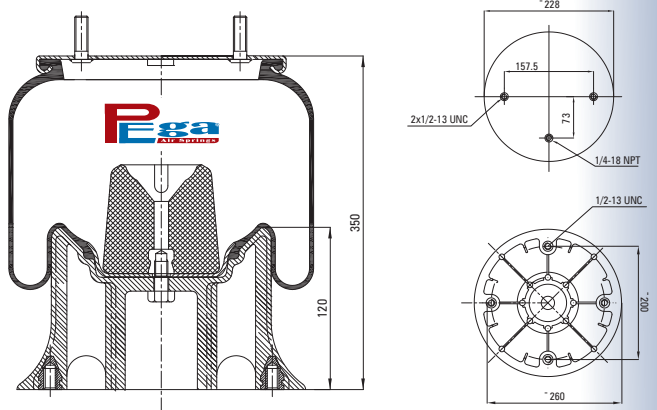

Cross References

CONTITECH	9 10-14 P 335
FIRESTONE	1T15M-4
	W01 358 9059

OE Part No

HUTCHENS	H-1913-1
----------	----------

PLASTIC PISTON

6,5 KG.

P10.9063.CP

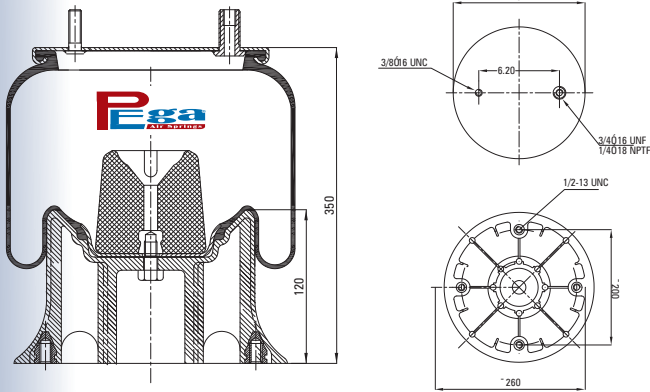

Cross References	
CONTITECH	9 10-14 P 347
FIRESTONE	1T15M-4
	W01 358 9063

OE Part No	
NAVISTAR	359519C-1

PLASTIC PISTON

6,5 KG.

P10.9068.CP

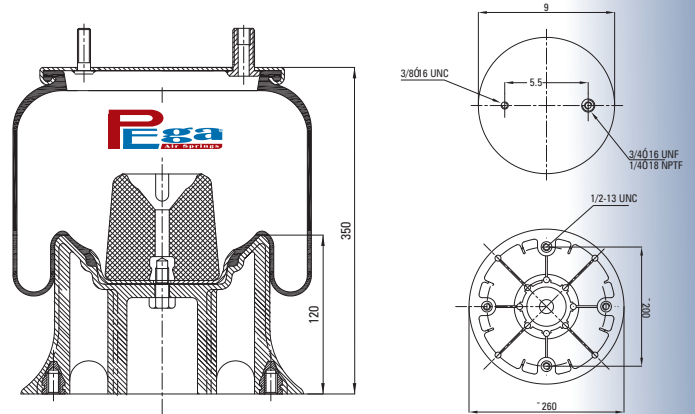

Cross References	
CONTITECH	9 10-14 P 348
FIRESTONE	1T15M-4
	W01 358 9068

OE Part No	
NAVISTAR	350449C-1

PLASTIC PISTON

6,5 KG.

P10.9069.CP

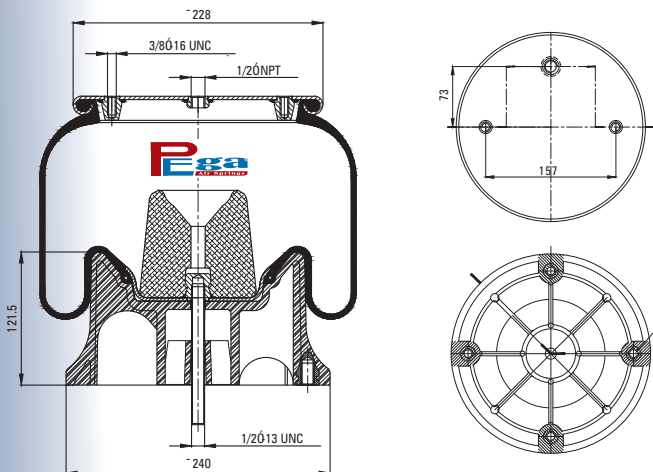

Cross References	
CONTITECH	9 10-14 P 312
FIRESTONE	1T15M-4
	W01 358 9069
GOODYEAR	1R12-669

OE Part No	
PETERBILT	03 7112
HENDRICKSON	S13031
LOADGUARD	SC2034
PETERBILT	03-02456
PETERBILT	03-04759
WATSON & CHALIN	AS-0077

PLASTIC PISTON

6 KG.

P10.9070.CP

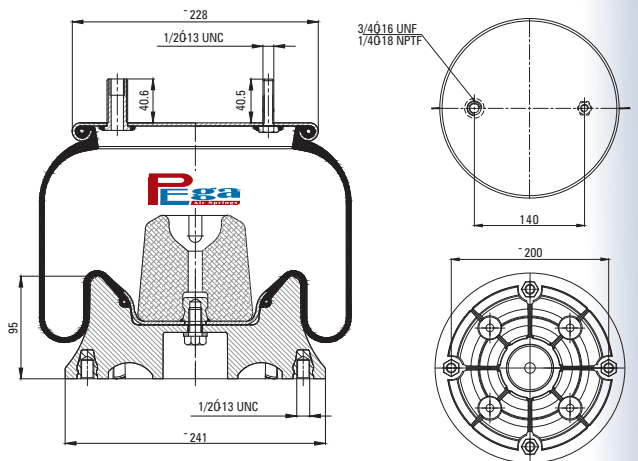

Cross References	
CONTITECH	9 10-14 A 330
FIRESTONE	1T15M-4
	W01 358 9070
GOODYEAR	1R12-370

OE Part No	
NEWAY	905 57 038
NEWAY	905 57 090
LOADGUARD	SC2775
WATSON & CHALIN	AS0050

PLASTIC PISTON

7 KG.

P10.9082.CP

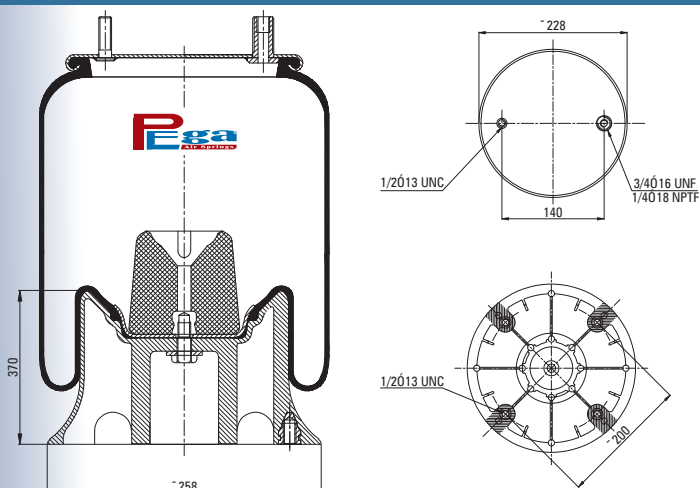

Cross References

CONTITECH	9 10-16 P 310
FIRESTONE	1T15M-6 W01 358 9082
GOODYEAR	1R12-092

OE Part No

HENDRICKSON	B 2066
HENDRICKSON	36514-7/S11651
HENDRICKSON	B-12514-007
LOADGUARD	SC2035
NAVISTAR	517559C9
SAF HOLLAND (NEWAY)	905 570 06 905 570 27/37/54/75
WATSON & CHALIN	AS-0011
RIDEWELL	1003589082C

PLASTIC PISTON

7 KG.

P10.9083.C

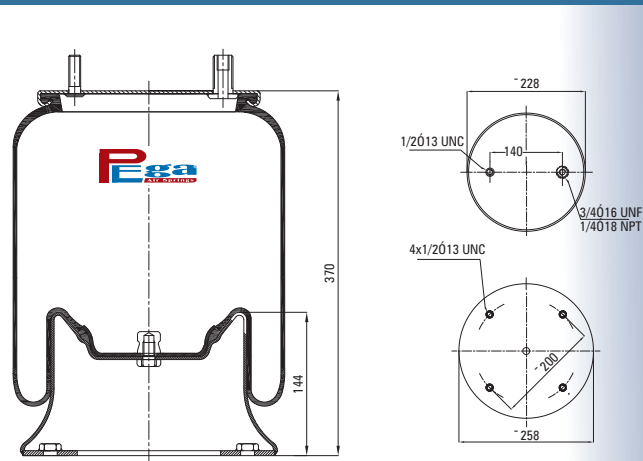

Cross References

CONTITECH	9 10-14 P 333
FIRESTONE	1T15M-6 W01 358 9083
GOOD YEAR	1R12-006

OE Part No

RIDEWELL	1003589083C
WATSON & CHALIN	AS-0028
HENDRICKSON TRAILER	S 1561

METAL PISTON

7 KG.

P10.9084.CP

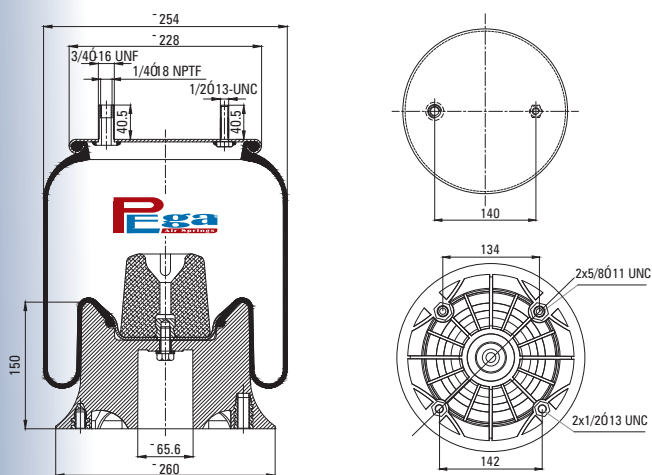

Cross References

FIRESTONE	W01-681-9084
-----------	--------------

OE Part No

GRANNING	2692/15690
----------	------------

PLASTIC PISTON

6,5 KG.

P10.9092.CP

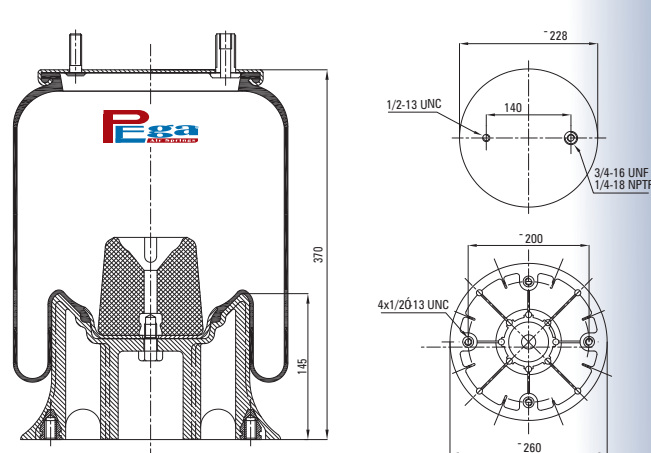

Cross References

CONTITECH	9 10-16 P 372
FIRESTONE	1T15M-6 W01 358 9092

OE Part No

SAF HOLLAND (NEWAY)	90557031
HENDRICKSON CANADA	S 12353

PLASTIC PISTON

6,8 KG.

P10.9093.CP

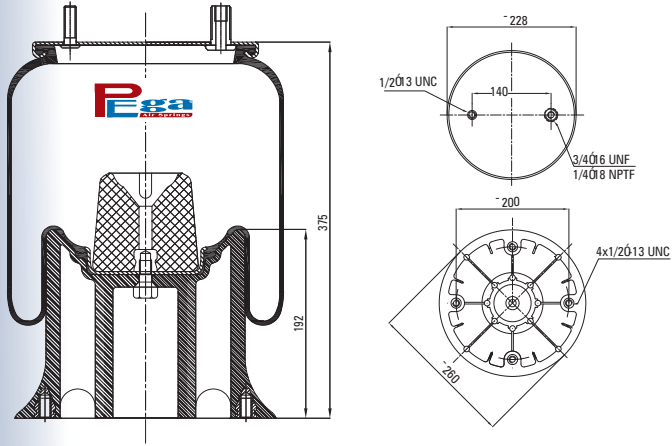

Cross References		OE Part No	
CONTITECH	9 10-16 P 332	SAF HOLLAND (NEWAY)	90557007
FIRESTONE	1T15M-6	SAF HOLLAND (NEWAY)	90557032
	W01 358 9093	SAF HOLLAND (NEWAY)	90557035

PLASTIC PISTON

7,5 KG.

P10.9096.CP

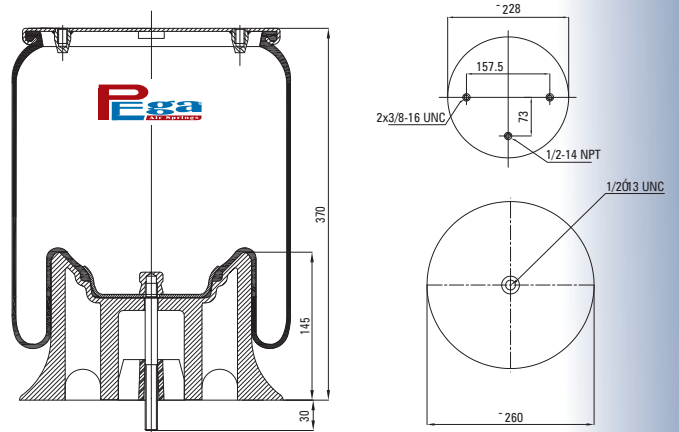

Cross References		OE Part No	
CONTITECH	9 10-16 P 325	HENDRICKSON	S-13049
FIRESTONE	1T15M-6	SAF HOLLAND	57009096
	W01 358 9096	LOADGUARD	SC2051
			SC2765

PLASTIC PISTON

7 KG.

P10.9104.CP

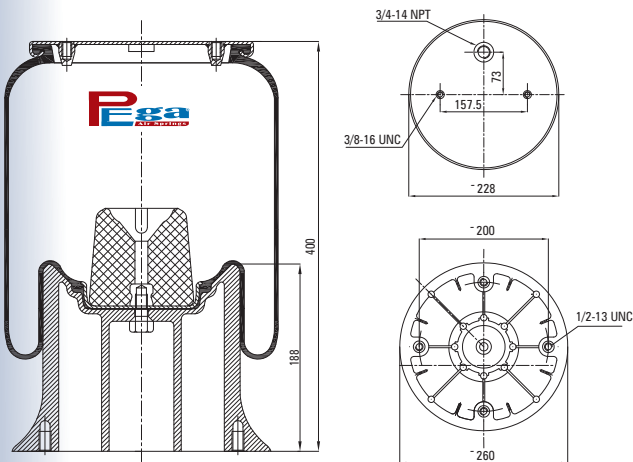

Cross References		OE Part No	
FIRESTONE	1T15M-9	SCANIA	255294
	W01 358 9104		

PLASTIC PISTON

7,5 KG.

P10.9121.CP

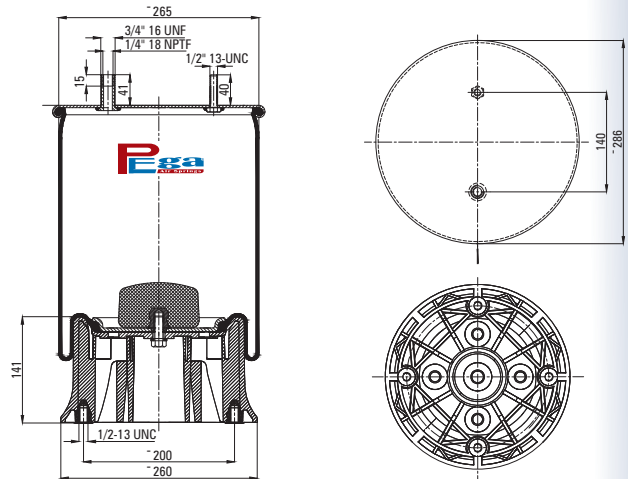

Cross References		OE Part No	
CONTITECH	4810 N03	NEWAY	90557 019
FIRESTONE	1T19L-7	NEWAY	90557 078
	W01 358 9121	NEWAY	90557 083
GOODYEAR	1R13-039	NEWAY	90557 052

PLASTIC PISTON

10 KG.

P10.9122.CP

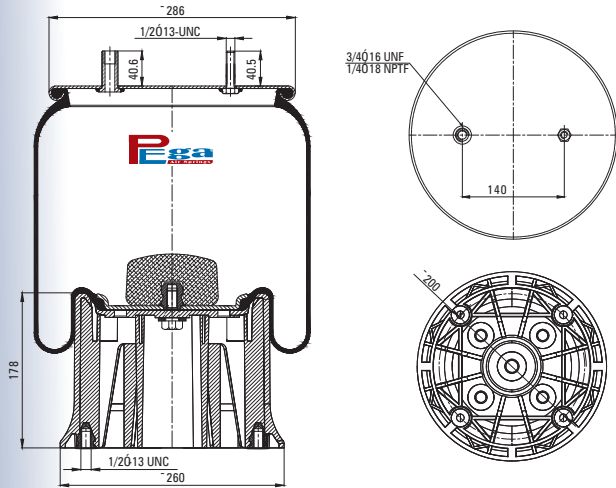

Cross References		OE Part No	
CONTITECH	4811 N03	NEWAY	90557 020
FIRESTONE	1T19L-11	NEWAY	90557 076
	W01 358 9122	NEWAY	90557 077
GOODYEAR	1R13-038	HENDRICKSON	S 3830

PLASTIC PISTON 10 KG.

P10.9130.CAL

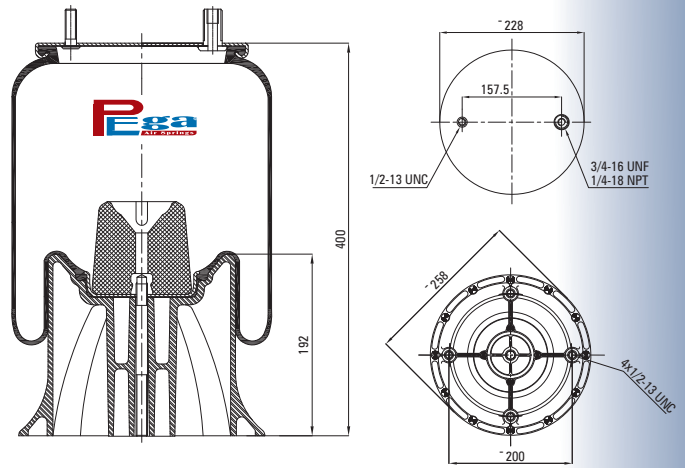

Cross References		OE Part No	
CONTITECH	9 10-16 P 321	HENDRICKSON	S-13161
FIRESTONE	1T15M-9		
	W01 358 9130		

ALUMINIUM PISTON 12 KG.

P10.9141.C

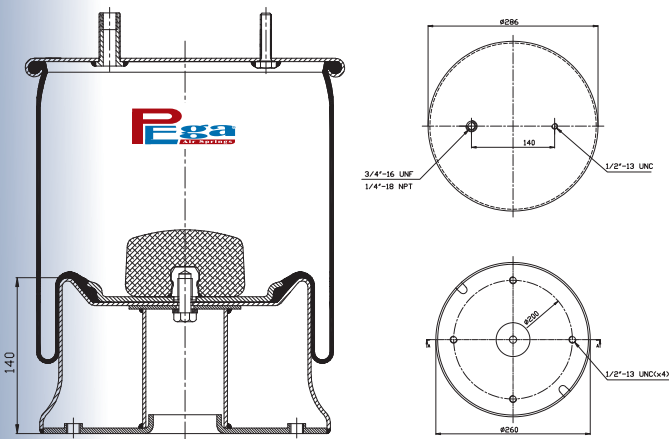

Cross References		OE Part No	
FIRESTONE	W013589141	SAF HOLLAND	90557110
GOODYEAR	1R14-215		

METAL PISTON 12 KG.

P10.9141.CP

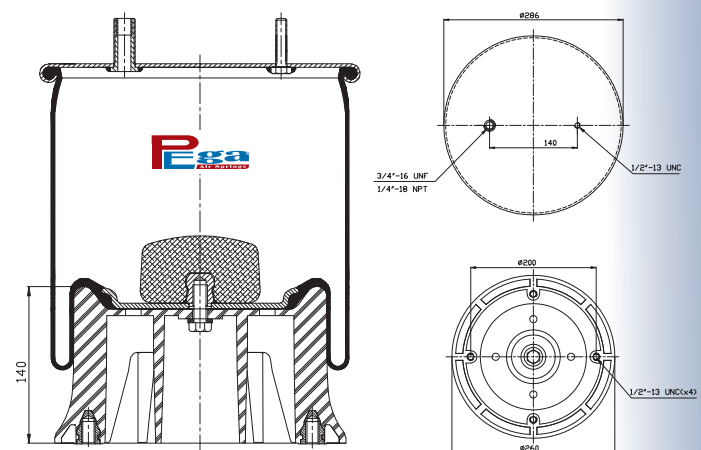

Cross References		OE Part No	
FIRESTONE	W013589141	SAF HOLLAND	90557110
GOODYEAR	1R14-215		

PLASTIC PISTON 8,6 KG.

P10.9156.CP

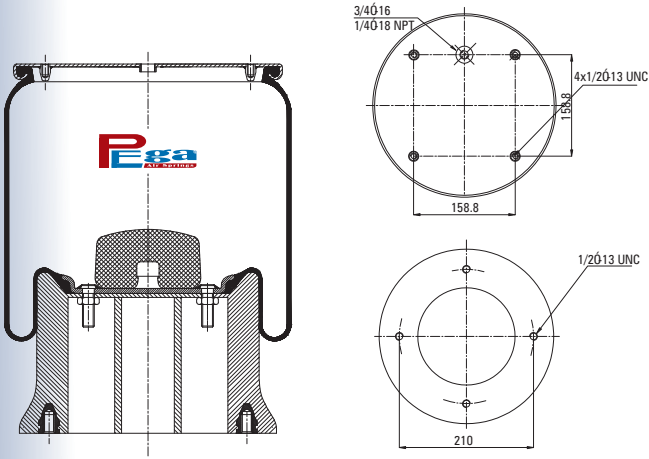

Cross References

CONTITECH	11 10.5-21 A 370
FIRESTONE	1T19L-11
	W01 358 9156
GOODYEAR	1R14-019

OE Part No

HENDRICKSON	S 7128
-------------	--------

PLASTIC PISTON

9 KG.

P10.9158.CP

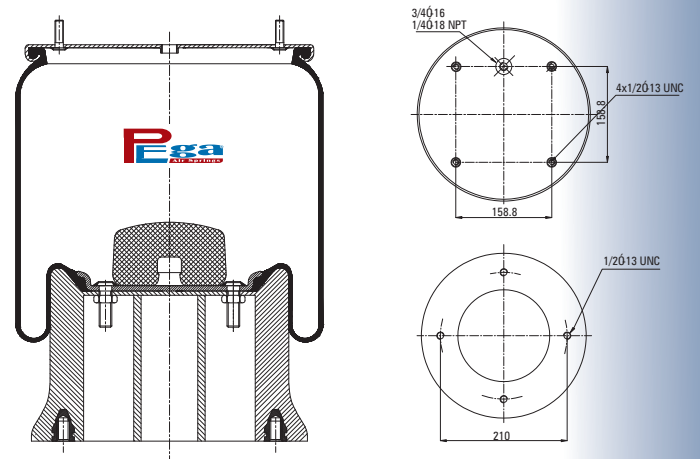

Cross References

CONTITECH	11 10.5-21 A 318
FIRESTONE	1T19F-11
	W01 358 9158

OE Part No

SAF HOLLAND (NEWAY)	90557005
	90557069
HENDRICKSON TRAILER	S 2063
RIDEWELL	1003589158C
HENDRICKSON CANADA	B-12514-004
	B-12514-011

PLASTIC PISTON

9 KG.

P10.9192.CP

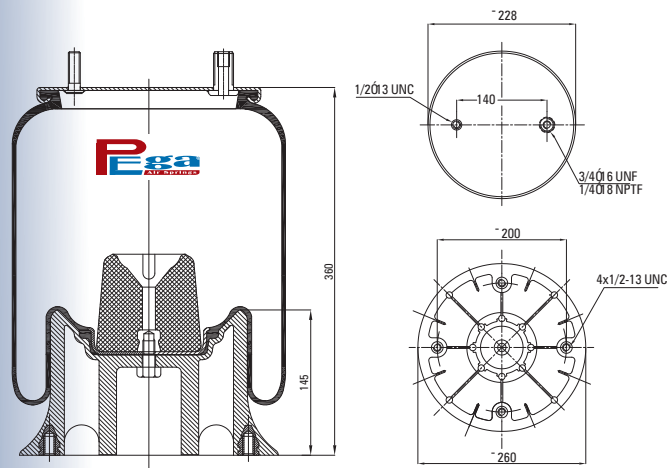

Cross References

CONTITECH	9 10-19 P 326
FIRESTONE	1T15M-9
	W01 358 9192

OE Part No

HENDRICKSON TRAILER	S 6195
WATSON&CHALIN	AS-0038&AS-0046
SAF HOLLAND NEWAY)	90557086,108

PLASTIC PISTON

6 KG.

P10.9193.CP

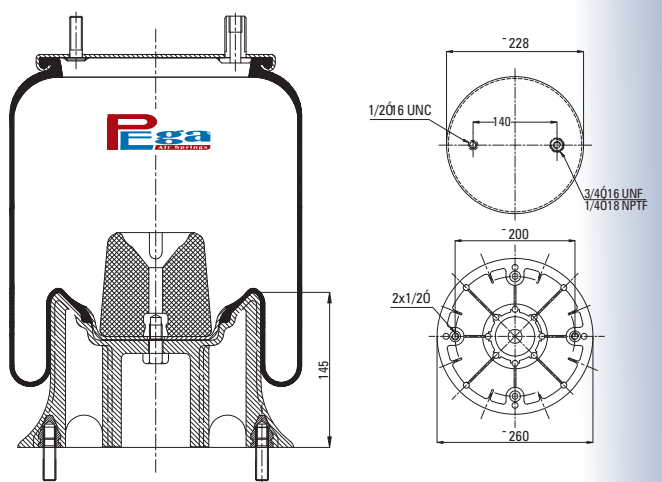

Cross References

CONTITECH	9 10-14 P 351
FIRESTONE	1T15M-6
	W01 358 9193

OE Part No

SAF HOLLAND (NEWAY)	90557101
---------------------	----------

PLASTIC PISTON

6 KG.

P10.9203.CP

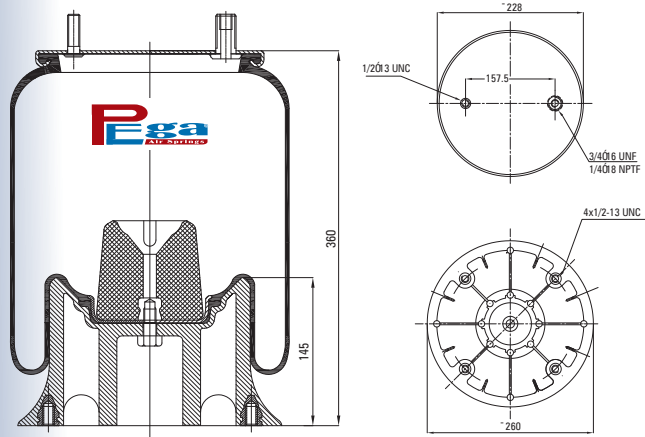

Cross References

CONTITECH	9 10-19 P 355
FIRESTONE	1T15M-9
	W01 358 9203

OE Part No

HENDRICKSON TRAILER	S 2694
---------------------	--------

PLASTIC PISTON

6 KG.

P10.9213.CP

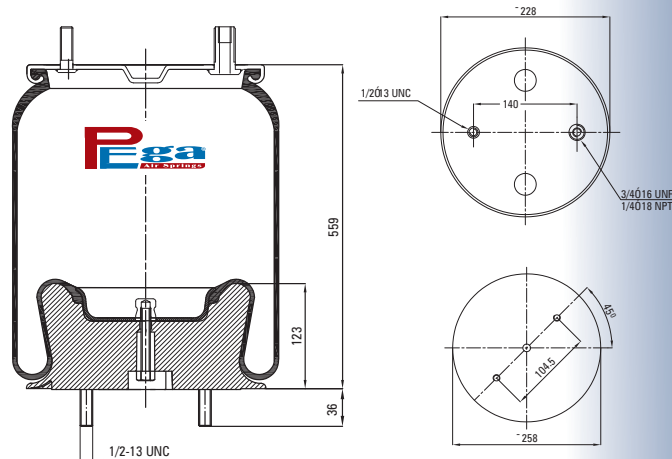

Cross References

CONTITECH	9 10-16 P 441
FIRESTONE	1T15M-6
	W01 358 9213
GOODYEAR	1R12-090

OE Part No

NAVISTAR	501559C-1
NAVISTAR	501559C-2
NAVISTAR	1660581C-1

PLASTIC PISTON

5,8 KG.

P10.9219.CP

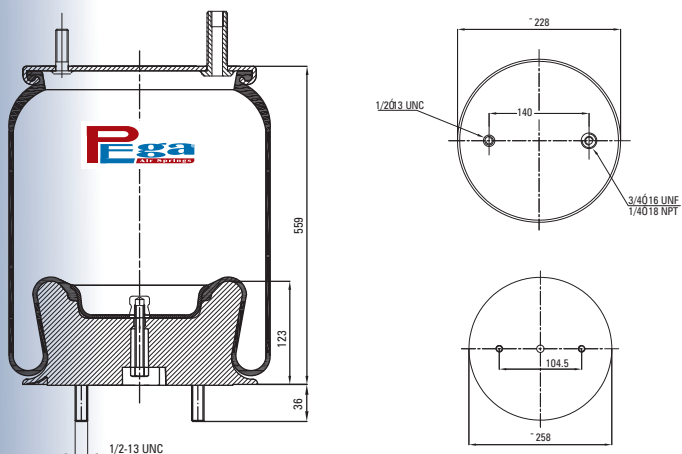

Cross References

CONTITECH	9 10-16 P 408
FIRESTONE	1T15M-6
	W01 358 9219

OE Part No

VOLVO	35003-3201
VOLVO	35203-3203
VOLVO	35003-3204
VOLVO	35003-3209

PLASTIC PISTON

6 KG.

P10.9227.CP

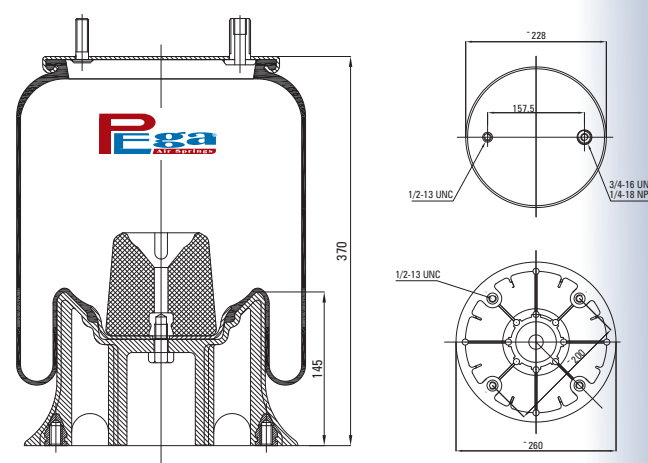

Cross References

CONTITECH	9 10-16 P 353
FIRESTONE	1T15M-6
	W01 358 9227

OE Part No

HENDRICKSON TRAILER	S 2924
---------------------	--------

PLASTIC PISTON

7 KG.

P10.9238.CAL

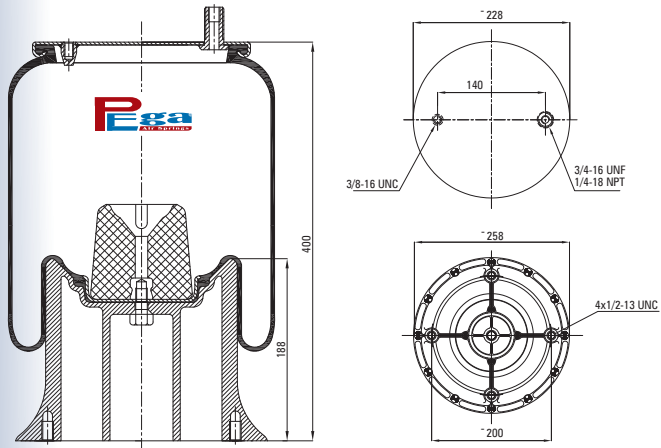

Cross References	
CONTITECH	9 10-19 A 356
FIRESTONE	1T15M-9
	W01 358 9238

OE Part No	
HENDRICKSON TRAILER	S 5060

ALUMINIUM PISTON

9 KG.

P10.9238.CP

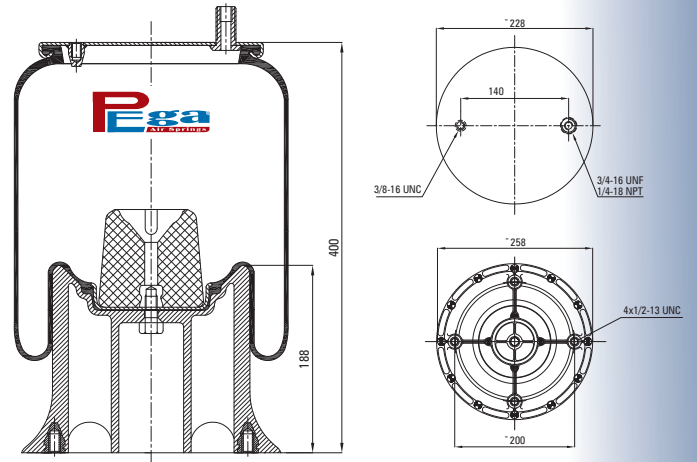

Cross References	
CONTITECH	9 10-19 P 356
	1T15M-9
	W01 358 9238

OE Part No	
HENDRICKSON TRAILER	S 5060

PLASTIC PISTON

8 KG.

P10.9240.CAL

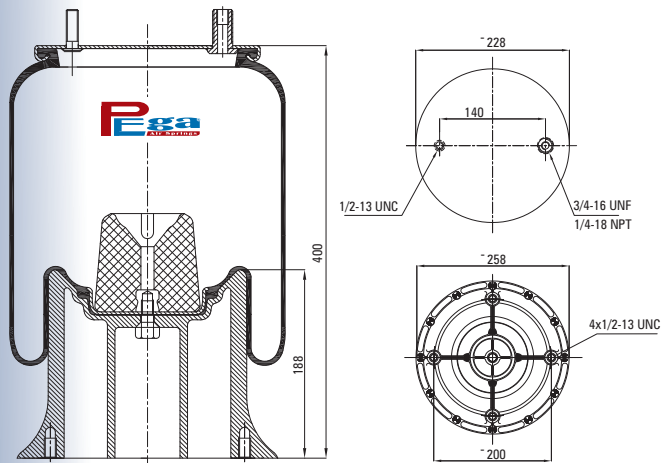

Cross References	
CONTITECH	9 10-19 A 357
FIRESTONE	1T15M-9
	W01 358 9240

OE Part No	
HENDRICKSON TRAILER	S 3842
HENDRICKSON CANADA	S 10352

ALUMINIUM PISTON

9 KG.

P10.9240.CP

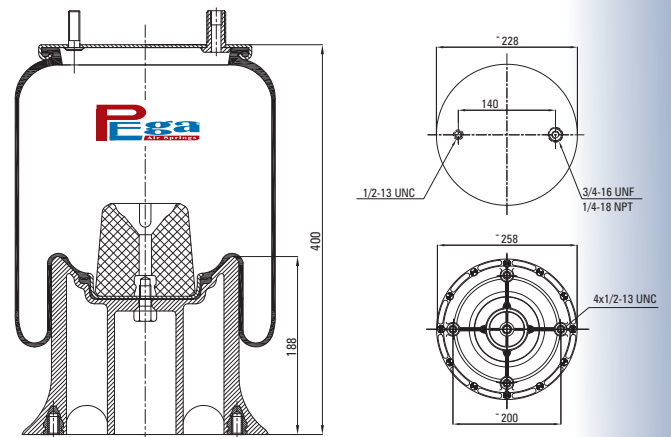

Cross References	
CONTITECH	9 10-19 P 357
FIRESTONE	1T15M-9
	W01 358 9240

OE Part No	
HENDRICKSON TRAILER	S 3842
HENDRICKSON CANADA	S 10352

PLASTIC PISTON

8 KG.

P10.9241.CAL

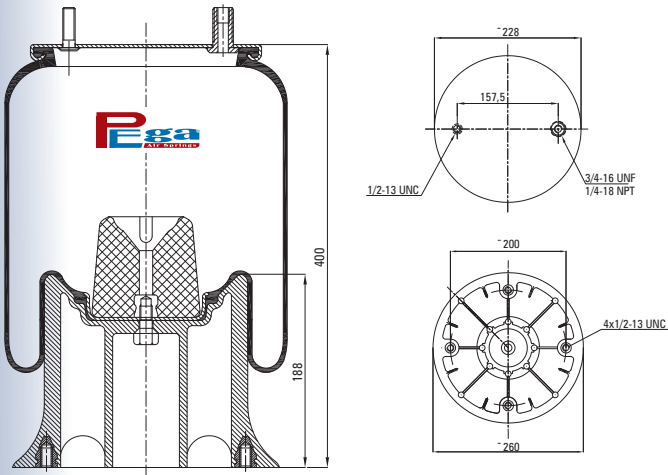

Cross References

CONTITECH 9 10-16 P 358
 FIRESTONE 1T15M-9
 W01 358 9241

OE Part No

HENDRICKSON S-10352

ALUMINIUM PISTON

9 KG.

P10.9241.CP

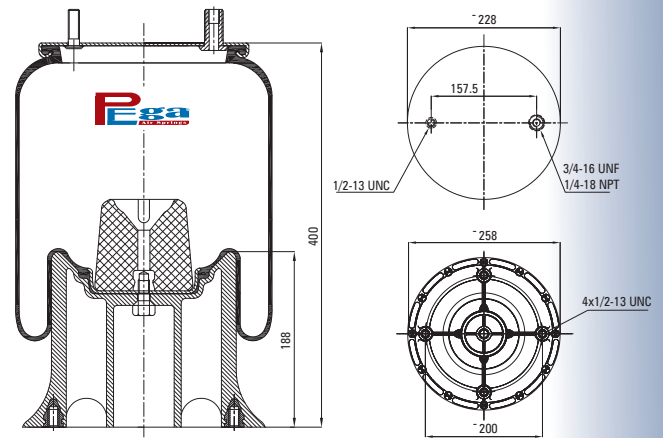

Cross References

CONTITECH 9 10-16 P 358
 FIRESTONE 1T15M-9
 W01 358 9241

OE Part No

HENDRICKSON S-10352

PLASTIC PISTON

8 KG.

P10.9243.CP

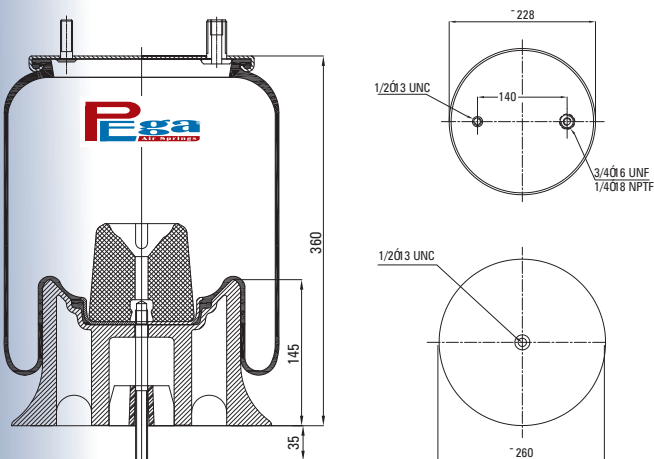

Cross References

CONTITECH 9 10-19 P 384
 FIRESTONE 1T15M-9
 W01 358 9243

OE Part No

SAF HOLLAND (NEWAY) 900557112
 WATSON & CHALIN AS-0061

PLASTIC PISTON

7 KG.

P10.9245.CP

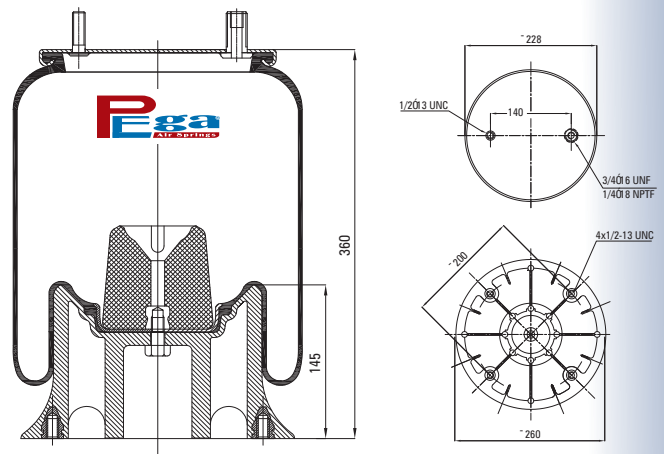

Cross References

CONTITECH 9 10-19 P 390
 FIRESTONE 1T15M-9
 W01 358 9245

OE Part No

RIDEWELL 1003589245C

PLASTIC PISTON

7,4 KG.

P10.9265.C

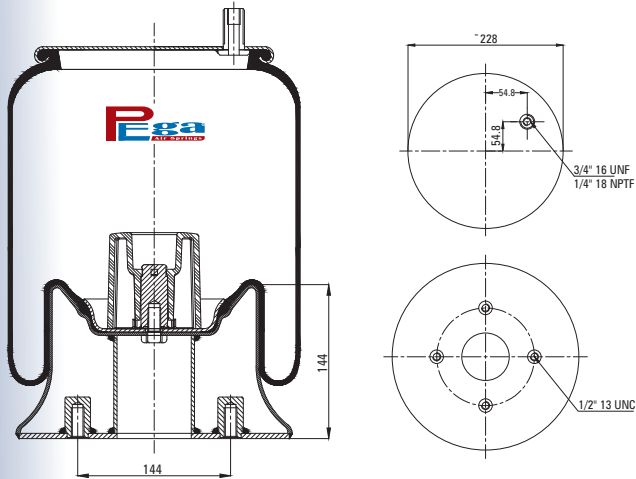

Cross References		OE Part No	
CONTITECH	9 10-19 P 435	HENDRICKSON TRAILER	S 20124
FIRESTONE	1T15MM-9	HENDRICKSON TRAILER	HT-250 T
	W01 358 9265	HENDRICKSON TRAILER	C 20413
GOODYEAR	1R12-375	HENDRICKSON TRAILER	HT-250 U
		HENDRICKSON TRAILER HT-250 U-Y(9Y-001)	
		VOLVO	85 101 155
		RIDEWELL	100 358 9245C
		LOADGUARD	SC 2759

METAL PISTON 9 KG.

P10.9270.C

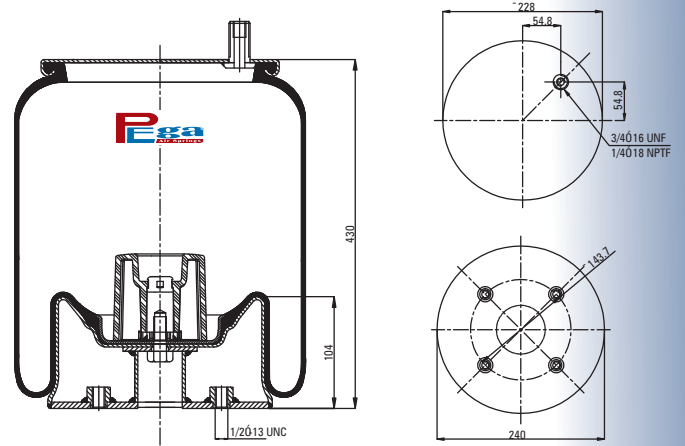

Cross References		OE Part No	
CONTITECH	9 10-13.5 S 433	HENDRICKSON	C 20010
FIRESTONE	1T15VP-4	HENDRICKSON	C 200108
	W01 358 9270	HENDRICKSON	C 21208
GOODYEAR	1R13-119	HENDRICKSON	C 25559
		VOLVO	85 101 147
		WATSON & CHALIN	AS-0084

METAL PISTON 10 KG.

P10.9270.C01

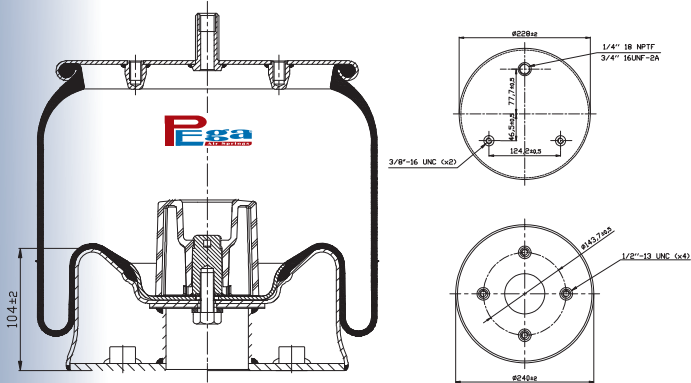

Cross References		OE Part No	
FIRESTONE	1T15VP-4	HENDRICKSON	C 20010
	W01 358 9270	HENDRICKSON	C 200108
GOODYEAR	1R13-119	HENDRICKSON	C 21208
		HENDRICKSON	C 25559
		VOLVO	85 101 147
		WATSON & CHALIN	AS-0084

METAL PISTON 10 KG.

P10.9270.CP

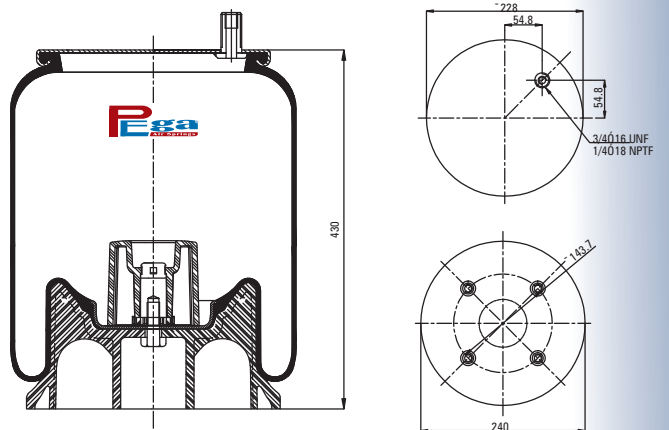

Cross References		OE Part No	

PLASTIC PISTON 7 KG.

P10.9287.CP

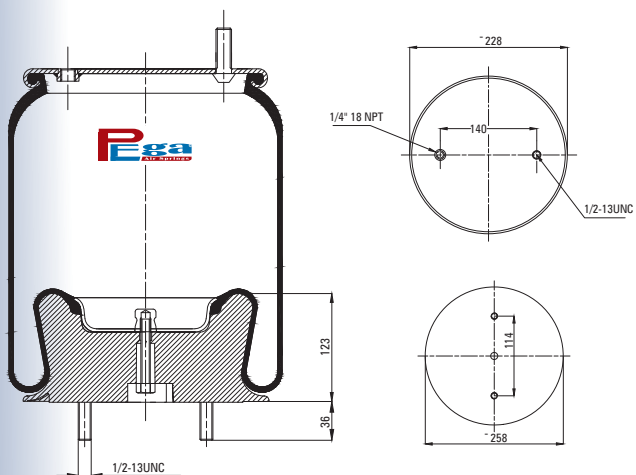

Cross References	
CONTITECH	9 10-18.5 P 406
FIRESTONE	1T15M-8
	W01 358 9287

OE Part No	
HENDRICKSON	50405-1 & 2

PLASTIC PISTON

7,5 KG.

P10.9293.CP

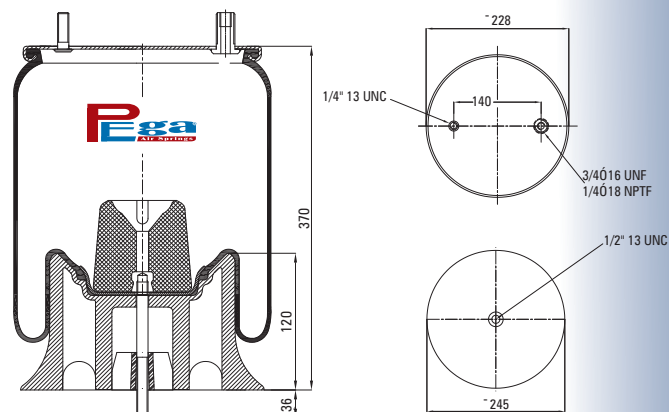

Cross References	
CONTITECH	9 9K-15 P 424
FIRESTONE	1T15LP-5
	W01 358 9293
GOOD YEAR	1R10-120

OE Part No	
SAF HOLLAND (NEWAY)	90557120

PLASTIC PISTON

5,6 KG.

P10.9294.CP

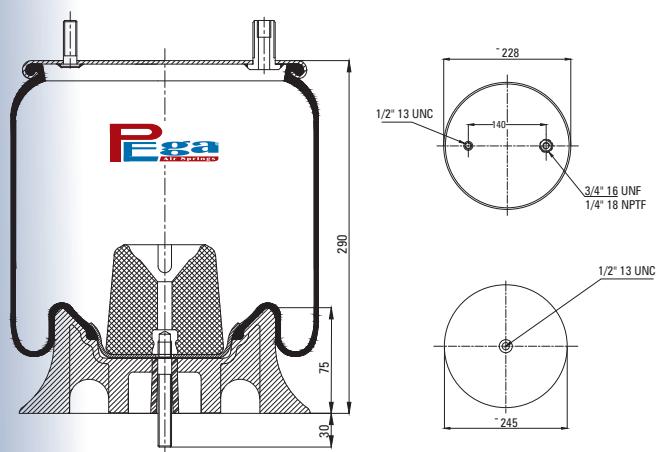

Cross References	
CONTITECH	9 9K-75 P 423
FIRESTONE	1T15LP-5
	W01 358 9294

OE Part No	
SAF HOLLAND (NEWAY)	90557127

PLASTIC PISTON

5 KG.

P10.9296.CP

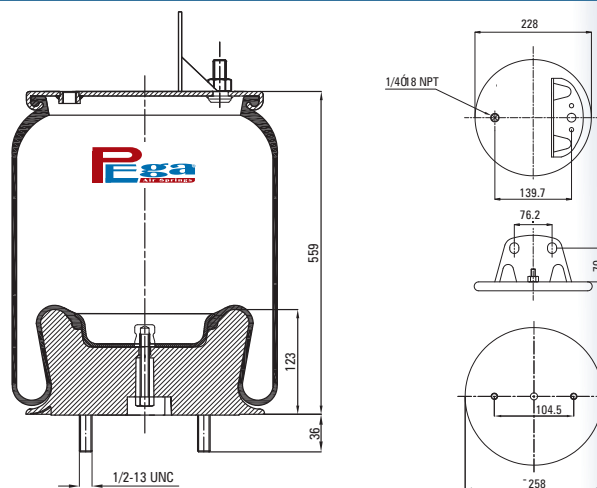

Cross References	
CONTITECH	9 10-16 P 416
FIRESTONE	1T15M-6
	W01 358 9296

OE Part No	
VOLVO/GM	8061151
	8169868

PLASTIC PISTON

6 KG.

P10.9304.CP

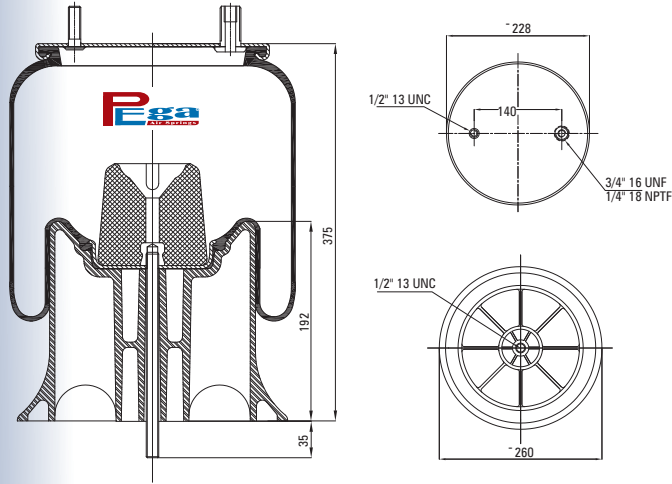

Cross References

CONTITECH	9 10-16 P 392
FIRESTONE	1T15M-6
	W01 358 9304
	W01 358 9364
	8392

OE Part No

SAF HOLLAND	90557124
WATSON & CHALIN	AS-0059

PLASTIC PISTON

7,5 KG.

P10.9320.CP

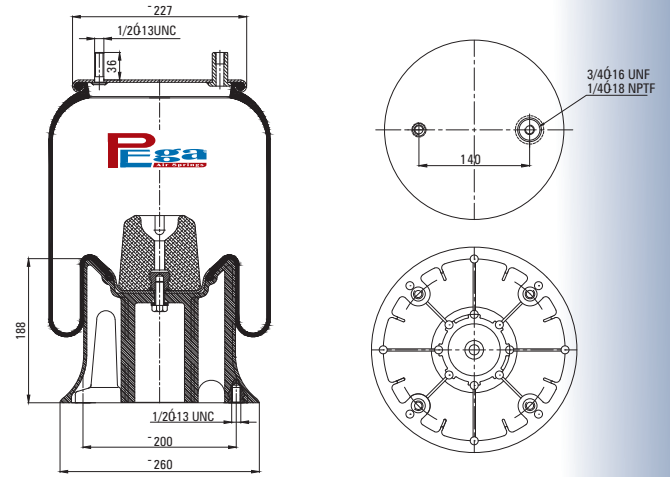

Cross References

CONTITECH	9 10-21 P 360
FIRESTONE	1T15M-11
	W01 358 9320
GOODYEAR	1R12-363

OE Part No

SAF HOLLAND (NEWAY)	90557 099
LOADGUARD	SC 2774

PLASTIC PISTON

7,6 KG.

P10.9321.CP

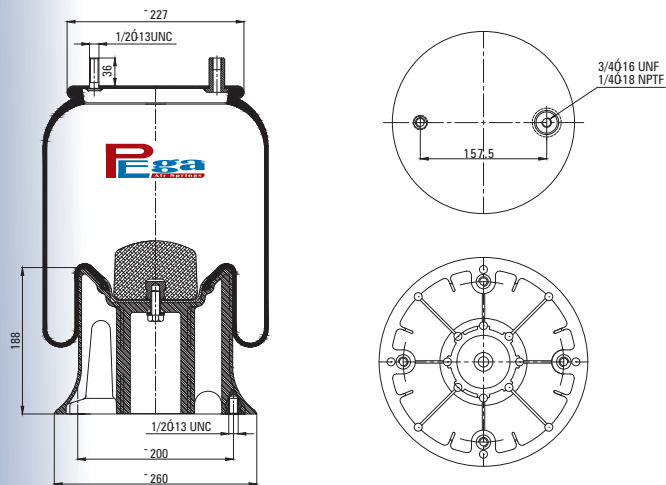

Cross References

CONTITECH	9 10-21 P 361
FIRESTONE	1T15M-11
	W01 358 9321
GOODYEAR	1R12-256

OE Part No

WATSON & CHALIN	AS-0036
LOADGUARD	SC 2120
SAF HOLLAND	57009321
VOLVO	85101160
HENDRICKSON	B-14249

PLASTIC PISTON

7,6 KG.

P10.9335.CP

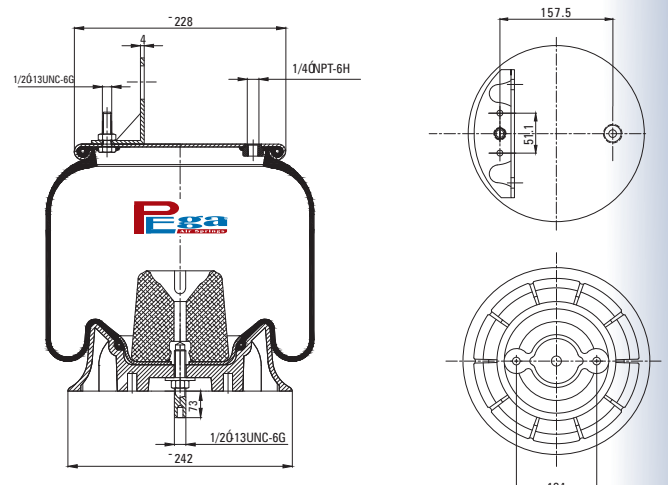

Cross References

CONTITECH	9 10-10 P 465
FIRESTONE	1T15M-4
	W01 358 9335
GOODYEAR	1R12-620

OE Part No

HENDRICKSON	56917-1 & 2 (CLASS 6 & 7 FREIGHTLINER) REF.56916 (W01-358-9284) SUPERSEDED
-------------	--

PLASTIC PISTON

5 KG.

P10.9342.CP

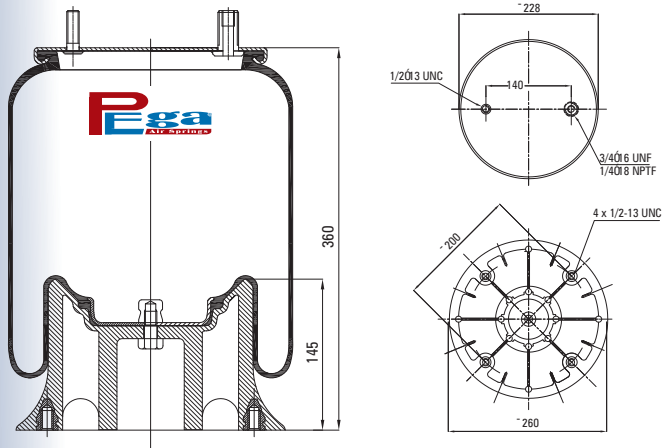

Cross References	
CONTITECH	9 10-17.5 P 418
FIRESTONE	1T15M-9 W01 358 9342
GOODYEAR	1R12-450

OE Part No	

PLASTIC PISTON

6 KG.

P10.9348.CP

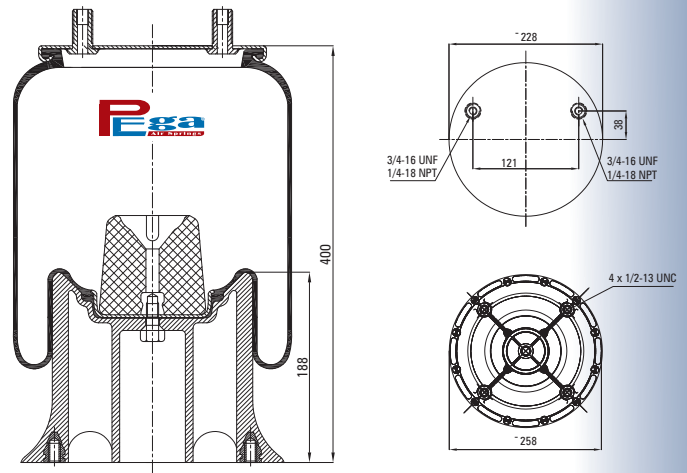

Cross References	
CONTITECH	9 10-19 P 439
FIRESTONE	1T15M-9 W01 358 9348

OE Part No	
LOADGUARD	S 8988
SAF HOLLAND	57009348

PLASTIC PISTON

7,5 KG.

P10.9349.CP

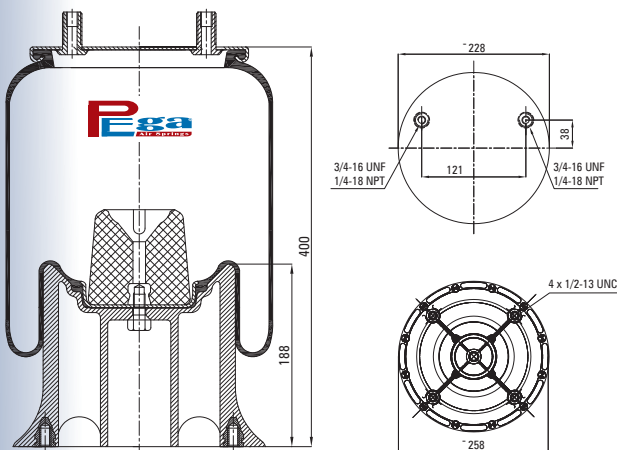

Cross References	
CONTITECH	9 10-19 P 438
FIRESTONE	1T15M-9 W01 358 9349

OE Part No	
HENDRICKSON TRAILER	S 8988
REYCO	17636-01

PLASTIC PISTON

8 KG.

P10.9350.CP

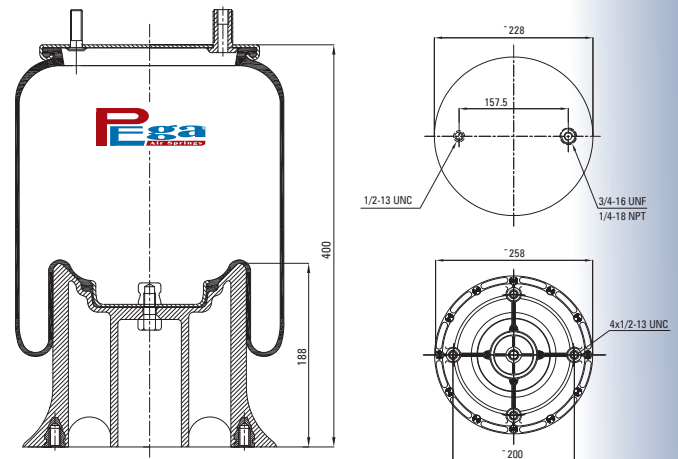

Cross References	
CONTITECH	9 10-19 P 359
FIRESTONE	1T15M-9 W01 358 9350

OE Part No	

PLASTIC PISTON

7 KG.

P10.9367.C

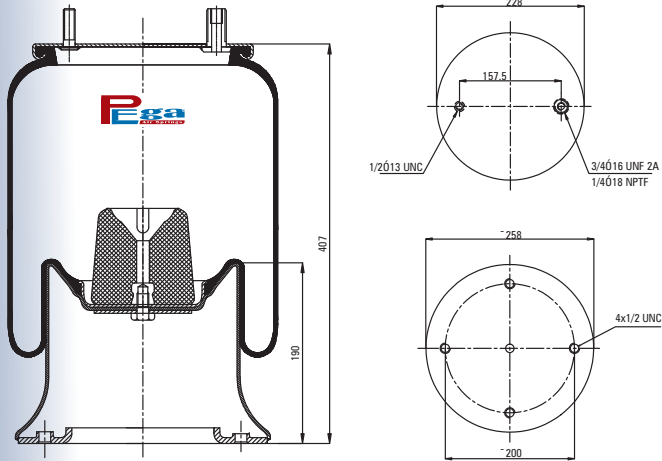

Cross References

CONTITECH	9 10-21 P 505
FIRESTONE	1T15M-11 W01 358 9367
GOODYEAR	1R12-256

OE Part No

HENDRICKSON	S 14249
HENDRICKSON	003319 (METRIC)

METAL PISTON

11,5 KG.

P10.9367.CAL

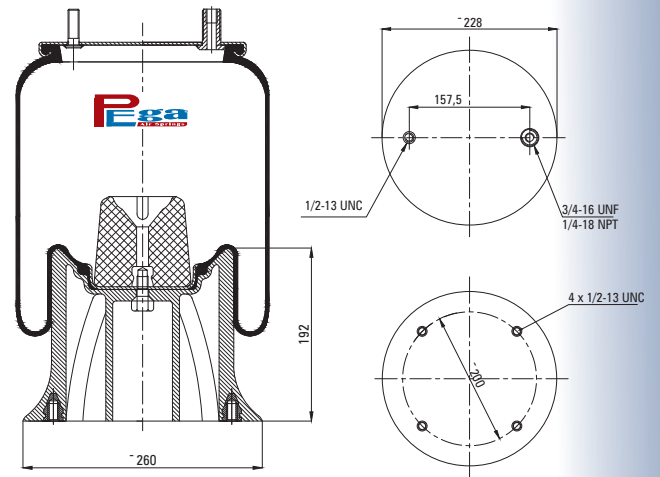

Cross References

CONTITECH	9 10-21 A 505
-----------	---------------

OE Part No

SAF HOLLAND (NEWAY)	S 142249
LOADGUARD	SC 2120
HENDRICKSON	B-14249 003319 B-4375
WATSON & CHALIN	AS-0104

ALUMINIUM PISTON

10 KG.

P10.9370.CP

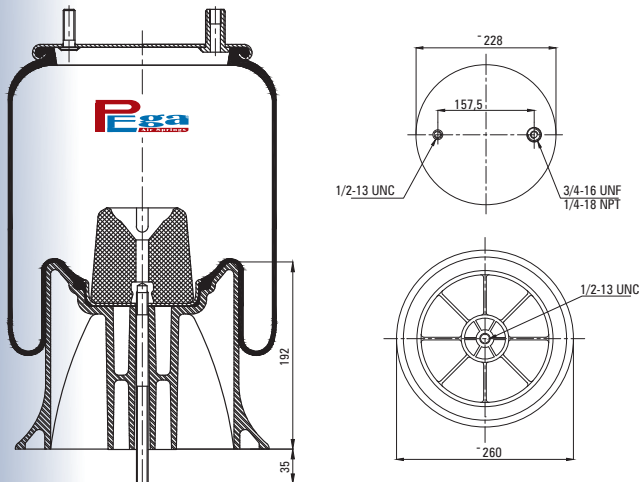

Cross References

CONTITECH	9 10-21 P 448
FIRESTONE	1T15M-11 W01 358 9370
GOODYEAR	1R12-580 / 1R12-503

OE Part No

WATSON & CHALIN	AS-0057
-----------------	---------

PLASTIC PISTON

7,5 KG.

P10.9371.CP

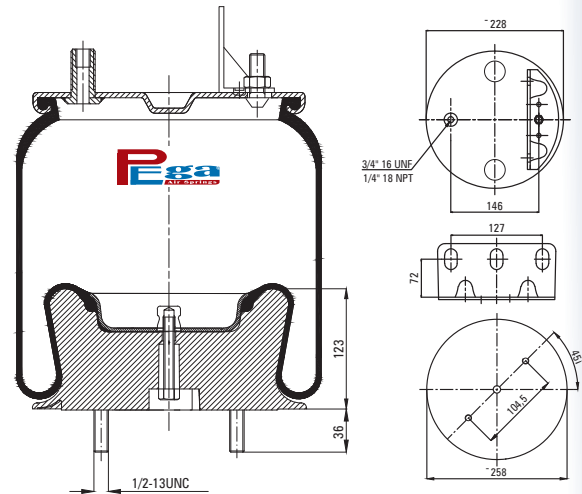

Cross References

CONTITECH	9 10-17.5 P 521
FIRESTONE	1T15M-8 W01 358 9371
GOODYEAR	1R12-401

OE Part No

NAVISTAR	1670073C-1
NAVISTAR	1686386C-1
NAVISTAR	2027911C1

PLASTIC PISTON

6,3 KG.

P10.9373.CP

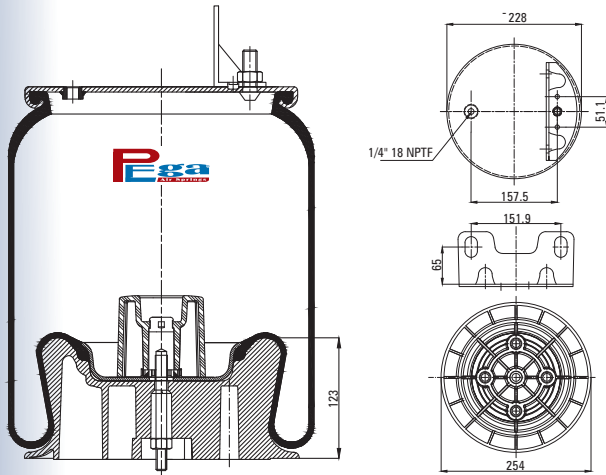

Cross References

CONTITECH	9 10-18.5 P 519
FIRESTONE	1T15MT-8 W01 358 9373
GOODYEAR	1R12-403

OE Part No

HENDRICKSON	57122-1
	57122-2

PLASTIC PISTON

7,4 KG.

P10.9375.CP

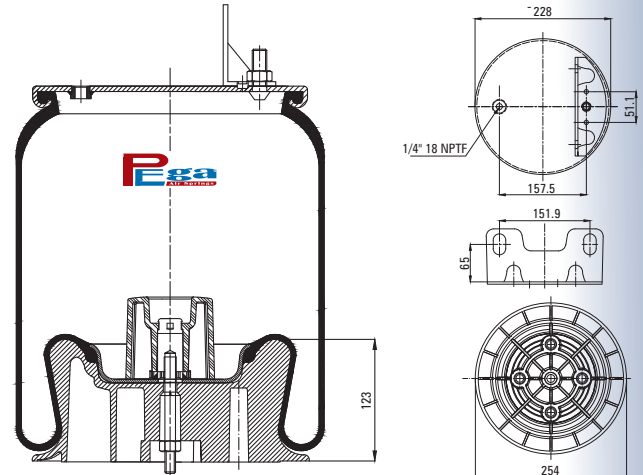

Cross References

CONTITECH	9 10.1-75 P 451
FIRESTONE	1T15M-8 W01 358 9375
GOODYEAR	1R12-404
GOODYEAR	1R12-488

OE Part No

HENDRICKSON	50899-1
HENDRICKSON	50899-2
LOADGUARD	SC2773
MACK	364SQ27
MACK	57QL414M

PLASTIC PISTON

7,4 KG.

P10.9391.CP

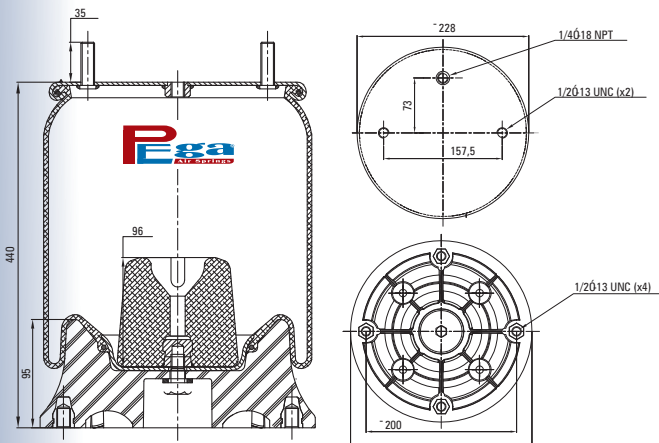

Cross References

FIRESTONE	1T15L4 W01 358 9391
-----------	------------------------

OE Part No

SCANIA	ST10078295
--------	------------

PLASTIC PISTON

5,8 KG.

P10.9392.CP

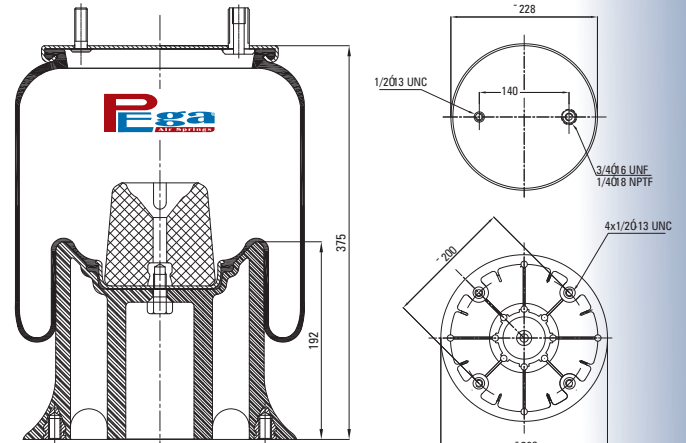

Cross References

CONTITECH	9 10-16 P 376
FIRESTONE	1T15M-6 W01 358 9392

OE Part No

HENDRICKSON TRAILER	S 4773
---------------------	--------

PLASTIC PISTON

7,5 KG.

P10.9394.CP

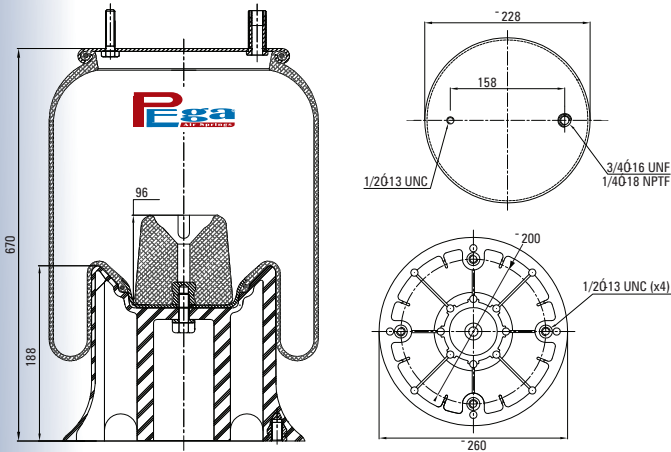

Cross References	
CONTITECH	9 10-19 P 358
FIRESTONE	1T15M9 W013589394
GOODYEAR	1R12-279

OE Part No	
HENDRICKSON	S-10352
WATSON & CHALIN	AS-0142

PLASTIC PISTON

6 KG.

P10.9422.CP

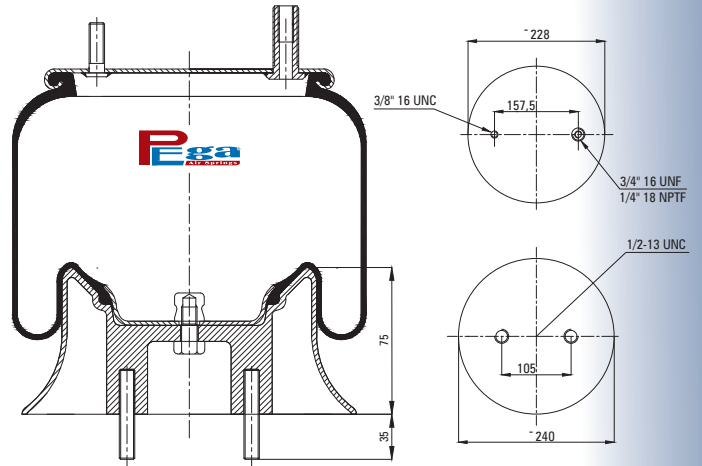

Cross References	
CONTITECH	9 9-12 P 314
FIRESTONE	1T15L-15 W01 358 9422
GOODYEAR	1R11-028

OE Part No	
HENDRICKSON	B-13032
KENWORTH	K-303-6 K-303-14 K-303-15
LOADGUARD	SC 2050
VOLVO	85101148
WATSON & CHALIN	AS-0017

PLASTIC PISTON

4,5 KG.

P10.9463.CP

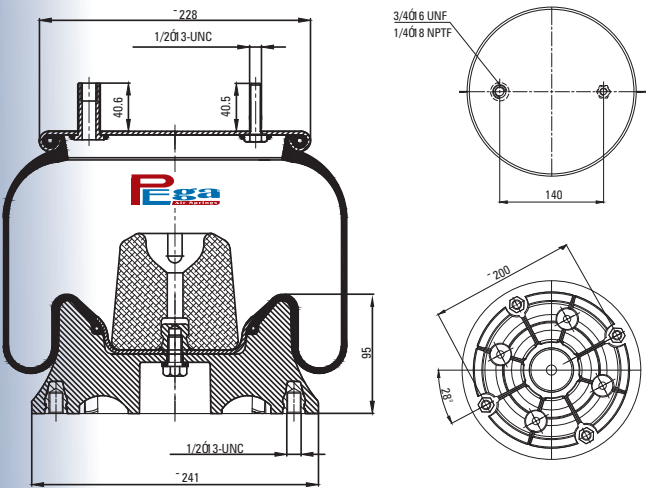

Cross References	
CONTITECH	9 10-14 A 437
FIRESTONE	1T1M-4 W01 358 9463

OE Part No	
SAF HOLLAND	90557130-RH
SAF HOLLAND	90557131-LH

PLASTIC PISTON

5,7 KG.

P10.9466.CP

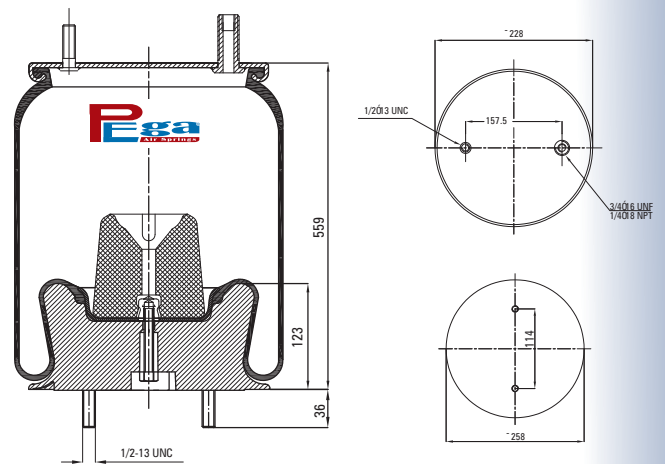

Cross References	
CONTITECH	9 10-16 P 410
FIRESTONE	1T15M-6 W01 358 9466

OE Part No	
HENDRICKSON (FORD)	49048
HENDRICKSON (FORD)	49674-1 & 2
HENDRICKSON (FORD)	49250

PLASTIC PISTON

6,5 KG.

P10.9471.CP

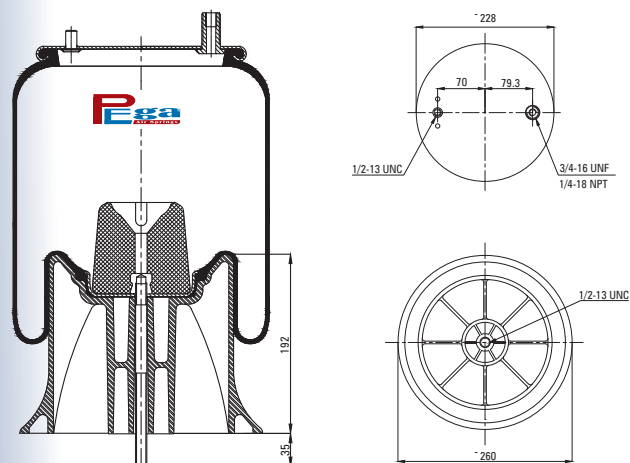

Cross References	
CONTITECH	9 10-17.5 P 502
FIRESTONE	1T15V-8 W01 358 9471
GOOD YEAR	1R12-504

OE Part No	
SAF HOLLAND (NEWAY)	90557146
	90557182
	90557177

PLASTIC PISTON

7,5 KG.

P10.9482.CP

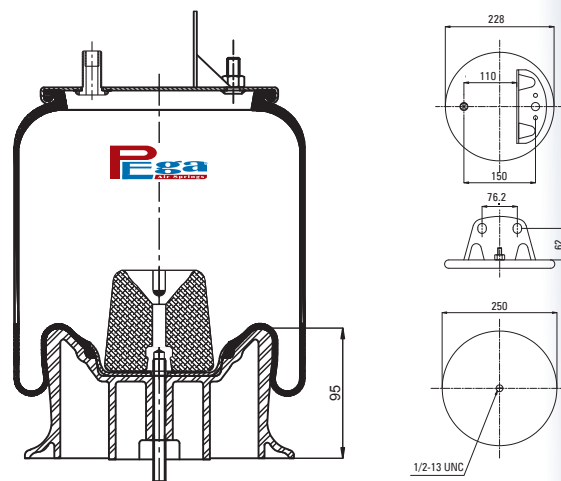

Cross References	
CONTITECH	9 10-14 P 492
FIRESTONE	1T15M-4 W01 358 9482

OE Part No	
SAF HOLLAND (NEWAY)	90557161

PLASTIC PISTON
WITH BRACKET

5,5 KG.

P10.9579.C

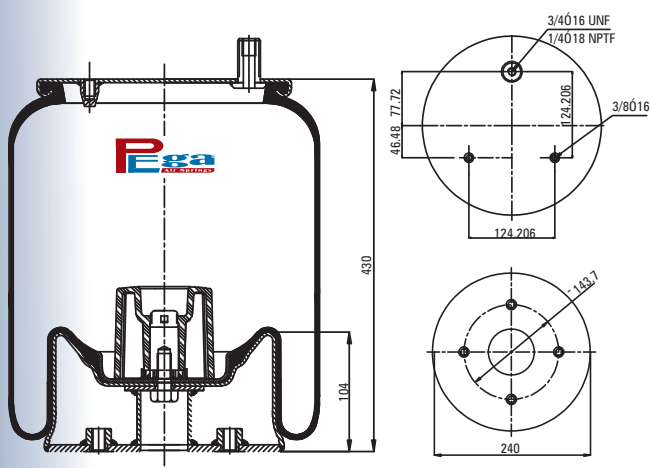

Cross References	
CONTITECH	9 10-13.5 S 881
FIRESTONE	1T15VP-4 W01 358 8800 W01 358 9579
GOODYEAR	1R13-119

OE Part No	
HENDRICKSON	S-21208

METAL PISTON

8,5 KG.

P10.9580.C

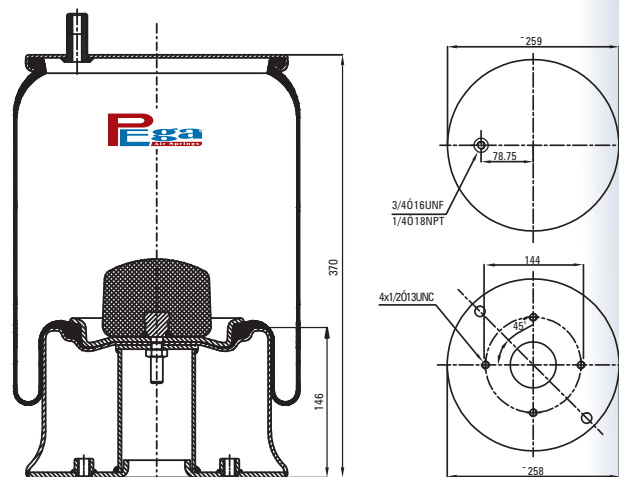

Cross References	
CONTITECH	10 10-21 S 434
FIRESTONE	1T15VLT105 W01 358 9262 W01 358 9580
GOODYEAR	1R13-081
GOODYEAR	1R13-118

OE Part No	
HENDRICKSON	S-20127
LOADGUARD	SC2761

METAL PISTON

7 KG.

P10.9648.CP

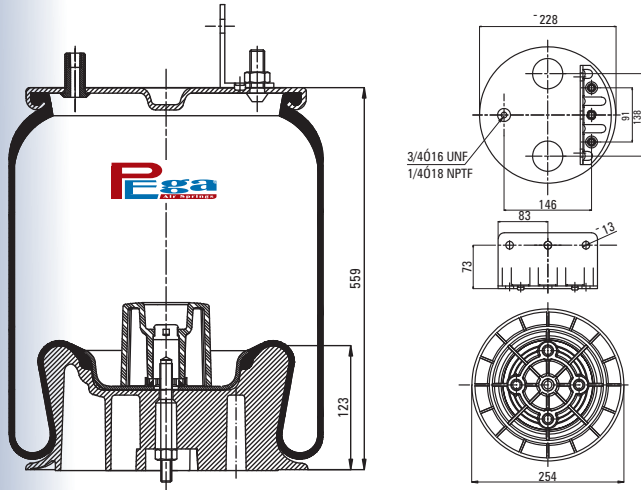

Cross References	
CONTITECH	9 10-18.5 P 456
FIRESTONE	1T15M-8 W01 358 9648
TAURUS	6363
GOODYEAR	1R12-398

OE Part No	
NAVISTAR/FLEETRITE	2027911C1
NAVISTAR/FLEETRITE	2027911C2
NAVISTAR/FLEETRITE	2027911C3

PLASTIC PISTON
WITH BRACKET

6,1 KG.

P10.9649.CP

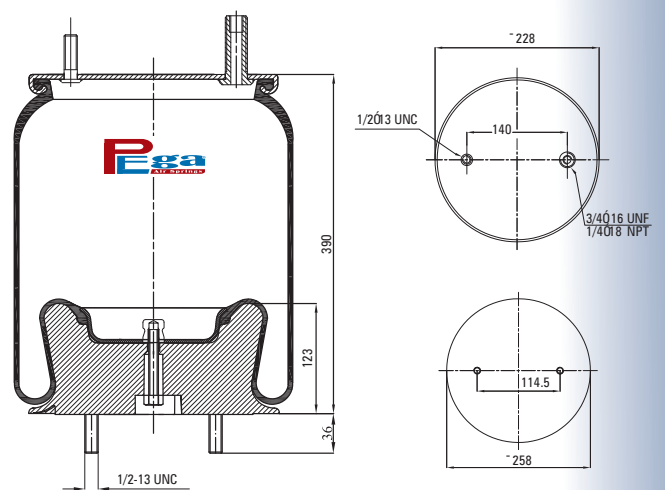

Cross References	
FIRESTONE	1T15M-8 W01 358 9649
CONTITECH	9 10-18.5 P 551

OE Part No	
SAF HOLLAND	90557252

PLASTIC PISTON

6,5 KG.

P10.9780.ALU

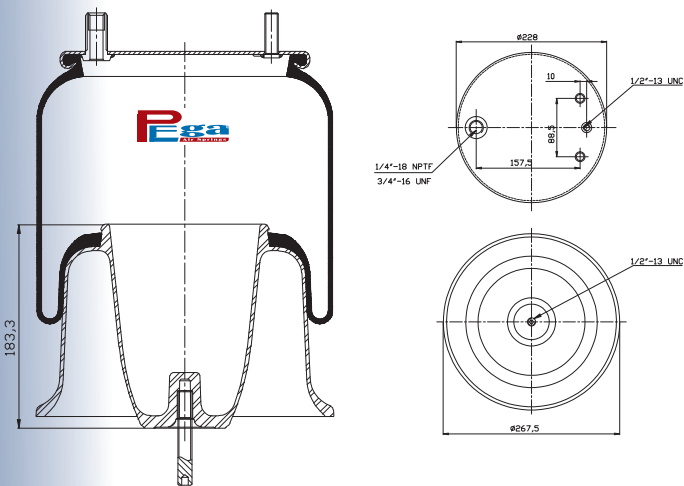

Cross References	
CONTITECH	9 10 S-16 A 382
FIRESTONE	1T15ZR-6 W01 358 9781

OE Part No	
FREIGHTLINER	681-320-0017

ALUMINIUM PISTON

10 KG.

P10.9780.C

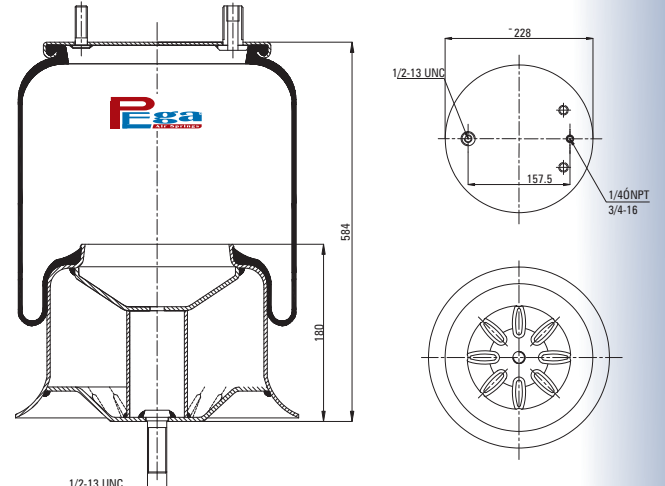

Cross References	
CONTITECH	9 10 S-16 A 382
FIRESTONE	1T15ZR-6 W01 358 9782

OE Part No	
FREIGHTLINER	16-16773-000

METAL PISTON

9 KG.

P10.9780.CP

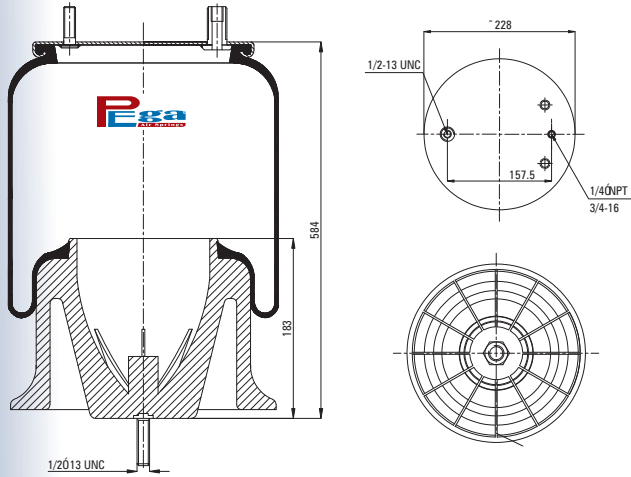

Cross References		OE Part No	
CONTITECH	9 10S-16 P 382	FREIGHTLINER	16-15595-000
FIRESTONE	1T15ZR6		16-14004-000
	W01 358 9780		16-13840-000
GOODYEAR	1R12-303		A16-14004-000
			681-320-0017
			16-13810-000
			16-1673-000
		LOADGUARD	SC2750
		VOLVO	85101151

PLASTIC PISTON

8,5 KG.

P10.9935.CP

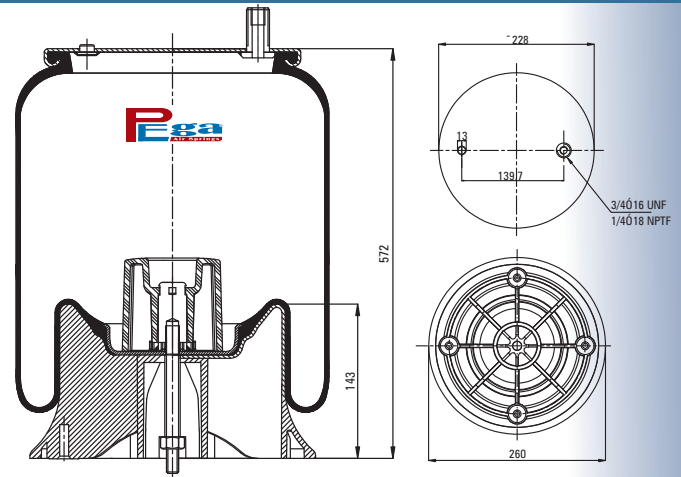

Cross References		OE Part No	
CONTITECH	9 10-17.5 P 548	SAF HOLLAND	90557157
FIRESTONE	1T15M-7.5	SAF HOLLAND	90557301
	W01 358 9935		
GOODYEAR	1R12-532		

PLASTIC PISTON

6 KG.

P10.9936.CP

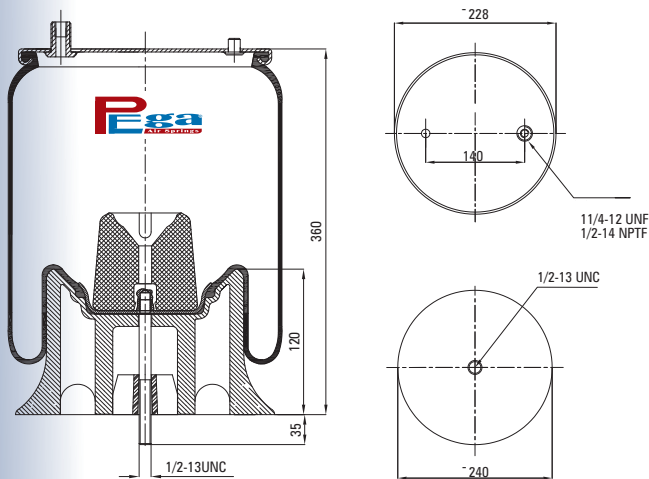

Cross References		OE Part No	
CONTITECH	9 10-17.5 P 454	SAF HOLLAND	90557156
FIRESTONE	1T15M-7.5	SAF HOLLAND	90557300
	W01 358 9936		
GOODYEAR	1R12-499		

PLASTIC PISTON

5,9 KG.

P10.9947.CP

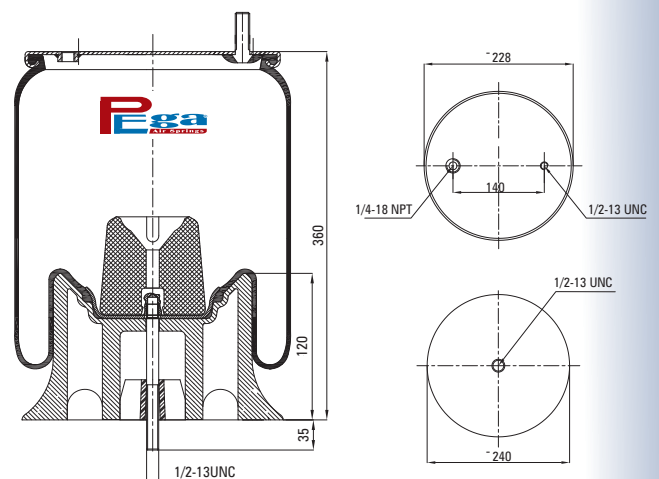

Cross References		OE Part No	
CONTITECH	9 10-17.5 P 452	REYCO	20142-01
FIRESTONE	1T15M-7.5	REYCO	20142-01K
	W01 358 9947		

PLASTIC PISTON

6,4 KG.

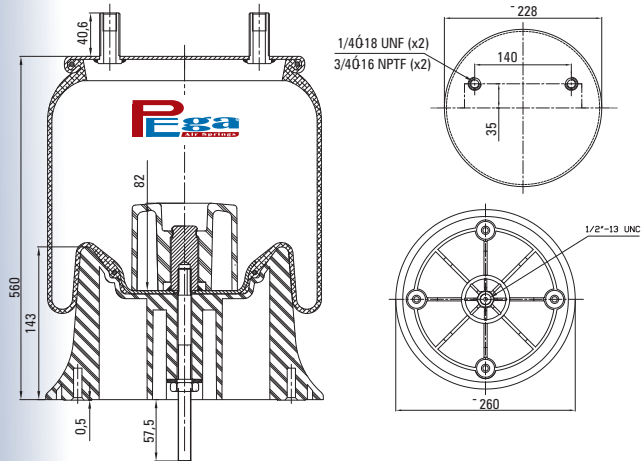

Cross References		OE Part No	
CONTITECH	9 10-17.5 A 930	SAF HOLLAND	90557332
FIRESTONE	1T15M-7.5		
	W01 358 9974		

PLASTIC PISTON

6,6 KG.

Notes