

Product Range

Edition 2015





*Quality is never accident;
it is always the result of intelligent effort.*
John Ruskin

All Original Equipment Manufacturer part numbers and Cross reference code numbers at the PEGA catalogue are itemized just for comparing.

It is not implied that any part listed is the product of these manufacturer.

We do not guarantee the accuracy or reliability and accept no liability for any loss or damage arising from any inaccuracies or omission in this catalogue

The contents of this catalogue must not be copied or reproduced without the written permission from PEGA Otomotiv Süspansiyon San. ve Tic. A.Ş.

©2015 by PEGA Otomotiv Süspansiyon San. ve Tic. A.Ş. All Rights Reserved.

Tüm OEM parça numaraları ve Çaprazlama İletişimindeki ürün kodları PEGA ürün kataloğunda sadece karşılaştırma amacı ile yer almaktadır.

PEGA Kataloğunda belirtilen ürün o üreticinin ürünü olduğuna dair bir bilgi yer almamaktadır.

Katalogda yer alan bilgilerin kesinliğine dair bir garanti vermiyoruz ve belirtilen ürün kriterlerinden ya da teknik bilgilerden kaynaklanan hata ya da zararlardan dolayı sorumluluk kabul etmiyoruz.

Bu katalogta yer alan bilgi ve resimler PEGA Otomotiv Süspansiyon San. ve Tic. A.Ş.'nin yazılı izni olmadan çoğaltılamaz ve farklı amaçlar için kullanılamaz.

©2015 PEGA Otomotiv Süspansiyon San. ve Tic. A.Ş. Tüm Hakları Saklıdır

EXPERIENCE AND POWER AT YOUR SIDE

PEGA OTOMOTIV SUSPANSIYON SAN.VE TIC.A.S. was established in 2008 by a team well experienced on developing, manufacturing and marketing air suspension systems on the International market for years. The built up knowledge attained by multinational companies and the high quality products have brought PEGA's name up to its righteous place on the World market.

Pega, as a major air spring manufacturer, is competing with the sector leaders in 75 countries all over the World with a high quality products and a range of over 900 types. Our main strength is our target to gain a maximum customers' satisfaction by providing constant improvement, high quality products and reliable services, which is a sine qua non "a must " of our market. PEGA OTOMOTIV SUSPANSIYON SAN.VE TIC.A.S. is certificated according to ISO TS 16949:2009 and ISO 14001:2004 standards to prove its quality and willingness to strengthen its continuous improvement.

Warranty Information

Pega® air springs that use in Buses, Trucks or Trailers have Standard two-year limited warranty featuring no mi/km restriction against failure due to material or workmanship defects.

WARRANTY HAVE SOME EXCLUSIONS:

- If an external solid matter caused a defect to the air spring.
- Operation of the air springs without air pressure or under the min. riding height.
- Over extension.
- Overloading the vehicle.
- Misalignment.
- Wrong installation.
- Using air spring in incorrect place.

TWO YEAR WARRANTY

Pega® air springs have been designed to provide thousands of miles or kms of trouble free service. The durability of Pega® Air spring is such that they will often outlast other maintenance items; such as shocks, bushings and levelling valves or other concerned parts related to the suspension system of vehicle. Pega® air springs are warranted to be free of material defects and/or workmanship for 2 years, depending upon the application. Free replacements may be provided by the manufacturer, dealer or by any Pega® air spring distributor (for details, please contact with customer representative). Since each individual air spring is closely examined and pressure tested at our production plant in Bursa, TURKEY. The vast majority of premature failures and consequent warranty returns are found not to be defected, but fail because of abuse caused by other problems associated with the suspension. Before you install a new air spring, you should carefully examine to determine what caused it to fail. If there was any problem in the suspension system, then the new air spring will also fail unless you correct the problem.



IMPORTANT DETAILS

• WARNING!

Do not inflate unless fully secured in the suspension or other adequate structure at design height. Improper use or over inflation may cause assembly to burst causing property damage and/or injury could result.

Working temperature -40°C to +70°C, -40°F to +158°F

• STORAGE

Air springs should be kept in a dark and dry storage area at normal room temperature.

• CHEMICAL RESISTANCE

Air Springs are;

Suitable for operation temperature from -40°C to +70°C, -40°F to +158°F

Resistant to oil contaminated compressed air

Resistant to chemical non-aggressive dust

Resistant to alkaline and acidic cleaning agent

Resistant to ozone

• AIR SPRINGS ARE NOT RESISTANT TO:

Solvents

Hydraulic oils

Lubrication grease

The components of PEGA airsprings



- 1- Mounting stud
- 2- Combo stud
Combination mounting stud and air fitting.
- 3- Plate
- 4- Outer rubber
- 5- Cord fabric
- 6- Inner rubber
- 7- Internal bumper
(Optional)
- 8- Piston
(Available in aluminium, steel or fibre-reinforced plastic)
- 9- Piston bolt
- 10- Bead ring
- 11- Blind nut
- 12- Air fitting hole
- 13- Girdle hub
- 14- Clamp plate
- 15- Clamp ring
- 16- Shock absorber
- 17- Air fitting
- 18- Ring mounting
(Built-in)
- 19- Ring mounting
(Replaceable bushings)
- 20- Metal rod

Complete rolling lobe

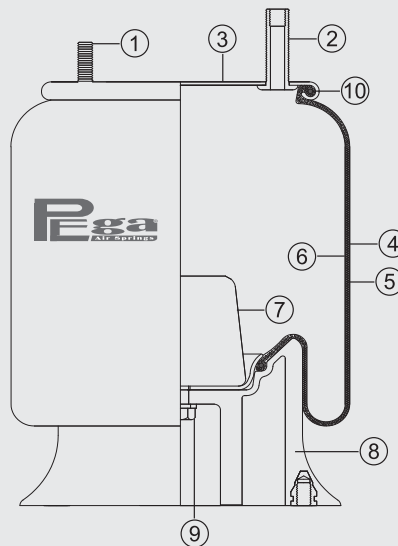

Cabin Airspring w/shock absorber

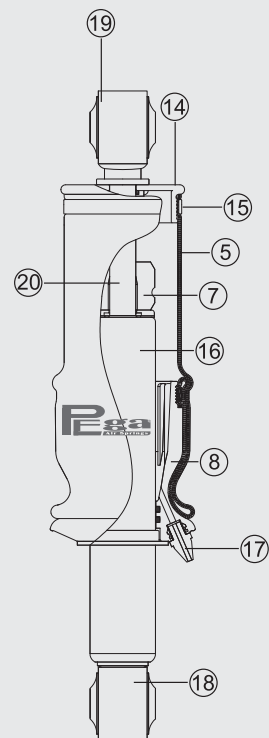

Convuluted bellow

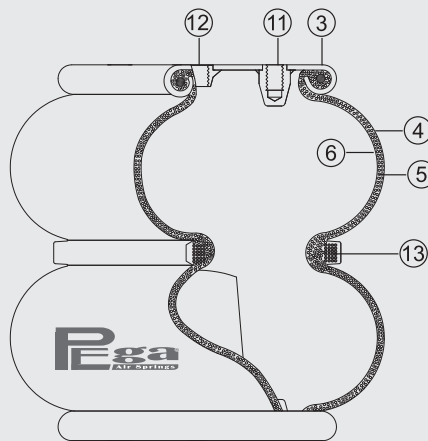

Sleeve type rolling lobe

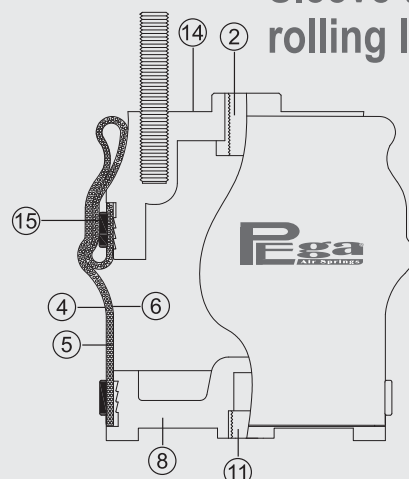

“Service Assembly”

A “Service assembly” includes a plate, bellows, internal bumper (if any), and all attaching hardware

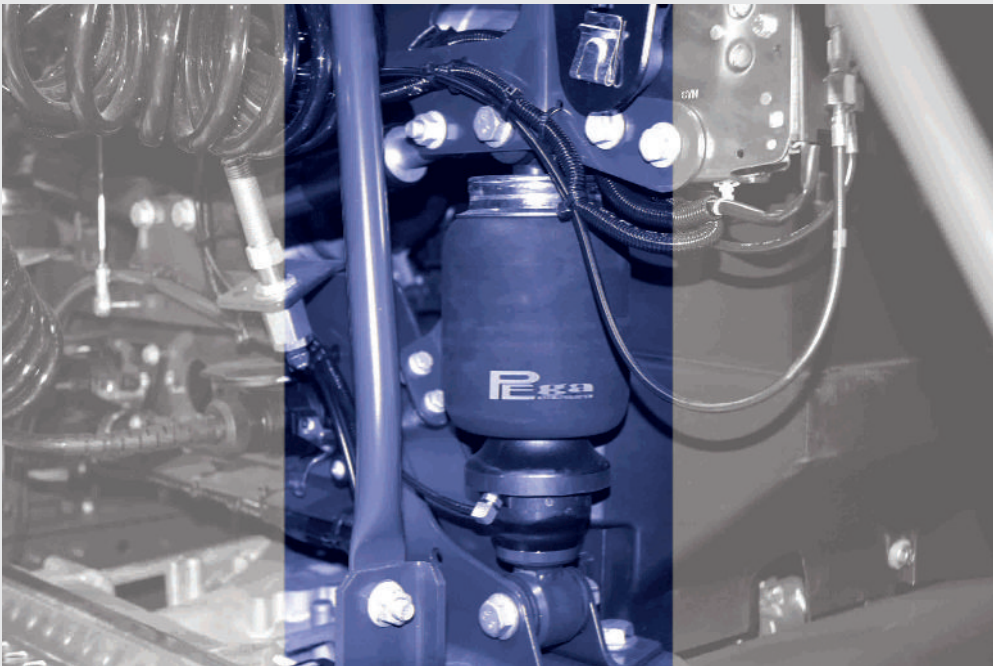

*You cannot hide comfort in
a cabin with PEGA cabin airsprings.*

P20.10101

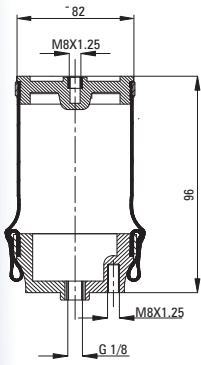

Cross References

CONTITECH SZ 51-5

OE Part No

SEAT

0,37 KG.

P20.10102

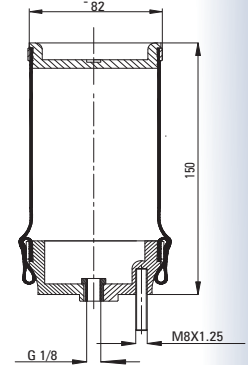

Cross References

CONTITECH SZ 51-10

OE Part No

SEAT

0,4 KG

P20.10103

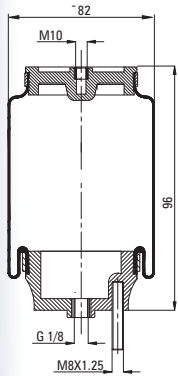

Cross References

CONTITECH SZ 51-7

OE Part No

SEAT

0,4 KG.

P20.10105

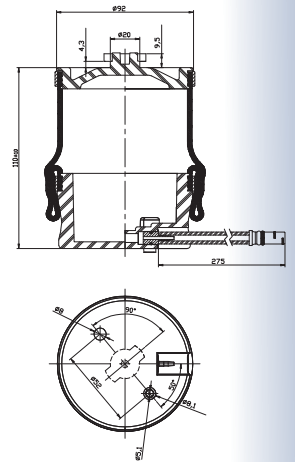

Cross References

CONTITECH SZ 82-8 LS

OE Part No

ISRINGHAUSEN 27403-01

0,5 KG.

P20.1101.B

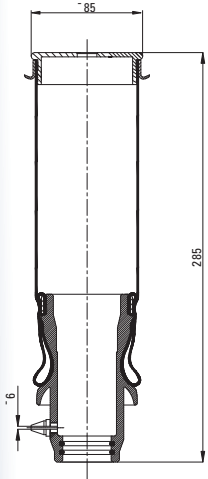

Cross References

SACHS	481002
MONROE	CB0066

OE Part No

SCANIA
93- 113- 143- T 113- T 143
1348121

FRONT - REAR

1 KG.

P20.1101.BA

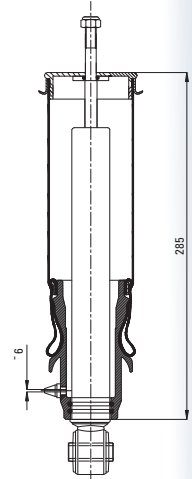

Cross References

SACHS	112320
SACHS	105845
SACHS	105831
SACHS	105876
SACHS	105875
MONROE	CB0065
MONROE	CB0066

OE Part No

SCANIA
93-113-143-T113-T143
1331621-1331635
393257-393208-393290
1117320-1117334
1331634-370227-370228
1331620-1116535-1348118
1348119-1348121-1348120
1348121-1348477-1348121
550365-1348117-1117326
1531200011-1331626

FRONT - REAR

2,4 KG.

P20.1201.B

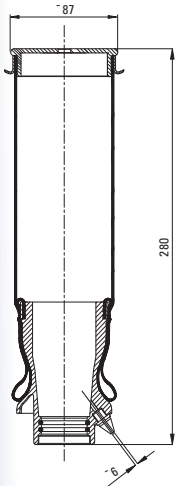

Cross References

MONROE	717262725
MONROE	CB0030

OE Part No

SCANIA
P & R SERIE, 4 SERIE
1381919
1476415

FRONT - REAR

1 KG.

P20.1201.FA

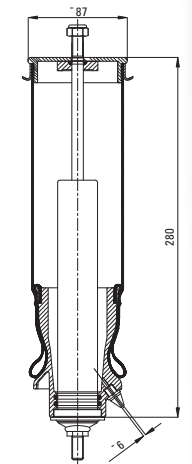

Cross References

MONROE	CB0010 + CB0030
--------	-----------------

OE Part No

SCANIA
P & R SERIE, 4 SERIE
1381903
1381904 / 1381919
1381904 / 1476415
1397395
1397399
1397400 / 1381919
1397400 / 1476415
1435859 / 1381919
1485852

FRONT

2,2 KG.

P20.1201.RA

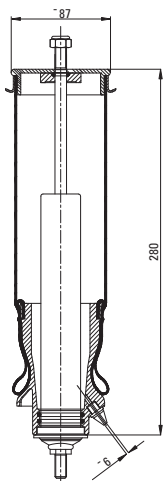

Cross References

MONROE CB0009 + CB0030

OE Part No

SCANIA
P & R SERIE, 4 SERIE
1381905
1381906 / 1381919
1381906 / 1476415
1397393 / 1397397
1397398 / 1381919
1397398 / 1476415
1435853
1435856 / 1381919
1435856 / 1476415

REAR

2,2 KG.

P20.1202.B

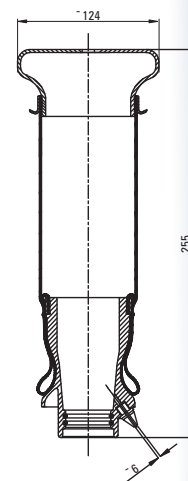

Cross References

SACHS 557001
MONROE CB0067

OE Part No

SCANIA
4 SERIE
94-114-124-144-164
1349840

FRONT - REAR

1,3 KG.

P20.1202.FA

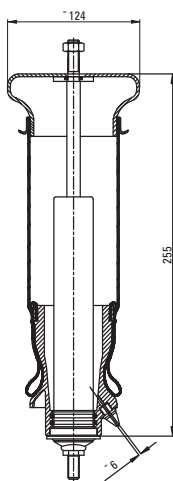

Cross References

SACHS 105871
SACHS 105872
SACHS 290201
SACHS 290203
SACHS 290988
SACHS 290987
MONROE CB0067 + CB0058

OE Part No

SCANIA
4 SERIE
94-114-124-144-164
1363122
1424228
1424227
1397396
1397400
1435859
1363120

FRONT

2,5 KG.

P20.1202.RA

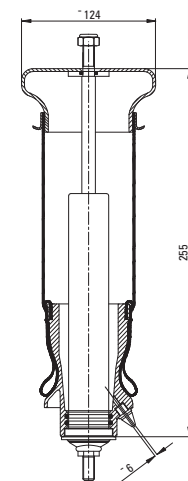

Cross References

SACHS 105873
SACHS 290989
MONROE CB0067 + CB0059

OE Part No

SCANIA
4 SERIE
94-114-124-144-164
1349844
1382826
1382827
1382829
1424229

REAR

2,5 KG.

P20.1301.B

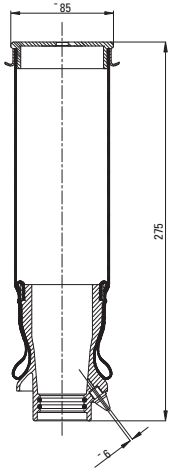

Cross References

SACHS 310619
MONROE CB0067

OE Part No

SCANIA
R SERIE
1424231

FRONT - REAR

1 KG.

P20.1301.BA

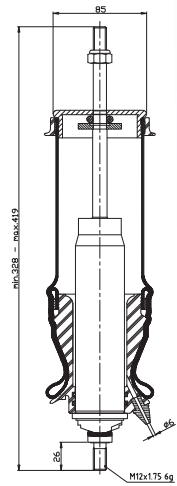

Cross References

OE Part No

FRONT - REAR

2,2 KG.

P20.1301.RA

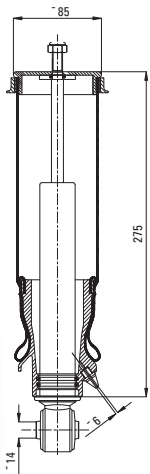

Cross References

MONROE CB0067 + CB0134
SACHS 310620

OE Part No

SCANIA
R SERIE
1502473
1505563

REAR

2,2 KG.

P20.1302.R

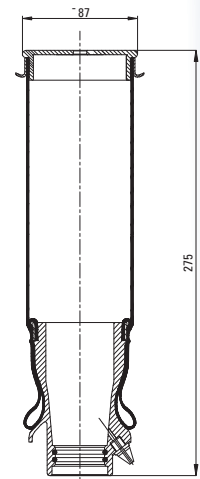

Cross References

MONROE CB0074

OE Part No

SCANIA
R SERIE
1502471
1502468

REAR

1 KG.

P20.1302.RA

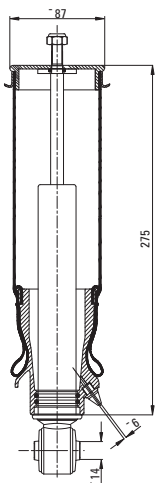

Cross References

MONROE CB0074 + CB0078

OE Part No

SCANIA
R SERIE
1502470
1502471
1502474

REAR

2,4 KG.

P20.1304.B

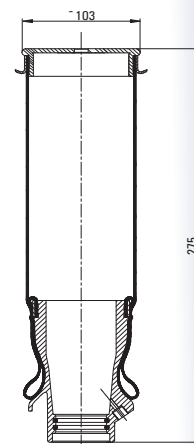

Cross References

SACHS 312465
MONROE CB0130

OE Part No

SCANIA
R SERIE
1444016

REAR

1,2 KG.

P20.1304.FA

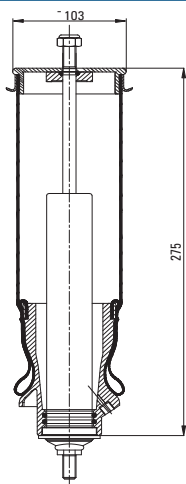

Cross References

SACHS 312465
SACHS 290987
MONROE CB0058 + CB0130

OE Part No

SCANIA
R SERIE
1363120
1397396
1397390
1397392

FRONT

2,1 KG.

P20.1304.RA

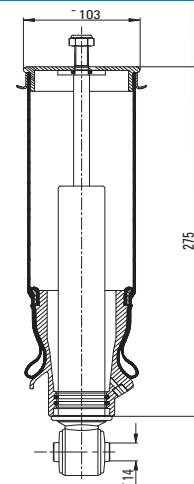

Cross References

SACHS 312465
SACHS 310620
MONROE CB0130 + CB0134

OE Part No

SCANIA
R SERIE
1505563

REAR

2,2 KG.

P20.20102

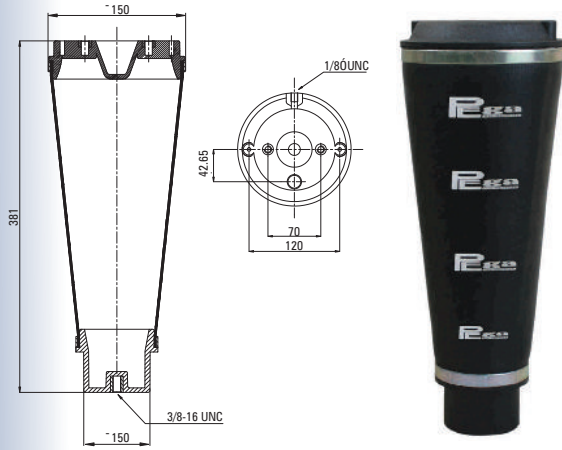

Cross References	
FIRESTONE	W21-760-9931

OE Part No

2,5 KG.

P20.20103

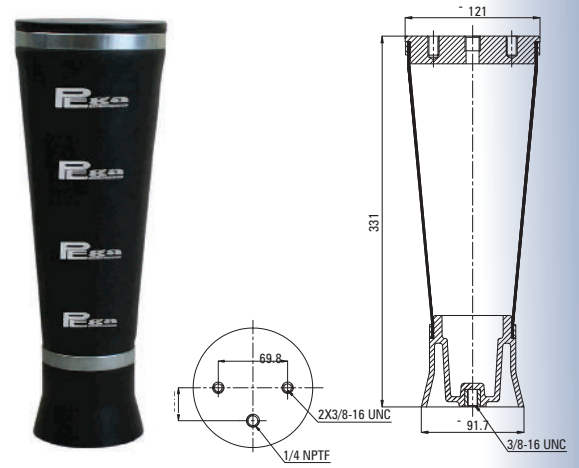

Cross References	
FIRESTONE	W21-760-9039

OE Part No

2,5 KG.

P20.2101.F

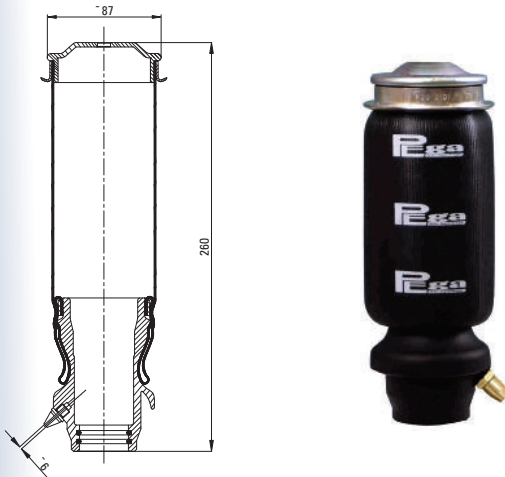

Cross References	

OE Part No
MERCEDES ACTROS

FRONT

1 KG.

P20.2101.FA

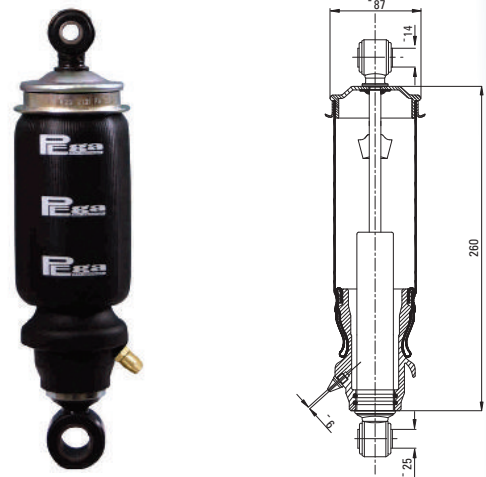

Cross References	
SACHS	105 392
MONROE	CB0089

OE Part No
MERCEDES ACTROS 942 890 0119 942 890 2919 A942 890 2919

FRONT

2,5 KG.

P20.2101.R

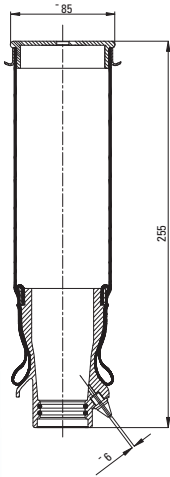

Cross References

OE Part No

MERCEDES
ACTROS

REAR

1 KG.

P20.2101.RA

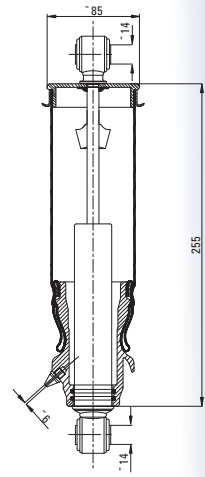

Cross References

OE Part No

SACHS OLD 290 997
SACHS NEW 311 189
MONROE CB0090

MERCEDES
ACTROS
942 890 02 19
942 890 60 19
943 890 39 19
A942 890 02 19

REAR

2,4 KG.

P20.2102.B

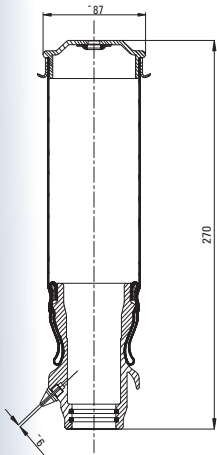

Cross References

OE Part No

MERCEDES

FRONT-REAR

1 KG.

P20.2102.FA

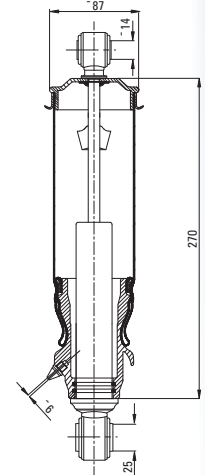

Cross References

OE Part No

SACHS OLD 290 998
SACHS NEW 311 663
MONROE CB0115

MERCEDES
943 890 38 19
942 890 59 19
942 890 53 19
A942 890 53 19
A942 890 59 19

FRONT

2,6 KG.

P20.2102.RA

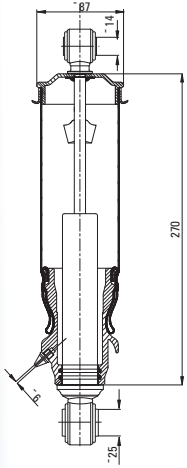

Cross References

OE Part No

REAR

kg 2,6 KG.

P20.2103.FA

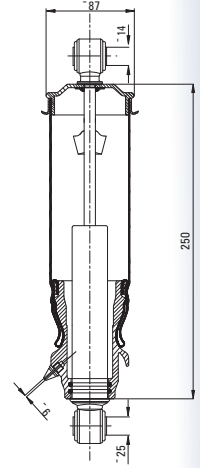

Cross References

OE Part No

SACHS NEW 105 408
MONROE CB 0108

MERCEDES
942 890 52 19
942 890 70 19

FRONT

kg 2,6 KG.

P20.2301.F

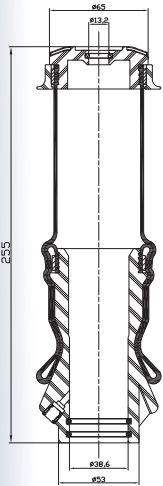

Cross References

OE Part No

FRONT

kg 1 KG.

P20.2301.FA

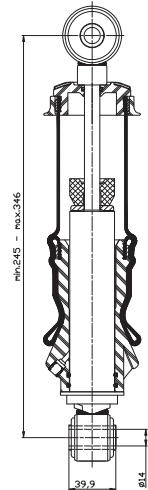

Cross References

OE Part No

SACHS 315153

MERCEDES
A942 890 49 19

FRONT

kg 1,8 KG.

P20.2301.R

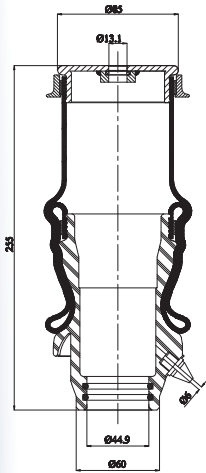

Cross References

OE Part No

REAR

1 KG.

P20.2301.RA

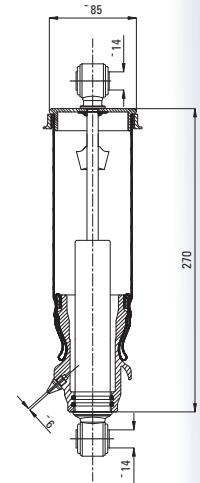

Cross References

OE Part No

SACHS 311 664
SABO 895231

MERCEDES
942 890 61 19

REAR

2,7 KG.

P20.30101.B

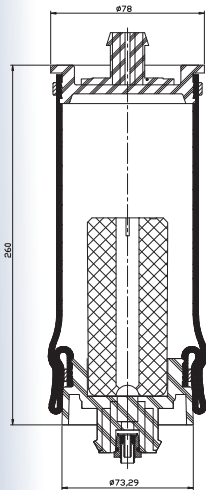

Cross References

OE Part No

FIRESTONE W02 358 7207

FREIGHTLINER
18-40977-000

0,7 KG.

P20.30102.B

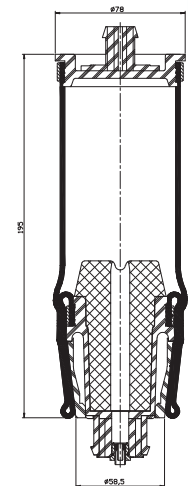

Cross References

OE Part No

FIRESTONE W02 358 7093

PETERBILT
29-06016

0,7 KG.

P20.30102.B1

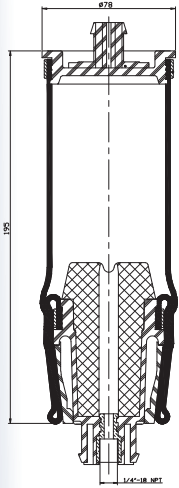

Cross References

OE Part No

kg 0,7 KG.

P20.3101.F

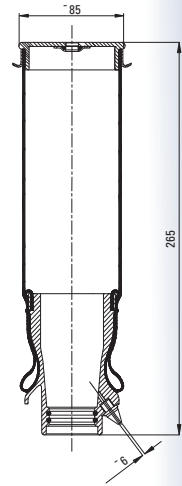

Cross References

OE Part No

MAN
F2000

FRONT

kg 1 KG.

P20.3101.FA

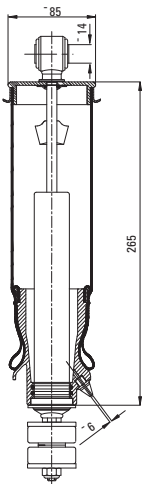

Cross References

OE Part No

SACHS 105855
MONROE CB 0092

MAN
F2000
81 41722 6048
81 41722 6051

FRONT

kg 2,6 KG.

P20.3101.R

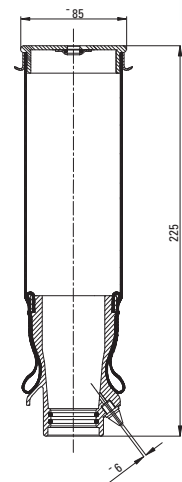

Cross References

OE Part No

MAN
F2000

REAR

kg 1 KG.

P20.3101.RA

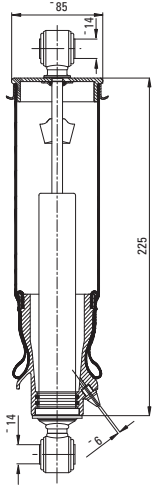

Cross References	
SACHS	105856
MONROE	CB 0091

OE Part No
MAN
F2000
TGA
81 41722 6052
81 41722 6049

REAR

2,3 KG.

P20.3102.FA

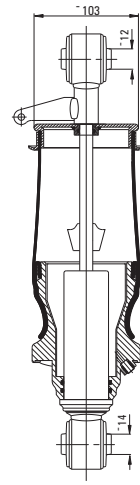

Cross References	
SACHS	135174
SACHS	135196
SACHS	313 181

OE Part No
MAN
TGA
85 41722 6008
81 41722 6077
85 41722 6014
85 41722 6022

FRONT

3 KG.

P20.3103.FA

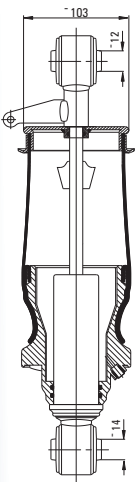

Cross References	
SACHS	135195
SACHS	135197
SACHS	313 182

OE Part No
MAN
TGA
85 41722 6009
85 41722 6078
85 41722 6015
85 41722 6023

FRONT

3 KG.

P20.3104.RA

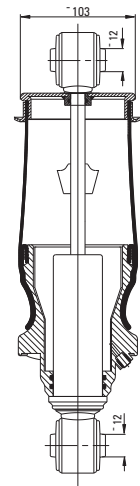

Cross References	
SACHS	135198
SACHS	105378
SACHS	313 183
WABCO	964 006 0050

OE Part No
MAN
TGA
81 41722 6057
81 41722 6075
85 41722 6006
85 41722 6012

REAR

2,83 KG.

P20.3105.RA

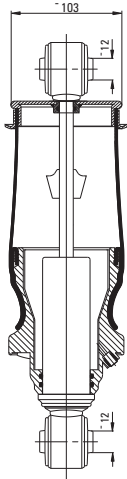

Cross References

SACHS	135200
SACHS	135199
SACHS	313 184

OE Part No

MAN
TGA
81 41722 6058
85 41722 6007
85 41722 6013
85 41722 6024
81 41722 6078
81 41722 6076

REAR

2,8 KG.

P20.34006

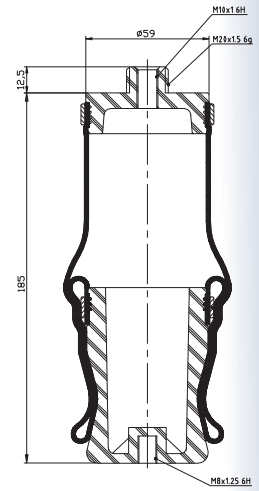

Cross References

OE Part No

KAMAZ

0,3 KG.

P20.35101

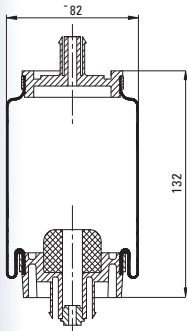

Cross References

FIRESTONE	W02 358 7206
CONTITECH	AB SZ70

OE Part No

FREIGHTLINER
18-29919-000

0,7 KG.

P20.39000.SL



Cross References

OE Part No

2,5 KG



P20.39001.SL

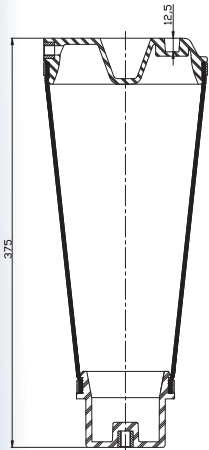

Cross References

OE Part No

kg 2,5 KG

P20.4101.FA

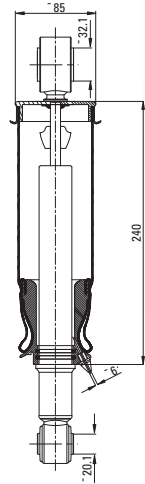

Cross References

OE Part No

SACHS 310 820
MONROE CB 0137

IVECO
STRALIS
500 357 351
500 340 705

FRONT

kg 3,2 KG.

P20.4101.RA

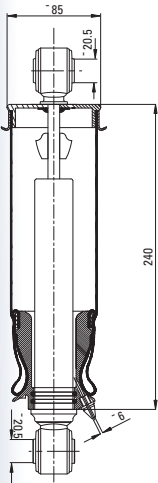

Cross References

OE Part No

SACHS 310 821

IVECO
STRALIS
500 357 352

REAR

kg 2,5 KG

P20.4102.RA

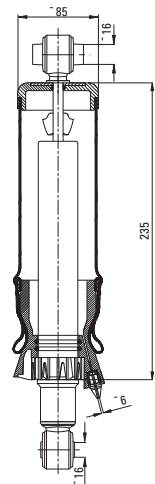

Cross References

OE Part No

SACHS 731 700000277
SACHS 73 1700 002 845
SACHS 311 884
MONROE CB 0149

IVECO
STRALIS
504 060 241
504 060 233

REAR

kg 3,2 KG.

P20.4103.FA

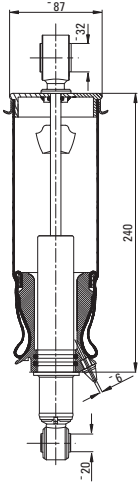

Cross References

ARVINMERITOR 908322985
MONROE CB 0137

OE Part No

IVECO
STRALIS
500 340 705
500 357 351

FRONT

3,5 KG.

P20.4103.RA

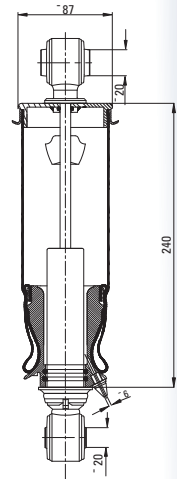

Cross References

ARVINMERITOR 908322986
MONROE CB 0136

OE Part No

IVECO
STRALIS
500 340 706
500 357 352

REAR

2,8 KG.

P20.4104.RA

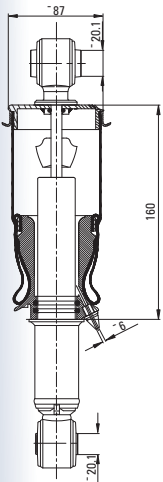

Cross References

ARVINMERITOR 908323140

OE Part No

IVECO
STRALIS
504 060 233

REAR

3 KG.

P20.4201.RA

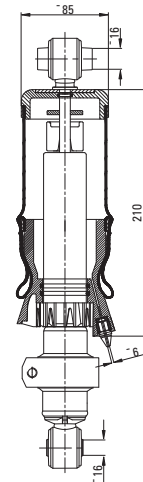

Cross References

SACHS 115 743

OE Part No

IVECO
EUROTECH-EUROSTAR
4102 8764
4102 8763
500377878
500348793

REAR

3,2 KG.

P20.4202.RA

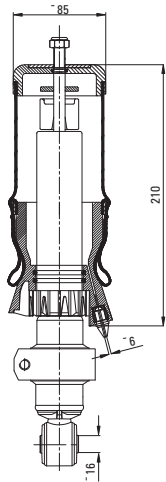

Cross References

SACHS	115731
MONROE	CB 0098

OE Part No

IVECO
EUROTECH-EUROSTAR
500379698
500307338
9945 5937
500352808
9943 8514
9847 2734

REAR

3 KG.

P20.4203.F

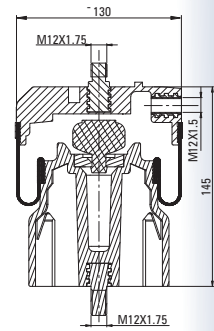

Cross References

PIRELLI	IGC130-30
MONROE	CB 0077

OE Part No

IVECO
EUROTECH-EUROSTAR
41015530
41019150
8169050

FRONT

1,5 KG.

P20.5101.B

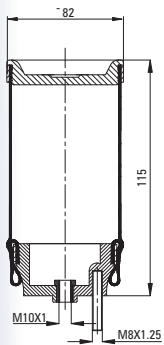

Cross References

CONTITECH	SZ50-10
MONROE	CB0083

OE Part No

RENAULT
G 340 TI
5010266845A
5010 313 619 A

FRONT

0,5 KG.

P20.5102.B

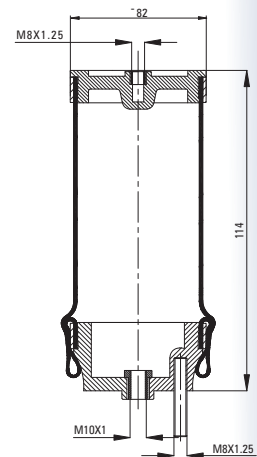

Cross References

CONTITECH	SZ50-8
MONROE	CB0082

OE Part No

RENAULT
G 340 TI
5010 092 916 E

REAR

0,4 KG.

P20.5103.B

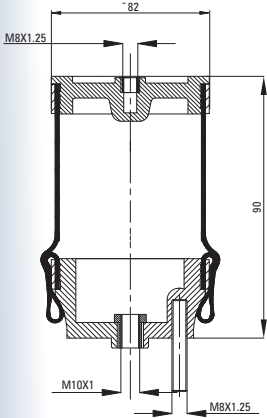

Cross References	
CONTITECH	SZ50-6

OE Part No
RENAULT GAMME G 5010 133 079 D

FRONT

0,4 KG.

P20.5201.B

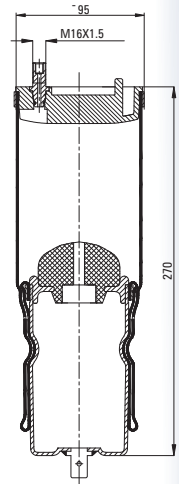

Cross References	
CONTITECH	816-Z
MONROE	CB0076

OE Part No
RENAULT MAGNUM 5010 320 096A

FRONT - REAR

2 KG.

P20.5203.RA

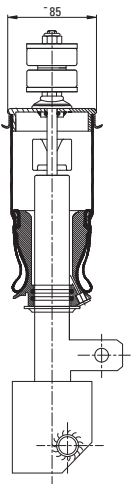

Cross References	
MONROE	CB 0070

OE Part No
RENAULT MAGNUM E-TECH 5010 228 849

REAR

3,9 KG.

P20.5204.RA

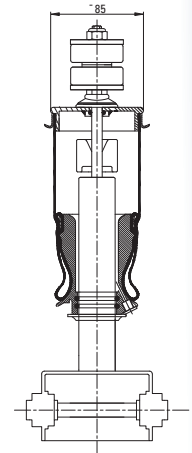

Cross References	
MONROE	CB 0118

OE Part No
RENAULT MAGNUM 2089 8055 5010 629 471 742 089 8055 748 205 2893 820 528 93

REAR

4,5 KG.

P20.5301.RA

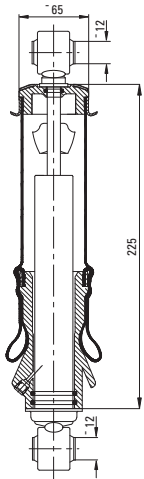

Cross References

CONTITECH	SZ36-10
SACHS	131041
SACHS	310957
MONROE	CB 0088

OE Part No

RENAULT
PREMIUM
5010 228 908
5010 316 783
5010 269 674
5010 269 674

REAR

1,8 KG.

P20.5302.F

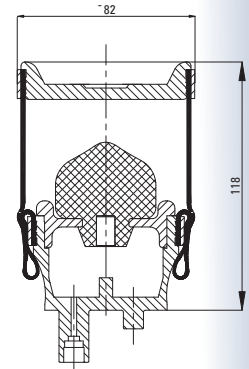

Cross References

CONTITECH	SZ50-9
MONROE	CB 0075

OE Part No

RENAULT
PREMIUM
5010 130 797 G

FRONT

0,5 KG.

P20.5302.F1

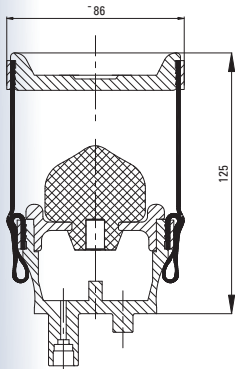

Cross References

CONTITECH	SZ50-9 PO2
MONROE	CB 0075

OE Part No

RENAULT
PREMIUM
5010 629 414

FRONT

0,5 KG.

P20.5303.R

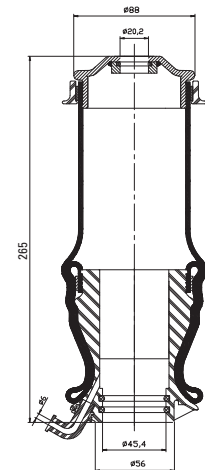

Cross References

OE Part No

REAR

1 KG.

P20.5303.RA

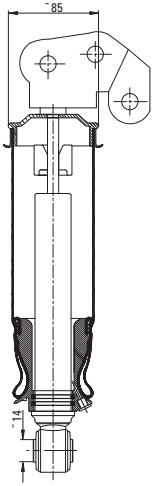

Cross References

SACHS	25376537
SACHS	78100001622
SACHS	313 072

OE Part No

RENAULT 440
PREMIUM
5010 615 879

REAR

3,3 KG.

P20.6101.F

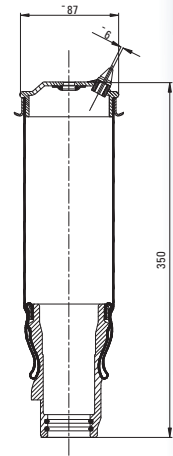

Cross References

OE Part No

VOLVO
FH12-FH16

FRONT

1,2 KG.

P20.6101.FA

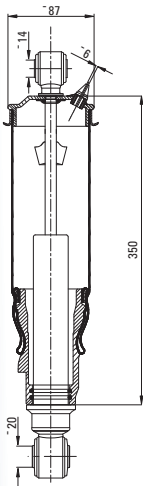

Cross References

MONROE	CB 0003
--------	---------

OE Part No

VOLVO
FH12-FH16
3172984
1629724
1629719

FRONT

2,8 KG.

P20.6102.R

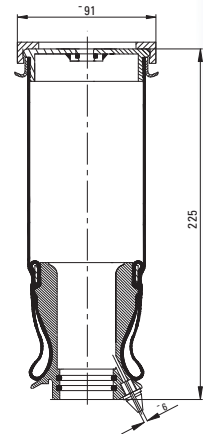

Cross References

OE Part No

VOLVO
FH12-FH16

REAR

1,2 KG.

P20.6102.RA

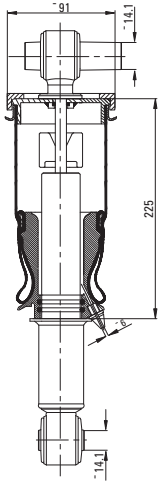

Cross References

MONROE CB 0006

OE Part No

VOLVO
FH12-FH16
20427897
20775212
20889134
20721169

REAR

3,3 KG.

P20.6103.R

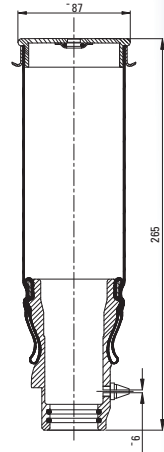

Cross References

CONTITECH 4757 N P21

OE Part No

VOLVO
FH12-FH16

REAR

1,3 KG.

P20.6103.RA

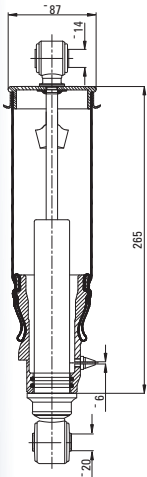

Cross References

MONROE CB 0002

OE Part No

VOLVO
FH12-FH16
1075076
1075077

REAR

2,8 KG.

P20.6104.F

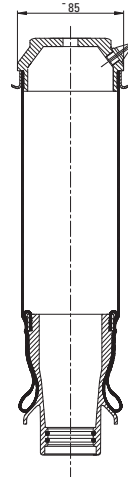

Cross References

MONROE CB0055

OE Part No

VOLVO
FH12

FRONT

1,2 KG.

P20.6104.FA

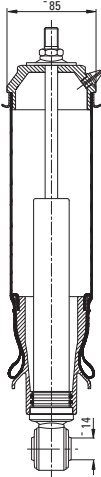

Cross References	
MONROE	CB0055
MONROE	CB0039

OE Part No
VOLVO
FH12
20453256
20889132
21111932
20889132-1

FRONT

2,8 KG.

P20.6105.FA

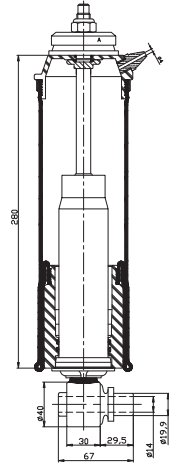

Cross References	
MONROE	CB 0102
MONROE	CB 0039

OE Part No
VOLVO
20453258
20889136
21111942
3198837

FRONT

2 KG.

P20.7101.FA

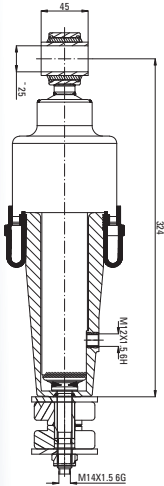

Cross References	
MONROE	CB 0033

OE Part No
DAF
95 - 95XF
126281
1285393
1321590
1353450
1353453
1371065
1444147
1622211
375224

FRONT

3,2 KG.

P20.7101.RA

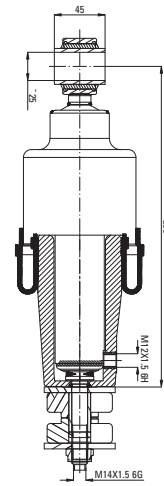

Cross References	
MONROE	CB 0034

OE Part No
DAF
95 - 95XF
1265282
1285394
1321591
1353451
1353454
1371066
299862
1623477

REAR

3,2 KG.